

Operation Instruction for –

Hercules Joystick series



Waist harness model

Table of Contents

Introduction3

Hercules Features3

Hercules Specifications4

How to Turn on Transmitter5

How to Turn off Transmitter5

How to Install Receiver5

User's Reminder7

Function Checking/Maintaining Steps8

Trouble Shooting8

Hercules Dimension Layout10

Hercules Wiring Diagram11

Limited One Year Warranty13

The FCC require the user to be notified that any changes or modifications made to this device that are not expressly approved by 3e may avoid the user's authority to operate the equipment.

To comply with FCC RF exposure requirement, this device and its antenna must no be co-located or operating in conjunction with any other antenna or transmitter.

Introduction

Suitable for multi applications, we made **Hercules** joystick type remote controller serves, it's proper purpose in every single place...

Hercules Joystick type remote controller could be used for almost all of the environments, design fit to ergonomic which could release the strain from neck after long time operation. We offered different models for selection to meet your need.

A suitable tool could always save your time, money and energy. **Hercules** took the latest technology with long-life, stable components, made operation simple and easy, shorten the shut down time to get more profit

Hercules Features

- Light weight, wireless transmitter took PC & PA casing material, enclosure up to IP65, strong shock proof, water / dust resistance, internal antenna design avoid possible damage, waist-belt could release pain through long time usage.
- Receiver casing enclosure up to IP67, dust / water / ultraviolet rays resisted, instant connector saves time in installation and repair easily; interruption free perfectly.
- European made industrial-used joystick, operation life reached million times, power-saved design as easily replace 6pcs of AA1.5V batteries once.
- Custom-made request accepted if standard models still could not reach your need.

System Features in 4R

- ◆ Raise the production efficiency, simple instructions to reduce time-waste, also could keep manufacture continuously.
- ◆ Reduce manpower – operator could hang up hook by own without extra help.
- ◆ Remove handling from dangerous environment as heat, strong acid, alkali...
- ◆ Replaced & upgraded cabin into motive function, prime cost for manufacture and maintenance saved.

Hercules – Your reliable tool, efficient partner in work side !!

Hercules specifications

RECEIVER

TRANSMITTER

Frequency range: 433MHz (20 channels)	Frequency range: 433MHz (20 channels)
Frequency control: Quartz crystals	Frequency control: Quartz crystals
Channel spacing : 60KHz	Channel spacing : 60KHz
Output power: less than 10mW	Output power: less than 10mW
Operation temperature: -10°C~ +70°C	Operation temperature: 0°C~ +70°C
Ratio output voltage: 0 ~ 10V (coordinate w/ inverter)	Antenna impedance: 50Ω
Ratio output current: 0 ~ 1A (coordinate w/ hydraulic valve)	Adjustment method: F1D
	Mix transmitting: > 60dBc
Security code: 256 sets	Security code: 256 sets
Responds time < 50mS	Responds time < 50mS
Enclosure level: IP67	Enclosure level: IP65
Contact capacity: 250V 10A	Contact capacity: 250V 10A
Operation voltage: - DC12V,24V (for mobile hydraulic crane used) - AC-110V / 220V / 380V ~415V, 50 / 60Hz (for crane used) - Adapter needs to be exchanged	Power Supply : - DC 9V Battery (1.5V AA x 6PS)
Weight: 1,430g – Box 2	Weight: 1480g
Dimension: 200mm L x 265mm W x 95mm H	Dimension: 230mm L x 153mm W x 185mm H

How To Turn On Transmitter

(1) Power on receiver.

(2) Push **any toggle switch** and release OR push **any axis-fingertip joystick** and release to operate

(3) And simply push R1 toggle switch to on & release

(4) Now **Hercules** is ready for operation.

How to Turn Off Transmitter

(1) Push-down EMS button, then pull out the power-on key.

The EMS stop button is with dual protections, every motion will be terminated in 0.1 sec.

(2) Always pull out power-on key after transmitter is no usage.

(3) shut down receiver.

How to install receiver

Tools:

long nose plier diagonal cutting plier cross head screwdriver
hexagonal head wrench multimeter electric drill cable and feeder

Steps:

- (a) Ensure the original wired-control operates normally
- (b) Switch off the main power of crane before installation
- (c) Receiver must be installed in a stable & easy-seen location
- (d) Installation location shall keep away from motor, relays, cables, large adapter, high voltage equipment or screen which may intermit the electric wave transmitting

- (e) Same channel remote controllers shall be installed at least 50M away, to avoid possible interruption
- (f) Ensure cabling is correct & stable
- (g) Test the transmitter after installation, ensure every motion is the same as the original wired control
- (h) Fix the original wired control panel in firmed place

Avoid receiver be installed inside the control panel or on the top

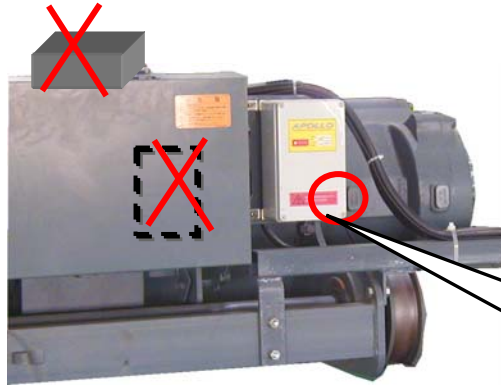

Using 4 screws with electric screw driver

dual-color LED shall be seen easily from ground

(fig.4) receiver installation



Warning :

- a. Every output contact current shall never over 5A.
- b. Re-power on receiver ONLY if cabling is correct and has been double-checked, or may cause unnecessary damage.

NOTE:

Install receiver on the top of control panel firmly, make receiver antenna point to top, so could receive clear signals from transmitter.

If using instant connector (optional) will save lots of time in installation, plug in the cable & lock with springs, push out springs to take connector out.

Hercules receiver contains perfect design for security / safety purpose, receiver may stop automatically when interference occurred.

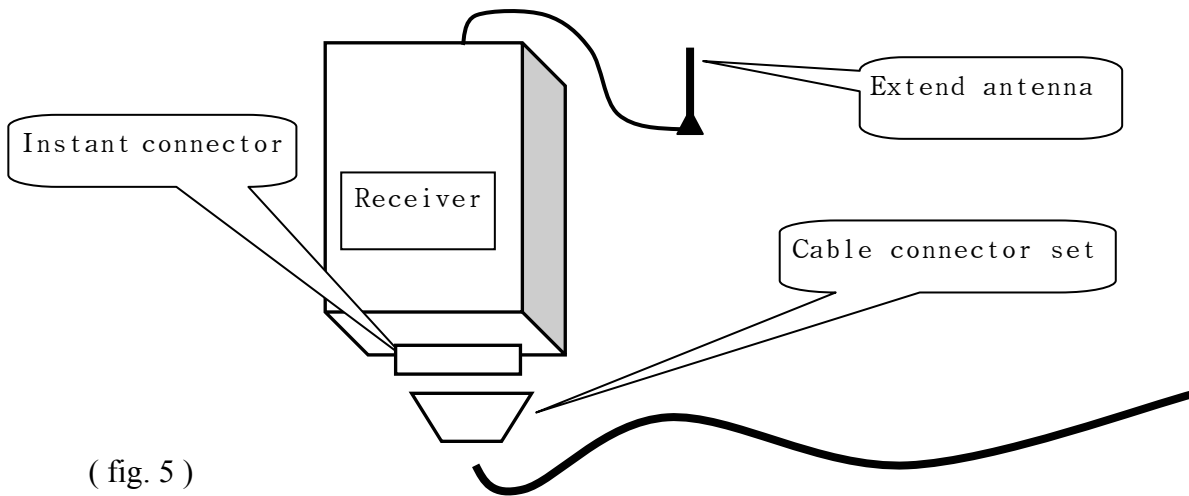

(fig. 5)

User's Reminder

Study this Operation Instruction carefully before usage, ensure every single step is clear. **Hercules** remote controller could only be operated after complete training and authorized.

If damaged occurred, shut down **Hercules** and call your agent, **never try to repair by your own to avoid unnecessary danger.**

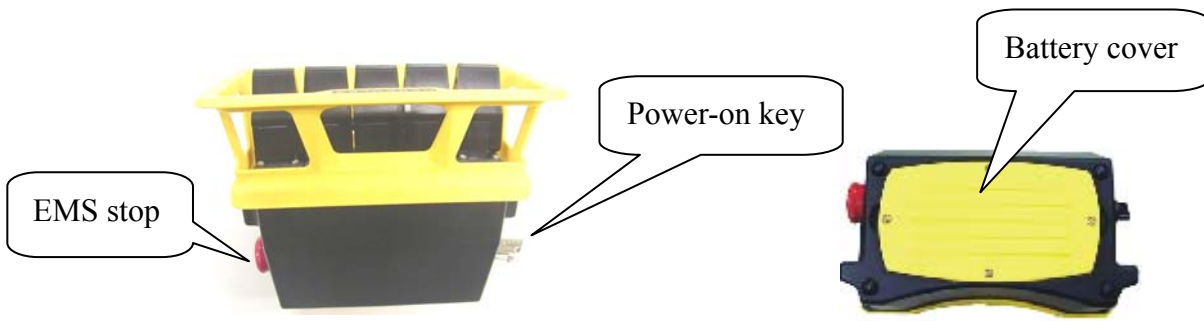

(fig. 6) Hercules transmitter

(fig.7)

Ensure batteries have been set correctly before usage.

Using 6pcs of AA1.5V batteries for operation, up side down the transmitter, unscrew battery cover, insert batteries according to the pole, then the green indicator should be blinked regularly.

If indicator is in red blinked, it means battery low, please make the lifting goods move to the safe place first, push down the EMS stop or pull-out the key to shut down the device, then replace another 6ps of new batteries IMMEDIATELY. **Re-operate device with power-on steps.**

Function Checking/ Maintaining Steps

Takes 2 minutes to check / maintain device regularly will always extend **Hercules** operation period...

Hercules checking steps –

1. Keep safety distance between loading goods / crane and operators
2. Send power to receiver
3. Switch on transmitter by steps (please refer ' how to power on transmitter, p.6)
4. Push joysticks gently (from the slowest speed) , see if the control direction is correct

if yes means normal ...

Ensure the transmitter EMS button hasn't been stuck.

Ensure the joystick dust-shield isn't broken

Ensure transmitter waist-belt isn't broken (call your agent for these matters w/o hesitation)

if no means malfunction occurred...

1. Push down EMS button IMMEDIATELY and pull out POWER key.
2. Ensure the working hoist is stopped completely
3. Loading the goods to the safety place **FIRSTLY** with the original wired-control
4. Check the indicators from receiver panel

(fig. 8)

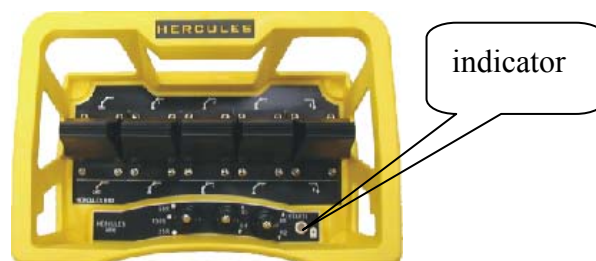

Trouble Shooting

TRANSMITTER...

1. Under stand-by status, the indicator is green and blinking 1 times per 2 sec.
2. Under operation , the indicator is green and blinking 2 times per 1 sec

3. If indicator turns to red...

it means power low, please replace batteries IMMEDIATELY.

RECEIVER...

1. If indicator is off...

Please check if no power supply or fuse is fused.

2. If indicator turns to red and blinking un-regularly...

It means an interruption occurred by unidentified signal, please contact with your supplier IMMEDIATELY.

3. If indicator turns to red and blinking un-regularly (blinking slowly, 1 times per sec.)...

It means CPU is stop working, please power off and re-power again.

4. If indicator turns to red and blinking un-regularly (blinking fast, 3 times per sec.)...

It means the address codes between transmitter and receiver switched different, please check the code on both transmitter and receiver to switch them to the same position.

Hercules Dimension Layout

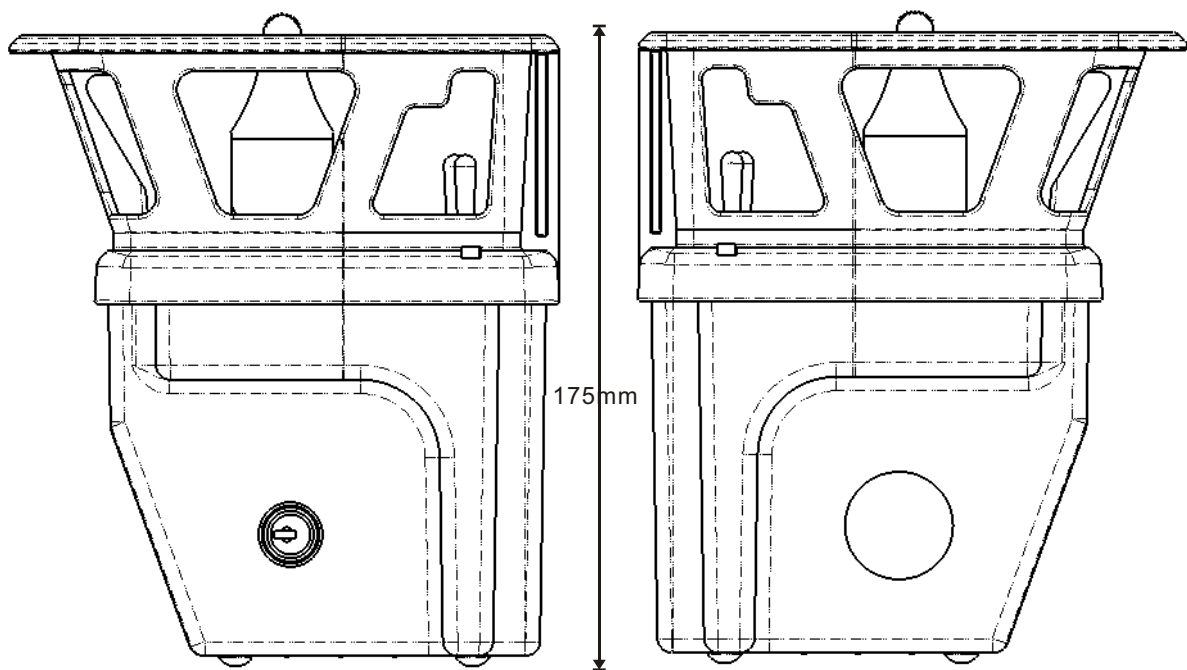
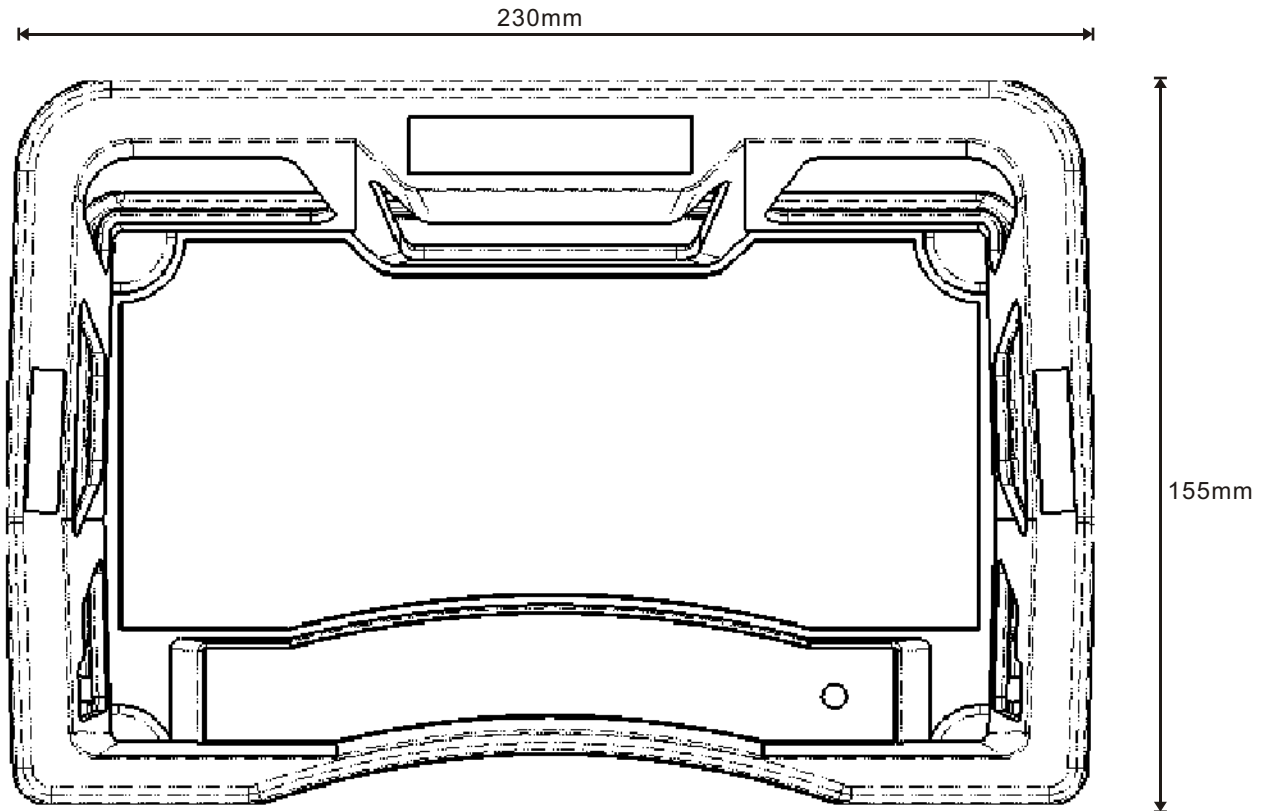

Hercules

Installation Wiring Diagram

by 3-Elite

HERCULES A5-PROP Installation Wiring Diagram

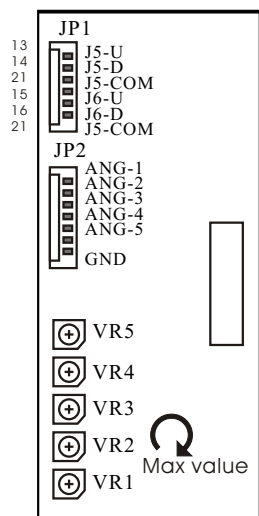

Inverter Proportional voltage output board

K1 CPU
K2 Main

F1 0.25A power fuse
F2 5A (Main)main fuse

R1/R2 on/off
R3/R4 on/off

VR1-6 adjust ANG1-6 voltage from 0~10V DC

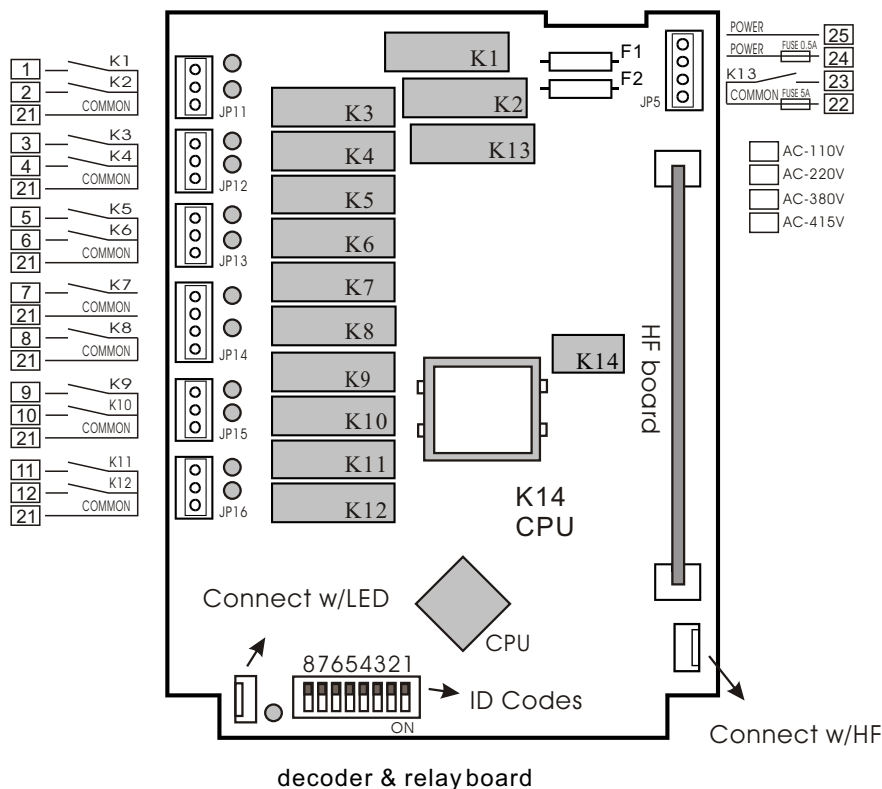

Control wiring diagram

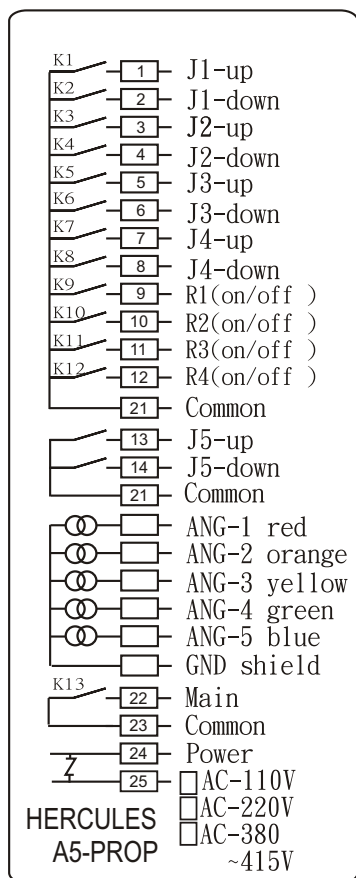

Transmitter layout

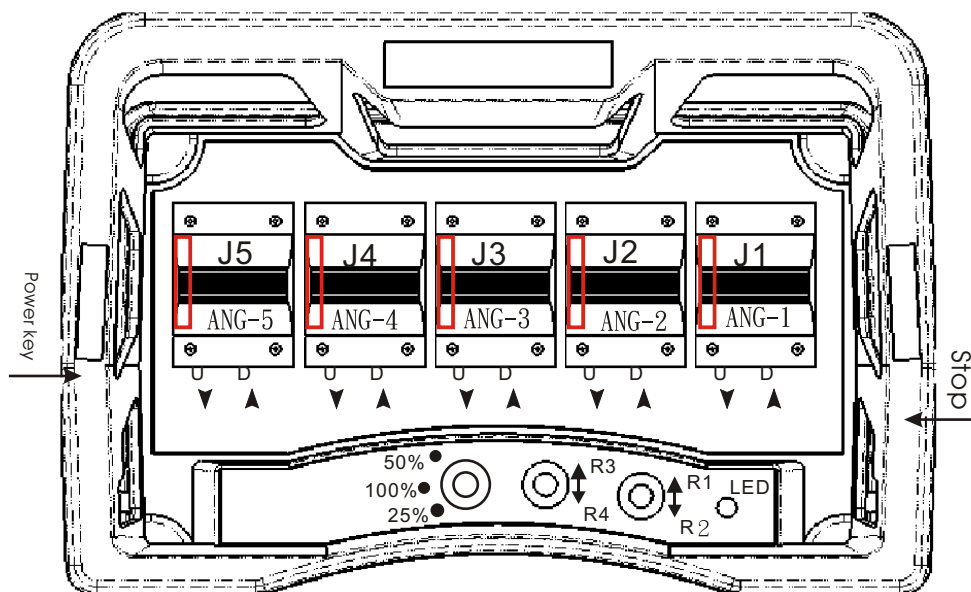

Batter: AA x 6ps (9V)

power indicator -operation: red light

-lower voltage: red light: please replace battery (better use alkaline battery)



Our duty is ensure your safety, so you can rely on an excellent device

Limited One Year Warranty

The equipment is warranted for one year from date of purchase against defects in materials or workmanship provided it was purchased from 3-Elite or authorized dealer.

This warranty does not cover equipment which has been abused or damaged by careless handling or shipping, OR damaged by nature disaster such as earthquake, typhoon ...etc.

The careless handling including self-change components, antenna, voltage; or circuits, and switches increased would be deemed as end of warranty, user should cover the repairing fee.

Should any defect develop, we will, at our option, repair or replace any defective parts without charge for either parts or labor. If we cannot correct the defect in your equipment, we will replace it at no charge with a new one. We will pay for the cost of returning your merchandise to you.

This warranty applies only to items returned to us, shipping costs prepaid, within one year from the date of purchase.