



OPERATION AND MAINTENANCE INSTRUCTIONS FOR
THE SCOTT PAK-ALERT SE[®] 7 DISTRESS ALARM
INCLUDING THE OPTIONAL SCOTT PAK-TRACKER LOCATOR SYSTEM
INTEGRATED WITH THE SCOTT AIR-PAK[®] 75 or NxG7
SELF-CONTAINED BREATHING APPARATUS (SCBA)

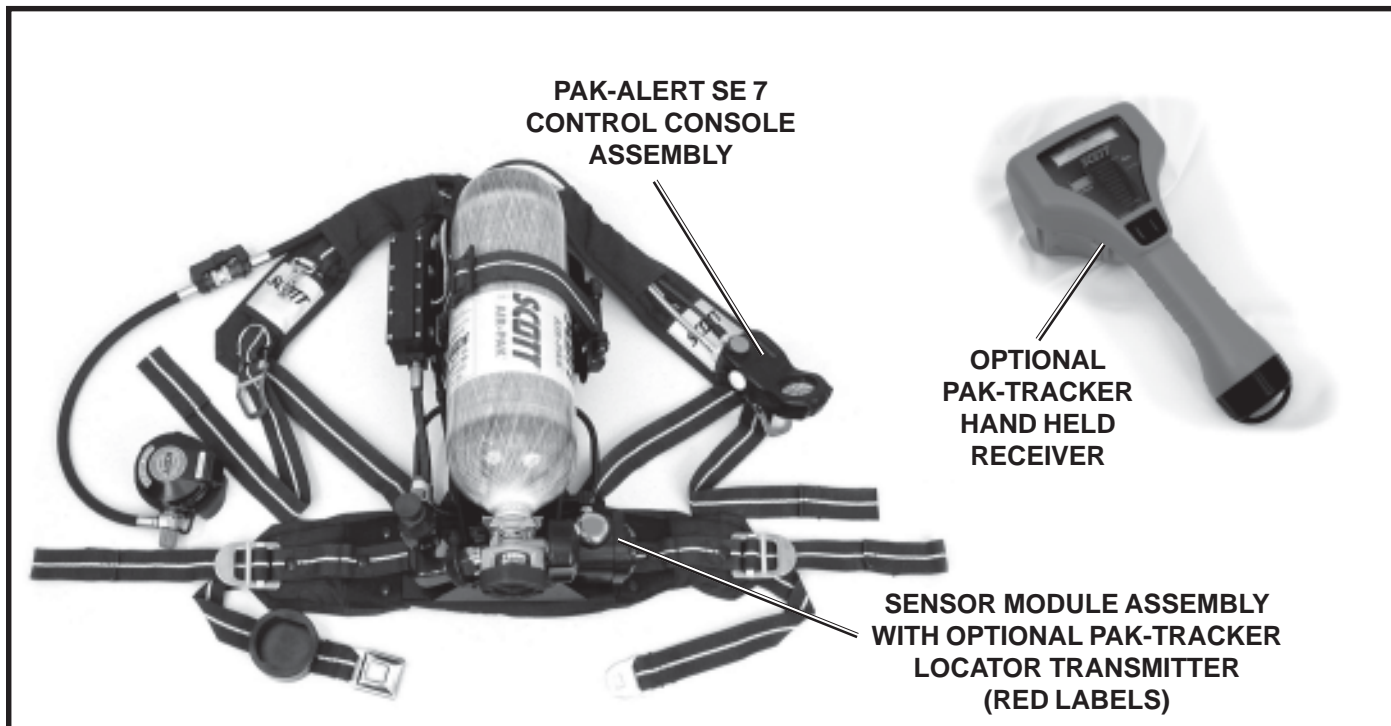

FIGURE 1
AIR-PAK SCBA WITH PAK-TRACKER LOCATOR TRANSMITTER
SPECIALLY EQUIPPED PAK-ALERT SE 7 DISTRESS ALARM ASSEMBLY

WARNING

THE SCOTT PAK-ALERT SE 7 DISTRESS ALARM WITH THE PAK-TRACKER LOCATOR SYSTEM IS INTENDED FOR USE WITH SCOTT SELF-CONTAINED BREATHING APPARATUS (SCBA) WHICH MAY SUPPORT HUMAN LIFE IN HAZARDOUS ATMOSPHERES. FAILURE TO CAREFULLY READ AND UNDERSTAND THE FOLLOWING INSTRUCTIONS MAY RESULT IN SERIOUS INJURY OR DEATH TO THE SCBA USER.

USE OF A RESPIRATOR EQUIPPED WITH A PAK-ALERT SE 7 DISTRESS ALARM WITH THE PAK-TRACKER LOCATOR SYSTEM WILL REQUIRE MODIFICATION OF THE RESPIRATOR "REGULAR OPERATIONAL INSPECTION PROCEDURES" AND WILL REQUIRE TRAINING OF THE RESPIRATOR USER IN THE USE OF PASS EQUIPPED RESPIRATORS.

THE FOLLOWING INSTRUCTIONS SUPPLEMENT BUT DO NOT REPLACE THE OPERATING AND MAINTENANCE INSTRUCTIONS SUPPLIED WITH EACH RESPIRATOR.

DESCRIPTION

The PAK-ALERT SE 7 distress alarm is a PERSONAL ALERT SAFETY SYSTEM (PASS) intended to assist in locating a respirator user who is incapacitated or in need of assistance. The SCOTT PAK-ALERT SE 7 distress alarm, P/N 200451-SERIES, is an optional accessory intended only for use on SCOTT SCBA respirators including the AIR-PAK® 75, Wireframe, and NxG7 Self-Contained Breathing Apparatus (SCBA). This line of electronic accessories is for use by fire fighters, first responders, domestic preparedness and law enforcement officers, as well as industrial and hazardous material users.

PAK-ALERT SE 7 DISTRESS ALARM

The SCOTT PAK-ALERT SE 7 distress alarm consists of a sensor module mounted to the bottom of the respirator backframe, a pressure switch mounted between the cylinder and gauge line, and a control console mounted on the wearer's right shoulder strap at the pressure gauge location. The SCOTT PAK-ALERT SE 7 distress alarm reaches full alarm in a total of thirty (30) seconds after detecting that the respirator user is motionless. The alarm may also be activated manually.

The SCOTT PAK-ALERT SE 7 distress alarm is approved by the National Institute of Occupational Safety and Health (NIOSH) on all models of SCOTT SCBA except as specified in the limitations of use on the SCBA approval label and in the SCBA Operating and Maintenance Instructions.

NIOSH certified SCBA's are limited to a maximum weight of 35 lbs. When the PAK-ALERT SE 7 distress alarm is used with a one hour duration SCOTT SCBA, either the Kevlar¹ wrapped (SCOTT P/N 804222-01) or Carbon wrapped (P/N 804723-XX) cylinder and valve assembly must be used to keep the total weight under 35 lbs. limit. Using the PAK-ALERT SE 7 distress alarm with fiberglass wrapped one hour cylinder and valve assemblies, (SCOTT P/N 804107-01 or P/N 802827-01), will exceed 35 lbs.

Installation of a SCOTT PAK-ALERT SE 7 distress alarm on a SCOTT AIR-PAK SCBA requires some disassembly of the respirator. Installation instructions are included with the field installation kit available from your SCOTT distributor or from SCOTT HEALTH AND SAFETY.

OPTIONAL PAK-TRACKER LOCATOR SYSTEM

This unit may also be equipped with the optional SCOTT PAK-TRACKER Locator System as identified by the two round RED "Pak Tracker" labels on the Sensor Module. See FIGURE 2.

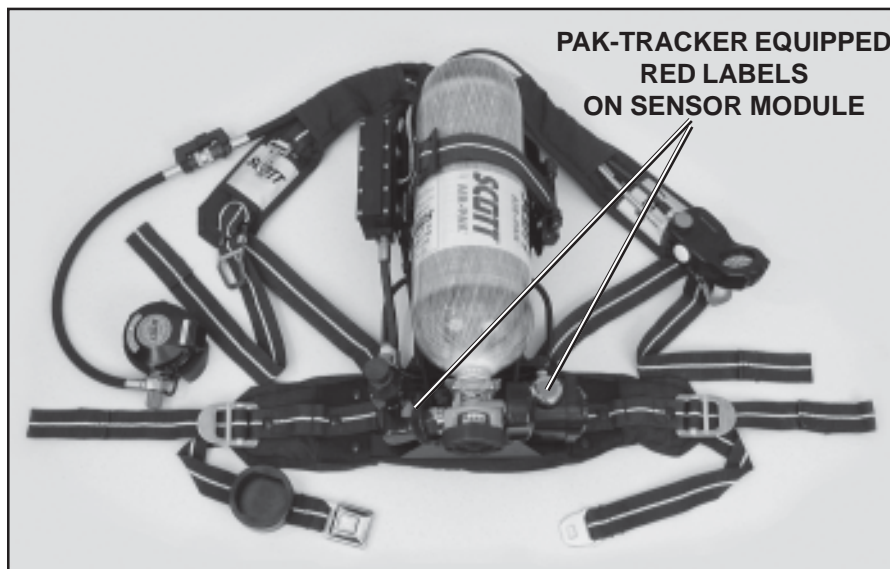

FIGURE 2
PAK-TRACKER EQUIPPED RED LABELS ON SENSOR MODULE

WARNING

DO NOT OPERATE THIS EQUIPMENT WHILE UNDER THE INFLUENCE OF DRUGS, ALCOHOL, OR ANY MEDICATIONS OR SUBSTANCES WHICH MAY AFFECT VISION, DEXTERITY, OR JUDGMENT. USERS OF THIS EQUIPMENT MUST BE IN GOOD PHYSICAL AND MENTAL HEALTH IN ORDER TO OPERATE SAFELY. DO NOT USE THIS EQUIPMENT WHEN FATIGUE PREVENTS SAFE OPERATION. STAY ALERT WHEN OPERATING THIS EQUIPMENT. INATTENTION OR CARELESSNESS WHILE OPERATING THIS EQUIPMENT MAY RESULT IN SERIOUS INJURY OR DEATH.

WARNING

NO PERSONAL ALERT SAFETY SYSTEM, RESPIRATOR OR COMBINATION OF PERSONAL ALERT SAFETY SYSTEM AND RESPIRATOR, BY THEMSELVES, CAN PROVIDE COMPLETE PROTECTION IN FIRE SITUATIONS. HOWEVER, USING AN ALARM AND A RESPIRATOR IN ACCORDANCE WITH THE REQUIREMENTS OF AN ORGANIZED RESPIRATORY PROTECTION PROGRAM IS ONE OF THE MANY SAFETY PRECAUTIONS WHICH SHOULD BE TAKEN TO AVOID PERSONAL INJURY OR DEATH.

WARNING

USERS OF RESPIRATORS EQUIPPED WITH THE PAK-ALERT SE 7 DISTRESS ALARM MUST BE AWARE OF THE PROPER OPERATION OF THE DISTRESS ALARM. IF THE GREEN LIGHT IS NOT FLASHING NORMALLY, OR IF THE UNIT EXHIBITS ANY OTHER SIGNS OF A MALFUNCTION WITHOUT THE USER TAKING PROPER CORRECTIVE ACTION, IT MAY LEAD TO CIRCUMSTANCES THAT RESULT IN SERIOUS INJURY OR DEATH.

¹ Kevlar is a registered trademark of E. I. Du Pont de Nemours, Inc.

The SCOTT PAK-TRACKER Locator System is a two part electronic system consisting of a PAK-TRACKER Transmitter integrated into the SCOTT PAK-ALERT SE 7 distress alarm, and a PAK-TRACKER Hand Held Receiver, which is a directional receiver used to locate the signal coming from the PAK-TRACKER Transmitter. The PAK-TRACKER locator system transmitter is activated with the PASS alarm. The transmitter emits a radio signal with a unique ID number that can be tracked using the SCOTT PAK-TRACKER Hand Held Receiver unit.

The PAK-TRACKER Hand Held Receiver is then used as a directional receiver to assist in leading the rescue team to the activated transmitter. By pointing the PAK-TRACKER Hand Held Receiver in the direction of the strongest relative signal, the rescue crew can follow the signal to the respirator user who is incapacitated or in need of assistance.



**FIGURE 3
PAK-TRACKER
HAND HELD RECEIVER**

Use of the PAK-TRACKER Locator System must be part of a complete personnel accountability system that includes procedures for monitoring the deployment and condition of all users. Do not rely on the PAK-TRACKER Locator System as the only technique for locating missing personnel. Failure to use this equipment properly may actually increase the time needed to locate and rescue personnel. TRAINING AND PRACTICE IN REALISTIC EMERGENCY SIMULATIONS IS REQUIRED BEFORE USE OF THIS EQUIPMENT. The users must become thoroughly familiar with the operation and the limitations of the locator system before entering a potentially hazardous or life threatening situation.

The PAK-TRACKER Locator System User Instructions, SCOTT part number 595102-01, contain essential information on the use of the locator system and must be used as the basis of training for use of the whole system including use with a PAK-ALERT SE 7 distress alarm equipped with the PAK-TRACKER Transmitter. The PAK-TRACKER Locator System User Instructions include an overview of the system operation, limitations of the system, as well as any user level maintenance for the PAK-TRACKER Locator System equipment. Copies of the PAK-TRACKER Locator System User Instructions are available from your SCOTT distributor or from SCOTT Health and Safety.

THE PAK-TRACKER HAND HELD RECEIVER IS A BATTERY OPERATED ELECTRICAL DEVICE THAT HAS NOT BEEN EVALUATED AS AN IGNITION SOURCE. DO NOT USE THE HAND HELD RECEIVER IN A POTENTIALLY EXPLOSIVE ATMOSPHERE. Always check for the presence of a flammable or explosive atmosphere before entering an unknown atmosphere with the Hand Held Receiver.

REGULAR OPERATIONAL INSPECTION

If your Pak-ALERT SE 7 is NOT equipped with the optional PAK-TRACKER Locator System, perform the REGULAR OPERATIONAL INSPECTION as defined on Page 12-13 of this instruction.

If your Pak-ALERT SE 7 IS equipped with the optional PAK-TRACKER Locator System (as signified by the two RED PAK-TRACKER labels on the Sensor Module), perform the REGULAR OPERATIONAL INSPECTION as defined on Page 14-15 of this instruction.

WARNING

READ AND UNDERSTAND THIS ENTIRE MANUAL AND THE PAK-TRACKER LOCATOR SYSTEM MANUAL, P/N 595102-01. TRAINING IS REQUIRED BEFORE USE OF THIS EQUIPMENT IN A HAZARDOUS SITUATION. THE TRAINING MUST INCLUDE AN UNDERSTANDING OF THE LIMITATIONS OF THE EQUIPMENT AND HOW TO INTERPRET LOCATING INFORMATION, ALONG WITH EXTENSIVE PRACTICE WITH THE SYSTEM IN A VARIETY OF ENVIRONMENTS. USE OF THIS EQUIPMENT MUST A PART OF A COMPLETE PERSONNEL ACCOUNTABILITY SYSTEM. ALWAYS UPDATE TRAINING WITH EACH NEW PIECE OF EQUIPMENT. USE OF A PAK-TRACKER LOCATOR SYSTEM WITHOUT PROPER TRAINING MAY PLACE THE USERS AT HIGHER RISK IN DANGEROUS SITUATIONS WHICH COULD RESULT IN SERIOUS INJURY OR DEATH.

WARNING

THE HAND HELD RECEIVER IS A BATTERY OPERATED ELECTRICAL DEVICE THAT HAS NOT BEEN EVALUATED AS AN IGNITION SOURCE. THIS DEVICE IS NOT TO BE USED IN A POTENTIALLY EXPLOSIVE ATMOSPHERE. ALWAYS CHECK FOR THE PRESENCE OF A FLAMMABLE OR EXPLOSIVE ATMOSPHERE BEFORE ENTERING AN UNKNOWN ATMOSPHERE WITH THE HAND HELD RECEIVER. USE OF THE HAND HELD RECEIVER IN A FLAMMABLE OR EXPLOSIVE ATMOSPHERE MAY RESULT IN IGNITION OF THE ATMOSPHERE RESULTING IN SERIOUS INJURY OR DEATH.

SAFETY LISTINGS

FCC COMPLIANCE

FCC Compliance Statement (Part 15.19)

This device complies with Part 15 of the FCC Rules. Operation is subject to the following two conditions:

1. This device may not cause harmful interference, and
2. This device must accept any interference received, including interference that may cause undesired operation.

FCC Warning (Part 15.21)

Changes or modifications not expressly approved by the party responsible for compliance could void the user's authority to operate the equipment.

This portable transmitter with its antenna complies with FCC's RF exposure limits for general population / uncontrolled exposure.

The Locator Integrated Transmitter has been assigned FCC ID # T5E200451.

CLASS B DIGITAL DEVICE

Note: This equipment has been tested and found to comply with the limits for a Class B digital device, pursuant to Part 15 of the FCC Rules. These limits are designed to provide reasonable protection against harmful interference in a residential installation. This equipment generates, uses and can radiate radio frequency energy and, if not installed and used in accordance with the instructions, may cause harmful interference to radio communications. However, there is no guarantee that interference will not occur in a particular installation. If this equipment does cause harmful interference to radio or television reception, which can be determined by turning the equipment off and on, the user is encouraged to try to correct the interference by one or more of the following measures:

- Reorient or relocate the receiving antenna
- Increase the separation between the equipment and receiver.
- Connect the equipment into an outlet on a circuit different from that to which the receiver is connected.
- Consult the dealer or an experienced radio/TV technician for help.

INDUSTRY CANADA COMPLIANCE

Industry Canada Statement

The term "IC" before the certification / registration number only signifies that the Industry Canada technical specifications were met.

Section 14 of RSS-210

The installer of this radio equipment must ensure that the antenna is located or pointed such that it does not emit RF field in excess of Health Canada limits for the general population. Consult Safety Code 6, obtainable from Health Canada's web site: www.hc-sc.gc.ca/rpb.

RADIO FREQUENCY INTERFERENCE (RFI)

When any electronic device is adversely affected by radio waves, Radio Frequency Interference (RFI) is said to have occurred. All electronic devices like the PAK-ALERT SE 7 distress alarm may be subject to the effects of RFI, most of which are temporary in nature. Users of the SCOTT AIR-PAK SCBA with the integrated PAK-ALERT SE 7 distress alarm must be familiar with the normal operation of the distress alarm and must also be familiar with how to identify and avoid the effects of RFI (see DETECTING AND AVOIDING RADIO FREQUENCY INTERFERENCE on page 6). If RFI occurs to the PAK-ALERT SE 7 distress alarm, it may be caused by transmissions from hand-held or personal radios where the radio antenna is touching or very close to (less than 6 inches from) components of the PAK-ALERT SE 7 distress alarm. It may also be caused by transmissions from base stations or high-powered vehicle mounted radios or any other powerful source of electromagnetic radiation.

WARNING

RADIO FREQUENCY INTERFERENCE (RFI) MAY CAUSE A MALFUNCTION OF THE PAK-ALERT SE 7 DISTRESS ALARM. USERS OF RESPIRATORS EQUIPPED WITH THE PAK-ALERT SE 7 DISTRESS ALARM MUST BE AWARE OF THE PROPER OPERATION OF THE DISTRESS ALARM. FAILURE TO RECOGNIZE A MALFUNCTION OF THE PAK-ALERT SE 7 DISTRESS ALARM AND TAKE PROPER CORRECTIVE ACTION MAY RESULT IN SERIOUS INJURY OR DEATH.

SAFETY LISTINGS Continued...

INTRINSICALLY SAFE LISTING

The PAK-ALERT SE 7 distress alarm with Integrated Locator transmitter, Model Number 200451-SERIES, when installed on a SCOTT respirator, is listed as intrinsically safe per ANSI/UL Std. UL-913 in Class I, Division 1 Groups A, B, C and D hazardous locations by SGS U. S. TESTING COMPANY, Inc. only when powered by the batteries listed in this instruction or indicated on the label on the sensor module.

To maintain Intrinsic Safety Listing, inspect the respirator with PAK-ALERT SE 7 distress alarm regularly per the Regular Operational Inspection procedures in this instruction. Substitution of Components May Impair Intrinsic Safety. To reduce the risk of ignition of a flammable atmosphere, batteries must only be changed in an area known to be nonflammable. To reduce the risk of explosion, use only the approved batteries, do not mix old batteries with unused batteries, or mix batteries from different manufacturers.

HAND HELD RECEIVER

THE HAND HELD RECEIVER HAS NOT BEEN EVALUATED FOR INTRINSIC SAFETY AS AN IGNITION SOURCE IN POTENTIALLY FLAMMABLE OR EXPLOSIVE ATMOSPHERES. DO NOT USE THE HAND HELD RECEIVER IN POTENTIALLY FLAMMABLE OR EXPLOSIVE ATMOSPHERES.

QUESTIONS OR CONCERNS

If you have any questions or concerns regarding use of this equipment, contact your authorized SCOTT dealer or distributor, or contact SCOTT at 1-800-247-7257 (or 704-291-8300 outside the continental United States) or visit our web site at www.scotthealthsafety.com.

Report any operational malfunctions of the PASS function of this device to the certification agency Safety Equipment Institute (SEI), 1307 Dolley Madison Blvd. Suite 3A, McLean, VA 22101, (703) 442-5732, FAX (703) 442-5756.

WARNING

IF THE PAK-ALERT SE 7 DISTRESS ALARM IS USED IN AN AREA OF EXPLOSIVE OR FLAMMABLE HAZARDS, FAILURE TO REGULARLY INSPECT AS INSTRUCTED, FAILURE TO CORRECT DAMAGE BEFORE USE, OR THE INSTALLATION OF INCORRECT BATTERIES MAY LEAD TO A FIRE OR EXPLOSION WHICH MAY RESULT IN PERSONAL INJURY OR DEATH.

WARNING

THE HAND HELD RECEIVER IS A BATTERY OPERATED ELECTRICAL DEVICE THAT HAS NOT BEEN EVALUATED FOR INTRINSIC SAFETY AS AN IGNITION SOURCE IN A POTENTIALLY FLAMMABLE OR EXPLOSIVE ATMOSPHERE. DO NOT USE THE HAND HELD RECEIVER IN A POTENTIALLY EXPLOSIVE ATMOSPHERE. ALWAYS CHECK FOR THE PRESENCE OF A FLAMMABLE OR EXPLOSIVE ATMOSPHERE BEFORE ENTERING AN UNKNOWN ATMOSPHERE WITH THE HAND HELD RECEIVER. USE OF THE HAND HELD RECEIVER IN A FLAMMABLE OR EXPLOSIVE ATMOSPHERE MAY RESULT IN IGNITION OF THE ATMOSPHERE RESULTING IN SERIOUS INJURY OR DEATH.

OPERATION OF THE SCOTT PAK-ALERT SE 7 DISTRESS ALARM

With proper batteries and a charged air cylinder installed, the PAK-ALERT SE 7 distress alarm device is automatically activated when the respirator is pressurized by opening the cylinder valve of the respirator.

To indicate activation, the sensor module will sound 3 quick audible chirps and the green light located on the control console will flash approximately once a second. See FIGURE 4. The PAK-ALERT SE 7 distress alarm is now in the automatic mode.

In the automatic mode, the SCOTT PAK-ALERT SE 7 distress alarm constantly monitors motion of the respirator backframe. The sensor module is located on the respirator backframe beneath the air cylinder and contains the motion sensor and the audible alarm. If the sensor module does not sense motion of the respirator for twenty (20) seconds, the PAK-ALERT SE 7 distress alarm will signal a pre-alarm condition. If there is still no motion of the respirator for the next twelve (12) seconds the full alarm will sound.

The SCOTT PAK-ALERT SE 7 distress alarm will remain activated in the automatic mode until turned OFF according to these instructions.

WARNING

THE INFORMATION BELOW IS MEANT TO SUPPLEMENT, NOT REPLACE, THE TRAINING, SUPERVISION, MAINTENANCE, AND OTHER ELEMENTS OF YOUR ORGANIZED RESPIRATORY PROTECTION PROGRAM. SEE WARNING ON FIRST PAGE OF THIS DOCUMENT. FAILURE TO COMPLY WITH THESE INSTRUCTIONS MAY RESULT IN SERIOUS INJURY OR DEATH.

WARNING

USERS OF RESPIRATORS EQUIPPED WITH THE PAK-ALERT SE 7 DISTRESS ALARM MUST BE AWARE OF THE PROPER OPERATION OF THE DISTRESS ALARM. FAILURE TO RECOGNIZE A MALFUNCTION OF THE PAK-ALERT SE 7 DISTRESS ALARM AND TAKE PROPER CORRECTIVE ACTION MAY RESULT IN SERIOUS INJURY OR DEATH.

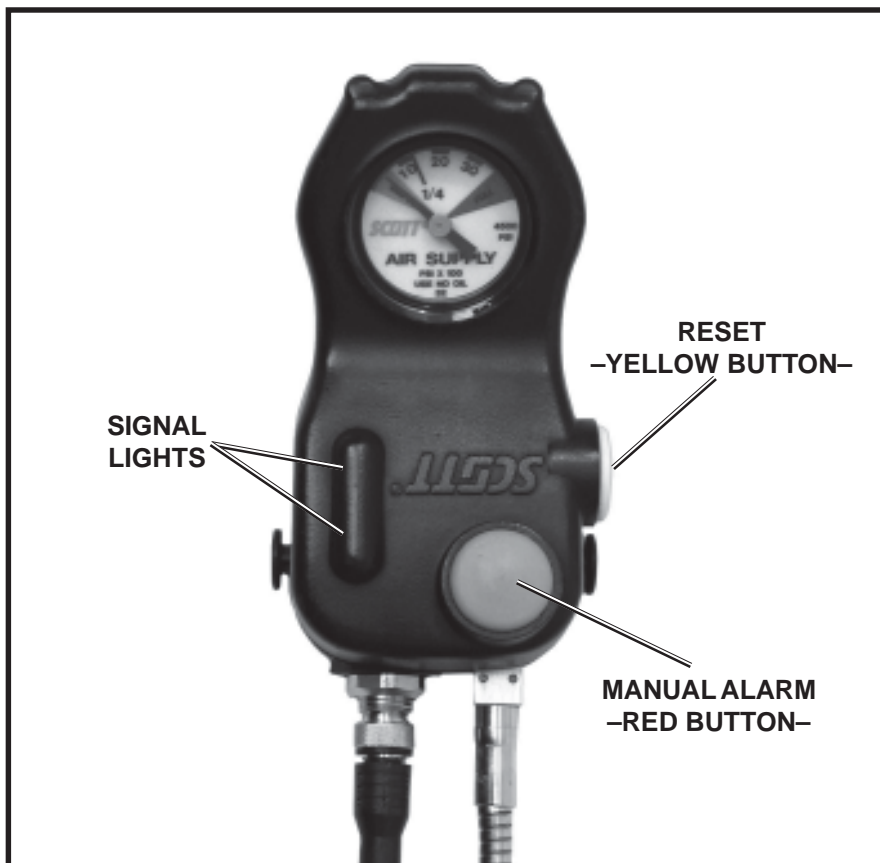

FIGURE 4
THE CONTROL CONSOLE

PRE-ALARM

If the respirator remains motionless for more than twenty (20) seconds, the PAK-ALERT SE 7 distress alarm will automatically sound a pre-alarm

When the pre-alarm occurs, the green flashing light on the control console is replaced by a bright red light which flashes approximately once a second and is accompanied by an ascending/descending audible tone which increases in volume during the pre-alarm cycle.

If the respirator user is not incapacitated or not in need of assistance, move the respirator to reset the pre-alarm. When reset, the flashing red light will be replaced by the flashing green and the ascending/descending tone will stop.

Remember that the motion sensor is in the sensor module on the respirator backframe beneath the air cylinder. Actual movement of the respirator backframe is required to reset the pre-alarm. Shaking the control console will not reset the PAK-ALERT SE 7 distress alarm .

To manually reset the pre-alarm, press and hold the reset button on the side of the control console until three (3) quick audible chirps are heard and the red flashing light on the control console is replaced by the green flashing light.

FULL ALARM

If the respirator remains motionless through the twelve (12) second pre-alarm cycle, the PAK-ALERT SE 7 distress alarm will go into full alarm. This may indicate that the user is incapacitated or in need of assistance and can not move.

Full alarm is indicated by a loud, almost continuous 3 tone chirp from the sensor module accompanied by the flashing red signal light on the control console. Ten (10) seconds after the full alarm condition starts, the Locator Transmitter will begin to transmit the unique ID number for the unit. To reset the full alarm condition, press the reset button **twice**. See FIGURE 4.

After the full alarm has been silenced by pressing the reset button twice, the PAK-ALERT SE 7 distress alarm will remain activated in the automatic mode with the green light flashing once per second. As long as the respirator is pressurized, there must be movement of the respirator at least every twenty (20) seconds or the distress alarm will again go into pre-alarm followed by full alarm as described above.

MANUAL ALARM

If the respirator user requires immediate assistance, pressing the manual alarm button located on the front of the control console will immediately sound the full alarm. See FIGURE 4. The manual alarm may be activated at any time, even when the respirator is not pressurized.

If the manual alarm is activated when the respirator is not pressurized, press the reset button **twice** to silence the alarm. The PAK-ALERT SE 7 distress alarm will remain on in automatic mode. To turn the unit off, press the reset **twice** again while the unit is not in alarm mode.

Remember, the loud audible alarm and flashing red light can be turned on at any time by pressing the manual alarm button on the control console.

WARNING

USERS OF RESPIRATORS EQUIPPED WITH THE PAK-ALERT SE 7 DISTRESS ALARM MUST BE AWARE OF THE PROPER OPERATION OF THE DISTRESS ALARM. FAILURE TO RECOGNIZE A MALFUNCTION OF THE PAK-ALERT SE 7 DISTRESS ALARM AND TAKE PROPER CORRECTIVE ACTION MAY RESULT IN SERIOUS INJURY OR DEATH.

**OPERATION OF THE PAK-ALERT SE 7 DISTRESS ALARM
CONTINUED ON NEXT PAGE...**

OPERATION OF THE PAK-ALERT SE 7 DISTRESS ALARM CONTINUED...

TO TURN OFF THE PAK-ALERT SE 7 DISTRESS alarm

When use of the respirator with the PAK-ALERT SE 7 distress alarm is no longer required, close the cylinder valve on the respirator and vent the residual air from the respirator system by opening the regulator purge valve. After all the air flow stops, close the regulator purge valve and press the reset button twice to turn off the PAK-ALERT SE 7 distress alarm. If there is air pressure left in the system, the green flashing light will continue to flash while a fifteen second beep sequence is heard from the sensor module as the residual air bleeds from the system. As soon as the air has completely bled from system, the unit will sound a quick two tone chirp and the PASS DEVICE distress alarm will be inactive. If there is no pressure in the system when the RESET button is pressed twice, there will be no fifteen second beep sequence. When the unit sounds a quick two tone chirp, the PAK-ALERT SE 7 distress alarm is inactive. If there is any air pressure left in the system, the PASS DEVICE distress alarm will return to the active mode.

If the respirator cylinder valve is open and/or pressure remains in the respirator, the PAK-ALERT SE 7 distress alarm can not be turned off. Pressing the reset button when the respirator is pressurized will only reset an alarm condition and return the PAK-ALERT SE 7 distress alarm to automatic mode. If the respirator cylinder is turned off and depressurized without pressing the reset button twice, the PAK-ALERT SE 7 distress alarm will continue to monitor motion in automatic mode. This means that the PAK-ALERT SE 7 distress alarm may be used to monitor motion after the respirator is turned off and depressurized. Resetting the full alarm after the respirator has been depressurized will not turn off the PAK-ALERT SE 7 distress alarm. Press the reset switch twice with no alarm condition to turn off the PAK-ALERT SE 7 distress alarm (there will be no fifteen (15) second beep sequence and two tone chirp will be heard).

LOW BATTERY

In a low battery condition, the PAK-ALERT SE 7 distress alarm will produce a single audible chirp from the sensor module once every two (2) seconds and the green light on the control module will not flash.

While in low battery condition, the PAK-ALERT SE 7 distress alarm will continue to operate for a period of time greater than the longest duration cylinder available for the respirator. However, the batteries must be replaced before the respirator is used again. See THE BATTERY REPLACEMENT section of these instructions.

If batteries are completely discharged or have not been installed, there will be no light or sound and the unit will not operate.

BATTERY TEST

To test the batteries, verify that the PAK-ALERT SE 7 distress alarm is in the off condition (cylinder valve closed with no flashing green LED on the control console). Press and hold the reset button on the console.

A green light on the console will illuminate to indicate sufficient battery power remaining. If a red light appears, the batteries must be replaced before the respirator is used again.

DATA LOGGING FEATURE

Respirators equipped with a SCOTT PAK-ALERT SE 7 distress alarm integrated PASS device are compliant to NFPA 1982, 2007 Edition. The PASS device includes on-board electronics which maintain a running log of event data including start-up, shut-down, and PASS activation. The SCOTT DATA LOGGER Computer Interface is required to access the information. Instructions for downloading the data log are SCOTT P/N 595123-01 and are included with the computer interface.

WARNING

FAILURE TO REPLACE THE BATTERIES AND/OR CONTINUING WITH MULTIPLE USES OF THE RESPIRATOR AFTER THE LOW BATTERY CONDITION HAS BEEN INDICATED BY THE PAK-ALERT SE 7 DISTRESS ALARM MAY RESULT IN FAILURE OF THE PAK-ALERT SE 7 DISTRESS ALARM DURING USE AND POSSIBLE INJURY OR DEATH OF THE USER.

USE OF THE OPTIONAL SCOTT PAK-TRACKER LOCATOR SYSTEM

USE AS PART OF AN ACCOUNTABILITY SYSTEM

TRAINING REQUIRED BEFORE USE. Refer to the PAK-TRACKER Locator System User Instructions, SCOTT P/N 595102-01 for complete details on the use of the PAK-TRACKER Locator System. Use of this equipment must be part of a complete personnel accountability system that includes procedures for monitoring the deployment and condition of all users. Do not rely on the PAK-TRACKER Locator System as the only technique for locating missing personnel. A Rapid Intervention or Rescue team using the Hand Held Receiver must have a minimum of two (2) people. For their own safety, the team members must pay attention to their surroundings at all times while using the PAK-TRACKER Locator System.

The accountability system must include procedures for alerting the incident commander and rescue teams when actuated transmitters or the missing personnel have been found or when they have moved from their previous location. It is the responsibility of the personnel accountability system to allow for such contingencies without exposing individuals and teams to unnecessary dangers.

RESTRICTED USE IN SOME LOCATIONS

The Hand Held Receiver is not suitable for use in potentially flammable or explosive atmospheres. Always check for the presence of a flammable or explosive atmosphere before entering an unknown atmosphere with the Hand Held Receiver.

PRINCIPLES OF OPERATION

OF THE PAK-TRACKER LOCATOR SYSTEM

The SCOTT PAK-TRACKER locator system is a two part electronic system consisting of a Hand Held Receiver and a Transmitter. When a Transmitter is activated, it sends out a radio signal in all directions that is received by the Hand Held Receiver. Understanding how the radio signal from a Transmitter behaves and how the Hand Held Receiver receives and displays the strength of that signal are critical to understanding the operation of the SCOTT PAK-TRACKER locator system. Successful operation of the PAK-TRACKER Locator system depends heavily on the interpretation of the relative signal strength information displayed on the Hand Held Receiver along with all other available information about the possible location of the activated transmitter.

The Hand Held Receiver is very sensitive in responding to small differences in signal strength. The relative strength of the Transmitter signal detected by the Hand Held Receiver will vary depending on:

1. The distance from the Transmitter to the Hand Held Receiver,
2. The path the Transmitter signal has taken to get to the Hand Held Receiver,
3. The materials between the Transmitter and the Hand Held Receiver which may have affected the signal from the Transmitter.

The user of the Hand Held Receiver must interpret the readings on the Hand Held Receiver display along with other information, such as:

- training and knowledge in systematic search and rescue techniques,
- their sense of sight (watch where you are going),
- their sense of sound (listen for an activated PASS device),
- the deployment of the missing personnel,
- knowledge of the building layout and building materials,

Do not rely solely on the readings from the Hand Held Receiver to locate the activated Transmitter.

Refer to the PAK-TRACKER Locator System User Instructions, SCOTT P/N 595102-01 for complete details on the use of the PAK-TRACKER Locator System.

WARNING

READ AND UNDERSTAND THIS ENTIRE MANUAL AND THE PAK-TRACKER LOCATOR SYSTEM MANUAL, P/N 595102-01. TRAINING IS REQUIRED BEFORE USE OF THIS EQUIPMENT IN A HAZARDOUS SITUATION. THE TRAINING MUST INCLUDE AN UNDERSTANDING OF THE LIMITATIONS OF THE EQUIPMENT AND HOW TO INTERPRET LOCATING INFORMATION, ALONG WITH EXTENSIVE PRACTICE WITH THE SYSTEM IN A VARIETY OF ENVIRONMENTS. USE OF THIS EQUIPMENT MUST A PART OF A COMPLETE PERSONNEL ACCOUNTABILITY SYSTEM. ALWAYS UPDATE TRAINING WITH EACH NEW PIECE OF EQUIPMENT. USE OF A PAK-TRACKER LOCATOR SYSTEM WITHOUT PROPER TRAINING MAY PLACE THE USERS AT HIGHER RISK IN DANGEROUS SITUATIONS WHICH COULD RESULT IN SERIOUS INJURY OR DEATH.

WARNING

DO NOT USE THE HAND HELD RECEIVER IN A POTENTIALLY EXPLOSIVE OR FLAMMABLE ATMOSPHERE. ALWAYS CHECK FOR THE PRESENCE OF A FLAMMABLE OR EXPLOSIVE ATMOSPHERE BEFORE ENTERING AN UNKNOWN ATMOSPHERE WITH THE HAND HELD RECEIVER. USE OF THE HAND HELD RECEIVER IN A FLAMMABLE OR EXPLOSIVE ATMOSPHERE MAY RESULT IN IGNITION OF THE ATMOSPHERE RESULTING IN SERIOUS INJURY OR DEATH.

WARNING

CONTINUED TRAINING AND PRACTICE IN A VARIETY OF SITUATIONS IS ESSENTIAL TO DEVELOPING THE SKILLS TO PROPERLY INTERPRET THE INFORMATION PROVIDED BY THE PAK-TRACKER LOCATOR SYSTEM. USE OF THIS EQUIPMENT WITHOUT TRAINING AND PRACTICE MAY JEOPARDIZE ALL PERSONNEL INVOLVED WHICH COULD LEAD TO SERIOUS INJURY OR DEATH.

DETECTING AND AVOIDING RADIO FREQUENCY INTERFERENCE

When any electronic device is adversely affected by radio waves, Radio Frequency Interference (RFI) is said to have occurred. All electronic devices like the PAK-ALERT SE 7 distress alarm may be subject to the effects of RFI. Radio transmissions from the antennas of radios including those used by fire fighters, police and other public safety related personnel may produce RFI in the PAK-ALERT SE 7 distress alarm. RFI may occur while the radio is transmitting if the respirator equipped with the PAK-ALERT SE 7 distress alarm is in close proximity to a base station or high-powered vehicle mounted radio, or if the antenna of a personal portable hand held radio is touching or within six (6) inches of the Control Console or Sensor Module of the PAK-ALERT SE 7 distress alarm. See FIGURE 5.

Be aware of the symptoms of RFI. A PAK-ALERT SE 7 distress alarm affected by RFI may temporarily give false indications such as the sudden sounding of the loud continuous three-tone chirp of the full alarm. In some instances the lights on the control console may flash without sounding the alarm. In rare circumstances, an alarm which was sounding may stop.

If the PAK-ALERT exhibits any of the symptoms of RFI, identify the source of the RFI and do the following:

- If the symptoms of RFI occur when standing near a base station transmitting antenna or a truck mounted radio antenna, move away from the antenna until the symptoms stop.
- If the symptoms of RFI occur while transmitting on a hand-held radio, move the radio away from the PAK-ALERT .

CHECK THE CONTROL CONSOLE AND BE CERTAIN THE GREEN LIGHT IS FLASHING NORMALLY WHEN THE INTERFERENCE STOPS, REGARDLESS OF THE SOURCE.

In normal usage with the air cylinder open, the PAK-ALERT SE 7 distress alarm will typically resume normal operation after experiencing RFI.

WARNING

KEEP THE ANTENNAS OF HAND-HELD RADIOS AT LEAST SIX (6) INCHES AWAY FROM THE CONTROL CONSOLE AND THE SENSOR MODULE OF THE PAK-ALERT SE 7 DISTRESS ALARM WHEN TRANSMITTING. CLOSE PROXIMITY OF RADIO EQUIPMENT TO THE PAK-ALERT SE 7 DISTRESS ALARM DURING RADIO TRANSMISSION MAY CAUSE THE UNIT TO MALFUNCTION. FAILURE TO RECOGNIZE A MALFUNCTION OF THE PAK-ALERT SE 7 DISTRESS ALARM AND TAKE THE PROPER CORRECTIVE ACTION MAY RESULT A NON-WORKING DISTRESS ALARM WHICH WILL NOT SOUND IF THE USER STOPS MOVING AND LEAD TO SERIOUS INJURY OR DEATH.

WARNING

BE AWARE OF THE POTENTIAL EFFECT OF RADIO TRANSMISSIONS FROM BASE STATION OR TRUCK MOUNT RADIOS WHEN USING A RESPIRATOR WITH THE PAK-ALERT SE 7 DISTRESS ALARM. CLOSE PROXIMITY OF RADIO EQUIPMENT TO THE PAK-ALERT SE 7 DISTRESS ALARM DURING RADIO TRANSMISSION MAY CAUSE THE UNIT TO MALFUNCTION. FAILURE TO RECOGNIZE A MALFUNCTION OF THE PAK-ALERT SE 7 DISTRESS ALARM AND TAKE THE PROPER CORRECTIVE ACTION MAY RESULT A NONWORKING DISTRESS ALARM WHICH WILL NOT SOUND IF THE USER STOPS MOVING AND LEAD TO SERIOUS INJURY OR DEATH.

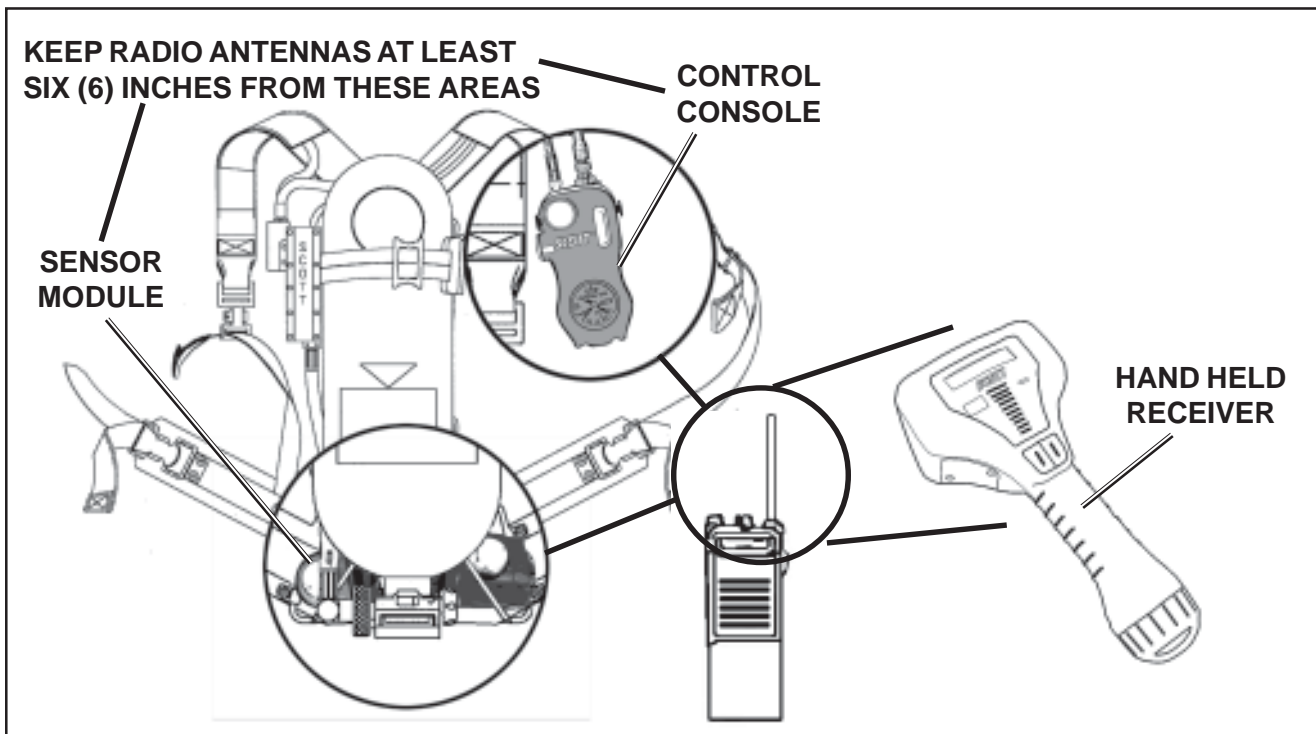

**FIGURE 5
RFI WARNING AREAS**

If the PAK-ALERT SE 7 distress alarm is affected by RFI when the respirator air supply is turned off or the cylinder is empty, the distress alarm could be turned off during use. If this occurs, depress the RED Manual Alarm Button to activate the alarm.

IF THE SYMPTOMS OF RFI OCCUR, THE RESPIRATOR USER MUST CHECK THE PAK-ALERT SE 7 DISTRESS ALARM TO VERIFY THAT IT IS FUNCTIONING PROPERLY. IF THE GREEN LIGHT ON THE CONTROL CONSOLE DOES NOT RESUME FLASHING IN THE NORMAL MANNER AFTER EXPERIENCING THE SYMPTOMS OF RFI, OR IF THE UNIT CONTINUES TO MALFUNCTION IN ANY OTHER WAY, PROCEED TO A SAFE AREA, REMOVE THE RESPIRATOR FROM SERVICE AND TAG FOR REPAIR BY AUTHORIZED PERSONNEL.

Minimize or eliminate the effects of RFI by protecting the PAK-ALERT with the following steps:

- Maintain a safe distance from a base station transmitting antenna or a truck mounted radio antenna.
- Keep the antennas of hand held radios at least six (6) inches away from the CONTROL CONSOLE or the SENSOR MODULE. See FIGURE 5.

RFI AND THE PAK-TRACKER HAND HELD RECEIVER

If the Hand Held Receiver experiences RFI, it may be necessary to remove the Hand Held Receiver from service. In a known safe, non-hazardous area, remove and reinstall the batteries to reset the unit (see the BATTERY REPLACEMENT section of the PAK-TRACKER Locator System User Instructions, SCOTT P/N 595102-01). Then inspect and return the Hand Held Receiver to service.

REGULAR OPERATIONAL INSPECTION

INSPECTION OF A PAK-ALERT SE 7 DISTRESS ALARM

Inspect and test the SCOTT PAK-ALERT SE 7 distress alarm along with the inspection and test of the SCOTT SCBA respirator before each use. Include the following inspection procedures with the REGULAR OPERATIONAL INSPECTION procedures defined in your respirator instructions. If any malfunction of the respirator or the PAK-ALERT SE 7 distress alarm is noted during the inspection, remove the respirator from service and tag for repair by authorized personnel.

NOTE

IN SEVERAL OF THE INSPECTION PROCEDURES DESCRIBED A FULL ALARM WILL BE OBSERVED. THE FULL ALARM CONDITION INCLUDES AN AUDIBLE TONE THAT CAN EXCEED 95 DBA AT 3 METERS (9.9 FT.). TO PREVENT POSSIBLE HEARING DAMAGE DURING TEST, IMMEDIATELY RESET THE ALARM ON VERIFICATION THAT IT IS FUNCTIONING PROPERLY. WEAR HEARING PROTECTION IF PROLONGED EXPOSURE TO A FULL ALARM CONDITION IS ANTICIPATED.

NOTE

IF THIS INSPECTION IS DONE IN DIRECT SUNLIGHT IT MAY BE HELPFUL TO SHADE THE LENS ON THE CONTROL CONSOLE WITH YOUR HAND TO BE SURE THE LIGHTS ARE FLASHING AS DESCRIBED.

1. While performing the visual inspection of the respirator, visually inspect all distress alarm enclosures, lenses, and wire conduits for cracks, wear or other damage. If any damage is found, remove the respirator from service and tag for repair by qualified personnel.
2. With the cylinder valve closed, press the manual alarm button, located on the front of the distress alarm control console. The manual alarm shall sound a loud almost continuous 3 tone chirp accompanied by flashing of the red signal light on the control console.
4. Reset the manual alarm by pressing **twice** on the reset button located on the side of the control console (**fully depress reset button, release and press again**). The unit will sound three chirps and the green light will flash.
5. Turn the PAK-ALERT SE 7 distress alarm OFF by pressing the reset button **twice** again. The unit will sound a two tone chirp and the green light will go out.
6. Open the cylinder valve to pressurize the respirator system. The distress alarm shall sound 3 quick chirps and the light on the control console shall begin flashing green about once a second. The 3 chirps will sound approximately the same time the VIBRALERT® in the mask mounted regulator actuates briefly. Make sure the air flow is stopped by pressing the air saver/donning switch.
7. To check the pre-alarm, leave respirator motionless for twenty (20) seconds. The green flashing light shall be replaced by a red flashing light. An ascending/descending tone will sound increasing in volume. Leave the respirator motionless.
8. After the pre-alarm condition occurs, check the pre-alarm reset. Within twelve (12) seconds of the pre-alarm, move the respirator to activate the motion sensor. The PAK-ALERT SE 7 distress alarm shall reset to the automatic mode. The red flashing light shall be replaced by a green flashing light and the ascending/descending tone shall stop. Continue with regular operational inspection of respirator as directed by respirator instructions or your approved respiratory protection plan procedure. During the inspection the respirator must be moved or turned every thirty (30) seconds or less to prevent the sounding of the full alarm.

WARNING

FOLLOW REGULAR OPERATIONAL INSPECTION PROCEDURE EXACTLY. IF THE PAK-ALERT SE 7 DISTRESS ALARM DOES NOT ACTUATE, OR DOES NOT OPERATE AS DESCRIBED OR IF ANY OTHER OPERATIONAL MALFUNCTION IS NOTED, DO NOT USE THE RESPIRATOR.

WARNING

THE PROPER OPERATION OF THE LOCATOR SYSTEM CANNOT BE CHECKED WITHOUT CHECKING ALL COMPONENTS OF THE SYSTEM TOGETHER. THE REGULAR OPERATIONAL INSPECTION MUST INCLUDE THE HAND HELD RECEIVER AND THE TRANSMITTERS IN THE PAK-TRACKER LOCATOR SYSTEM SPECIALLY EQUIPPED PAK-ALERT SE 7 DISTRESS ALARM WORKING WITH EACH OTHER TO CONFIRM PROPER OPERATION. FAILURE TO PROPERLY INSPECT THE COMPLETE SYSTEM MAY RESULT IN FAILURE OF ONE COMPONENT WHICH COULD LEAD TO SERIOUS INJURY OR DEATH.

CAUTION

THE PERFORMANCE PROPERTIES OF THE PAK-ALERT SE 7 DISTRESS ALARM CANNOT BE PROPERLY TESTED IN THE FIELD.

WARNING

IN SEVERAL OF THE INSPECTION PROCEDURES DESCRIBED A FULL ALARM WILL BE OBSERVED. THE FULL ALARM CONDITION INCLUDES AN AUDIBLE TONE THAT CAN EXCEED 95 DBA AT 3 METERS (9.9 FT.). TO PREVENT POSSIBLE HEARING DAMAGE DURING TEST, IMMEDIATELY RESET THE ALARM ON VERIFICATION THAT IT IS FUNCTIONING PROPERLY. WEAR HEARING PROTECTION IF PROLONGED EXPOSURE TO A FULL ALARM CONDITION IS ANTICIPATED.

After completion of all respirator checks and before turning off the cylinder valve:

1. Check the manual reset of the pre-alarm. Leave the respirator motionless until pre-alarm condition occurs. Within twelve (12) seconds press and **hold** the reset button. Three (3) chirps shall sound, then release button. The distress alarm shall reset to the automatic mode and the flashing red light will be replaced by a flashing green light.
2. To check the full alarm, leave the respirator motionless until the pre-alarm condition occurs. Do not reset. The full alarm shall sound a loud almost continuous 3 tone chirp accompanied by flashing of the red signal light on the control console.
3. Reset the full alarm by pressing **twice** on the reset button located on the side of the control console (**fully depress reset button, release and press again**). The loud alarm shall stop. The unit will sound three chirps and the green light will flash. The unit shall reset to the automatic mode.
4. Finish all respirator checks involving air flow and turn off the cylinder valve. Use the purge valve to release all residual air pressure in the system.

With the cylinder valve OFF:

1. Check the continuing operation of the distress alarm. The distress alarm shall remain active with green light flashing. Do not move respirator, pre-alarm shall occur with twenty (20) seconds. Move respirator slightly, pre-alarm shall reset, green light shall start flashing again.
2. To turn the distress alarm off, press the reset button **twice** (press, release and press again). If there is air pressure left in the system, the green flashing light will continue to flash while a fifteen second beep sequence is heard from the sensor module as the residual air bleeds from the system. As soon as the air has completely bled from system, the unit will sound a quick two tone chirp and the PAK-ALERT SE 7 distress alarm will be inactive. If there is no air pressure in the system when the RESET button is pressed twice, there will be no beep sequence, only the quick two tone chirp. The distress alarm is now in the "OFF" condition. If there is any air pressure left in the system, the PAK-ALERT SE 7 distress alarm will return to the active mode.

NOTE

IF THE LOW BATTERY INDICATION (ONE STEADY CHIRP EVERY TWO (2) SECONDS WITH NO FLASHING LIGHTS) OCCURS AT ANY TIME DURING REGULAR OPERATIONAL INSPECTION, DO NOT USE THE RESPIRATOR. CHANGE THE BATTERIES IN THE SENSOR MODULE IMMEDIATELY AND REPEAT THE REGULAR OPERATIONAL TEST OR TAKE THE RESPIRATOR OUT OF SERVICE UNTIL THE BATTERIES ARE CHANGED AND THE REGULAR OPERATIONAL TEST IS SUCCESSFULLY PERFORMED.

WARNING

IF THE LOW BATTERY INDICATION (ONE STEADY CHIRP EVERY TWO (2) SECONDS WITH NO FLASHING LIGHTS) OCCURS AT ANY TIME DURING REGULAR OPERATIONAL INSPECTION, DO NOT USE THE RESPIRATOR. CHANGE THE BATTERIES IN THE SENSOR MODULE IMMEDIATELY AND REPEAT THE REGULAR OPERATIONAL TEST OR TAKE THE RESPIRATOR OUT OF SERVICE UNTIL THE BATTERIES ARE CHANGED AND THE REGULAR OPERATIONAL TEST IS SUCCESSFULLY PERFORMED.

**REGULAR OPERATIONAL INSPECTION
FOR A PAK-ALERT SE 7 DISTRESS ALARM WITH
OPTIONAL PAK-TRACKER LOCATOR SYSTEM
CONTINUED ON NEXT PAGE...**

REGULAR OPERATIONAL INSPECTION CONTINUED...

INSPECTION OF A PAK-ALERT SE 7 DISTRESS ALARM WITH OPTIONAL PAK-TRACKER LOCATOR SYSTEM

Inspect and test the SCOTT PAK-TRACKER Locator System specially equipped PAK-ALERT SE 7 distress alarm along with the inspection and test of the SCOTT SCBA respirator before each use. Include the following inspection procedures with the REGULAR OPERATIONAL INSPECTION procedures defined in your respirator instructions. If any malfunction of the respirator, the PAK-TRACKER Locator System, or the PAK-ALERT SE 7 distress alarm is noted during the inspection, remove the respirator from service and tag for repair by authorized personnel.

To test the PAK-TRACKER locator transmitter, you must have an operating SCOTT PAK-TRACKER Hand Held Receiver.

NOTE

IN SEVERAL OF THE INSPECTION PROCEDURES DESCRIBED A FULL ALARM WILL BE OBSERVED. THE FULL ALARM CONDITION INCLUDES AN AUDIBLE TONE THAT CAN EXCEED 95 DBA AT 3 METERS (9.9 FT.). TO PREVENT POSSIBLE HEARING DAMAGE DURING TEST, IMMEDIATELY RESET THE ALARM ON VERIFICATION THAT IT IS FUNCTIONING PROPERLY. WEAR HEARING PROTECTION IF PROLONGED EXPOSURE TO A FULL ALARM CONDITION IS ANTICIPATED.

NOTE

IF THIS INSPECTION IS DONE IN DIRECT SUNLIGHT IT MAY BE HELPFUL TO SHADE THE LENS ON THE CONTROL CONSOLE WITH YOUR HAND TO BE SURE THE LIGHTS ARE FLASHING AS DESCRIBED.

1. While performing the visual inspection of the respirator, visually inspect all distress alarm enclosures, lenses, and wire conduits for cracks, wear or other damage. If any damage is found, remove the respirator from service and tag for repair by qualified personnel.
2. Turn on the SCOTT PAK-TRACKER Hand Held Receiver according to the operating instructions provided with the unit. Position the Hand Held Receiver near by.
3. With the cylinder valve closed, press the manual alarm button, located on the front of the distress alarm control console.
 - a) The manual alarm shall sound a loud almost continuous 3 tone chirp accompanied by flashing of the red signal light on the control console.
 - b) The PAK-TRACKER Hand Held Receiver will sound an alarm and display the Identification Number of the PAK-TRACKER Locator System specially equipped PAK-ALERT SE 7 distress alarm which appears on the label on the Sensor Module or the Control Console. Use the SCROLL button on the Hand Held Receiver to highlight the active ID number and press the ENTER button on the Hand Held Receiver to select the displayed ID number. Point the unit directly at and in close proximity to the respirator. The signal strength displayed will be at its highest value.
4. Reset the manual alarm by pressing **twice** on the reset button located on the side of the control console (**fully depress reset button, release and press again**).
 - a) The unit will sound three chirps and the green light will flash.
 - b) The PAK-TRACKER Hand Held Receiver will reset to its non-alarm state.
5. Turn the PAK-TRACKER Locator System specially equipped PAK-ALERT SE 7 distress alarm OFF by pressing the reset button **twice** again. The unit will sound a two tone chirp and the green light will go out.
6. Open the cylinder valve to pressurize the respirator system. The distress alarm shall sound 3 quick chirps and the light on the control console shall begin flashing green about once a second. The 3 chirps will sound approximately the same time the VIBRALERT® in the mask mounted regulator actuates briefly. Make sure the air flow is stopped by pressing the air saver/donning switch.

WARNING

FOLLOW REGULAR OPERATIONAL INSPECTION PROCEDURE EXACTLY. IF THE PAK-ALERT SE 7 DISTRESS ALARM DOES NOT ACTUATE, OR DOES NOT OPERATE AS DESCRIBED OR IF ANY OTHER OPERATIONAL MALFUNCTION IS NOTED, DO NOT USE THE RESPIRATOR.

WARNING

THE PROPER OPERATION OF THE LOCATOR SYSTEM CANNOT BE CHECKED WITHOUT CHECKING ALL COMPONENTS OF THE SYSTEM TOGETHER. THE REGULAR OPERATIONAL INSPECTION MUST INCLUDE THE HAND HELD RECEIVER AND THE TRANSMITTERS IN THE PAK-TRACKER LOCATOR SYSTEM SPECIALLY EQUIPPED PAK-ALERT SE 7 DISTRESS ALARM WORKING WITH EACH OTHER TO CONFIRM PROPER OPERATION. FAILURE TO PROPERLY INSPECT THE COMPLETE SYSTEM MAY RESULT IN FAILURE OF ONE COMPONENT WHICH COULD LEAD TO SERIOUS INJURY OR DEATH.

CAUTION

THE PERFORMANCE PROPERTIES OF THE PAK-ALERT SE 7 DISTRESS ALARM CANNOT BE PROPERLY TESTED IN THE FIELD.

WARNING

IN SEVERAL OF THE INSPECTION PROCEDURES DESCRIBED A FULL ALARM WILL BE OBSERVED. THE FULL ALARM CONDITION INCLUDES AN AUDIBLE TONE THAT CAN EXCEED 95 DBA AT 3 METERS (9.9 FT.). TO PREVENT POSSIBLE HEARING DAMAGE DURING TEST, IMMEDIATELY RESET THE ALARM ON VERIFICATION THAT IT IS FUNCTIONING PROPERLY. WEAR HEARING PROTECTION IF PROLONGED EXPOSURE TO A FULL ALARM CONDITION IS ANTICIPATED.

7. To check the pre-alarm, leave respirator motionless for twenty (20) seconds. The green flashing light shall be replaced by a red flashing light. An ascending/descending tone will sound increasing in volume. Leave the respirator motionless.
8. After the pre-alarm condition occurs, check the pre-alarm reset. Within twelve (12) seconds of the pre-alarm, move the respirator to activate the motion sensor. The PAK-TRACKER Locator System specially equipped PAK-ALERT SE 7 distress alarm shall reset to the automatic mode. The red flashing light shall be replaced by a green flashing light and the ascending/descending tone shall stop.
Continue with regular operational inspection of respirator as directed by respirator instructions or your approved respiratory protection plan procedure. During the inspection the respirator must be moved or turned every thirty (30) seconds or less to prevent the sounding of the full alarm.

After completion of all respirator checks and before turning off the cylinder valve:

1. Check the manual reset of the pre-alarm. Leave the respirator motionless until pre-alarm condition occurs. Within twelve (12) seconds press and **hold** the reset button. Three (3) chirps shall sound, then release button. The distress alarm shall reset to the automatic mode and the flashing red light will be replaced by a flashing green light.
2. To check the full alarm, leave the respirator motionless until the pre-alarm condition occurs. Do not reset.
 - a) The full alarm shall sound a loud almost continuous 3 tone chirp accompanied by flashing of the red signal light on the control console.
 - b) The PAK-TRACKER Hand Held Receiver will sound an alarm and display the Identification Number of the PAK-TRACKER Locator System specially equipped PAK-ALERT SE 7 distress alarm which appears on the label on the Sensor Module or the Control Console. Use the SCROLL button on the Hand Held Receiver to highlight the active ID number and press the ENTER button on the Hand Held Receiver to select the displayed ID number. Point the unit directly at and in close proximity to the respirator. The signal strength displayed will be at its highest value.
4. Reset the full alarm by pressing **twice** on the reset button located on the side of the control console (**fully depress reset button, release and press again**).
 - a) The loud alarm shall stop. The unit will sound three chirps and the green light will flash. The unit shall reset to the automatic mode.
 - b) The PAK-TRACKER Hand Held Receiver will reset to its non-alarm state.
5. Finish all respirator checks involving air flow and turn off the cylinder valve. Use the purge valve to release all residual air pressure in the system.

WARNING

IF THE LOW BATTERY INDICATION (ONE STEADY CHIRP EVERY TWO (2) SECONDS WITH NO FLASHING LIGHTS) OCCURS AT ANY TIME DURING REGULAR OPERATIONAL INSPECTION, DO NOT USE THE RESPIRATOR. CHANGE THE BATTERIES IN THE SENSOR MODULE IMMEDIATELY AND REPEAT THE REGULAR OPERATIONAL TEST OR TAKE THE RESPIRATOR OUT OF SERVICE UNTIL THE BATTERIES ARE CHANGED AND THE REGULAR OPERATIONAL TEST IS SUCCESSFULLY PERFORMED.

**REGULAR OPERATIONAL INSPECTION
CONTINUED ON NEXT PAGE...**

REGULAR OPERATIONAL INSPECTION CONTINUED...

With the cylinder valve OFF:

1. Check the continuing operation of the distress alarm. The distress alarm shall remain active with green light flashing. Do not move respirator, pre-alarm shall occur with twenty (20) seconds. Move respirator slightly, pre-alarm shall reset, green light shall start flashing again.
2. To turn the distress alarm off, press the reset button **twice** (press, release and press again). If there is air pressure left in the system, the green flashing light will continue to flash while a fifteen second beep sequence is heard from the sensor module as the residual air bleeds from the system. As soon as the air has completely bled from system, the unit will sound a quick two tone chirp and the PASS DEVICE distress alarm will be inactive. If there is no pressure in the system when the RESET button is pressed twice, there will be no beep sequence. The distress alarm is now in the "OFF" condition. If there is air pressure in the system, the PASS DEVICE distress alarm will return to the active mode.

NOTE

IF THE LOW BATTERY INDICATION (ONE STEADY CHIRP EVERY TWO (2) SECONDS WITH NO FLASHING LIGHTS) OCCURS AT ANY TIME DURING REGULAR OPERATIONAL INSPECTION, DO NOT USE THE RESPIRATOR. CHANGE THE BATTERIES IN THE SENSOR MODULE IMMEDIATELY AND REPEAT THE REGULAR OPERATIONAL TEST OR TAKE THE RESPIRATOR OUT OF SERVICE UNTIL THE BATTERIES ARE CHANGED AND THE REGULAR OPERATIONAL TEST IS SUCCESSFULLY PERFORMED.

OPERATION OF SENSOR MODULE LIGHTS

When performing the REGULAR OPERATIONAL INSPECTION verify that the Sensor Module lights are operating as described below:

ACTION...	SENSOR MODULE LIGHTS WILL...
Start up PASS (Open Cylinder)	Bright Light then Flash GREEN
Normal Operation	Flash GREEN
Respirator Low air (1/4 cylinder)	Flash ORANGE (alternately)
Low Battery while ON	Flash ORANGE once a second
Shut down	Lights OFF
Press RESET w/unit OFF (BATTERY TEST)	Bright Light then: Flash GREEN if Good/Flash RED if Low
Press MANUAL ALARM with unit OFF	Flash GREEN then Full Alarm Flash RED
Press RESET from manual alarm	Returns to Flash GREEN
PASS Pre-Alarm	Flash RED (alternately)
PASS Full alarm	Flash RED (simultaneously)

NOTE

THE ORANGE LIGHT IS A COMBINATION OF THE RED, GREEN, AND WHITE LIGHTS THAT APPEARS ORANGE FROM A DISTANCE. AT CLOSE RANGE THE INDIVIDUAL LIGHTS MAY BE VISIBLE.

SENSOR MODULE LIGHTS ON THE NxG7 SCBA

In addition, when performing the REGULAR OPERATIONAL INSPECTION on NxG7 respirators equipped with a PAK-ALERT SE 7 distress alarm, verify that the Sensor Module lights also operate as described below:

ACTION...	SENSOR MODULE LIGHTS WILL...
Install Cylinder	Flash BLUE
Remove Cylinder	Flash RED

BATTERY REPLACEMENT

Respirators equipped with the PAK-ALERT with the integrated PAK-TRACKER Locator System require six (6) “AA” cell batteries for operation. The six (6) batteries power the Heads-Up Display, the PASS device, and the PAK-TRACKER Transmitter. The batteries should be replaced only by a trained maintenance technician in a clean area known to be nonflammable. Replace batteries as follows:

1. Close respirator cylinder valve, open regulator purge valve letting out all the trapped air, close regulator purge valve, press the reset button twice. If there is air pressure left in the system, the green flashing light will continue to flash while a fifteen second beep sequence is heard from the sensor module as the residual air bleeds from the system. As soon as the air has completely bled from system, the unit will sound a quick two tone chirp and the PASS DEVICE distress alarm will be inactive. If there is no pressure in the system when the RESET button is pressed twice, there will be no beep sequence. If there is air pressure in the system, the PASS DEVICE distress alarm will return to the active mode.

NOTE

ALWAYS BE SURE THAT CYLINDER VALVE IS OFF AND THE PASS DEVICE IS COMPLETELY INACTIVE BEFORE CHANGING BATTERIES. NEVER REMOVE OR REPLACE BATTERIES WITH SYSTEM PRESSURIZED OR DAMAGE MAY OCCUR TO ELECTRONIC COMPONENTS.

2. When replacing batteries on respirators, remove the cylinder and place the respirator in a clean, non-hazardous area.
3. Use a Phillips driver to remove the Battery Housing Cover as shown in FIGURE 6. Carefully remove the cover and set aside.



FIGURE 6

4. Remove used batteries from battery compartment by sliding them out of the battery compartment.
5. Install six (6) fresh new “AA” batteries of the same type. **Always replace all batteries at the same time.**

The battery holder is marked with the style and orientation of the batteries required. See FIGURE 7.

Use six (6) each of one of the following 1.5 volt AA batteries:

- Duracell² Alkaline MN1500
- Duracell Alkaline MX1500
- Duracell Alkaline PC1500
- Eveready Energizer³ Alkaline EN91
- Eveready Energizer Alkaline E91.

Do not mix batteries. Verify correct orientation of batteries as shown on label inside the battery holder.

WARNING

THE PAK-ALERT SE 7 DISTRESS ALARM IS INTENDED TO ASSIST IN LOCATING A PERSON WHO MAY BE IN A LIFE THREATENING SITUATION. FAILURE TO FOLLOW THE INSTRUCTIONS FOR OPENING, CHANGING THE BATTERIES AND RE-CLOSING THE BATTERY COMPARTMENT MAY RESULT IN DAMAGE WHICH COULD CAUSE FAILURE OF THE PASS DURING A LIFE THREATENING EMERGENCY OR COULD CAUSE A FIRE OR EXPLOSION IN A FLAMMABLE OR EXPLOSIVE ATMOSPHERE POSSIBLY RESULTING IN INJURY OR DEATH.

WARNING

BATTERIES MUST ONLY BE CHANGED IN AN AREA KNOWN TO BE NONFLAMMABLE. CHANGING THE BATTERIES IN A FLAMMABLE ATMOSPHERE MAY CAUSE AN IGNITION WHICH COULD RESULT IN SERIOUS INJURY OR DEATH.

CAUTION

SYSTEM MUST NOT BE PRESSURIZED WHEN BATTERIES ARE INSTALLED. DAMAGE TO THE ELECTRONIC COMPONENTS MAY RESULT IF BATTERIES ARE INSTALLED WITH SYSTEM PRESSURIZED.

WARNING

TO REDUCE THE RISK OF EXPLOSION USE BATTERIES ONLY FROM THE LIST PROVIDED, DO NOT MIX OLD BATTERIES WITH UNUSED BATTERIES, AND DO NOT MIX BATTERIES FROM DIFFERENT MANUFACTURERS. UNAUTHORIZED SUBSTITUTION OF COMPONENTS MAY IMPAIR INTRINSIC SAFETY AND CAUSE AN EXPLOSION WHICH COULD LEAD TO SERIOUS INJURY OR DEATH.

² Duracell is a registered trademark of The Gillette Company, Boston, MA.

³ Energizer is a registered trademark of Eveready Battery Company, Inc., St Louis, MO.

6. The battery cover must be installed so that it is water tight after replacement. Clean the sealing rib around battery compartment and sealing face of the cover, shown in FIGURE 7, by wiping with a clean damp cloth to remove any dirt or foreign matter which might prevent a proper seal. Check cover gasket for tears or cuts. If damage is found, remove respirator from service and tag for repair by authorized personnel.



FIGURE 7

7. Install battery cover and tighten the cover screw until snug. AFTER REPLACEMENT OF BATTERIES, PERFORM A REGULAR OPERATIONAL INSPECTION BEFORE RETURNING RESPIRATOR TO SERVICE.

CHECK YOUR WORK!

BEFORE ASSEMBLY OF BATTERY COVER, CHECK TO SEE BOTH BATTERIES ARE FRESH, NEW BATTERIES OF THE TYPE INDICATED ABOVE AND THAT THEY HAVE BEEN INSTALLED PROPERLY.

CLEANING, MAINTENANCE AND STORAGE

Cleaning, maintenance and storage of a respirator with a PAK-TRACKER Locator System specially equipped PAK-ALERT SE 7 distress alarm shall be done as part of the normal respirator CLEANING AND STORAGE and REGULAR OPERATIONAL INSPECTION as described in the OPERATING AND MAINTENANCE INSTRUCTIONS supplied with each SCOTT respirator.

Store the respirator and attached distress alarm in accordance with the OPERATION AND MAINTENANCE INSTRUCTIONS provided with the respirator. Do not store respirators equipped with distress alarms in the proximity of radio antennas or radio transmitter base units. Respirators equipped with PAK-ALERT SE 7 distress alarms must be stored or transported at least two (2) feet away from radio antennas on fire equipment.

Clean the exterior of the PAK-ALERT SE 7 distress alarm while cleaning the exterior of the respirator by wiping with a damp sponge and thoroughly wiping dry. The Signal Light lens on the front of the control console, shown in FIGURE 2, should be cleaned after every use to insure maximum light intensity at all times. Do not use solvents for cleaning or attempt to paint or apply decals to the exterior surfaces of the PAK-ALERT SE 7 distress alarm.

If during use, the respirator and/or PAK-ALERT SE 7 distress alarm is suspected of being contaminated by a hazardous substance, the contaminant must be identified and properly removed or the contaminated component(s) must be replaced before next use. Dispose of the contaminant or the contaminated component(s) in accordance with applicable regulatory requirements.

Except for the replacement of batteries, no attempt shall be made to do maintenance or to make adjustments or repairs beyond the scope of this instruction manual without proper training.

MARKING AND PAINTING

Do not mark, etch, paint, or drill any of the Pak-Alert components or housings in any way.

REPLACEMENT PARTS AND SERVICE

The PAK-ALERT SE 7 distress alarm is covered by a one year warranty.

Consult your Authorized SCOTT Representative, Distributor or Service Center as to the availability of Service and Parts for the PAK-ALERT SE 7 distress alarm. Replacement 9 Volt Batteries of the type designated are commercially available over the counter, from your SCOTT Distributor, and from most Industrial Battery Distributors.

Except for the replacement of batteries, no attempt shall be made to do maintenance or to make adjustments or repairs beyond the scope of this instruction manual without proper training.

RETIREMENT CRITERIA AND CONSIDERATION

Retirement criteria and consideration shall be determined by SCOTT trained and Certified Overhaul Technicians.

WARNING

READ AND UNDERSTAND THE COMPLETE INSTRUCTION MANUAL BEFORE USING A RESPIRATOR WITH A PAK-ALERT SE 7 DISTRESS ALARM INSTALLED.

QUICK REFERENCE GUIDE TO USE:

WHEN YOU WANT TO:	YOU DO:	THE PAK-ALERT SE 7 DISTRESS ALARM DOES:
Turn it on.	Open cylinder valve (cylinder <u>must</u> have air in it).	3 quick audible chirps, green flashing light on control console.
Re-set pre-alarm	Move so that the respirator moves.	Red flashing light changes to green, ascending/descending tone stops.
Re-set full alarm	Press re-set button on control console twice (push, release, push again).	Loud 3 tone chirp stops, 3 quick chirps, then red flashing light changes to green flashing light.
Turn it off (finished with use)	Close respirator cylinder valve, open regulator purge valve letting out all the trapped air, close regulator purge valve, press re-set button twice.	The flashing light goes out and a fifteen (15) second beep sequence occurs as the residual air bleeds off. Unit will sound a two tone chirp at turn off.
Turn on the manual alarm.	Press alarm button on control console (works whether the PAK-ALERT SE 7 distress alarm is on or off).	Goes into full alarm, loud 3 tone chirps from sensor module and bright <u>red</u> flashing light from control console.

WHEN THE PAK-ALERT DISTRESS ALARM IS:	IT INDICATES THAT:
Quiet. No lights or sound	The PAK-ALERT SE 7 distress alarm is off or the batteries are used up or removed.
Flashing the green light	The PAK-ALERT SE 7 distress alarm is on, in automatic mode, and monitoring your motion.
Flashing the red light and sounding an ascending/descending tone.	You have not moved in the last twenty (20) seconds, PAK-ALERT SE 7 distress alarm will go into full alarm in twelve (12) seconds or less if you do not move.
Flashing the red light and sounding a loud continuous 3 tone chirp	Full alarm: You have not moved in the last thirty (30) seconds or more or you pushed the manual alarm button.
Chirping once every two (2) seconds with no light flashing	The batteries are low. You must put in new batteries before using the PAK-ALERT SE 7 distress alarm again (it will work in low battery condition long enough to let you finish the cylinder of air you are on).

PAK-ALERT SE 7 DISTRESS ALARM PERFORMANCE SPECIFICATIONS

Sound Levels:

- Pre-Alarm..... 70 to 105 dBA incrementally at left ear
- Full-Alarm 95 to 100 dBA @ 9.9 Ft. (3m)
- Frequency Range 1.5 KHz to 4 KHz

Battery Life (fresh batteries)

Alkaline Batteries:

- Automatic (green flashing light, no sound) Approx. 1000 hours
- Full Alarm (red flashing light, 95 dBA sound)..... Approx. 8 hours

Lithium Batteries:

- Automatic (green flashing light, no sound)..... > 2,000 hours
- Full alarm (red flashing light, 95 dBA sound) 8-16 hours

Compliance

The SCOTT PAK-ALERT SE 7 distress alarm is a NIOSH approved accessory for use on only the following SCOTT AIR-PAK respirators: (NIOSH approval numbers have been included for identification):

SCOTT 2.2 Air-Pak (30 min.)	TC-13F-80
SCOTT 3.0 Air-Pak (30 min.)	TC-13F-366
SCOTT 4.5 Air-Pak (30 min.)	TC-13F-76
SCOTT 4.5 Air-Pak (45 min.)	TC-13F-212
SCOTT 4.5 Air-Pak (60 min.)	TC-13F-96

NOTE

DO NOT USE A FIBERGLASS WRAPPED ONE HOUR CYLINDER ON A MODEL 4.5 AIR PAK EQUIPPED WITH A PAK-ALERT SE 7 DISTRESS ALARM AS THE WEIGHT WILL EXCEED THE 35 LBS APPROVAL LIMIT FOR SCBA's ESTABLISHED BY NIOSH.

QUESTIONS OR CONCERNS

If you have any questions or concerns regarding use of this equipment, contact your authorized SCOTT dealer or distributor, or contact SCOTT at 1-800-247-7257 (or 704-291-8300 outside the continental United States) or visit our web site at www.scotthealthsafety.com.

Report any operational malfunctions of the PASS function of this device to the certification agency Safety Equipment Institute (SEI), 1307 Dolley Madison Blvd. Suite 3A, McLean, VA 22101, (703) 442-5732, FAX (703) 442-5756.

**NOTICE:
THESE USER INSTRUCTIONS
ARE TO BE REMOVED ONLY
BY THE END USER.**



Scott
Health & Safety
ISO 9001 REGISTERED

tyco

SCOTT
HEALTH & SAFETY

Health & Safety Products
Monroe Corporate Center
PO Box 569
Monroe, NC 28111
Telephone 1-800-247-7257
FAX (704) 291-8330
www.scotthealthsafety.com

Printed in USA