



Instructions and Parts List

3M-Matic™

700r3 Type 39600

Random

Case Sealer

with

AccuGlide™ 2+

Taping Heads

Serial No. _____
For reference, record machine serial number here.



3M Industrial Adhesives and Tapes

3M Center, Building 220-5E-06
St. Paul, MN 55144-1000



Important Safety Information

BEFORE INSTALLING OR
OPERATING THIS
EQUIPMENT

Read, understand, and follow
all safety and operating
instructions.

Spare Parts

It is recommended you
immediately order the spare
parts listed in the "Spare
Parts/Service Information"
section. These parts are
expected to wear through
normal use, and should be
kept on hand to minimize
production delays.

"3M-Matic" and "AccuGlide" are Trademarks
of 3M, St. Paul, MN 55144-1000

Printed in U.S.A.

©3M2005 44-0009-2058-5 (A)

To Our Customers:

This is the 3M-Matic™/AccuGlide™/Scotch® equipment you ordered. It has been set up and tested in the factory with Scotch® tapes. If technical assistance or replacement parts are needed, call or fax the appropriate number listed below.

Included with each machine is an Instructions and Parts List manual.

Technical Assistance:

3M-Matic™ Helpline – 1-800/328 1390. Please provide the customer support coordinator with the machine number, machine type/model and serial number. If you have a technical question that does not require an immediate response, you may Fax it to 651-736-7282.

Replacement Parts and Additional Manuals

Order parts by part number, part description and quantity required. Also, when ordering parts and/or additional manuals, include machine name, number and type. A parts order form is provided at the back of this manual.

3M/Tape Dispenser Parts

241 Venture Drive

Amery, WI 54001-1325

1-800/344 9883

FAX# 715/268 8153

Minimum billing on parts orders will be \$25.00. Replacement part prices available on request.

\$10.00 restocking charge per invoice on returned parts.

Note : Outside the U.S., contact the local 3M subsidiary for parts ordering information.



3M Industrial Adhesives and Tapes

3M Center, Building 220-5E-06
St. Paul, MN 55144-1000

"3M-Matic", "AccuGlide" and "Scotch" are trademarks of 3M, St. Paul, Minnesota 55144-1000

Printed in U.S.A.

© 3M 2005 44-0009-1851-4(F)

To Our Customers:

This is the 3M-Matic™/AccuGlide™/Scotch® equipment you ordered. It has been set up and tested in the factory with Scotch® tapes. If any problems occur when operating this equipment and you desire a service call or phone consultation, call, write or fax the appropriate number listed below.

Included with each machine is an Instructions and Parts List manual.

**SERVICE, REPLACEMENT PARTS AND ADDITIONAL MANUALS
AVAILABLE DIRECT FROM:**

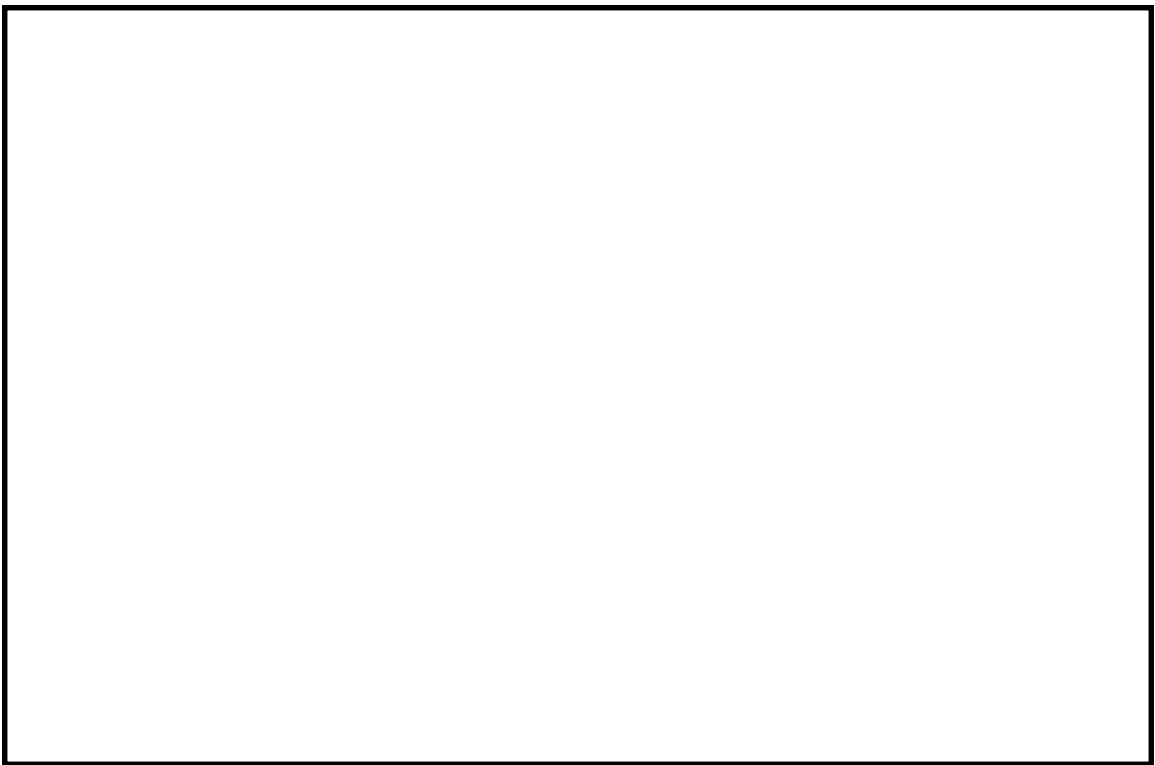

Order parts by part number, part description and quantity required. Also, when ordering parts and/or additional manuals, include machine name, number and type.



3M Industrial Adhesives and Tapes
3M Center, Building 220-5E-06
St. Paul, MN 55144-1000

"3M-Matic", "AccuGlide" and "Scotch" are trademarks of 3M, St. Paul, Minnesota 55144-1000

Printed in U.S.A.

© 3M 2005 44-0009-1852-2(E)

Instruction Manual

700r3, Random Case Sealer, Type 36900

This instruction manual is divided into two sections as follows:

- Section I** Includes all information related to installation, operation and parts for the case sealer.
- Section II** Includes specific information regarding the AccuGlide™ 2+ STD 3 Inch Taping Heads.

Table of Contents

Page

Section I – 700r3 Random Case Sealer

Intended Use	1
Equipment Warranty and Limited Remedy	2
700r3 Contents	2
Important Safeguards	3 - 7
Specifications	8 - 10
Installation and Set-Up	11 - 15
Receiving and Handling	11
Machine Set-Up	11 - 14
Packaging and Separate Parts	11 - 12
Infeed Conveyor Assembly	13
Centering Guides	13
Machine Bed Height	14
Outboard Tape Roll Mounting	14
Tape Leg Length	14
Bumper Supports	15
Box Size Capacity of Case Sealer	15
Electrical Connection and Controls	15
Initial Start-Up of Case Sealer	15
Operation	16 - 21
Operating "Warnings"	19
Machine Switches and Controls	17 - 18
Tape Loading/Threading	20
Theory of Operation	20 - 21
Box Sealing	21

(Table of Contents continued on next page)

Table of Contents (Continued)	Page
Maintenance	22 - 24
Cleaning	22
Lubrication	22
Box Drive Belt Replacement	23
Circuit Breaker	24
Knife Replacement, Taping Head	24
Adjustments	25 - 27
Box Drive Belt Tension	25 - 27
Taping Head Adjustments	27
Special Set-Up Procedure	28 - 31
Changing Tape Leg Length	28 - 29
Box and Machine Bed Height Range	30
Box Height Range	31
Troubleshooting	32 - 33
Electrical Diagram	34
Pneumatic Diagram	35
Replacement Parts and Service Information	36
Spare Parts	36
Label Kit	36
Tool Kit	36
Options/Accessories	37
Replacement Parts Illustrations and Parts Lists (Yellow Section)	38 - 64

Section II – AccuGlide™ 2+ STD 3 Inch Taping Heads

(See Section II for Table of Contents)

Intended Use

The **3M-Matic™ 700r3 Random Case Sealer with AccuGlide™ 2+ Taping Heads** is designed to apply a “C” clip of **Scotch®** pressure-sensitive film box sealing tape to the top and bottom center seam of regular slotted containers. The 700r3 automatically adjusts to a wide range of box sizes (see "Specifications Section – Box Weight and Size Capacities").

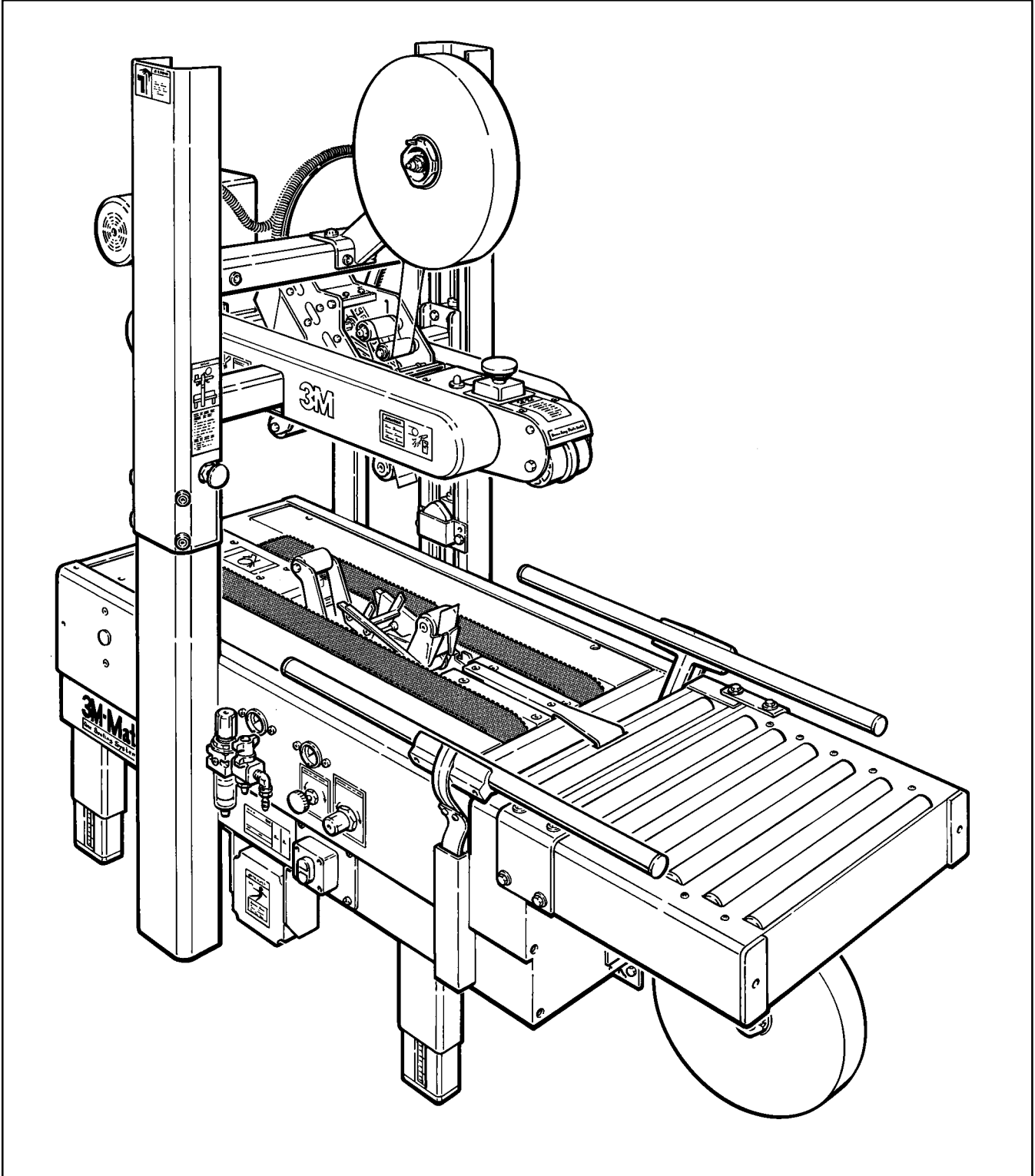

3M-Matic™ 700r3 Random Case Sealer, Type 39600 (Note – Lower tape supply roll and bracket assembly are shown in the alternate location)

Equipment Warranty and Limited Remedy: THE FOLLOWING WARRANTY IS MADE IN LIEU OF ALL OTHER WARRANTIES, EXPRESS OR IMPLIED, INCLUDING, BUT NOT LIMITED TO, ANY IMPLIED WARRANTY OF MERCHANTABILITY OR FITNESS FOR A PARTICULAR PURPOSE AND ANY IMPLIED WARRANTY ARISING OUT OF A COURSE OF DEALING, CUSTOM OR USAGE OF TRADE:

3M sells its **3M-Matic™ 700r3 Adjustable Case Sealer, Type 39600** with the following warranties:

1. The drive belts and the taping head knives, springs and rollers will be free from defects in material and manufacture for ninety (90) days after delivery.
2. All other taping head parts will be free from defects in material and manufacture for three (3) years after delivery.
3. All other parts will be free from defects in material and manufacture for two (2) years after delivery.

If any part is defective within this warranty period, your exclusive remedy and 3M's and seller's sole obligation shall be, at 3M's option, to repair or replace the part. 3M must receive actual notice of any alleged defect within a reasonable time after it is discovered, but in no event shall 3M have any obligation under this warranty unless it receives such notice within five (5) business days after the expiration of the warranty period. All notices required hereunder shall be given to 3M solely through the 3M-Matic™ Helpline (800-328-1390). To be entitled to repair or replacement as provided under this warranty, the part must be returned as directed by 3M to its factory or other authorized service station designated by 3M. If 3M is unable to repair or replace the part within a reasonable time after receipt thereof, 3M, at its option, will replace the equipment or refund the purchase price. 3M shall have no obligation to provide or pay for the labor required to remove any part or equipment or to install the repaired or replacement part or equipment. 3M shall have no obligation to repair or replace those parts failing due to normal wear, inadequate or improper maintenance, inadequate cleaning, non-lubrication, improper operating environment, improper utilities, operator error or misuse, alteration or modification, mishandling, lack of reasonable care, or due to any accidental cause.

Limitation of Liability: Except where prohibited by law, 3M and seller will not be liable for any loss or damage arising from this 3M equipment, whether direct, indirect, special, incidental, or consequential, regardless of the legal theory asserted, including breach of warranty, breach of contract, negligence, or strict liability.

Note: The foregoing Equipment Warranty and Limited Remedy and Limitation of Liability may be changed only by a written agreement signed by authorized representatives of 3M and seller.

Contents – 700r Random Case Sealer

- (1) 700r3 Random Case Sealer, Type 39600
- (1) Upper Tape Drum/Bracket/Hardware
- (2) Column Bumper Bracket/Hardware
- (1) Tool/Spare Parts Kit
- (1) Instruction and Parts Manual

Important Safeguards

 This safety alert symbol identifies important messages in this manual. **READ AND UNDERSTAND THEM BEFORE INSTALLING OR OPERATING THIS EQUIPMENT.**

Explanation of Signal Word Consequences

 **WARNING:** Indicates a potentially hazardous situation, which, if not avoided, could result in death or serious injury and/or property damage.

 **CAUTION:** Indicates a potentially hazardous situation, which, if not avoided, may result in minor or moderate injury and/or property damage.

WARNING

- **To reduce the risk associated with mechanical and electrical hazards:**
 - Read, understand and follow all safety and operating instructions before operating or servicing the case sealer
 - Allow only properly trained and qualified personnel to operate and/or service this equipment
 - Turn electrical and air supply off and disconnect before performing any adjustments, maintenance or servicing the machine or taping heads
- **To reduce the risk associated with pinch and entanglement hazards:**
 - Do not leave the machine running while unattended
 - Turn the machine off while not in use
 - Never attempt to work on any part of the machine, load tape, or remove jammed boxes from the machine while the machine is running
- **To reduce the risk associated with hazardous voltage:**
 - Position electrical cord away from foot and/or vehicle traffic

WARNING (continued)

- **To reduce the risk associated with impact hazards:**
 - Always use appropriate supporting means when working under the upper drive assembly
- **To reduce the risk associated with sharp blade hazards:**
 - Keep hands and fingers away from tape cutoff blades under orange blade guards. The blades are extremely sharp
- **To reduce the risk associated with fire and explosion hazards:**
 - Do not operate this equipment in potentially flammable/explosive environments
- **To reduce the risk associated with muscle strain:**
 - Use the appropriate rigging and material handling equipment when lifting or repositioning this equipment
 - Use proper body mechanics when removing or installing taping heads that are moderately heavy or may be considered awkward to lift

CAUTION

- **To reduce the risk associated with pinch and entanglement hazards:**
 - Keep hands clear of the upper head support assembly as boxes are transported through the machine
 - Always feed boxes into the machine by pushing only from the end of the box
 - Keep hands, hair, loose clothing, and jewelry away from moving belts and taping heads
- **To reduce the risk associated with pinch and impact hazards:**
 - Keep away from the pneumatically controlled upper drive assembly and box centering guides when air and electric supplies are on

Important Safeguards (Continued)

Important – In the event the following safety labels are damaged or destroyed, **they must be replaced to ensure operator safety**. Replacement part numbers for individual labels are shown in Figures 1-1 through 1-3, or a label kit, part number 78-8098-9177-9, is available that includes all labels used on the machine. See "Safety and Information Labels," end of Parts Illustration/List, Section I.

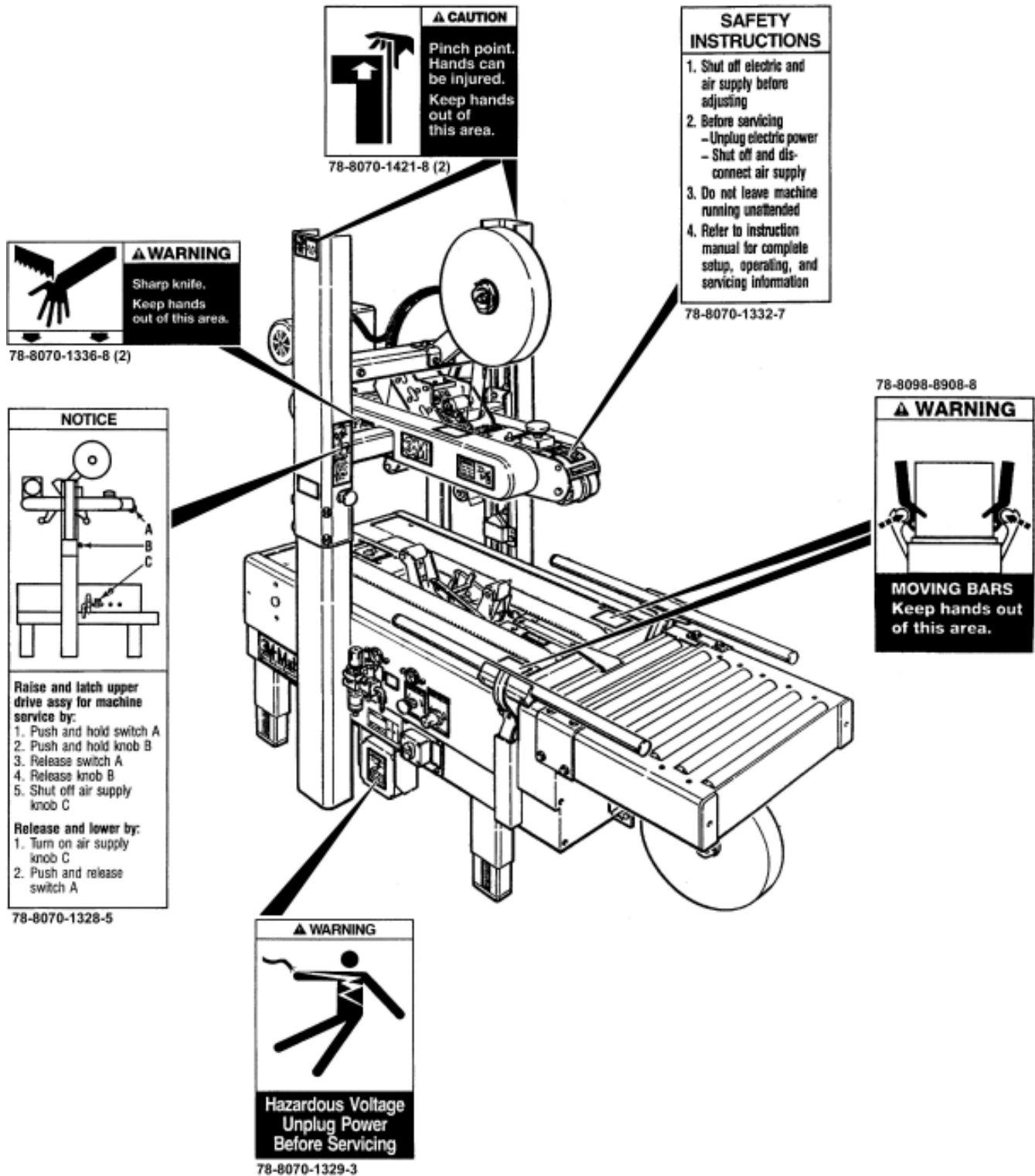

Figure 1-1 – Replacement Labels/3M Part Numbers

Important Safeguards (Continued)

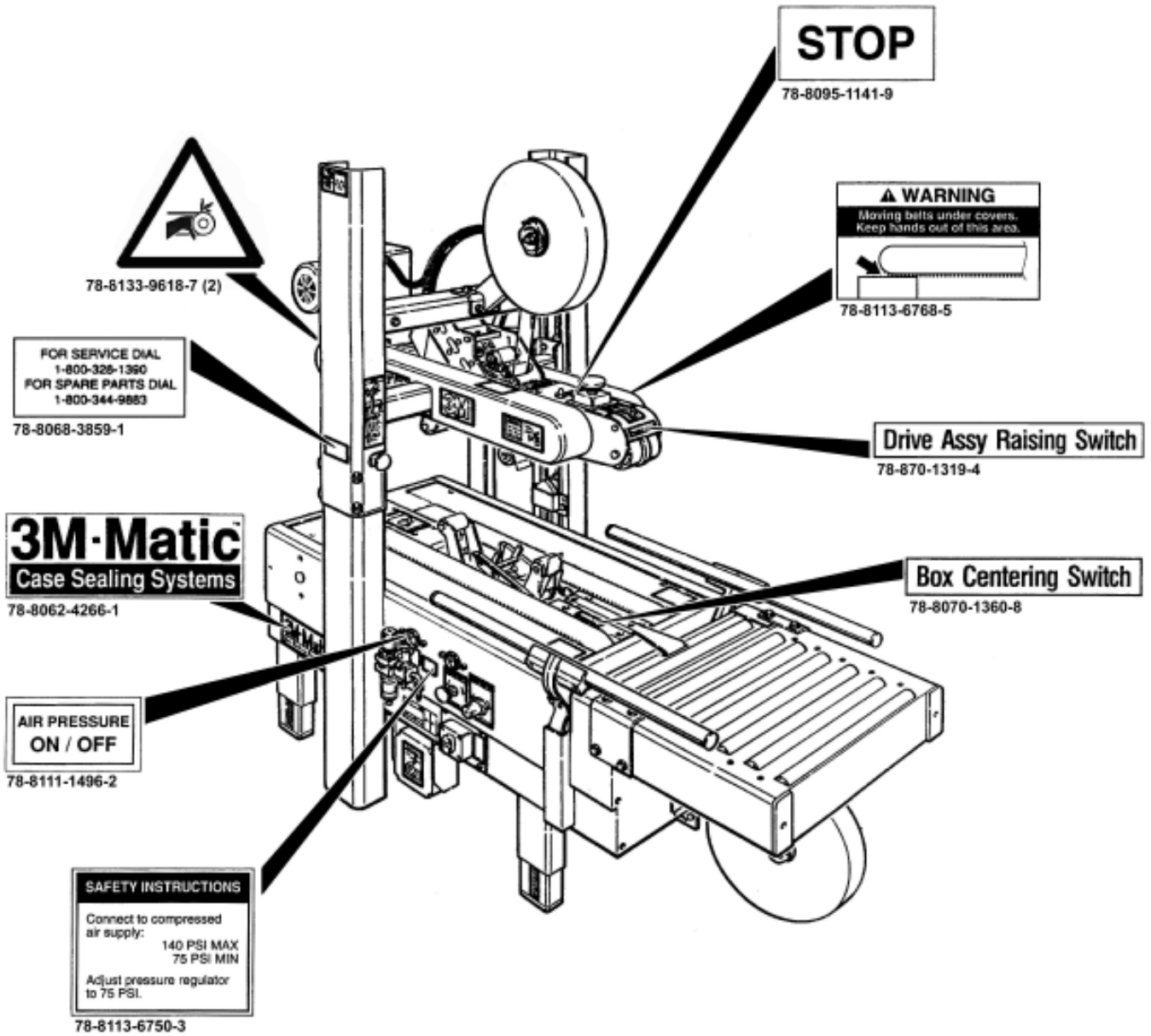

Figure 1-2 – Replacement Labels/3M Part Numbers

Important Safeguards (Continued)

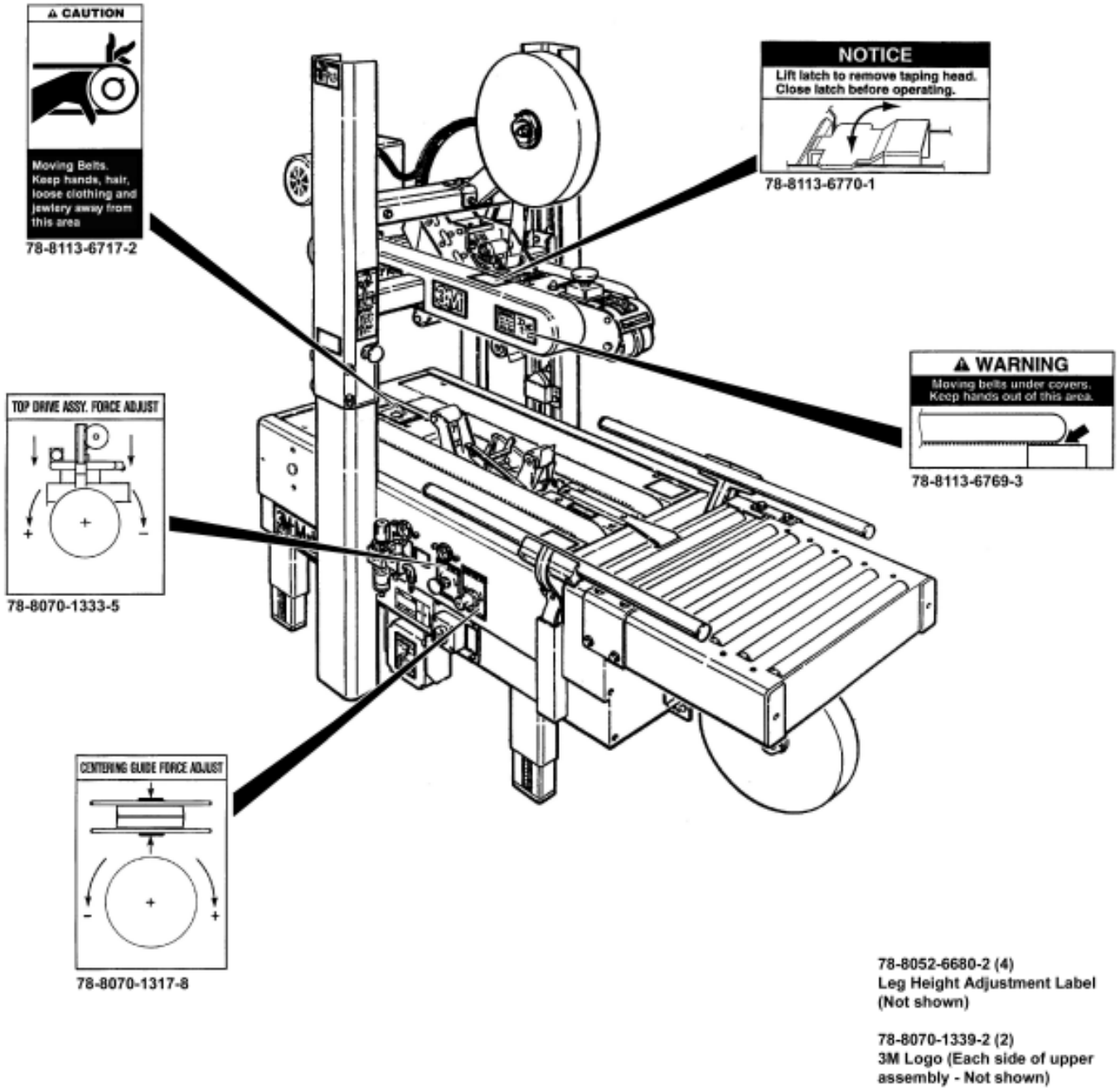

Figure 1-3 – Replacement Labels/3M Part Numbers

Important Safeguards (Continued)



WARNING

- **To reduce the risk associated with mechanical and electrical hazards:**
 - Allow only properly trained and qualified personnel to operate and/or service this equipment

Operator Skill Level Descriptions

Skill 1 - Machine Operator

This operator is trained to use the machine with the machine controls, to feed cases into the machine, make adjustments for different case sizes, to change the tape and to start, stop and restart production.

Important – the factory manager must ensure that the operator has been properly trained on all the machine functions before starting work.

Skill 2 - Mechanical Maintenance Technician

This operator is trained to use the machine as the MACHINE OPERATOR and in addition is able to work with the safety protection disconnected, to check and adjust mechanical parts, to carry out maintenance operations and repair the machine. He is not qualified to work on live electrical components.

Skill 2a - Electrical Maintenance Technician

This operator is trained to use the machine as the MACHINE OPERATOR and in addition is able to work with the safety protection disconnected, to make adjustments, to carry out maintenance operations and repair the electrical components of the machine. He is qualified to work on live electrical panels, connector blocks, control equipment, etc.

Skill 3 - Specialist From the Manufacturer

Skilled operator sent by the manufacturer or its agent to perform complex repairs or modifications, when agreed with the customer.

Operator's Skill Levels Required to Perform the Main Operations on Machine

Operation	State of the Machine	Operator's Skill	Number of Operators
Installation and set up of the machine.	Running with safety protections disabled.	2 and 2a	2
Adjustment of the box size.	Stopped by pressing the STOP button.	1	1
Tape replacement.	Stopped by pressing the STOP button.	1	1
Replacement of blades.	Electric power disconnected.	2	1
Replacement of drive belts.	Electric power disconnected.	2	1
Ordinary maintenance.	Electric power disconnected.	2	1
Extraordinary maintenance (mechanical).	Running with safety protections disabled.	3	1
Extraordinary maintenance (electrical).	Running with safety protections disabled.	2a	1

Specifications

1. Power Requirements:

Electrical – 115 VAC, 60 Hz, 3.8 A (440 watts)

Pneumatic – 5 bar gauge pressure [70 PSIG]

110 litre/min @ 21° C, 1.01 bar [3.75 SCFM] at 15 boxes per minute

A pressure regulator is included

The machine is equipped with two 1/6 HP gearmotors and comes with an 2.4 m [eight foot] standard neoprene covered power cord and a grounded plug. Contact your 3M Representative for power requirements not listed above.

2. Operating Rate:

Up to 15 boxes per minute. Actual production rate is dependent on box size, box size mix, and operator dexterity.

Box drive belt speed approximately 0.4 m/s [78 FPM]

3. Operating Conditions:

Use in dry, relatively clean environments at 4° to 50° C [40° to 120° F] with clean, dry, boxes.

Note: Machine should not be washed down or subjected to conditions causing moisture condensation on components.



WARNING

- **To reduce the risk associated with fire and explosion hazards:**

- Do not operate this equipment in potentially flammable/explosive environments

4. Tape:

Scotch[®] pressure-sensitive film box sealing tapes.

5. Tape Width:

50 mm or 2 inch minimum to 75 mm [3 inch] maximum

6. Tape Roll Diameter:

Up to 405 mm [16 inch] maximum on a 76.2 mm [3 inch] diameter core.

(Accommodates all system roll lengths of **Scotch**[®] film tapes.)

7. Tape Application Leg Length – Standard:

70 mm ± 6 mm [2 3/4 inch ±1/4 inch]

Tape Application Leg Length – Optional:

(See "Special Set-Up Procedure")

50 mm ± 6 mm [2 inch ±1/4 inch]

(Specifications continued on next page)

Specifications (Continued)

8. Box Board:

Style – regular slotted containers – RSC
125 to 275 P.S.I. bursting test, single wall or double wall B or C flute.

9. Box Weight and Size Capacities:

A. Box Weight, up to 38.6 kg [85 lbs.] **maximum** – contents must support flaps.

B. Box Size:	Minimum	Maximum
Length –	150 mm [6.0 inch]	Unlimited
Width –	150 mm [7.0 inch]*	550 mm [21.5 inch]
Height –	120 mm [4.75 inch]** ***	620 mm [24.5 inch] ***

* Cartons narrower than 275 mm [11 inch] in width may require more frequent belt replacement because of limited contact area.

** 95 mm [3.75 inch] height with heads adjusted to apply 50 mm [2 inch] tape leg lengths. (See "Special Set-Up Procedure".)

*** 200 mm [8.0 inch] minimum to 725 mm [28.5 inch] maximum height with columns adjusted to upper position. (See "Special Set-Up Procedure".)

**Special modifications may be available for carton sizes not listed above.
Contact your 3M Representative for information.**

Note: The case sealer can accommodate most boxes within the size range listed above. However, if the box length (in direction of seal) to box height ratio is .5 or less, then several boxes should be test run to assure the proper machine performance.

DETERMINE THE BOX LIMITATIONS BY COMPLETING THIS FORMULA:

$$\frac{\text{BOX LENGTH IN DIRECTION OF SEAL}}{\text{BOX HEIGHT}} = \text{SHOULD BE GREATER THAN .5}$$

Any box ratio approaching this limitation should be test run to assure performance.

Specifications (Continued)

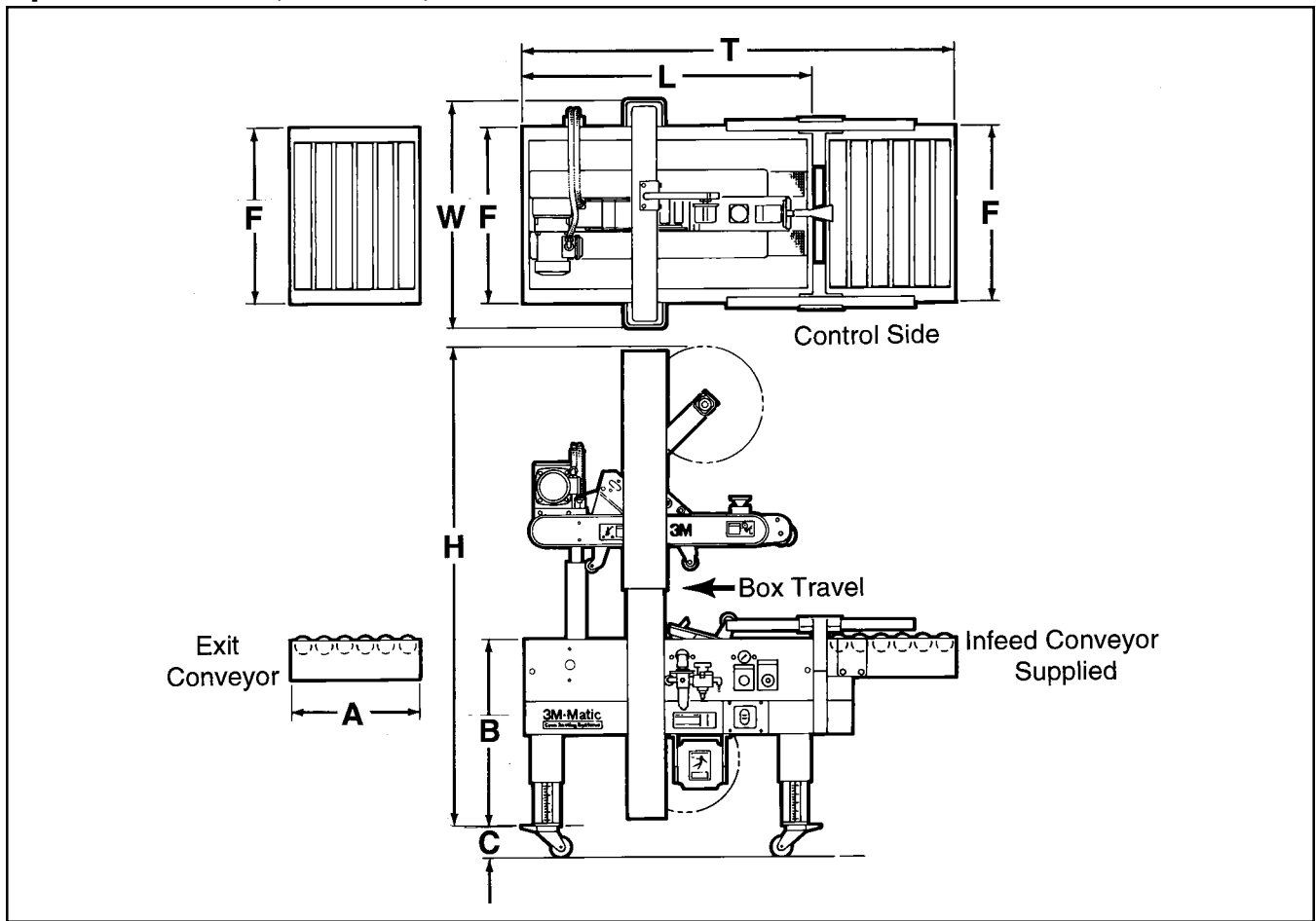

10. Machine Dimensions:

	W	L	H	A*	B	C**	F	T
Minimum								
mm	790	1180	1575	460	610***	120	625	1640
[Inches]	[31]	[40.5]	[62]	[18]	[24]	[4.75]	[24.5]	[64.5]
Maximum								
mm	--	--	2185***	--	890	--	--	--
[Inches]	--	--	[86]	--	[35]	--	--	--

* Exit conveyor is optional

** Casters are optional

*** When columns are adjusted to upper position, "B" minimum dimension is 570 mm [22.5 inch] and "H" maximum dimension is 2285 mm [90 inch]. (See "Special Set-Up Procedure – Box and Machine Bed Height Range".)

Weight – 225 kg [500 lbs] crated (approximate)
200 kg [430 lbs] uncrated (approximate)

11. Set-Up Recommendations:

- Machine must be level.
- Customer supplied infeed and exit conveyors (if used) should provide straight and level box entry and exit.
- Exit conveyors (powered or gravity) must convey sealed boxes away from machine.

Installation and Set-Up

Receiving And Handling

After the machine has been uncrated, examine the case sealer for damage that might have occurred during transit. **If damage is evident, file a damage claim immediately** with the transportation company and also notify your 3M Representative.

Machine Set-Up

WARNING

- **To reduce the risk associated with mechanical and electrical hazards:**
 - Read, understand and follow all safety and operating instructions before operating or servicing the case sealer

The following instructions are presented in **the order recommended** for setting up and installing the case sealer, as well as **for learning the operating functions and adjustments**. Following them step by step will result in your thorough understanding of the machine and an installation in your production line that best utilizes the many features built into the case sealer. Refer to Figure 3-1 to identify the various components of the case sealer.

Note – A tool kit consisting of metric open end and hex socket wrenches is provided with the machine. These tools should be adequate to set-up the machine, however, other tools supplied by the customer will be required for machine maintenance.

PACKAGING AND SEPARATE PARTS

1. Lift off fiberboard cover from pallet after removing staples and straps at bottom.
2. Remove protective wrapping around machine.
3. Install the upper tape drum bracket on the top crossbar as shown in Figure 2-1A.
4. The column guards, shown in Figure 2-1 have been installed upside down for shipping. They must be repositioned for safe operation of the machine. Remove and retain the screws and washers holding the guards on the columns. Rotate the guards 180° and install back on the columns as shown. Replace existing screws and washers to secure the guards in place.
5. Cut cable ties securing upper assembly to machine bed on each side.

6. Pneumatic connection.

Important – Use care when working with compressed air.

The case sealer requires a 5 bar gauge pressure 110 litre/min [70 PSIG], @21°C, 1.01 bar [3.75 SCFM] compressed air supply. As shown in Figure 3-1, an on/off valve, pressure regulator, and filter are provided to service the air supply.

Note – A precision regulator is used to balance the top drive assembly. Due to the self relieving feature of this regulator a small amount of air will continually vent to the atmosphere. This is normal and amounts to approximately 3 litre/min. [0.1 SCFM].

- a. Read and remove safety tag from pneumatic "On/Off" valve.
- b. Connect the main air supply line to the inlet side of the on/off valve using the barbed fitting and hose clamp provided. See Figure 2-1B. The customer supplied air hose (8 mm [5/16 inch] ID) must be clamped tightly to the barbed fitting.

If another type of connector is desired, the barbed fitting can be removed and replaced with the desired 1/4-18 NPT threaded connector.

Always turn the air valve "Off" when the air supply line is being connected or disconnected.

7. Turn the air supply on by turning the air on/off valve to SUP (On).

Note – The air valve has provisions for lock out/tag out according to plant regulations.

WARNING

- **To reduce the risk associated with impact hazards:**
 - Always use appropriate supporting means when working under the upper drive assembly

8. Raise and latch upper drive assembly in full "Up" position.

Note – Read "Operation – Mechanical Latch" before raising and latching upper drive assembly.

Installation and Set-Up (Continued)

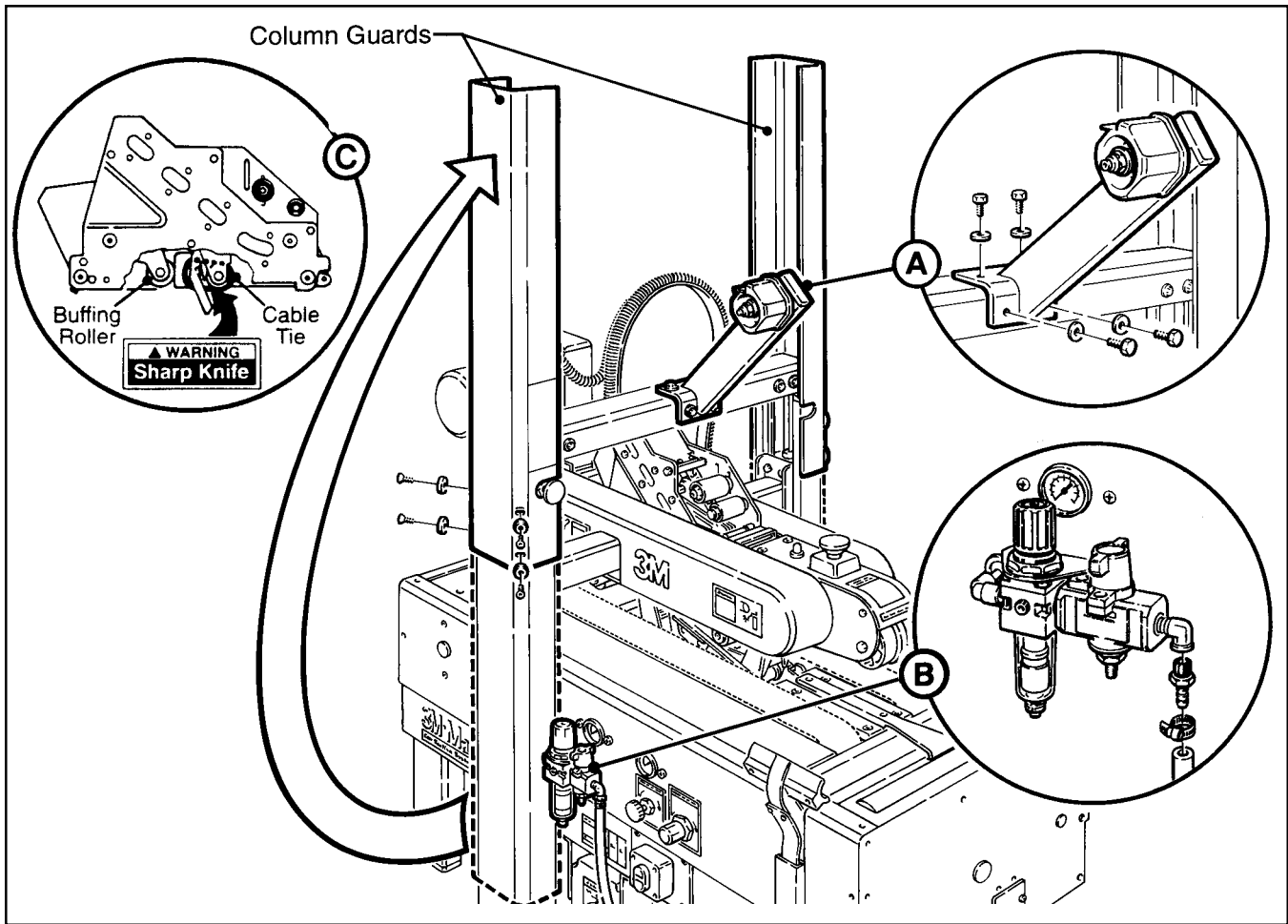

Figure 2-1 – 700r3 Frame Set-Up

9. Cut and remove cable ties on both upper and lower taping heads. (Applying/buffing rollers are held retracted for shipment.)

WARNING

- **To reduce the risk associated with sharp blade hazards:**
 - Keep hands and fingers away from tape cutoff blades under orange blade guards. The blades are extremely sharp

Hold taping head BUFFING ROLLER and cut and remove cable tie that holds applying/buffing arms retracted. See Figure 2-1C. Allow buffing/applying arms to extend slowly.

Also cut and remove cable tie at rear of lower taping head.

10. Check for free action of both upper and lower taping heads.

WARNING

- **To reduce the risk associated with sharp blade hazards:**
 - Keep hands and fingers away from tape cutoff blades under orange blade guards. The blades are extremely sharp

Push buffing roller into head to check for free, smooth action of taping heads.

11. Ensure that the tape drum bracket assembly, located on the lower taping head, is mounted straight down, as shown in Figure 2-5A. The tape drum bracket assembly can be pivoted to provide tape roll clearance in certain cases.
12. Remove fasteners that secure case sealer legs to pallet.

Installation and Set-Up (Continued)

13. Use appropriate material handling equipment to remove the machine from the pallet and move it into position.

Whenever the machine is lifted with a fork truck, insure that the forks span completely across the machine frame and do not contact any wiring or mechanism under the machine frame. In some cases the lower taping head may need to be removed to avoid damage.

WARNING

- **To reduce the risk associated with muscle strain:**
 - Use the appropriate rigging and material handling equipment when lifting or repositioning this equipment

14. Continue with the remainder of the Installation and Set-Up procedure section.

INFEED CONVEYOR ASSEMBLY

1. Remove the conveyor and the package of parts from the carton.
2. Verify that the package contains two right angled cover plates, twelve M8 x 15 hex head screws, and eight M8 flat washers.
3. To assemble the infeed conveyor, refer to Figure 2-2 and locate four bolt holes on the infeed end of the case sealer frame.
4. Insert a M8 x 15 screw in each hole so that only a few threads take hold. Do not use washers with these screws.
5. Attach the infeed conveyor over the screws using the inverted keyholes in the end of the conveyor. Tighten all four screws with a 13 mm wrench.
6. Refer to Figure 2-3. Set the cover plates over the joint between the conveyor and the frame on each side and secure them with four M8 x 15 screws and M8 washers.

CENTERING GUIDES

1. Remove the two centering guides and four M6 x 20 socket head screws from the package.
2. Using a 5 mm hex key wrench, attach the centering guides to the rails with four M6 x 20 screws (two in each guide) as shown in Figure 2-4.

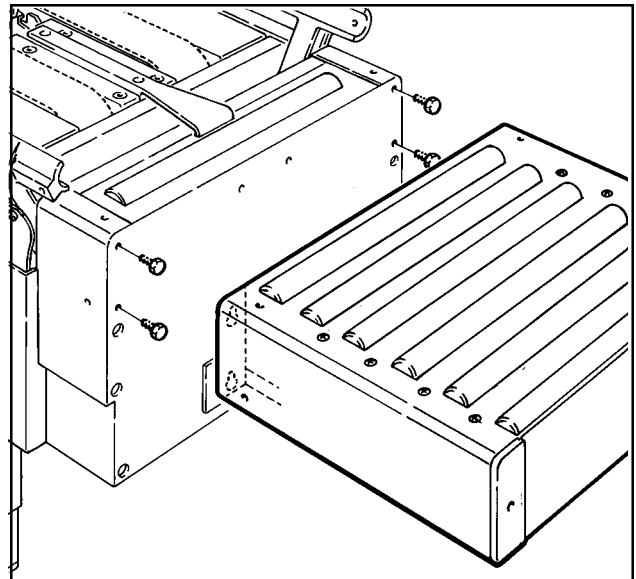

Figure 2-2 – Infeed Conveyor

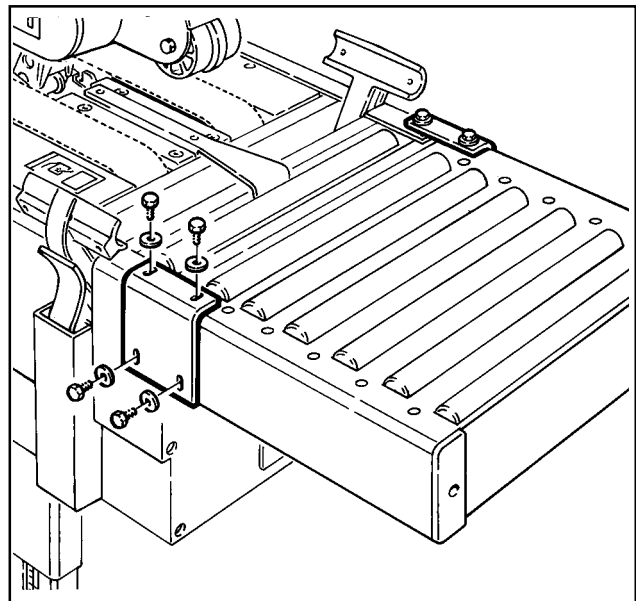

Figure 2-3 – Cover Plates

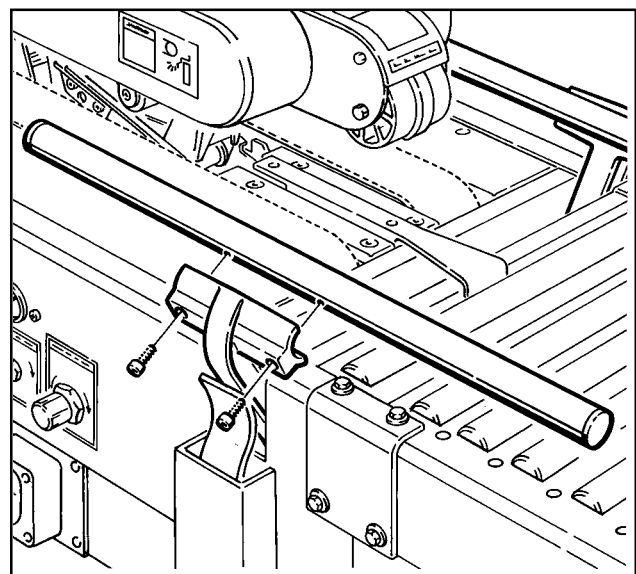

Figure 2-4 – Centering Guides

Installation and Set-Up (Continued)

MACHINE BED HEIGHT

Adjust machine bed height. The case sealer is equipped with four adjustable legs that are located at the corners of the machine frame. The legs can be adjusted to obtain different machine bed heights from 610 mm [24 inch] minimum to 890 mm [35 inch] maximum.

Note – Minimum machine bed height can be reduced to 570 mm [22.5 inch] by moving outer columns up one set of mounting holes. However, this change also increases minimum box height of 120 mm [4.8 inch] to 170 mm [6.8 inch]. (See "Special Set-Up Procedure – Box/Machine Bed Height Range.")

Refer to Figure 2-5C and set the machine bed height as follows:

1. Use appropriate material handling equipment and blocking techniques to raise the machine frame to allow adequate leg adjustment.
2. Loosen, but do not remove, two M8 x 1.25 socket head screws in one leg (use M6 hex wrench). Adjust the leg length for the desired machine bed height. Retighten the two screws to secure the leg. Adjust all four legs equally.

OUTBOARD TAPE ROLL MOUNTING (Lower Taping Head)

Remove the tape drum bracket assembly, spacer and fasteners from the lower taping head. Install and secure on the infeed end of the lower frame, as shown in Figure 2-5B.

TAPE LEG LENGTH

Taping heads are pre-set to apply 70 mm [2.75 inch] long tape legs. To change tape leg length to 50 mm [2.0 inch], see "Special Set-Up Procedure – Changing the Tape Leg Length."

**WARNING**

- **To reduce the risk associated with muscle strain:**
 - Use the appropriate rigging and material handling equipment when lifting or repositioning this equipment
 - Use proper body mechanics when removing or installing taping heads that are moderately heavy or may be considered awkward to lift

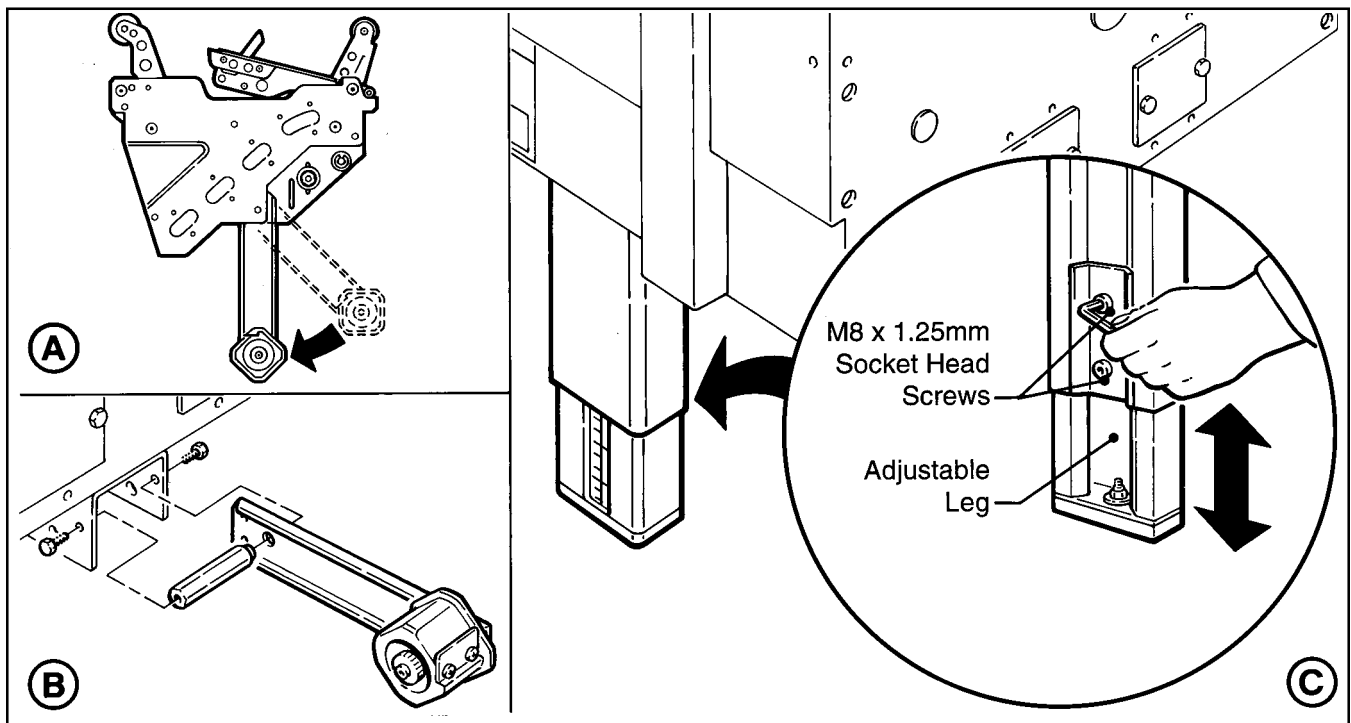

Figure 2-5 – Machine Bed Height Adjustment and Lower Tape Drum Bracket Position

Installation and Set-Up (Continued)

BUMPER SUPPORTS (Upper Drive Assembly)

WARNING

- **To reduce the risk associated with impact hazards:**
 - Always use appropriate supporting means when working under the upper drive assembly

Raise and lock the upper drive assembly into its raised position. See "Operation – Mechanical Latch."

Install the two bumper supports, one on each side column using lower holes in bracket as shown in Figure 2-6. (The upper set of holes allows the upper drive assembly to return to a lower position. However, this minimum position can only be used if the taping heads are adjusted to apply 50 mm [2 inch] long tape legs.)

***Note** – Interference and damage to the taping heads may occur if the upper mounting bracket holes are used with the taping heads at the standard setting (70 mm [2.75 inch] tape legs).*

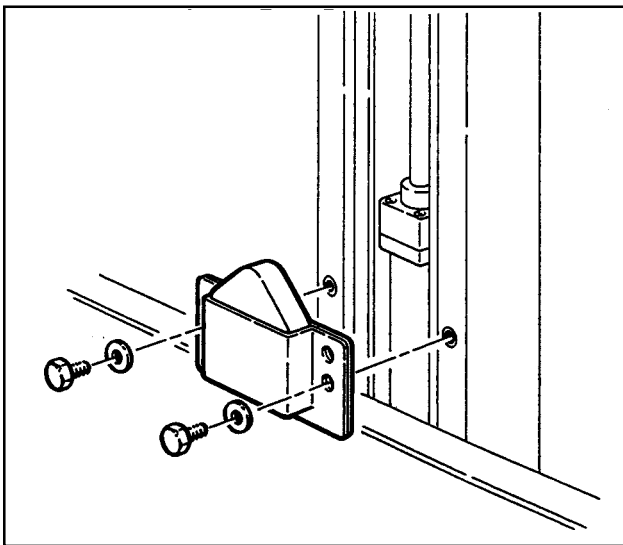

Figure 2-6 – Bumper Supports

BOX SIZE CAPACITY OF CASE SEALER

At its factory setting, the case sealer handles box sizes up to 620 mm [24.5 inch] maximum height. If larger capacity is needed, the machine can be adjusted to accommodate boxes up to 725 mm [28.5 inch] high. Refer to "Special Set-Up Procedure – Box and Machine Bed Height Range." **Note** – **Adjusting machine to accommodate 725 mm [28.5 inch] high boxes also increases minimum box size to 170 mm [6.8 inch].**

ELECTRICAL CONNECTION AND CONTROLS

The electrical control box and "On/Off" switch are located on the lower left side of the machine frame. See Figure 3-1. If desired, for operator convenience, the "On/Off" switch can be relocated to the right side of the machine frame. A standard three conductor power cord with plug is provided at the back of the electrical control box for 115 Volt, 60 Hz., 3.8 Amp electrical service. The receptacle providing this service shall be properly grounded. Before the power cord is plugged into 115 Volt, 60 Hz outlet make sure that all packaging materials and tools are removed from the machine. **Do not plug electrical cord into outlet until ready to run machine.**

Use of an extension cord is not recommended. However, if one is needed for temporary use, it must have a wire size of 1.5 mm diameter [AWG 16], have a maximum length of 30.5 m [100 ft], and must be properly grounded.

WARNING

- **To reduce the risk associated with hazardous voltage:**
 - Position electrical cord away from foot and/or vehicle traffic

***Note** - Machines outside the U.S. may be equipped with 220/240 Volt, 50 Hz systems, or other electrical requirements compatible with local practice.*

INITIAL START-UP OF CASE SEALER

After completing the "Installation and Set-Up" procedure, continue through "Operation" for tape loading and start-up to be sure case sealer is properly adjusted to run boxes

Operation

WARNING

- To reduce the risk associated with mechanical and electrical hazards:
 - Read, understand and follow all safety and operating instructions before operating or servicing the case sealer

Refer to Figure 3-1 and 3-2 below to acquaint yourself with the various components and controls of the case sealer. Also see Figures 3-1 and 3-2 in Section II for taping head components.

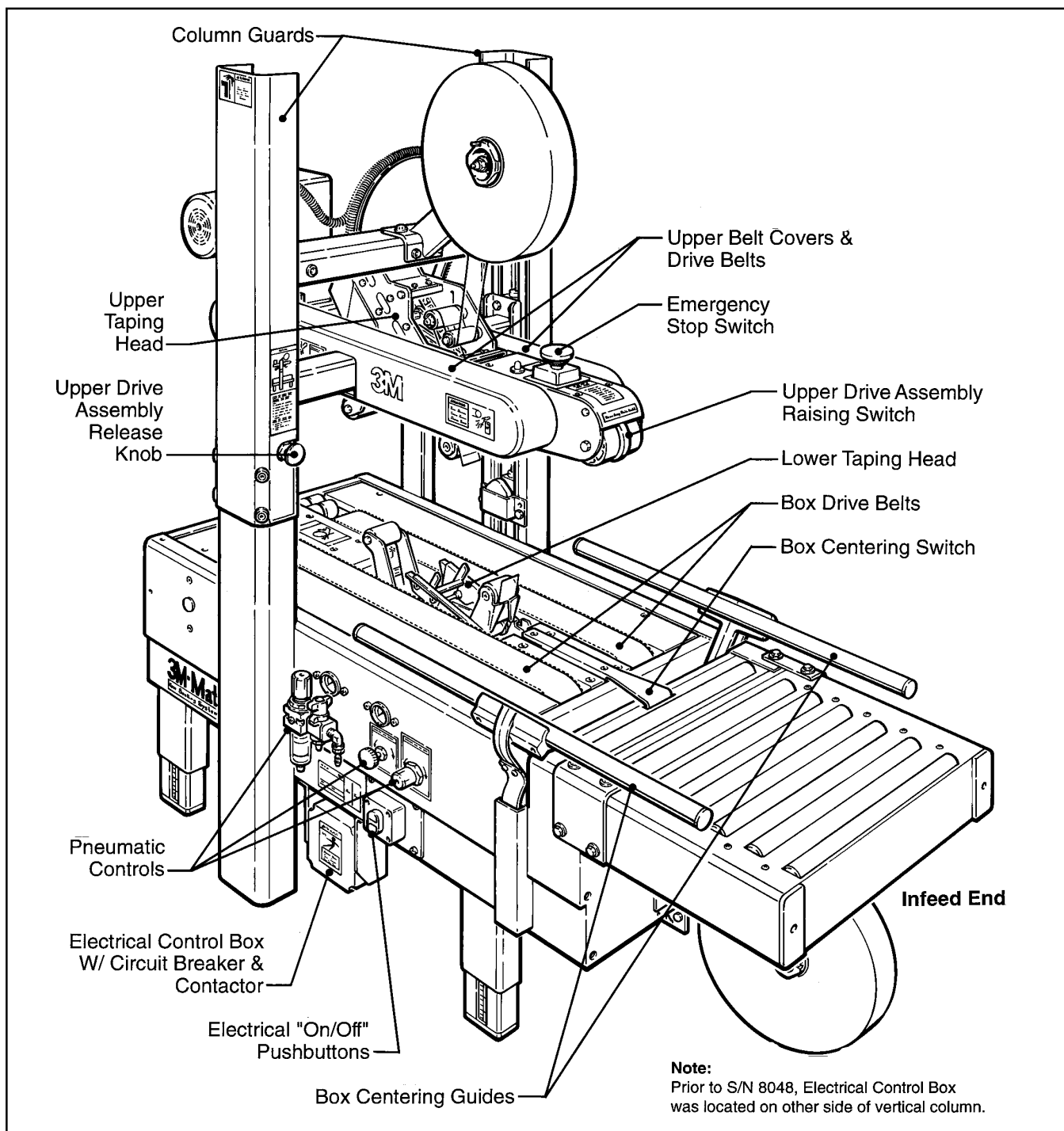

Figure 3-1 – 700r3 Case Sealer Components (Left Front View)

Operation (Continued)

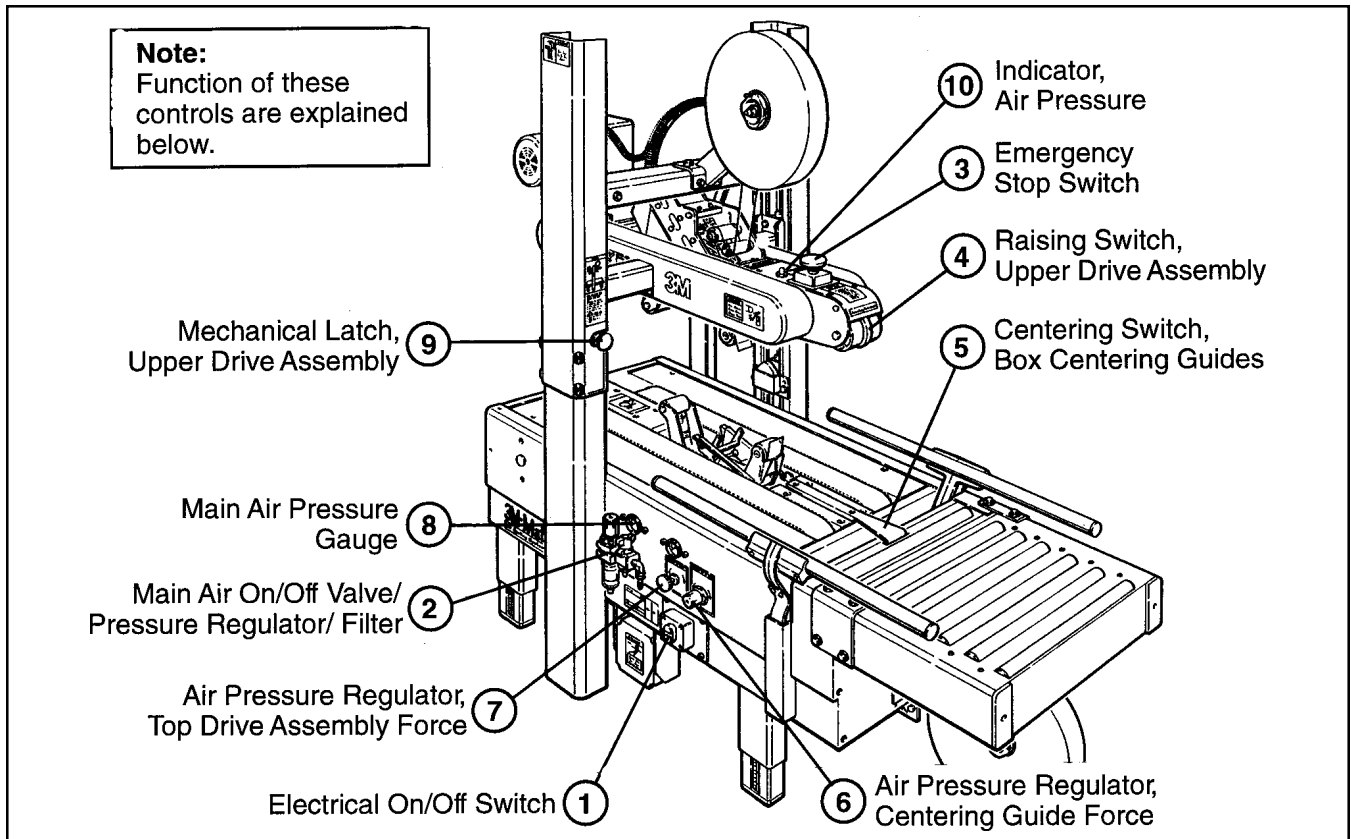

Figure 3-2 – Controls, Valves and Switches

- 1 Electrical "On/Off" Switch**
The box drive belts are turned on and off ("Off" button is red) with the electrical switch on the side of the machine frame.

Always turn the air "Off" when machine is not in use, when servicing the machine, or when connecting or disconnecting air supply line.

Note – The case sealer has a circuit breaker located in the electrical enclosure on the lower left side of the machine frame. If circuit becomes overloaded and circuit breaker trips, **unplug the machine electrical cord** and determine cause of overload. After two minutes, remove the electrical control box cover and reset the circuit breaker by pressing the "Reset" button and then the "Start" button on the circuit breaker. Replace the control box cover, plug machine electrical cord into outlet and restart machine by pressing green "On" button.

Note – The air valve has provisions for lockout/tagout according to plant regulations.

- 2 Main Air "On/Off" Valve/Pressure Regulator/Filter** – Figure 3-3
This set of pneumatic components controls, regulates and filters plant air supply to the two separate control circuits of the case sealer.

"On/Off" Valve – "On" turn to "SUP" – "Off" turn to "EXH". **Note** – Turning air supply "Off" automatically bleeds air pressure from the case sealer air circuits.

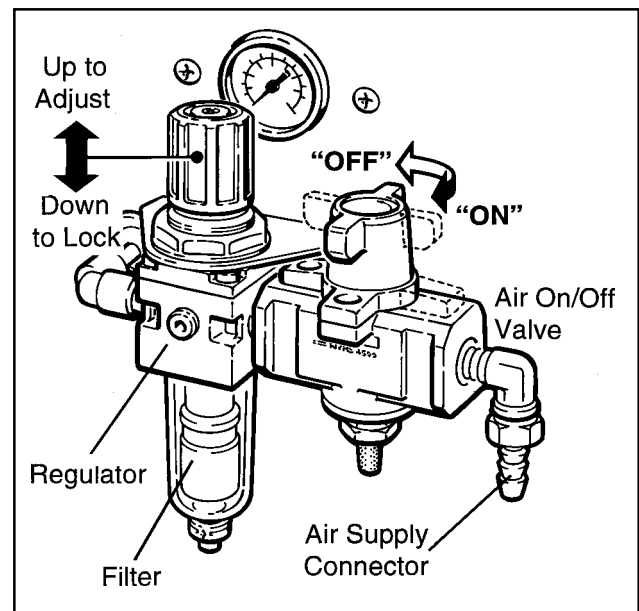

Figure 3-3 – "On/Off" Valve/Regulator/Filter

Operation (Continued)

Pressure Regulator regulates main air pressure to the machine to adjust pressure, pull knob up and turn – push down to lock setting.

Filter removes dirt and moisture from plant air before it enters the case sealer pneumatic circuits. If water collects in bottom of bowl, lift up on the valve on the bottom of bowl to drain.

- ③ **Emergency Stop Switch**
The machine electrical supply can be turned off by pressing the latching emergency stop switch. To restart machine, rotate emergency stop switch (releases switch latch) and then restart machine by pressing green (On) button on side of machine frame.

- ④ **Raising Switch, Upper Drive Assembly**
This switch, when touched by the leading edge of a box, pneumatically raises the upper frame to allow insertion of the box under the drive belts. As the box moves under the switch, releasing it, the upper drive assembly descends on the box and the drive belts convey the box through the machine. When switch is actuated by hand, the upper drive assembly rises to its maximum height. Released, the upper drive assembly descends to its rest position.

- ⑤ **Centering Switch, Box Centering Guide**
This pneumatic switch controls the box centering guides. When switch is activated by a box entering the case sealer, the centering guides close (centering the box), and released (after box passes over switch), the guides open.

- ⑥ **Air Pressure Regulator, Centering Guide Force Adjustment** – Figure 3-4
This regulator is used to adjust centering guides according to weight of boxes. Pressure should be adequate to center boxes, but low enough to allow easy pushing of boxes under taping head. The regulator setting can be locked by tightening the phillips screw as shown.

- ⑦ **Air Pressure Regulator/Gauge, Top Drive Assembly Force Adjustment** – Figure 3-5
Set nominally to control "down" movement of top drive assembly and the pressure exerted against the box. The regulator setting is changed as necessary for the boxes being sealed to provide adequate drive belt pressure

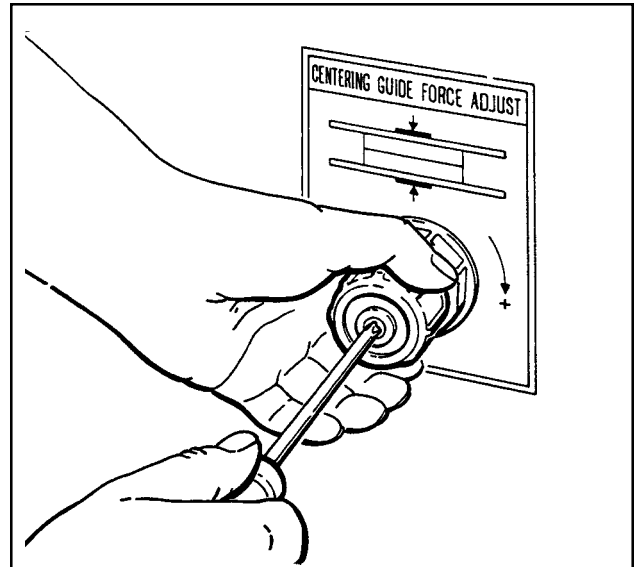

Figure 3-4– Air Regulator, Centering Guides

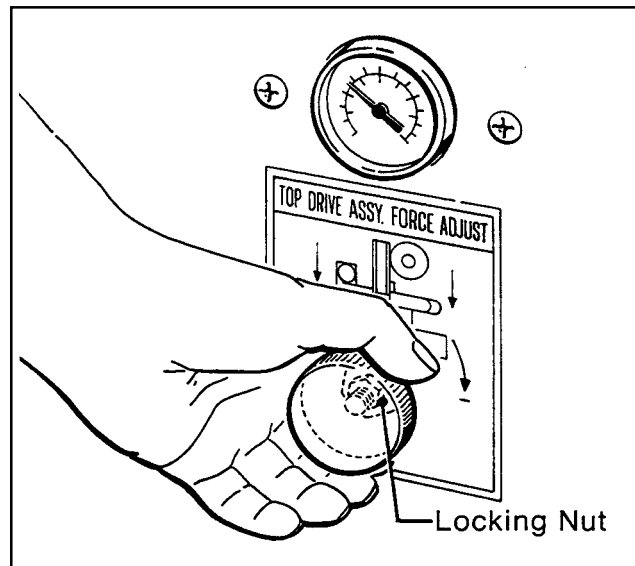

Figure 3-5 – Air Regulator/Gauge, Top Drive Assembly

against the box to positively convey the boxes through the machine. If the boxes stop or hesitate while being conveyed, decrease the regulator pressure which will increase the drive belt force on the box for more friction between the box and drive belts. Adjust setting as necessary to get continuous movement of boxes through machine.

Operation (Continued)

For boxes which are fully packed with products that support the top flaps, the adjustment of this regulator is not critical since the boxes can support the pressure of the upper frame (drive belts) at a wide range of regulator settings. However, if under-filled or fragile boxes are sealed, this regulator can be used to set the upper frame pressure to a minimum that is still adequate to positively convey the box and to prevent damage of boxes. The regulator setting can be locked by securing the lock nut on the regulator shaft as shown in Figure 3-5.

Note – A precision regulator is used to balance the top drive assembly. Due to the self relieving feature of this regulator a small amount of air will continually vent to the atmosphere. This is normal and amounts to approximately 3 liter/min [0.1 SCFM].

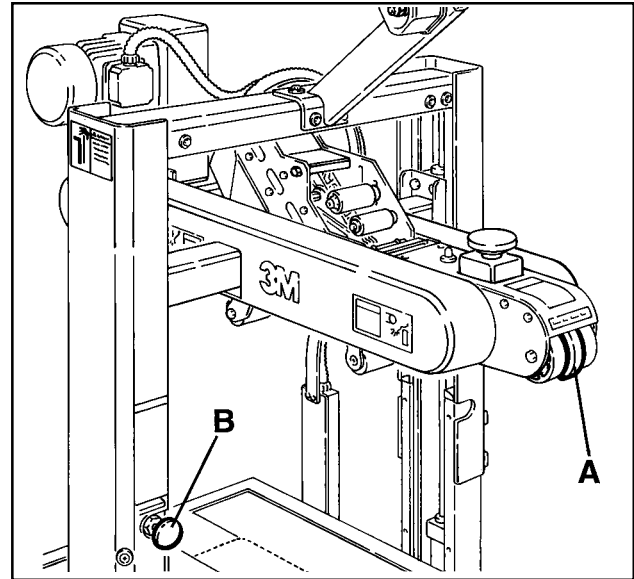

Figure 3-6 – Mechanical Latch, Upper Drive Assembly

- ⑧ **Main Air Pressure Gauge**
Indicates main air regulator pressure setting. Air regulator should be adjusted so gauge reads 5 bar gauge pressure [70 PSIG].
- ⑨ **Mechanical Latch, Upper Drive Assembly – Figure 3-6**
The mechanical latch is provided to hold the upper drive assembly at the fully raised position for tape threading and maintenance.

To raise and latch the upper drive assembly:

1. Push and hold the upper frame raising switch "A".
2. Push and hold latching knob "B".
3. Release switch "A".
4. Release knob "B".
5. Shut off air supply.

To release and lower the upper drive assembly:

1. Turn on air supply.
2. Push and release switch "A".

- ⑩ **Indicator, Air Pressure**
An "Optical Warning Indicator" for the compressed air circuit of the machine is located on the upper drive assembly just behind the red "Stop" button. When indicator is "Red", air circuit is on.

Operation (Continued)

Important – Before turning drive belts on, be sure no tools or other objects are on the conveyor bed.

Tape Loading/Threading

See Section II.

Note – If lower tape drum is mounted in alternate lower outboard position, remove taping head from machine bed by pulling taping head straight up, insert threading needle in taping head and replace taping head. Install tape roll on drum (adhesive on tape leg up), thread tape under knurled roller on outboard mount, then attach tape to threading needle and pull tape through taping head with threading needle.

WARNING

- **To reduce the risk associated with muscle strain:**
 - Use proper body mechanics when removing or installing taping heads that are moderately heavy or may be considered awkward to lift

Theory of Operation

CAUTION

- **To reduce the risk associated with pinch and entanglement hazards:**
 - Always feed boxes into the machine by pushing only from the end of the box
 - Keep hands clear of the upper head support assembly as boxes are transported through the machine
- **To reduce the risk associated with pinch and impact hazards:**
 - Keep away from the pneumatically controlled upper drive assembly and box centering guides when air and electric supplies are on

The air supply powers movement of the centering guides and upper drive assembly to automatically adjust the case sealer to the box size being sealed as follows:

1. A box centering switch in the center of the infeed roller conveyor actuates movement of the centering guides. When the operator pushes a box onto the infeed conveyor, as shown in Figure 3-7, the lever is depressed causing the air cylinder powered centering guides to move inward, thereby centering the box.

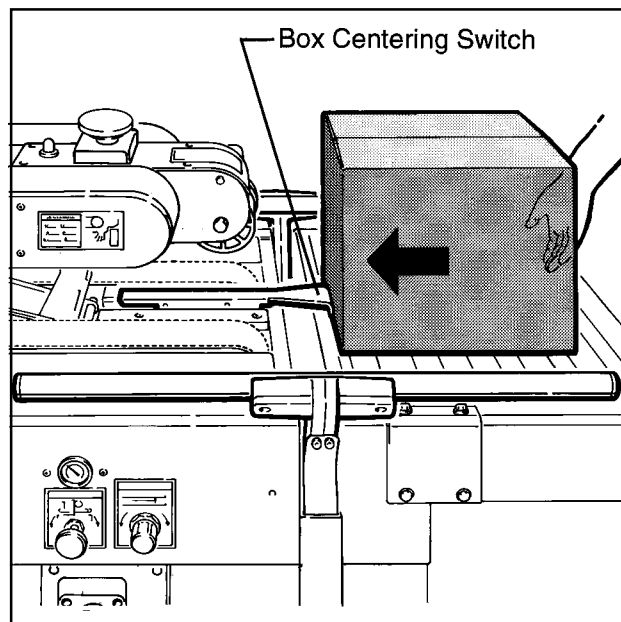

Figure 3-7 – Box Centering Switch

2. Once the box is centered by the guides, the operator pushes the box against the raising switch on the upper drive assembly, as shown in Figure 3-8, causing the upper taping head to be raised by two air cylinders. The upper taping head will continue to rise above the box height so the operator can insert the box underneath the upper drive belts.

CAUTION

- **To reduce the risk associated with pinch and entanglement hazards:**
 - Keep hands clear of the upper head support assembly as boxes are transported through the machine

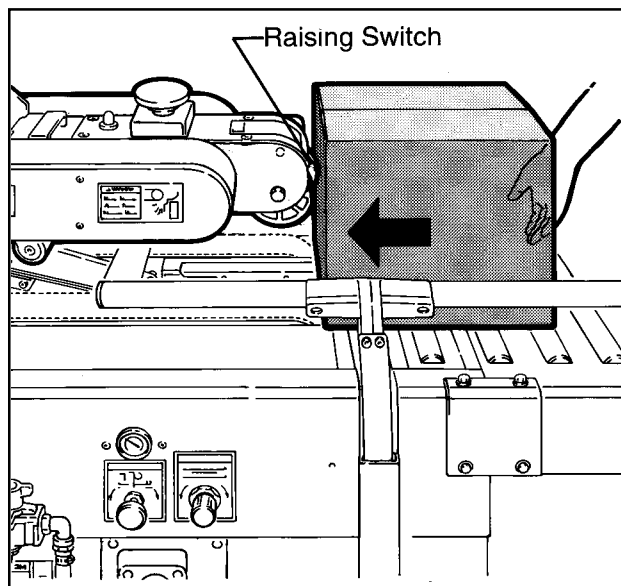

Figure 3-8 – Drive Assembly Raising Switch

Operation (Continued)



CAUTION

- **To reduce the risk associated with pinch and entanglement hazards:**
 - Keep hands, hair, loose clothing, and jewelry away from moving belts and taping heads

3. Once the box is pushed under the upper taping head, the upper drive assembly raising switch is released causing the upper drive assembly to descend onto the box top, as shown in Figure 3-9, allowing the drive belts to convey the box through the upper and lower taping heads for application of the tape seals.
4. As the box is conveyed through the machine, the box centering switch is released causing the centering guides to return to their full open position, ready for insertion of the next box.
5. Once the box is conveyed from under the upper taping head, the upper drive assembly descends to its rest position, ready for insertion of the next box.

At this point it is recommended that the centering guides and upper drive assembly switches be manually actuated to understand the functions described above. Depressing the box centering switch causes the guides to close, releasing the switch causes the guides to open. Depressing the upper drive assembly raising switch causes the upper drive assembly to rise, releasing the switch causes the drive assembly to descend.

Box Sealing

1. Turn main air valve to "SUP" (On).
2. Press green electrical pushbutton on side of machine frame to start drive belts.
3. Feed boxes to machine allowing previous box to exit machine BEFORE feeding next box.
4. Turn air and electrical supplies "Off" when machine is not in use.
5. Reload and thread tape as necessary.
6. Be sure machine is cleaned and lubricated according to recommendations in "Maintenance" section of this manual.

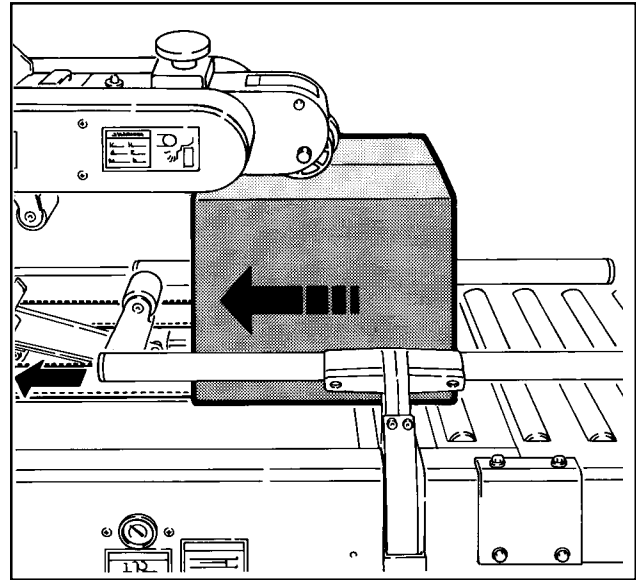

Figure 3-9 – Drive Belts

Notes –

1. *Machine or taping head adjustments are described in "Adjustments" Section I for machine or Section II for taping heads.*
2. *Box drive motors are designed to run at a moderate temperature of 40°C [104°F]. In some cases, they may feel hot to the touch.*

Maintenance

The case sealer has been designed for long, trouble free service. The machine will perform best when it receives routine maintenance and cleaning. Machine components that fail or wear excessively should be promptly repaired or replaced to prevent damage to other portions of the machine or to the product.



WARNING

- **To reduce the risk associated with mechanical and electrical hazards:**
 - Turn electrical and air supply off and disconnect before performing any adjustments, maintenance, or servicing the machine or taping heads
- **To reduce the risk associated with impact hazards:**
 - Always use appropriate supporting means when working under the upper drive assembly

Cleaning

Note – Never attempt to remove dirt from the machine by blowing it out with compressed air. This can cause the dirt to be blown inside the motor and onto sliding surfaces which may cause premature equipment wear. Never wash down or subject equipment to conditions causing moisture condensation on components. Serious equipment damage could result.

Regular slotted containers produce a great deal of dust and paper chips when processed or handled in equipment. If this dust is allowed to build-up on machine components, it can cause component wear and overheating of drive motor. The dust build-up can best be removed from the machine by a shop vacuum. Depending on the number and type of boxes sealed in the case sealer, this cleaning should be done approximately once per month. If the boxes sealed are dirty, or if the environment in which the machine operates is dusty, cleaning on a more frequent basis may be necessary. Excessive dirt build-up that cannot be removed by vacuuming should be wiped off with a damp cloth.

Lubrication

Most of the machine bearings, including the drive motor, are permanently lubricated and sealed and do not require additional lubricant.

Figure 4-1 illustrates the machine points that do require lubrication every 250 hours of operation. Lubricate the points indicated by arrows (⇒) with a small amount of multi-purpose grease.

Note – Wipe off excess oil and grease. It will attract dust which can cause premature equipment wear and jamming. Take care that oil and grease are not left on the surface of rollers around which tape is threaded, as it can contaminate the tape's adhesive.

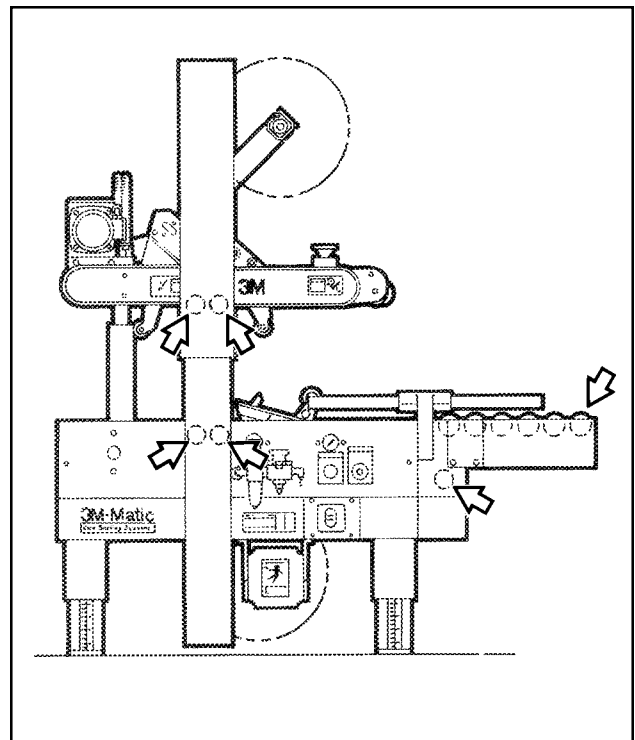

Figure 4-1 – Lubrication Points – Frame

Maintenance (Continued)

WARNING

- **To reduce the risk associated with mechanical and electrical hazards:**
 - Turn electrical and air supply off and disconnect before performing any adjustments, maintenance or servicing the machine or taping heads
- **To reduce the risk associated with impact hazards:**
 - Always use appropriate supporting means when working under the upper drive assembly

Box Drive Belt Replacement

Note – 3M recommends the replacement of drive belts in pairs, especially if belts are unevenly worn.

LOWER DRIVE BELTS

Figure 4-2

1. Remove and retain center plates **(A)** and four screws.
2. Remove and retain side cover **(B)** and fasteners.
3. Loosen, but do not remove lock nut **(C)**.
4. Loosen tension screw **(D)** until all belt tension is removed.
5. Pull belt splicing pin **(E)** out and remove belt.
6. Place new belt over pulleys with laced splice at top. **Note** – Pin must not extend beyond edge of belt.
7. Adjust belt tension as explained in "Adjustments – Box Drive Belt Tension".
8. Replace side cover and center plates and secure with original fasteners.

UPPER DRIVE BELTS

Figure 4-3

1. Remove and retain center plate **(A)** and four screws and plain washers.
2. Loosen, but do not remove lock nut **(B)**.
3. Loosen tension screw **(C)** until all tension is removed from belt.
4. Remove 4 screws on side of belt guard **(D)** and slide belt guard out to expose belt.
5. Pull belt splicing pin **(E)** out and remove belt.
6. Place new belt over pulleys with laced splice at top. **Note** – Pin must not extend beyond edge of belt.
7. Adjust belt tension as explained in "Adjustments – Box Drive Belt Tension".
8. Replace front cover and belt guard(s) and secure with original fasteners.

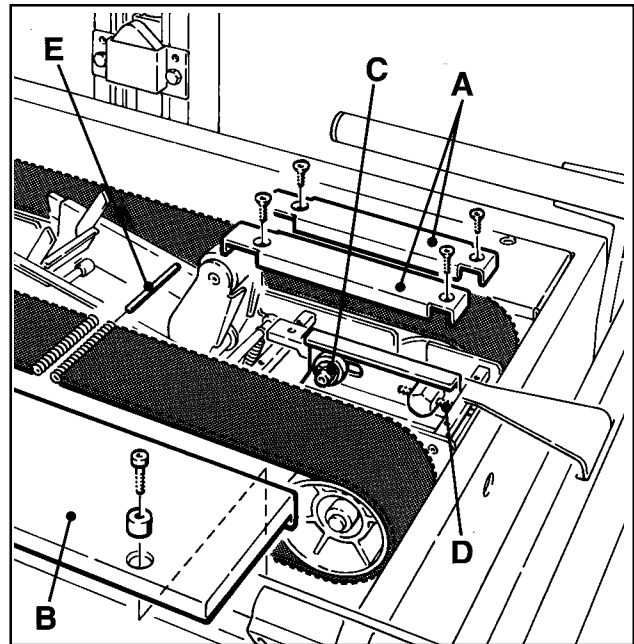
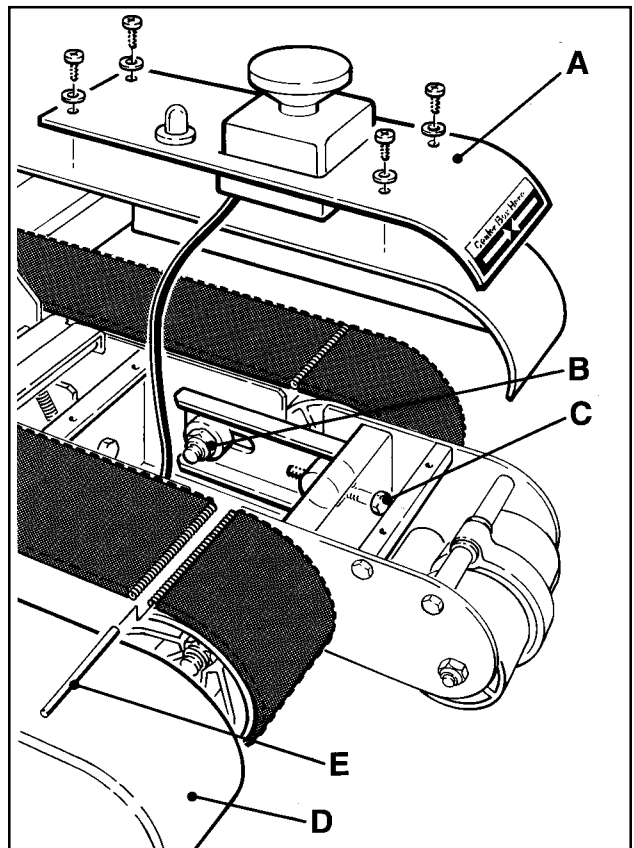

Figure 4-2 – Lower Drive Belt Replacement



23 Figure 4-3 – Upper Drive Belt Replacement

Maintenance (Continued)



WARNING

- **To reduce the risk associated with mechanical and electrical hazards:**

- Turn electrical and air supply off and disconnect before performing any adjustments, maintenance or servicing the machine or taping heads

Circuit Breaker

The case sealer is equipped with a circuit breaker which trips if the motors are overloaded. Located inside the electrical enclosure on the side of the machine frame just below the machine bed, the circuit breaker has been pre-set at 2.2 amps and requires no further maintenance.

If circuit is overloaded and circuit breaker trips, unplug machine from electrical power:

1. Determine cause of overload and correct.
2. Remove electrical enclosure cover.
3. Press "Reset" and then "Start" buttons on circuit breaker. If circuit breaker will not reset, wait 2 minutes and retry.
4. Replace cover.
5. Plug in machine.
6. Press machine "On" button to resume case sealing.

Knife Replacement, Taping Head

See Section II, "Maintenance – Blade (Knife) Replacement."

Adjustments

WARNING

- **To reduce the risk associated with mechanical and electrical hazards:**
 - Turn electrical and air supply off and disconnect before performing any adjustments, maintenance or servicing the machine or taping heads

Box Drive Belt Tension

The four continuously moving drive belts convey boxes through the tape applying mechanism. The box drive belts are powered by electric gear motors.

Tension adjustment of these belts may be required during normal operation. Belt tension must be adequate to positively move the box through the machine and the belts should run fully on the surface of the pulleys at each end of the frame. The idler pulleys on the infeed end are adjusted in or out to provide proper belt tension. Each belt is adjusted separately.

Belt tension is obtained by tightening the adjustment screw so that a moderate pulling force of 3.5 kg [7 lbs.] applied at the midspan, as shown in Figure 5-1, will deflect the belt 25 mm [1 inch]. This will assure positive contact between the belt and the drive pulley on the discharge end of the drive assembly. **Note – Figure 5-1 illustrates the lower drive belts, however, upper belts are adjusted in the same manner.**

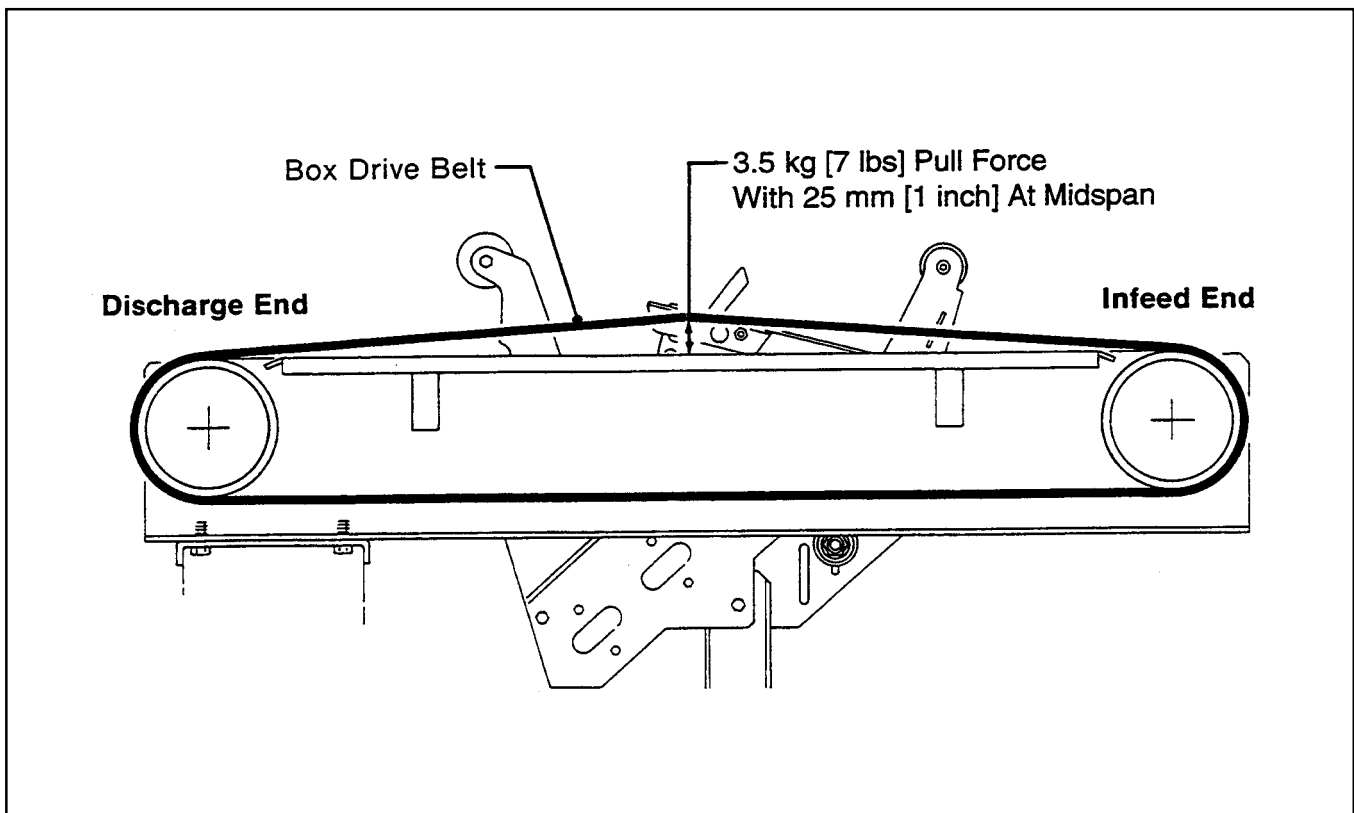

Figure 5-1 – Box Drive Belt Tension Adjustment

Adjustments (Continued)

WARNING

- To reduce the risk associated with mechanical and electrical hazards:
 - Turn electrical and air supply off and disconnect before performing any adjustments, maintenance or servicing the machine or taping heads

Refer to Figure 5-2 and 5-3 and adjust belt tension as follows:

1. Remove and retain center plates/front cover and four screws.
2. Loosen, but do not remove, M10 lock nut with a 17 mm open end wrench.
3. Reset the tension on the drive belts as needed. Adjust the M8 tension screws in (clockwise) to **increase** tension or out (counterclockwise) to **decrease** tension. Tighten lock nut to secure tension setting.
4. Replace center plates/front cover and secure with original screws.

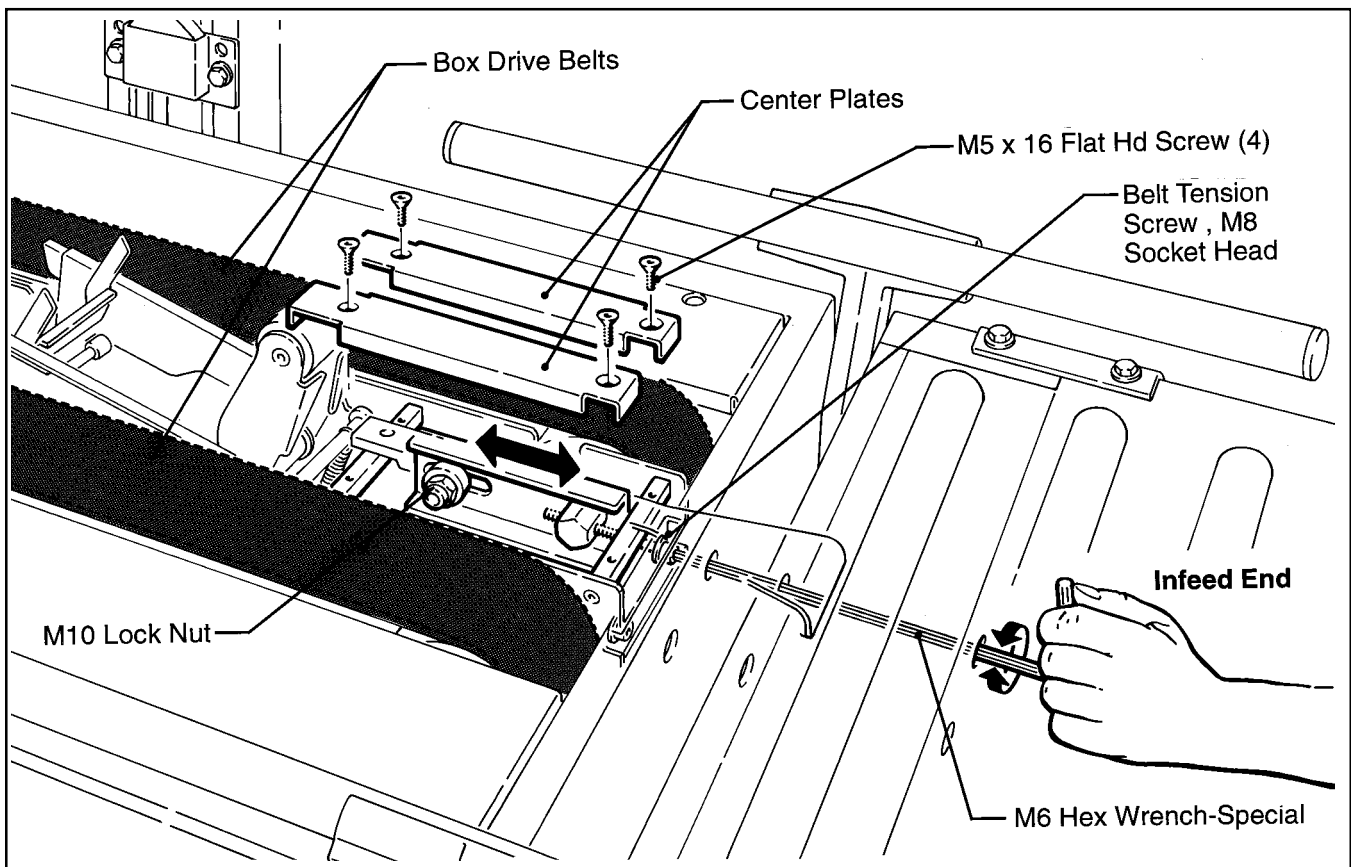

Figure 5-2 – Box Drive Belt Tension Adjustment, Lower Belts (Infeed End)

Adjustments (Continued)

WARNING

- **To reduce the risk associated with mechanical and electrical hazards:**

- Turn electrical and air supply off and disconnect before performing any adjustments, maintenance or servicing the machine or taping heads

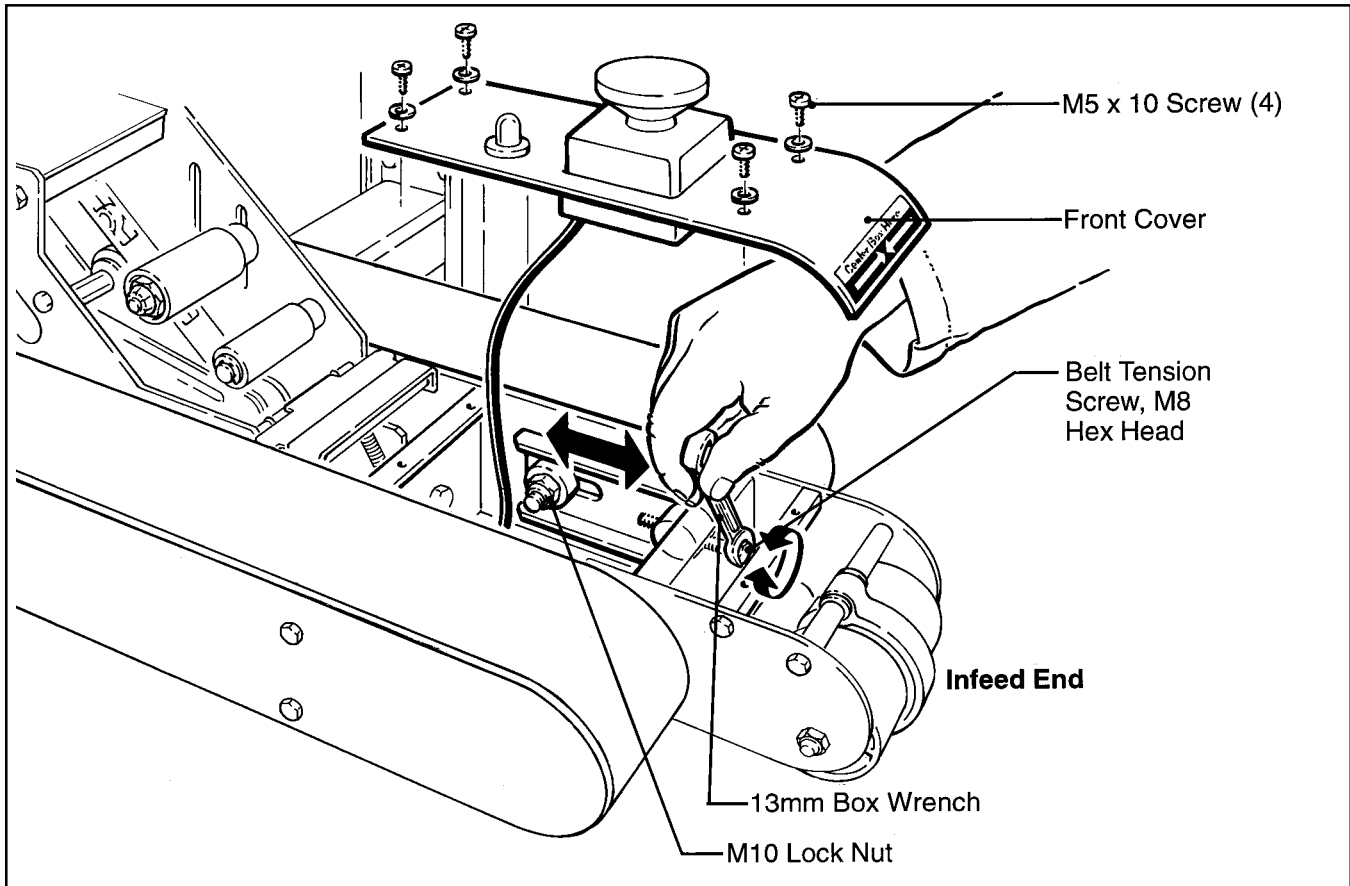

Figure 5-3 – Box Drive Belt Tension Adjustment, Upper Belts (Infeed End)

Taping Head Adjustments – Refer to Section II

WARNING

- **To reduce the risk associated with sharp blade hazards:**

- Keep hands and fingers away from tape cutoff blades under orange blade guards. The blades are extremely sharp

TAPE WEB ALIGNMENT – Section II

TAPE DRUM FRICTION BRAKE – Section II

APPLYING MECHANISM SPRING – Section II

ONE-WAY TENSION ROLLER – Section II

TAPE LEG LENGTH ADJUSTMENT – Section II

Special Set-Up Procedure

WARNING

- To reduce the risk associated with mechanical and electrical hazards:

- Turn electrical and air supply off and disconnect before performing any adjustments, maintenance or servicing the machine or taping heads

Changing the Tape Leg Length

(From 70 to 50 mm [2-3/4 to 2 inch])

The following changes to the case sealer frame and upper/lower taping heads reduces the tape leg length to 50 mm [2 inch] and also allows the taping of boxes 95 mm [3.75 inch] minimum height.

CASE SEALER FRAME

(Refer to Figure 6-1A)

1. Raise and latch upper drive assembly in upper position. Turn off air supply and electric power.
2. Remove and retain the screws, washers and bumper support assembly on both side columns. Remount and secure the bumper support assemblies using the top holes and original fasteners.
3. Be sure adjustable split collars on column cylinder rods are loose or clamped at the top of the cylinder rod to allow the upper drive assembly to descend fully.

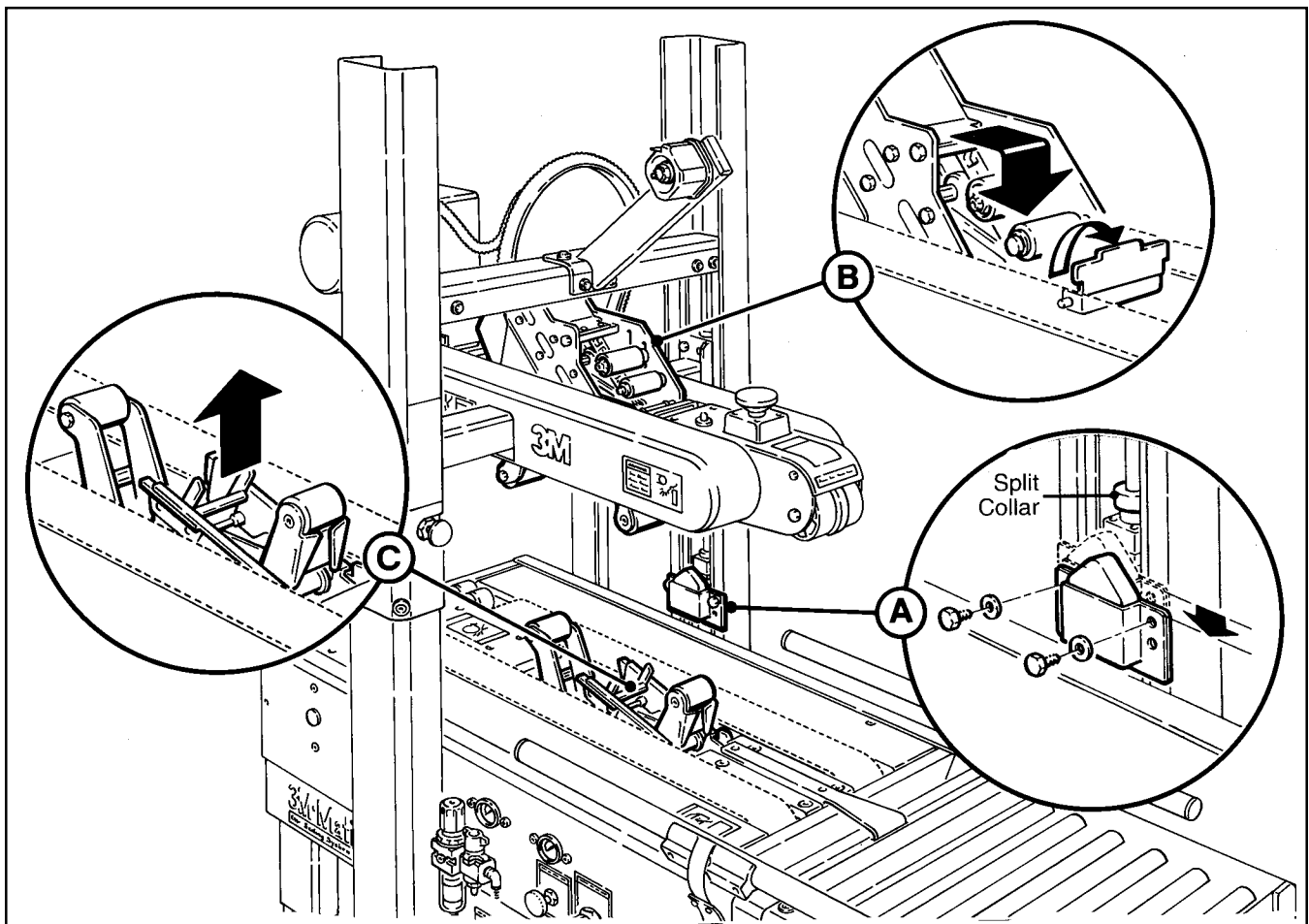

Figure 6-1 – Case Sealer Frame Changes

Special Set-Up Procedure (Continued)

WARNING

- **To reduce the risk associated with mechanical and electrical hazards:**
 - Turn electrical and air supply off and disconnect before performing any adjustments, maintenance or servicing the machine or taping heads

TAPING HEADS

WARNING

- **To reduce the risk associated with sharp blade hazards:**
 - Keep hands and fingers away from tape cutoff blades under orange blade guards. The blades are extremely sharp

With upper drive assembly in raised position:

1. Remove tape from upper taping head.
2. Pivot up the clamp that secures the upper taping head as shown in Figure 6-1B.
3. Hold upper taping head applying and buffing arms from under upper assembly, slide head forward and down to remove. See Figure 6-2.

WARNING

- **To reduce the risk associated with muscle strain:**
 - Use proper body mechanics when removing or installing taping heads that are moderately heavy or may be considered awkward to lift

4. Lift the lower taping head, shown in Figure 6-3 and 6-1C, straight up to remove it from the case sealer bed.
5. Refer to Section II, "Adjustments – Changing Tape Leg Length," for taping head set-up.
6. Replace taping heads reverse of disassembly. Turn on air supply and electric power, unlatch upper drive assembly and allow it to return to its rest position.

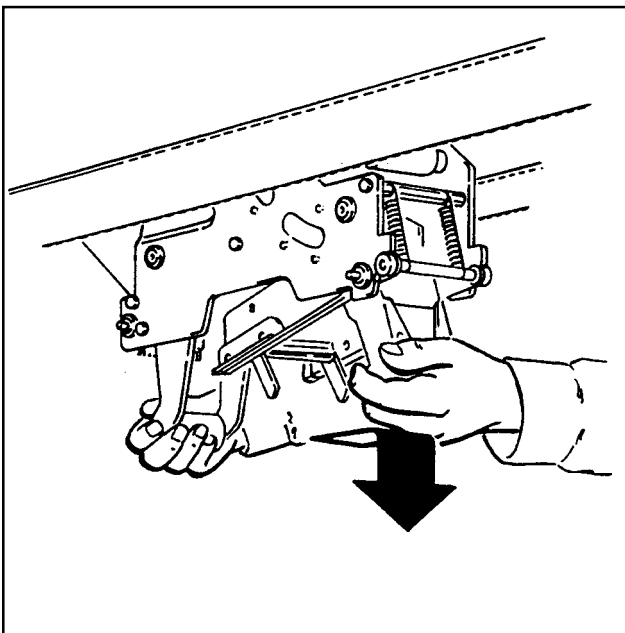

Figure 6-2 – Remove Upper Taping Head

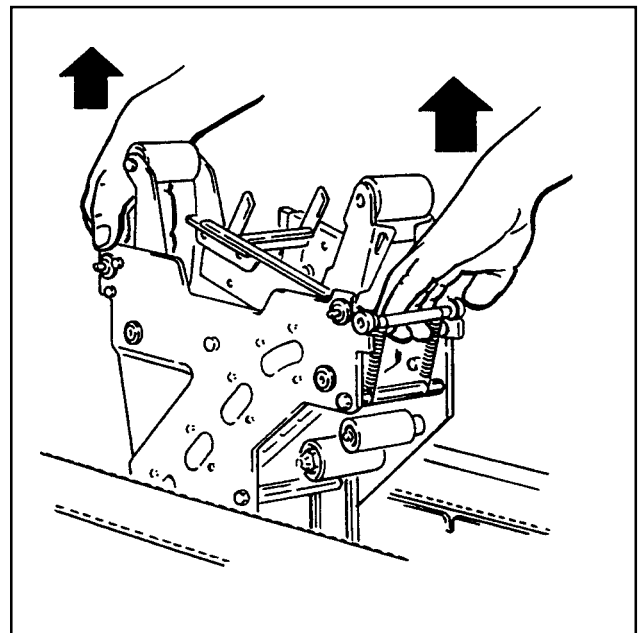

Figure 6-3 – Remove Lower Taping Head

Special Set-Up Procedure (Continued)

WARNING

- To reduce the risk associated with mechanical and electrical hazards:

- Turn electrical and air supply off and disconnect before performing any adjustments, maintenance or servicing the machine or taping heads

Box and Machine Bed Height Range – Refer to Figure 6-4

Moving the outer columns up one set of mounting holes increases the maximum box size handled by the 700r3 case sealer and decreases the minimum machine bed height. **Note – This also increases the minimum box height from 120 mm [4.8 inch] to 170 mm [6.8 inch].**

To move the outer columns up one set of mounting holes:

1. Lift the upper taping head/drive assembly up and place a 200 - 250 mm [8 - 10 inch] block at the front and rear of the upper drive assembly. **Important – Blocks (front and rear) must be same height in order to keep upper drive assembly parallel with machine bed.** Also, block both columns up with solid spacers between outer columns and floor. See Figure 6-4A.
2. Remove and retain the six screws and plain washers that fasten each column to the frame. Figure 6-4B.
3. Lift the outer columns up one set of mounting holes, (100 mm [4 inch]) and place 100 mm [4 inch] spacers between the blocks on the floor and each column. See Figure 6-4C.

WARNING

- To reduce the risk associated with muscle strain:

- Use the appropriate rigging and material handling equipment when lifting or repositioning this equipment

- To reduce the risk associated with impact hazards:

- Always use appropriate supporting means when working under the upper drive assembly

4. Install and tighten the six screws and plain washers in each column that were removed in Step 2. Turn on air supply, raise and lock upper drive assembly in fully raised position and remove all blocks and spacers.

If desired, the bed height can now be decreased to 570 mm [22.5 inch] by adjusting legs upward. (See "Installation and Set-Up – Machine Bed Height.")

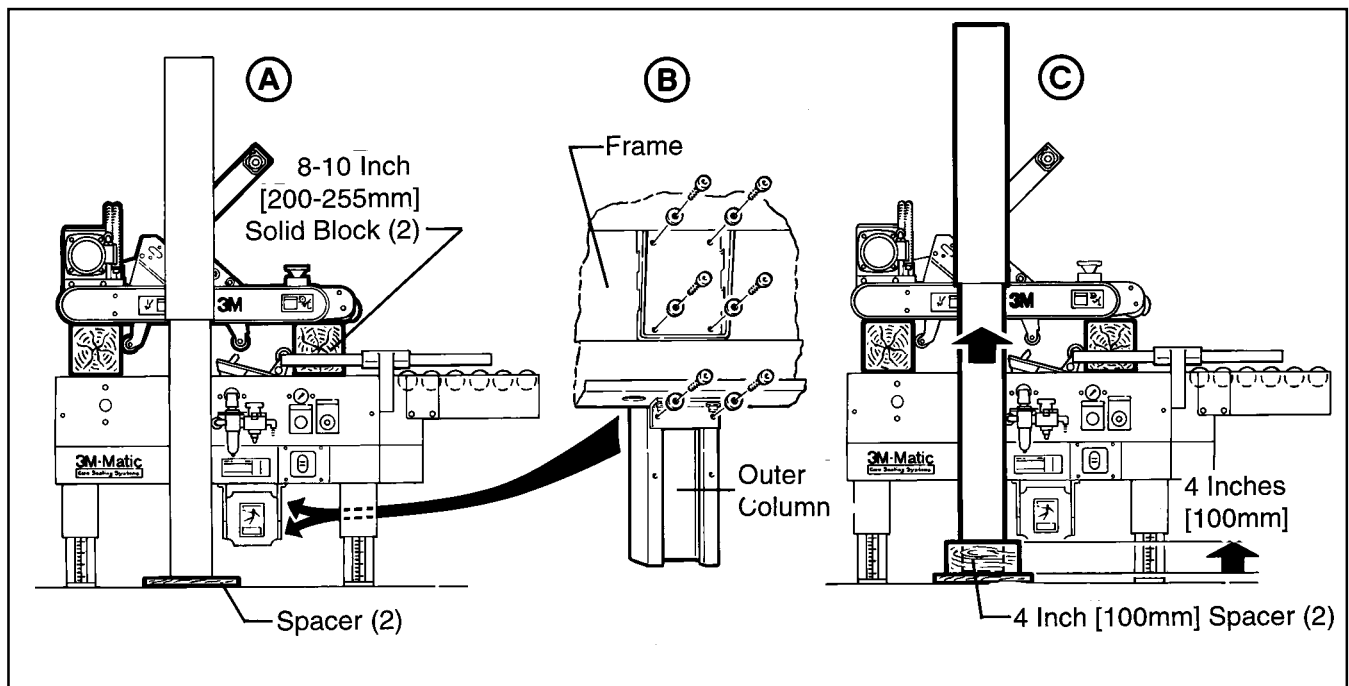

Figure 6-4 – Box and Machine Bed Height Range 30

Special Set-Up Procedure (Continued)

WARNING

- **To reduce the risk associated with mechanical and electrical hazards:**

- Turn electrical and air supply off and disconnect before performing any adjustments, maintenance or servicing the machine or taping heads

Box Height Range – (Refer to Figure 6-5)

The operating range of the upper drive assembly can be adjusted to minimize its movement to the range of box heights being sealed. Therefore, the operating speed can be increased. The range is established by limiting the lowest position of the drive assembly by positioning the stop bumpers at one of eight different levels on the side columns.

The illustration in Figure 6-5 shows minimum box height with stop bumpers fastened through lower holes (A) at different levels on the side columns. If bumpers are mounted with bolts through upper holes (B), the minimum height of box in each position **decreases** by 20 mm [3/4 inch].

WARNING

- **To reduce the risk associated with muscle strain:**

- Use proper body mechanics when removing or installing taping heads that are moderately heavy or may be considered awkward to lift

After establishing the minimum box height to be sealed, position the stop bumpers as follows:

1. Latch upper drive assembly in upper position, **turn off air and electric.**
2. Remove and relocate the stop bumper assembly to the desired position on both side columns. Be sure that the stop bumpers are reassembled as shown and secure.
3. Turn on the air and electrical power to the case sealer. The upper taping head will now descend only part way thus increasing operating speed.

In addition to the bumper supports, adjustable split collars are fitted onto the cylinder rods as shown in Figure 6-5. These can be used to stop the down position of the upper assembly at any position. To adjust these collars, position the smallest box to be sealed under the drive belts and stop the machine. Slide the collars on both cylinders down to the cylinder cap and tighten. Upper drive assembly will now stop at this position.

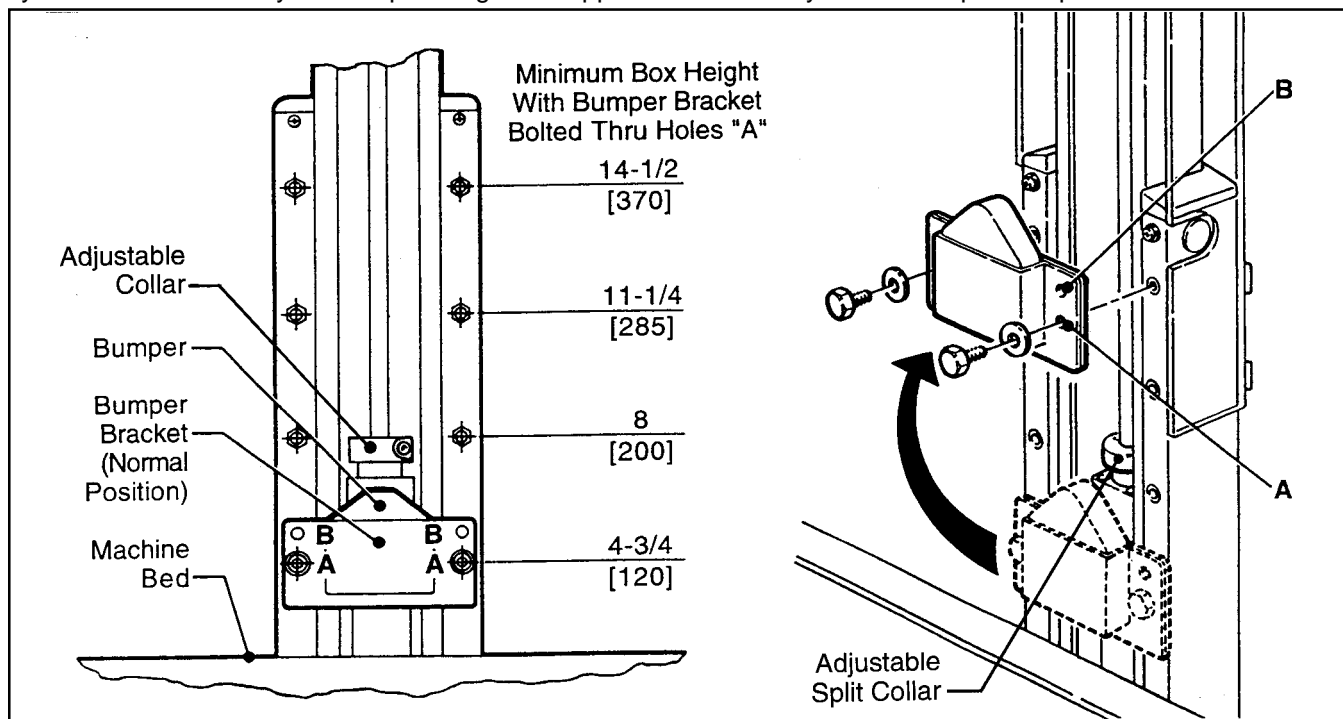

Figure 6-5 – Stop Bumpers

Troubleshooting

The Troubleshooting Guide lists some possible machine problems, causes and corrections. Also see Section II "Troubleshooting" for taping head problems.

Troubleshooting Guide

Problem	Cause	Correction
Drive belts do not convey boxes	Narrow boxes	Check machine specifications. Boxes are narrower than recommended, causing slippage and premature belt wear.
	Worn drive belts	Replace drive belts
	Top taping head does not apply enough pressure	Adjust the upper drive assembly force adjust regulator to increase the fore against the top of the box. Turn air regulator counterclockwise
	Taping head applying spring holder missing	Replace spring holder
Drive belts do not turn	Taping head applying spring set too high	Reduce spring pressure
	Worn or missing friction rings	Replace friction rings
	Drive belt tension too low	Adjust belt tension
	Electrical disconnect	Check power and electrical plug
Upper and lower applying mechanisms interfere with each other	Circuit breaker not at correct setting	Set to correct current value
	Motor not turning	Evaluate problem and correct
	Machine's minimum height stop does not match tape head leg length setting	Check manual to make sure taping heads match machine setting
	Drive belts break	Worn belt
Squeaking noise as boxes pass through machine	Dry compression rollers	Lubricate compression rollers
	Dry column bearings	Lubricate column bearings
	Defective column bearings	Replace column bearings
Tape not centered on box seam	Tape drum not centered	Reposition tape drum
	Centering guides not centered	Adjust centering guides
	Box flaps not of equal length	Check box specifications

(Continued)

Troubleshooting (Continued)

Troubleshooting Guide

Problem	Cause	Correction
Upper drive assembly does not move up or moves up slowly	Lower air pressure	Disconnect the air supply. Make sure main pressure regulator reads zero. Reconnect air supply and adjust regulator to read 70 PSIG [5 bar].
	Defective head raising valve	Clean or replace head raising valve
	Worn head raising valve actuator	Replace valve
	Clogged or damaged exhaust mufflers on the upper ends of the head raising cylinders	Clean or replace exhaust mufflers
	Defective head power valve	Clean or replace the head power valve
Upper taping head does not move down at the end of the taping cycle	Upper drive assembly force adjust regulator set too light	Adjust the upper drive assembly force adjust regulator to increase the force against the top of the box. Turn air regulator counterclockwise.
	Defective top drive assembly force adjust regulator	Replace regulator
	Defective one-way valve	Clean or replace valve
	Defective head power valve	Clean or replace valve
Upper drive assembly comes down too fast or too hard	Upper drive assembly force adjust regulator set too heavy	Adjust upper drive assembly force adjust regulator to decrease force against top of box. Turn regulator clockwise.
	Defective upper drive assembly force adjust regulator	Replace regulator
	Cushion screw misadjusted	Adjust cushion screw at base of cylinder
	Cushion screw missing	Replace screw
Centering guides move slower than normal	Centering guide force adjust regulator set too low	Adjust regulator
	Centering guide cylinder speed controls not in correct adjustment	Adjust speed controls mounted on centering guide cylinder
	Defective centering guide power valve	Clean or replace valve

Electrical Diagram



WARNING

• To reduce the risk associated with mechanical and electrical hazards:

- Turn electrical and air supply off and disconnect before performing any adjustments, maintenance or servicing the machine or taping heads

Rated Voltage - 600 Volts
 Rated Thermal Current - 25 Amps
 Set Point - 2.2 Amps

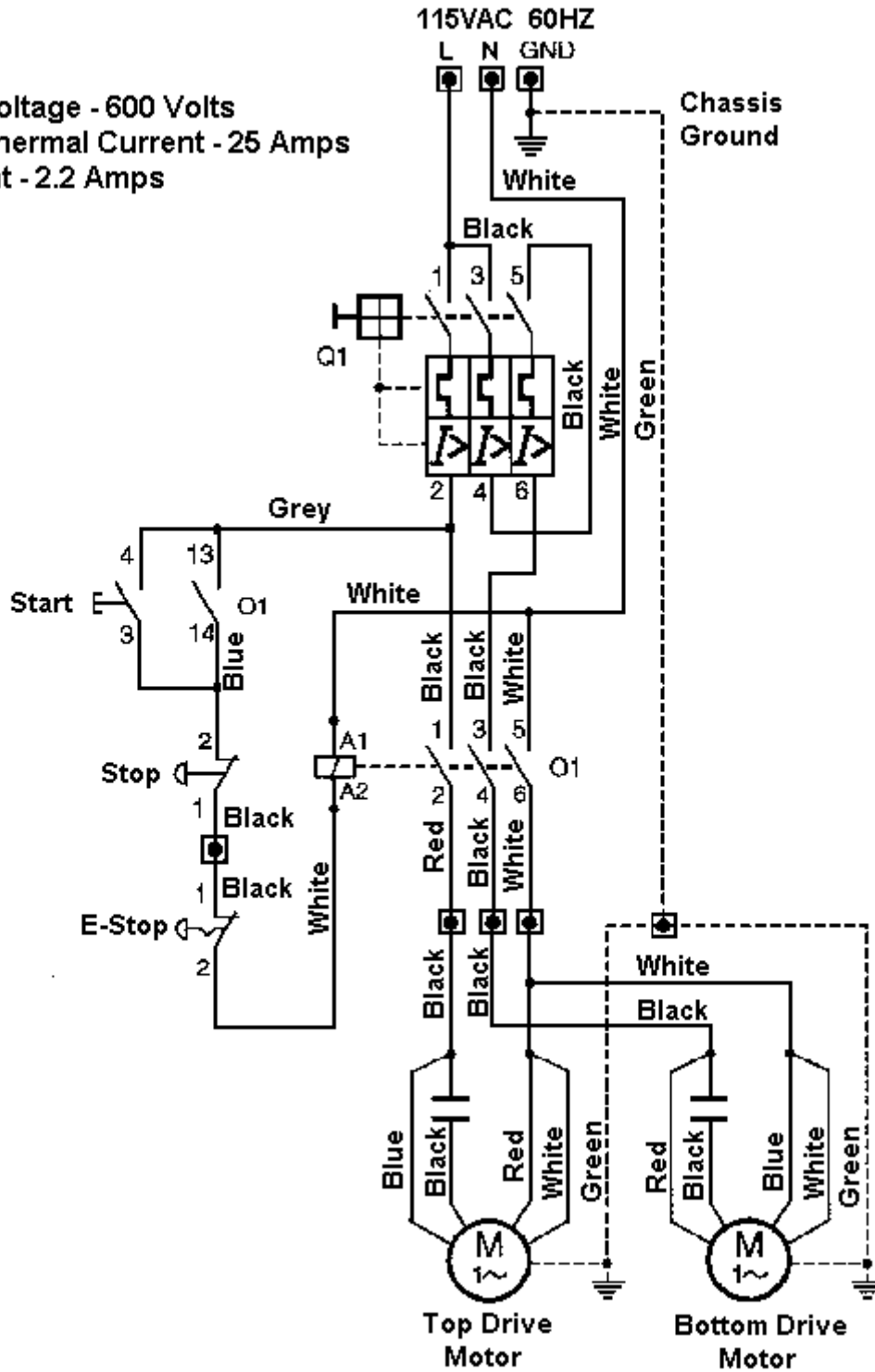

Pneumatic Diagram



WARNING

• To reduce the risk associated with mechanical and electrical hazards:

- Turn electrical and air supply off and disconnect before performing any adjustments, maintenance or servicing the machine or taping heads

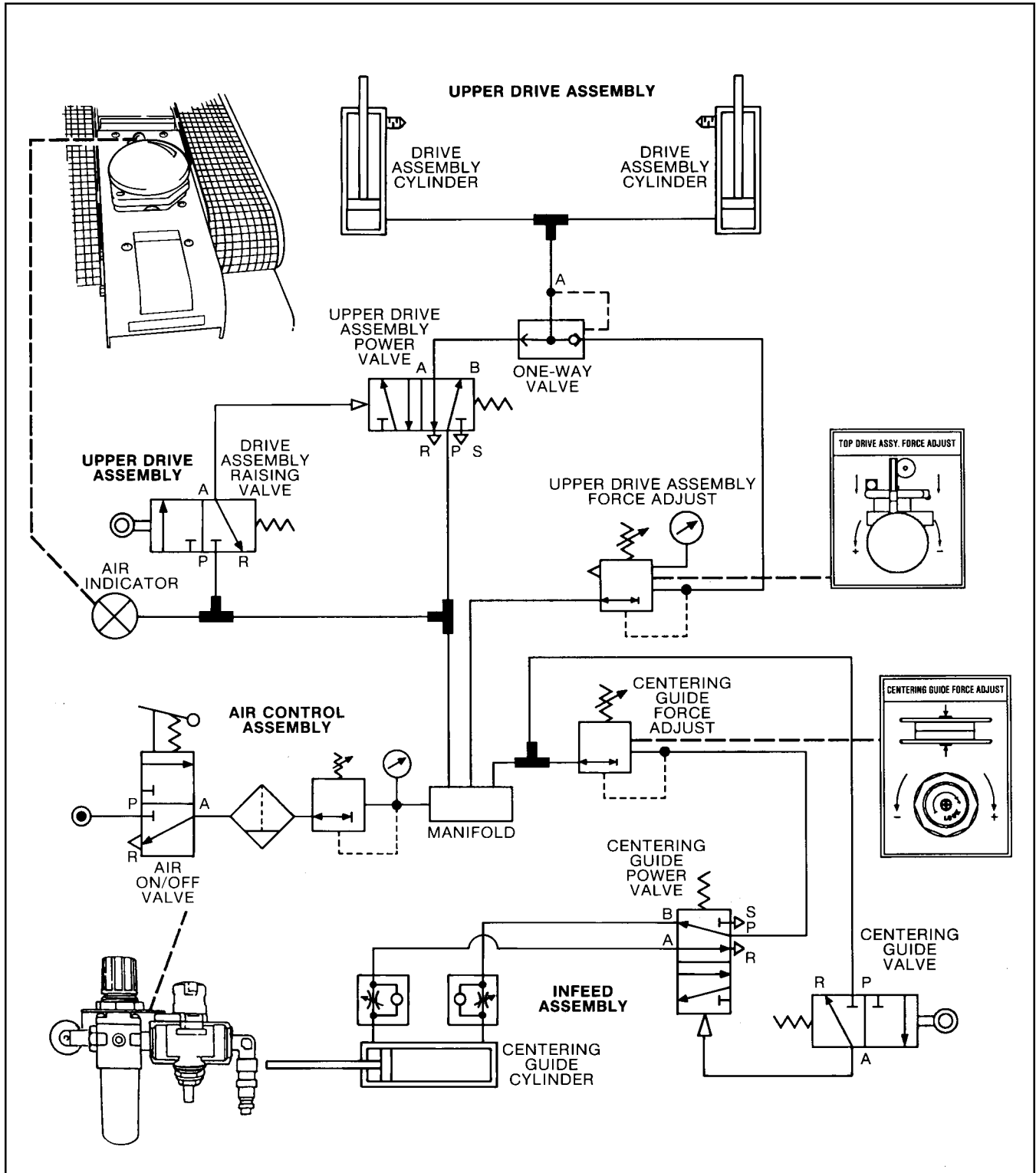

Figure 8-1 – Pneumatic Diagram

Replacement Parts And Service Information

Spare Parts

The following parts are normal wear items and should be ordered and kept on hand as used.

Qty.	Ref. No.	Part Number	Description
4	15010-43 & 15011-60	78-8070-1531-4	Belt – Drive W/Pin

In addition, a tool/spare parts kit supplied with the 700r3 Random Case Sealer contains the following spare parts:

Qty.	Ref. No.	Part Number	Description
1	10387-10 (Sec. II)	78-8070-1274-1	Spring – Upper Extension (Silver)
1	10389-10 (Sec. II)	78-8070-1273-3	Spring – Lower Extension (Black)
2	10391-2 (Sec. II)	78-8028-7899-7	Knife – 89 mm/3.5 Inch
4	10391-12 (Sec. II)	78-8052-6602-6	Spring – Cutter

All the above listed parts can be ordered separately and when used should be ordered and kept on hand for spares.

Also see Section II for recommended taping head spare parts.

Label Kit

In the event that any labels are damaged or destroyed, **they must be replaced to ensure operator safety.** A label kit, part number 78-8098-9177-9 is available as a stock item. It contains all the safety labels used on the

Tool Kit

A tool kit, part number 78-8076-4950-0, is supplied with the machine. The kit contains the necessary open end and hex socket wrenches for use with the metric fasteners on the case sealer. The threading tool, part number 78-8076-4726-4, contained in above kit is also available as a replacement stock item.

Replacement Parts Ordering Information and Service

Refer to the first page of this instruction manual "Replacement Parts and Service Information".

Options/Accessories

For additional information on the options/accessories listed below, contact your 3M Representative.

Part Number	Option/Accessory
78-8069-3983-7	Caster Kit Attachment
78-8069-3924-1	Conveyor Extension Attachment (exit only)
78-8069-3926-6	Low Tape Sensor Kit
70-0064-0355-7	AccuGlide 2+ STD 3 Inch Upper Taping Head, Type 10500
70-0064-0356-5	AccuGlide 2+ STD 3 Inch Lower Taping Head, Type 10500
78-8095-4852-8	3-Inch Tape Edge Fold Attachment, Upper Head
78-8095-4853-6	3-Inch Tape Edge Fold Attachment, Lower Head

THIS PAGE IS BLANK

Replacement Parts – Illustrations and Parts Lists

700r3 Random Case Sealer, Type 39600 Frame Assemblies

To Order Parts:

1. Refer to first illustration, **Frame Assemblies**, for the **Figure Number** that identifies a specific portion of the machine.
2. Refer to the appropriate **Figure or Figures** to determine the parts required and the parts reference number.
3. The Parts List that follows each illustration, includes the **Reference Number, Part Number** and **Part Description** for the parts on that illustration.

Note – The complete description has been included for standard fasteners and some commercially available components. This has been done to allow obtaining these standard parts locally, if desired.

4. Order parts by **Part Number, Part Description** and **Quantity** required. Also include machine name, number and type.
- 5.. Refer to the first page of this instruction manual “**Replacement Parts and Service Information**” for replacement parts ordering information.

IMPORTANT – Not all the parts listed are normally stocked items. Some parts or assemblies shown are available only on special order. Contact 3M/Tape Dispenser Parts to confirm item availability.

THIS PAGE IS BLANK

700r3 Random Case Sealer

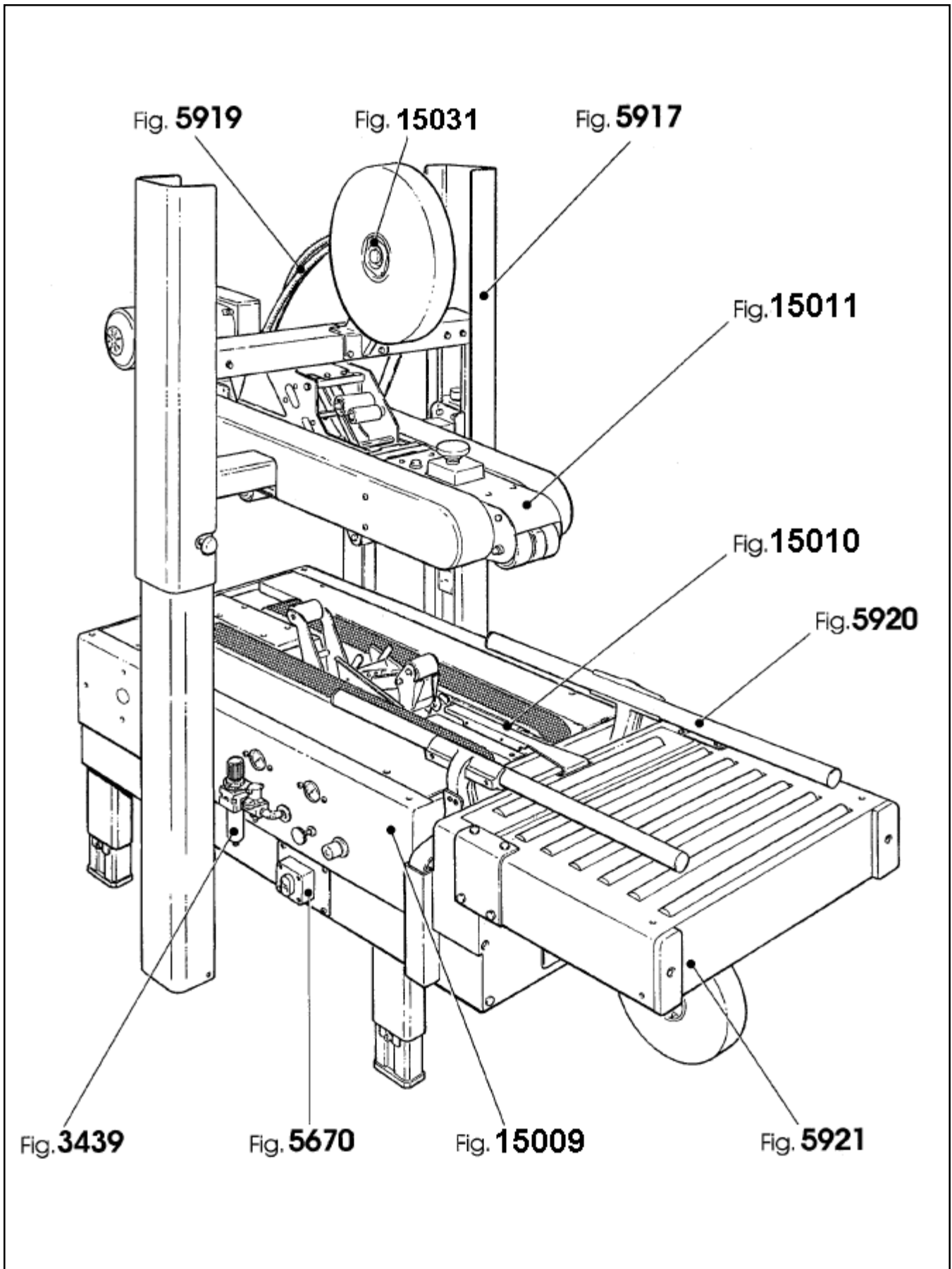

Frame Assemblies

700r3 Random Case Sealer

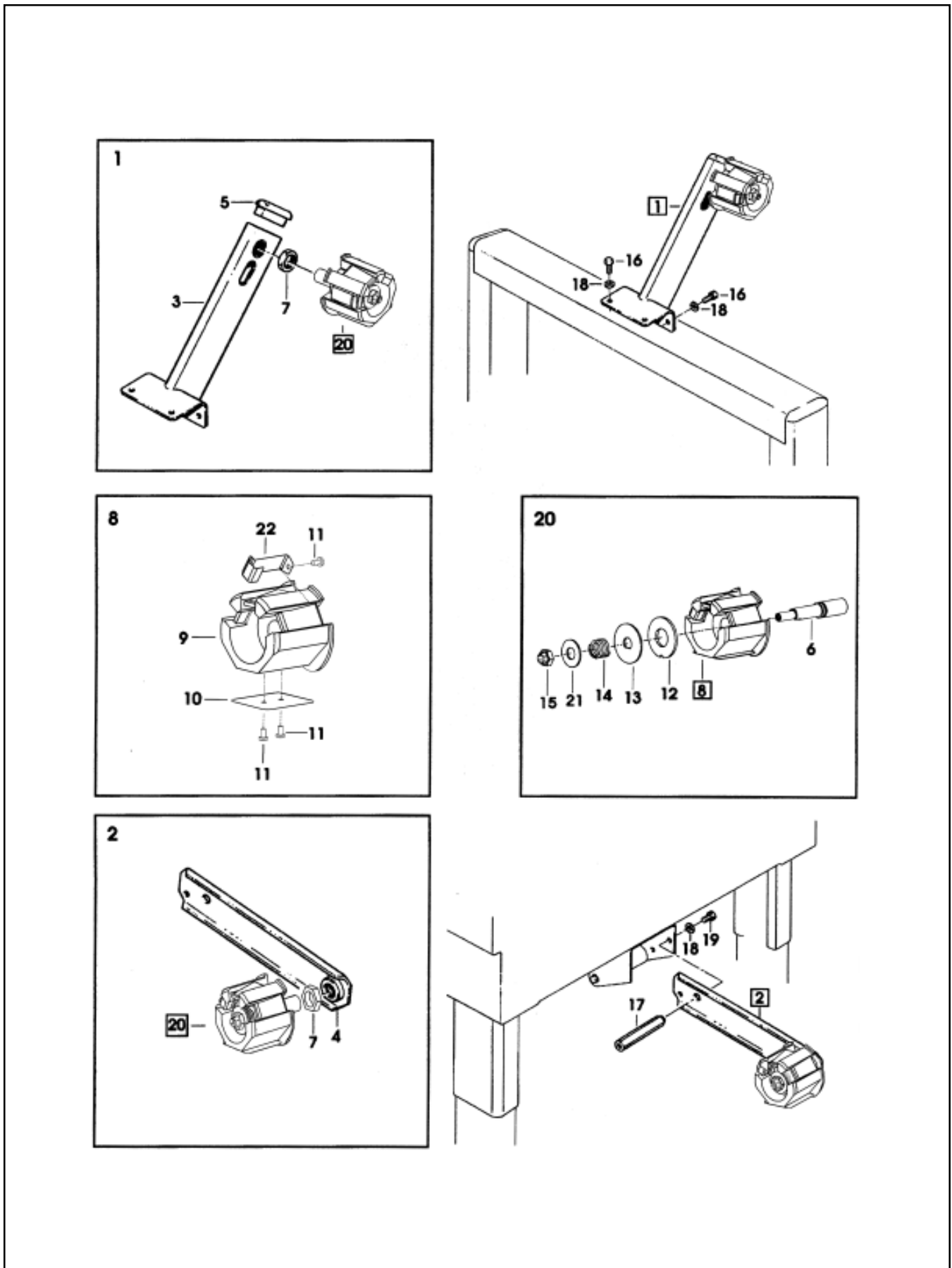

Figure 15031

Figure 15031

Ref. No.	3M Part No.	Description
10440-1	78-8137-1157-5	Tape Roll Bracket Assembly
15031-2	78-8137-1158-3	Tape Drum Bracket Assembly
15031-3	78-8070-1566-0	Bracket – Tape Drum
15031-4	78-8070-1395-4	Bracket – Bushing Assembly
15031-5	78-8070-1568-6	Cap – Bracket
15031-6	78-8060-8462-6	Shaft – Tape Drum, 3" Head
15031-7	78-8017-9169-6	Nut – M18 x 1
15031-8	78-8098-8829-6	Tape Drum Assembly – 3 Inch Wide
15031-9	78-8098-8828-8	Tape Drum
15031-10	78-8098-8830-4	Leaf Spring
15031-11	26-1002-5753-9	Screw – Self Tapping
15031-12	78-8060-8172-1	Washer – Friction
15031-13	78-8052-6271-0	Washer – Tape Drum
15031-14	78-8100-1048-4	Spring – Core Holder
15031-15	78-8017-9077-1	Nut – Self-Locking, M10 x 1
15031-16	78-8032-0375-7	Screw – Hex Hd M6 x 16
15031-17	78-8070-1215-4	Spacer – Stud
15031-18	26-1000-0010-3	Washer – Flat M6
15031-19	78-8010-7169-3	Screw – Hex Hd M6 x12
15031-20	78-8133-9641-9	Tape Drum Assembly – 3 Inch Head
15031-21	26-1004-5510-9	Washer – Plain, M10
15031-22	78-8097-8816-3	Latch - Tape Drum

700r3 Random Case Sealer

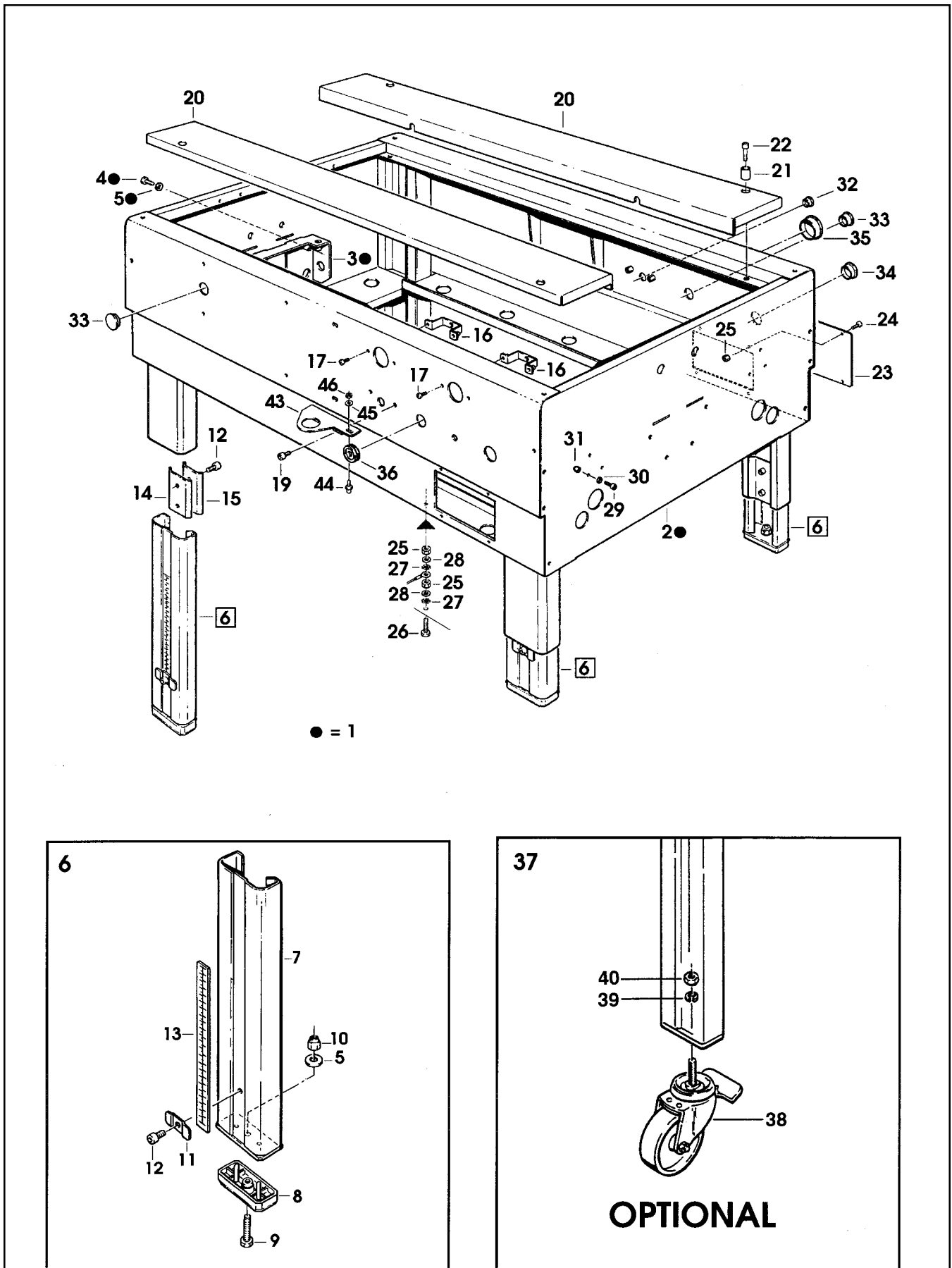

Figure 15009

Figure 15009

Ref. No.	3M Part No.	Description
15009-1	78-8091-0320-9	Conveyor Bed Assembly
15009-2	78-8091-0321-7	Bed – Conveyor
15009-3	78-8091-0307-6	Support – Drive
15009-4	26-1003-5842-8	Screw – Hex Hd, M8 x 20
15009-5	78-8017-9318-9	Washer – Plain, 8 mm
15009-6	78-8076-5381-7	Leg Assembly – Inner, W/Stop
15009-7	78-8076-5382-5	Leg – Inner
15009-8	78-8060-8480-8	Pad – Foot
15009-9	78-8055-0867-4	Screw – Hex Hd, M8 x 30
15009-10	78-8017-9313-0	Nut – Self Locking, M8
15009-11	78-8076-5383-3	Stop – Leg
15009-12	26-1003-7963-0	Screw – Soc Hd, M8 x 16
15009-13	78-8060-8481-6	Label – Height
15009-14	78-8052-6677-8	Clamp – Inner
15009-15	78-8052-6676-0	Clamp – Outer
15009-16	78-8076-4535-9	Bracket
15009-17	78-8076-4625-8	Screw – Special, M5 x 16
15009-19	78-8010-7209-7	Screw – Soc Hd, M6 x 12
15009-20	78-8137-0543-7	Plane – Conveyor Bed, L/H W/English Label
	78-8137-0585-8	Plane – Conveyor Bed, R/H W/English Label
15009-21	78-8060-8486-5	Bushing
15009-22	78-8010-7211-3	Screw – Soc Hd, M6 x 25
15009-23	78-8060-8487-3	Cover – Switch
15009-24	78-8060-8087-1	Screw – M5 x 10
15009-25	78-8010-7417-6	Nut – M5
15009-26	78-8060-8488-1	Screw – Hex Hd, M5 x 20
15009-27	78-8046-8217-3	Washer – Special
15009-28	78-8005-5741-1	Washer – Plain, M5
15009-29	78-8076-4537-5	Screw – Soc Hd, M3 x 25
15009-30	78-8076-4538-3	Washer – Flat, M3
15009-31	78-8059-5517-2	Nut – Self Locking, M3
15009-32	78-8076-4517-7	End Cap – /22 x 1
15009-33	78-8076-4701-7	Cap – /28
15009-34	78-8060-8184-6	Cap – /35 x 1,5
15009-35	78-8076-4536-7	Cap – /45 x 1,5
15009-36	78-8076-4702-5	Grommet – /28
15009-37	78-8098-9076-3	Caster Assembly
15009-38	26-1009-9096-4	Caster – Dual Locking
15009-39	26-1009-9094-9	Washer – Spring Helical, M12
15009-40	26-1009-9095-6	Nut – M12
15009-43	78-8091-0717-6	Support – R/H, Filter Assembly
	78-8091-0612-9	Support - L/H, Filter Assembly (Not Shown)
15009-44	78-8091-0613-7	Shaft – Valve
15009-45	26-1000-0010-3	Washer – Flat, M6
15009-46	78-8010-7418-4	Nut – Hex, M6
15009-43	78-8091-0717-6	Support – R/H, Filter Assembly
15009-44	78-8091-0613-7	Shaft – Valve
15009-45	26-1000-0010-3	Washer – Flat, M6
15009-46	78-8010-7418-4	Nut – Hex, M6

700r3 Random Case Sealer

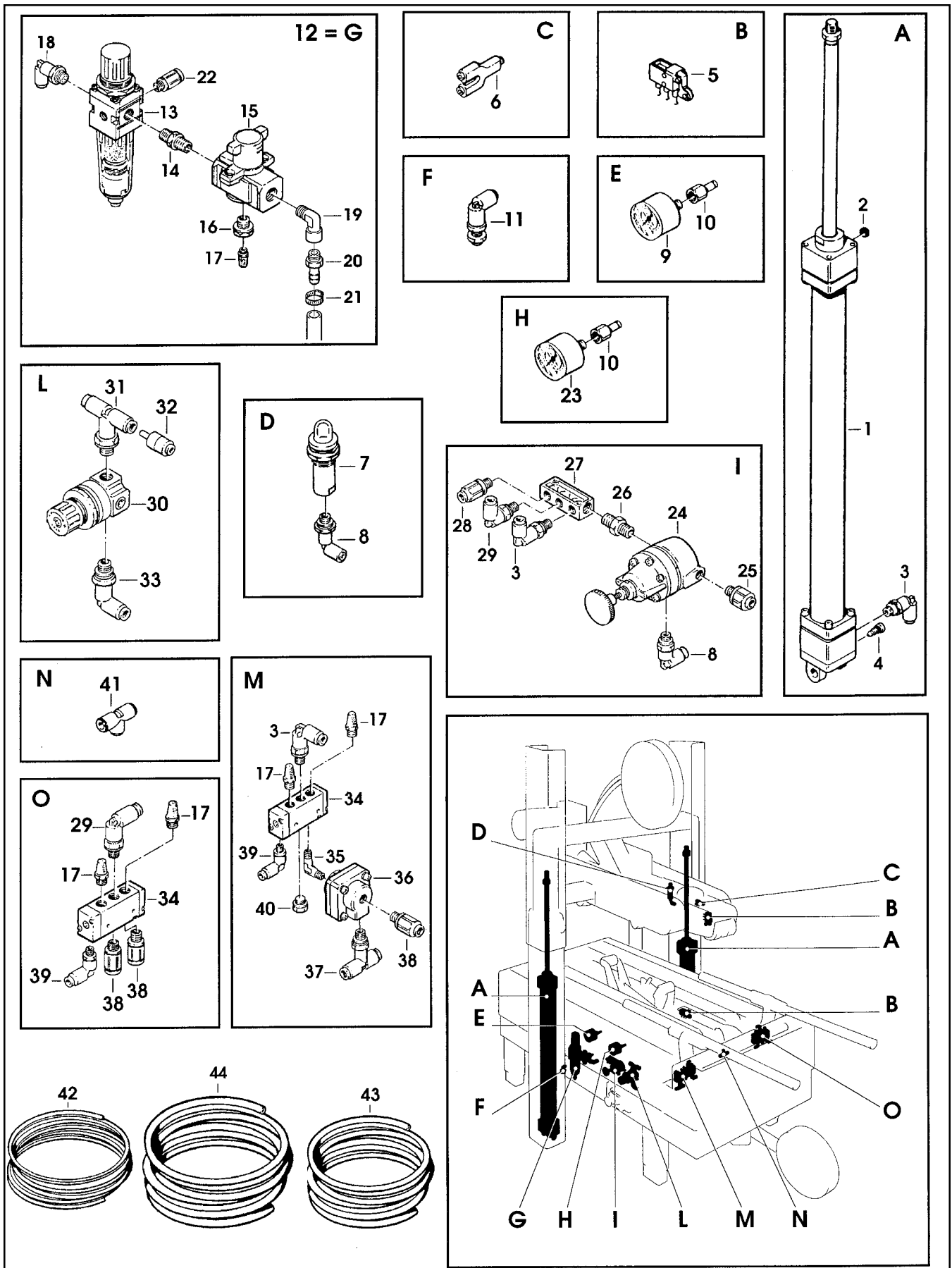

Figure 3439

Figure 3439

Ref. No.	3M Part No.	Description
3439-1	78-8076-4663-9	Cylinder – Air /32 x 580 + 20
3439-2	78-8094-6457-7	Cap – 1/8 Inch
3439-3	78-8091-0313-4	Elbow – 3199.08.10
3439-4	78-8076-4680-3	Screw – Cushioning, Cyl/32
3439-5	78-8060-8091-3	Valve – R/O-3-PK-3
3439-6	78-8076-4664-7	Union – Female
3439-7	78-8076-4665-4	Indicator – Visual
3439-8	26-1005-5909-0	Elbow
3439-9	78-8054-8838-0	Gauge – Air
3439-10	78-8076-4672-0	Union – Straight, Female
3439-11	78-8091-0350-6	Union – Special
3439-12	78-8091-0314-2	Filter – EAW 2000, W/O Gage
3439-13	26-1014-4558-8	Filter – Regulator, W/Metal Bowl
3439-14	78-8060-7899-0	Nipple – RA 012 1/4 - 1/4
3439-15	78-8076-4669-6	Valve – On/Off
3439-16	78-8076-4670-4	Reduction – 3/8 - 1/8
3439-17	26-1005-6890-1	Muffler
3439-18	78-8091-0315-9	Elbow – 3199.08.13
3439-19	78-8060-7900-6	Union – RA 002 1/4 - 1/4
3439-20	26-1005-6897-6	Hose Connector
3439-21	78-8091-0430-6	Clamp – /14-24
3439-22	78-8060-7853-7	Union – Straight MR12-04-18
3439-23	78-8076-4671-2	Gauge – Pressure
3439-24	78-8076-4673-8	Regulator – Pressure
3439-25	26-1005-6901-6	Union – Straight
3439-26	78-8076-4674-6	Nipple – 1/4 - 1/8
3439-27	78-8059-5633-7	Air Distributor
3439-28	78-8091-0316-7	Union – Straight, 3101.08.10
3439-29	26-1005-6893-5	Elbow – 90°
3439-30	78-8076-4675-3	Regulator – 0,5-7 Bar
3439-31	78-8076-4676-1	Union
3439-32	78-8057-5735-4	Fitting – Reducer MR25-04-06
3439-33	78-8055-0756-9	Union – Rotating MR41-06-14
3439-34	78-8076-4677-9	Valve – V2A 5120-01
3439-35	78-8017-9426-0	Elbow – 90°, 1/8 M x 1/8 M
3439-36	78-8076-4678-7	Valve – One-Way
3439-37	78-8091-0317-5	Union – Tee, 3198.08.10
3439-38	26-1005-6910-7	Union – Straight
3439-39	78-8057-5732-1	Fitting – Elbow MR41-04-05
3439-40	78-8060-7690-3	Cap – B-1/8
3439-41	78-8076-4679-5	Union – Tee
3439-42	78-8119-8666-6	Tube – Air, 4 mm O.D. x 2.5 mm I.D.
3439-43	78-8119-8667-4	Tube – Air, 6 mm O.D. x 4 mm I.D.
3439-44	78-8119-8668-2	Tube – Air, 8 mm O.D. x 5 mm I.D.
3439	78-8060-8175-4	Repair Kit for Cylinder /32

700r3 Random Case Sealer

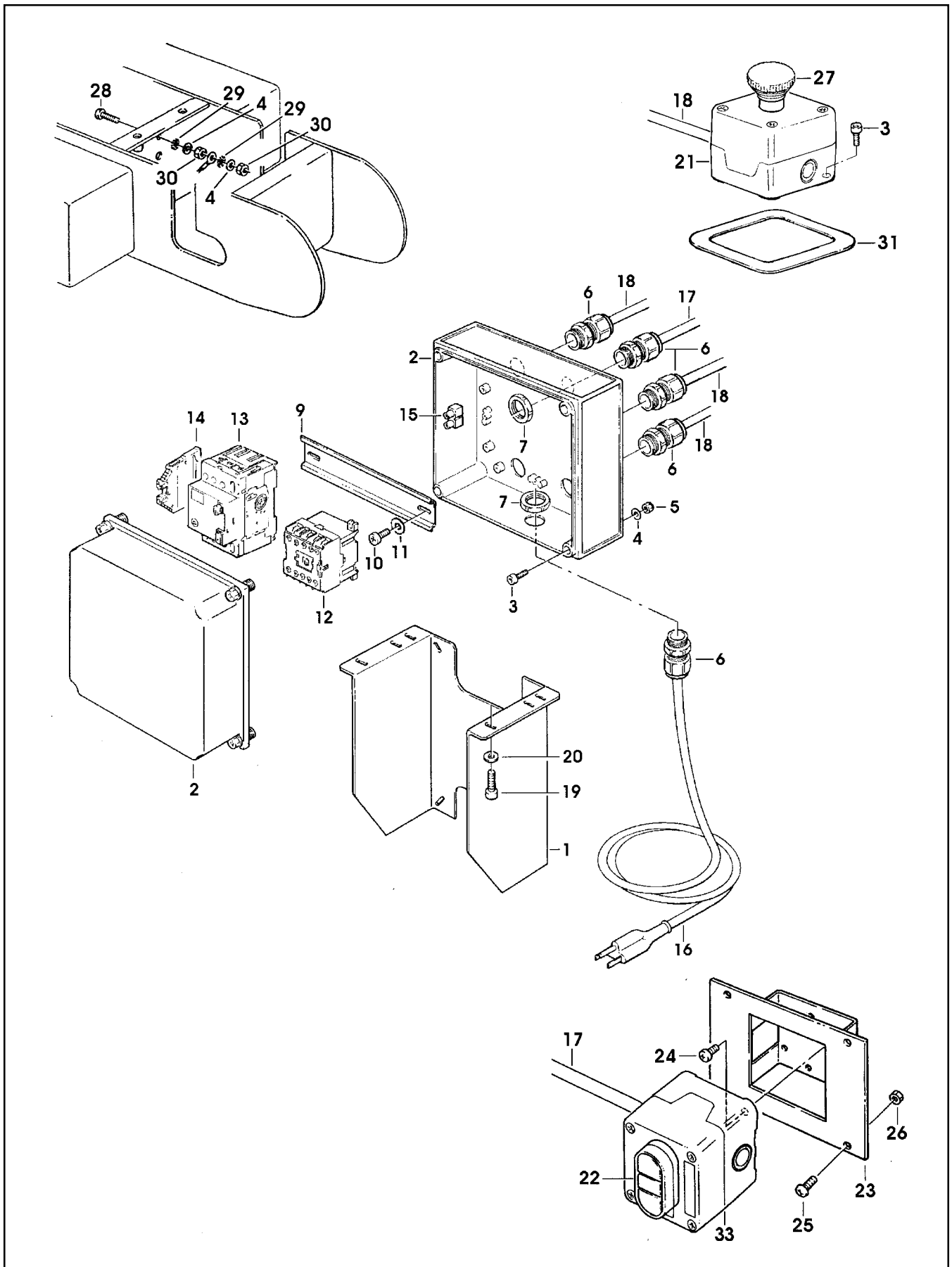

Figure 5670

Figure 5670

Ref. No.	3M Part No.	Description
5670-1	78-8094-6379-3	Support – Box
5670-2	78-8113-6759-4	Box – W/English Language Label
5670-3	78-8094-6381-9	Screw – Soc Hd, Hex Hd, M4 x 15
5670-4	78-8005-5740-3	Washer – Plain, 4 mm
5670-5	26-1003-6914-4	Nut – Plastic Insert, M4
5670-6	78-8076-4715-7	Cord Grip
5670-7	78-8076-5211-6	Set Nut – GMP 13.5
5670-9	78-8094-6382-7	Guide – Mounting
5670-10	78-8028-8208-0	Screw – 6Px9,5
5670-11	78-8017-9018-5	Washer – Plain, M4
5670-12	78-8094-6383-5	Contactactor – CA4-5-10, 110V, 60Hz
5670-13	78-8076-5378-3	Switch – Thermal, KTA-3-25
5670-14	78-8094-6384-3	Clamp – VGPE 4/6
5670-15	78-8076-4968-2	Terminal
5670-16	78-8028-7909-4	Power Cord – U.S.A.
5670-17	78-8100-1038-5	Cable – 4 x 20 AWG, 5 MT
5670-18	78-8060-8053-3	Wire – 3-Pole, 5 Meters Length
5670-19	26-1003-7957-2	Screw – Soc Hd Hex, M6 x 16
5670-20	26-1000-0010-3	Washer – Flat, M6
5670-21	78-8076-5194-4	Box – E-Stop
5670-22	78-8094-6386-8	Switch – On/Off, DM3N-C-01/10 (pushbutton and 1 N.O., 1 N.C. contact block)
5670-23	78-8113-6887-3	Support – On/Off Switch, w/English Language Label
5670-24	78-8017-9257-9	Screw – Phil Hd, M4 x 10
5670-25	78-8060-8087-1	Screw – M5 x 10
5670-26	78-8010-7417-6	Nut – Hex, M5
5670-27	26-1014-5845-8	E-Stop – 800EM-MTS44-3LX01
5670-28	78-8091-0538-6	Screw – Hex Hd, M4 x 20
5670-29	78-8076-4716-5	Star Washer – M4
5670-30	78-8010-7416-8	Nut – Hex, M4
5670-31	78-8100-1234-0	Bezel
5670-33	78-8114-4896-4	Box – On/Off, Grey

700r3 Random Case Sealer

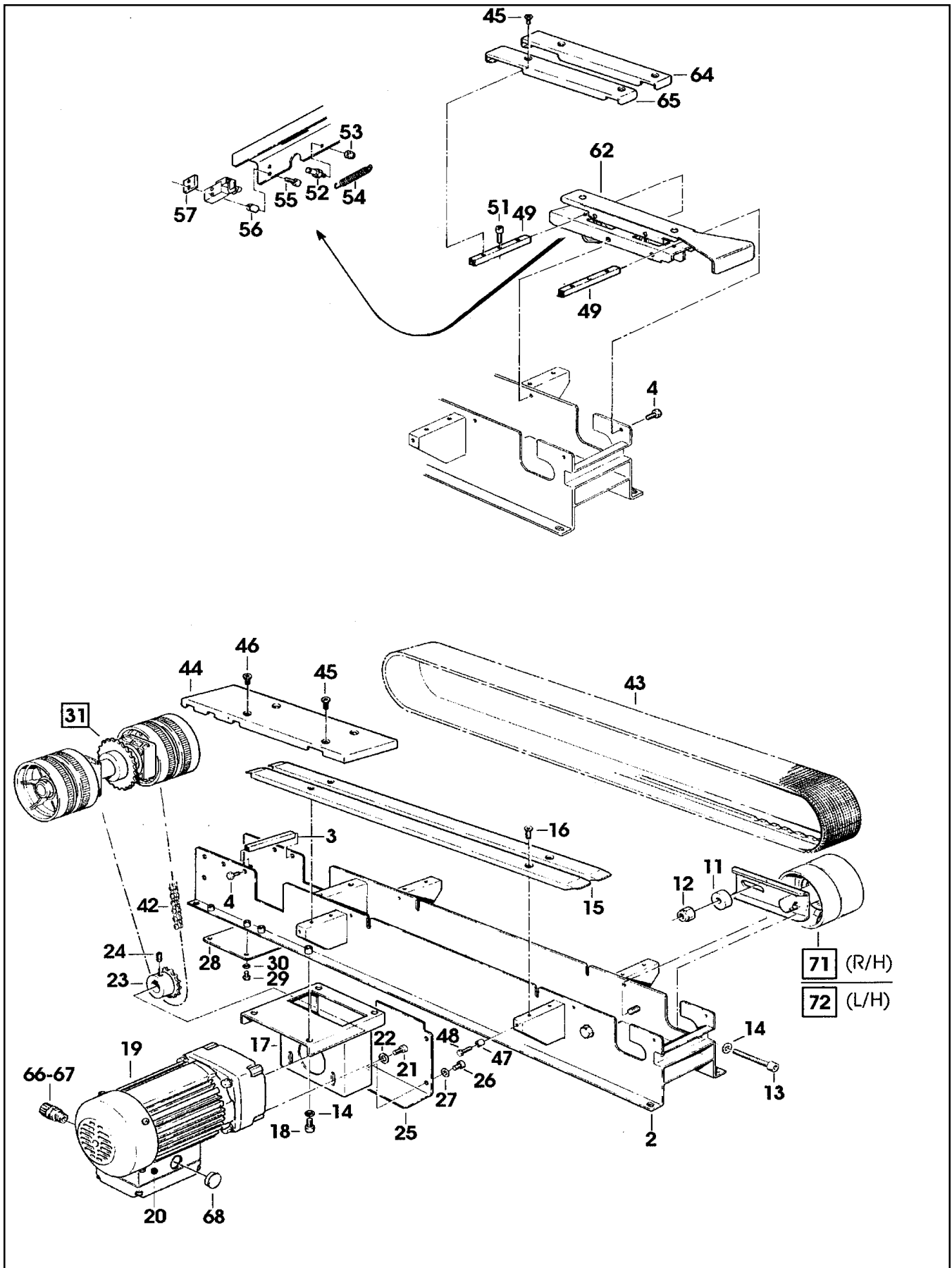

Figure 15010/1 of 2

Figure 15010 (Page 1 of 2)

Ref. No.	3M Part No.	Description
15010-1	78-8137-0587-4	Bottom Drive Assembly – W/O Motor
15010-2	78-8137-0588-2	Frame – Drive
15010-3	78-8137-0568-4	Spacer
15010-4	26-1003-5829-5	Screw – Hex Hd, M6 x 12
15010-7	78-8052-6710-7	Roller – Idler
15010-8	78-8052-6709-9	Washer – Special
15010-9	78-8010-7435-8	Washer – Lock, M6
15010-10	26-1003-7957-2	Screw – Soc Hd Hex Hd, M6 x 16
15010-11	78-8070-1518-1	Spacer – Shaft
15010-12	26-1003-6918-5	Nut – Plastic Insert, Hex Flange, M10
15010-13	78-8070-1519-9	Screw – Soc Hd Hex Hd, M8 x 70
15010-14	78-8017-9318-9	Washer – Plain, 8 mm
15010-15	78-8070-1520-7	Guide – Drive Belt
15010-16	26-1005-4757-4	Screw – Flat Hd, Soc Dr, M5 x 20
15010-17	78-8137-0569-2	Support – Gearbox
15010-18	26-1003-7964-8	Screw – Soc Hd, Hex Soc Dr, M8 x 20
15010-19	78-8070-1522-3	Gearmotor – 115V, 60HZ
15010-20	26-1011-8828-7	Capacitor – 115V Gearmotor
15010-21	78-8070-1523-1	Screw – 1/4 - 28 X 1/2 SHCS
5915-22	78-8042-2919-9	Washer – Triple, M6
15010-23	78-8070-1524-9	Sprocket – 3/8 Z=17
15010-24	78-8023-2479-4	Screw – Set W/End Cup, M6 x 10
15010-25	78-8070-1526-4	Cover – Chain
15010-26	78-8010-7209-7	Screw – Soc Hd, M6 x 12
15010-27	26-1000-0010-3	Washer – Flat, M6
15010-28	78-8076-4562-3	Cover – Bottom
15010-29	26-1003-5820-4	Screw – Hex Hd, M5 x 12
15010-30	78-8005-5741-1	Washer – Flat, M5
15010-31	78-8137-0570-0	Shaft With Drive Pulleys
15010-32	78-8137-0537-9	Shaft – Gearbox
15010-33	78-8057-5811-3	Key – 6 x 6 x 20 mm
15010-34	78-8054-8986-7	Sprocket – 3/8 Pitch, 28 Teeth
15010-35	78-8054-8984-2	Bushing
15010-36	78-8070-1529-8	Support – Shaft
15010-37	78-8070-1530-6	Bearing – 6205-2RS
15010-38	78-8057-5739-6	Key – M5 x 5 x 30 mm
15010-39	78-8076-5105-0	Pulley Assembly Drive

700r3 Random Case Sealer

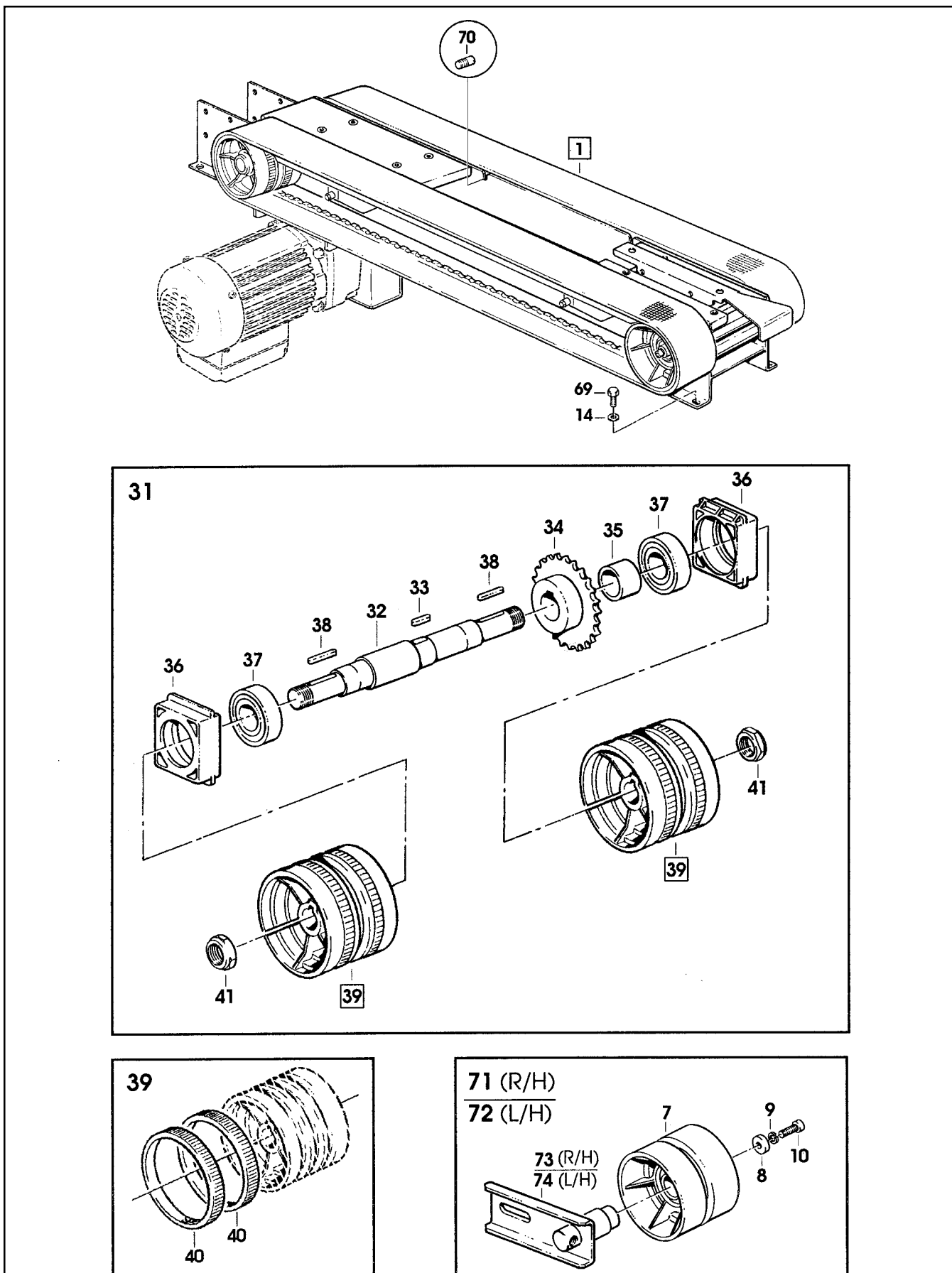

Figure 15010/2 of 2

Figure 15010 (Page 2 of 2)

Ref. No.	3M Part No.	Description
15010-40	78-8052-6713-1	Ring – Polyurethane
15010-41	78-8060-8416-2	Nut – Special, M20 x 1
15010-42	78-8070-1525-6	Chain – 3/8 Inch P=54
15010-43	78-8070-1531-4	Belt – Drive With Hook
15010-44	78-8137-0546-0	Cover – Drive, Rear
15010-45	26-0001-5862-1	Screw – Flat Hd Soc, M5 x 12
15010-46	26-1005-5316-8	Screw – Flat Hd Hex Dr, M5 x 16
15010-47	78-8070-1534-8	Stud – Side Plate
15010-48	78-8060-8488-1	Screw – Hex Hd, M5 x 20
15010-49	78-8137-0563-5	Spacer
15010-51	26-1003-7951-5	Screw – Soc Hd Hex Soc, M5 x 20
15010-52	78-8054-8757-2	Pin – Spring Holder
15010-53	26-1005-6859-6	Nut – Self Locking, M5
15010-54	78-8076-4774-4	Spring
15010-55	26-1003-7947-3	Screw – Soc Hd Hex Soc, M4 x 35
15010-56	78-8054-8758-0	Spacer – Valve Holder
15010-57	78-8059-5607-1	Plate – Threaded
15010-62	78-8134-2328-8	Actuator – Side Guide
15010-64	78-8137-0557-7	Cover – Right
15010-65	78-8137-0557-7	Cover – Left
15010-66	78-8076-4715-7	Cord Grip
15010-67	78-8076-5211-6	Set Nut – GMP 13,5
15010-68	78-8060-7885-9	End Cap – /25x1,2
15010-69	26-1003-5841-0	Screw – M8 x 16
15010-70	78-8076-4500-3	Stud – Mounting
15010-71	78-8100-1236-5	Belt Tensioning Assembly – R/H
15010-72	78-8100-1237-3	Belt Tensioning Assembly – L/H
15010-73	78-8100-1238-1	Belt Tensioning – R/H
15010-74	78-8100-1239-9	Belt Tensioning – L/H

700r3 Random Case Sealer

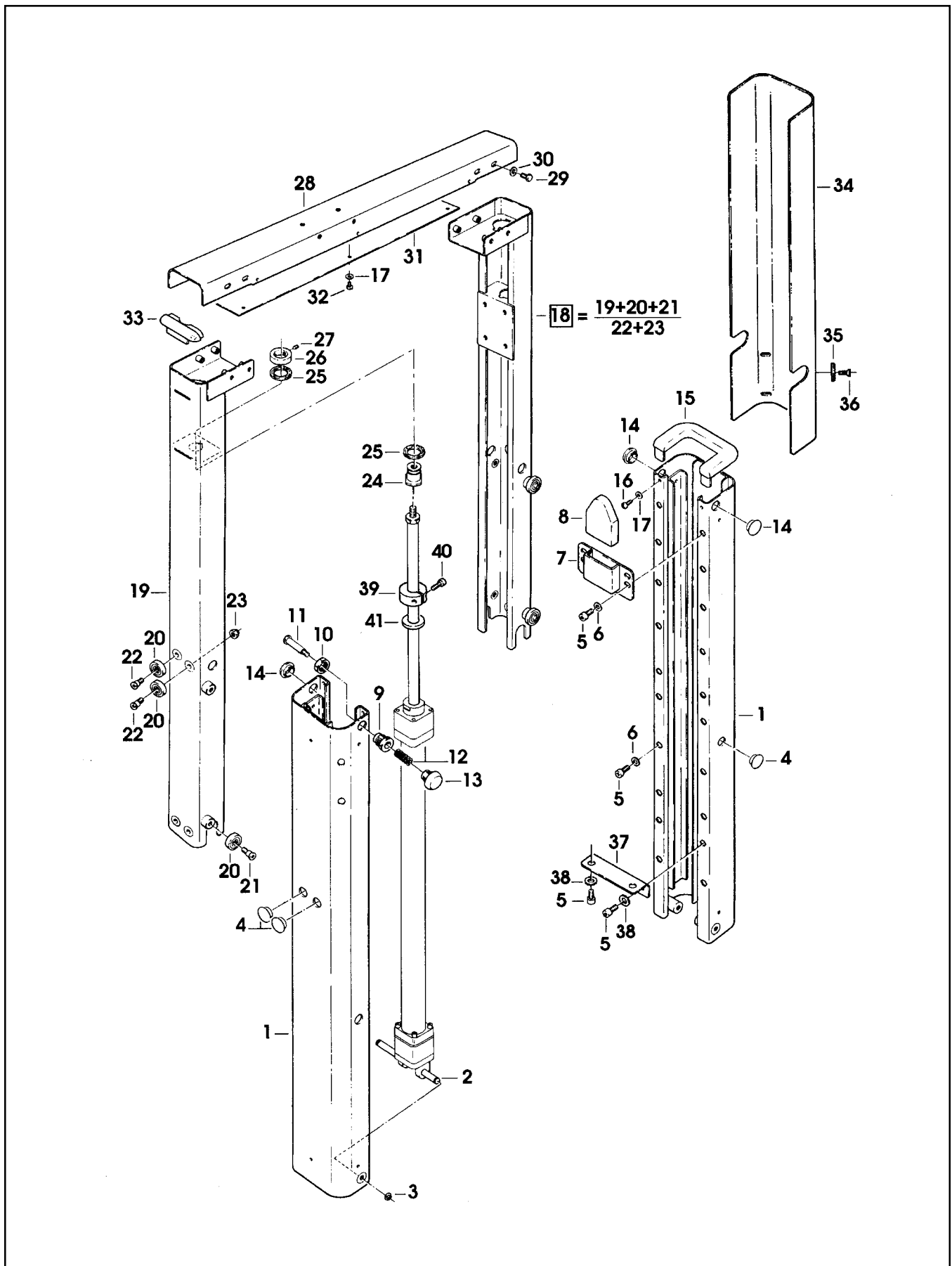

Figure 5917

Figure 5917

Ref. No.	3M Part No.	Description
5917-1	78-8076-4539-1	Column – Outer
5917-2	78-8076-4540-9	Pin – Air Cylinder
5917-3	78-8060-8035-0	E-Ring – 7DIN6799
5917-4	78-8054-8821-6	End – Cap
5917-5	26-1003-7964-8	Screw – Soc Hd Hex Soc Dr, M8 x 20
5917-6	78-8017-9318-9	Washer – Plain 8 mm
5917-7	78-8076-4541-7	Plate – Bumper Support
5917-8	78-8076-4542-5	Bumper
5917-9	78-8076-4543-3	Bushing – Height Stop
5917-10	78-8017-9169-6	Nut – M18 x 1
5917-11	78-8076-4544-1	Stud – Height Stop
5917-12	78-8076-4545-8	Spring
5917-13	78-8100-0954-4	Knob
5917-14	78-8076-4547-4	Cap – /18
5917-15	78-8060-8491-5	Cap – Column
5917-16	78-8076-4548-2	Screw – Self Tapping, 8P x 16
5917-17	78-8005-5740-3	Washer – Plain 4 mm
5917-18	78-8076-4549-0	Column Assembly – Inner
5917-19	78-8076-4550-8	Column – Inner
5917-20	78-8054-8617-8	Bearing – Special
5917-21	78-8017-9106-8	Screw – Bearing Shoulder
5917-22	78-8054-8589-9	Screw – Special
5917-23	26-1003-6916-9	Nut – Locking Plastic Insert, M6
5917-24	78-8076-4551-6	Mounting – Rod
5917-25	78-8054-8823-2	Washer – Bumper
5917-26	78-8076-4552-4	Ring Nut – Rod
5917-27	78-8059-5617-0	Set Screw – M6 x 8
5917-28	78-8076-4553-2	Crossmember
5917-29	78-8060-7886-7	Screw – Hex Hd, M6 x 16 Special
5917-30	26-1000-0010-3	Washer – Flat, M6
5917-31	78-8070-1504-1	Cover
5917-32	78-8010-7157-8	Screw – Hex Hd, M4 x 10
5917-33	78-8070-1505-8	Cap – Inner Column
5917-34	78-8113-6886-5	Guard – Column, W/English Language Label
5917-35	78-8076-5477-3	Washer – Special
5917-36	26-1001-9843-6	Screw – Flat Soc Hd, M6 x 16
5917-37	78-8060-8490-7	Plate – Column Mounting
5917-38	26-1004-5507-5	Washer – M8
5917-39	78-8100-1153-2	Collar – Height Locking
5917-40	78-8010-7210-5	Screw – Soc Hd Hex Soc, M6 x 20
5917-41	78-8100-1154-0	Washer – /30-15-05

700r3 Random Case Sealer

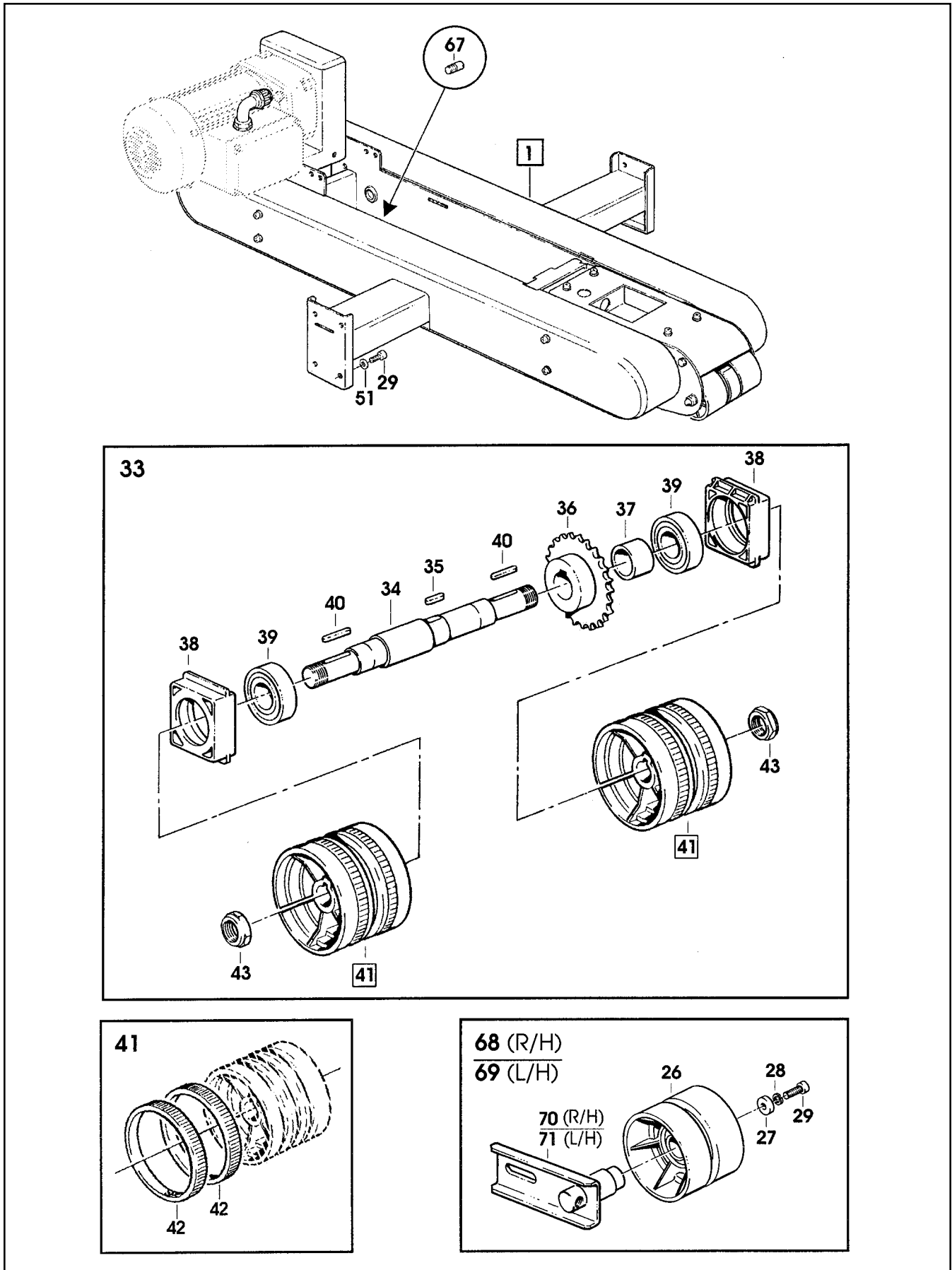

Figure 15011/1 of 2

Figure 15011 (Page 1 of 2)

Ref. No.	3M Part No.	Description
15011-1	78-8137-0589-0	Upper Drive Assembly – W /O Motor
15011-2	78-8137-0590-8	Frame – Drive, Upper
15011-3	78-8070-1520-7	Guide – Drive Belt
15011-4	26-1005-4757-4	Screw – Flat Hd, M5 x 20
15011-5	78-8137-0533-8	Clamp – Upper Head
15011-6	78-8137-0534-6	Shaft – Roller
15011-7	26-1003-7948-1	Screw – Soc Hd, M5 x 10
15011-8	78-8137-0521-3	Spacer – Valve
15011-9	78-8010-7169-3	Screw – Hex Hd, M6 x 12
15011-10	26-1000-0010-3	Washer – Flat, M6
15011-11	78-8137-0536-1	Tube – Roller
15011-12	78-8052-6641-4	Roller
15011-13	78-8076-4657-1	Link – Actuator, Valve
15011-14	78-8137-0535-3	Shaft – Roller
15011-15	78-8100-1132-6	Nut – Special, M8
15011-16	78-8017-9318-9	Washer – Plain, 8 mm
15011-17	78-8137-0591-6	Shaft
15011-18	78-8052-6566-3	Washer – Friction
15011-19	78-8016-5855-6	E-Ring – 100 mm
15011-20	78-8076-4659-7	Plate – Valve
15011-21	78-8010-7163-6	Screw – Hex Hd, M5 x 10
15011-22	26-1003-7946-5	Screw – Soc Hd, M4 x 25
15011-23	78-8059-5607-1	Plate – Threaded
15011-26	78-8052-6710-7	Roller – Idler
15011-27	78-8052-6709-9	Washer – Special
15011-28	78-8010-7435-8	Washer – Lock, M6
15011-29	26-1003-7957-2	Screw – Soc Hd, M6 x 16
15011-30	78-8070-1518-1	Spacer – Shaft
15011-31	26-1003-6918-5	Nut – Hex, Plastic Insert, M10
15011-32	78-8070-1594-2	Screw – Hex Hd, M8 x 60
15011-33	78-8137-0570-0	Shaft – With Drive Pulleys
15011-34	78-8137-0537-9	Shaft – Gearbox
15011-35	78-8057-5811-3	Key – 6 x 6 x 20 mm
15011-36	78-8054-8986-7	Sprocket – 3/8" Pitch 28 Teeth
15011-37	78-8054-8984-2	Bushing

700r3 Random Case Sealer

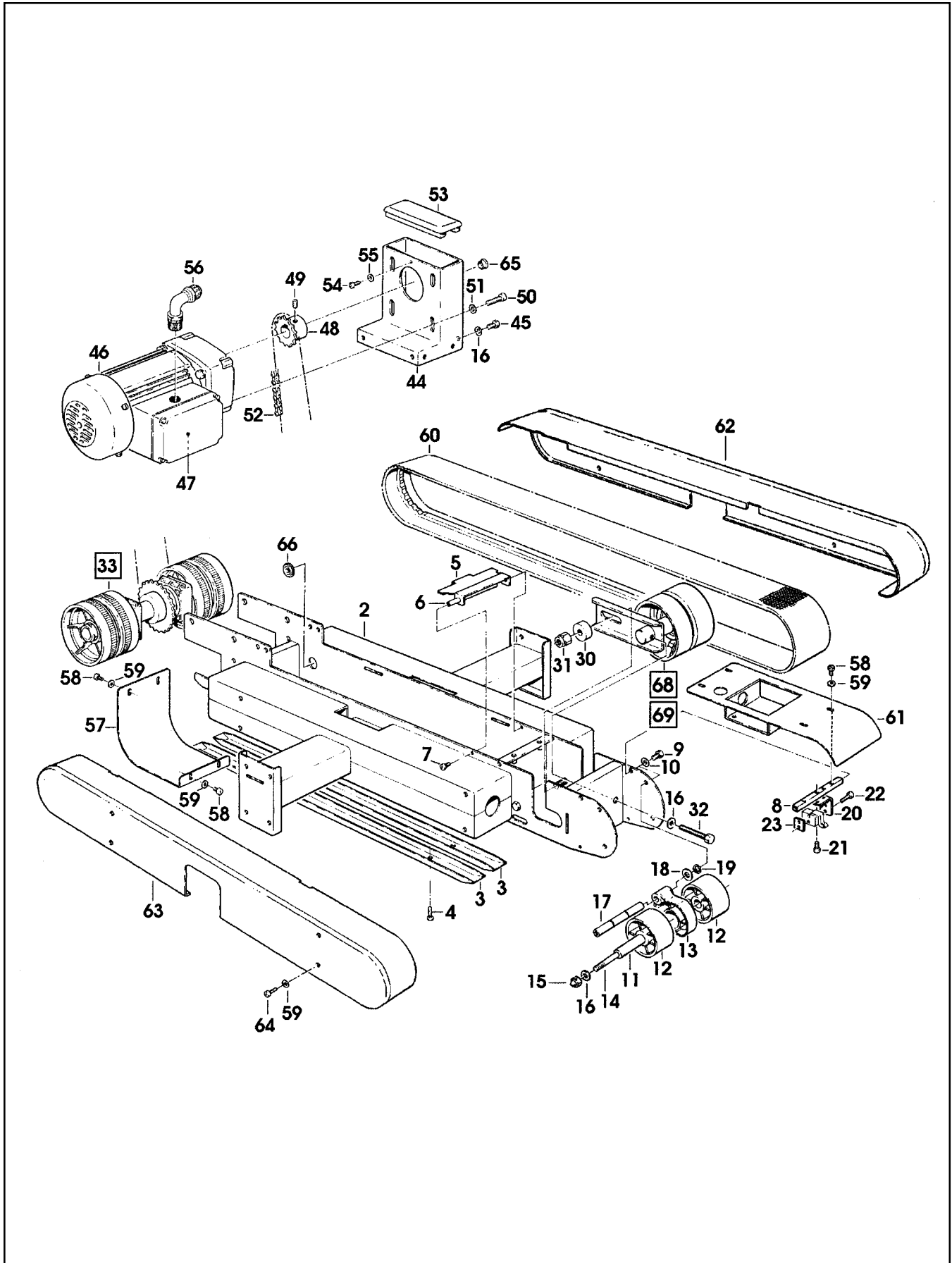

Figure 15011/2 of 2

Figure 15011 (Page 2 of 2)

Ref. No.	3M Part No.	Description
15011-38	78-8070-1529-8	Support – Shaft
15011-39	78-8070-1530-6	Bearing – 6205-2RS
15011-40	78-8057-5739-6	Key – M5 x 5 x 30 mm
15011-41	78-8076-5105-0	Pulley Assembly – Drive
15011-42	78-8052-6713-1	Ring – Polyurethane
15011-43	78-8060-8416-2	Nut – Special, M20 x 1
15011-44	78-8137-0582-5	Support – Drive
15011-45	26-1003-5842-8	Screw – Hex Hd, M8 x 20
15011-46	78-8070-1522-3	Gearmotor – 115V, 60HZ
15011-47	78-8076-4515-1	Capacitor – 115V Gearmotor
15011-48	78-8070-1524-9	Sprocket – 3/8" Z=17
15011-49	78-8023-2479-4	Set Screw – W/End Cup, M6 x 10
15011-50	78-8070-1523-1	Screw – 1/4-28 x 1/2 SHCS
15011-51	78-8100-1042-7	Washer – /15 x 6.35 x 2
15011-52	78-8070-1597-5	Chain – 3/8" P=62
15011-53	78-8070-1598-3	Cover
15011-54	26-1002-4955-1	Screw – Self Tap 8P x 13
15011-55	78-8005-5740-3	Washer – Plain, 4 mm
15011-56	78-8070-1596-7	Union – Elbow, PG 13,5
15011-57	78-8137-0575-9	Cover – Rear Upper
15011-58	78-8060-8087-1	Screw – M5 x 10
15011-59	78-8005-5741-1	Washer – Flat, M5
15011-60	78-8070-1531-4	Belt – Drive, W/Hook
15011-61	78-8137-0592-4	Cover – Upper, Front, W/English Language Label
15011-62	78-8113-6889-9	Guard – Belt, R/H, W/English Language Label
15011-63	78-8113-6888-1	Guard – Belt, L/H, W/English Language Label
15011-64	78-8076-4625-8	Screw – Special, M5 x 16
15011-65	78-8054-8821-6	End – Cap
15011-66	78-8076-4702-5	Grommet – /28
15011-67	78-8076-4500-3	Stud – Mounting
15011-68	78-8100-1236-5	Belt Tensioning Assembly – R/H
15011-69	78-8100-1237-3	Belt Tensioning Assembly – L/H
15011-70	78-8100-1238-1	Belt Tensioning – R/H
15011-71	78-8100-1239-9	Belt Tensioning – L/H

700r3 Random Case Sealer

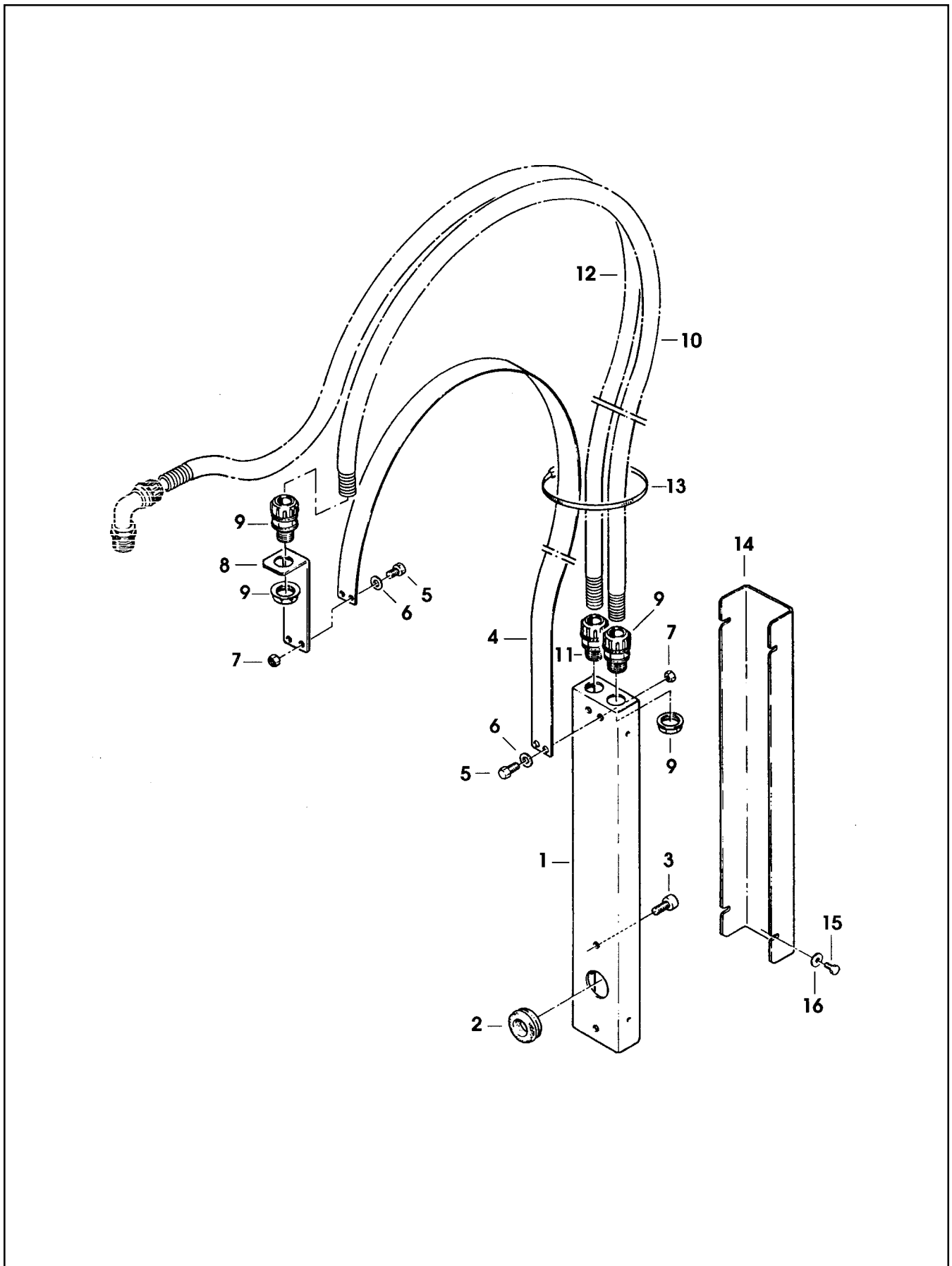

Figure 5919

Figure 5919

Ref. No.	3M Part No.	Description
5919-1	78-8091-0660-8	Housing – Wire
5919-2	78-8076-4702-5	Grommet – /28
5919-3	26-1003-7963-0	Screw – Soc Hd, M8 x 16
5919-4	78-8076-4636-5	Strap – Wire
5919-5	78-8010-7163-6	Screw – Hex Hd, M5 x 10
5919-6	78-8005-5741-1	Washer – Plain, M5
5919-7	78-8010-7417-6	Nut – Hex, M5
5919-8	78-8100-1135-9	Bracket – Strap
5919-9	78-8076-4520-1	Union – PG13, Sleeve /16
5919-10	78-8076-4521-9	Sleeving – Wire, 900 mm /16
5919-11	78-8076-4638-1	Union – PG13.5, Sleeve /14
5919-12	78-8076-4640-7	Sleeving – Wire, 1100 mm /14
5919-13	78-8060-8029-3	Clamp – 140 x 3,5
5919-14	78-8076-4641-5	Cover
5919-15	78-8010-7157-8	Screw – Hex Hd, M4 x 10
5919-16	78-8017-9018-5	Washer – Plain, M4 Special

700r3 Random Case Sealer

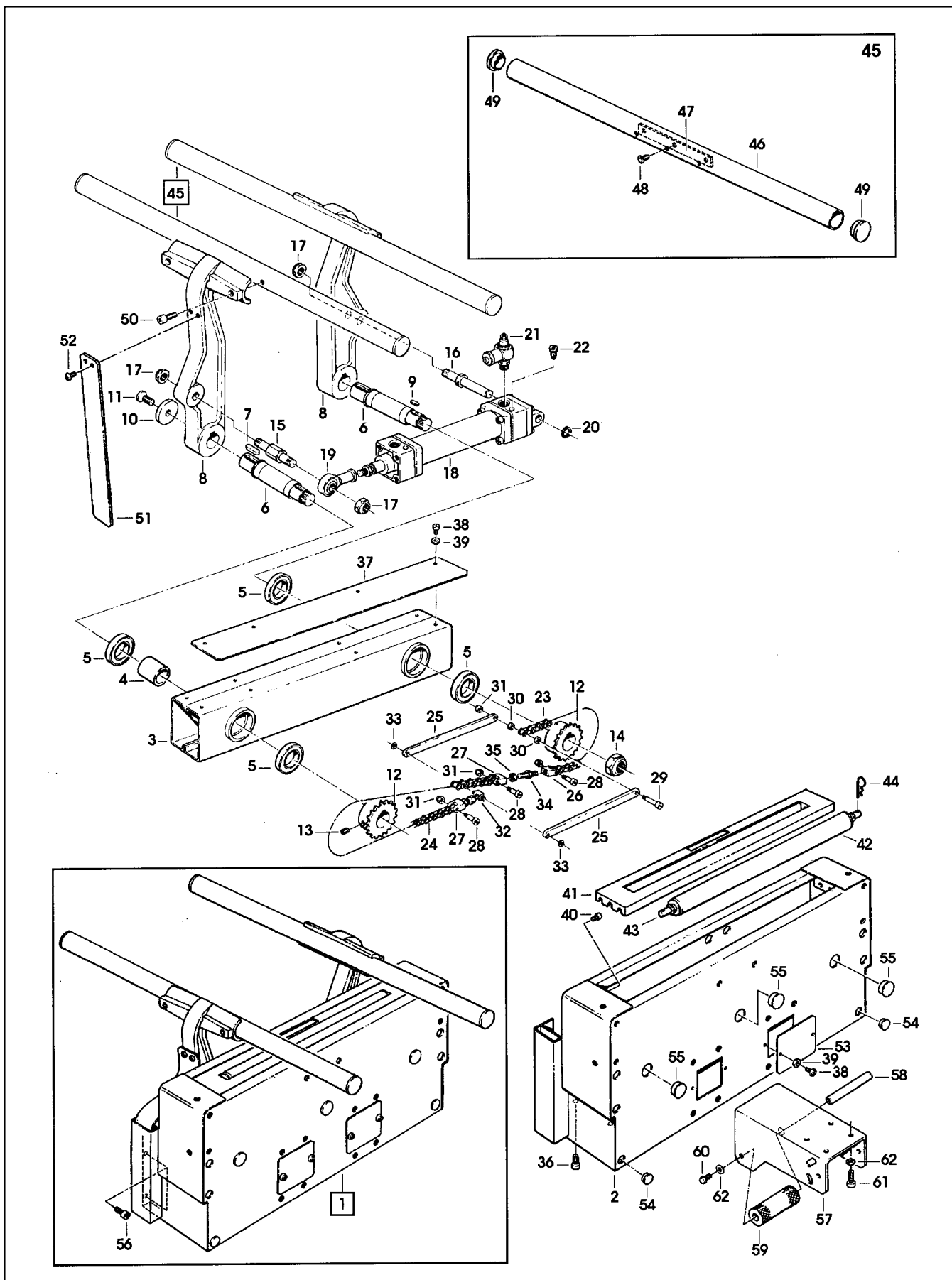

Figure 5920

Figure 5920

Ref. No.	3M Part No.	Description
5920-1	78-8100-1156-5	Infeed Conveyor Assembly
5920-2	78-8100-1157-3	Frame – Infeed
5920-3	78-8076-4566-4	Frame
5920-4	78-8076-4518-5	Spacer – Bearing
5920-5	78-8023-2551-0	Bearing – 6005-2RS
5920-6	78-8076-4567-2	Pivot – Infeed
5920-7	78-8076-4568-0	Key – 7 x 8 x 25
5920-8	78-8100-1158-1	Lever – Infeed
5920-9	78-8076-4570-6	Key – 6 x 6 x 15
5920-10	78-8054-8588-1	Washer – 8,5/40 x 6
5920-11	78-8054-8567-5	Screw – Soc Hd, Special
5920-12	78-8076-4571-4	Sprocket – Z = 20
5920-13	78-8023-2479-4	Screw – Set W/End Cup, M6 x 10
5920-14	78-8060-8416-2	Nut – Special, M20 x 1
5920-15	78-8076-4572-2	Stud – Joint
5920-16	78-8076-4573-0	Pin – Air Cylinder
5920-17	78-8091-0555-0	Nut – Special, M12
5920-18	78-8076-4575-5	Cylinder – Air, /40 x 155
5920-19	78-8057-5747-9	Mount – Cylinder Rod End
5920-20	78-8656-3965-8	External Retaining Ring – M8
5920-21	78-8091-0510-5	Regulator– Speed
5920-22	78-8076-4653-0	Screw – Cushioning Cyl./40
5920-23	78-8076-4576-3	Chain – 3/8 P=25
5920-24	78-8076-4577-1	Chain – 3/8 P=45
5920-25	78-8054-8787-9	Link – Chain
5920-26	78-8054-8788-7	Connector – Chain
5920-27	78-8054-8786-1	Connector – Chain
5920-28	78-8060-7520-2	Screw – M3 x 20
5920-29	78-8060-7519-4	Screw – M3 x 25
5920-30	78-8054-8783-8	Washer – Special
5920-31	78-8059-5517-2	Nut – Self Locking, M3
5920-32	78-8054-8784-6	Block – Chain
5920-33	78-8656-3945-0	E-Ring – M4
5920-34	78-8054-8785-3	Rod – Threaded Right/Left
5920-35	78-8010-7418-4	Nut – Hex, M6
5920-36	26-1003-7963-0	Screw – Soc Hd, M8 x 16
5920-37	78-8076-4578-9	Cover – Chain
5920-38	26-1002-5753-9	Screw – Self Tapping
5920-39	78-8005-5740-3	Washer – Plain, 4 mm
5920-40	26-1003-7943-2	Screw – Soc Hd, M4 x 12
5920-41	78-8100-1159-9	Cover
5920-42	78-8100-1160-7	Roller – /32 x 438, W/O Shaft
5920-43	78-8100-1161-5	Shaft – Roller
5920-44	78-8076-5385-8	Spring
5920-45	78-8076-4648-0	Guide Assembly
5920-46	78-8076-4649-8	Guide – Infeed
5920-47	78-8076-4650-6	Plate – Guide
5920-48	26-1002-5830-5	Screw – Soc Hd, M6 x 12
5920-49	78-8054-8779-6	End – Cap
5920-50	78-8010-7210-5	Screw – Soc Hd Hex Soc, M6 x 20
5920-51	78-8100-1162-3	Strap – Safety
5920-52	78-8094-6145-8	Screw – Phillis, M5 x 12
5920-53	78-8076-4651-4	Plate – Infeed
5920-54	78-8054-8821-6	End – Cap
5920-55	78-8060-7885-9	End – Cap, /25 x 1,2
5920-56	26-1003-7964-8	Screw – Soc Hd Hex Soc Dr, M8 x 20
5920-57	78-8076-4652-2	Support – Bracket
5920-58	78-8060-8484-0	Shaft – Roller
5920-59	78-8060-8485-7	Roller
5920-60	78-8032-0375-7	Screw – Hex Hd, M6 x 16
5920-61	26-1003-7957-2	Screw – Soc Hd Hex Hd, M6 x 16
5920-62	26-1000-0010-3	Washer – Flat, M6
5920	78-8060-8435-2	Repair Kit – Cylinder/40

700r3 Random Case Sealer

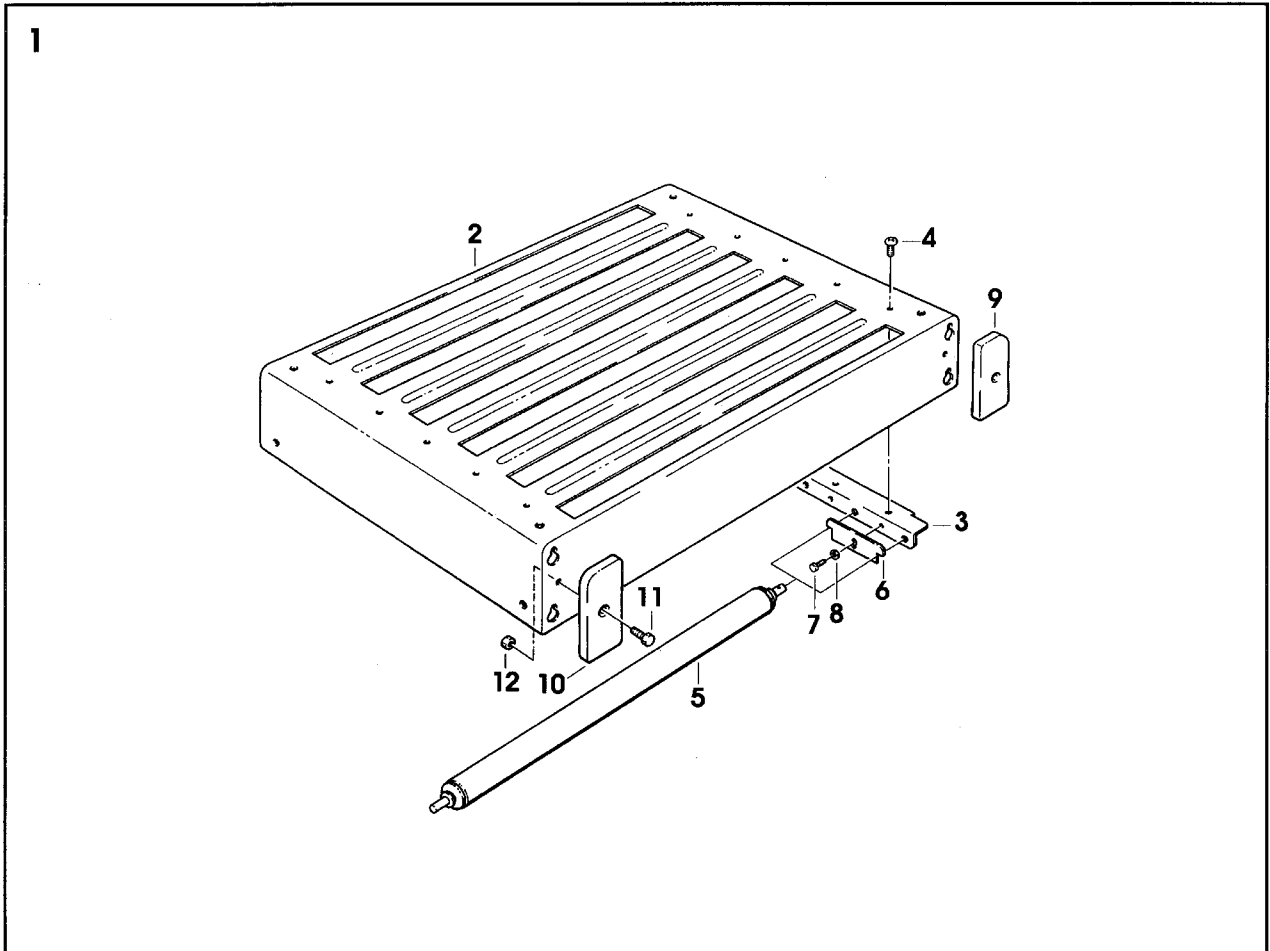
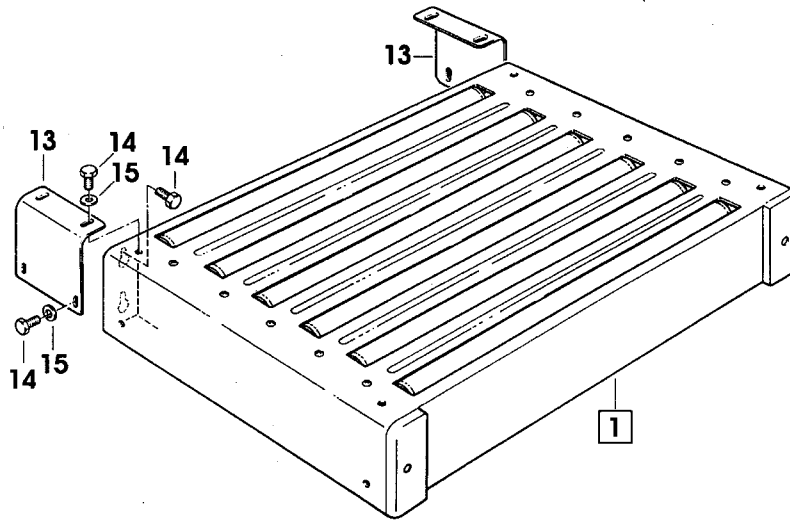

Figure 5921

Figure 5921

Ref. No.	3M Part No.	Description
5921-1	78-8100-1163-1	Conveyor Assembly – Infeed
5921-2	78-8129-6224-5	Plate – Reinforcement
5921-3	78-8100-1164-9	Plate
5921-4	78-8076-4625-8	Screw – Special, M5 x 16
5921-5	78-8076-4579-7	Roller – /32 x 492
5921-6	78-8100-1166-4	Plate – Roller
5921-7	78-8010-7157-8	Screw – Hex Hd, M4 x 10
5921-8	78-8005-5740-3	Washer – Plain, 4 mm
5921-9	78-8076-4511-0	Cap – Front, R/H
5921-10	78-8076-4512-8	Cap – Front, L/H
5921-11	78-8032-0375-7	Screw – Hex Hd, M6 x 16
5921-12	78-8010-7418-4	Nut – Hex, M6
5921-13	78-8076-4514-4	Bracket – Infeed Conveyor
5921-14	26-1003-5841-0	Screw – M8 x 16
5921-15	78-8017-9318-9	Washer – Plain, 8 mm

THIS PAGE IS BLANK



Instructions and Parts List

AccuGlide™ 2+

STD 3 Inch

Upper and Lower Taping Heads

Type 10500

Serial No. _____

For reference, record taping head(s) serial number(s) here.



3M Industrial Adhesives and Tapes

3M Center, Building 220-5E-06
St. Paul, MN 55144-1000



Important Safety Information

BEFORE INSTALLING OR
OPERATING THIS
EQUIPMENT

Read, understand, and follow
all safety and operating
instructions.

Spare Parts

It is recommended you
immediately order the spare
parts listed in the "Spare
Parts/Service Information"
section. These parts are
expected to wear through
normal use, and should be
kept on hand to minimize
production delays.

AccuGlide™ is a Trademark of
3M, St. Paul, MN 55144-1000

Litho in U.S.A

© 3M 2005 44-0009-2037-9(A)

To Our Customers:

This is the 3M-Matic™/AccuGlide™/Scotch® equipment you ordered. It has been set up and tested in the factory with Scotch® tapes. If technical assistance or replacement parts are needed, call or fax the appropriate number listed below.

Included with each machine is an Instructions and Parts List manual.

Technical Assistance:

3M-Matic™ Helpline – 1-800/328 1390. Please provide the customer support coordinator with the machine number, machine type/model and serial number. If you have a technical question that does not require an immediate response, you may Fax it to 651-736-7282.

Replacement Parts and Additional Manuals

Order parts by part number, part description and quantity required. Also, when ordering parts and/or additional manuals, include machine name, number and type. A parts order form is provided at the back of this manual.

3M/Tape Dispenser Parts

241 Venture Drive

Amery, WI 54001-1325

1-800/344 9883

FAX# 715/268 8153

Minimum billing on parts orders will be \$25.00. Replacement part prices available on request.

\$10.00 restocking charge per invoice on returned parts.

Note : Outside the U.S., contact the local 3M subsidiary for parts ordering information.



3M Industrial Adhesives and Tapes

3M Center, Building 220-5E-06
St. Paul, MN 55144-1000

"3M-Matic", "AccuGlide" and "Scotch" are trademarks of
3M, St. Paul, Minnesota 55144-1000

Printed in U.S.A.

© 3M 2005 44-0009-1851-4(F)

To Our Customers:

This is the 3M-Matic™/AccuGlide™/Scotch® equipment you ordered. It has been set up and tested in the factory with Scotch® tapes. If any problems occur when operating this equipment and you desire a service call or phone consultation, call, write or fax the appropriate number listed below.

Included with each machine is an Instructions and Parts List manual.

**SERVICE, REPLACEMENT PARTS AND ADDITIONAL MANUALS
AVAILABLE DIRECT FROM:**

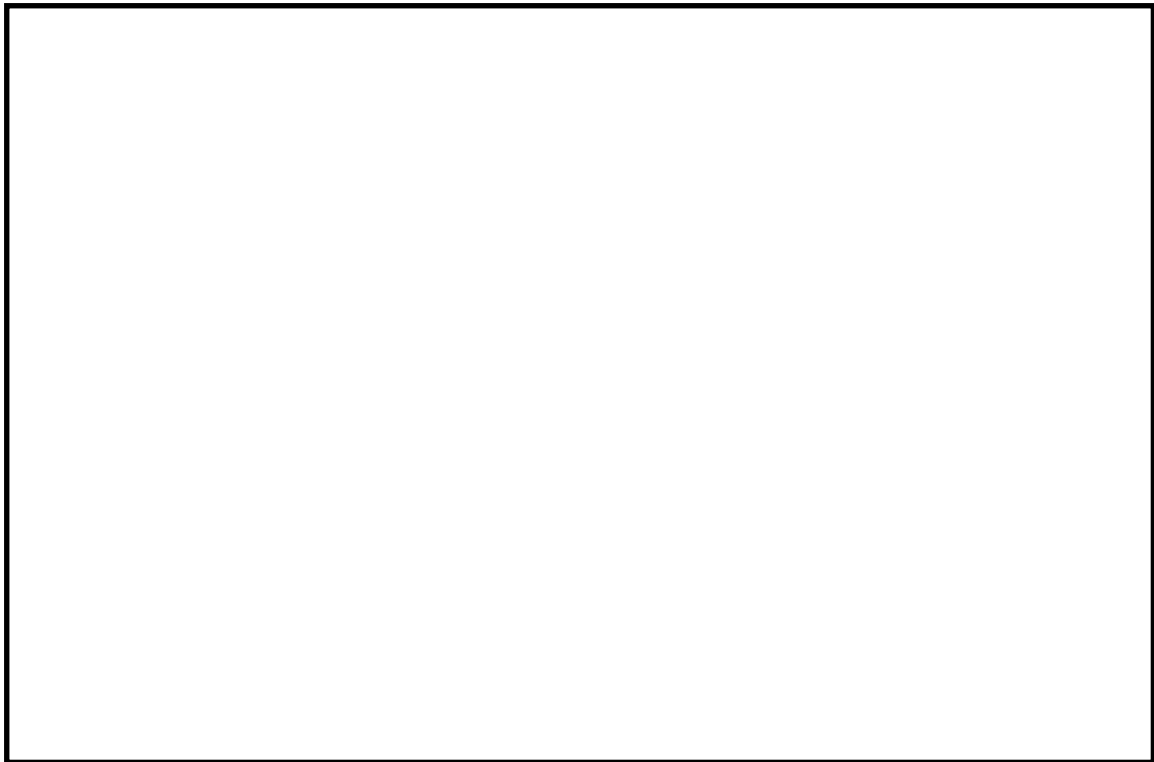

Order parts by part number, part description and quantity required. Also, when ordering parts and/or additional manuals, include machine name, number and type.



3M Industrial Adhesives and Tapes
3M Center, Building 220-5E-06
St. Paul, MN 55144-1000

"3M-Matic", "AccuGlide" and "Scotch" are trademarks of
3M, St. Paul, Minnesota 55144-1000

Printed in U.S.A.

© 3M 2005 44-0009-1852(E)

Instruction Manual

AccuGlide™ 2+ STD 3 Inch
Upper and Lower Taping Heads
Type 10500

Table of Contents	Page
Equipment Warranty and Limited Remedy	ii
Taping Head Contents	ii
Intended Use	1
Important Safeguards	2-3
Specifications	4 - 5
Dimensional Drawing	5
Installation	6
Receiving and Handling	6
Installation Guidelines	6
Tape Leg Length	6
Tape Width Adjustment	6
Operation	7 - 9
Tape Loading – Upper Taping Head	8
Tape Loading – Lower Taping Head	8 - 9
Maintenance	10 - 11
Blade Replacement	10
Blade Guard	10
Blade Oiler Pad	10
Cleaning	11
Applying/Buffering Roller Replacement	11
Adjustments	12 - 14
Tape Latch Alignment	12
Tape Drum Friction Brake	12
Applying Mechanism Spring	13
One-Way Tension Roller	13
Tape Leg Length	14
Leading Tape Leg Length Adjustment	14
Changing Tape Leg Length From 70 to 50 mm [2-3/4 to 2 Inch]	14
Troubleshooting	15 - 16
Troubleshooting Guide	15 - 16
Spare Parts/Service Information	17
Recommended Spare Parts	17
Replacement Parts and Service	17
Replacement Parts Illustrations and Parts List	Yellow Section 18 - 35

Equipment Warranty and Limited Remedy: THE FOLLOWING WARRANTY IS MADE IN LIEU OF ALL OTHER WARRANTIES, EXPRESS OR IMPLIED, INCLUDING, BUT NOT LIMITED TO, ANY IMPLIED WARRANTY OF MERCHANTABILITY OR FITNESS FOR A PARTICULAR PURPOSE AND ANY IMPLIED WARRANTY ARISING OUT OF A COURSE OF DEALING, CUSTOM OR USAGE OF TRADE:

3M sells its **AccuGlide™ 2+ STD 3 Inch Upper and Lower Taping Heads, Type 10500** with the following warranty:

1. The Taping Head blade, springs and rollers will be free from defects in material and manufacture for ninety (90) days after delivery.
2. All other Taping Head parts will be free from defects in material and manufacture for three (3) years after delivery.

If any part is defective within this warranty period, your exclusive remedy and 3M's and seller's sole obligation shall be, at 3M's option, to repair or replace the part. 3M must receive actual notice of any alleged defect within a reasonable time after it is discovered, but in no event shall 3M have any obligation under this warranty unless it receives such notice within five (5) business days after the expiration of the warranty period. All notices required hereunder shall be given to 3M solely through the 3M-Matic™ Helpline (800-328-1390). To be entitled to repair or replacement as provided under this warranty, the part must be returned as directed by 3M to its factory or other authorized service station designated by 3M. If 3M is unable to repair or replace the part within a reasonable time after receipt thereof, 3M, at its option, will replace the equipment or refund the purchase price. 3M shall have no obligation to provide or pay for the labor required to remove any part or equipment or to install the repaired or replacement part or equipment. 3M shall have no obligation to repair or replace those parts failing due to normal wear, inadequate or improper maintenance, inadequate cleaning, non-lubrication, improper operating environment, improper utilities, operator error or misuse, alteration or modification, mishandling, lack of reasonable care, or due to any accidental cause.

Limitation of Liability: Except where prohibited by law, 3M and seller will not be liable for any loss or damage arising from this 3M equipment, whether direct, indirect, special, incidental, or consequential, regardless of the legal theory asserted, including breach of warranty, breach of contract, negligence, or strict liability.

Note: The foregoing Equipment Warranty and Limited Remedy and Limitation of Liability may be changed only by a written agreement signed by authorized representatives of 3M and seller.

Taping Head Contents

AccuGlide™ 2+ STD 3 Inch Upper and Lower Taping Heads consist of:

Qty.	Part Name
1	Taping Head Assembly
1	Tape Drum and Bracket Assembly
1	Hardware and Spare Parts Kit
1	Threading Tool

Intended Use

The intended use of the **AccuGlide™ 2+ STD 3 Inch Upper and Lower Taping Heads** is to apply a "C" clip of **Scotch®** pressure-sensitive film box sealing tape to the top and/or bottom center seam of regular slotted containers.

These taping heads are incorporated into most standard **3M-Matic™** case sealers. The compact

size and simplicity of the taping head also makes it suitable for mounting in box conveying systems other than **3M-Matic™** case sealers. This includes replacement of other types of taping, gluing or stapling heads in existing case sealing machines. The **AccuGlide™ 2+ STD Taping Heads** have been designed and tested for use with **Scotch®** pressure-sensitive film box sealing tape.

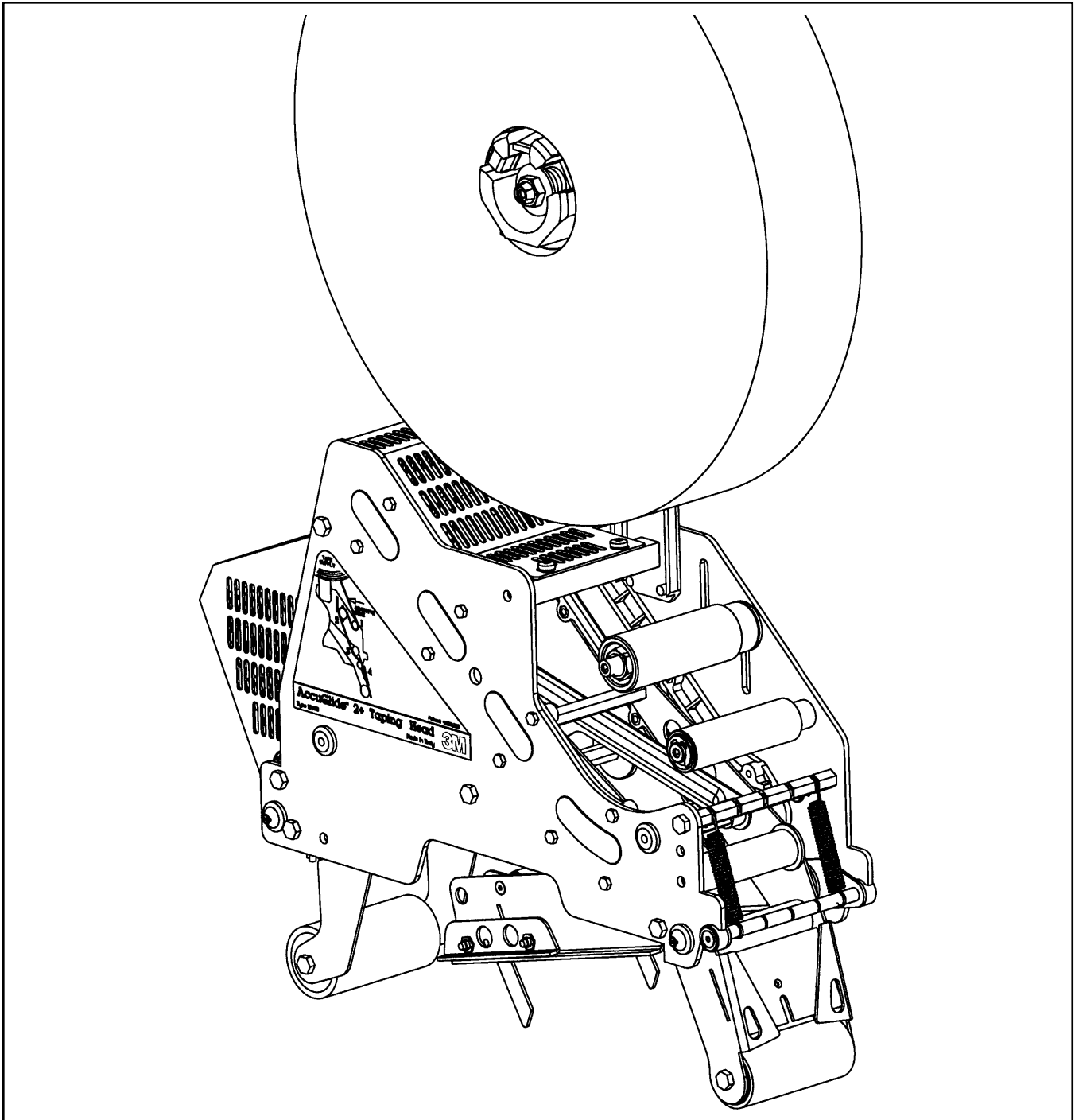

AccuGlide™ 2+ STD 3 Inch Upper Taping Head, Type 10500

Important Safeguards



This safety alert symbol identifies important safety messages in this manual. **READ AND UNDERSTAND THEM BEFORE INSTALLING OR OPERATING THIS EQUIPMENT.**

Explanation of Signal Word Consequences



WARNING: Indicates a potentially hazardous situation, which, if not avoided, could result in death or serious injury and/or property damage.



CAUTION: Indicates a potentially hazardous situation, which, if not avoided, may result in minor or moderate injury and/or property damage.



WARNING

- **To reduce the risk associated with mechanical hazards:**
 - Read, understand and follow all safety and operating instructions before operating or servicing the case sealer
 - Allow only properly trained and qualified personnel to operate and/or service this equipment
- **To reduce the risk associated with shear, pinch, and entanglement hazards:**
 - Turn air and electrical supplies off on associated equipment before performing any adjustments, maintenance, or servicing the taping heads
 - Never attempt to work on the taping head or load tape while the box drive system is running
- **To reduce the risk associated with sharp blade hazards:**
 - Keep hands and fingers away from tape cutoff blades under orange blade guards. The blades are extremely sharp



CAUTION

- **To reduce the risk associated with muscle strain:**
 - Use proper body mechanics when removing or installing taping heads that are moderately heavy or may be considered awkward to lift
- **To reduce the risk associated with impact hazards:**
 - Place the taping head on a smooth level surface when maintaining or servicing this equipment

Important Safeguards (Continued)

Important – In the event the following safety labels are damaged or destroyed, **they must be replaced to ensure operator safety**. See "Replacement Parts Illustrations and Parts Lists" for label part numbers.

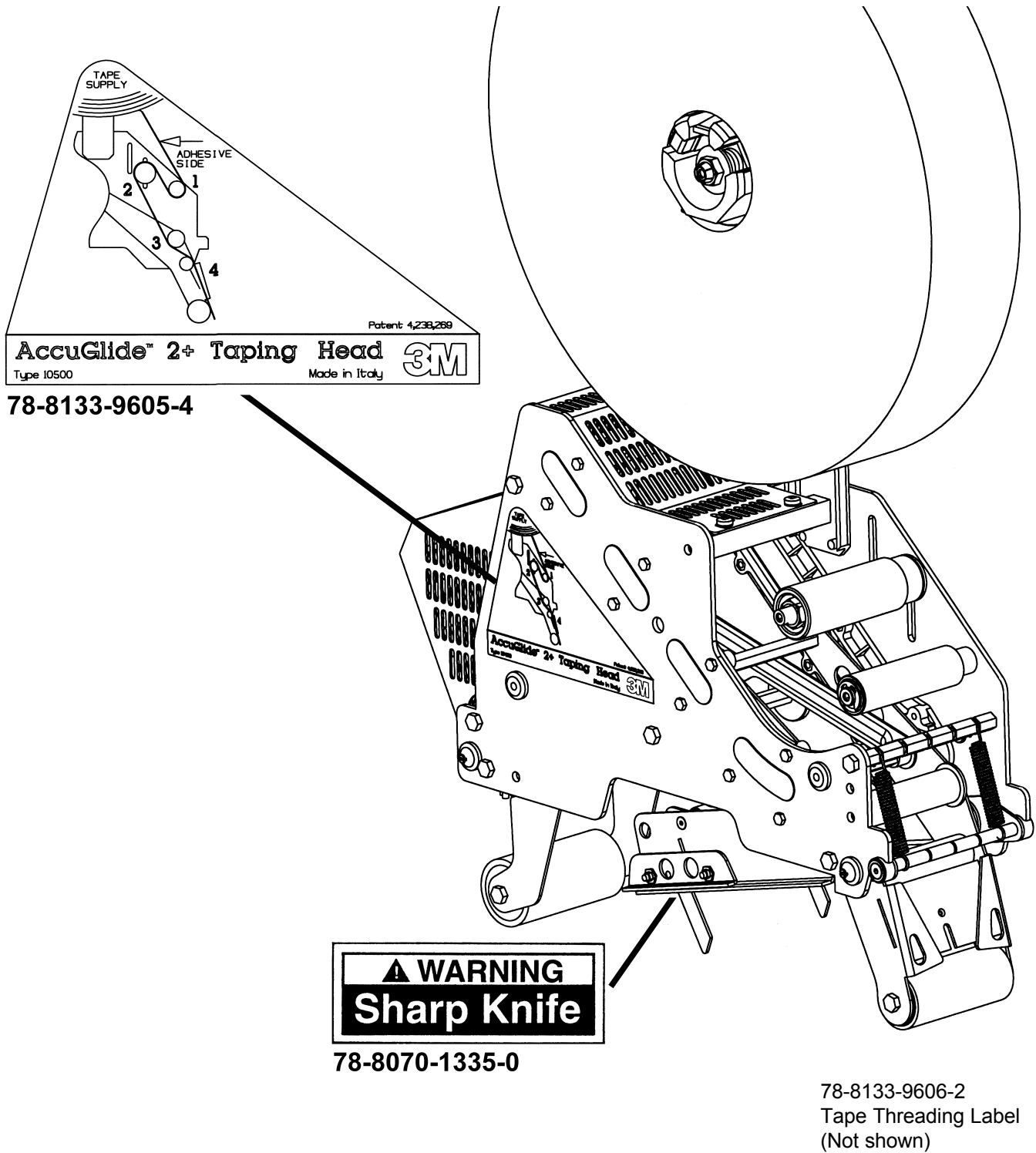

Figure 1-1 – Replacement Labels/3M Part Numbers

Specifications

1. **Tape:**

For use with **Scotch**[®] pressure-sensitive film box sealing tapes.

2. **Tape Width:**

48 mm [2 inches] minimum to 72 mm [3 inches] maximum.

3. **Tape Roll Diameter:**

Up to 405 mm [16 inches] maximum on a 76.2 mm [3 inch] diameter core.
(Accommodates all system roll lengths of **Scotch**[®] film tapes.)

4. **Tape Application Leg Length - Standard:**

70 mm ± 6 mm [2-3/4 inches ± 1/4 inch]

Tape Application Leg Length - Optional:

50 mm ± 6 mm [2 inches ± 1/4 inch] (See "Adjustments – Tape Leg Length.")

5. **Box Size Capacities:**

For use with center seam regular slotted containers.

	Minimum		Maximum
Length	– 150 mm [6 inches]		Unlimited
Height	– 120 mm [4-3/4 inches] (most "3M-Matic" Case Sealers)		Limited by Case Sealer
	– 90 mm [3-1/2 inches] (with optional 2 inch leg length)		
Width	– 150 mm [6 inches]		

When upper and lower taping heads are used on "**3M-Matic**" case sealers, refer to the respective instruction manual specifications for box weight and size capacities.

6. **Operating Rate:**

Conveyor speeds up to 0.40 m/s [80 FPM] maximum.

7. **Operating Conditions:**

Use in dry, relatively clean environments at 5° to 40° C [40° to 105° F] with clean dry boxes.

Important – Taping heads should not be washed down or subjected to conditions causing moisture condensation on components.

8. **Taping Head Dimensions:**

Length	–	457 mm [18 inches]
Height	–	560 mm [22 inches] (with tape drum)
Width	–	130 mm [5-1/8 inches] (without mounting spacers)
Weight	–	Packaged: 8.2 kg [18 lbs.] Unpackaged: 7.3 kg [16 lbs.]

Specifications (Continued)

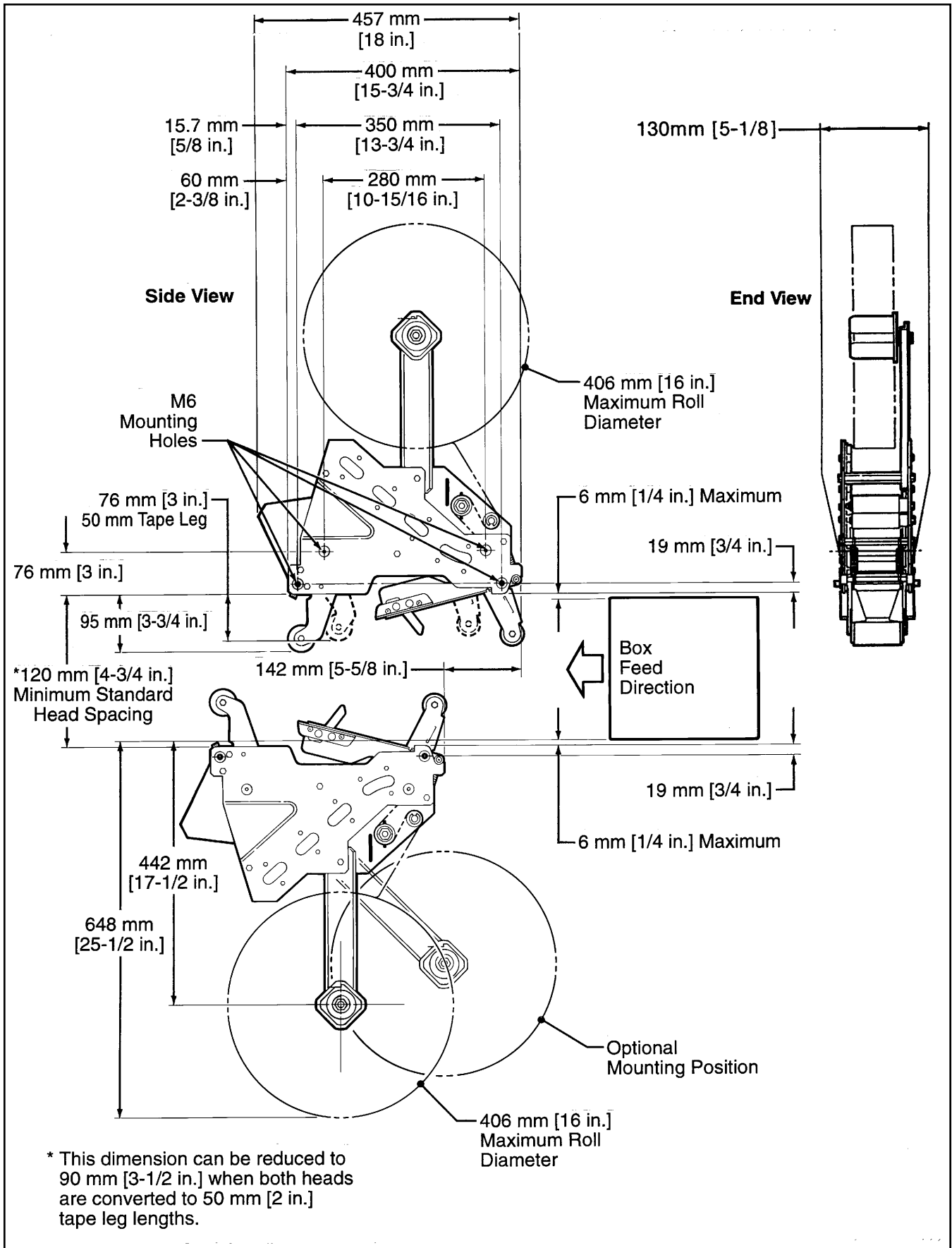

Figure 2-1 – Dimensional Drawing

Installation

WARNING

- **To reduce the risk associated with sharp blade hazards:**
 - Keep hands and fingers away from tape cutoff blades under orange blade guards. The blades are extremely sharp

Receiving And Handling

After the taping head assembly has been unpackaged, examine the unit for damage that might have occurred during transit. **If damage is evident, file a damage claim immediately** with the transportation company and also notify your 3M Representative.

Installation Guidelines

The taping head assembly can be used in converting existing or in custom made machinery. It can be mounted for top taping or bottom taping. Refer to "Box Size Capacities," as well as Figure 2-1 in the Specifications section, for the following points in making such installations:

CAUTION

- **To reduce the risk associated with muscle strain:**
 - Use proper body mechanics when removing or installing taping heads that are moderately heavy or may be considered awkward to lift

Important – Always conduct a hazard review to determine appropriate guarding requirements when the installation is in an application other than 3M-Matic(TM) equipment

1. The box conveying system must positively propel the box in a continuous motion, **not exceeding 0.40 m/s [80 feet per minute]**, past the taping head assembly since the box motion actuates the taping mechanism.
2. If a pusher or cleated conveyor is being used, steps should be taken in the conveyor design to **prevent the pusher from contacting the applying or buffing roller arms resulting in damage to the taping head.**

3. Figure 2-1 illustrates the typical mounting relationship for opposing taping head assemblies to allow taping of box heights down to 90 mm [3-1/2 inches]. **To tape box heights down to 70 mm [2-3/4 inches], the taping heads must be completely staggered so only one tape seal is being applied at one time.**

Note – AccuGlide™ 2+ STD Upper Taping Head is supplied with a buffing arm guard. Adjustments to this guard may be required to install the taping head into some older design 3M-Matic™ case sealers.

4. Mounting studs are provided with the taping head, but special installations may require alternate means for mounting.
5. Box hold-down or guide skis should be provided and the taping head mounted so that the side plates are 6 mm [1/4 inch] maximum away from the ski surface on which the box rides.

Tape Leg Length

Taping heads are factory set to apply standard 70 mm [2-3/4 inch] tape legs. The heads can be converted to apply 50 mm [2 inch] tape legs if desired but both upper and lower heads must be set to apply the same tape leg length. See "Adjustments – Changing Tape Leg Length From 70 to 50 mm [2-3/4 to 2 Inches]."

Also, the conveyor speed at which the product moves through the taping heads, affects the leading and trailing tape leg length. See "Adjustments section – Leading Tape Leg Length Adjustment."

Tape Width Adjustment

Taping heads are factory set to apply 72 mm [3 inch] wide tape. If it is necessary to align the tape or to apply narrower tapes, refer to "Adjustments – Tape Web Alignment" for set-up procedure.

Operation

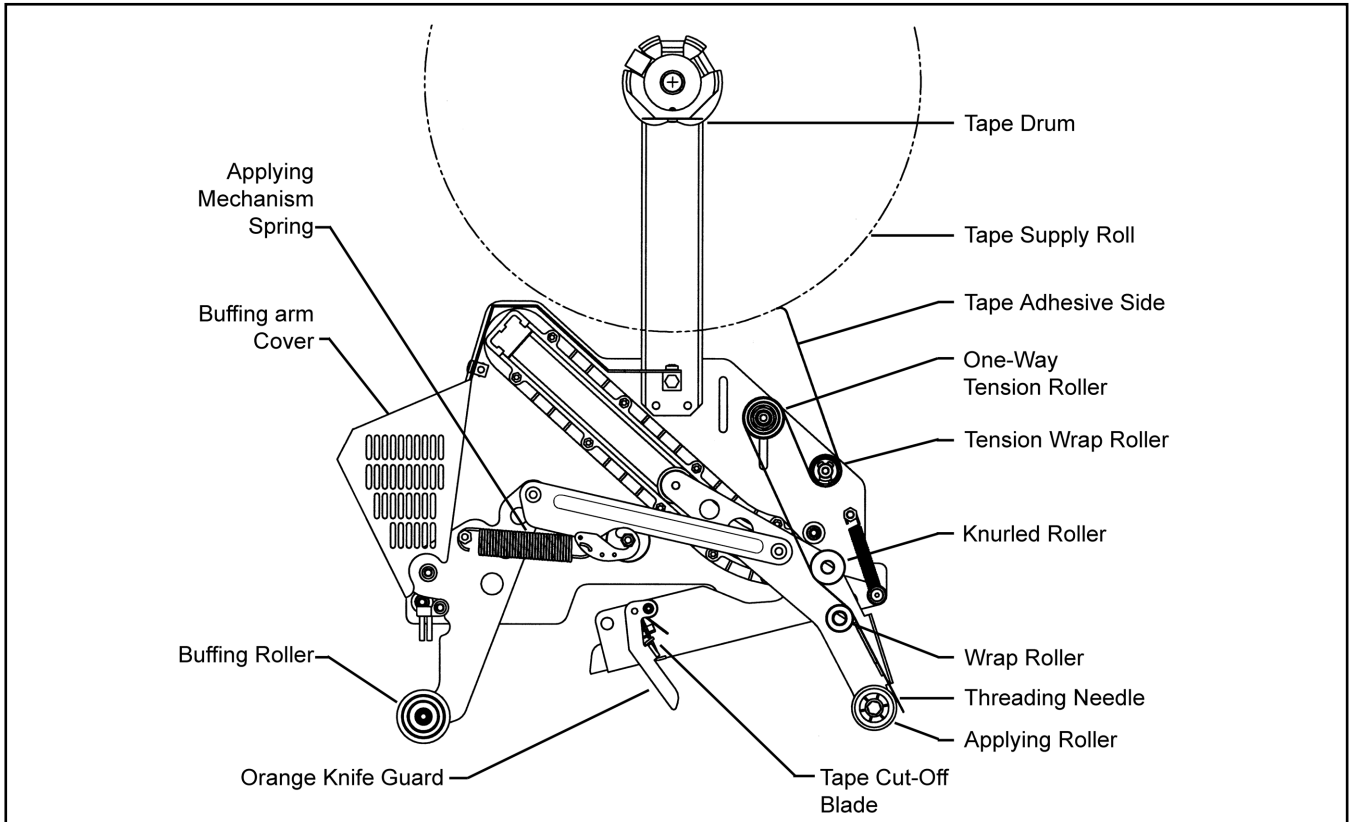

Figure 3-1 – Taping Head Components/Threading Diagram, Upper Head (Left Side View)

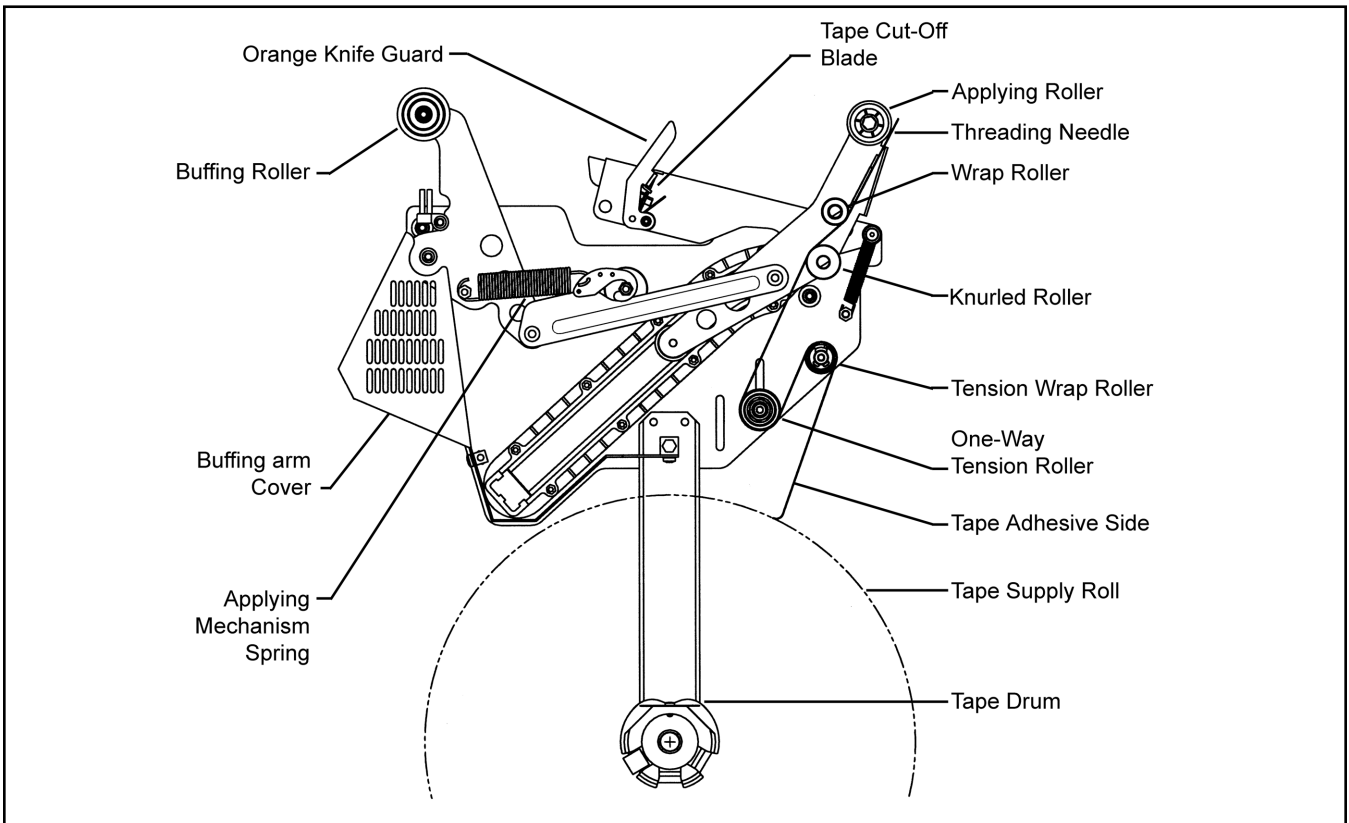

Figure 3-2 – Taping Head Components/Threading Diagram – Lower Head (Left Side View)

Operation (Continued)

WARNING

- **To reduce the risk associated with shear, pinch, and entanglement hazards:**
 - Turn air and electrical supplies off on associated equipment before performing any adjustments, maintenance, or servicing the machine or taping heads
 - Never attempt to work on the taping heads or load tape when the box drive system is running
- **To reduce the risk associated with sharp blade hazards:**
 - Keep hands and fingers away from tape cutoff blades under orange blade guards. The blades are extremely sharp

It is recommended that the detailed instructions and sketches in this manual be referred to the first few times the taping head is loaded/threaded until the operator becomes thoroughly familiar with the tape loading operation.

Note – Remove tape roll before removing taping head from machine to minimize weight.

CAUTION

- **To reduce the risk associated with muscle strain:**
 - Use proper body mechanics when removing or installing taping heads that are moderately heavy or may be considered awkward to lift
- **To reduce the risk associated with impact hazards:**
 - Place the taping head on a smooth level surface when maintaining or servicing this equipment

Tape Loading – Upper Taping Head

1. Place the upper taping head in a convenient working position.
2. Refer to Figures 3-3 to 3-5 and tape threading label. Position the tape supply roll so the adhesive side of tape is facing the front of the taping head as it is pulled from the supply roll.
3. Attach the threading needle to the end of the roll. Guide the threading needle around the wrap roller (Position 1) then back around the one-way tension roller (Position 2).
4. Continue pulling the threading needle down and guide it between the two rollers on the apply arm (Position 3).

5. Pull the threading needle down until the tape travels between the apply plate and the ears of the apply arm (Position 4) until it extends past the applying roller. When properly threaded the adhesive side of the tape should be facing the knurled rollers at position 2 and also position 3.
6. Cut away any excess tape.

Important – Do not cut against the apply roller - roller damage could occur.

Tape Loading – Lower Taping Head

1. Remove the lower taping head from the conveyor bed or associated equipment and place it a convenient working position.
2. The lower taping head is loaded and threaded in the same manner as the upper head. Follow the upper taping head tape loading/threading procedure.

Figure 3-3

Insert threading needle through rollers in direction indicated by arrows.

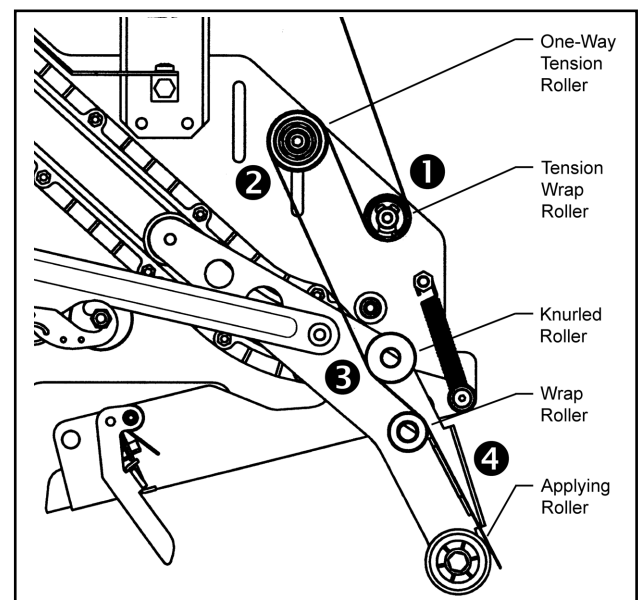

Figure 3-3 – Tape Loading/Threading

Operation (Continued)

Figure 3-4

Place tape roll on tape drum to dispense tape with adhesive side forward. Seat tape roll fully against back flange of drum. Adhere tape lead end to threading needle as shown.

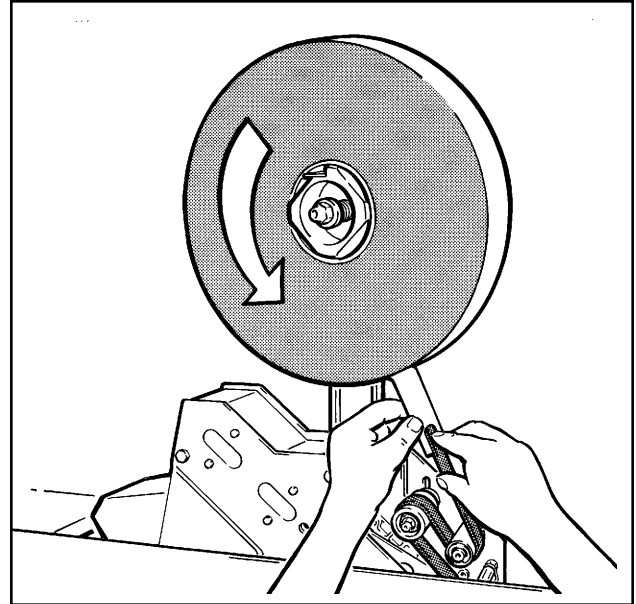

Figure 3-4 – Tape Loading/Threading

Figure 3-5

WARNING

- **To reduce the risk associated with sharp blade hazards:**
 - Keep hands and fingers away from tape cutoff blades under orange blade guards. The blades are extremely sharp

Manually turn tape roll to create slack tape while pulling threading needle through tape applying mechanism until needle is through and tape is in alignment with applying roller.

Excess tape can be cut with a scissors at applying roller.

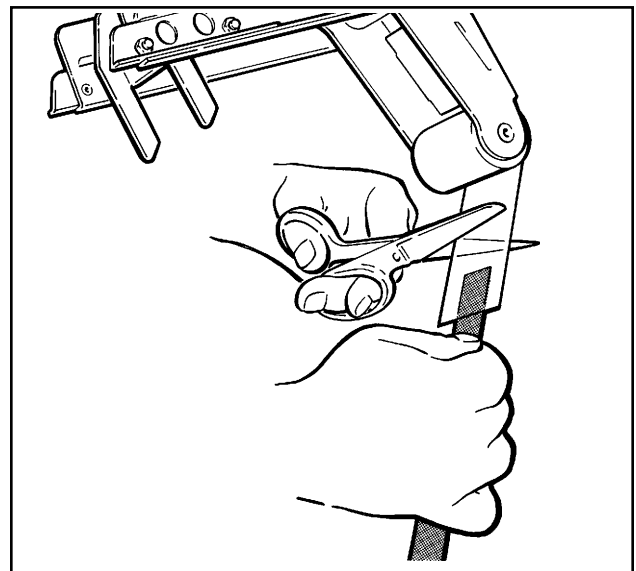

Figure 3-5 – Tape Loading/Threading

Maintenance

WARNING

- **To reduce the risk associated with shear, pinch, and entanglement hazards:**
 - Turn air and electrical supplies off on associated equipment before performing any adjustments, maintenance, or servicing the taping heads
 - Never attempt to work on the taping head or load tape while the box drive system is running
- **To reduce the risk associated with sharp blade hazards:**
 - Keep hands and fingers away from tape cutoff blades under orange blade guards. The blades are extremely sharp

The **AccuGlide™ STD 2+ 3 Inch Taping Head** has been designed for long, trouble free service. The taping head will perform best when it receives routine maintenance and cleaning. Taping head components that fail or wear excessively should be promptly repaired or replaced to prevent damage to other portions of the head or to the product.

Blade Replacement, Upper and Lower Taping Heads – Figure 4-1

WARNING

- **To reduce the risk associated with sharp blade hazards:**
 - Keep hands and fingers away from tape cutoff blade edge. The knives are extremely sharp

1. Loosen, but do not remove, the blade screws (**A**). Remove and discard old blade.
2. Mount the new blade (**B**) with the **beveled side away** from the blade holder.

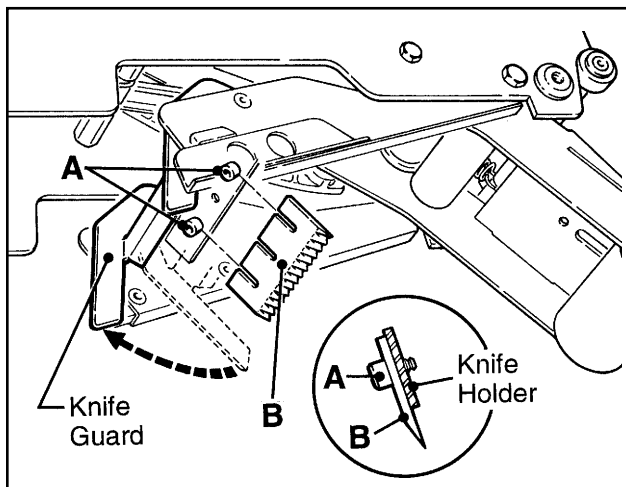

Figure 4-1 – Blade Replacement

3. Bottom the blade slots against the screws. (This will position the blade at the correct angle.) Tighten the blade screws to secure the blade.

***Note** – Check the blade position to insure proper clearance between blade and guard by slowly pivoting the blade guard back.*

Blade Guard

The blade guard covers the blade whenever a box is not being taped. Periodically check to be sure the blade guard is functioning properly and returning to cover the blade. Replace any defective parts.

Blade Oiler Pad

WARNING

- **To reduce the risk associated with sharp blade hazards:**
 - Keep hands and fingers away from tape cutoff blade edge. The knives are extremely sharp

The taping heads are equipped with a felt oiler pad that has been pre-lubricated at the factory to provide a film of oil on the cutting edge of the blade to reduce adhesive build-up. Apply SAE #30 non-detergent oil as needed. **Saturate felt oiler pad.**

Should tape adhesive build-up occur on blade, carefully wipe clean with an oily cloth.

WARNING

- **To reduce the risk associated with shear, pinch, and entanglement hazards:**
 - Turn air and electrical supplies off on associated equipment before performing any adjustments, maintenance, or servicing the taping heads
 - Never attempt to work on the taping head or load tape while the box drive system is running
- **To reduce the risk associated with sharp blade hazards:**
 - Keep hands and fingers away from tape cutoff blades under orange blade guards. The blades are extremely sharp

Cleaning

Regular slotted containers produce a great deal of dust and paper chips when conveyed through taping heads. If this dust is allowed to build-up on the heads, it can cause wear on the moving parts. Excessive dirt build-up should be wiped off with a damp cloth. Cleaning should be done **once per month**, depending on the number and type of boxes used. If the boxes used are dirty, or if the environment in which the heads operate is dusty, cleaning on a more frequent basis may be necessary.

Note – Never attempt to remove dirt from taping heads by blowing it out with compressed air. This can cause the dirt to be blown inside the components onto sliding surfaces. Dirt in these areas can cause serious equipment damage. Never wash down or subject taping heads to conditions causing moisture condensation on components. Serious equipment damage could result.

Applying/Buffering Roller Replacement

Replacing roller requires removal of shaft and mounting screws. With no area on the shaft to grip, the shaft often turns when attempting to remove the second screw.

To ease removal of second screw, a 4 mm hex socket has been provided at the bottom of the threads in both ends of the shaft. Insert a 4 mm hex key wrench into this socket after removing one screw to hold the shaft for removal of the second screw. See Figure 4-2.

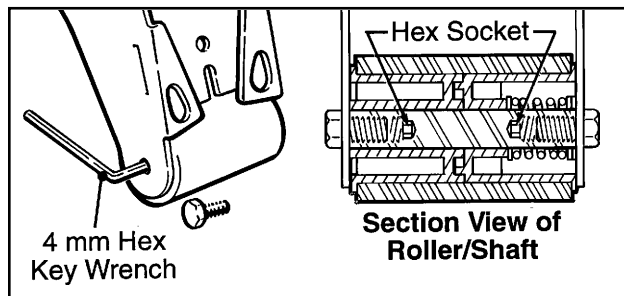

Figure 4-2 – Section View of Roller Shaft

Adjustments

WARNING

- **To reduce the risk associated with shear, pinch, and entanglement hazards:**
 - Turn air and electrical supplies off on associated equipment before performing any adjustments, maintenance, or servicing the machine or taping heads
 - Never attempt to work on the taping head or load tape while the box drive system is running

Tape Latch Alignment – Figure 5-1

The Latching tape drum assembly is pre-set to accommodate 72 mm [3 inch] wide tape. The tape drum assembly is adjustable to provide alignment of narrower tapes.

To move the latch to a position that corresponds to a new tape core width (Figure 5-1):

1. Remove screw from the latch.
2. Move the latch to the position that corresponds to the tape core width.
3. Replace screw in the new latch location.

To adjust or center the tape width on the centerline of the taping head, and therefore box center seam, (Figure 5-2):

1. Loosen the locking hex nut behind tape drum bracket on tape drum shaft. Use an adjustable wrench or 25 mm open end wrench.

Note – To set up 72 mm tape drum for 48 mm tape, disassemble tape drum from bracket and install lock nut between tape drum and bracket as shown in inset, Figure 5-3.

2. Turn tape drum shaft in or out to center the tape web (use 5 mm hex wrench).
3. Tighten locking hex nut to secure the adjustment.

No other components require adjustment for tape web alignment.

Tape Drum Friction Brake – Figure 5-3

The tape drum friction brake on each taping head is **pre-set** for normal operation to prevent tape roll over travel. Should tension adjustment be required, **turn the self-locking nut on the shaft to vary compression of the spring**. Turn the nut **clockwise to increase** the braking force, and **counterclockwise to decrease** the braking force. Adjust brake to minimum tension to prevent excessive tape roll over travel.

Note – Excess braking force will cause poor tape application and may lead to tape tabbing on the trailing tape leg.

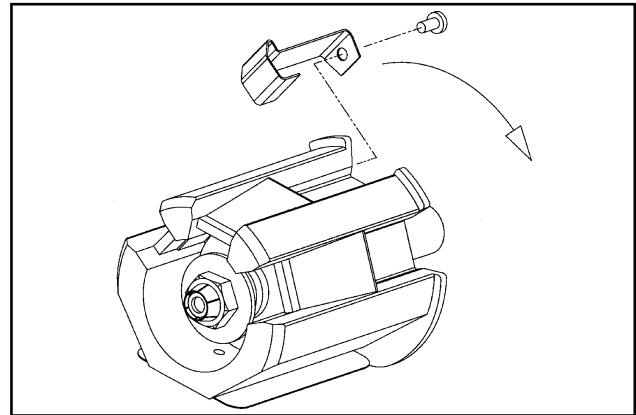

Figure 5-1 – Tape Latch Alignment

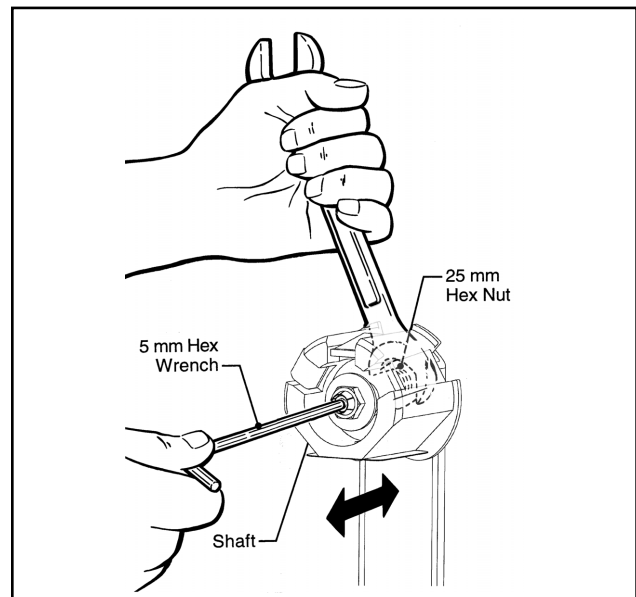

Figure 5-2 – Tape Web Alignment

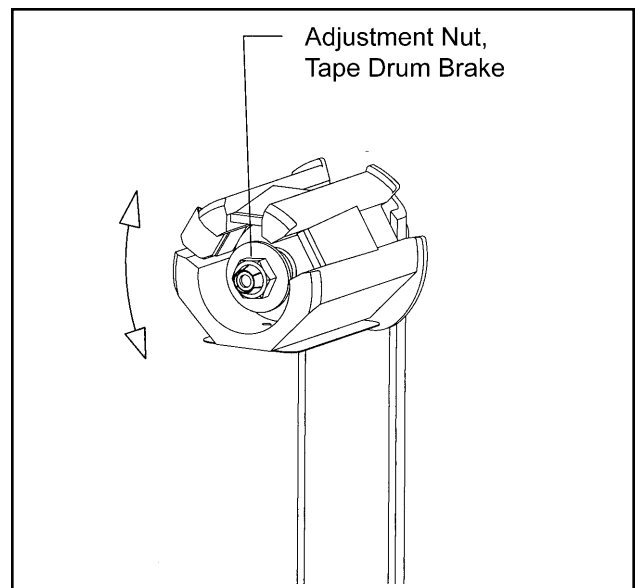

Figure 5-3 – Tape Drum Friction Brake

Adjustments (Continued)

WARNING

- **To reduce the risk associated with shear, pinch, and entanglement hazards:**
 - Turn air and electrical supplies off on associated equipment before performing any adjustments, maintenance, or servicing the machine or taping heads
 - Never attempt to work on the taping head or load tape while the box drive system is running

Applying Mechanism Spring

To obtain access to the spring, remove the taping head cover (four mounting screws). Replace cover when finished.

The applying mechanism spring, shown in Figures 5-4A and 5-4B, controls applying and buffing roller pressure on the box and returns the mechanism to the reset position. The spring pressure is pre-set, as shown in Figure 5-4A for normal operation, but is adjustable.

If a tape gap appears on the trailing surface of the box increase spring pressure. If the front of the box is being crushed by the applying roller decrease spring pressure.

Removing the spring end loop from the spring holder and placing loop in other holes provided, as shown in Figure 5-4B, will adjust the spring pressure.

One-Way Tension Roller

Figure 5-5

The one-way tension roller is factory set. When replacing this assembly, the roller must have 0,5 kg [1 lb.] minimum tangential force when turning.

To Adjust Tension:

1. Wrap a cord or small strap (non-adhesive) 4-6 turns around the tension roller.
2. Attach a spring scale to the end of the cord or strap.
3. Turn the adjusting nut with the socket wrench provided, until a force of approximately 0.5 kg to 0.9 kg [1 to 2 lbs.] is required to turn the roller by pulling on the spring scale.

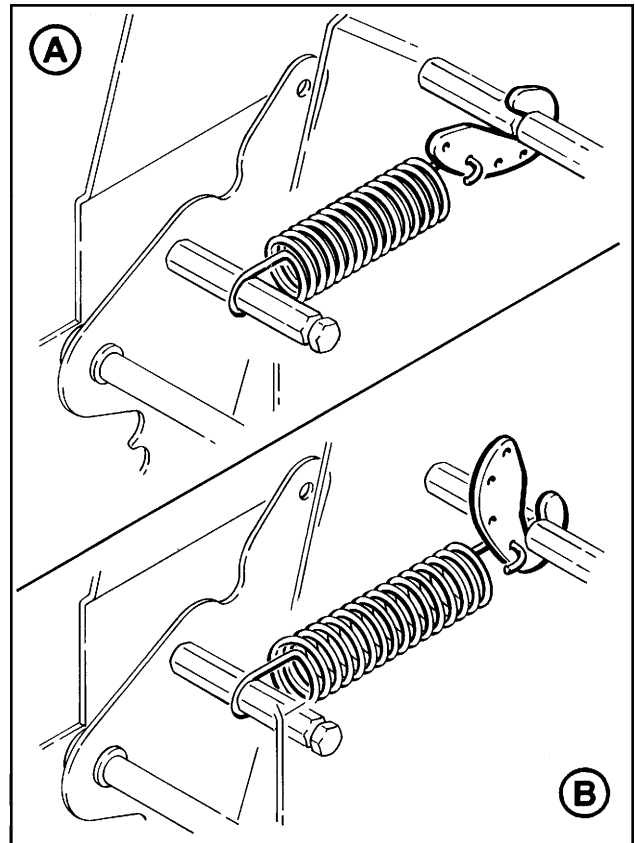

Figure 5-4 – Applying Mechanism Spring

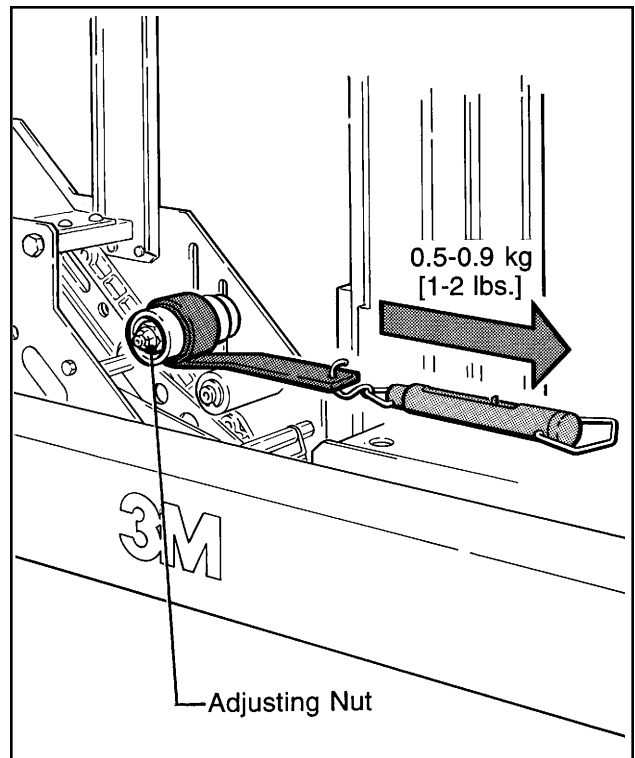

Figure 5-5 – One-Way Tension Roller

Adjustments (Continued)

WARNING

- **To reduce the risk associated with shear, pinch, and entanglement hazards:**
 - Turn air and electrical supplies off on associated equipment before performing any adjustments, maintenance, or servicing the machine or taping heads
 - Never attempt to work on the taping head or load tape while the box drive system is running

Tape Leg Length

WARNING

- **To reduce the risk associated with sharp blade hazards:**
 - Keep hands and fingers away from tape cutoff knives under orange blade guards. The blades are extremely sharp

LEADING TAPE LEG LENGTH ADJUSTMENT – Figure 5-6

The one-way tension roller position is adjustable to control the leading tape leg length.

Moving this roller farther away from the box top or bottom surface will decrease the leading leg length. Moving it closer to the box top or bottom surface will increase the leading leg length.

CHANGING TAPE LEG LENGTH FROM 70 to 50 mm [2-3/4 TO 2 INCHES] – Figure 5-7

Note – When changing tape leg length, both upper and lower heads must be adjusted to apply the same leg lengths.

1. Remove and retain two hex head screws and remove the brush from normal position “A” on side frame.
2. Remount and secure brush in position “A-A” on side frame forward of normal location using original fasteners.
3. Remove cut-off bracket extensions from position “B”.
4. Remount cut-off bracket extensions in forward position “B-B”.
5. Remove and retain the one-way tension roller assembly from slot “C” in frame.
6. Remount tension roller assembly near top of slot “C-C” in frame using original fasteners.
7. Adjust tension roller according to “Leading Tape Leg Length Adjustment” above.

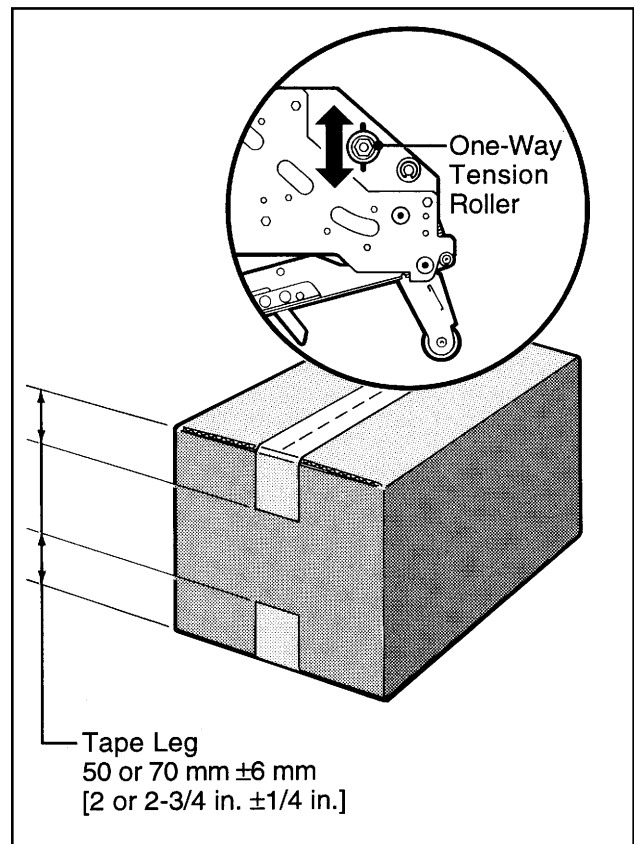

Figure 5-6 – Leading Tape Leg Length

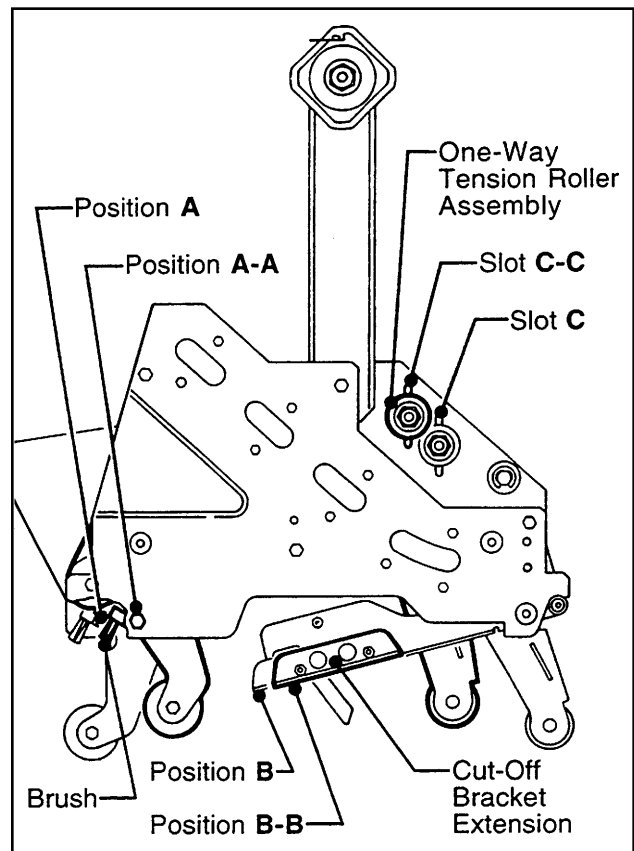

Figure 5-7 – Changing Tape Leg Length

Troubleshooting

Troubleshooting Guide

Problem	Cause	Correction
The tape leg on the front of the case is too long	The tape is threaded incorrectly	The tape must go around the wrap roller before going around the one-way tension roller
	The tape tension is too low	Adjust the one-way tension roller
	The knurled roller drags	Check for adhesive build-up between the knurled roller and its shaft. Clean and lubricate shaft. Remove all lubricant from roller surfaces.
	Tape tracks to one side or drags on the support tabs of applying frame	Adjust the tape web alignments
	The one-way tension roller is not correctly positioned	Position the roller in its mounting slot so that the tape extends just beyond the centerline of the applying roller
	Taping head is not set up properly	Check leg length adjustments
The blade does not cut tape or the tape end is jagged or shredded	The blade is dull and/or has broken teeth	Replace the blade
	Tape tension is insufficient	Increase tape tension by adjusting the one-way tension roller
	Adhesive has built up on the blade	Clean and adjust the blade
	The blade is not positioned properly	Make sure the blade is bottomed out against the mounting bolts
	The blade is dry	Lubricate the blade oiler pad on the blade guard
	The blade is in backwards	Mount the blade so that the beveled edge is away from the entrance of the head
	One or both cutter springs are missing or stretched	Replace the defective spring(s)
	Tension roller surface is not fully contacting the taping head frame	Make sure one-way bearing is below the surface of the tension roller. If not, press bearing further into roller or replace roller.

(Continued)

Troubleshooting (Continued)

Troubleshooting Guide

Problem	Cause	Correction
Tape is tabbing on the trailing leg on the back of the box	There is excess tension on the tape drum assembly and/or the one-way tension roller assembly	Adjust the one-way tension roller and/or the tape drum assembly
	Rollers in the tape path do not rotate freely	Clean adhesive deposits from the surface, ends, and shafts of the rollers. Then lubricate roller shafts. Remove all lubricant from roller surfaces.
	The blade is not cutting tape properly	Refer to tape cutting problems
	The tape is threaded incorrectly	Rethread the tape
	Applying mechanism spring has too little tension	Move spring hook to next tighter hole
The tape end does not stay in application position in front of the applying roller	The tape is incorrectly threaded	Rethread the tape
	Flanged knurled roller overruns on return of applying mechanism to its rest position	Adjust tension roller position in mounting slot to lengthen tape leg
	Applying roller overruns on return of applying mechanism to its rest position	There should be a slight drag when rotating the applying roller. If not, check friction springs and/or friction pins and replace if necessary
	The one-way tension roller is not correctly positioned	Position roller in its mounting slot so that tape end extends beyond centerline of applying roller
	The one-way tension roller is defective	Replace the one-way tension roller
Tape not centered on box seam	Tape drum not centered	Reposition tape drum
	Centering guides not centered	Adjust centering guides
	Box flaps not of equal length	Check box specifications

Spare Parts/Service Information

Recommended Spare Parts

A set of spare parts that will periodically require replacement due to normal wear is supplied with the taping heads. The set includes the following which should be reordered when used to keep the taping heads in production:

AccuGlide™ 2+ STD 3 Inch Upper Taping Head

Qty.	Ref. No.	Part Number	Description
4	10398-22	78-8076-4500-3	Stud – Mounting
1	10388-10	78-8070-1274-1	Spring – Upper Extension (Silver)
1	10392-2	78-8028-7899-7	Knife – 89 mm/3.5 Inch
2	10392-12	78-8052-6602-6	Spring – Cutter
1	–	78-8076-4726-4	Tool – Tape Threading

AccuGlide™ 2+ STD 3 Inch Lower Taping Head

Qty.	Ref. No.	Part Number	Description
1	10392-2	78-8028-7899-7	Knife – 89 mm/3.5 Inch
2	10392-12	78-8052-6602-6	Spring – Cutter
4	10400-22	78-8076-4500-3	Stud – Mounting
1	10390-10	78-8070-1273-3	Spring – Lower Extension (Black)
1	–	78-8076-4726-4	Tool – Tape Threading

In addition to the above set of spare parts supplied with the taping head, it is suggested that the following spare parts be maintained which will require replacement under normal wear of the taping head.

Qty.	Ref. No.	Part Number	Description
1	10394-15	78-8057-6181-0	Roller – Applying
1	10388/10390-5	78-8057-6180-2	Roller – Buffing
1	10392-18	78-8113-7030-9	Spring – Torsion

Replacement Parts and Service

Refer to the first page of this instruction manual “**Replacement Parts and Service Information.**”

Replacement Parts Illustrations and Parts Lists

AccuGlide™ 2+ STD 3 Inch Upper Taping Head, Type 10500

AccuGlide™ 2+ STD 3 Inch Lower Taping Head, Type 10500

1. Refer to the **Taping Head Assemblies** Figure to find all the parts illustrations identified by **figure numbers**.
2. Refer to the figure or figures to determine the **individual parts** required and the **parts reference number**.
3. The **replacement parts list**, that follows each illustration, includes the **part number** and **part description** for the parts in that illustration.

***Note** – The complete description has been included for standard fasteners and some commercially available components. This has been done to allow obtaining these standard parts locally, should the customer elect to do so.*

4. Refer to the first page of this instruction manual "**Replacement Parts and Service Information**" for replacement parts ordering information.

IMPORTANT – Not all the parts listed are normally stocked items. Some parts or assemblies shown are available only on a special order basis. Contact 3M/Tape Dispenser Parts to confirm item availability.

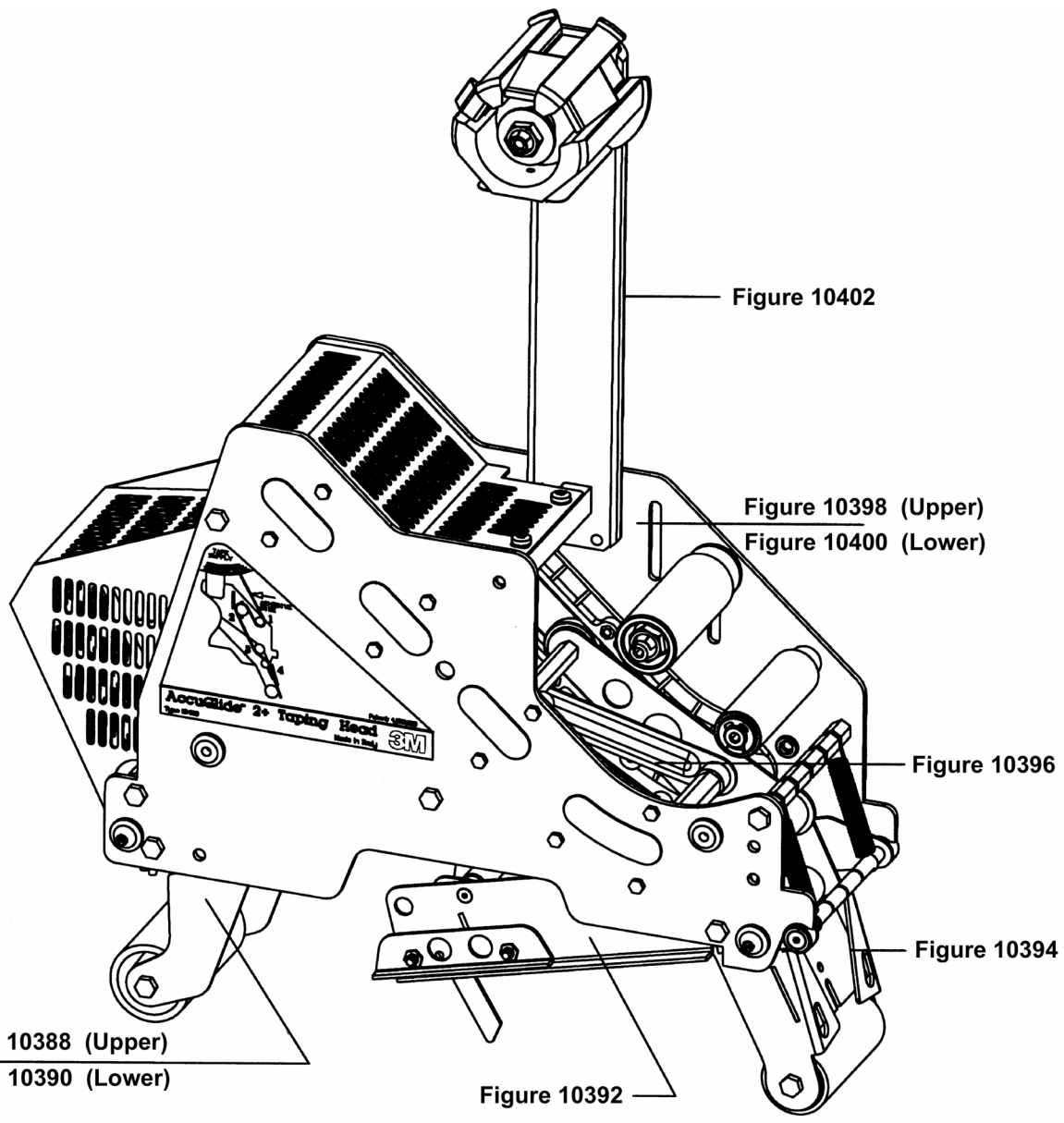

Taping Head Assemblies - AccuGlide™ 2+ STD 3 Inch

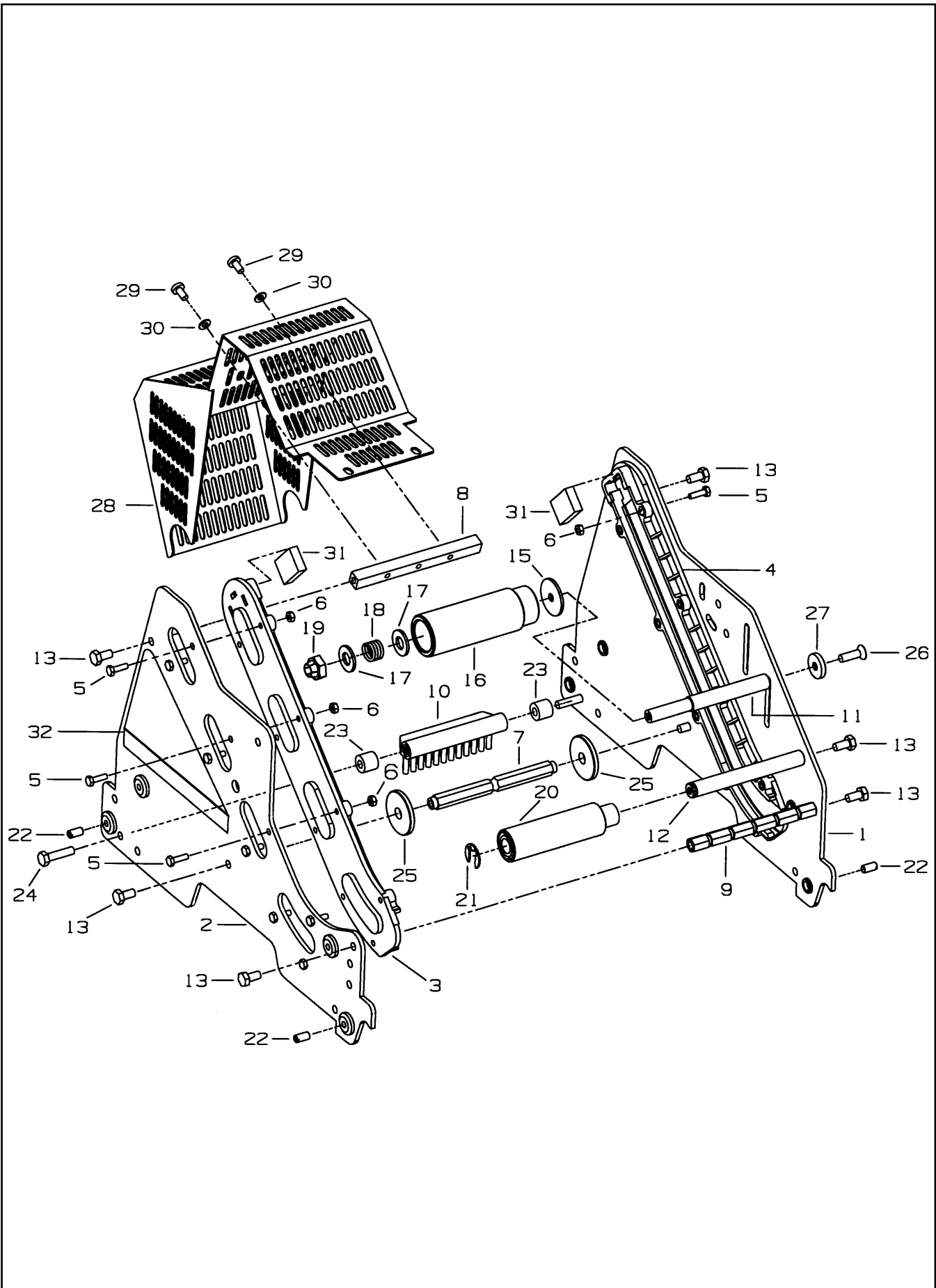

Figure 10398 – Upper Head

Figure 10398 – Upper Head

Ref. No.	3M Part No.	Description
10398-1	78-8133-9456-2	Frame – Tape Mount Upper Assembly
10398-2	78-8133-9458-8	Frame – Front Upper Assembly
10398-3	78-8068-4143-9	Guide – #1
10398-4	78-8068-4144-7	Guide – #2
10398-5	78-8060-7818-0	Screw – Hex Hd, M4 x 12
10398-6	78-8010-7416-8	Nut – Hex Jam, M4
10398-7	78-8076-4735-5	Spacer – Spring
10398-8	78-8055-0694-2	Spacer – 10 x 10 x 115 mm
10398-9	78-8060-7939-4	Spacer – 10 x 115 W/Slots
10398-10	78-8060-7936-0	Brush Assembly
10398-11	78-8054-8796-0	Shaft – Tension Roller
10398-12	78-8054-8798-6	Shaft – Wrap Roller
10398-13	26-1003-5829-5	Screw – Hex Hd, M6 x 12
10398-15	78-8100-1009-6	Washer – Special
10398-16	78-8054-8797-8	Roller – Top Tension
10398-17	26-1004-5510-9	Washer – Plain, M10
10398-18	78-8052-6567-1	Spring – Compression
10398-19	78-8017-9077-1	Nut – Self Locking, M10 x 1
10398-20	78-8054-8799-4	Roller – Wrap
10398-21	26-1000-1613-3	Ring – Retaining, Tru-Arc #1-420-0120-100
10398-22	78-8076-4500-3	Stud – Mounting
10398-23	78-8060-7937-8	Spacer – 6,5/14 x 12,5
10398-24	78-8060-7938-6	Screw – Low Profile, M6 x 25
10398-25	78-8076-5242-1	Stop – Cut-Off Frame
10398-26	78-8060-8179-6	Screw – Flat Head Hex, M6 x 20
10398-27	78-8076-5477-3	Washer – Special, 6.5 x 20 x 4
10398-28	78-8100-1049-2	Guard – Head
10398-29	78-8060-8087-1	Screw – M5 x 10
10398-30	78-8005-5741-1	Washer – Flat, M5
10398-31	78-8133-9615-3	Bumper
10398-32	78-8133-9605-4	Label – Threading, English Language

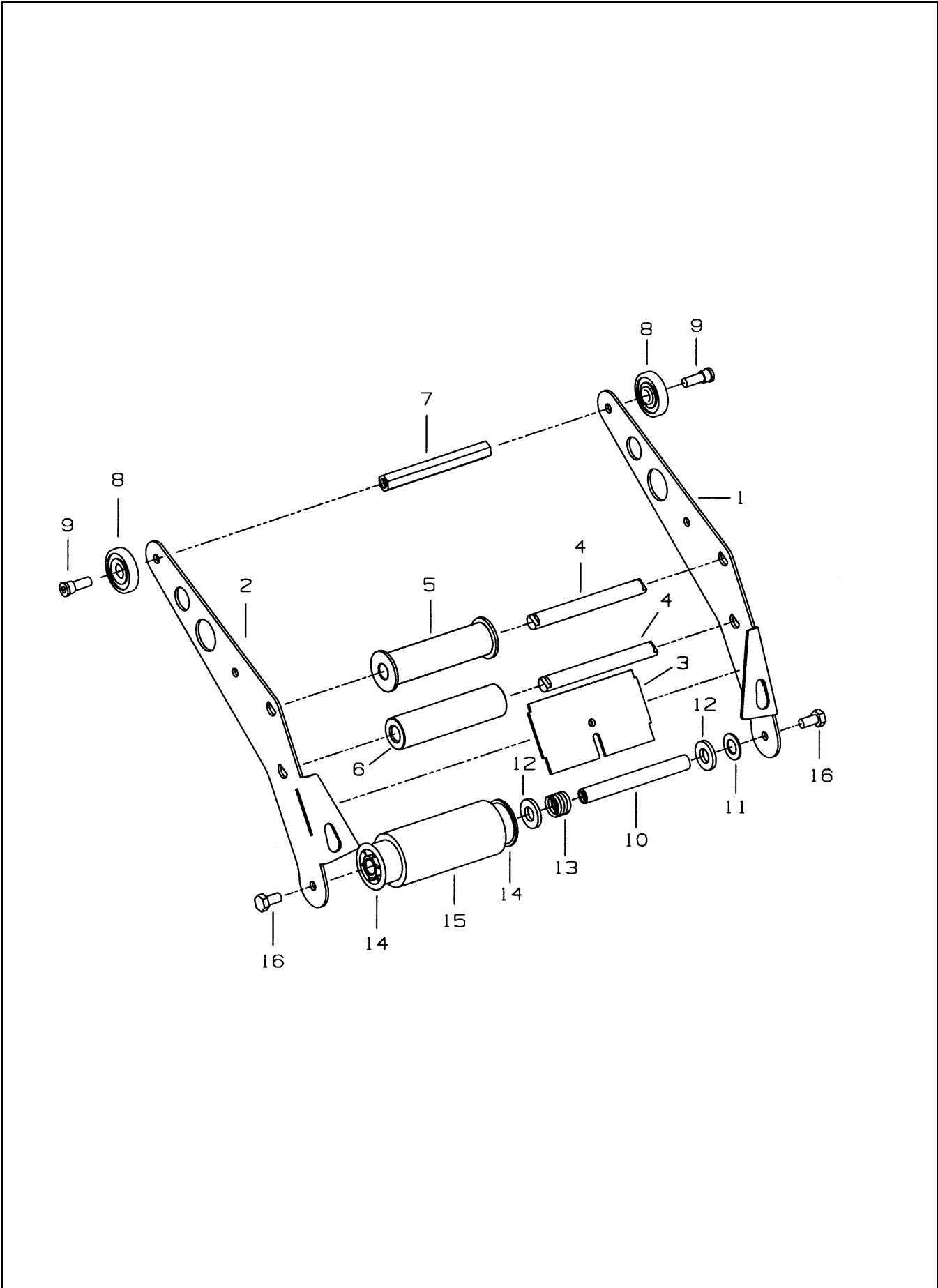

Figure 10394 – Upper and Lower Heads

Figure 10394 – Upper and Lower Heads

Ref. No.	3M Part No.	Description
10394-1	78-8133-9520-5	Arm – Applying, R/H
10394-2	78-8133-9521-3	Arm – Applying, L/H
10394-3	78-8070-1292-3	Plate – Back-Up
10394-4	78-8076-4736-3	Shaft Roller
10394-5	78-8076-4737-1	Roller Assembly – Knurled
10394-6	78-8076-4738-9	Roller – Wrap
10394-7	78-8054-8806-7	Spacer
10394-8	78-8017-9082-1	Bearing – Special, 30 mm
10394-9	78-8017-9106-8	Screw – Bearing Shoulder
10394-10	78-8054-8801-8	Shaft – 10 x 85, W/Hexagon
10394-11	78-8017-9074-8	Washer – Nylon, 15 mm
10394-12	78-8052-6566-3	Washer – Friction
10394-13	78-8052-6567-1	Spring – Compression
10394-14	78-8060-8396-6	Bushing – Applying Roller
10394-15	78-8057-6181-0	Roller – Applying
10394-16	26-1003-5829-5	Screw – Hex Hd, M6 x 12

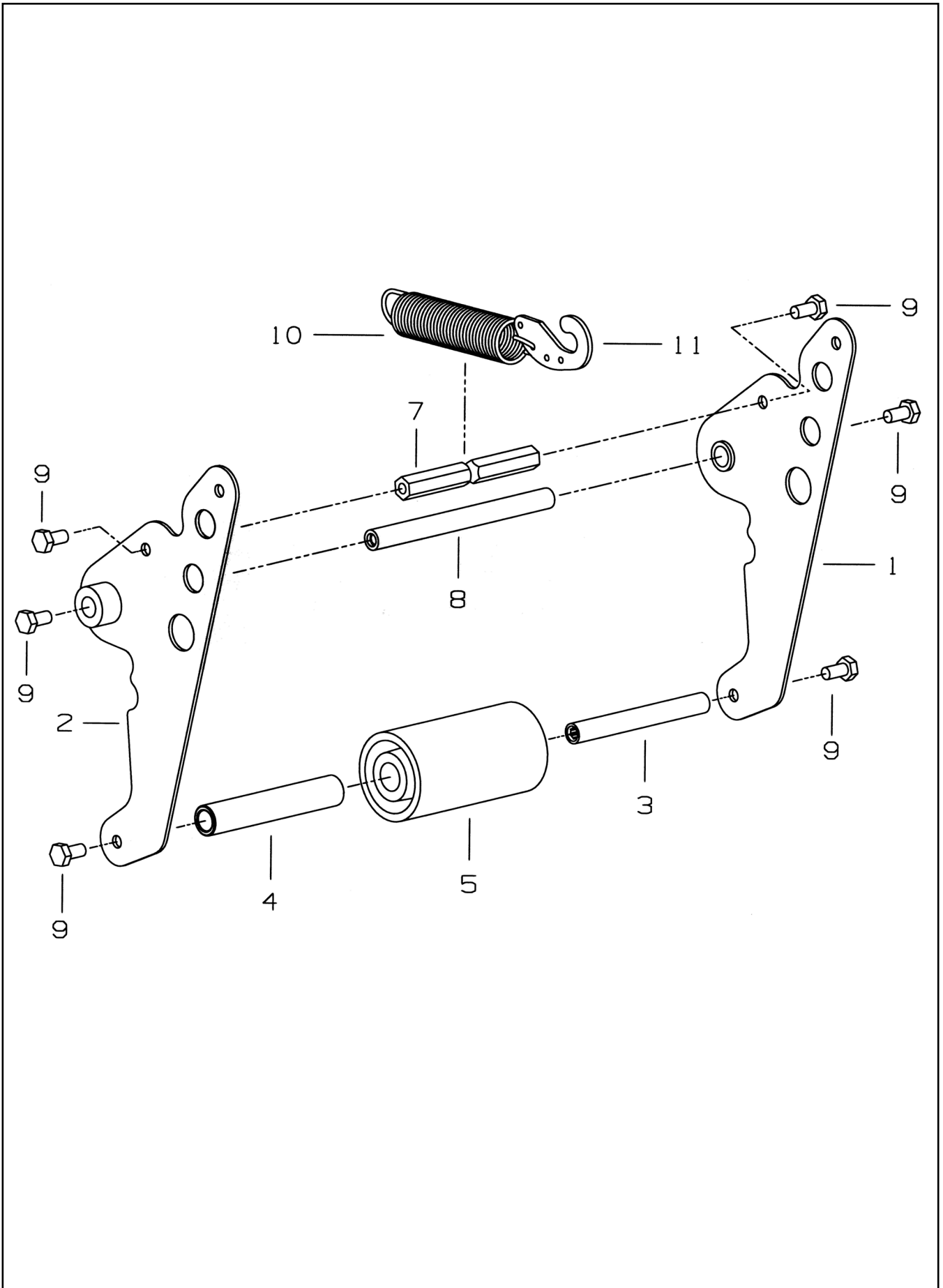

Figure 10388 – Upper Head

Figure 10388 – Upper Head

Ref. No.	3M Part No.	Description
10388-1	78-8070-1392-1	Buffing Arm – Sub Assembly
10388-2	78-8070-1391-3	Buffing Arm – Sub Assembly
10388-3	78-8091-0799-4	Shaft – 10 x 85, W/Hexagon
10388-4	78-8054-8807-5	Bushing – Buffing Roller
10388-5	78-8057-6180-2	Roller – Buffing
10388-7	78-8076-4739-7	Spacer – Spring
10388-8	78-8028-7885-6	Shaft – 10 x 115 mm
10388-9	26-1003-5829-5	Screw – Hex Hd, M6 x 12
10388-10	78-8070-1274-1	Spring – Upper (Silver)
10388-11	78-8070-1244-4	Holder – Spring

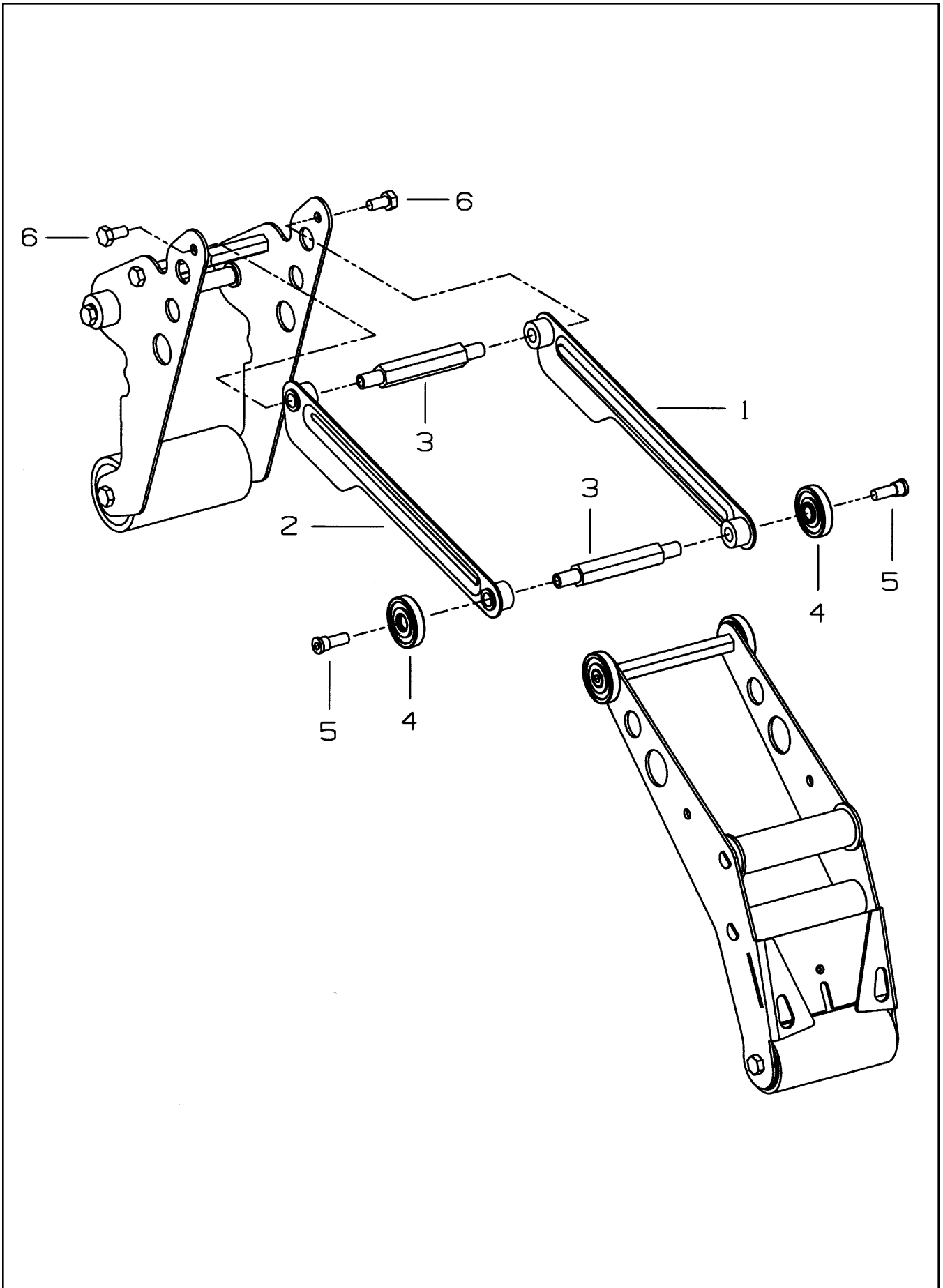

Figure 10396 – Upper and Lower Heads

Figure 10396 – Upper and Lower Heads

Ref. No.	3M Part No.	Description
10396-1	78-8070-1388-9	Link – Arm Bushing Assembly
10396-2	78-8070-1389-7	Link – Arm Bushing Assembly
10396-3	78-8076-4740-5	Shaft – Pivot
10396-4	78-8017-9082-1	Bearing – Special 30 mm
10396-5	78-8017-9106-8	Screw – Bearing Shoulder
10396-6	26-1003-5829-5	Screw – Hex Hd, M6 x 12

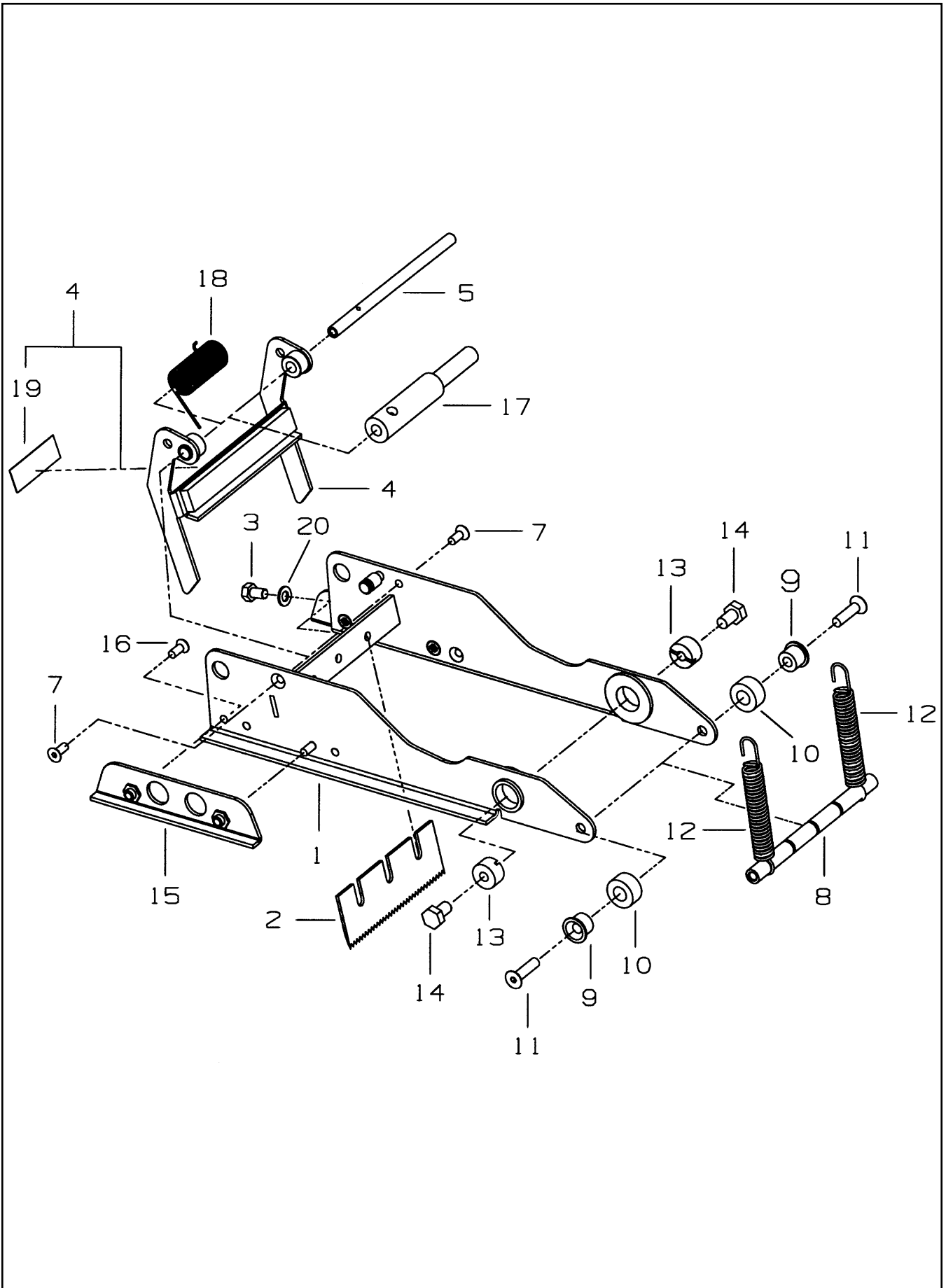

Figure 10392 – Upper and Lower Heads

Figure 10392 – Upper and Lower Heads

Ref. No.	3M Part No.	Description
10392-1	78-8070-1283-2	Frame – Cut-Off
10392-2	78-8028-7899-7	Knife – 89 mm/3.5 Inch
10392-3	26-1002-5817-2	Screw – Hex Hd, M5 x 8
10392-4	78-8076-4741-3	Knife Guard Assembly – W/English Language Label
10392-5	78-8054-8813-3	Shaft – Knife Guard
10392-7	26-1005-4758-2	Screw – Flat Hd, Soc Dr, M4 x 10
10392-8	78-8060-7941-0	Pin – Spring Holder W/Slots
10392-9	78-8052-6600-0	Spacer
10392-10	78-8070-1269-1	Bumper
10392-11	26-1005-4757-4	Screw – Flat Hd, Soc Dr, M5 x 20
10392-12	78-8052-6602-6	Spring – Cutter
10392-13	78-8017-9132-4	Pivot – Cutter Lever
10392-14	26-1003-5828-7	Screw – Spec, Hex Hd, M6 x 10
10392-15	78-8070-1216-2	Slide – Extension
10392-16	26-1008-6574-5	Screw – Flat Hd, Phil Dr, M4 x 10
10392-17	78-8113-7060-6	Bushing – 83.7 mm Long
10392-18	78-8113-7030-9	Spring – Torsion
10392-19	78-8070-1335-0	Label – Warning, English

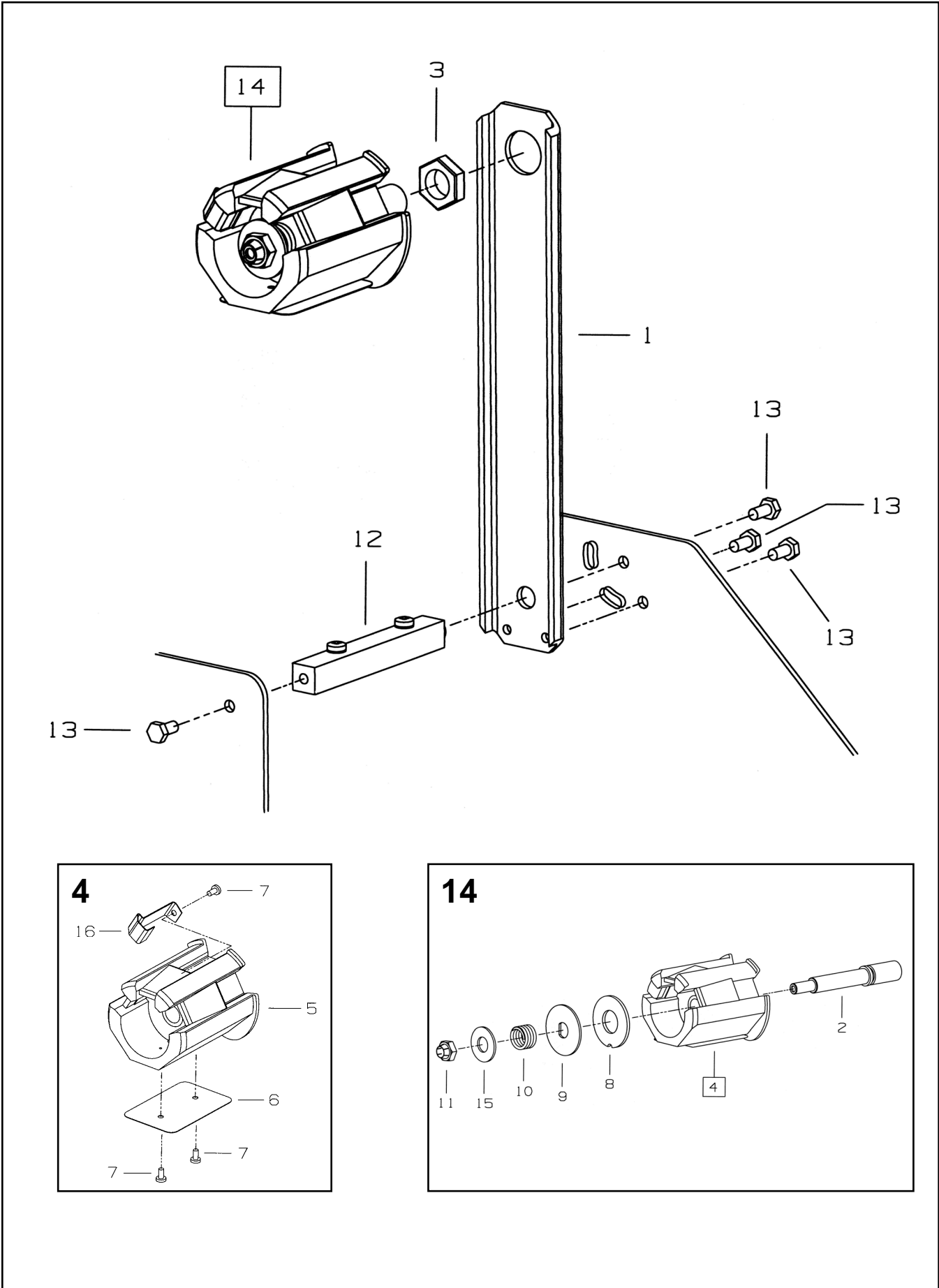

Figure 10402 – Upper and Lower Heads

Figure 10402 – Upper and Lower Heads

Ref. No.	3M Part No.	Description
10402-1	78-8070-1395-4	Bracket – Bushing Assembly
10402-2	78-8060-8462-6	Shaft – Tape Drum, 3 Inch Head
10402-3	78-8017-9169-6	Nut – M18 x 1
10402-4	78-8098-8829-6	Tape Drum Sub Assembly – 3 Inch Wide
10402-5	78-8098-8828-8	Tape Drum
10402-6	78-8098-8830-4	Leaf Spring
10402-7	26-1002-5753-9	Screw – Self Tapping
10402-8	78-8060-8172-1	Washer – Friction
10402-9	78-8052-6271-0	Washer – Tape Drum
10402-10	78-8100-1048-4	Spring – Core Holder
10402-11	78-8017-9077-1	Nut – Self Locking, M10 x 1
10402-12	78-8100-1050-0	Spacer – Bracket
10402-13	26-1003-5829-5	Screw – Hex Hd, M6 x 12
10402-14	78-8133-9641-9	Tape Drum Assembly – 3 Inch Head
10402-15	26-1004-5510-9	Washer – Plain, M10
10402-16	78-8098-8816-3	Latch – Tape Drum

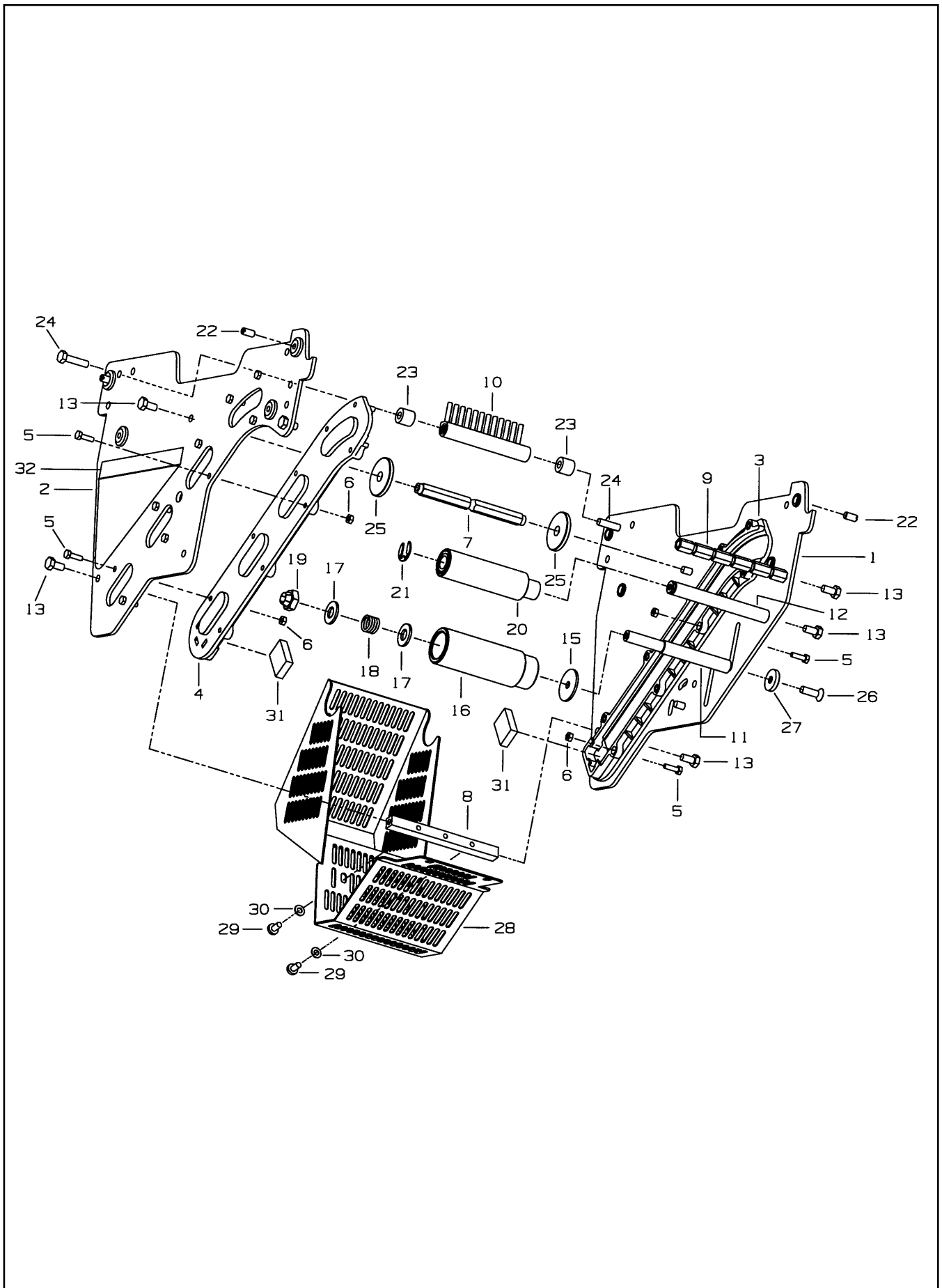

Figure 10400 – Lower Head

Figure 10400 – Lower Head

Ref. No.	3M Part No.	Description
10400-1	78-8133-9502-3	Frame – Tape Mount Lower Assembly
10400-2	78-8133-9500-7	Frame – Front Lower Assembly
10400-3	78-8068-4144-7	Guide – #2
10400-4	78-8068-4143-9	Guide – #1
10400-5	83-0002-7336-3	Screw – Hex Hd, M4 x 14
10400-6	78-8010-7416-8	Nut – Hex, M4
10400-7	78-8076-4735-5	Spacer – Spring
10400-8	78-8055-0694-2	Spacer – 10 x 10 x 115 mm
10400-9	78-8060-7939-4	Spacer – 10 x 115, W/Slots
10400-10	78-8060-7936-0	Brush Assembly
10400-11	78-8054-8796-0	Shaft – Tension Roller
10400-12	78-8054-8798-6	Shaft – Wrap Roller
10400-13	26-1003-5829-5	Screw – Hex Hd, M6 x 12
10400-15	78-8100-1009-6	Washer – Special
10400-16	78-8054-8817-4	Roller – Tension Bottom
10400-17	26-1004-5510-9	Washer – Plain, M10
10400-18	78-8052-6567-1	Spring – Compression
10400-19	78-8017-9077-1	Nut – Self Locking, M10 x 1
10400-20	78-8054-8799-4	Roller – Wrap
10400-21	26-1000-1613-3	Ring – Retaining, Tru-Arc #1-420-0120-100
10400-22	78-8076-4500-3	Stud – Mounting
10400-23	78-8060-7937-8	Spacer – 6,5/14 x 12,5
10400-24	78-8060-7938-6	Screw – Low Profile, M6 x 25
10400-25	78-8076-5242-1	Stop – Cut-Off Frame
10400-26	78-8060-8179-6	Screw – Flat Head Hex, M6 x 20
10400-27	78-8076-5477-3	Washer – Special /6.5 x 20 x 4
10400-28	78-8100-1049-2	Guard – Head
10400-29	78-8060-8087-1	Screw – M5 x 10
10400-30	78-8005-5741-1	Washer – Flat, M5
10400-31	78-8076-4734-8	Bumper
10400-32	78-8133-9606-2	Label – Threading, English Language

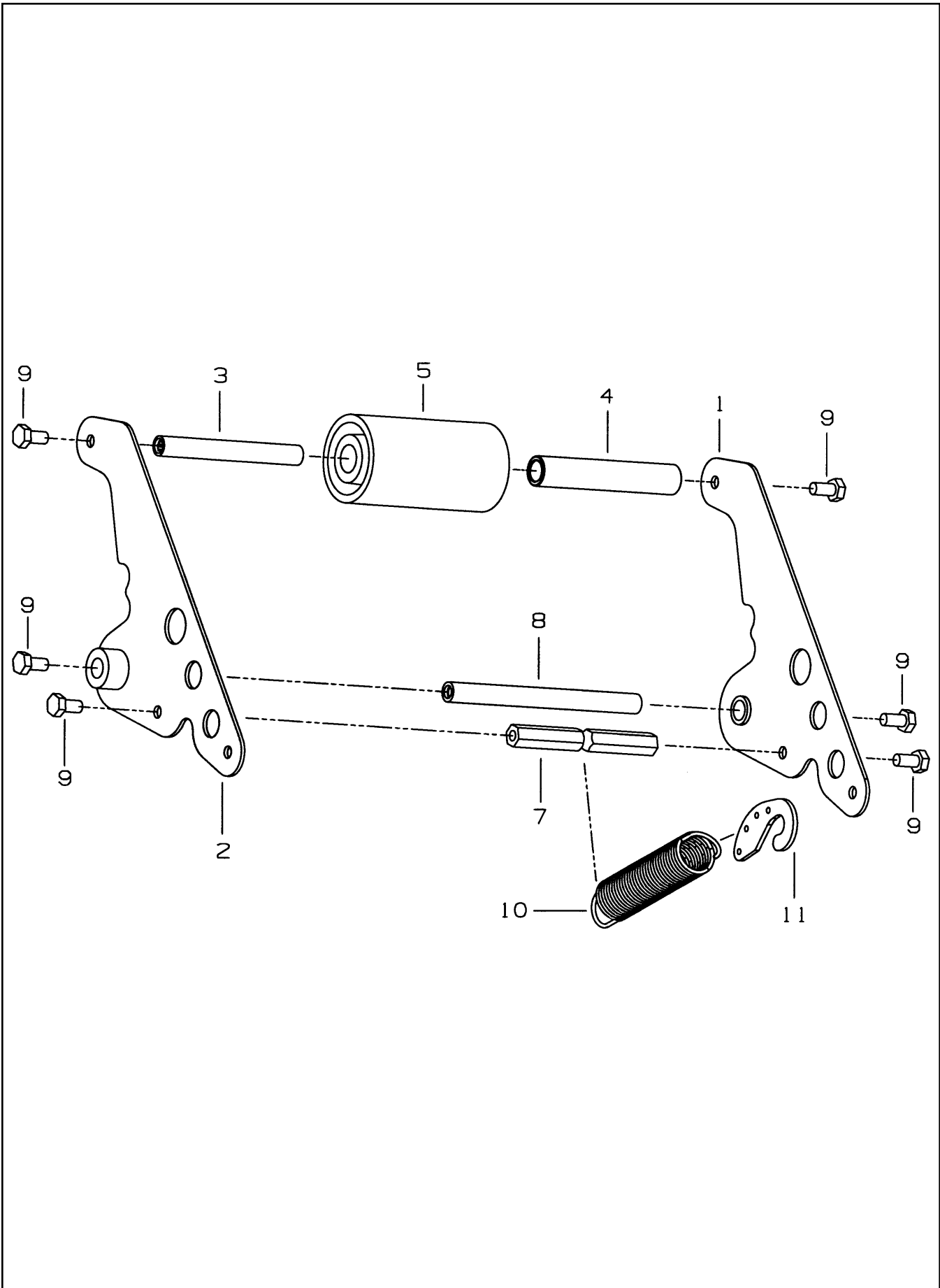

Figure 10390 – Lower Head

Figure 10390 – Lower Head

Ref. No.	3M Part No.	Description
10390-1	78-8070-1391-3	Buffing Arm Sub Assembly
10390-2	78-8070-1392-1	Buffing Arm Sub Assembly
10390-3	78-8091-0799-4	Shaft – 10 x 85, W/Hexagon
10390-4	78-8054-8807-5	Bushing – Buffing Roller
10390-5	78-8057-6180-2	Roller – Buffing
10390-7	78-8076-4739-7	Spacer – Spring
10390-8	78-8028-7885-6	Shaft – 10 x 115 mm
10390-9	26-1003-5829-5	Screw – Hex Hd, M6 x 12
10390-10	78-8070-1273-3	Spring – Lower (Black)
10390-11	78-8070-1244-4	Holder – Spring

THIS PAGE IS BLANK