



Aprisa XE



User Manual

April 2012

Version 8.6.77

Copyright

Copyright © 2012 4RF Limited. All rights reserved.

This document is protected by copyright belonging to 4RF Limited and may not be reproduced or republished in whole or part in any form without the prior written permission of 4RF Limited.

Trademarks

Aprisa and the 4RF logo are trademarks of 4RF Limited.

Windows is a registered trademark of Microsoft Corporation in the United States and other countries. Java and all Java-related trademarks are trademarks or registered trademarks of Sun Microsystems, Inc. in the United States and other countries. All other marks are the property of their respective owners.

GoAhead WebServer. Copyright © 2000 GoAhead Software, Inc. All Rights Reserved.

Disclaimer

Although every precaution has been taken preparing this information, 4RF Limited assumes no liability for errors and omissions, or any damages resulting from use of this information. This document or the equipment may change, without notice, in the interests of improving the product.

RoHS and WEEE Compliance

The Aprisa XE is fully compliant with the European Commission's RoHS (Restriction of Certain Hazardous Substances in Electrical and Electronic Equipment) and WEEE (Waste Electrical and Electronic Equipment) environmental directives.

Restriction of hazardous substances (RoHS)

The RoHS Directive prohibits the sale in the European Union of electronic equipment containing these hazardous substances: lead*, cadmium, mercury, hexavalent chromium, polybrominated biphenyls (PBBs), and polybrominated diphenyl ethers (PBDEs).

4RF Limited has worked with its component suppliers to ensure compliance with the RoHS Directive which came into effect on the 1st July 2006.

*The European Commission Technical Adaptation Committee (TAC) has exempted lead in solder for high-reliability applications for which viable lead-free alternatives have not yet been identified. The exemption covers communications network infrastructure equipment, which includes 4RF Limited Aprisa XE microwave radios.

End-of-life recycling programme (WEEE)

The WEEE Directive concerns the recovery, reuse, and recycling of electronic and electrical equipment. Under the Directive, used equipment must be marked, collected separately, and disposed of properly.

4RF Limited has instigated a programme to manage the reuse, recycling, and recovery of waste in an environmentally safe manner using processes that comply with the WEEE Directive (EU Waste Electrical and Electronic Equipment 2002/96/EC).

4RF Limited invites questions from customers and partners on its environmental programmes and compliance with the European Commission's Directives (sales@4RF.com).

Compliance General

The Aprisa XE digital radio predominantly operates within frequency bands that require a site license be issued by the radio regulatory authority with jurisdiction over the territory in which the equipment is being operated.

It is the responsibility of the user, before operating the equipment, to ensure that where required the appropriate license has been granted and all conditions attendant to that license have been met.

Changes or modifications not approved by the party responsible for compliance could void the user's authority to operate the equipment.

Equipment authorizations sought by 4RF Limited are based on the Aprisa XE radio equipment being installed at a fixed location and operated in a continuous point-to-point mode within the environmental profile defined by EN 300 019, Class 3.2. Operation outside these criteria may invalidate the authorizations and / or license conditions.

The term 'Terminal' with reference to the Aprisa XE User Manual, is a generic term for one end of a fixed point-to-point Aprisa XE link and does not confer any rights to connect to any public network or to operate the equipment within any territory.

Compliance ETSI

The Aprisa XE radio terminal is designed to comply with the European Telecommunications Standards Institute (ETSI) specifications as follows:

Radio performance	EN 302 217 Parts 1, 2.1, and 2.2
EMC	EN 301 489 Parts 1 & 4
Environmental	EN 300 019, Class 3.2
Safety	EN 60950

 An Aprisa XE radio terminal operating in the following frequency bands / channel sizes has been tested and is compliant to the ETSI radio specifications and suitably displays the CE logo.

Other bands are compliant to the same radio performance specifications as adapted by 4RF Limited and therefore may be used in regions where compliance requirements demand CE performance at other frequencies.

Frequency band	Channel size	Power input	Notified body
300 MHz 400 MHz	25 kHz, 50 kHz, 75 kHz, 125 kHz, 150 kHz, 250 kHz, 500 kHz, 1.0 MHz, 1.75 MHz, 3.50 MHz	12 VDC, 24 VDC, 48 VDC, 115/230 VAC	Notified Body 0678
600 MHz 700 MHz 800 MHz 900 MHz	500 kHz	12 VDC, 24 VDC, 48 VDC, 115/230 VAC	Notified Body 0678
1400 MHz	75 kHz, 150 kHz, 250 kHz, 500 kHz, 1.0 MHz, 1.75 MHz, 3.50 MHz, 7 MHz	12 VDC, 12 VDC LP, 24 VDC, 48 VDC, 115/230 VAC	
1800 MHz 2000 MHz 2500 MHz	250 kHz, 500 kHz, 1.0 MHz, 1.75 MHz, 3.50 MHz, 7 MHz, 14 MHz	12 VDC, 24 VDC, 48 VDC, 115/230 VAC	

Informal Declaration of Conformity

Dansk	Undertegnede 4RF Limited erklærer herved, at følgende udstyr Aprisa Radio overholder de væsentlige krav og øvrige relevante krav i direktiv 1999/5/EF.
Deutsch	Hiermit erklärt 4RF Limited, dass sich dieses Aprisa Radio in Übereinstimmung mit den grundlegenden Anforderungen und den anderen relevanten Vorschriften der Richtlinie 1999/5/EG befindet. (BMW i)
Dutch	Hierbij verklaart 4RF Limited dat het toestel Aprisa Radio in overeenstemming is met de essentiële eisen en de andere relevante bepalingen van richtlijn 1999/5/EG.
English	Hereby, 4RF Limited, declares that this Aprisa Radio equipment is in compliance with the essential requirements and other relevant provisions of Directive 1999/5/EC.
Español	Por medio de la presente 4RF Limited declara que el Aprisa Radio cumple con los requisitos esenciales y cualesquiera otras disposiciones aplicables o exigibles de la Directiva 1999/5/CE.
Σλληνας	ΜΕ ΤΗΝ ΠΑΡΟΥΣΑ 4RF Limited ΔΗΛΩΝΕΙ ΟΤΙ Aprisa Radio ΣΥΜΜΟΡΦΩΝΤΑΙ ΠΡΟΣ ΤΙΣ ΟΥΣΙΩΔΕΙΣ ΑΠΑΙΤΗΣΕΙΣ ΚΑΙ ΤΙΣ ΔΟΙΠΕΣ ΣΧΕΤΙΚΕΣ ΔΙΑΤΑΞΕΙΣ ΤΗΣ ΟΤΗΓΙΑΣ 1999/5/ΚΕ.
Français	Par la présente 4RF Limited déclare que l'appareil Aprisa Radio est conforme aux exigences essentielles et aux autres dispositions pertinentes de la directive 1999/5/CE.
Italiano	Con la presente 4RF Limited dichiara che questo Aprisa Radio è conforme ai requisiti essenziali ed alle altre disposizioni pertinenti stabilite dalla direttiva 1999/5/CE.
Português	4RF Limited declara que este Aprisa Radio está conforme com os requisitos essenciais e outras provisões da Directiva 1999/5/CE.
Suomalainen	4RF Limited vakuuttaa täten että Aprisa Radio tyyppinen laite on direktiivin 1999/5/EY oleellisten vaatimusten ja sitä koskevien direktiivin muiden ehtojen mukainen.
Svensk	Härmed intygar 4RF Limited att denna Aprisa Radio står i överensstämmelse med de väsentliga egenskapskrav och övriga relevanta bestämmelser som framgår av direktiv 1999/5/EG.

A formal Declaration of Conformity document is shipped with each Aprisa XE terminal.



Compliance FCC

The Aprisa XE radio terminal is designed to comply with the Federal Communications Commission (FCC) specifications as follows:

Radio performance / EMC (dependant on variant)	47CFR part 90 Private Land Mobile Radio Services 47CFR part 101 Fixed Microwave Services 47CFR part 27 Misc Wireless Communication Services 47CFR part 15 Radio Frequency Devices
Safety	EN 60950

Frequency band limits	Channel size	Power input	Authorization	FCC ID
421 MHz to 512 MHz	25 kHz	48 VDC	Part 90 Certification	UIPN0400025A0200A
932.5 MHz to 944 MHz	100 kHz, 200 kHz	24 VDC, 48 VDC, 110 VAC	Part 101 Verification	-
2314.5 MHz to 2317.5 MHz 2346.5 MHz to 2349.5 MHz	250 kHz, 500 kHz	24 VDC, 48 VDC, 110 VAC	Part 27 Certification	UIPN2500AAAA0200A

NOTE: This equipment has been tested and found to comply with the limits for a Class A digital device, pursuant to part 15 of the FCC Rules. These limits are designed to provide reasonable protection against harmful interference when the equipment is operated in a commercial environment. This equipment generates, uses, and can radiate radio frequency energy and, if not installed and used in accordance with the instruction manual, may cause harmful interference to radio communications. Operation of this equipment in a residential area is likely to cause harmful interference in which case the user will be required to correct the interference at his own expense.

Compliance Industry Canada

The Aprisa XE radio terminal is designed to comply with Industry Canada (IC) specifications as follows:

Radio performance (dependant on variant)	RSS-GEN RSS-119
EMC	This Class A digital apparatus complies with Canadian standard ICES-003
Safety	EN 60950

Frequency band limits	Channel size	Power input	Authorization	IC ID
932.5 MHz to 944 MHz	100 kHz, 200 kHz	24 VDC, 48 VDC, 110 VAC	RSS-119	6772A-N09AAACC
406.1 MHz to 430 MHz 450 MHz to 470 MHz	25 kHz, 75 kHz, 150 kHz	12 VDC 24 VDC, 48 VDC, 110 VAC	RSS-119	6772A-N04AAAECE

RF Exposure Warning



WARNING:

The installer and / or user of Aprisa XE radio terminals shall ensure that a separation distance as given in the following table is maintained between the main axis of the terminal's antenna and the body of the user or nearby persons.

Minimum separation distances given are based on the maximum values of the following methodologies:

1. Maximum Permissible Exposure non-occupational limit (B or general public) of 47 CFR 1.1310 and the methodology of FCC's OST/OET Bulletin number 65.
2. Reference levels as given in Annex III, European Directive on the limitation of exposure of the general public to electromagnetic fields (0 Hz to 300 GHz) (1999/519/EC). These distances will ensure indirect compliance with the requirements of EN 50385:2002.

Frequency (MHz)	Maximum power (dBm)	Maximum antenna gain (dBi)	Maximum power density (mW/cm ²)	Minimum separation distance (m)
400	+ 35	15	0.20	2.0
512	+ 35	15	0.26	1.8
715	+ 34	15	0.36	1.3
806	+ 34	28	0.40	5.6
890	+ 34	28	0.45	5.3
960	+ 34	28	0.48	5.1
1550	+ 34	33	0.78	7.2
2300	+ 34	37	1.00	10.0
2700	+ 34	38	1.00	11.2

Contents

1. Getting Started	15
2. Introduction	19
About This Manual	19
What It Covers	19
Who Should Read It	19
Contact Us	19
What's in the Box	19
Aprisa XE CD Contents	20
Accessory Kit	21
3. Preparation	23
Path Planning	23
Antenna Selection and Siting	23
Coaxial Feeder Cables	26
Link Budget	26
Site Requirements	27
Power Supply	27
Equipment Cooling	27
Earthing and Lightning Protection	28
4. About the Terminal	29
Introduction	29
Modules	30
Front Panel Connections and Indicators	31
Interface Card Types	32
5. Mounting and Installing the Terminal	33
Required Tools	33
Installing the Terminal	33
Installing the Antenna and Feeder Cable	34
External Alarms	35
Alarm Circuit Setup	35
Interface Cabling	36
Power Supplies	37
DC Power Supply	37
AC Power Supply	40
Safety Earth	42
Bench Setup	43

6.	Connecting to the Terminal	45
	Connecting to the Terminal's Setup Port	45
	Connecting to the Terminal's Ethernet Interface.....	48
	PC Requirements for SuperVisor	49
	PC Settings for SuperVisor	50
	IP Addressing of Terminals.....	53
	Network IP Addressing.....	54
	Same Subnet as the Local PC	54
	Different Subnet as the Local PC	55
7.	Managing the Terminal	57
	The Setup Menu	57
	SuperVisor	59
	SuperVisor Logging In	60
	SuperVisor Logging Out.....	61
	SuperVisor Main Screen.....	62
	Changing the Terminal's IP Address	64
	Setting Up Users.....	65
	User groups.....	65
	Adding a User	65
	Disabling a User.....	66
	Deleting a User	66
	Saving User Information	66
	Changing Passwords.....	67
	Viewing User Session Details.....	67
8.	Configuring the Terminal	69
	Configuring the RF Settings.....	69
	Modem Performance Settings.....	72
	Entering Basic Terminal Information	74
	Configuring the IP Settings.....	75
	Setting the Terminal Clocking.....	76
	Setting the Duplexer Parameters	79
	Setting the RSSI Alarm Threshold	80
	Configuring the External Alarms	81
	Configuring the External Alarm Inputs	81
	Configuring the External Alarm Outputs	83
	Configuring SNMP Settings	85
	SNMP Access Controls.....	86
	SNMP Trap Destinations	87
	Viewing the SNMP Traps.....	88
	Viewing the SNMP MIB Details	88
	Saving the Terminal's Configuration	89

9. Configuring the Traffic Interfaces	91
Viewing a Summary of the Interfaces	91
Configuring the Traffic Interfaces	92
Ethernet Switch	93
VLAN tagging	93
Quality of Service	96
Viewing the Status of the Ethernet Ports	100
Resetting the Ethernet Settings	100
Ethernet Port Startup	101
QJET Port Settings	102
Q4EM Port Settings	104
Loop Interface Circuits	107
DFXO / DFXS Loop Interface Circuits	107
E1 CAS to DFXS Circuits	110
DFXS to DFXS Hotline Circuits	110
DFXS Port Settings	112
DFXO Port Settings	120
QV24 Serial Interface Card	128
QV24 Port Settings	129
QV24S Port Settings	130
HSS Port Settings	133
HSS Handshaking and Clocking Modes	135
HSS Handshaking and Control Line Function	135
HSS Synchronous Clock Selection Modes	138

10. Cross Connections	145
Embedded Cross Connect Switch.....	145
Link Capacity Utilization	145
The Cross Connections Application	145
The Cross Connections System Requirements	145
Installing the Cross Connections Application	146
Opening the Cross Connections Application	146
The Cross Connections Page	147
Setting the Terminal's IP Address	149
Management and User Ethernet Capacity.....	150
Setting Card Types	151
Getting Cross Connection Configuration from the Terminals	151
Creating Cross Connections	152
Sending Cross Connection Configuration to the Terminals	155
Saving Cross Connection Configurations	155
Using Existing Cross Connection Configurations	155
Printing the Cross Connection Configuration.....	156
Deleting Cross Connections	157
Configuring the Traffic Cross Connections.....	158
Compatible Interfaces	158
QJET Cross Connections	159
Selecting and Mapping Bits and Timeslots	166
Q4EM Cross Connections.....	170
DFXS and DFXO Cross Connections	171
QV24 Cross Connections	172
QV24S Cross Connections.....	173
HSS Cross Connections	174
Cross Connection Example	175
Symmetrical Connection Wizard	176
Starting the Cross Connections Wizard.....	176
Cross Connections Wizard Navigation	176
Setting the Cross Connections IP Address.....	177
Setting the Cross Connections Bandwidth	177
Cross Connections Card Selection.....	178
Cross Connections Interface Configurations	179
Symmetrical Connection Summary.....	180
Send Symmetrical Connection Configuration.....	180
11. Protected Terminals	181
Monitored Hot Stand By (MHSB)	181
Tributary Switch Front Panel	182
RF Switch Front Panel	183
MHSB Cabling.....	185
MHSB Power Supply	185
Configuring the Radios for Protected Mode	186
Hitless Space Diversity (HSD)	190
HSD Terminal Cabling.....	191
HSD Terminal IP Addresses.....	192

12. In-Service Commissioning	197
Before You Start.....	197
What You Will Need.....	197
Applying Power to the Terminals.....	198
Review the Link Configurations Using SuperVisor.....	198
Antenna Alignment.....	199
Checking the Antenna Polarization.....	199
Visually Aligning Antennas.....	200
Accurately Aligning the Antennas.....	201
Checking Performance.....	203
Checking the Receive Input Level.....	203
Checking the Fade Margin.....	204
Checking the Long-Term BER.....	205
Bit Error Rate Tests.....	205
Additional Tests.....	206
Checking the Link Performance.....	207
Viewing a Summary of the Link Performance.....	208
Saving the History of the Link Performance.....	209
13. Maintenance	213
Routine Maintenance.....	213
Terminal Upgrades.....	214
Software Upgrade Process.....	215
Uploading the Root File System.....	216
Uploading the Motherboard Images.....	216
Identifying the Correct TFTP Upgrade Type.....	217
TFTP Upgrade Process Types.....	220
Uploading System Files.....	226
Viewing the Image Table.....	231
Changing the Status of an Image File.....	232
Rebooting the Terminal.....	233
Support Summary.....	234
Installing Interface Cards.....	235
Preparing the Terminal for New Interface Cards.....	236
Installing an Interface Card.....	238
Configuring a Slot.....	240
14. Troubleshooting	241
Loopbacks.....	241
RF Radio Loopback.....	241
Interface Loopbacks.....	242
Timeslot Loopbacks.....	243
Alarms.....	244
Diagnosing Alarms.....	244
Viewing the Alarm History.....	246
Saving the Alarm History.....	247
Viewing Interface Alarms.....	248
Clearing Alarms.....	249
Identifying Causes of Alarms.....	250
E1 / T1 Alarm Conditions.....	252
System Log.....	253
Checking the Syslog.....	253
Setting up for Remote Logging.....	255

15. Interface Connections	257
RJ-45 Connector Pin Assignments	257
Interface Traffic Direction	257
QJET Interface Connections	258
Ethernet Interface Connections	259
Q4EM Interface Connections	260
E&M Signalling Types	261
DFXS Interface Connections	263
DFXO Interface Connections	264
HSS Interface Connections	265
Synchronous cable assemblies	266
Cable WAN Connectors	272
QV24 Interface connections	273
QV24S Interface connections	273
16. Alarm Types and Sources	275
Alarm Types	275
Transmitter Alarms	275
Receiver Alarms	277
MUX Alarms	280
Modem Alarms	280
Motherboard Alarms	280
QJET Alarms	281
DFXO Alarms	281
DFXS Alarms	281
HSS Alarms	282
QV24 Alarms	282
External Alarm Inputs	282
Remote Terminal Alarms	282
Cross Connect Alarms	283
MHSB Alarms	283
HSD Alarms	283
Software Alarms	284
17. Country Specific Settings	285

18. Specifications	287
RF Specifications	287
ETSI.....	287
FCC	294
Industry Canada	297
Receiver Performance	301
Duplexers	301
Interface Specifications	302
Ethernet Interface	302
QJET Quad E1 / T1 Interface	303
Q4EM Quad 4 Wire E&M Interface.....	304
DFXO Dual Foreign Exchange Office Interface	305
DFXS Dual Foreign Exchange Subscriber Interface.....	307
QV24 Quad V.24 Serial Data Interface	309
QV24S Quad V.24 Serial Data Interface	309
HSS Single High Speed Synchronous Data Interface	310
External Alarm Interfaces.....	310
Auxiliary Interfaces	310
Power Specifications.....	311
AC Power Supply.....	311
DC Power Supply.....	311
Power Consumption	312
Protection System Specifications	314
MHSB Protection.....	314
HSD Protection.....	314
General Specifications.....	315
Environmental	315
Mechanical	315
ETSI Compliance.....	315
19. Product End Of Life	317
End-of-Life Recycling Programme (WEEE)	317
The WEEE Symbol Explained.....	317
WEEE Must Be Collected Separately	317
YOUR ROLE in the Recovery of WEEE.....	317
EEE Waste Impacts the Environment and Health	317
20. Abbreviations	319
21. Acknowledgments and Licensing	321
22. Commissioning Form	327
23. Index	329

1. Getting Started

This section is an overview of the steps required to commission a link in the field.

Phase 1: Pre-installation	
1. Confirm path planning.	Page 23
2. Ensure that the site preparation is complete: <ul style="list-style-type: none"> • Power requirements • Tower requirements • Environmental considerations, for example, temperature control • Rack space 	Page 26
3. Confirm the interface card configuration.	

Phase 2: Installing the terminals	
1. Before installing the terminal into the rack, check that all the required interface cards are fitted.	
Position and mount the terminal in the rack.	Page 33
2. Connect earthing to the terminal.	Page 28
3. Confirm that the: <ul style="list-style-type: none"> • Antenna is mounted and visually aligned. • Feeder cable is connected to the antenna. • Feeder connections are tightened to recommended level. • Tower earthing is complete. 	
4. Install lightning protection.	Page 28
5. Connect the coaxial jumper cable between the lightning protection and the terminal duplexer.	
6. Connect the power supply to the terminal and apply power.	Page 35

Phase 3: Establishing the link		
1.	<p>If you don't know the terminal's IP address :</p> <p>Connect the setup cable between the terminal's Setup port and the PC using accessory kit adaptor.</p> <p>Use HyperTerminal to confirm the IP settings for the terminal:</p> <ul style="list-style-type: none"> • Local IP address • Local subnet mask • Remote terminal IP address <p>Reboot the terminal</p>	Page 58
2.	Connect the Ethernet cable between the terminal's 4-port Ethernet switch and the PC.	
3.	<p>Confirm that the PC IP settings are correct for the 4-port Ethernet switch:</p> <ul style="list-style-type: none"> • IP address • subnet mask 	Page 50
4.	Confirm that Java is installed on the PC.	Page 49
5.	Start the web browser, and log into the terminal.	Page 60
6.	<p>Set or confirm the RF characteristics:</p> <ul style="list-style-type: none"> • TX and RX frequencies • Modulation type • TX output power 	Page 69
7.	Compare the actual RSSI to the expected RSSI value (from your path planning).	
8.	Fine-align the antennas.	Page 201
9.	Confirm that the terminal clock sources are set correctly.	Page 73
10.	Confirm that the TX and RX LEDs are green. Disregard the OK LED status for now.	

Phase 4: Configuring the traffic		
1.	Confirm that the interface hardware and software slot configurations match.	
2.	Confirm the interface card settings.	Page 92
3.	Open the Cross Connections application and configure the cross connections: <ul style="list-style-type: none"> • Download the configuration. • Confirm or modify the traffic cross connections. • Save the configuration to the terminal. • Activate the configuration. 	Page 146
4.	Save the configuration to disk and close the Cross Connections application.	Page 155
5.	Connect the connection of interface cables.	
6.	Confirm or adjust the terminal clocking for network synchronization, if required.	
7.	Test that the traffic is passing over the link as configured.	
8.	Confirm or configure the external alarm settings in SuperVisor.	Page 81
9.	Setup an external alarm connection cable, if required.	
10.	Reset any alarms and error counters.	Page 244
11.	Perform traffic pre-commissioning tests (optional)	
12.	Complete the commissioning form (at the back of the manual) and file.	Page 327

2. Introduction

About This Manual

What It Covers

This user manual describes how to install and configure Aprisa XE fixed point-to-point digital radio links. It specifically documents an Aprisa XE terminal running system software version 8.6.77.

It is recommended that you read the relevant sections of this manual before installing or operating the terminal.

Who Should Read It

This manual has been written for professional field technicians and engineers who have an appropriate level of education and experience.

Contact Us

If you experience any difficulty installing or using Aprisa XE after reading this manual, please contact Customer Support or your local 4RF representative.

Our area representative contact details are available from our website:

4RF Limited
26 Glover Street, Ngauranga
PO Box 13-506
Wellington 6032
New Zealand

E-mail	support@4rf.com
Web site	www.4rf.com
Telephone	+64 4 499 6000
Facsimile	+64 4 473 4447
Attention	Customer Services

What's in the Box

Inside the box you will find:

- Aprisa XE terminal
- Accessory kit
- Aprisa CD
- Aprisa XE Quick Start Guide
- Commissioning Form
- Configuration sheet

Aprisa XE CD Contents

The Aprisa XE CD contains the following:

Software

- The latest version of the terminal software (see 'Terminal Upgrades' on page 214)
- The Cross Connections application - required if you want to use the Cross Connections application offline (see 'Installing Cross Connections application' on page 146).
- Java VM - Java plug-in needed to run the Supervisor software.
- Web browsers - Mozilla Firefox and Internet Explorer are included for your convenience.
- Adobe™ Acrobat® Reader® which you need to view the PDF files on the Aprisa CD.

Documentation

- User manual – an electronic (PDF) version for you to view online or print.
- Product collateral – application overviews, product description, quick start guide, case studies, software release notes and white papers.

Tools

- Surveyor - a path propagation calculator developed by 4RF (see 'Path planning' on page 23).
- XEpower - a power consumption model program.

Accessory Kit

The accessory kit contains the following items:

Two mounting brackets and screws



Two interface slot blanking plates

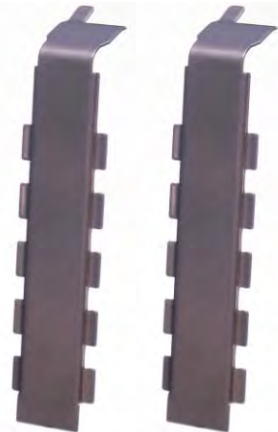

Setup cable (RJ-45 to RJ-45) 2 m
and RS-232 DB9 female adaptor

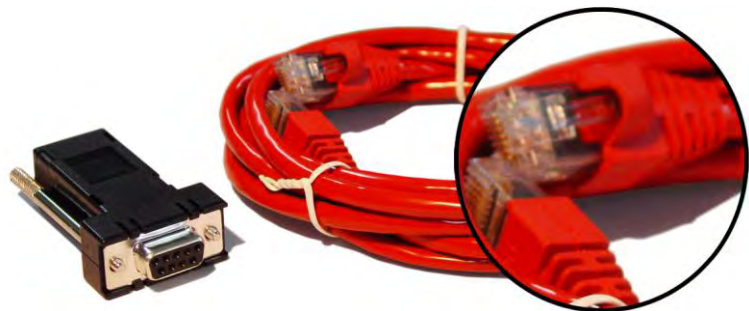

Hardware kit
(includes Allen key for fascia screws)



Alarm cable (RJ-45 to RJ-45) 5 m

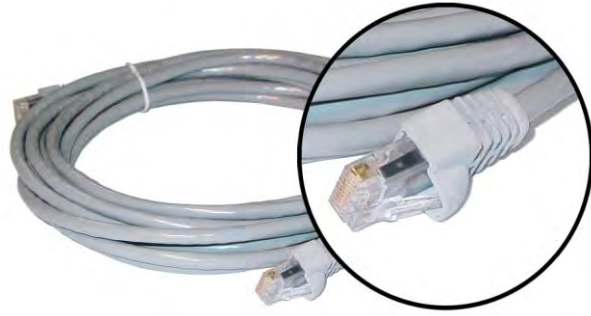

Ground cable 5 m



DC power cable 3 m
(for use with the ± 48 VDC, ± 24 and
12 VDC low power power supplies)



AC power cable 2 m
(for use with the 110 / 230 VAC
power supply)



3. Preparation

Path Planning

Proper path planning is essential. When considering the components of your radio system, think about:

- antenna selection and siting
- coaxial cable selection
- link budget

You can also use Surveyor to help you with path feasibility planning.

Surveyor is a path propagation calculator developed by 4RF to assist path planners quickly and efficiently verify the viability of point-to-point transmission links deploying the Aprisa microwave radio systems.

The software program calculates the anticipated link performance for the transmission system elements you have selected. However, it is not a substitute for in-depth path planning.

You will find Surveyor a valuable addition to your planning toolbox.

A copy of Surveyor is provided on the Aprisa CD supplied with this manual. You can download updates from www.4rf.com.

Antenna Selection and Siting

Selecting and siting antennas are important considerations in your system design.

There are three main types of directional antenna that are commonly used with the radios parabolic grid, Yagi and corner reflector antennas.

The antenna that should be used for a particular situation is determined primarily by the frequency of operation and the gain required to establish a reliable link.

Parabolic Grid Antennas

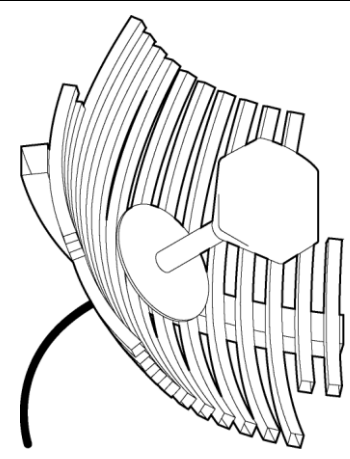
	Factor	Explanation
	Frequency	Often used in 1350-2700 MHz bands
	Gain	Varies with size (17 dBi to 30 dBi typical)
	Wind loading	Can be significant
	Tower aperture required	Can be significant
	Size	Range from 0.6 m to 3 m diameter
	Front to back ratio	Good
	Cost	High

Yagi Antennas

	Factor	Explanation
	Frequency	Often used in 330-960 MHz bands
	Gain	Varies with size (typically 11 dBi to 16 dBi)
	Stackable gain increase	2 Yagi antennas (+ 2.8 dB) 4 Yagi antennas (+ 5.6 dB)
	Wind loading	Less than a parabolic grid antenna
	Tower aperture required	Unstacked: Less than a parabolic grid antenna Stacked: about the same as a parabolic grid antenna
	Size	Range from 0.6 m to 3 m in length
	Front to back ratio	Low
	Cost	Low

It is possible to increase the gain of a Yagi antenna installation by placing two or more of them in a stack. The relative position of the antennas is critical.

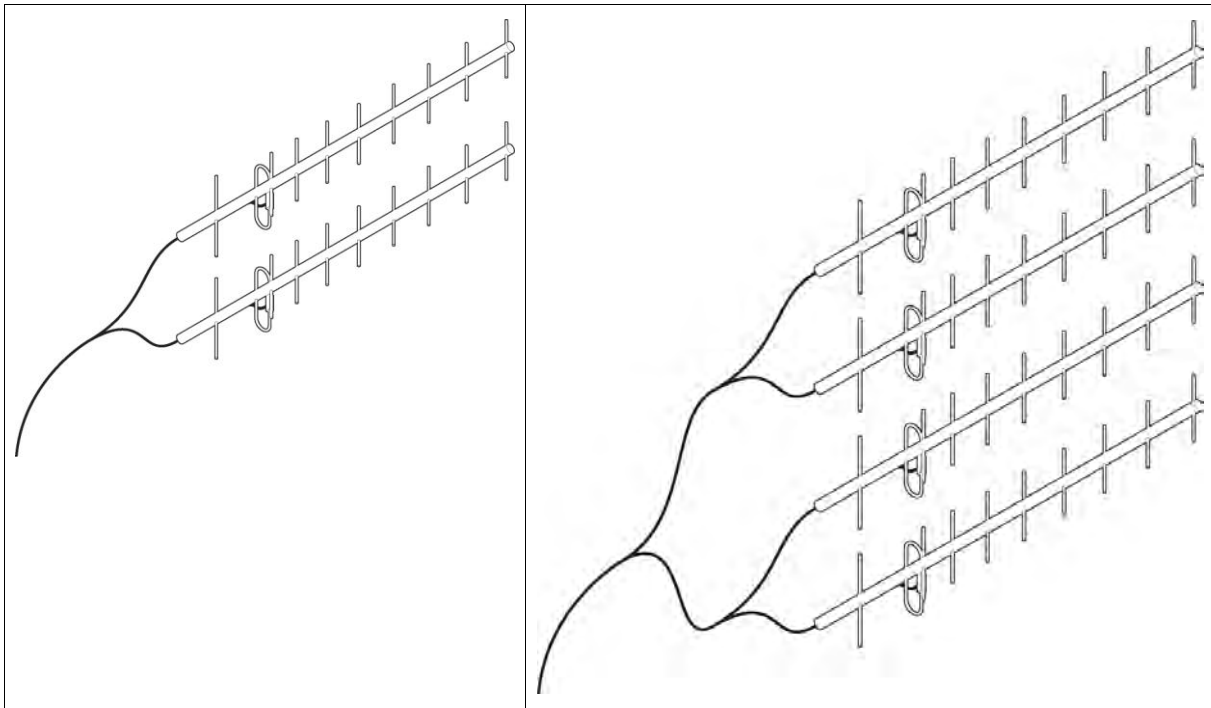

Example of stacked antennas

Corner Reflector Antennas

	Factor	Explanation
	Frequency	Often used in 330-960 MHz bands
	Gain	Typically 10 dBd
	Wind loading	Less than a parabolic grid antenna
	Tower aperture required	About the same as a parabolic grid antenna
	Size	Range from 0.36 m to 0.75 m in length
	Front to back ratio	High (typically 30 dB)
	Beamwidth	Broad (up to 60°)
	Cost	Medium

Antenna Siting

When siting antennas, consider the following points:

- A site with a clear line of sight to the remote terminal is needed. Pay particular attention to trees, buildings, and other obstructions close to the antenna site.

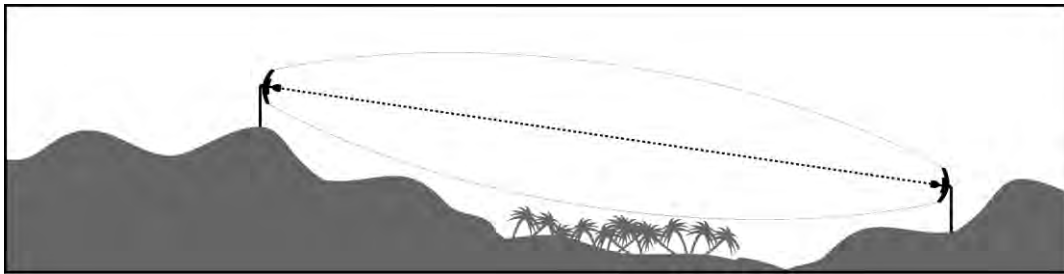

Example of a clear line-of-sight path

- Any large flat areas that reflect RF energy along the link path, for instance, water, could cause multipath fading. If the link path crosses a feature that is likely to cause RF reflections, shield the antenna from the reflected signals by positioning it on the far side of the roof of the equipment shelter or other structure.

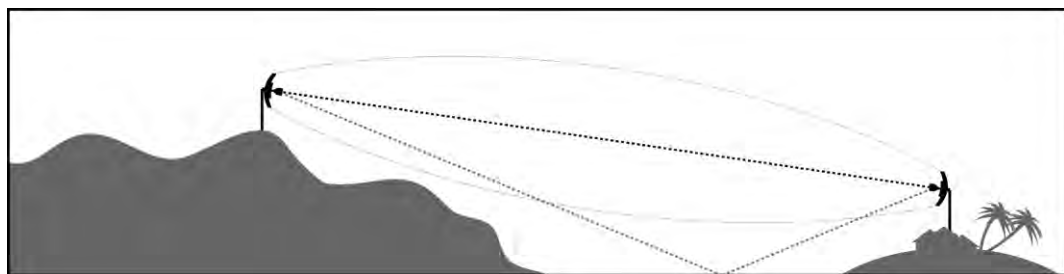

Example of a mid-path reflection path

- The antenna site should be as far as possible from other potential sources of RF interference such as electrical equipment, power lines and roads.
- The antenna site should be as close as possible to the equipment shelter.

Note: Wide angle and zoom photographs taken at the proposed antenna location (looking down the proposed path), can be useful when considering the best mounting positions.

Coaxial Feeder Cables

To ensure maximum performance, it is recommended that you use good quality low-loss coaxial cable for all feeder runs. For installations requiring long antenna cable runs, use Andrew Heliax™ or equivalent.

When using large diameter feeders, use a short flexible jumper cable between the feeder and the terminal to reduce stress on the antenna port connector.

All coaxial cable has loss, that is, the RF energy traveling through it is attenuated. Generally speaking, the larger the diameter of the cable, the less the loss. When selecting a coaxial cable consider the following:

Factor	Effect
Attenuation	Short cables and larger diameter cables have less attenuation
Cost	Smaller diameter cables are cheaper
Ease of installation	Easier with smaller diameter cables or short cables

When running cables:

- Run coaxial cable from the installation to the antenna, ensuring you leave enough extra cable at each end to allow drip loops to be formed.
- For 19-inch rack mount installations, cables may be run from the front of the rack directly onto the antenna port. They may also be run through the back of the rack to the front.
- Terminate and earth or ground the cables in accordance with the manufacturers' instructions. Bond the outer conductor of the coaxial feeder cables to the base of the tower mast.

Link Budget

All of the above factors (and many others not mentioned) combine in any proposed installation to create a link budget. The link budget predicts how well the radio link will perform after it is installed.

Use the outputs of the link budget during commissioning testing to confirm the link has been installed correctly, and that it will provide reliable service.

Site Requirements

Power Supply

Ensure that the correct power supply is available for powering the terminal.

The nominal input voltage for a terminal is 12, 24 or 48 volts DC or 115 / 230 volts AC rms.

The DC supply voltage is factory preset at time of order and cannot be adjusted in the field.

The terminal voltage is indicated on the chassis label by the DC input connector and on the specification label fitted to the terminal.

**WARNING:**

Before connecting power, ground the chassis using the safety earth terminal on the front panel.

Equipment Cooling

Mount the terminal so that air can flow through it. Do not obstruct the free flow of air around the terminal. The two internal, speed-controlled fans fitted into the chassis provide sufficient cooling.

The operation of the fans is monitored and an alarm is raised under failure conditions.

The environmental operating conditions are as follows:

Operating temperature	-10°C to +50°C
Storage temperature	-20°C to +70°C
Humidity	Maximum 95% non-condensing

Earthing and Lightning Protection



WARNING:

Lightning can easily damage electronic equipment.

To avoid this risk, install primary lightning protection devices on any interfaces that are reticulated in the local cable network.

You should also install a coaxial surge suppressor on the antenna port of the duplexer.

Earth the antenna tower, feeders and lightning protection devices in accordance with the appropriate local and national standards. The diagram below shows the minimum requirements.

Use grounding kits as specified or supplied by the coaxial cable manufacturer to properly ground or bond the cable outer.

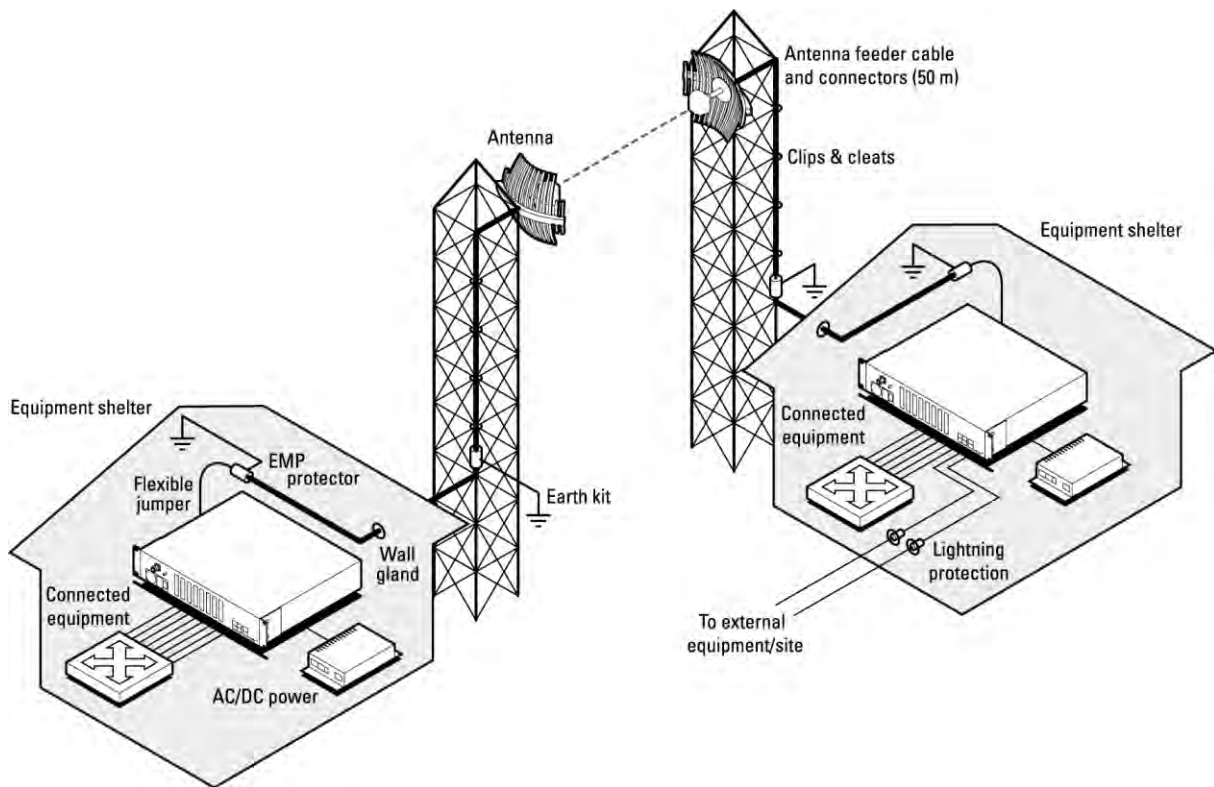

4. About the Terminal

Introduction

The terminals operate in a number of frequency bands from 300 MHz up to 2.7 GHz carrying ethernet, voice and data traffic over distances up to 100 kilometres.

They are designed to meet the demands of a wide range of low to medium capacity access and backhaul applications.

The digital access terminal is a compact, powerful point-to-point linking solution with up to 64 Mbit/s of radio link capacity, and customer-configurable interface options integrated within the radio platform.

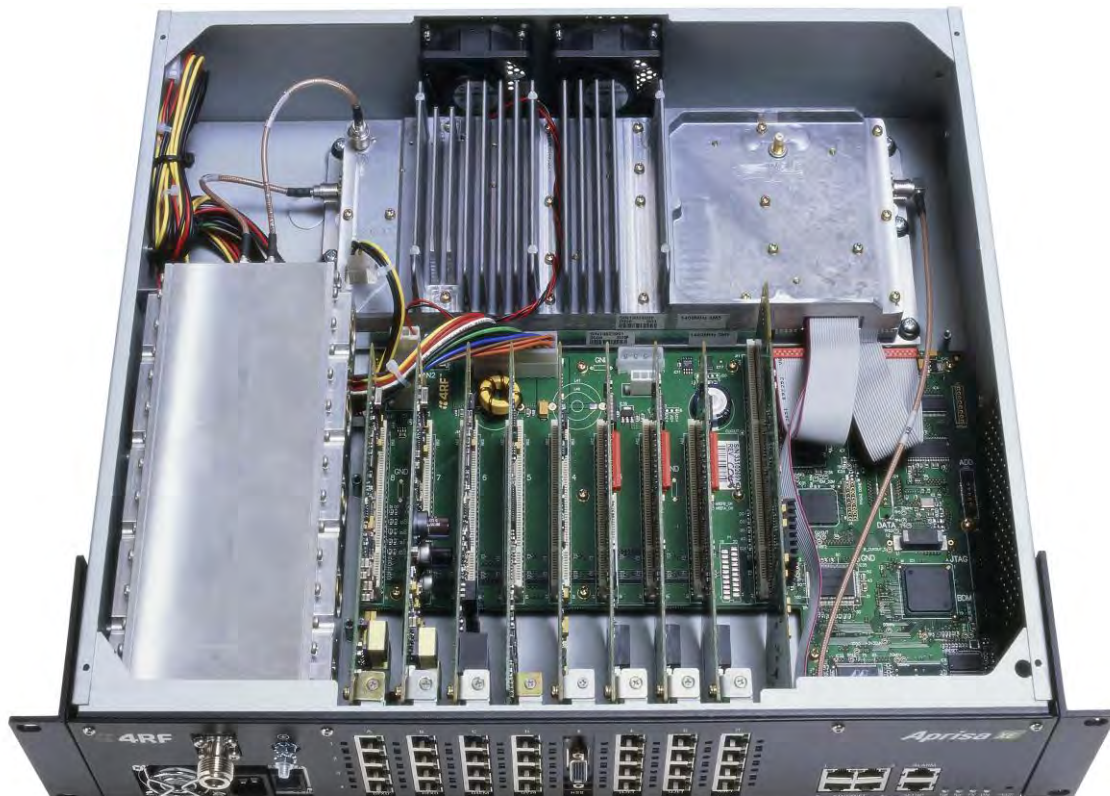

Modules

The terminal is modular in design, which helps reduce mean time to repair (MTTR). It is designed for 19-inch rack mounting and is only 2U high for standard configurations.

The five main modules housed inside the chassis are the transceiver, modem, motherboard, power supply, and duplexer. Interface cards are fitted into the eight interface slots on the motherboard. Modules are interconnected via several buses on the motherboard. A duplexer can be mounted inside or outside the chassis.



The interrelationships between the components are shown below:

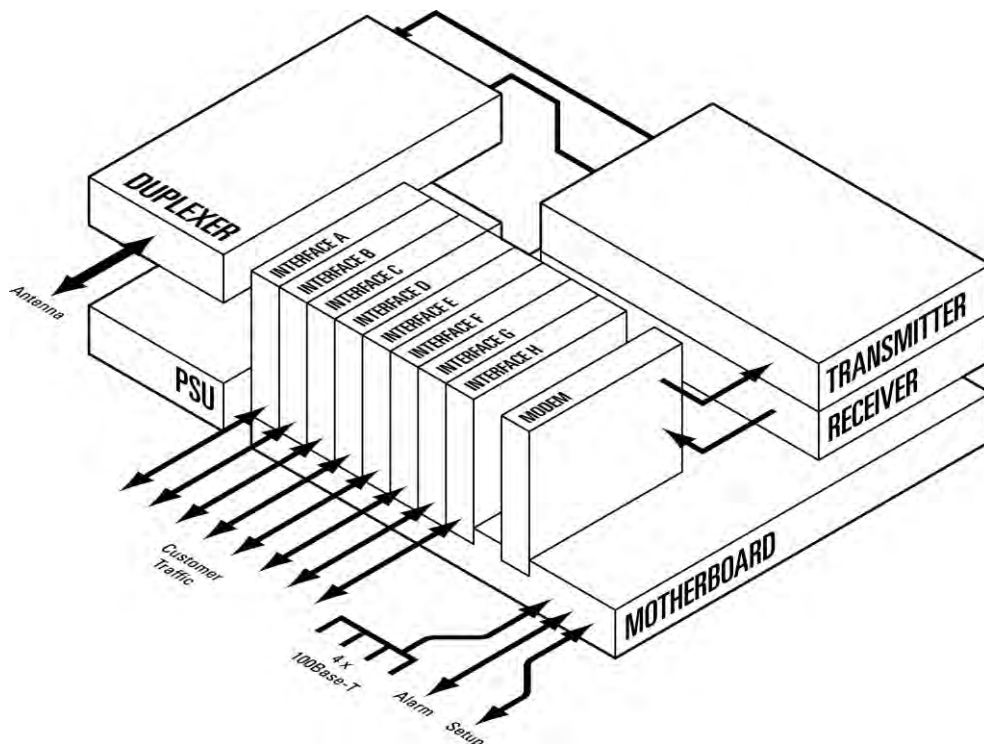

Front Panel Connections and Indicators

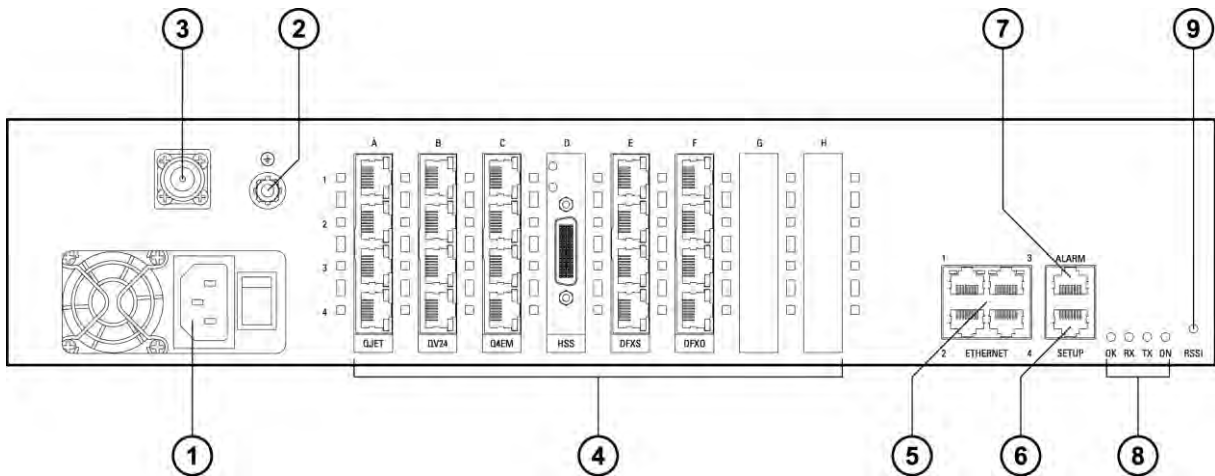

All connections to the terminal are made on the front panel of the terminal.

No.	Label	Description
1	AC or DC power input	DC and AC power supplies are available (AC is shown)
2	Safety earth stud	An M5 stud for connection to an external protection ground for protection against electric shock in case of a fault.
3	Antenna connector	N-type 50Ω female connector for connection of antenna feeder cable.
4	Interface slots A to H	Eight interface slots on the motherboard to fit interface cards.
5	ETHERNET	Integrated four-port layer 2 switch.
6	SETUP	RJ-45 serial connection to PC for initial configuration.
7	ALARM	RJ-45 connector for two external alarm input and four external alarm output connections.
8	LED indicators	
	OK	Indicates normal operation and minor and major alarm conditions.
	RX	Indicates status of receive path including normal operation and alarms such as BER, RSSI and loss of synchronization.
	TX	Indicates status of transmit path including normal operation and alarms such as forward / reverse power and temperature.
	ON	Blue LED indicates that there is power to the terminal.
9	RSSI	RSSI test point suitable for 2 mm diameter multimeter test lead pin.

Interface Card Types

Each terminal has eight interface slots labeled A to H. Each slot can be fitted with any interface card type. Typically, the terminal is delivered pre-configured with the requested interface cards.

The following interface card types are currently available:

Name	Interface card type	Function
QJET	Quad E1/T1 interface card	Four E1 / T1 interfaces (Framed or Unframed).
Q4EM	Quad 4 wire E&M interface card	Four 4 wire E&M voice channels
DFXS	Dual 2 wire FXS interface card	Two 2 wire loop signalling foreign exchange subscriber (POTS) channels
DFXO	Dual 2 wire FXO interface card	Two 2 wire loop signalling foreign exchange office channels
HSS	High-Speed Synchronous interface card	A single high speed serial data channel configured as synchronous V.24, V.35, X.21, V.36 / RS-449, or RS-530.
QV24	Quad V.24 serial interface card	Four V.24 / RS-232 serial data channels Synchronous and asynchronous

5. Mounting and Installing the Terminal

This section covers installing the hardware associated with the terminal. Before you begin a terminal installation, read this section thoroughly.

**CAUTION:**

You must comply with the safety precautions in this manual or on the product itself. 4RF Limited does not assume any liability for failure to comply with these precautions.

Required Tools

No special tools are needed to install the terminal other than those required to physically mount the terminal into the rack.

Installing the Terminal

The terminal is designed for 19-inch rack mounting and is supplied with rack mounting brackets. The rack brackets can be front, mid, or rear mounted (as shown below) to suit individual installation requirements. Once the rack brackets are attached, carefully lift the terminal into position in the rack, and fasten with screws and washers.

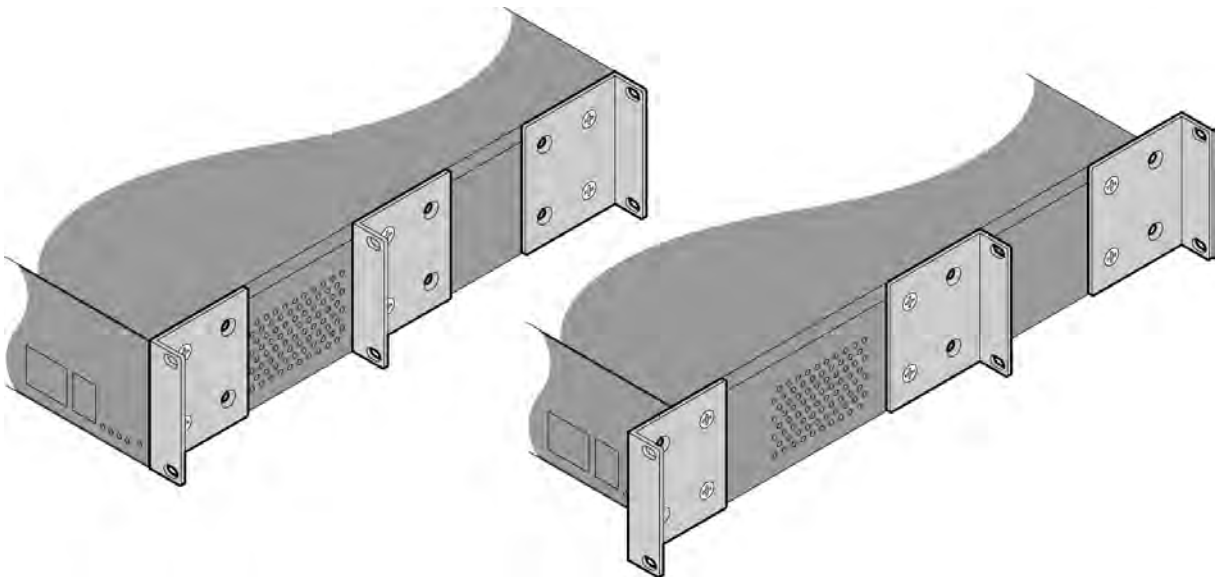

Installing the Antenna and Feeder Cable

Carefully mount the antenna following the antenna manufacturers' instructions. Run feeder cable from the antenna to the terminal mounting location.

Lightning protection must be incorporated into the antenna system. For more information, please contact Customer Support.



WARNING:

When the link is operating, there is RF energy radiated from the antenna. Do not stand in front of or touch the antenna while the terminal is operating.

1. Fit the appropriate male or female N-type connector to the antenna feeder at the antenna end. Carefully follow the connector manufacturers' instructions.
2. Securely attach the feeder cable to the mast and cable trays using cable ties or cable hangers. Follow the cable manufacturer's recommendations about the use of feeder clips, and their recommended spacing.
3. Connect the antenna and feeder cable. Ensure the N-type connector is tight. Weatherproof the connection with a boot, tape, or other approved method.
4. Fit the appropriate N-type male connector to the antenna feeder at the terminal end (the terminal is N-type female). Carefully follow the connector manufacturer's instructions.
5. Connect the feeder cable to the antenna port on the terminal. Use a jumper cable, if needed. Ensure the N-type connector is tight.
6. Connect a coaxial surge suppressor or similar lightning protector between the feeder and jumper cables (or at the point where the cable enters the equipment shelter).

Earth the case of the lightning protector to the site Lightning Protection Earth. Also earth the terminal M5 earth stud to a protection earth.

External Alarms

Two external alarm inputs and four external alarm outputs are provided on the RJ-45 ALARM connector on the front panel. These enable an internal alarm to provide an external alarm to the network operator's existing network management system via contact closure or opening, or for an external alarm to be transported via the radio link.

The latency for an alarm presented on an external alarm input to the alarm being output on an external alarm output is < 2 seconds.

Alarm outputs are isolated semiconductor relay type contacts rated 0 to 60 VDC or AC rms with a maximum current of 100 mA.

Alarm inputs are isolated current detectors with an operating voltage range of 9 to 60 VDC or AC rms (effective current threshold of 5.0 to 6.5 mA constant current).

The common reference potential for the two external alarm inputs must be applied to pin 3 and the common reference potential for the four external alarm outputs must be applied to pin 4.

Alarm Circuit Setup

A typical alarm circuit setup is:

- An external battery applied to the 'common alarm inputs reference' and a normally open relay contact connected to the alarm input. Closing the contact applies the source to the alarm input detector which turns the alarm on (setup for 'alarm on when source on'). See 'Configuring the External Alarm Inputs' on page 81 for the setup options.
- An external earth applied to the 'common alarm outputs reference' and a ground contact detector connected to the alarm output. When the alarm is on (active), the external alarm output relay contact closes (setup for 'relay closed when alarm on'). See 'Configuring the External Alarm Outputs' on page 83 for the setup options.

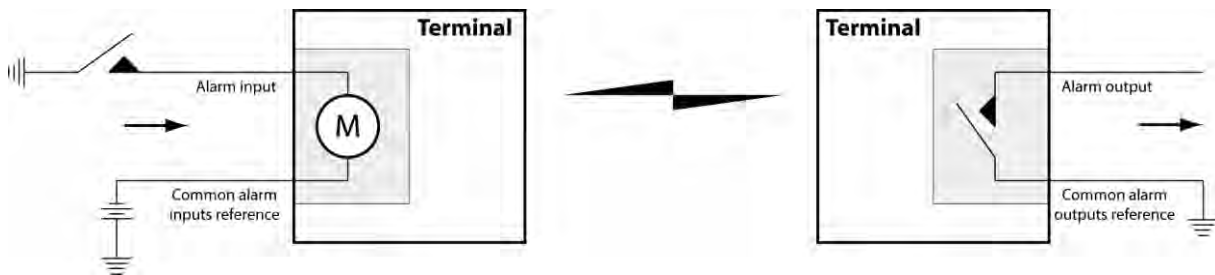

The terminal front panel RJ-45 ALARM connections are:

RJ-45 pin	Connection description	TIA-568A wire colour
1	External alarm input 1	green / white
2	External alarm input 2	green
3	Common reference for alarm inputs 1 to 2	orange / white
4	Common reference for alarm outputs 1 to 4	blue
5	External alarm output 1	blue / white
6	External alarm output 2	orange
7	External alarm output 3	brown / white
8	External alarm output 4	brown

Interface Cabling

All interface cabling connections are made with RJ-45 male connectors which plug into the front of the interface cards (see 'Interface Connections' on page 257).

QJET Q4EM DFXO and DFXS

The cabling to the QJET, Q4EM, DFXO and DFXS interface cards must have a minimum conductor size of 0.4 mm² (26 AWG).

Ethernet

Standard Ethernet network cables are used for all Ethernet port cabling.

Power Supplies

US and Canada: Installations should be in accordance with US National Electrical Code ANSI / NFPA 70, and Canadian Electrical Code, Part 1 C22.1.



WARNING:

Do not apply power to the terminal until you have completed installing the interface cards and connecting the antenna.

Before disconnecting the safety earth during maintenance, remove AC or DC power supply connections, antenna cable and all interface cables from the terminal.

DC Power Supply

There are four DC power supply options for the terminal; 12 VDC, 12 VDC Low Power, 24 VDC and 48 VDC. The DC inputs are polarity critical so the DC voltage must be applied with the correct polarity.

Nominal voltage	Input voltage range	Maximum Power input	Maximum input current	Recommended DC breaker rating
+12 VDC LP	10.5 to 18 VDC	53 W	5 A	8 A
±12 VDC	10.5 to 18 VDC	180 W	18 A	25 A
±24 VDC	20.5 to 30 VDC	180 W	8 A	10 A
±48 VDC	40 to 60 VDC	180 W	4 A	5 A

CAUTION: An all-pole switch or DC circuit breaker of the rating shown in the table above must be fitted between the terminal DC input and the DC power source.

Each terminal or MHSB terminal should have its own separate fuse or DC circuit breaker.

12 VDC / 24 VDC / 48 VDC Power Supply

The power supply DC input is isolated from ground, so the DC power input can be either positive grounded or negative grounded. The positive or negative terminal should be connected to ground.

12 VDC LP Power Supply

The 12 VDC Low Power is a high efficiency power supply for low power consumption applications up to a maximum of 53 watts input power (see ‘Power Consumption’ on page 312).

The DC input on this power supply is not isolated from ground as the negative input is internally connected to ground via the Aprisa XE chassis. The DC power input for this power supply must be a positive 12 V supply with the negative grounded.

DC Power Input Cabling

The DC power input is terminated on the front panel of the terminal with two high-current M3 screw clamps for the positive and negative DC input and a M5 stud for the earth connection.

The DC power cables have pre-terminated lugs to fit into the power input M3 screw clamps on one end and bare wire at the other end.

The appropriate power cable for the power supply ordered is included in the accessory kit.

12 VDC LP / 24 VDC / 48 VDC Cable

The 12 VDC LP, 24 VDC and 48 VDC power supplies are supplied with a 3 metre red / black cable of 2.0 mm² (23 strands of 0.32 mm²).

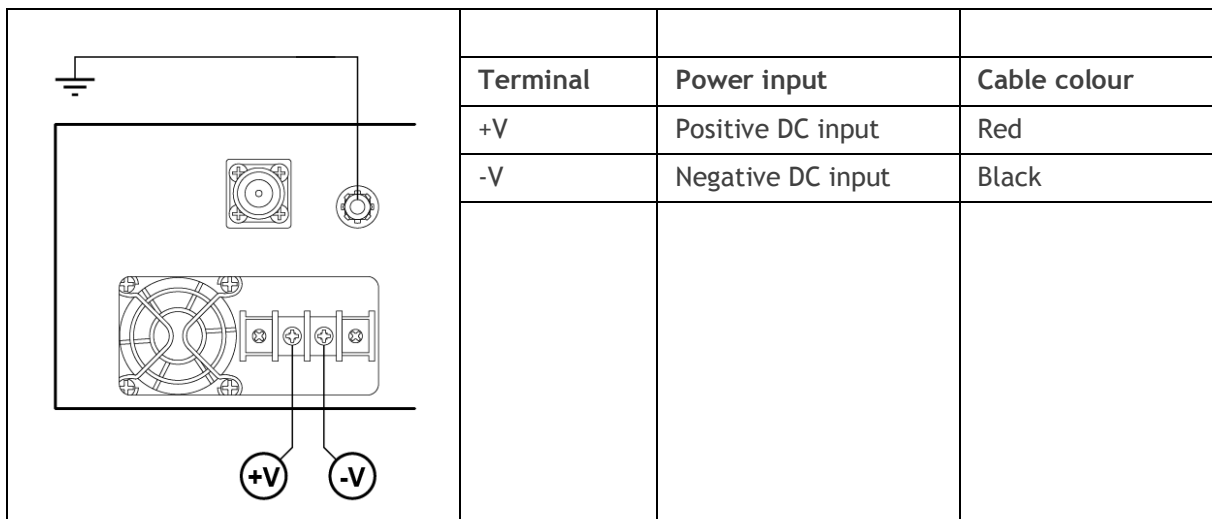

12 VDC Cable

The 12 VDC power supply is supplied with a 3 metre red/black cable of two pairs of 2.3 mm² (72 strands of 0.2 mm²) making a total of 4.6 mm² per connection. This increase in wire size is to carry the increased current consumption of the 12 VDC supply (max 18 Amps per terminal).

This 3 metre cable is engineered to power a fully loaded terminal from a 12 VDC supply. A longer cable should not be used as the additional voltage drop could cause the power supply to fail.

If longer cable runs are required between the 12 VDC power supply and the terminal, it is suggested that high current distribution bus bars are used to feed the rack and the supplied power cable used between the bus bars and the terminals.

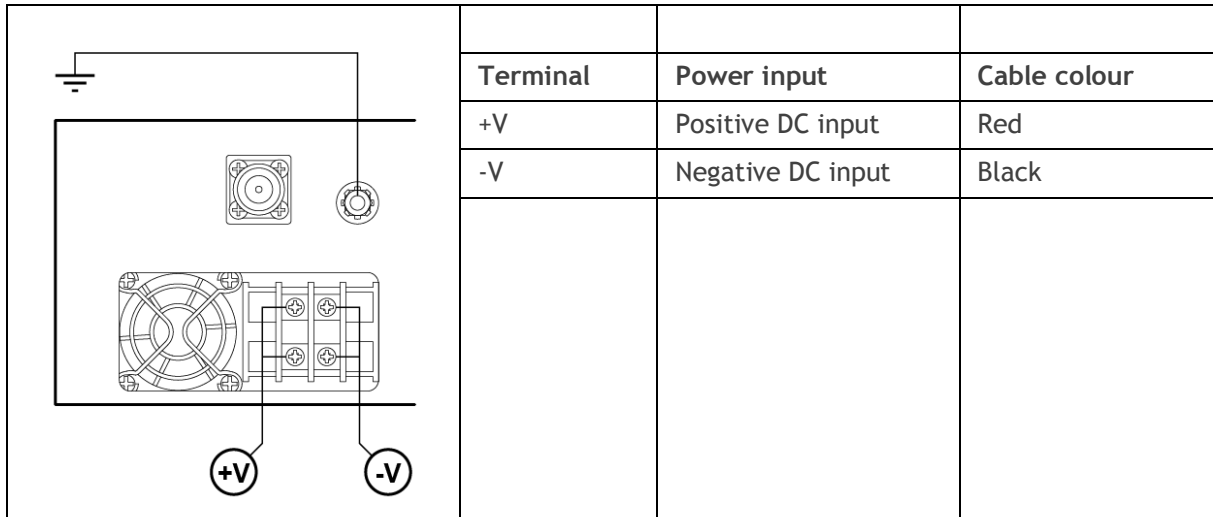

1. Fit both pairs of lugs into the terminal screw clamps.
2. Twist the other ends together when fitting to the source.

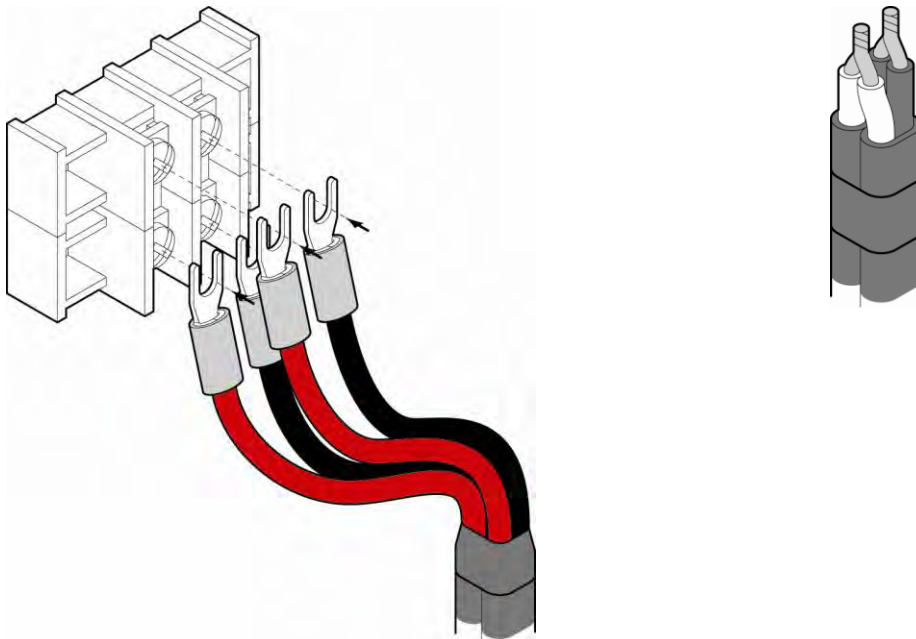

AC Power Supply

There is one AC power supply for the terminal. This AC power supply is auto-sensing to operate with a nominal input voltage of 115 Vrms or 230 Vrms.

The power input is terminated on the front panel of the terminal using a standard IEC plug. This power supply has a power on/off switch.

A power cable is included in the accessory kit and is pre-fitted with an IEC socket connector and the country-specific plug that was specified when the order was placed.

Nominal voltage	Input voltage range	Maximum Power input	Max VA	Frequency
115 VAC	103 - 127 Vrms	180 W	400 VA	47 - 63 Hz
230 VAC	207 - 254 Vrms	180 W	400 VA	47 - 63 Hz

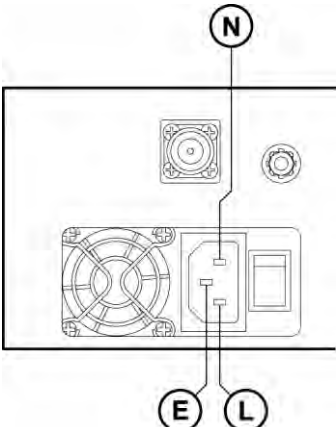
			
	Terminal	Power input	Cable colour
	E	Earth	Green/yellow
	N	Neutral	Blue
L	Line / Phase	Brown	

Important: Please check with your local power authority about correct colour usage and pinouts. AC power cords used must be in accordance with national requirements.

Norway and Sweden: PLUGGABLE CLASS I EQUIPMENT intended for connection to a telephone network or similar communications system requires a label stating that the equipment must be connected to an earthed mains socket outlet.

Brownout Recovery Module

A Brownout Recovery Module (BRM) is factory fitted to the Aprisa XE motherboard power connector when the radio is fitted with an AC power supply.

The AC power supply has a safety mechanism that trips the power if it detects a power input brownout. The BRM restarts the power supply after 3 seconds.

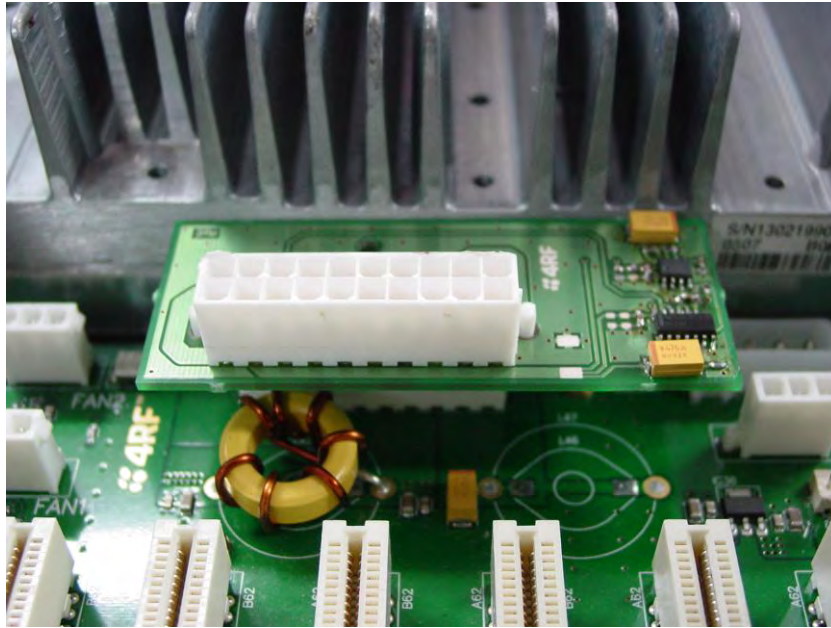

Safety Earth

The terminal chassis must have a protection / safety earth connected between the terminal earth stud and a common protection earth in the rack. The DC power input can be either positive grounded or negative grounded depending on the power supply system available.

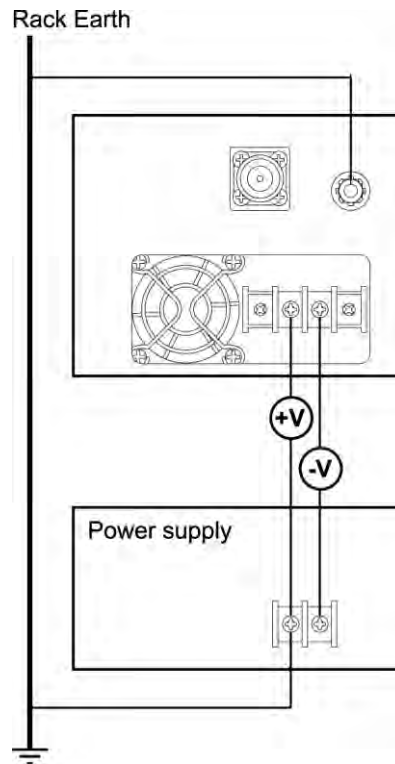

Ground the terminal chassis using the terminal earth stud on the front panel as shown:

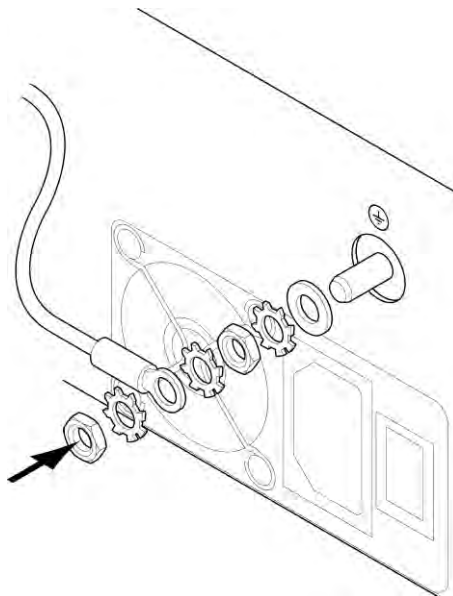

Bench Setup

Before installing the link in the field, it is recommended that you bench-test the link. A suggested setup for basic bench testing is shown below:

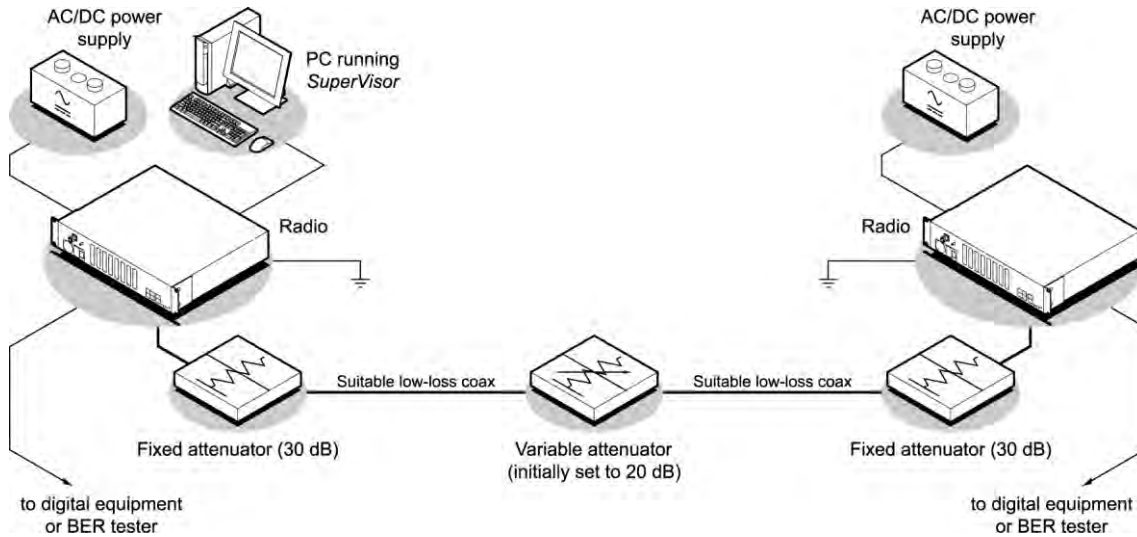

When setting up the equipment for bench testing, note the following:

- Earthing—the terminal should be earthed at all times. The terminal earth stud must be connected to a protection earth.
- Attenuators— In a bench setup, there must be 60 - 80 dB at up to 3 GHz of 50 ohm coaxial attenuation (capable of handling the transmit power of +35dBm) between the terminals' N type antenna connectors.

This can be achieved with two fixed attenuators fitted to the antennas 'N' connectors and a variable attenuator with a ≥ 60 dB range. You can use other attenuator values as long as you consider the transmit power output level (max +33 dBm) and the receiver signal input (max -20 dBm).

- Cables—use double-screened coaxial cable that is suitable for use up to 3 GHz at ≈ 1 metre.

CAUTION: Do not apply signals greater than -20 dBm to the antenna connection as they can damage the receiver.

6. Connecting to the Terminal

Connecting to the Terminal's Setup Port

You can configure basic terminal settings by connecting to the terminal using the Setup cable. This can be useful if you need to confirm the terminal's IP address, for example.

You can password-protect the setup menu to prevent unauthorized users from modifying terminal settings.

A straight RJ-45 connection cable and a RJ-45 to DB-9 adaptor is provided with each terminal.

1. Plug the DB-9 into serial port of the PC.
2. Plug the RJ-45 connection cable into the adaptor as shown below:

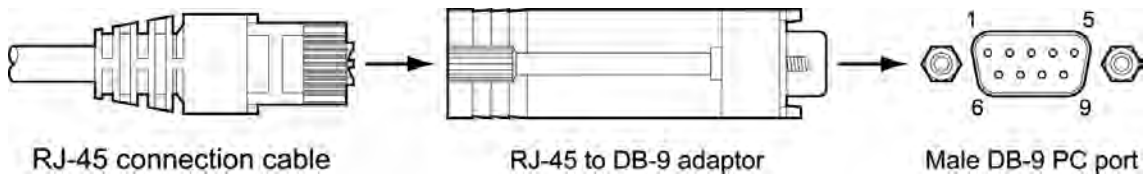

3. Plug the other end of the RJ-45 connection cable into the SETUP port of the terminal.

Note: Connecting the PC serial port to the Interface Cards or ALARM connectors may result in damage to the PC or terminal.

Ensure that the RJ-45 connection cable is connected to the RJ-45 connector marked 'SETUP'.

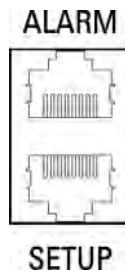

Cable pinouts (RJ-45 to DB-9)

If you need a conversion connector or cable, refer to the following table:

Console port (DCE, RJ-45)	RJ-45 to RJ-45 cable		RJ-45 to DB-9 adaptor		PC port (DTE, DB-9)	
	Signal	RJ-45 pin	RJ-45 pin	RJ-45 pin		DB-9 pin
RTS		1	1	1	7	RTS
DTR		2	2	2	4	DTR
TXD		3	3	3	3	TXD
GND		4	4	4	5	GND
GND		5	5	5	NC	NC
RXD		6	6	6	2	RXD
DSR		7	7	7	6	DSR
CTS		8	8	8	8	CTS

Configure the PC COM Port Settings

Terminal emulation software e.g. HyperTerminal is used to setup the basic configuration of a terminal.

The PC's COM port settings must be setup as follows:

Bits per second	115200
Data bits	8
Parity	None
Stop bits	1
Flow Control	None

Start a HyperTerminal Session

1. On the PC, select Start > Programs > Accessories > Communications > HyperTerminal.
2. Enter a name for the connection and click OK.

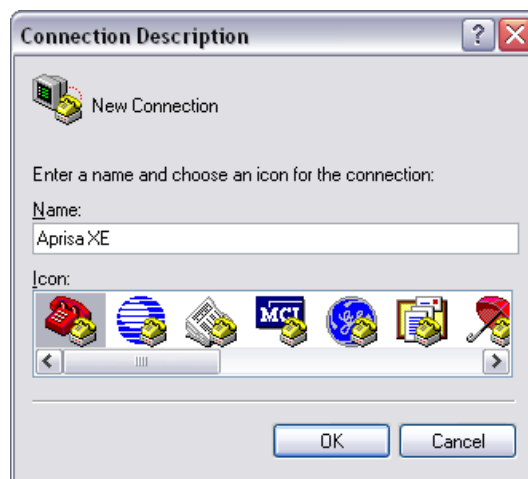

3. Select the designated COM Port from the Connect Using drop-down box. Ensure it is the same COM port that you configured earlier on your PC. Click OK.

Note: The Country/region, Area code, and Phone number information will appear automatically.



- Set the COM Port settings as follows:

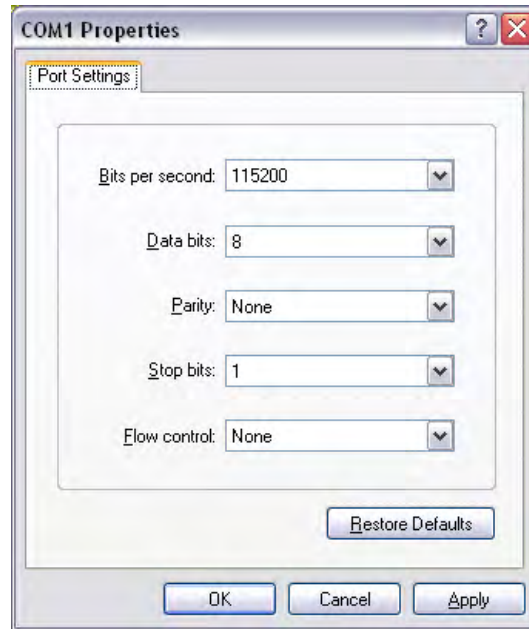

- When you have completed the settings, click OK, which will open the HyperTerminal window.
- Apply power to the terminal.

Note: If power was applied to the terminal before launching HyperTerminal, hit the Enter key to initiate the link.

When the terminal has completed startup, you will be presented with the Setup menu:

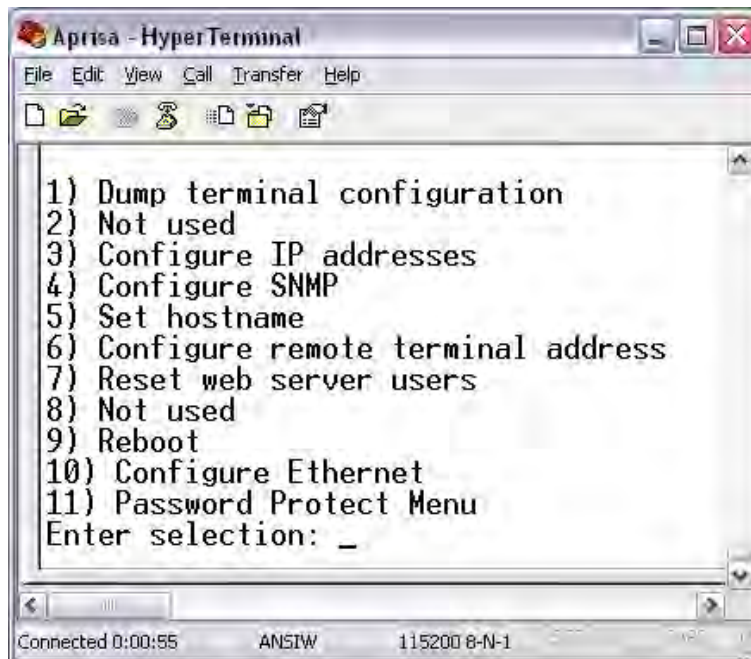

Connecting to the Terminal's Ethernet Interface

The main access to a terminal for management is with the ethernet interface using standard IP networking. There should be only one ethernet connection from the terminal to the management network.

The terminals are pre-configured to use IP addressing in one of the common 'non-routable' IP address ranges. This means the terminals are usually recognized by your operating system without any reconfiguration.

However, you should change these default addresses (see 'Changing the Terminal's IP Address' on page 64) to comply with your IP addressing scheme.

In the example below, the active management PC must only have one connection to the link as shown by path ①. There should not be any alternate path that the active management PC can use via an alternate router or alternate LAN that would allow the management traffic to be looped as shown by path ②.

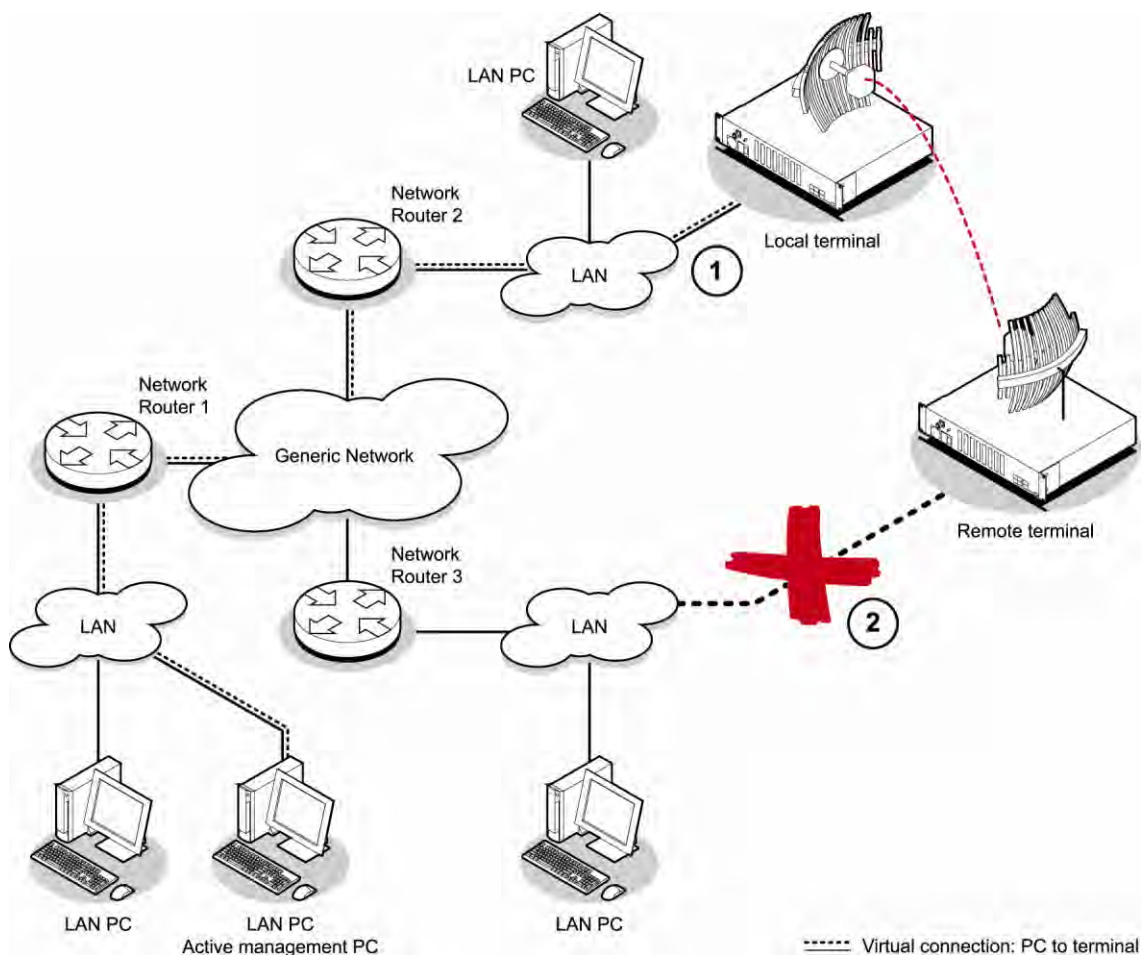

PC Requirements for SuperVisor

SuperVisor requires the following minimum PC requirements:

- Microsoft Windows 2000, NT, XP, Vista or Windows 7
- Personal computer with 1.6 GHz Pentium IV
- 512 MB of RAM
- 200 MB of free hard disk space
- Ethernet interface (Local Area Network)
- COM port
- Web browser with a Java plug-in such as Mozilla FireFox (recommended), Microsoft Internet Explorer 5.0, or Netscape Navigator 6.0, but SuperVisor also supports other major web browsers.
- Java JRE 1.6.

Note: Mozilla Firefox, Internet Explorer and the Java JRE are provided on the Aprisa CD (see 'Aprisa XE CD Contents' on page 20).

PC Settings for SuperVisor

To change the PC IP address:

If your PC has previously been used for other applications, you may need to change the IP address and the subnet mask settings. You will require Administrator rights on your PC to change these.

Windows XP example: Configure IP settings

1. Open the 'Control Panel'.
2. Open 'Network Connections' and right click on the 'Local Area Connection' and select 'Properties'.
3. Click on the 'General' tab.
4. Click on 'Internet Protocol (TCP/IP)' and click on properties.
5. Enter the IP address and the subnet mask (example as shown).
6. Click 'OK' then close the Control Panel.

If the terminal is on a different subnet from the network the PC is on, set the PC default gateway address to the network gateway address which is the address of the router used to connect the subnets (for details, consult your network administrator).

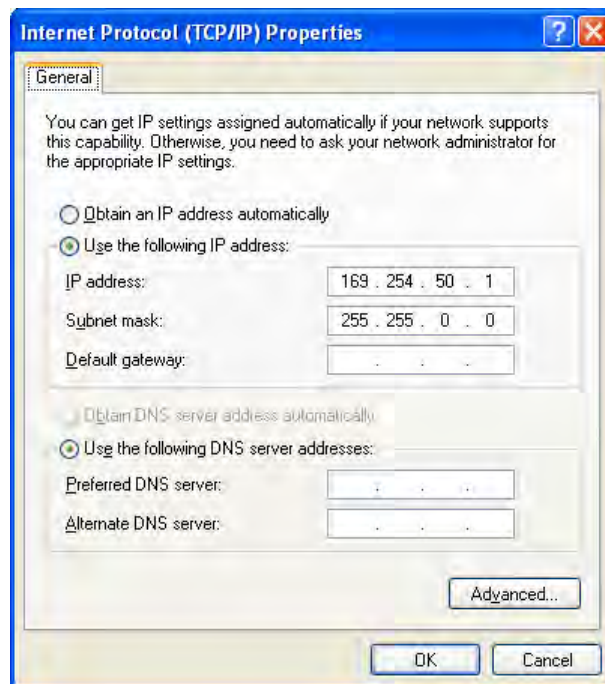

To change the PC connection type:

If your PC has previously been used with Dial-up connections, you may need to change your PC Internet Connection setting to 'Never dial a connection'.

Windows XP example: Configure Windows to Never Dial a Connection

1. Open the 'Control Panel'.
2. Open 'Internet Options' and click on the 'Connections' tab.
3. Click the 'Never dial a connection' option.
4. Click 'OK' then close the Control Panel.

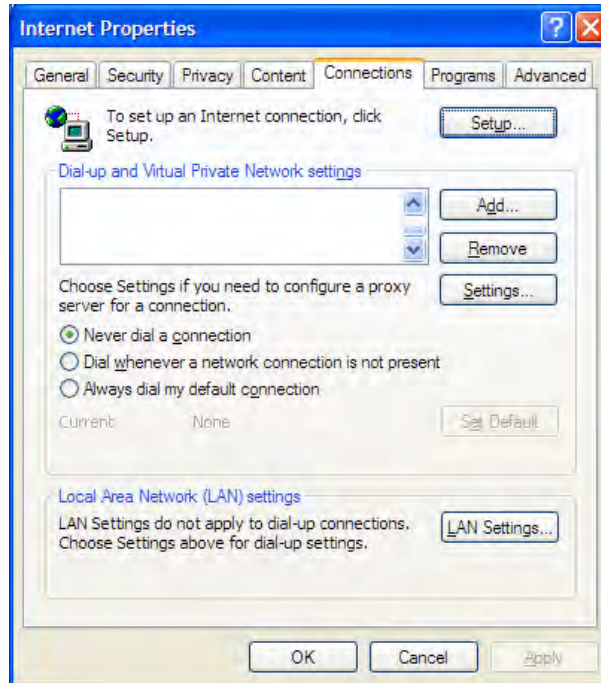

To change the PC pop-up status:

Some functions within SuperVisor require Pop-ups enabled e.g. saving a MIB

Windows XP example: Configure explorer to enable Pop-ups

1. Open the 'Control Panel'.
2. Open 'Internet Options' and click on the 'Privacy' tab.
3. Click on 'Settings'.
4. Set the 'Address of Web site to allow' to the terminal address or set the 'Filter Level' to 'Low: Allow Pop-ups from secure sites' and close the window.
5. Click 'OK' then close the Control Panel.



IP Addressing of Terminals

When logging into a link, it is important to understand the relationship between the Local / Remote and the Near end / Far end terminals.

The **Near** end terminal is the terminal that has its ethernet port physically connected to your IP network.

The **Far** end terminal is the terminal that is at the other end of the link from the Near end terminal and communicates through the management connection over the radio link to the Near end terminal.

The **Local** terminal is the terminal that SuperVisor is logged into and is displayed on the left hand side of the SuperVisor screen. The Local terminal can be the Near end or Far end terminal.

The **Remote** terminal is the terminal that is at the other end of the link from the Local terminal and is displayed on the right hand side of the SuperVisor screen.

To prevent confusion when operating SuperVisor, determine the IP address of the Near end terminal and log into that terminal. This is now the Local terminal.

The distinction is important as:

- Some functions can only be carried out on the Local terminal.
- Having different configurations at each end of the link will disrupt communications between the terminals. In these circumstances it is important to make changes to the Far end terminal of the link first. The link is then lost only until the near end configuration is completed and communication restored.

If the Near end terminal is modified first, the link is lost for much longer as staff will have to either physically visit the Far end terminal to restore the link, or restore the near end to match the far end, re-establish the link, then start the process again, this time with the Far end terminal first.

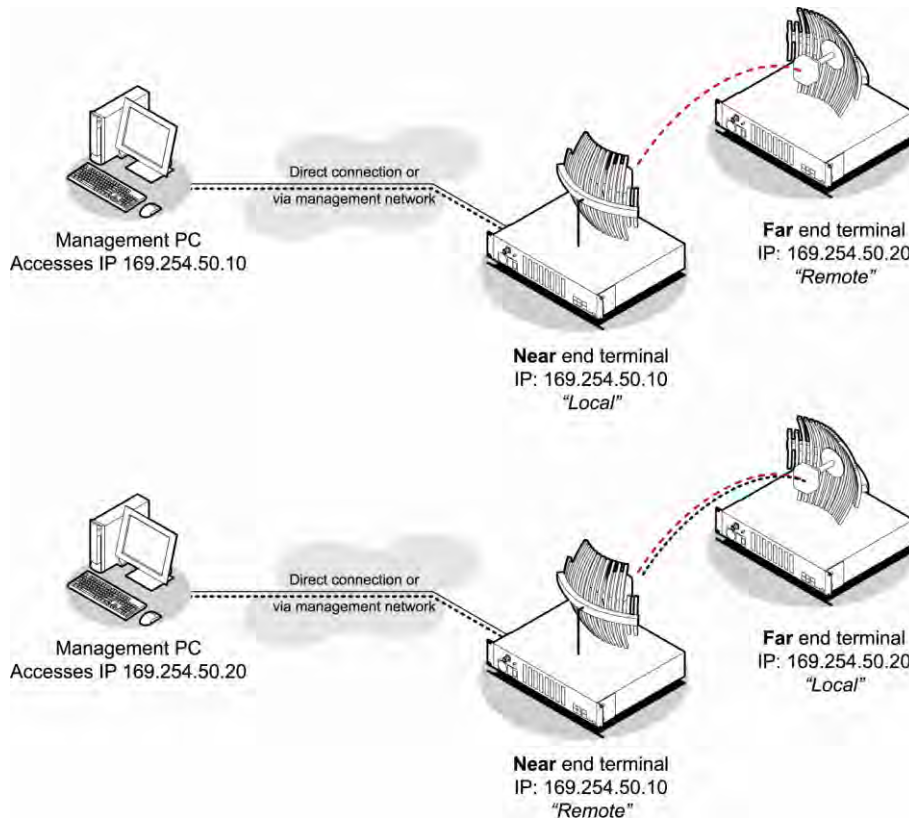

Network IP Addressing

Same Subnet as the Local PC

The following diagram shows a link interconnected on the same subnet as the local PC terminal used for configuration.

In this example, the local PC, as well as the local and remote terminals, are on the same subnet and therefore have the same subnet mask 255.255.255.0.

This will allow the PC and the terminals to communicate with each other.

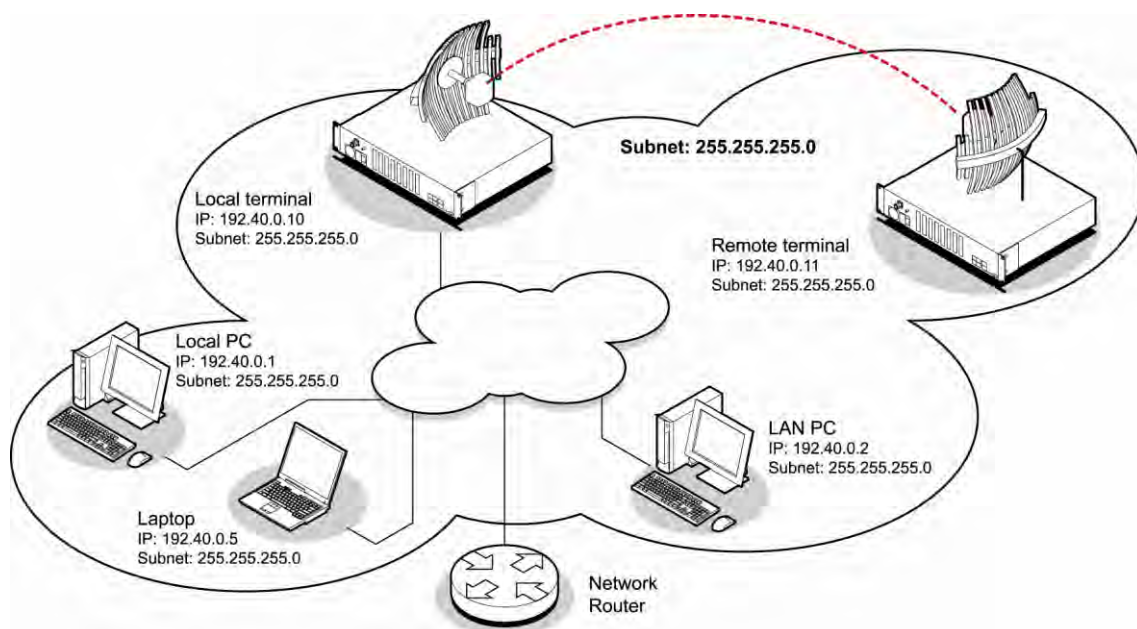

Different Subnet as the Local PC

The following diagram shows a link interconnected on a different subnet as the local PC used for configuration, and communicating through a network. This can be achieved on the condition that network router(s) 1 and 2 are programmed to recognize each other and the various subnets on the overall network.

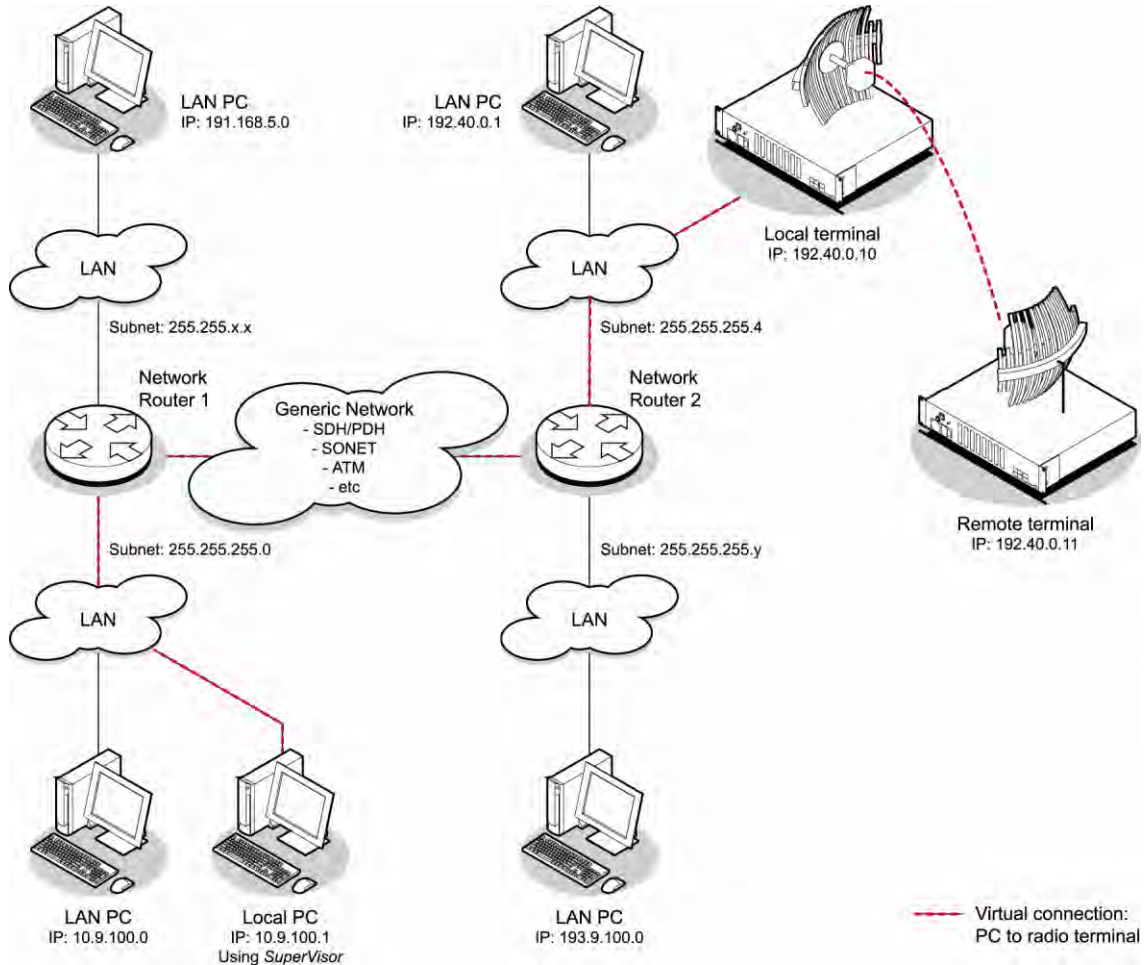

7. Managing the Terminal

The command line setup menu can be used to:

- Provide basic access to the terminal to set IP addresses
- Check or set basic settings of the terminal

4RF SuperVisor is an embedded element manager for the Aprisa XE terminal which is used to:

- Configure radio and interface parameters
- Setup cross connections between traffic interfaces
- Monitor performance, terminal status and alarm details

The Setup Menu

1. Initiate the link by either applying power to the terminals or, if the terminals are already powered up, pressing the Enter key.
2. At the prompt, enter your selection:

Selection		Explanation
1)	Dump terminal configuration	This shows basic terminal data such as Terminal ID, IP data and radio parameters of TX and RX frequency, TX power, modulation type and channel size.
2)	Not used	
3)	Configure IP addresses	Use this if you want to set the IP address, subnet mask or gateway address of the local terminal.
4)	Configure SNMP	Use to display SNMP settings, setup the SNMP Access Controls and Trap Destinations and reset SNMP settings to defaults.
5)	Set hostname	Use this to set a name that can be used in conjunction with DNS.
6)	Configure remote terminal address	Use this to set the IP address of the remote terminal.
7)	Reset web server users	Deletes all existing usernames and passwords in the 'User Table' and restores default usernames and passwords.
8)	Not used	
9)	Reboot	Reboots the terminal.
10)	Configure Ethernet	Use this to display the Ethernet configuration and reset the Ethernet settings to the defaults.
11)	Password Protect Menu	Use this to password-protect the menu to prevent unauthorized users from modifying terminal settings. The password is setupxe.

To Get or Set the IP Address of a Terminal Using Setup

To get the IP address of a terminal using setup:

1. At the prompt, type 1 and enter.

The following information appears:

- the IP addresses of the local and remote terminals
- the subnet mask and gateway of the local terminal
- the TFTP of the remote terminal

To set the IP address of a terminal using setup:

1. At the prompt, enter 1.
2. Enter 3 to configure the local terminal IP address.

Set the following for the terminal using the standard format xxx.xxx.xxx.xxx:

- 1) IP address
- 2) Subnet mask
- 3) Gateway address

3. Enter 4 (Quit) to return to the main menu.
4. Enter 6 to configure the remote terminal IP address.

Important: You must ensure that the IP addresses of the local and remote terminals are on the same subnet as the PC being used to configure the terminals.

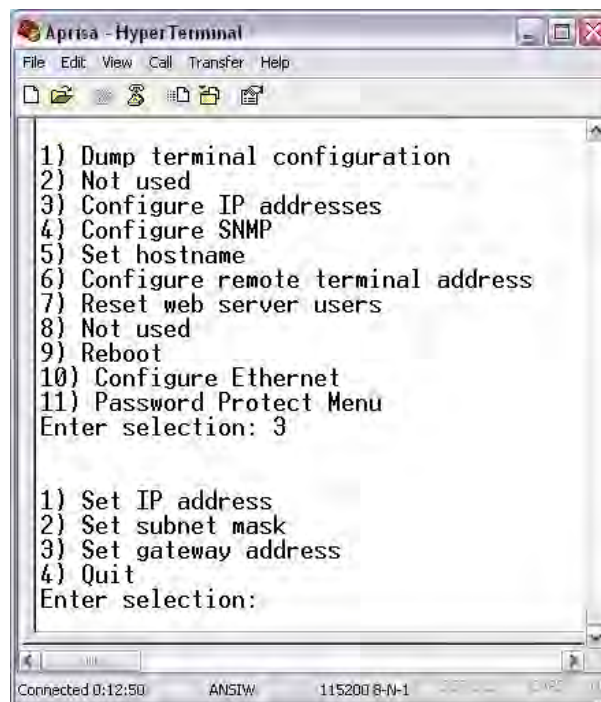

5. Enter 4 (Quit) to return to the main menu.
6. Enter 9 (Are you sure y/n) to reboot the terminal.

SuperVisor

The SuperVisor management software is pre-loaded into an integrated web-server within the terminal. SuperVisor runs on any Java-enabled web browser.

You can use SuperVisor to:

- display and configure terminal parameters
- view the terminal alarms
- monitor the performance and status of the link
- upgrade the terminal software
- save and load configuration files
- save performance and error information to a log file



4RF SUPERVISOR™ **Aprisa XE**

Login Cookies must be enabled

User Name

Password

Use Popup Window

Local Terminal OK RX TX

Terminal ID	Local
Location	Wellington NZ
Contact Details	www.4RF.com
RX Frequency (MHz)	1474
RSSI (dBm)	-52.7
SNR (dB)	35.24
TX Frequency (MHz)	1425
TX Power (dBm)	28

goahead
WEBSERVER

SuperVisor Logging In

The maximum number of concurrent users that can be logged into a terminal is 5.

If SuperVisor is inactive for a period of 30 minutes, the terminal will automatically log out the user.

To log in to SuperVisor:

1. Open your web browser and enter the IP address of the terminal.

Note: If you haven't yet assigned IP addresses to the terminals, use the factory-configured IP addresses (see 'Changing the Terminal's IP Address' on page 64).

If you don't know the IP address of the terminal, you can determine it using terminal emulation software (see 'To Get or Set the IP Address of a Terminal Using Setup' on page 58).

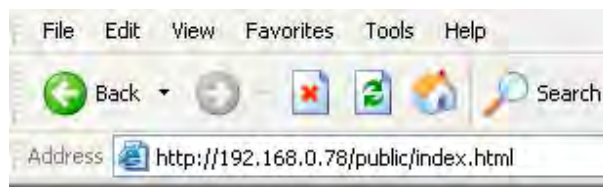

2. Login with the user name and password assigned to you.

Note: If unique user names and passwords have not yet been configured, use the default user names and passwords (see 'Setting up users' on page 65).

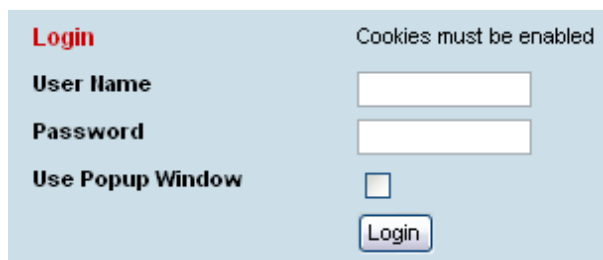

Important: After you login for the very first time, it is recommended that you change the default admin password for security reasons (see 'Changing passwords' on page 67).

3. Tick the 'Use Popup Window' tick box if you want a separate browser window to launch after you have logged in. The login page remains open in one window allowing you to view or configure settings in another page. This is useful if you have more than one link to configure, for example, protected terminals.
4. When you have logged in, the Summary page shows a summary of both the Local and Remote terminals' parameters.

SuperVisor Logging Out

As the maximum number of concurrent users that can be logged into a terminal is 5, not logging out correctly can restrict access to the terminal until the after the timeout period (30 minutes).

Logging out from a terminal will logout all users logged in with the same user name.

If the SuperVisor window is closed without logging out, the terminal will automatically log the user out after a timeout period of 30 minutes.

To log out of SuperVisor:

1. Click on the 'Logout' button on the Summary Bar.

SuperVisor Main Screen

The SuperVisor Main Screen presents a summary of both the local and remote terminals and the status of the terminal front panel LED indicators:

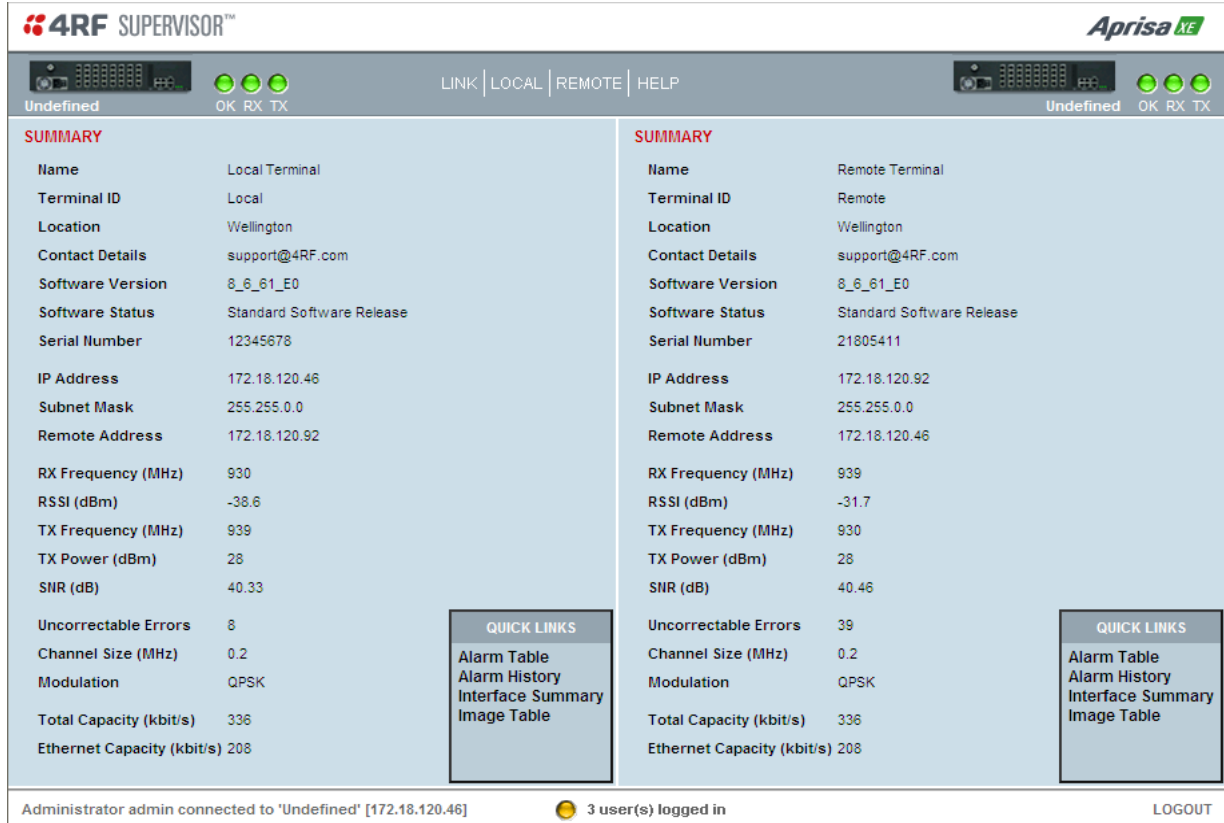

The screenshot displays the SuperVisor Main Screen for the Aprisa XE terminal. The interface is split into two columns, each showing a summary of terminal information for a 'Local Terminal' and a 'Remote Terminal'. The status of the terminal front panel LED indicators (OK, RX, TX) is shown at the top of each column.

Local Terminal	Remote Terminal
Name: Local Terminal	Name: Remote Terminal
Terminal ID: Local	Terminal ID: Remote
Location: Wellington	Location: Wellington
Contact Details: support@4RF.com	Contact Details: support@4RF.com
Software Version: 8_6_61_E0	Software Version: 8_6_61_E0
Software Status: Standard Software Release	Software Status: Standard Software Release
Serial Number: 12345678	Serial Number: 21805411
IP Address: 172.18.120.46	IP Address: 172.18.120.92
Subnet Mask: 255.255.0.0	Subnet Mask: 255.255.0.0
Remote Address: 172.18.120.92	Remote Address: 172.18.120.46
RX Frequency (MHz): 930	RX Frequency (MHz): 939
RSSI (dBm): -38.6	RSSI (dBm): -31.7
TX Frequency (MHz): 939	TX Frequency (MHz): 930
TX Power (dBm): 28	TX Power (dBm): 28
SNR (dB): 40.33	SNR (dB): 40.46
Uncorrectable Errors: 8	Uncorrectable Errors: 39
Channel Size (MHz): 0.2	Channel Size (MHz): 0.2
Modulation: QPSK	Modulation: QPSK
Total Capacity (kbit/s): 336	Total Capacity (kbit/s): 336
Ethernet Capacity (kbit/s): 208	Ethernet Capacity (kbit/s): 208

QUICK LINKS (available for both terminals):

- Alarm Table
- Alarm History
- Interface Summary
- Image Table

Administrator admin connected to 'Undefined' [172.18.120.46] 3 user(s) logged in LOGOUT

SuperVisor Menu Bar

The SuperVisor Menu Bar at the top of the screen shows the names of the terminals, the top level menus and three status indicators for both the local and remote terminals. These indicators reflect the status LED indicators on the front panel of terminal.



There are four menus available:

- Link - menu options for both terminals in a link
- Local - menu options for the local terminal in a link
- Remote - menu options for the remote terminal in a link
- Help - provides details about the terminal

SuperVisor Summary Bar



The SuperVisor Summary Bar at the bottom of the screen shows:

- The login name of the person currently logged in together with the name of the local terminal and its IP address.
- A login alarm that indicating that someone else has logged into and could be working on the same link. The LED is green for 1 user and yellow for more than 1 user.
- The number of users logged in to the link
- A SuperVisor logout button

Changing the Terminal's IP Address

You can use SuperVisor to change the IP address of the terminal from the default. Alternatively, you can assign the IP address using the SETUP port (see 'To Get or Set the IP Address of a Terminal Using Setup' on page 58).

To change the IP address of the terminals using SuperVisor:

1. Launch your web browser and connect to the terminal using the one of the factory-configured default IP addresses shown below:

	Terminal	IP address
Unprotected terminals	Terminal 1 (local)	169.254.50.10
	Terminal 2 (remote)	169.254.50.20
Protected terminals	Terminal 1, terminal A (local)	169.254.50.10
	Terminal 1, terminal B (local)	169.254.50.11
	Terminal 2, terminal A (remote)	169.254.50.20
	Terminal 2, terminal B (remote)	169.254.50.21

Note: The factory default settings for the subnets is 255.255.0.0; the gateway is 0.0.0.0.

2. Log into the terminal as the administrator with the user name 'admin' and the password 'admin'.

Note: For security reasons, change the admin password (see 'Changing passwords' on page 67) as soon as possible.

3. Select Link or Local or Remote > Terminal > Advanced and make the necessary changes.

Note: If this IP address change is being made over the RF link, it is important to change the far end of the link first.

4. Once you have changed the IP address of a terminal, you must perform a hard reboot of the terminal and then reconnect to it using the new IP address.

Setting Up Users

Note: You must login with 'admin' privileges to add, disable, delete a user or change a password.

User groups

There are three pre-defined user groups to allocate access rights to users. These user groups have associated default user names and passwords of the same name.

User Group	Default User Name	Default Password	Access Rights
View	view	view	Users in this group can only view terminal parameters.
Modify	modify	modify	Users in this group can view and edit terminal parameters.
Admin	admin	admin	Users in this group have full access to all terminal parameters including the ability to add and change users.

Adding a User

1. Select Local or Remote > Maintenance > User Admin > User Table.
2. Select an empty line (that isn't allocated to an existing user) and then click Edit.

9	View	no	<input checked="" type="radio"/>
10	View	no	<input type="radio"/>

3. Enter the user name.

A user name can be up to 32 characters but cannot contain back slashes, forward slashes, spaces, tabs, single or double quotes.

4. Enter the Password and the Confirm Password.

A password can be up to 32 characters but cannot contain back slashes, forward slashes, spaces, tabs, single or double quotes.

5. Select the group that they will belong to (View, Modify, or Admin).
6. If the user requires immediate access, enable the user by clicking on Yes.

USER DETAILS

Name

Password

Confirm Password

Group

Enabled no yes

7. Click Apply.

Note 1: The new user must be setup on both the Local and Remote terminals.

Note 2: For the changes to take effect, you must reboot the terminal (Local > Maintenance > Reboot).

Disabling a User

1. Select Local or Remote > Maintenance > User Admin > User Table.
2. Select the user who you want to disable.
3. Click Edit to display the User details and set Enabled to 'No'.
4. When you have made your changes, click Apply to apply changes or Reset to restore the previous configuration.

Note: For the changes to take effect, you must reboot the terminal (Local > Maintenance > Reboot).

Deleting a User

1. Select Local or Remote > Maintenance > User Admin > User Table.
2. Select the user you want to delete.
3. Click Edit to display the user details and delete the User Name and Password.
4. Reset the Group to 'View' and set Enabled to 'no'.
5. When you have made your changes, click Apply to apply changes or Reset to restore the previous configuration.

Note: For the changes to take effect, you must reboot the terminal (Local > Maintenance > Reboot).

Saving User Information

You can save the list of users to your PC and then load this file to another terminal. This is useful if you have multiple terminals to configure.

To save the user table to file:

1. Select Local > Maintenance > User Admin > Save User List.
2. Select the 'Save to disk' option in the dialog box that appears.
3. In the next dialog box that appears, navigate to the directory where you want to save the file, enter a suitable filename, and then click Save (The default name for this file is 'downloadUsers').

Note: If this dialog box does not appear, change your Internet security settings to allow downloads. You may also need to check your file download location setting.

To save the file to another terminal:

1. Select Local > Maintenance > User Admin > Load User List.
2. On the Upload Users page, select Browse and navigate to the file on your PC.
3. Click Apply.

The User Table appears and you can edit users, as required.

Changing Passwords

1. Select Local or Remote > Maintenance > User Admin > User Table.

USER TABLE				
Index	Name	Group	Enabled	Select
1	view	View	yes	<input checked="" type="radio"/>
2	modify	Modify	yes	<input type="radio"/>
3	admin	Admin	yes	<input type="radio"/>
4		View	no	<input type="radio"/>
5		View	no	<input type="radio"/>
6		View	no	<input type="radio"/>
7		View	no	<input type="radio"/>
8		View	no	<input type="radio"/>
9		View	no	<input type="radio"/>
10		View	no	<input type="radio"/>

[Edit...](#)

2. Select the user whose password you want to change and click Edit.
3. Enter the new Password and the new Confirm Password.

A password can be up to 32 characters but cannot contain back slashes, forward slashes, spaces, tabs, single or double quotes.

4. When you have made your changes, click Apply.

Viewing User Session Details

Administrators can check who is currently logged in, the computer they are logging in from, and how long they have been logged in for.

Note: A 'session' is the period of time that begins when someone logs into the terminal and ends when they logout.

To view user session details:

1. Select Local > Maintenance > User Admin > Session Details.

SESSION DETAILS			
User Name	Time (mins)	Last Access (mins)	Address
Tracy	1	0	192.168.0.104
Andrew	2	0	192.168.0.35
JohnSmith	2	0	192.168.0.104

The 'Session Details' shows a list of the current users:

- User Name: the User Name logged into the terminal.
- Time: the number of minutes the user has been logged in.
- Last Access: the number of minutes the user last accessed the terminal in this session.
- Address: the address of the computer or proxy server address logged into the terminal.

8. Configuring the Terminal

Configuring the RF Settings

The RF settings are factory-configured before dispatch to the customer requirements. However, you can change the RF settings, if required.

If two fundamental radio parameters (RX and TX frequency or modulation) are changed on the remote terminal in the same apply action (simultaneously), the first parameter change could break the communications link to the remote terminal and prevent the other commands from being actioned. There is a two second delay between receiving the command and actioning it to allow for subsequent commands to be received before the communications link is lost.

To configure RF settings:

Select Link or Local or Remote > Terminal > Basic:

BASIC TERMINAL SETTINGS

RX Frequency (MHz)	<input type="text" value="1474"/>
TX Frequency (MHz)	<input type="text" value="1425"/>
TX Power (dBm)	<input type="text" value="28"/> ▼
Channel Size (MHz)	<input type="text" value="1.75"/>
Modulation	<input type="text" value="64 QAM"/> ▼
Interleaver State	Enabled
Name	<input type="text" value="Local Terminal"/>
Terminal ID	<input type="text" value="Local"/>
Location	<input type="text" value="Wellington"/>
Contact Details	<input type="text" value="www.4RF.com"/>

Note: Transmit frequency, transmit power, channel size, modulation and antenna polarization would normally be defined by a local regulatory body and licensed to a particular user.

Refer to your site license details when setting these fields.

RX and TX Frequency

The local terminal transmit frequency must match the receive frequency of the remote terminal and the remote terminal transmit frequency must match the receive frequency of the local terminal.

When setting the RX and TX frequency with SuperVisor, the frequency entered is automatically resolved to the synthesizer step size for the terminal frequency band e.g. an ETSI 1400 MHz band frequency entry of 1474,010,000 Hz will be changed to 1474,012,500 Hz (see synthesizer step size in the table 'Frequency Bands' on page 287).

The RX and TX frequency entered must be:

- Within the frequency band limits of the chosen RF frequency band of the terminal as specified in 'Frequency Bands' on page 287. e.g. for an ETSI frequency band of 1400 MHz, the frequency band limits are 1350 to 1550 MHz.
- Within the TX / RX passband of the duplexer fitted in the terminal e.g. for a frequency band of 1400 MHz, the standard duplexer passband is 7 MHz and the TX / RX split is ≥ 48 MHz (see Duplexer (bandpass) 'Duplexers' on page 301).

The duplexer passband and center frequencies are written on the duplexer label.

The TX and RX frequencies are validated against the duplexer parameters entered on SuperVisor Link or Local or Remote > Terminal > Duplexer (see 'Setting the Duplexer Parameters' on page 79).

If the TX or RX frequency entered is not valid i.e. outside the operating range of the duplexer, a warning message will popup. OK accepts the frequency entered and cancel rejects the frequency entered.

Important: Changing the remote terminal RX or TX frequency will disable all management communication to the remote terminal but by changing the local terminal to match the remote terminal, the radio link will be restored as will the management communication

BUT if the remote terminal RX or TX frequency is changed to be outside the operating range of the terminal, changing the local terminal to match the remote terminal will not restore the radio link and all management communication will be lost.

The remote terminal TX and RX frequencies cannot be changed simultaneously i.e. change one direction and 'Apply' the change and then change the other direction and 'Apply' the change.

To change both TX and RX frequencies:

1. Change the remote terminal RX frequency and 'Apply' the change. The radio link will fail.
2. Change the local terminal TX frequency to that of the remote RX frequency and 'Apply' the change. The radio link will restore.
3. Change the remote terminal TX frequency and 'Apply' the change. The radio link will fail.
4. Change the local terminal RX frequency to that of the remote TX frequency and 'Apply' the change. The radio link will restore.

Transmit power

The transmitter power is the power measured at the duplexer output port.

The transmitter power adjustment range varies depending on the Modulation type and frequency band of the terminal. For ETSI transmitter power range see 'Transmitter Power ETSI' on page 290.

Channel size

The RF channel size is a factory-configured setting determined by the Aprisa XE hardware option.

Modulation

Both terminals must be set to the same modulation type.

When you change the modulation type in an operational terminal, traffic across the link will be interrupted and you may need to change the cross connections capacity, as the Total Capacity of the radio link may be exceeded.

Interleaver state

This Interleaver State displays the current state of the modem interleaver.

Interleaver State	Modem Interleaver Operation
Default	The modem interleaver is on for channel sizes of 250 kHz and greater and off for channel sizes of 200 kHz and less.
Enabled	The modem interleaver is on.
Disabled	The modem interleaver is off.

Modem Performance Settings

To view or change the modem performance settings:

Select Link or Local or Remote > Terminal > Modem

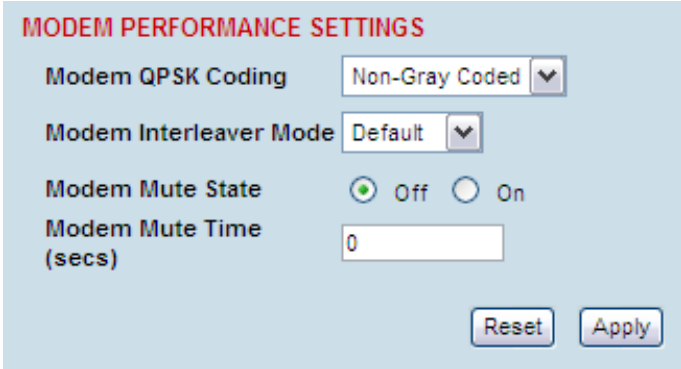

MODEM PERFORMANCE SETTINGS

Modem QPSK Coding: Non-Gray Coded

Modem Interleaver Mode: Default

Modem Mute State: Off On

Modem Mute Time (secs): 0

Reset Apply

Modem QPSK Coding

When the Modulation type is set to QPSK, the default QPSK Coding setting is ‘Non-Gray Coded’ but the QPSK Coding can use ‘Gray Coded’ for interoperability with older hardware.

Modem Interleaver Mode

The Modem Interleaver improves modem bit error rate but increases the end to end link delay so the Modem Interleaver should be enabled where a low bit error rate is required and disabled where a low end to end link delay is required.

The ‘Default’ Modem Interleaver Mode setting is on for channel sizes of 250 kHz and greater and off for channel sizes of 200 kHz and less. The specification of end to end link delay for both interleaver on and off is given in the relevant RF Specification section. For ETSI Link Delays, see ‘Link Delays ETSI’ on page 292.

When you change the Modem Interleaver Mode in an operational terminal, traffic across the link will be interrupted.

Both terminals must be set to the same Modem Interleaver Mode.

Modem Mute Mode

The Aprisa XE radio always mutes its interface ports when the modem loses lock.

The Modem Mute feature mutes its interface ports when the modem Reed Solomon forward error correction capability can no longer correct errors.

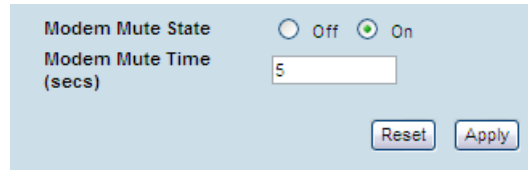

Modem Mute State Off On
Modem Mute Time (secs)
Reset Apply

This can occur when the signal strength of the RF link reduces to within about 2 dB of the theoretical sensitivity of the radio or when the radio is operating well above the sensitivity threshold but is in an environment subject to impulse noise interference on the RF path.

When the mute activates;

- On the analog cards, Q4EM, DFXS and DFXO, the audio path mutes and the signalling states go idle.
- On the digital cards, QV24 and HSS, it causes an all ones data pattern to be driven on the RXD output line and handshake lines such as RTS / CTS to their off states while on the QJET card it forces the ports to an AIS state.

The Modem Mute feature effectively reduces the radio receiver sensitivity by 2 to 3 dB from its published values but will prevent errors from corrupting the tributary audio circuits.

Modem Mute Time

The Modem Mute Time determines the time the mute will persist after the last uncorrectable block is received. This can be set from 0 to 10 seconds in 0.1 second steps.

Note: The Modem Mute feature is only available if the radio modem is Rev D or later. If the radio has a Rev A, Rev B or Rev C modem, the modem mute functionality is not displayed in SuperVisor.

Entering Basic Terminal Information

To enter basic terminal information:

Select Link or Local or Remote > Terminal > Basic

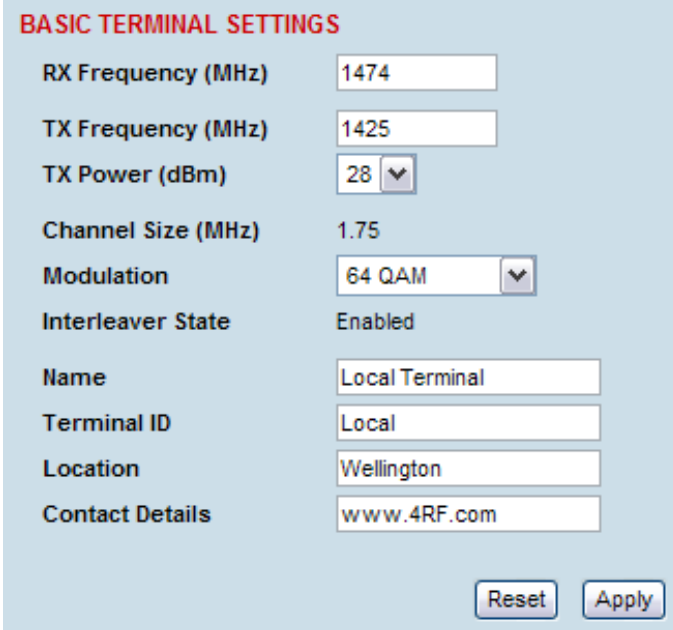

BASIC TERMINAL SETTINGS

RX Frequency (MHz)	<input type="text" value="1474"/>
TX Frequency (MHz)	<input type="text" value="1425"/>
TX Power (dBm)	<input type="text" value="28"/>
Channel Size (MHz)	<input type="text" value="1.75"/>
Modulation	<input type="text" value="64 QAM"/>
Interleaver State	Enabled
Name	<input type="text" value="Local Terminal"/>
Terminal ID	<input type="text" value="Local"/>
Location	<input type="text" value="Wellington"/>
Contact Details	<input type="text" value="www.4RF.com"/>

Terminal Information

The data entry in these four fields can be up to 40 characters but cannot contain back slashes or double quotes.

1. Enter the terminal Name. This appears in the Terminal status and menu bar at the top of every page.
2. Enter a unique Terminal ID.
3. Enter the Location of the terminal.
4. Enter a contact name or an email address in Contact Details. The default value is 'support@4RF.com'.
5. Click Apply to apply changes or Reset to restore the previous configuration.

Configuring the IP Settings

Select Link or Local or Remote > Terminal > Advanced.

ADVANCED TERMINAL SETTINGS

IP Address	<input type="text" value="192.168.0.77"/>
Subnet Mask	<input type="text" value="255.255.0.0"/>
Default Gateway	<input type="text" value="0.0.0.0"/>
Remote Address	<input type="text" value="192.168.0.78"/>
Remote Syslog Address	<input type="text" value="0.0.0.0"/>
Remote Syslog Port	<input type="text" value="514"/>
Time Zone Offset from GMT	<input type="text" value="Greenwich Mean Time Dublin, London, Edinburgh"/>
Time	<input type="text" value="Mon, 25 May 2009 13:05:34"/> <input type="button" value="Now"/>

Advanced Terminal Settings

1. Enter the static IP Address for the terminal assigned by your site network administrator using the standard format xxx.xxx.xxx.xxx. The default IP address is in the range 169.254.50.xx.
2. Enter the Subnet Mask for the terminal using the standard format xxx.xxx.xxx.xxx. The default subnet mask is 255.255.0.0.
3. Enter the Default Gateway for the terminal, if required, using the standard format xxx.xxx.xxx.xxx (there is no default gateway set by default.)
4. Enter the IP address of the remote terminal using the standard format xxx.xxx.xxx.xxx (the default IP address is in the range 169.254.50.xx.)
5. If you are setting up for remote logging (see 'Setting up for Remote Logging' on page 255), enter the Syslog Address and the Syslog Port for the remote terminal.
6. In Time Zone Offset from GMT, select the time zone from the list (optional) .
7. To set the Time to the PC real-time clock, click Now.
8. Click Apply to apply changes or Reset to restore the previous configuration.

Setting the Terminal Clocking

To view the terminal clock status:

Select Link or Local or Remote > Terminal > Clocking

The current selected clock source and the current status of the primary and secondary external clocks are shown:

Clock Status	Clock Status Description
Inactive	This clock source is either not configured at all, or is not in current use
Active	This clock source is providing the clocking for the terminal
Holdover	This clock source is nominated as Primary or Secondary but is currently unavailable.

CLOCKING

Clock Selection External

Primary External Clock

Source QJET Slot D Port 1

Status Active

Secondary External Clock

Source HSS Slot H

Status Holdover

Manual Override None

To select the terminal clock source:

The Clock Source selected for the terminal will be used to clock all interface ports requiring clocking and send a clocking signal over the RF link.

Select Link or Local or Remote > Terminal > Clocking > Clock Source and select one of the following:

Clock Source	Terminal Clocking
External	The terminal is clocked from the nominated interface port selected as the primary external clock or the secondary external clock.
Internal	The terminal is clocked from the terminal's internal clock.
Link	The terminal is clocked from the RF link.

If the terminal Clock Source is set to External, the terminal will automatically clock from the nominated primary external clock source if that clock source is available.

If the nominated primary external clock source is not available, the terminal will clock from the nominated secondary external clock source if that clock source is available.

If the nominated secondary external clock source is not available, the terminal will clock from the internal clock source.

When a nominated external clock source becomes available (primary or secondary), the terminal will then clock from that clock source.

The terminal at one end of the link must have its clock source set to Internal or External and the terminal at the other end of the link must have its clock source set to Link.

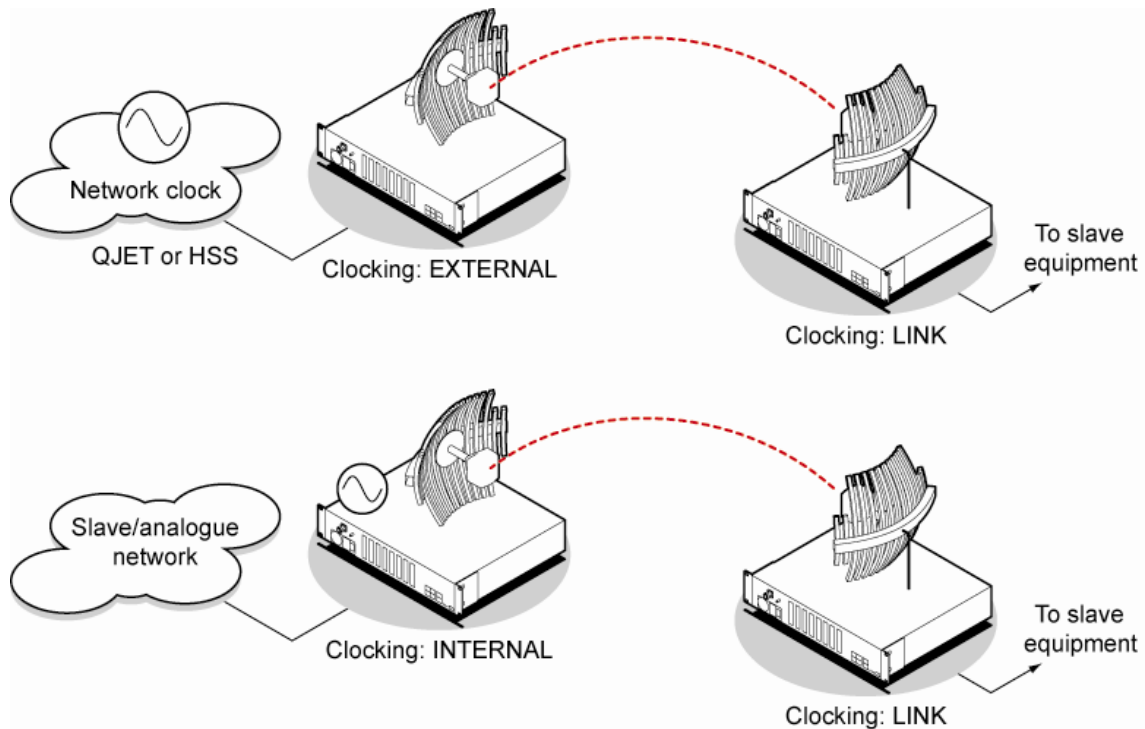

To select the interface port for the external clock source (external clock source only):

Select the traffic interface ports nominated as Primary External Clock or Secondary External Clock sources.

The failure of both External Clock sources results in a major alarm.

To manually override the automatic clock source selection (external clock source only):

Select either Switch to Primary or Switch to Secondary from the drop-down list, and click Apply.

Setting the Duplexer Parameters

To set the duplexer parameters:

Select Link or Local or Remote > Terminal > Duplexer

DUPLEXER SETTINGS

High Port Centre Frequency (MHz)	<input type="text" value="1474"/>
Low Port Centre Frequency (MHz)	<input type="text" value="1425"/>
Pass Band (MHz)	<input type="text" value="7"/>
Transmit	<input checked="" type="radio"/> High <input type="radio"/> Low
Serial Number	<input type="text" value="25215089"/>

Duplexer Parameters

The terminal TX and RX frequencies entered are validated against the duplexer parameters entered on this page.

A valid high port frequency must be:

$$\leq (\text{duplexer high port centre frequency} + \text{pass band}/2 - \text{channel size}/2)$$

and

$$\geq (\text{duplexer high port centre frequency} - \text{pass band}/2 + \text{channel size}/2)$$

A valid low port frequency must be:

$$\leq (\text{duplexer low port centre frequency} + \text{pass band}/2 - \text{channel size}/2)$$

and

$$\geq (\text{duplexer low port centre frequency} - \text{pass band}/2 + \text{channel size}/2)$$

The duplexer parameters are entered in the factory but can be re-entered if the duplexer is changed in the field. The parameters required are shown on the duplexer label.

1. Enter the duplexer High port centre frequency and Low port centre frequency in MHz.
2. Enter the duplexer Pass band in MHz (the total passband e.g. if the duplexer passband is show as ± 3.5 MHz, the value entered is 7 MHz).
3. Select Transmit High or Transmit Low
 Transmit High - the Transmitter is connected to the High Port of the duplexer.
 Transmit Low - the Transmitter is connected to the Low Port of the duplexer.
4. Enter the duplexer Serial Number (used for record keeping only).
5. Click Apply to apply changes or Reset to restore the previous configuration.

Setting the RSSI Alarm Threshold

The threshold (in dB) at which the RSSI alarm activates can be set for each of the modulation types over the adjustment range of -40 dBm to -110 dBm and the default values are as per the following screen shot. The alarm threshold has a +1 dB hysteresis for the inactive state.

To set the RSSI alarm threshold:

Select Link or Local or Remote > Alarms > RSSI Thresholds



RSSI THRESHOLDS	
QPSK (dBm)	-80
16 QAM (dBm)	-74
32 QAM (dBm)	-71
64 QAM (dBm)	-68

Reset Apply

1. Enter the alarm threshold required for each of the modulation types.
2. Click Apply to apply changes or Reset to restore the previous configuration.

Configuring the External Alarms

Each terminal has two external alarm inputs and four external alarm outputs, terminated on the ALARM RJ-45 connector on the terminal front panel.

Each external alarm input can activate the Major / Minor terminal alarm or be mapped to a remote terminal external alarm output.

The 'Alarm On When' (active alarm state) for both inputs can be configured for 'External Source On' or 'External Source Off' (default is External Source On).

Each external alarm output can be triggered by a local terminal Major / Minor alarm or a remote terminal Major / Minor alarm or either of the remote external alarm inputs.

The 'Relay Closed When' for the four outputs can be configured for 'Alarm On' or 'Alarm Off' (default is Alarm Off).

Configuring the External Alarm Inputs

To configure the External Alarm Inputs:

Select Link or Local or Remote > Alarms > Ext Alarm Inputs

Note: When the MHSB mode is enabled on the terminal, the external alarm input 2 is used for protection switch control so is not available for user alarms.

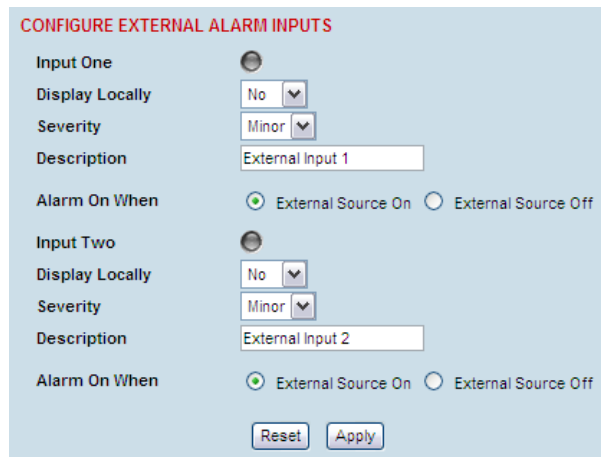

The state of the local terminal external alarm input is always sent to the remote terminal and the external alarm input can be mapped to a remote terminal external alarm output.

Alarms present on a local terminal external alarm input will only be displayed in the remote terminal Alarm Table / Alarm History if it has been mapped to one of the remote terminal external alarm outputs.

1. Select the **Display Locally** setting for each alarm input.

Display Locally	External Alarm Input Function	
No	The external alarm input does not generate an alarm on the local terminal, does not appear in the 'Alarm Table' or 'Alarm History', and shows as grayed out on the 'Alarm Summary'.	Default
Yes	The external alarm input generates an alarm on the local terminal, displays in the 'Alarm Table' and 'Alarm History' and the 'Alarm Summary'.	

2. Select the **Severity** setting for each alarm input.

This option is only relevant when the 'Display Locally' option is set to 'Yes'.

Severity	External Alarm Input Severity	
Minor	The external alarm input generates a minor alarm on the local terminal.	Default
Major	The external alarm input generates a major alarm on the local terminal.	

3. Enter a Description for each alarm input. The default is 'External Input 1' / 'External Input 2'.
4. Select the **Alarm On When** setting for each alarm input.

Alarm On When	External Alarm Input State	
External Source On	The alarm is on (alarm active) when a source of voltage is applied to the external alarm input and current is flowing.	Default
External Source Off	The alarm is on (alarm active) when no source of voltage is applied to the external alarm input and hence no current is flowing.	

5. When you have made your changes, click **Apply** to apply changes or **Reset** to restore the previous configuration.

Configuring the External Alarm Outputs

To configure the External Alarm Outputs:

Select Link or Local or Remote > Alarms > Ext Alarm Outputs

Note: When the MHSB mode is enabled on the terminal, the external alarm output 4 is used for protection switch control so is not available for user alarms.

1. Select the **Mapping** required for each alarm output.

Mapping	External Alarm Output Function	
None	No external alarm output.	Default
Local Major	The external alarm is present when the local terminal has a major alarm.	
Local Minor	The external alarm is present when the local terminal has a minor alarm.	
Remote Major	The external alarm is present when the remote terminal has a major alarm.	
Remote Minor	The external alarm is present when the remote terminal has a minor alarm.	
Remote Input 1	The external alarm is present when the remote terminal external alarm input 1 is present.	
Remote Input 2	The external alarm is present when the remote terminal external alarm input 2 is present.	
Test Major	External alarm test function - major alarm This setting will output an alarm on the selected output but it will not show in the alarm table or on the OK LED of the radio (it is not a 'real' alarm). This alarm test will clear if radio reboots.	
Test Minor	External alarm test function - minor alarm This setting will output an alarm on the selected output but it will not show in the alarm table or on the OK LED of the radio (it is not a 'real' alarm). This alarm test will clear if radio reboots.	

2. Select the **Relay closed when** setting for the four alarm outputs.

Relay closed when	External Alarm Output State	
Alarm on	When the external alarm output relay contact is closed, the alarm is on (alarm active).	Default
Alarm off	When the external alarm output relay contact is closed, the alarm is off (alarm inactive).	

3. When you have made your changes, click **Apply** to apply changes or **Reset** to restore the previous configuration.

Configuring SNMP Settings

In addition to web-based management (SuperVisor), the terminal can also be managed using the Simple Network Management Protocol (SNMP). MIB files are supplied, and these can be used by a dedicated SNMP Manager, such as Castle Rock's SNMPc (www.castlerock.com), to access most of the terminal's configurable parameters.

However, it is recommended that SNMP is only used for status and alarm monitoring of your entire network. SuperVisor is the best means to configure individual terminals.

For communication between the SNMP manager and the terminal, Access Controls, Trap Destinations, and Community strings must be set up as described in the following sections.

A **SNMP Access Control** is the IP address of the terminal used by an SNMP manager or any other SNMP device to access the terminal. Entering an IP address of 'Any' (not case sensitive) or * will allow any IP address access to the terminal. A community string is sent with the IP address for security.

Commands are sent from the SNMP manager to the terminal to read or configure parameters of the terminal e.g. setting of interface parameters.

A **SNMP Trap Destination** is the IP address of a station running an SNMP manager. A community string is sent with the IP address for security.

Events are sent from the terminal to the SNMP manager e.g. alarm events.

A **SNMP Community String** is used to protect against unauthorized access (similar to a password). The SNMP agent (terminal or SNMP manager) will check the community string before performing the task requested in the SNMP message . Trap Destinations and Access Controls both use community strings for protection.

To configure Trap Destinations and Access Controls:

Select Local > Maintenance > SNMP > SNMP Settings

SNMP SETTINGS

ACCESS CONTROL SETUP

Type	Address	Community	Select
Read Only	192.168.0.67	AprisaRO	<input type="radio"/>
Read/Write	192.168.0.68	AprisaRW	<input type="radio"/>

TRAP DESTINATION SETUP

Type	Address	Community	Select
SNMPv1	192.168.0.70	AprisaXE	<input type="radio"/>
SNMPv2c	192.168.0.71	AprisaXE	<input type="radio"/>

Note: SNMP Settings can only be setup on the local terminal.

SNMP Access Controls

To add an access control:

1. Click on the 'Add Read Only' button to enter a Read Only access control or click on the 'Add Read/Write' button to enter a Read/Write access control.



ADD READ/WRITE ACCESS CONTROL

Address

Community

Add

2. Enter the IP address of each SNMP manager allowed access to the terminal (read/write access control shown). The IP address entered must be a valid dot delimited IP address.

Entering an IP address of 'Any' or * will allow any IP address access to the terminal.

3. Enter the community string for the access control.

The Community string is usually different for Read Only and Read/Write operations.

There is no default 'public' community string for an access control, but a 'public' community string can be entered which will have full MIB access, including the 4RF MIB.

4. Click Add.

To delete an access control:

1. Select the access control you want to delete and click Delete.



2. Click OK to delete the access control or Cancel to abort the delete.

SNMP Trap Destinations

To add a trap destination:

1. Click on the 'Add SNMPv1' button to enter a SNMPv1 trap destination or click on the 'Add SNMPv2c' button to enter a SNMPv2c trap destination.

The differences between SNMPv1 and SNMPv2c are concerned with the protocol operations that can be performed. Selection of SNMPv1 and SNMPv2c must match the setup of the SNMP manager.



ADD SNMPV1 TRAP DESTINATION

Address

Community

2. Enter the IP address of the server to which you want SNMP traps sent (SNMPv1 trap destination shown). The IP address entered must be a valid dot delimited IP address.

3. Enter the community string for the trap destination.

There is no default 'public' community string for a trap destination, but a 'public' community string can be entered.

4. Click Add.

To delete a trap destination:

1. Select the trap destination you want to delete and click Delete.



2. Click OK to delete the trap destination or Cancel to abort the delete.

Viewing the SNMP Traps

Any event or alarm in the SNMP objects list can be easily viewed. This also enables you to verify, if required, that SNMP traps are being sent.

Select Local > Maintenance > SNMP > View Traps.

VIEW SNMP TRAPS - MOST RECENT FIRST

Up Time	(50734553) 5 days, 20:55:45.53
Trap OID	aprisaXEV24ControlLineLossEvent
aprisaXEEventCardSlot.0	slotG
aprisaXEEventCardPort.0	portTwo
aprisaXEEventAlarmStatus.0	noAlarmPresent
Up Time	(50734547) 5 days, 20:55:45.47
Trap OID	aprisaXEV24ControlLineLossEvent
aprisaXEEventCardSlot.0	slotG
aprisaXEEventCardPort.0	portOne
aprisaXEEventAlarmStatus.0	noAlarmPresent

Viewing the SNMP MIB Details

This is useful to see what MIB (Management Information Base) objects the terminal supports.

Select Link or Local or Remote > Maintenance > SNMP > View MIB Details.

VIEW MIB DETAILS

MIB Identifier	Description
mib-2.31	The MIB module to describe generic objects for network interface sub-layers
snmpMIB	The MIB module for SNMPv2 entities
mib-2.49	The MIB module for managing TCP implementations
ip	The MIB module for managing IP and ICMP implementations
mib-2.50	The MIB module for managing UDP implementations
vacmBasicGroup	View-based Access Control Model for SNMP.
snmpFrameworkMIBCompliance	The SNMP Management Architecture MIB.
snmpModules.11.3.1.1	The MIB for Message Processing and Dispatching.
snmpModules.15.2.1.1	The management information definitions for the SNMP User-based Security Model.
fourRFCommon	4RF Common MIB
fourRFAprisaXE	4RF AprisaXE specific MIB

Saving the Terminal's Configuration

Note: To save cross connection configurations, see page 155.

To save a configuration:

1. Ensure you are logged in with either 'modify' or 'admin' privileges.
2. Select Local > Maintenance > Config Files > Save MIB.
3. Select the 'Save to disk' option in the dialog box that appears.
4. In the next dialog box that appears, navigate to the directory where you want to save the file, enter a suitable filename, and then click Save (The default name for this file is backupForm).

Note 1: If this dialog box does not appear, change your Internet security settings to allow downloads. You may also need to check your default download location.

Note 2: Pop-ups must be enabled on you PC for this function to work (see 'PC Settings for SuperVisor' on page 50).

To load a configuration into a terminal:

Important: Only load a saved configuration file to another terminal that has exactly the same configuration (RF variant and interface cards).

1. Ensure you are logged in with either 'modify' or 'admin' privileges.
2. Select Local or Remote > Maintenance > Config Files > Load MIB.

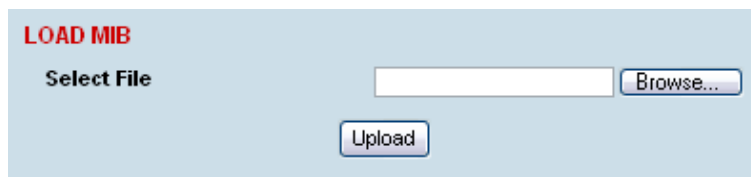

The screenshot shows a light blue dialog box titled "LOAD MIB" in red text. Below the title, the text "Select File" is displayed. To the right of "Select File" is a white text input field. To the right of the input field is a button labeled "Browse...". Below the input field and "Browse..." button is a button labeled "Upload".

3. Click Browse and then navigate to the file and select it.
4. Click Upload to load the configuration file into the terminal.

9. Configuring the Traffic Interfaces

Important: When configuring a link, it is important that you configure the remote terminal first as the new configuration may break the management connection to the remote terminal.

Once the remote terminal has been configured, the local terminal should be configured to match the remote terminal.

Viewing a Summary of the Interfaces

To view a summary of the interfaces fitted:

Select Link or Local or Remote > Interface > Interface Summary.

INTERFACE SUMMARY							
Slot	Type	Port 1 (kbps)	Port 2 (kbps)	Port 3 (kbps)	Port 4 (kbps)	Status	Select
A	None	0	0	0	0	●	<input checked="" type="radio"/>
B	None	0	0	0	0	●	<input type="radio"/>
C	Q4EM	72	72	72	72	●	<input type="radio"/>
D	QJET	72	96	0	0	●	<input type="radio"/>
E	DFXD	72	64	0	0	●	<input type="radio"/>
F	DFXD	0	0	0	0	●	<input type="radio"/>
G	QV24	24	32	48	0	●	<input type="radio"/>
H	HSS	1088	0	0	0	●	<input type="radio"/>

STATISTICS	
Total Capacity (kbps)	8632
Ethernet Capacity (kbps)	256
Management Capacity (kbps)	64
Allocated Capacity (kbps)	24% (2104 of 8632)
Drop & Insert (kbps)	0% (0 of 63432)

The Interface Summary page shows:

- The interface type for each slot that has been configured with the capacity used by each port.
- **Total Capacity.** The total capacity of the radio link.
- **Ethernet Capacity.** The capacity allocated to the Ethernet traffic over the radio link. This includes the user and management capacity assigned.
- **Management Capacity.** The capacity allocated to the management conduit over ethernet.
- **Radio Capacity.** The percentage of the total capacity of the radio link that has been allocated to traffic interfaces.
- **Drop and insert capacity.** The percentage of the total drop and insert capacity used for local drop and insert cross connections. The total drop and insert capacity is 65536 kbit/s minus the assigned radio link capacity.

Some interfaces also require extra bandwidth to be allocated to transport signalling, such as CTS / DTR handshaking or E&M signals. The cross connections application automatically allocates capacity for signalling when it is needed.

Configuring the Traffic Interfaces

Important: Before you can configure the traffic interfaces, the interface cards must be already installed (see ‘Installing Interface Cards’ on page 235).

Configuring each traffic interface involves the following steps (specific instructions for each interface card follow this page).

First, specify the port settings for the Remote terminal:

1. Select Remote > Interface > Interface Summary, select the interface card and click Configure Interface.
2. Select the port you want to configure and modify the settings, as necessary.
3. Click Apply to save the changes you have made.

Now specify the port settings for the Local terminal:

1. Select Local > Interface > Interface Summary, select the interface card and click Configure Interface.
2. Select the port you want to configure and modify the settings, as necessary.
3. Click Apply to save the changes you have made.

Once you have done this, you will need to configure the traffic cross-connects (see ‘Configuring the traffic cross connections’ on page 145) for each interface card.

Ethernet Switch

In the default mode, the Ethernet switch passes IP packets (up to 1522 bytes) as it receives them. However, using SuperVisor you can configure VLAN, QoS and port speed settings to improve how IP traffic is managed.

This is useful for operators who use virtual networks to segment different groups of users or different types of traffic in their network. These groups can be maintained across the radio link thus ensuring users in one virtual network cannot access data in other virtual networks.

The switch also has a high-speed address lookup engine, supporting up to 2048 preferential MAC addresses as well as automatic learning and aging. Traffic is filtered through this table and only traffic destined for the remote end is sent across the link improving bandwidth efficiency.

Note: You need ‘modify’ or ‘admin’ privileges to configure the Ethernet for VLAN and Quality of Service (QoS).

VLAN tagging

By default, all user and management traffic is allocated the same VLAN across the link.

Alternatively, you can assign each of the four Ethernet ports to a VLAN. Each VLAN can be configured to carry user traffic, or user traffic and radio management traffic. The VLAN tagging conforms to IEEE 802.1Q standard.

Configuring the Ethernet switch for VLAN tagging

1. Select Link or Local or Remote > Interface > Ethernet Settings.

Note: Always configure the remote terminal before the local terminal

2. In the Quick Links box at the bottom of the page, click Ethernet General Settings.

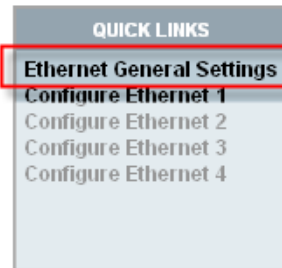

3. From Ethernet Grouping drop-down list select 'Enabled' ('Disabled' is the default setting; Ethernet traffic is not segregated).

Important: Changing this setting will disrupt Ethernet traffic.

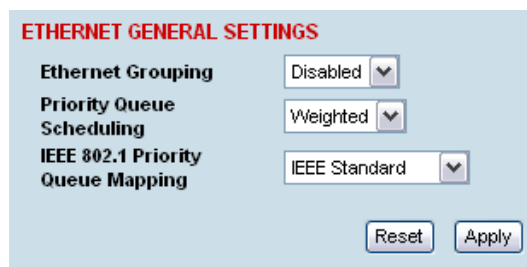

4. Click Apply to apply changes or Reset to restore the previous configuration.

You now need to select the VLAN groups for each of the four Ethernet ports.

Specifying the VLAN ID for the Ethernet Ports

Each Ethernet port can be configured with one of five VLAN IDs. You can configure each of the physical ports, numbered 1 to 4 with a VLAN ID (numbered User1 to User4 and User+Mgmt).

These VLAN IDs are applied at the ingress port and only used internally across the link. The VLAN ID is removed when traffic exits the switch at the egress port. Data entering the Ethernet switch on ports 1 to 4 or the internal management port can only exit on ports that are associated with the same VLAN ID as the ingress port.

For example, the physical RJ-45 port 1 may be on VLAN 3 at the local end, but at the remote end, the physical RJ-45 port 4 may be associated with VLAN 3. Traffic entering the local end on port 1 will exit the remote end on port 4.

To allow the radio link to transport traffic using existing VLAN ID information, the radio adds an extra VLAN ID over the top of an existing VLAN ID (double-tagging). This extra VLAN ID is added at the ingress port and removed at the egress port. This adds 4 bytes to the packet and the maximum packet size supported by the radio is 1526 bytes.

Note 1: Tagged flows can only have one port per VLAN ID on each terminal.

Note 2: The ethernet switch only supports packets up to 1522 bytes in size at the ingress port.

1. Select Link or Local or Remote > Interface > Ethernet Settings.

Note: Always configure the remote terminal before the local terminal

2. In the Quick Links box at the bottom of the page, select the port you want to configure:

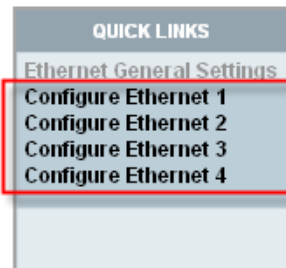

3. The Ethernet Port Settings page appears for the port you selected:

ETHERNET PORT SETTINGS

Ethernet Port 1

Ethernet Group

Ingress Rate

Priority

4. From the Ethernet Group drop-down list, select the VLAN group to which you want this port to belong.

Important: To access radio management traffic, you need to allocate one of the VLANs to 'User and Management'. It is strongly recommended that you indicate which port or group of ports is associated to the management traffic first.

5. Click Apply.
6. Repeat steps 1-4 for the Ethernet switch in the other terminal in the link.

Quality of Service

Quality of Service (QoS) enables network operators to classify traffic passing through the Ethernet switch into prioritized flows.

Each port can have a priority tag set at the ingress port, or it can be read directly from the Ethernet traffic. When read directly from the Ethernet traffic, the following fields are used to determine the traffic's QoS priority.

- The IEEE 802.1p Priority information in the IEEE 802.3ac Tag.
- The IPv4 Type of Service field.
- The IPv6 Traffic Class field.

You can select one of two queuing methods:

- IEEE 802.1p standard method
- Cisco-proprietary method

The queuing method determines how the traffic is prioritized.

Each port has four egress queues (queues 0-3) of differing priorities. Queue 0 is the lowest priority and Queue 3 is the highest priority.

Configuring the Ethernet Switch for QoS

1. Select Link or Local or Remote > Interface > Ethernet Settings.
2. In the Quick Links box at the bottom of the page, click Ethernet General Settings.

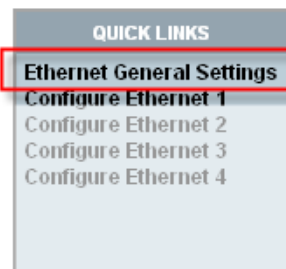

The Ethernet General Settings page:

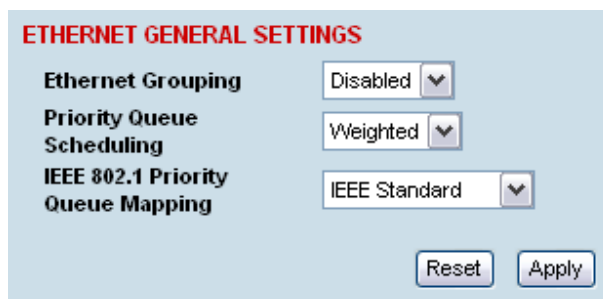

3. Leave Ethernet Grouping set to 'Disabled' (unless you want to enable VLAN tagging).

4. Select the Priority Queue Scheduling.

There are two methods for transmitting the Ethernet traffic queues across the link:

- **Strict:** the queue is transmitted based on the priority. The first queue transmitted is the highest priority queue and the terminal will not transmit any other traffic from any other queue until the highest priority queue is empty. Then the next highest priority queue is transmitted, and so on.
- **Weighted (default):** each of the queues will transmit a number of packets based on a weighting. The following table shows how the weighting is applied to each queue.

Queue	Priority	Number of packets transmitted
Queue 3	Highest Priority	8 packets
Queue 2		4 packets
Queue 1		2 packets
Queue 0	Lowest Priority	1 packets

5. Select the IEEE 802.1 Priority Queue Mapping.

This determines the standard (or scheme) used for prioritizing traffic into one of four queues numbered 0 to 3 (3 being the highest priority queue).

There are two possible methods for queuing the ethernet traffic. One is based on the IEEE 802.1D standard (which is the default setting), and the other is based on the Cisco-proprietary method.

The following table shows how traffic is queued using the two methods:

Priority	Traffic Type	Output Queue	
		Cisco Priority Queuing	IEEE 802.1D Priority Queuing
0 (default)	Best Effort	0	1
1	Background	0	0
2	Spare	1	0
3	Excellent Effort	1	1
4	Controlled Load	2	2
5	'Video' < 100ms latency and jitter	2	2
6	'Video' < 10ms latency and jitter	3	3
7	Network Control	3	3

Configuring the Ethernet Ports for QoS

Each Ethernet port can be configured for Ingress Rates and Priority queues.

To configure the Ethernet ports for QoS:

1. Select Link or Local or Remote > Interface > Ethernet Settings.

ETHERNET SETTINGS

Ethernet Port	Ethernet Group	Ingress Rate	Priority	Select
1	User + Mgmt	Unlimited	From Frames	<input checked="" type="radio"/>
2	User + Mgmt	Unlimited	From Frames	<input type="radio"/>
3	User 3	256 kbps	Medium	<input type="radio"/>
4	User + Mgmt	Unlimited	From Frames	<input type="radio"/>

[Port Configuration...](#)

ETHERNET GROUP SETTINGS

Ethernet Grouping Enabled

QoS

Priority Queue Scheduling Weighted

IEEE 802.1 Priority Queue Mapping IEEE Standard

2. Select the port you want to configure and click Port Configuration.

ETHERNET PORT SETTINGS

Ethernet Port 1

Ethernet Group User + Mgmt

Ingress Rate Unlimited

Priority From Frames

3. Select the required Ingress Rate for this port.

The ingress rate (input data rate) limits the rate that traffic is passed into the port. Operators can protect the terminal's traffic buffers against flooding by rate-limiting each port.

Ingress Rate	
Unlimited	Default
128 kbit/s	
256 kbit/s	
512 kbit/s	
1 Mbit/s	
2 Mbit/s	
4 Mbit/s	
8 Mbit/s	

4. Select the Priority for all Ethernet data entering this port.

The priority specifies where the priority control information is sourced from.

From Frames

Traffic is prioritized into one of the following traffic types (numbered 0 to 7) by the originating device or application. Generally, the higher the priority, the higher the priority rating.

However, in the IEEE standard queuing scheme, the ordering of the priority is 1, 2, 0, 3, 4, 5, 6, 7. In this case 0 has a higher priority than 1 and 2.

If priority control information is present in the Ethernet header, this information is used to priorities the traffic but if there is no priority control information in the Ethernet header, the IP header is used to priorities the traffic.

Low, Medium, High, Very High

The priority rating you select is applied to all traffic on the port and is applied to all traffic irrespective of traffic type and the priority control information in the traffic.

5. Click Apply to apply changes or Reset to restore the previous configuration.

Viewing the Status of the Ethernet Ports

Select Link or Local or Remote > Interface > Switch Summary.

ETHERNET HUB STATUS			
Port	Speed	Duplex	Status
1	100 Mbps	Full	Active
2	10 Mbps	Half	Active
3	10 Mbps	Half	Inactive
4	10 Mbps	Half	Inactive

For each port the following is shown:

- Speed – the data rate (in Mbit/s) of the port.
- Duplex – whether half or full duplex.
- Status – whether there is a cable plugged into the port (active) or not (inactive).

Note: The Ethernet ports on the terminal are set to auto-configure the speed and duplex for the best performance.

Resetting the Ethernet Settings

You can easily reset the VLAN and QoS settings to the default values, if required. This is useful if you want the Ethernet switch to operate in the default mode, that is, IP packets are passed across the link as received.

Note: You can also do this using the Setup menu (see page 57.).

1. Select Link or Local or Remote > Interface > Default Ethernet Settings.

DEFAULT ETHERNET SETTINGS

Set Ethernet Groupings To Default Values

Set Ethernet QoS To Default Values

Set Ethernet Groupings To Default Values.

This resets the Ethernet Grouping setting to 'Disabled', which means that the Ethernet switch no longer operates as a VLAN. In addition, all the Ethernet ports will default to the 'User and Management' Ethernet Group.

Set Ethernet QoS To Default Values.

This resets the ingress rate for all the ports to 'Unlimited' and the priority to 'From Frames'. In addition, the Ethernet QoS settings are reset to the defaults: Priority Queue Scheduling reverts to 'Weighted' and IEEE 802.1 Priority Queue Mapping reverts to 'IEEE Standard'.

2. Click Apply to apply changes or Reset to restore the previous configuration.

Ethernet Port Startup

In previous Aprisa XE software versions, the Ethernet switch ports were enabled when the radio powered up.

In software version 8.6.53, the mode of operation was changed to disable the Ethernet switch ports until the radio software has completed booting. This enhancement has been implemented to meet customer requirements.

A hardware modification is required to the Aprisa XE motherboard to enable this enhancement (0 ohm resistor fitted).



If the Aprisa XE motherboard hardware modification has been done, the Aprisa XE software version 8.6.53 or greater will be required to operate the radio. If Aprisa XE software prior to this version is used, the Ethernet ports will not enable. For this reason, an Aprisa XE running software version 8.6.53 cannot be downgraded to an earlier software version.

QJET Port Settings

1. Select Link or Local or Remote > Interface > Interface Summary, then select the QJET interface and click Configure Interface.

QJET INTERFACE PORTS SUMMARY

Slot	Port	Loopback	Type	Line Encoding	PCM Mode	Select
D	1	Off	T1	B8ZS	T1 ESF - PTS	<input checked="" type="radio"/>
D	2	Off	E1	HDB3	PCM 30	<input type="radio"/>
D	3	Off	None	HDB3	Off	<input type="radio"/>
D	4	Off	None	B8ZS	Off	<input type="radio"/>

[Edit...](#)

2. Select the QJET port to be configured and click Edit.

CONFIGURE QJET INTERFACE PORTS

Slot: D

Port: 2

Type: E1

PCM Mode: PCM 30

Line Encoding:

Loopback:

AIS Hysteresis:

[Reset](#) [Apply](#)

CONFIGURE QJET INTERFACE PORTS

Slot: D

Port: 1

Type: T1

PCM Mode: T1 ESF - PTS

Line Encoding:

Tx Waveform Shaper:

Loopback:

AIS Hysteresis:

[Reset](#) [Apply](#)

3. Set the QJET Line Encoding:

For an E1 port, set the E1 Line Encoding as required to either HDB3 or AMI. The default is HDB3.

For a T1 port, set the T1 Line Encoding as required to either B8ZS or AMI. The default is B8ZS.

4. Set the QJET T1 Tx Waveform Shaper (T1 only).

The Tx Waveform Shaper applies $1/f$ pre-emphasis to the transmit waveform to ensure the waveform meets the G.703 pulse mask at the interconnect point. Waveform shaping assumes the use of 22 gauge (0.32 mm²) twisted-pair cable. The default is 0 ~ 133 ft.

Cable Length Range	
0 ~ 133 ft	Default
133 ~ 266 ft	
266 ~ 399 ft	
399 ~ 533 ft	
533 ~ 655 ft	

5. Loopback controls the port loopbacks (see 'Interface Loopbacks' on page 242).

Setting	Function
Off	No port loopback
Line Facing	Port traffic from the customer is transmitted over the RF link but is also looped back to the customer
Radio Facing	Traffic received from the RF link is passed to the customer port but is also looped back to be transmitted over the RF link

Note: The QJET E1 / T1 port green LED flashes when the loopback is active.

- 6. AIS Hysteresis sets the number of seconds after a Modem LOS that AIS is sent.
- 7. Click Apply to apply changes or Reset to restore the previous configuration.

Q4EM Port Settings

1. Select Link or Local or Remote > Interface > Interface Summary, select the Q4EM interface, and click Configure Interface.

Q4EM PORT SUMMARY

Slot	Port	PCM Mode	Input Level (dBr)	Output Level (dBr)	E&M	E-wire	M-wire	Loopback	Select
C	1	64 kbit/s PCM	-8.0	+4.0	On	Normal	Normal	Off	<input checked="" type="radio"/>
C	2	64 kbit/s PCM	+0.0	+0.0	On	Normal	Normal	Off	<input type="radio"/>
C	3	Off	+0.0	+0.0	Off	Normal	Normal	Off	<input type="radio"/>
C	4	Off	+0.0	+0.0	Off	Normal	Normal	Off	<input type="radio"/>

2. Select the Q4EM port to be configured, and click Edit.

Q4EM PORT CONTROL

Slot: C

Port: 1

PCM Mode: 64 kbit/s PCM

Input Level (dBr):

Output Level (dBr):

E&M: On

E-wire: Normal Invert

M-wire: Normal Invert

Loopback:

'Slot' shows the slot the Q4EM interface card is plugged into in the terminal (A - H).

'Port' shows the interface port number (1-4).

'PCM Mode' shows the current mode assigned to the port by the cross connect.

'E&M' shows if the E&M signalling on the port has been activated by the cross connect.

'Loopback' controls the 4 wire analogue port loopbacks.

3. Set the Q4EM Output level and the Input level required.

Signal Direction	Level adjustment range	Default setting
Input level (L _i)	-14.0 dBr to +4.0 dBr in 0.5 dB steps	+0.0 dBr
Output level (L _o)	-14.0 dBr to +4.0 dBr in 0.5 dB steps	+0.0 dBr

It is important that analogue signals presented from the Q4EM interface be normalized to fit within the ± 127 quantizing steps of the encoder. This is done by adjusting the circuit levels relative to the 0 dBm (± 118 peak code) for example:

- If a nominal input level of -6.0 dBm is applied to the Q4EM interface input port, the Q4EM Input Level must be set to -6.0 dBr. This will effectively amplify the sent signal by 6.0 dB to produce a digital signal with a ± 118 peak code (0 dBm).
- If a nominal output level of -6.0 dBm is required from the Q4EM interface output port, the Q4EM Output Level must be set to -6.0 dBr. This will effectively attenuate the received decoded signal by 6 dB.

4. Set the Q4EM E wire interface to either Normal or Inverted.

This determines the state of the CAS bit relative to the state of the E wire:

E wire output	CAS bit Normal (default)	CAS bit Inverted
Output Active	0	1
Output Inactive	1	0

5. Set the Q4EM M wire interface to either Normal or Inverted.

This determines the state of the CAS bit relative to the state of the M wire:

M wire input	CAS bit Normal (default)	CAS bit Inverted
Input Active	0	1
Input Inactive	1	0

6. Click Apply to apply changes or Reset to restore the previous configuration.

7. Select Q4EM PCM Law Control from the Quick Links box.

This option sets the companding law used by the four ports on the Q4EM card.



- A-Law is used internationally (default).
- μ-Law is used in North America and Japan.

Note: The PCM Law Control controls all four ports on the Q4EM card. To run a mixture of μ-Law and A-Law interfaces, multiple Q4EM cards are necessary.

8. Loopback controls the port loopbacks (see 'Interface Loopbacks' on page 242).

Setting	Function
Off	No port loopback
Line Facing	Port traffic from the customer is transmitted over the RF link but is also looped back to the customer
Radio Facing	Traffic received from the RF link is passed to the customer port but is also looped back to be transmitted over the RF link

Loop Interface Circuits

DFXO / DFXS Loop Interface Circuits

Function

The function of DFXO / DFXS 2 wire loop interface circuits is to transparently extend the 2 wire interface from the exchange line card to the telephone / PBX, ideally without loss or distortion.

The DFXO interface simulates the function of a telephone and a DFXS interface simulates the function of an exchange line card. These circuits are known as 'ring out, dial in' 2 wire loop interface circuits.

Network Performance

The overall Network Performance is dependant on the number of D-A and A-D conversions and 2 wire to 4 wire / 4 wire to 2 wire conversions in the end to end circuit (telephone to telephone). To achieve the best overall Network Performance, the number of D-A and A-D conversions and 2 wire to 4 wire / 4 wire to 2 wire conversions should be minimized.

Circuit Performance

The circuit quality achieved with a 2 wire voice circuit is very dependant on the external interface parameters and the interconnecting copper line.

Short interconnecting copper lines (< 100 meters), have little effect on the circuit performance so the interface parameters have the dominant affect on circuit performance.

As the length of the interconnecting copper line is increased, the attenuation of the analogue signal degrades circuit performance but also the impedance of the copper line also has a greater effect on the circuit performance. For this reason, complex line impedance networks (e.g. TBR21, TN12) were created which model the average impedance of the copper network.

The factors that affect the quality of the circuit achieved are;

DFXO interface

- The degree of match between the DFXO line termination impedance, the impedance of the interconnecting copper line and the exchange line card line termination impedance. This affects the return loss.
- The degree of match between the DFXO line termination impedance, the impedance of the interconnecting copper line and the exchange line card hybrid balance impedance. This affects the exchange line card transhybrid balance.
- The degree of match between the DFXO hybrid balance impedance, the impedance of the interconnecting copper line and the exchange line card line termination impedance. This affects the DFXO transhybrid balance.
- The circuit levels of both the DFXO and the exchange line card.

DFXS interface

- The degree of match between the DFXS line termination impedance, the impedance of the interconnecting copper line and the telephone line termination impedance. This affects the return loss.
- The degree of match between the DFXS line termination impedance, the impedance of the interconnecting copper line and the telephone hybrid balance impedance. This affects the telephone transhybrid balance.
- The degree of match between the DFXS hybrid balance impedance, the impedance of the interconnecting copper line and the telephone line termination impedance. This affects the DFXS transhybrid balance.
- The circuit levels of both the DFXS and the telephone.

Line Termination Impedance

The line termination impedance (Z_t) is the impedance seen looking into the DFXO or DFXS interface. The line termination impedance is not the same as the hybrid balance impedance network (Z_b) but can be set to the same value.

Changing the DFXO / DFXS impedance setting on the Aprisa XE changes both the line termination impedance and the hybrid balance impedance to the same value.

Hybrid Balance Impedance

The hybrid balance impedance (Z_b) is the impedance network on the opposite side of the hybrid from the DFXO / DFXS line interface. The purpose of this network is to balance the hybrid to the impedance presented to the DFXO / DFXS line interface.

Changing the DFXO / DFXS impedance setting on the Aprisa XE changes both the line termination impedance and the hybrid balance impedance to the same value.

Transhybrid loss

Transhybrid loss is a measure of how much analogue signal received from the remote terminal is passed across the hybrid and sent to the remote terminal.

The transhybrid loss is maximized when the hybrid balance impedance matches the impedance presented to the DFXO / DFXS line interface. An optimized hybrid minimizes circuit echo.

Circuit Levels

The 8 bit digital word for each analogue sample encoded (A law), has a maximum of 255 quantizing code steps, a maximum of + 127 for positive signals and a minimum of - 127 for negative signals. No signal is represented by the code step 0.

A nominal level of 0 dBm generates a peak code of ± 118 which allows up to + 3.14 dBm0 of headroom before the maximum step of 127 is obtained. Any level greater than + 3.14 dBm0 will be distorted (clipped) which will cause severe problems with analogue data transmission.

It is therefore important that analogue signals presented from the DFXO / DFXS line interface be normalized to fit within the ± 127 quantizing steps of the encoder. This is done by adjusting the circuit levels relative to the 0 dBm (± 118 peak code) for example:

- If a nominal input level of +1 dBm is applied to the DFXS line interface, the DFXS Input Level must be set to +1.0 dBr. This will effectively attenuate the sent signal by 1 dB to produce a digital signal with a 118 peak code (0 dBm).
- If a nominal output level of -6 dBm is required from the DFXS line interface, the DFXS Output Level must be set to -6.0 dBr. This will effectively attenuate the received signal by 6 dB.

The circuit levels and the transhybrid loss of both ends of the circuit, also determine the stability of the circuit. If the circuit levels are too high and the transhybrid loss figures achieved are too low, the circuit can have a positive loop gain and can recirculate (sometimes called singing).

Typically, an end to end 2 wire voice circuit is engineered to have a 2-3 dB loss in both directions of transmission.

Derived System Level Plan

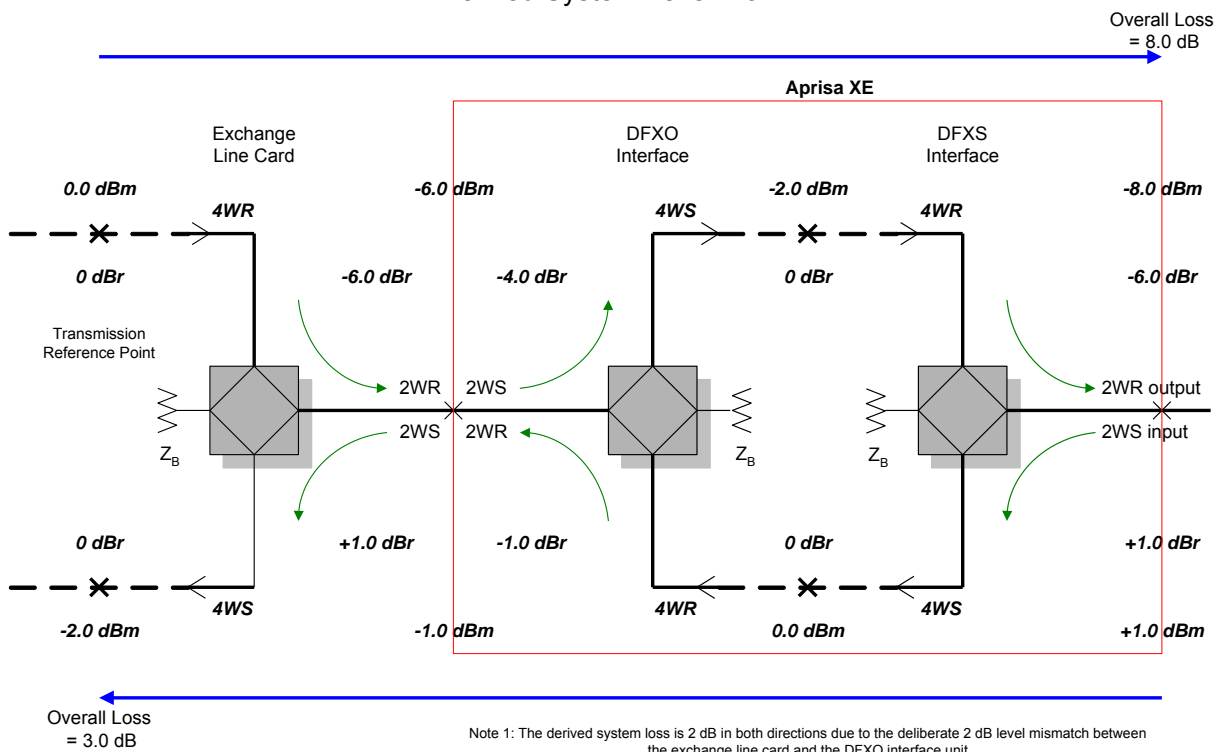

E1 CAS to DFXS Circuits

Function

E1 CAS to DFXS circuits can be provisioned over an Aprisa XE link by using a DFXS interface card at the customer end of the link and a QJET at the exchange end of the link. The QJET E1 interface connects to an exchange or PBX Digital Trunk Interface (DTI) to provide FXS foreign exchange circuits.

The Aprisa XE can interconnect at E1 to an exchange / PBX DTI if the DTI is capable of providing standard 1 bit channel associated signalling (CAS).

Forward	Af	Backward	Ab
Idle	1	Idle	1
Ringing	0	Loop (Off hook)	0

The signalling functions provided with a 1 bit CAS protocol are:

- Ring cadence transmission
- Ring trip
- Off hook
- Switch hook flash
- Decadic dialling

The speech path functions as normal and provides:

- Transmission of tones (e.g. dial tone, ring tone)
- Caller ID
- DTMF dialling
- Speech

Setup

Cross connect the voice channel between the QJET and the DFXS card.

Cross connect the signalling (A bit only) using '4 wire compatible' mode between the QJET and the DFXS card.

Configure the E1 spare CAS bits to be compatible with the DTI (see 'QJET Spare CAS Bit Control' on page 165). The standard spare bit states are B = 1, C = 0, D = 1.

DFXS to DFXS Hotline Circuits

Function

A 'Hotline' circuit can be provisioned over an Aprisa XE link by using a DFXS interface card at both ends of the link. When one phone goes off hook, the other phone rings and vice versa.

A 1 bit CAS protocol is used to signal between the DFXS interfaces:

Forward	Af	Backward	Ab
Idle	1	Idle	1
Ringing	0	Loop (Off hook)	0

Setup

Cross connect the voice channel on both DFXS cards.

Cross connect the signalling (A bit only) using '4 wire compatible' mode on both DFXS cards.

DFXS Port Settings

1. Select Link or Local or Remote > Interface > Interface Summary, then select the DFXS interface and click Configure Interface.

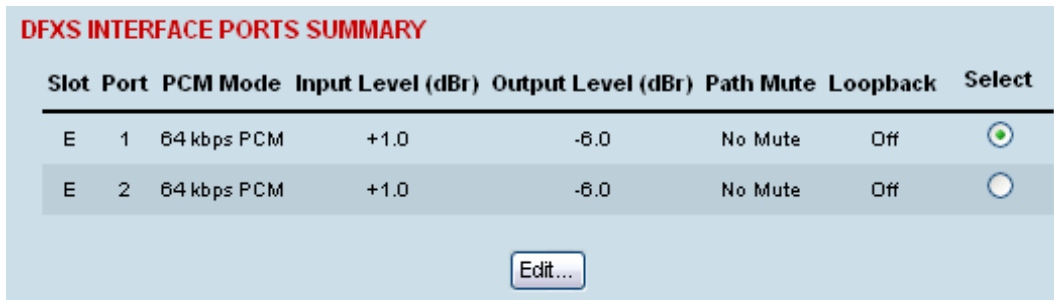

2. Select the DFXS port to configure, and click Edit.

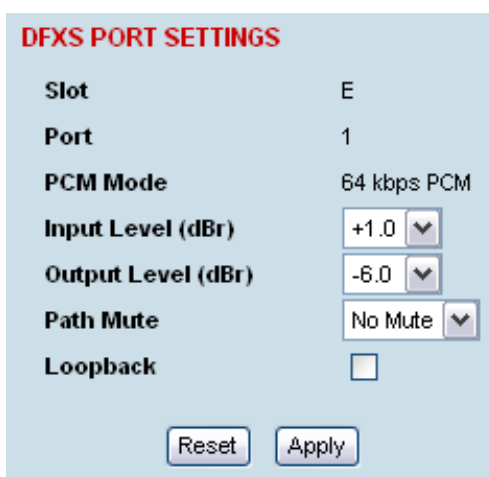

'Slot' shows the slot the DFXS interface card is plugged into in the terminal (A - H).

'Port' shows the interface port number (1-2).

'PCM Mode' shows the current mode assigned to the port by the cross connect.

'Loopback' loops back the port digital paths to return the port analogue signal back to the customer.

'Path Mute' mutes the TX or RX digital path. This function is used to mute the return direction of transmission during A-A intrinsic performance testing as recommended in ITU G.712 para 1.2 Port definitions.

Path Mute	Description	
No Mute	Normal signal transmission in both directions	Default
Mute TX	Mutes the transmit digital path i.e. the signal from the DFXS to the DFXO is muted	
Mute RX	Mutes the receive digital path i.e. the signal from the DFXO to the DFXS is muted	

3. Set the DFXS Input Level and the Output Level required:

Signal Direction	Level adjustment range	Default setting
Input Level (L_i)	-9.0 dBr to +3.0 dBr in 0.5 dB steps	+1.0 dBr
Output Level (L_o)	-9.5 dBr to +2.5 dBr in 0.5 dB steps	-6.0 dBr

In the example shown below, the Customer Premises Equipment is a telephone connected to a DFXS card.

The levels are set based on the system using a 0 dBr transmission reference point.

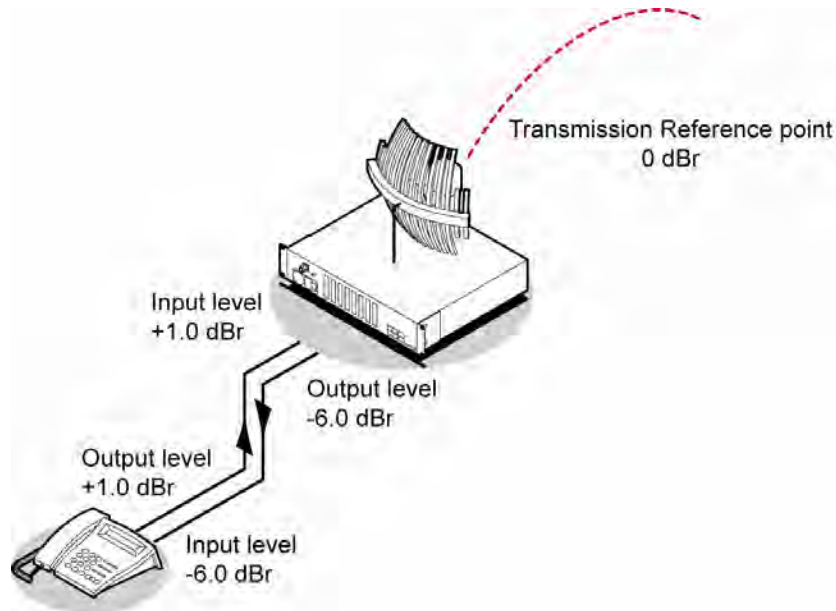

DFXS Input Level setting

The telephone has a nominal output level of +1 dBr. To achieve a transmission reference point transmit level of 0 dBr, the DFXS Input Level is set to +1 dBr (effective T pad loss of 1 dB).

DFXS Output Level setting

The telephone has a nominal input level of -6 dBr. With a transmission reference point received level of 0 dBr, the DFXS Output level is set to -6 dBr (effective R pad loss of 6 dB).

4. Click Apply to apply changes or Reset to restore the previous configuration.

5. Select the DFXS Control.

The DFXS Control page sets values for both ports on the DFXS card. The cards are shipped with the default values shown in the illustration below:

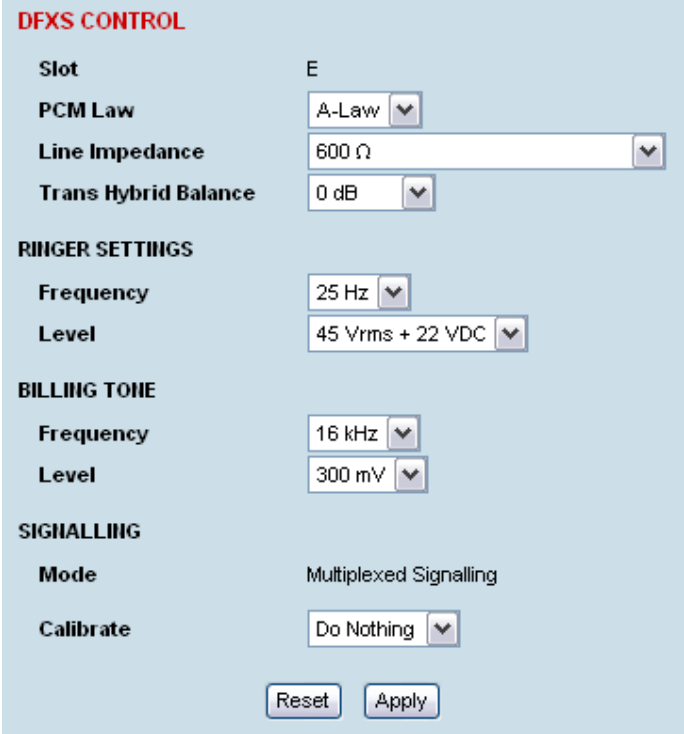

DFXS CONTROL

Slot E

PCM Law A-Law

Line Impedance 600 Ω

Trans Hybrid Balance 0 dB

RINGER SETTINGS

Frequency 25 Hz

Level 45 Vrms + 22 VDC

BILLING TONE

Frequency 16 kHz

Level 300 mV

SIGNALLING

Mode Multiplexed Signalling

Calibrate Do Nothing

Reset Apply

'Slot' shows the slot the DFXS interface card is plugged into in the terminal (A - H).

6. Select the DFXS PCM Law.

This option sets the companding law used by both ports on the DFXS card.

- A-Law is used internationally (default)
- μ -Law is used in North America and Japan.

Note: To run a mixture of μ -Law and A-Law interfaces, multiple DFXS cards are necessary.

7. Select the DFXS Line Impedance

This option sets the DFXS line termination impedance and the hybrid balance impedance to the same value.

Selection	Description	
600 Ω	Standard equipment impedance	Default
600 Ω + 2.16 μ F	Standard equipment impedance with low frequency roll-off	
900 Ω	Typically used on loaded cable pairs	
900 Ω + 2.16 μ F	Typically used on loaded cable pairs with low frequency roll-off	
TN12	Standard complex impedance for Australia	
TBR21	Widely deployed complex impedance	
BT3	Standard complex impedance for New Zealand	

- On a short line (< 100 meters), the selected impedance should match the impedance of the phone (off-hook).
- On a long line (> 1000 meters), the selected impedance should match the impedance of the phone (off-hook) as seen through the line.

If you are not sure what the expected impedance value should be, check with the CPE equipment supplier.

8. Set the DFXS Transhybrid Balance (usually not required to change).

The default Transhybrid Balance value (0 dB), provides the best circuit performance where the balance impedance (set by the Line Impedance setting) matches the impedance of the line.

You should only adjust the transhybrid balance when the balance impedance does not match the actual line impedance. You can achieve small circuit improvements using this option.

9. Set the DFXS Ringer Frequency.

This option sets the DFXS Ringing Frequency.

Selection	Description	
17 Hz	Used in older networks	
25 Hz	Standard ringing frequency	Default
50 Hz	Used by some telephone exchanges	

10. Set the DFXS Ringer Output Voltage.

This option sets the DFXS open circuit Ringing Output Voltage which is sourced via an internal ringing resistance of 178 Ω per port.

The DC offset on the AC ringing signal enables ring trip to occur with a DC loop either during ringing cycles. The normal DC line feed voltage enables ring trip to occur with a DC loop in the silent period between the ringing cycles.

Selection	Description	
60 Vrms + 0 VDC	Outputs 60 VRMS ringing with no DC offset Maximum ringing voltage for high ringing load applications but no DC ring trip	
55 Vrms + 10 VDC	Outputs 55 VRMS ringing with a 10 VDC offset Medium ringing load applications	
50 Vrms + 18 VDC	Outputs 50 VRMS ringing with a 18 VDC offset Above average ringing load applications	
45 Vrms + 22 VDC	Outputs 45 VRMS ringing with a 22 VDC offset Typical application	Default
40 Vrms + 24 VDC	Outputs 40 VRMS ringing with a 24 VDC offset Lowest terminal power consumption	

11. Select the DFXS Billing Tone Frequency.

This option sets the frequency of billing tone generation. If you are not sure what the expected frequency of the billing tone should be, check with the exchange equipment supplier.

Selection	Description	
12 kHz	Use if the CPE requires a 12 kHz billing tone signal	
16 kHz	Use if the CPE requires a 16 kHz billing tone signal	Default

12. Select the DFXS Billing Tone Level.

This option sets the DFXS billing tone output level which is defined as the voltage into 200 Ω with a source impedance equal to the Line Impedance setting.

The billing tone voltage into 200 Ω is limited by the maximum open circuit voltage of 1 Vrms. The drop down list reflects the maximum allowable billing tone output voltage for the Line Impedance setting selected.

Selection	Description	
400 mV rms	Billing tone voltage setting available for line impedances of TN12, BT3 and TBR21.	
300 mV rms	Billing tone voltage setting available for line impedances of TN12, BT3, TBR21 and 600 Ω .	Default
200 mV rms	Billing tone voltage setting available for line impedances of TN12, BT3, TBR21, 600 Ω and 900 Ω .	
100 mV rms	Billing tone voltage setting available for all line impedance settings.	

13. The DFXS billing tone Attack Ramp time can be adjusted to reduce the interference which can be produced when a signal turns on quickly. The attack ramp time is how long the billing tone generator takes to ramp up to full level when it is turned. The default ramp time is 1 ms.

DFXS BILLING TONE ADVANCED

Attack Ramp 1 ms

14. The DFXS Signalling Advanced options are used to control the four CAS bits ABCD in the DFXO to DFXS direction of transmission and one CAS bit A in the DFXS to DFXO direction of transmission. This option sets the signalling for both DFXS card ports.

Transparent Normal mode is used for normal traffic and Transparent Inverted mode can be used for special signalling requirements when a function needs to be reversed e.g. to change the idle polarity of the DFXS line feed voltage.

Forced modes are used to disable particular functions e.g. when polarity reversals are not required. They can also be used for system testing e.g. to apply DFXS continuous ringing output

DFXS SIGNALLING ADVANCED

TO DFXS

A Bit (fault / ring) Transparent Normal ▼

B Bit (ring / na) Transparent Normal ▼

C Bit (billing / na) Transparent Normal ▼

D Bit (reversal / na) Transparent Normal ▼

FROM DFXS

A Bit (off hook) Transparent Normal ▼

Selection	Description	
Transparent Normal	Normal transparent transmission of the CAS bit	Default
Transparent Inverted	Transparent transmission of the CAS bit but inverts the polarity.	
Forced Normal	Sets the CAS bit to 1 (inactive).	
Forced Inverted	Sets the CAS bit to 0 (active).	

DFXO to DFXS

CAS Bit	Forced Normal	Forced Inverted
A bit (fault)	Sets the CAS A bit to 1 continuous fault state	Sets the CAS A bit to 0 no fault state
B bit (ring)	Sets the CAS B bit to 1 no DFXS ringing output.	Sets the CAS B bit to 0 continuous DFXS ringing output.
C bit (billing)	Sets the CAS C bit to 1 no DFXS billing tone output.	Sets the CAS C bit to 0 continuous DFXS billing tone output.
D bit (reversal)	Sets the CAS D bit to 1 no DFXS polarity reversal	Sets the CAS D bit to 0 continuous DFXS polarity reversal

From DFXS to DFXO

CAS Bit	Forced Normal	Forced Inverted
A bit (off hook)	Sets the CAS A bit to 1 no DFXO off hook	Sets the CAS A bit to 0 continuous DFXO off hook

QJET to DFXS

CAS Bit	Forced Normal	Forced Inverted
A bit (ring)	Sets the CAS A bit to 1 no DFXS ringing output.	Sets the CAS A bit to 0 continuous DFXS ringing output.
B bit (na)	Not Applicable	Not Applicable
C bit (na)	Not Applicable	Not Applicable
D bit (na)	Not Applicable	Not Applicable

From DFXS to QJET

CAS Bit	Forced Normal	Forced Inverted
A bit (off hook)	Sets the CAS A bit to 1 Idle state to E1 port	Sets the CAS A bit to 0 Off hook state to E1 port

15. Click Apply to apply changes or Reset to restore the previous configuration.

DFXO Port Settings

1. Select Link or Local or Remote > Interface > Interface Summary, then select the DFXO interface and click Configure Interface.

DFXO INTERFACE PORTS SUMMARY

Slot	Port	PCM Mode	Input Level (dBr)	Output Level (dBr)	Loopback	Select
E	1	64 kbps PCM	-4.0	-1.0	Off	<input checked="" type="radio"/>
E	2	64 kbps PCM	-4.0	-1.0	Off	<input type="radio"/>

[Edit...](#)

2. Select the DFXO port to configure, and click Edit.

DFXO PORT SETTINGS

Slot E
Port 1
PCM Mode 64 kbps PCM
Input Level (dBr) -4.0
Output Level (dBr) -1.0
Loopback

[Reset](#) [Apply](#)

'Slot' shows the slot the DFXO interface card is plugged into in the terminal (A - H).

'Port' shows the interface port number (1-2).

'PCM Mode' shows the current mode assigned to the port by the cross connect.

'Loopback' loops back the port digital paths to return the port analogue signal back to the customer.

3. Set the DFXO Input Level and the Output Level required:

Signal Direction	Level adjustment range	Default setting
Input Level (L_i)	-10.0 dBr to +1.0 dBr in 0.5 dB steps	-4.0 dBr
Output Level (L_o)	-10.0 dBr to +1.0 dBr in 0.5 dB steps	-1.0 dBr

In the example shown below, the PSTN exchange line card is connected to a DFXO card. The levels are set based on the system using a 0 dBr transmission reference point.

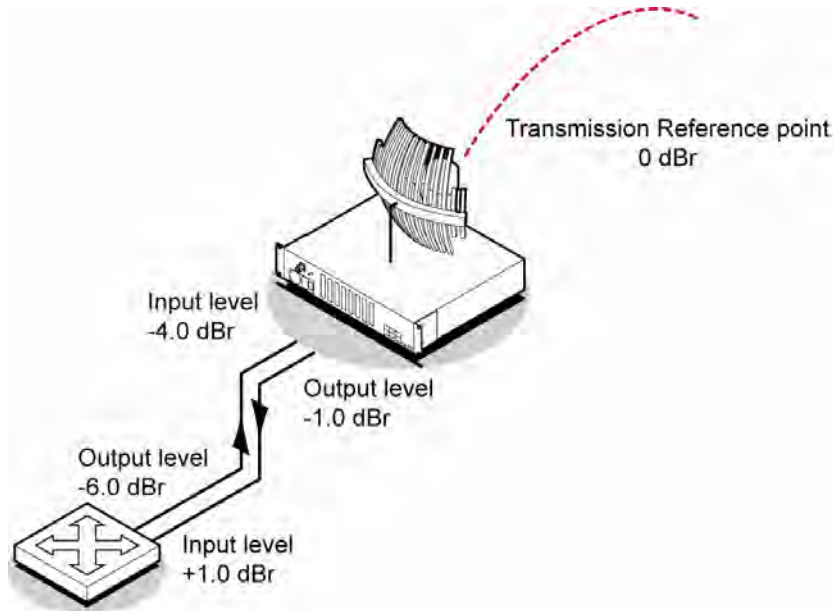

DFXO Input Level setting

The exchange line card has a nominal output level of -6 dBr. To achieve a digital reference point transmit level of -2.0 dBm0, the DFXO input level is set to -4.0 dBr (effective T pad gain of 4.0 dB).

The deliberate 2 dB of loss between the exchange line card and the DFXO provides a 2 dB of overall circuit loss between the DFXO and the DFXS.

DFXO Output Level setting

The exchange line card has a nominal input level of +1.0 dBr. With a transmission reference point received level of -2.0 dBm0, the DFXO output level is set to -1.0 dBr (effective R pad loss of 1.0 dB).

The deliberate 2 dB of loss between the exchange line card and the DFXO provides a 2 dB of overall circuit loss between the DFXS and the DFXO.

4. Click Apply to apply changes or Reset to restore the previous configuration.

5. Select the DFXO Control.

The DFXO Control page sets values for both ports on the DFXO card. The cards are shipped with the default values shown in the illustration below:

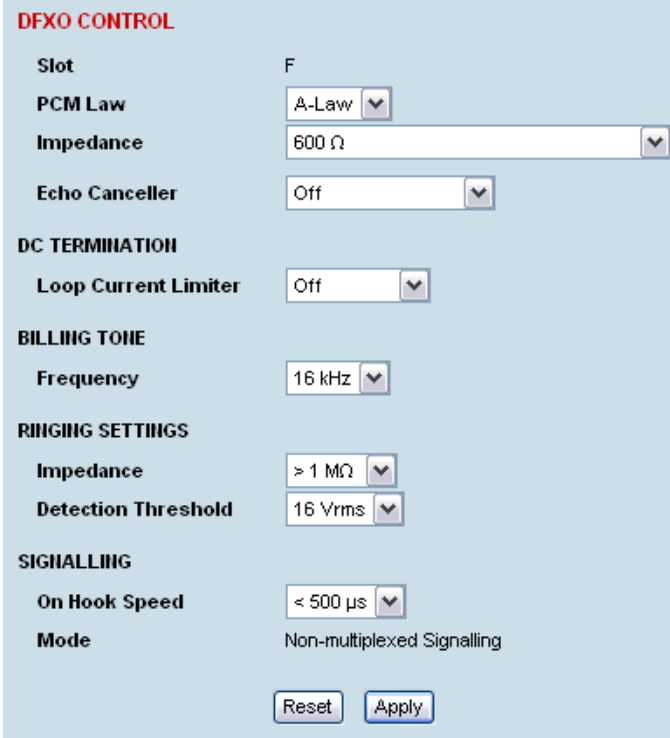

DFXO CONTROL

Slot: F

PCM Law: A-Law

Impedance: 600 Ω

Echo Cancellor: Off

DC TERMINATION

Loop Current Limiter: Off

BILLING TONE

Frequency: 16 kHz

RINGING SETTINGS

Impedance: > 1 MΩ

Detection Threshold: 16 Vrms

SIGNALLING

On Hook Speed: < 500 μs

Mode: Non-multiplexed Signalling

Reset Apply

'Slot' shows the slot the DFXO interface card is plugged into in the terminal (A - H).

6. Select the DFXO PCM Law.

This option sets the companding law used by both ports on the DFXO card.

- A-Law is used internationally (default)
- μ-Law is used in North America and Japan.

Note: To run a mixture of μ-Law and A-Law interfaces, multiple DFXO cards are necessary.

7. Select the DFXO Impedance

This option sets the DFXO line termination impedance and the hybrid balance impedance to the same value.

Selection	Description	
600 Ω	Standard equipment impedance	Default
600 Ω + 2.16 μ F	Standard equipment impedance with low frequency roll-off	
900 Ω	Typically used on loaded cable pairs	
900 Ω + 2.16 μ F	Typically used on loaded cable pairs with low frequency roll-off	
TN12	Standard complex impedance for Australia	
TBR21	Widely deployed complex impedance	
BT3	Standard complex impedance for New Zealand	
BT Network	Standard complex impedance for UK	
China	Standard complex impedance for China	

- On a short line (< 100 metres), the selected impedance should match the impedance of the exchange line card.
- On a long line (> 1000 metres), the selected impedance should match the impedance of the exchange line card as seen through the line.

If you are not sure what the expected impedance value should be, check with the exchange equipment supplier.

8. Enable the DFXO Echo Canceller if required.

The DFXO Echo Canceller provides up to 64 ms of echo cancellation. This feature is only available on Rev D (and later) DFXO cards.

Analogue data devices e.g. modems send a disable signal to disable any echo canceller in circuit while it trains its own echo canceller. There are two possible disable signals. ITU G.164 specifies a disable signal of a single 2100 Hz tone and ITU G.165 specifies a disable signal of 2100 Hz tone with phase reversals every 450 ms.

Selection	Description	
Off	No echo canceller operation.	Default
On	Echo canceller operational but without disabling.	
Auto Disable G.164	Echo canceller operational with automatic disabling using ITU G.164 2100 Hz tone.	
Auto Disable G.165	Echo canceller operational with automatic disabling using ITU G.165 2100 Hz tone with phase reversals every 450 ms.	

9. Set the DFXO Loop Current Limiter.

This option turns on a current limiter which limits the maximum current that can be drawn from the exchange line card by the DFXO interface.

As a general rule, only one interface should current limit so if the exchange interface current limits, the DFXO interface should be set to current limit off.

Selection	Description	
Off	Use if the exchange line interface uses current limiting.	Default
On (60 mA)	Use if the exchange line interface does not use current limiting. The DFXO limits the line loop current to 60 mA.	

Note: The DFXO provides an early warning over current alarm ‘fxoCurrentOvld’ if the loop current exceeds 100 mA for 2 seconds. This alarm clears when the loop current is less than 90 mA.

The DFXO also provides an over current safety shut down limit which removes its line loop if the loop current exceeds 160 mA.

10. Select the DFXO Billing Tone Frequency.

This option sets the frequency of billing tone detection. If you are not sure what the expected frequency of the billing tone should be, check with the exchange equipment supplier.

Selection	Description	
12 kHz	Use if the exchange outputs 12 kHz billing tone	
16 kHz	Use if the exchange outputs 16 kHz billing tone	Default

11. The DFXO Billing Tone Advanced sets the billing tone Bandwidth and the billing tone Level Sensitivity.

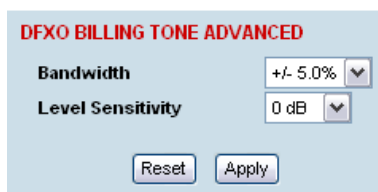

The DFXO billing tone Bandwidth determines the bandwidth of the band pass filter that is used by the billing tone detector in terms of +/- % of the billing tone frequency.

The adjustment range is +/- 1.5% to +/- 7.5% and the default value is +/- 5.0%.

The DFXO billing tone Level Sensitivity determines the DFXO detection sensitivity.

The adjustment range is 0 dB (metering detection threshold of -17 dBm measured across 200 Ω) to 27 dB (metering detection threshold of -40 dBm measured across 200 Ω) in 1 dB steps and the default value is 0 dB.

12. Select the DFXO On Hook Speed.

This option sets the slope of the transition between off-hook and on-hook.

Selection	Description	
< 500 μ s	Off-hook to on-hook slope of < 500 μ s	Default
3 ms	Off-hook to on-hook slope of 3 ms \pm 10% that meets ETSI standard	
25 ms	Off-hook to on-hook slope of 25 ms \pm 10% used to reduce transient interference in copper cable	

13. Select the DFXO ringer Impedance.

This option sets the DFXO ringing input impedance as seen by a sine wave ringing signal applied to the DFXO 2 wire port at the frequency of ringing.

Selection	Description	
> 1 M Ω	DFXO input impedance to ringing of > 1 M Ω	Default
> 12 k Ω	DFXO input impedance to ringing of > 12 k Ω	

14. Select the DFXO ringer Detection Threshold.

This option sets the DFXO ringing detect threshold.

Selection	Description	
16 Vrms	DFXO detects ringing voltages of 16 Vrms or greater (does not detect ringing below 13 Vrms)	Default
26 Vrms	DFXO detects ringing voltages of 26 Vrms or greater (does not detect ringing below 19 Vrms)	
49 Vrms	DFXO detects ringing voltages of 49 Vrms or greater (does not detect ringing below 40 Vrms)	

It is recommended that the ringer Detection Threshold be set to 49 Vrms if a DFXO ringer impedance of > 12 k Ω is selected.

Note: The Signalling Mode is set in the Cross Connections application (see page 171).

15. The DFXO Signalling Advanced options are used to control the four CAS bits ABCD in the DFXO to DFXS direction of transmission and one CAS bit A in the DFXS to DFXO direction of transmission. This option sets the signalling for both DFXO card ports.

Transparent Normal mode is used for normal traffic and Transparent Inverted mode can be used for special signalling requirements when a function needs to be reversed e.g. to change the idle polarity of the DFXS line feed voltage.

Forced modes are used to disable particular functions e.g. when polarity reversals are not required. They can also be used for system testing e.g. to apply DFXO continuous off hook

DFXO SIGNALLING ADVANCED

FROM DFXO

A Bit (fault / ring) Transparent Normal ▼

B Bit (ring / na) Transparent Normal ▼

C Bit (billing / na) Transparent Normal ▼

D Bit (reversal / na) Transparent Normal ▼

TO DFXO

A Bit (off hook) Transparent Normal ▼

Selection	Description	
Transparent Normal	Normal transparent transmission of the CAS bit	Default
Transparent Inverted	Transparent transmission of the CAS bit but inverts the polarity.	
Forced Normal	Sets the CAS bit to 1.	
Forced Inverted	Sets the CAS bit to 0.	

From DFXO to DFXS

CAS Bit	Forced Normal	Forced Inverted
A bit (fault)	Sets the CAS A bit to 1 continuous fault state	Sets the CAS A bit to 0 no fault state
B bit (ring)	Sets the CAS B bit to 1 no DFXS ringing output.	Sets the CAS B bit to 0 continuous DFXS ringing output.
C bit (billing)	Sets the CAS C bit to 1 no DFXS billing tone output.	Sets the CAS C bit to 0 continuous DFXS billing tone output.
D bit (reversal)	Sets the CAS D bit to 1 no DFXS polarity reversal	Sets the CAS D bit to 0 continuous DFXS polarity reversal

DFXS to DFXO

CAS Bit	Forced Normal	Forced Inverted
A bit (off hook)	Sets the CAS A bit to 1 no DFXO off hook	Sets the CAS A bit to 0 continuous DFXO off hook

QJET to DFXS

CAS Bit	Forced Normal	Forced Inverted
A bit (ring)	Sets the CAS A bit to 1 no DFXS ringing output.	Sets the CAS A bit to 0 continuous DFXS ringing output.
B bit (na)	Not Applicable	Not Applicable
C bit (na)	Not Applicable	Not Applicable
D bit (na)	Not Applicable	Not Applicable

From DFXS to QJET

CAS Bit	Forced Normal	Forced Inverted
A bit (off hook)	Sets the CAS A bit to 1 Idle state to E1 port	Sets the CAS A bit to 0 Off hook state to E1 port

16. Click Apply to apply changes or Reset to restore the previous configuration.

QV24 Serial Interface Card

There are two modes of operation of the QV24 Serial Interface Card; QV24 asynchronous and QV24S synchronous. The mode is changed with the Slot Summary.

Changing the QV24 mode changes all four ports on the interface card.

To change the QV24 mode:

1. Select Link or Local or Remote > Interface > Slot Summary, then select the QV24 interface slot and click Configure Slot.

SLOT SUMMARY						
Slot	Installed	Expected	HSC	H/W Rev	Serial Number	Select
A	None	None	0	00	"	<input checked="" type="radio"/>
B	None	None	0	00	"	<input type="radio"/>
C	Q4EM	Q4EM	1	B	33102489	<input type="radio"/>
D	QJET	QJET	0	C	33102450	<input type="radio"/>
E	DFXO	DFXO	1	B	33103430	<input type="radio"/>
F	QV24	QV24	0	A	33117353	<input type="radio"/>
G	QV24	QV24	0	A	33103461	<input type="radio"/>
H	HSS	HSS	0	A	33103755	<input type="radio"/>
Aux	Modem	Modem	0	A	33102566	<input type="radio"/>

[Configure Slot...](#)

2. Select the QV24 mode required with Expected.

EDIT INTERFACE SLOT

Slot: F

HSC: 0

H/W Rev: A

Installed: QV24

Expected: QV24S ▼

Change Type To: QV24S ▼

3. Select the QV24 mode required with Change Type To and click Apply.
4. Reboot the terminal with a Hard Reboot (see 'Rebooting the Terminal' on page 233).

QV24 Port Settings

A QV24 interface is always configured as a DCE.

1. Select Link or Local or Remote > Interface > Interface Summary, then select the QV24 interface and click Configure Interface.

Slot	Port	Baud Rate	Loopback	Select
G	1	9600	Off	<input checked="" type="radio"/>
G	2	19200	Off	<input type="radio"/>
G	3	38400	Off	<input type="radio"/>
G	4	300	Off	<input type="radio"/>

[Edit...](#)

2. Select the QV24 port to configure, and click Edit.

QV24 PORT CONTROL

Slot G
Port 1
Baud Rate 9600
Data Bits 8
Stop Bits 1
Parity Bits 0
Loopback Off On

[Reset](#) [Apply](#)

'Slot' shows the slot the QV24 interface card is plugged into in the terminal.

'Port' shows the interface port number (1-4).

'Baud Rate' shows the current baud rate assigned to the port by the cross connect.

'Loopback' loops back the port data to the customer (default is no loopback).

3. Set the number of Data Bits (default is 8 bits).
4. Set the number of Stop Bits (default is 1 bit).
5. Set the number of Parity Bits (default is 0 bits).
6. Click Apply to apply changes or Reset to restore the previous configuration.

Tip: The Quick Links box provides links to other related pages.

QV24S Port Settings

There are two modes of operation of the QV24S synchronous, synchronous and over sampling modes. A QV24S interface is always configured as a DCE.

Synchronous Mode

In synchronous mode, interface data is synchronously mapped to radio capacity using proprietary subrate multiplexing. QV24S interfaces are required at both ends of the circuit.

1. Select Link or Local or Remote > Interface > Interface Summary, then select the QV24S interface and click Configure Interface.

QV24S PORT SUMMARY				
Slot	Port	Baud Rate	Loopback	Select
G	1	300	Off	<input checked="" type="radio"/>
G	2	1200	Off	<input type="radio"/>
G	3	4800	Off	<input type="radio"/>
G	4	9600	Off	<input type="radio"/>

[Edit...](#)

2. Select the QV24S port to configure, and click Edit.

QV24S PORT CONTROL	
Slot	B
Port	2
Baud Rate	19200
CTS Source	Remote RTS <input type="button" value="v"/>
Sample Data On	Falling Clock Edge <input type="button" value="v"/>
Loopback	Off <input type="button" value="v"/>
<input type="button" value="Reset"/> <input type="button" value="Apply"/>	

'Slot' shows the slot the QV24S interface card is plugged into in the terminal.

'Port' shows the interface port number (1-4).

'Baud Rate' shows the current baud rate assigned to the port by the cross connect.

3. The CTS Source defines the mode in which the CTS signal responds to the remote DTE. Three options are available:

CTS Source	Function
Remote RTS	The local CTS follows the remote RTS signal. In the case of radio link failure (when cross connected over the link) the signal goes to OFF.
Local RTS	The local CTS signal follows the local RTS. The status of the link does not impact on the CTS signal.
On Permanent	The local CTS is in a permanent ON (+ve) state. This does not go to OFF if the link fails.

Note that the CTS behaviour is not impacted by the operation of the card loopbacks.

4. The Sample Data On defines the received clock edge on which the received data is clocked into the port. Two options are available:

Sample Data On	Function
Falling Clock Edge	The falling edge of the XTXC is used to clock data into the port.
Rising Clock Edge	The rising edge of the XTXC is used to clock data into the port.

5. 'Loopback' loops back the port data to the customer (default is no loopback).
6. Click Apply to apply changes or Reset to restore the previous configuration.

Over Sampling Mode

In over sampling mode, 64 kbit/s of radio capacity is allocated to the circuit and the incoming interface data is sampled at a fixed 64 kHz. This timeslot can be cross connected to an E1 or T1. This over sampling mode can be operated up to 19.2 kbit/s.

There will be some unavoidable distortion in mark space ratios (jitter) of the transported V.24 circuit. This effect will become progressively more significant as the baud rate of the V.24 circuit increases or the number of data conversions increases.

In over sampling mode, the DTE clock input is not used and there is no DCE output clock available.

1. Select Link or Local or Remote > Interface > Interface Summary, then select the QV24S interface and click Configure Interface.

QV24S PORT SUMMARY				
Slot	Port	Baud Rate	Loopback	Select
B	1	OVRAMP	Off	<input checked="" type="radio"/>
B	2	19200	Off	<input type="radio"/>
B	3	19200	Off	<input type="radio"/>
B	4	19200	Off	<input type="radio"/>

[Edit...](#)

- Select the QV24S port to configure, and click Edit.

QV24S PORT CONTROL

Slot B

Port 1

Baud Rate OVRSAMP

CTS Source

Sample Data On

Loopback

'Slot' shows the slot the QV24S interface card is plugged into in the terminal.

'Port' shows the interface port number (1-4).

A Baud Rate of 'OVRSAMP' indicates that the QV24S has been configured for synchronous over sampling mode in the Cross Connections application.

- The CTS Source defines the mode in which the CTS signal responds to the remote DTE. Two options are available:

CTS Source	Function
Local RTS	The local CTS signal follows the local RTS. The status of the link does not impact on the CTS signal.
On Permanent	The local CTS is in a permanent ON (+ve) state. This does not go to OFF if the link fails.

Note that the CTS behaviour is not impacted by the operation of the card loopbacks.

- The Sample Data On defines the received clock edge on which the received data is clocked into the port. Two options are available:

Sample Data On	Function
Falling Clock Edge	The falling edge of the XTXC is used to clock data into the port.
Rising Clock Edge	The rising edge of the XTXC is used to clock data into the port.

- 'Loopback' loops back the port data to the customer (default is no loopback).
- Click Apply to apply changes or Reset to restore the previous configuration.

HSS Port Settings

1. Select Link or Local or Remote > Interface > Interface Summary, then select HSS (High-speed Synchronous Serial) interface and click Configure Interface.

'Slot' shows the slot the HSS interface card is plugged into in the terminal (A - H).

'Mode' shows the interface mode provided by the HSS interface (either DTE or DCE). If there is no interface cable plugged into the HSS port, the 'Mode' will show 'No Cable'.

'Serial Mode' shows interface type provided by the HSS interface (X.21, V.35 etc). If there is no interface cable plugged into the HSS port, the 'Serial Mode' will show 'None'.

'Baud Rate (kbit/s)' shows the current baud rate assigned to the port by the cross connect.

'Loopback' loops back the port data to the customer (default is no loopback).

'Synchronous Clock Selection' shows the current clocking mode assigned to the port by the cross connect.

2. Set the HSS RTS CTS Mode as required.

The RTS CTS mode controls the state of the outgoing interface RTS CTS control line.

When the HSS interface is DCE, the outgoing control line is CTS. When the HSS interface is DTE, the outgoing control line is RTS.

Note: Refer to 'HSS Handshaking and Clocking' on page 135 for additional information on setting the recommended handshaking mode for each application.

3. Set the HSS DSR DTR Mode as required.

The DSR DTR mode controls the state of the outgoing interface DSR DTR control line.

When the HSS interface is DCE, the outgoing control line is DSR. When the HSS interface is DTE, the outgoing control line is DTR.

4. Set the HSS DCD Mode as required.

The DCD mode controls the state of the outgoing interface DCD control line.

This setting is only relevant if the HSS interface is DCE.

5. Enable or disable the HSS XTxC control, as required.

Depending on the clocking mode (see 'HSS Handshaking and Clocking' on page 135) selected, altering this setting will allow the terminal clock to be substituted for the external XTxC signal.

6. Click Apply to apply changes or Reset to restore the previous configuration.

HSS Handshaking and Clocking Modes

This section provides detailed information on selecting the recommended HSS handshaking and clocking modes for the HSS interface card (see 'HSS port settings' on page 133).

HSS Handshaking and Control Line Function

HSS X.21 Compatibility

In general X.21 usage, the C and I wires function as handshaking lines analogous to RTS/CTS handshakes. For switched carrier applications, the I wire is used to emulate carrier indications (DCD) function.

HSS RTS / CTS Mode

Set the RTS CTS Mode as required according to the table below. This field controls the state of the outgoing interface control line.

- When the HSS interface is DCE, the outgoing control line is CTS.
- When the HSS interface is DTE, the outgoing control line is RTS.

RTS CTS Mode	HSS as a DCE	HSS as a DTE	Comment
Always Off	CTS driven to off state	RTS driven to off state	
Always On	CTS driven to on state	RTS driven to on state	
Follows Carrier	CTS follows the state of the RF link	RTS follows the state of the RF link	To follow carrier is to indicate the state of synchronization of the RF link
Follows Carrier + Remote RTS/CTS	CTS follows the state of the RF link and the remote terminal RTS input control line if the remote is a DCE. If the remote HSS is a DTE, then CTS follows the state of the RF link and the remote HSS CTS input.	RTS follows the state of the RF link and the remote terminal RTS input control line. The remote HSS can only be a DCE.	Control line pass-through mode where RTS and CTS are carried over the link from end to end. The carrier (as above) plus the remote terminal input control line must be present to output the local control line signal. The HSS Control bit in the Cross Connections application must be set for the remote signalling to operate.
Follows Carrier + Remote DCD	CTS follows the state of the RF link if the remote HSS is a DCE. If the remote HSS is a DTE, then CTS follows the state of the RF link and the remote HSS DCD input control line.		This setting is only applicable when the local HSS card in the local terminal is a DCE. The HSS Control bit in the Cross Connections application must be set for the remote signalling to operate.

HSS DSR / DTR Mode

Set the DSR DTR Mode as required according to the table below. This field controls the state of the outgoing interface control line.

- When the HSS interface is DCE, the outgoing control line is DSR
- When the HSS interface is DTE, the outgoing control line is DTR

DSR DTR Mode	HSS as a DCE	HSS as a DTE	Comment
Always Off	DSR driven to off state	DTR driven to off state	
Always On	DSR driven to on state	DTR driven to on state	
Follows Carrier	DSR follows the state of the RF link	DTR follows the state of the RF link	To follow carrier is to indicate the state of synchronization of the RF link.
Follows Carrier + Remote DSR/DTR	DSR follows the state of the RF link and the remote terminal DSR control line if the remote terminal is a DTE, or the remote DTR if the remote terminal is a DCE.	DTR follows the state of the RF link and the remote terminal DTR control line if the remote terminal is a DCE. The remote HSS can only be a DCE.	Control line pass-through mode where DSR and DTR are carried over the link from end to end. The carrier (as above) plus the remote terminal input control line must be present to output the local control line signal. The HSS Control bit in the Cross Connections application must be set for the remote signalling to operate.

HSS DCD Mode

Set the DCD Mode as required according to the table below. This setting is only relevant in DCE mode.

DCD Mode	HSS as a DCE	HSS as a DTE	Comment
Always Off	DCD driven to off state	NOT applicable	
Always On	DCD driven to on state		
Follows Carrier + Remote DCD	DCD follows the state of the RF link and the remote terminal DCD input control line if the remote HSS is a DTE. If the remote terminal is a DCE, then DCD only follows the state of the RF link.		Control line pass-through mode where DCD is carried over the link from end to end. The carrier (as above) plus the remote terminal input control line must be present to output the local control line signal. The HSS Control bit in the Cross Connections application must be set for the remote signalling to operate.
Follows Carrier + Remote RTS	DCD follows the state of the RF link and the remote terminal RTS input control line when the remote HSS is a DCE.		For switched carrier applications this provides RTS-DCD pass through (DCE to DCE configuration) and DCD-DCD pass-through (DTE to DCE configuration).

Set the XTxC Enabled control as required. Depending on the synchronous clock selection mode selected, disabling XTxC will allow the terminal clock to be substituted for the external XTxC signal.

HSS Synchronous Clock Selection Modes

The following section describes in detail each of the recommended HSS Synchronous Clock Selection modes for both DTE to DCE and DCE to DCE modes of operation.

The HSS clocking can be configured for clocking types of Internal clocking, pass-through clocking, and primary / secondary master clocking. The topology of the client network determines the clock mode that is used.

Note: Modes 3 and 4 provide only physical layer support, not X.21 protocol support.

Terminal 1 HSS as a DTE and terminal 2 HSS as a DCE - 'Pipe Mode'

Mode	Synchronous Clock Selection mode	Clocking Type
0	Internal Clocks - No overhead	Not supported
1	RxC + XTxC - 40 kbit/s overhead	Not supported
2	RxC + TxC - 56 kbit/s overhead	Pass-through clocking
3	RxC (X.21) - 40 kbit/s overhead	Pass-through clocking (X.21 only)
4	RxC (X.21) - No overhead	Not supported
5	XTxC → RxC - 40 kbit/s overhead	Not supported
6	RxC → RxC - No overhead	Primary/ Secondary Master clocking
7	RxC → RxC - 40 kbit/s overhead	Pass-through clocking

Terminal 1 HSS as a DCE and terminal 2 HSS as a DCE - 'Cloud Mode'

Mode	Synchronous Clock Selection mode	Clocking Type
0	Internal Clocks - No overhead	Internal clocking
1	RxC + XTxC- 40 kbit/s overhead	Not supported
2	RxC + TxC- 56 kbit/s overhead	Not supported
3	RxC (X.21) - 40 kbit/s overhead	Not supported
4	RxC (X.21) - No overhead	Internal clocking (X.21 only)
5	XTxC → RxC - 40 kbit/s overhead	Pass-through clocking
6	RxC → RxC - No overhead	Not supported
7	RxC → RxC - 40 kbit/s overhead	Not supported

HSS Clocking Types

HSS internal clocking

Internal clocking relies on the (highly accurate) terminal system clock, that is, it does not allow for any independent clocks coming in from client equipment.

For this mode, all incoming clocks must be slaved to a clock emanating from the HSS card.

HSS pass-through clocking

The HSS card is capable in hardware of passing two clocks from one side of a link to the other. Passing a clock means that the difference between the client clock(s) and the terminal clock is transferred across the link continuously. Passing a single clock in each direction requires 40 kbit/s additional link overhead, passing two clocks from DTE to DCE requires 56 kbit/s overhead, whereas relying on internal clocking requires no overhead.

Network topology determines if passing a clock makes sense. Passing a clock is used where a client's incoming clock must be kept independent of the clock sourced by the HSS card. The only time it makes sense to pass two clocks is when a client DCE in one of the HSS modes provides two independent clocks, that is, the HSS is set to Clock Mode 2.

Pass-through clocking does not require using the HSS incoming clock as a Primary or Secondary master clock for the link, but does not preclude it either.

HSS primary / secondary master clocking

When implementing an external clock master, all other interfaces in the terminal and internal system timings are slaved to this external clock. The remote terminal is also slaved to this master clock. This master clock must be within 100 ppm of the accuracy of the terminal system clock, otherwise the terminal will revert to using its internal clock. Ideally, the external clock should be much better than 100 ppm.

Mode 6 is offered for those network topologies that require RxC and TxC to be locked. For example, this is useful when interworking with an Aprisa SE HSS interface.

HSS Clcking DTE to DCE ‘Pipe Mode’

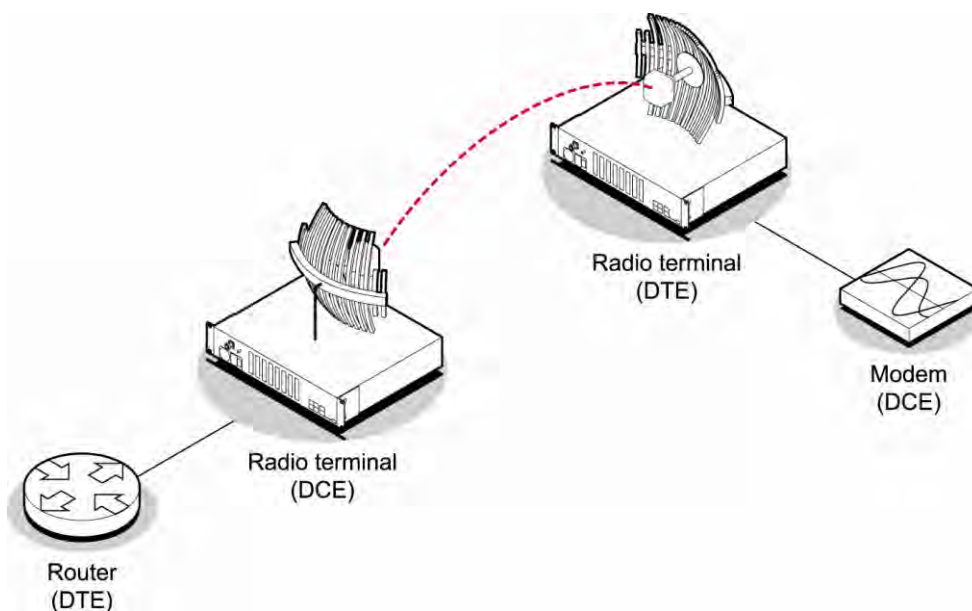

DTE to DCE Mode 2: <u>RxC + TxC - 56 kbit/s overhead</u> (Pass-through clocking)			
DTE clocks used	DCE clocks used	Clock passing	Comment
RxC and TxC	RxC and TxC	56 kbit/s of overhead is used to transport RxC and TxC from HSS DTE to HSS DCE.	<p>This is the preferred dual external clock system.</p> <p>Both clocks travel in the same direction from DTE to DCE. This mode is used when it is important that the externally supplied RxC and TxC are maintained independently.</p> <p>This is almost only required in cascaded (that is, multi-link) networks.</p> <p>This mode cannot be used in conjunction with any interface conversion to / from X.21.</p>

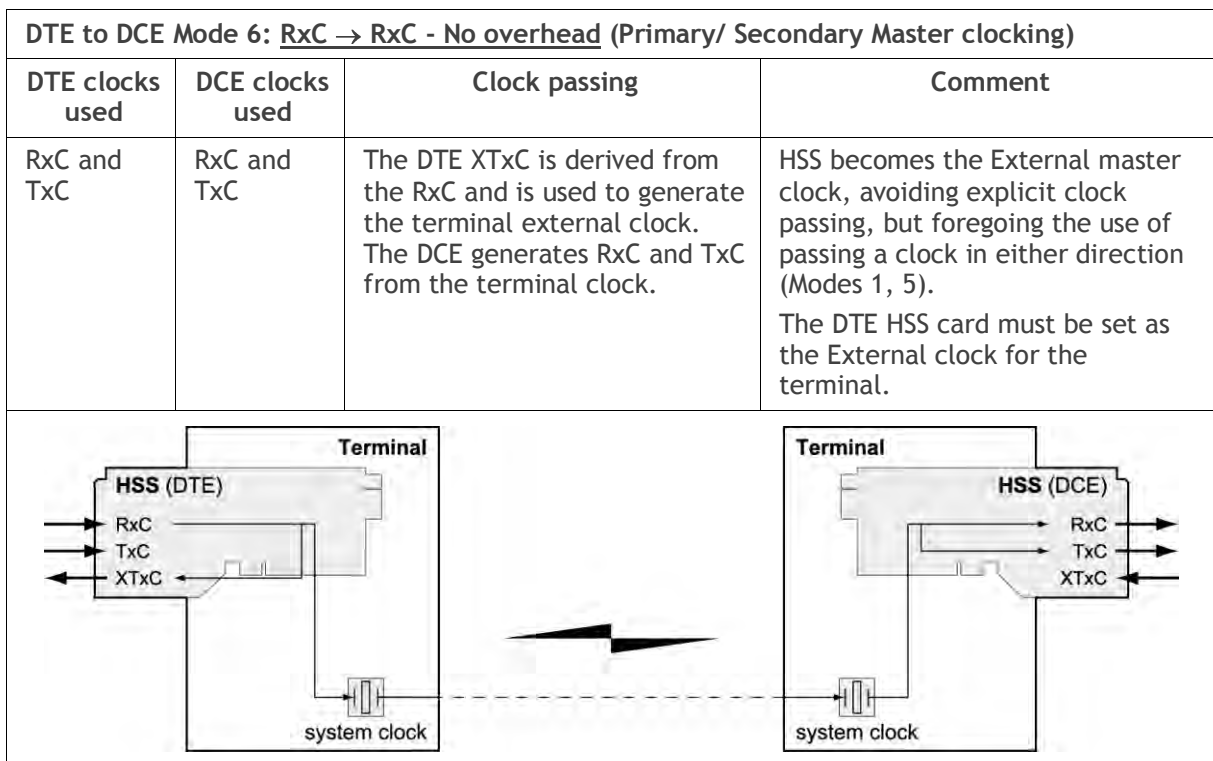
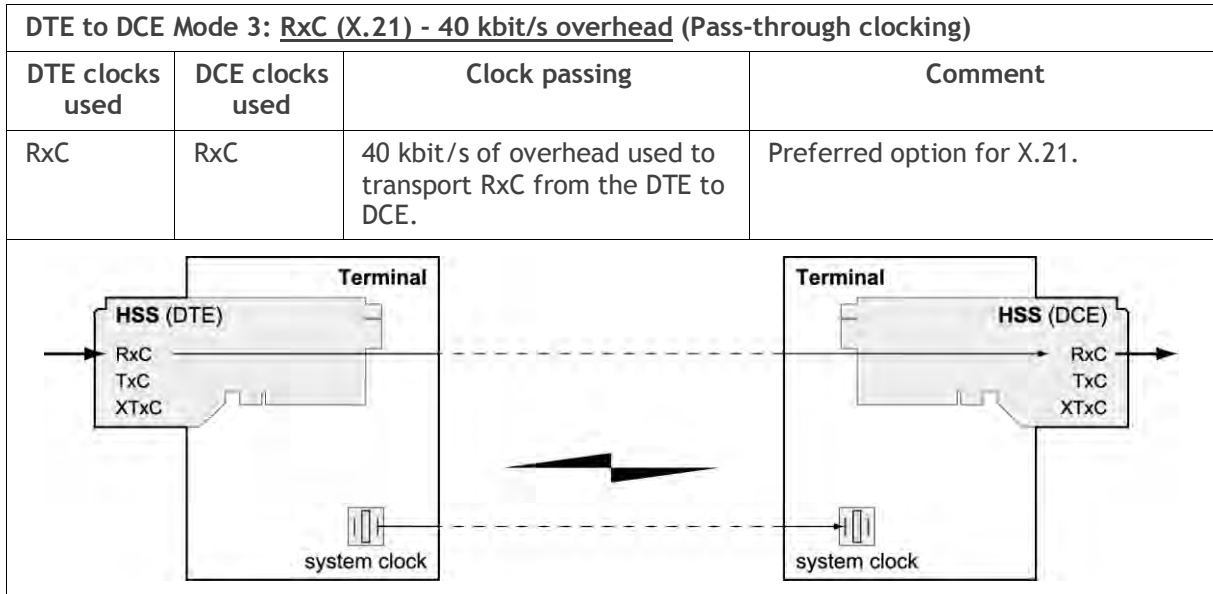

DTE to DCE Mode 7: <u>RxC → RxC - 40 kbit/s overhead</u> (Pass-through clocking)			
DTE clocks used	DCE clocks used	Clock passing	Comment
RxC and TxC	RxC and TxC	40 kbit/s of overhead used to transfer RxC from the DTE to the DCE RxC and TxC.	Receiver derived clock system.

The diagram illustrates the clocking configuration for DTE to DCE Mode 7. It shows two terminals: HSS (DTE) on the left and HSS (DCE) on the right. A lightning bolt symbol between them indicates a connection. The HSS (DTE) terminal has three signal lines: RxC (input), TxC (input), and XTxC (output). The HSS (DCE) terminal has three signal lines: RxC (output), TxC (output), and XTxC (input). Both terminals are connected to a 'system clock' block. Dashed lines show the RxC signal path from the DTE terminal to the DCE terminal, and the TxC signal path from the DTE terminal to the DCE terminal. The XTxC signal path is shown from the DTE terminal to the DCE terminal.

HSS Clocking DCE to DCE ‘Cloud Mode’

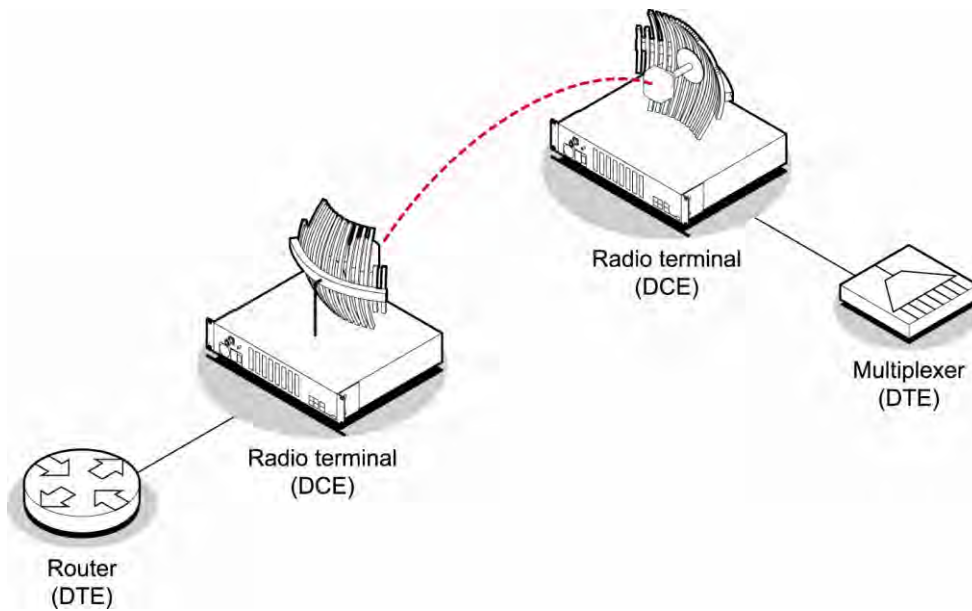

DCE to DCE Mode 0: <u>Internal clocks - No overhead</u> (internal clocking)		
DCE clocks used	Clock passing	Comment
RxC, TxC, XTxC	Both RxC and TxC are derived from the terminal clock.	Default setting. All clocks sourced internally. XTxC will be used if it is detected.

The diagram below the table shows two terminals connected by a system clock. Each terminal contains an HSS (DCE) block. The system clock provides RxC, TxC, and XTxC signals to the HSS (DCE) blocks in both terminals. The left terminal shows RxC and TxC as outputs and XTxC as an input. The right terminal shows RxC and TxC as outputs and XTxC as an input.

DCE to DCE Mode 4: <u>RxC (X.21) - No overhead</u> (internal clocking)		
DCE clocks used	Clock passing	Comment
RxC	RxC is derived from the terminal clock.	Suggested for X.21 Cloud Configuration. Single clock X.21 system.

DCE to DCE Mode 5: <u>XTxC → RxC</u> - 40 kbit/s overhead (Pass-through clocking)		
DCE clocks used	Clock passing	Comment
RxC, TxC, XTxC		XTxC is transported to RxC and TxC in both directions

10. Cross Connections

Embedded Cross Connect Switch

The embedded cross-connect switch distributes capacity to each of the interfaces.

Traffic can be distributed to any of the possible 32 interface ports as well as the integrated Ethernet interface. This provides the flexibility to reconfigure traffic as the network demand changes, or groom user traffic onto E1 / T1 bearers between equipment.

The maximum number of simultaneous cross connections per terminal is 256. During cross connection activation, a progress bar shows the number of ports that have activated.

Link Capacity Utilization

Cross connections are able to utilize all of the available capacity of the link on lower capacity radio links (< 2048 kbit/s gross capacity, i.e. up to 500 kHz, 16 QAM). However, as higher capacity radio links allocate bandwidth for E1 / T1 timeslot connections on 64 kbit/s boundaries, some capacity may be unusable (< 64 kbit/s).

The Cross Connections Application

The Cross Connections application is a software application that is used to:

- manage the cross connections switches within the terminals
- create cross connections between the traffic interface ports within one terminal or between the near end and far end terminals via the radio bearer
- create cross connections between symmetrical traffic interface ports with the symmetrical connection wizard
- get the current cross connection configuration from the terminal
- send and activate the cross connection configuration
- save and load configuration files

The Cross Connections System Requirements

The Cross Connections application requires the following minimum PC requirements:

- 1024 x 768 screen resolution
- Ethernet interface
- Java Virtual Machine

Installing the Cross Connections Application

The Cross Connections application is usually started directly from SuperVisor without the need for installation.

However, if you want to use the Cross Connections application offline (without any connection to the terminals), you can install it on your PC. Working offline enables you to simulate new cards or terminal capacities. The cross connections can then be configured and the resulting configuration file saved for later deployment.

To install the Cross Connections application on your PC, navigate to the Cross Connect directory on the supplied CD and copy the application (ccapp_exe_x_x_x.jar where x is the version) to a suitable place on your PC hard disk.

Your PC 'File Types' must associate a *.jar file with the Executable Jar File so that when the *.jar file is clicked on (or double clicked on), it will be executed with Javaw.exe. If clicking on (or double clicking on) the jar file does not bring up the Cross Connections application, the 'File Types' needs to be setup in your PC.

- Go to 'My Computer / Tools / Folder Options / File Types' and click 'New'.
- Type 'Jar' in the 'File Extension' box and click OK.
- Click 'Change' and 'Select a program from a list'
- Select 'Javaw.exe' and click OK.

Opening the Cross Connections Application

To open the Cross Connections application from within SuperVisor:

Select Link > Interface > Cross Connections

To open the Cross Connections application without SuperVisor:

Navigate to the installed cross connections application file C-capp_exe_8_6_7.jar and double click on it.

Note: This assumes that you have copied the cross connections application to your PC so you can work offline (without any connection to the terminals).

The Cross Connections Page

The Cross Connections page is split into two panes with each pane displaying one terminal. The local terminal is displayed in the left pane and the remote terminal is displayed in the right pane.

The local terminal is defined as the terminal that SuperVisor is logged into (not necessarily the near end terminal).

The cards displayed depend on the type of cards and where they are inserted in the chassis.

To view all the ports for each interface card, click on the expand all ports button .

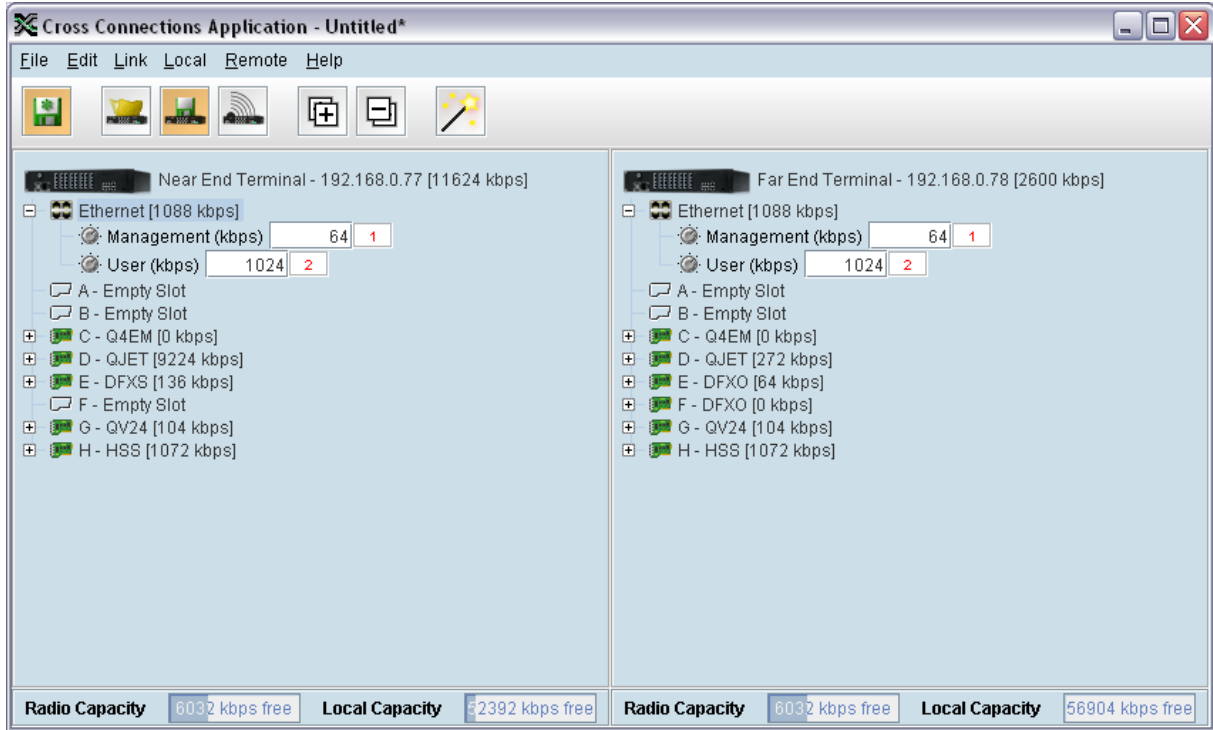

Tool Tips are available by holding the mouse pointer over objects on the screen.

Total Assigned Link Capacity

The current total assigned capacity (radio link and drop and insert) is shown (in kbit/s) beside the terminal name and IP address:



Radio Link and Local Drop And Insert Capacity

At the bottom of the Cross Connections page, the capacity pane displays the Radio and Local drop and insert capacities for both the local and remote terminals.



The **Radio Capacity** field shows the available radio link capacity (6032 kbit/s shown) and the shaded bar graph shows the capacity used for cross connections over the radio link (2600 kbit/s) between the terminals as a percentage of the total capacity of the radio link (30 % used).

The total capacity of the radio link is determined by the channel size and the modulation type of the radio link.

The **Local Capacity** field shows the available capacity for local or drop and insert cross connections (52392 kbit/s shown) and the shaded bar graph shows the capacity used for local cross connections (4512 kbit/s) as a percentage of the total local capacity (7 % used).

The total local capacity is 65536 kbit/s minus the used radio capacity.

Tool tip messages show the breakdown of the radio and local capacity usage:

The following is an example of the messages shown:

Radio Capacity

Radio Bandwidth Usage (over the air)
 8632 kbit/s total
 2600 kbit/s used (30%) of total radio capacity
 6032 kbit/s free







Local Capacity

Local capacity usage (for connecting ports on the same terminal)
 65536 kbit/s total
 8632 kbit/s reserved for radio (13%) of total local capacity
 4512 kbit/s used for local (7%) of total local capacity
 52392 kbit/s free

Tip: On a screen set to 1024 by 768 resolution, this capacity information may be obscured by the task bar if the Windows task bar is docked at the bottom of the screen. To view the capacity pane clearly, either shift the task bar to another screen edge, make it auto-hide, or increase the screen resolution.

Cross Connections Toolbar

The cross connections toolbar has buttons for commonly-used functions.

Button	Explanation
	Saves the cross connection configuration file to disk. The button turns amber when you have made changes that have not yet been saved.
	Gets the cross connection configuration from the local and remote terminals.
	Saves the cross connection configuration to the local and remote terminals. The button turns amber when you have made changes that have not yet been sent to the terminal.
	Activates the cross connections on the local and remote terminals. Turns amber when there are cross connections that have been sent but not yet activated.
	Expands all the ports for all the interface cards.
	Collapses all the ports for all the interface cards.
	Opens the symmetrical connections wizard.

Setting the Terminal's IP Address

If the Cross Connections application is launched from SuperVisor, the terminal IP addresses are set automatically by SuperVisor, but if the application is launched from your PC independent of SuperVisor, you will need to set the application Local and Remote IP addresses to the addresses of the Local and Remote terminals you wish to connect to.

To set the application local or remote IP address:

1. Right-click over the terminal name or IP address and select Set Address.

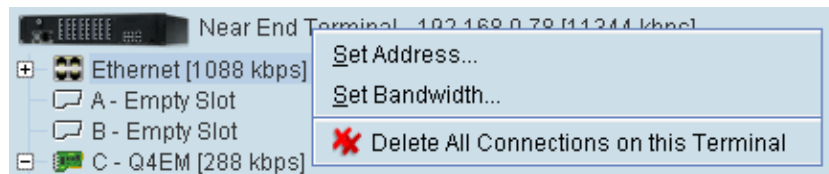

2. Select Local or Remote > Set Address
3. Enter the IP address of the terminal in the dialog box and click OK.

Management and User Ethernet Capacity

The maximum ethernet capacity of an Aprisa XE terminal is dependant on the motherboard version:

Motherboard Version	Maximum Ethernet Capacity
Rev C	32768 kbit/s
Rev D	49152 kbit/s

The maximum ethernet capacity available is the lesser of the maximum ethernet capacity or the available radio link capacity.

The management ethernet capacity and user ethernet capacity must be identical on both terminals for the ethernet link to work correctly.

Management Ethernet Capacity

A management ethernet cross connection between the local and remote terminals is created automatically using the default capacity of 64 kbit/s (connection number = 1). This connection is essential for remote terminal management communication.

The minimum management ethernet capacity requirement for correct management operation over the radio link is 8 kbit/s but if the terminal is on a network with large numbers of broadcast packets, the management may not be able to function.

The management capacity must be set in multiples of 8 kbit/s and the maximum assignable is 64 kbit/s.

User Ethernet Capacity

A user ethernet cross connection between the local and remote terminals is created automatically using the default capacity of 0 kbit/s (connection number = 2).

The user ethernet capacity must be set in multiples of 8 kbit/s.

The maximum user ethernet capacity available is the maximum ethernet capacity available minus the management ethernet capacity setting.

To set the management ethernet or the user ethernet capacity:

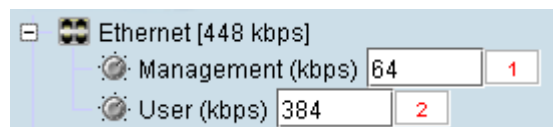

Enter the required kbit/s in the local terminal capacity field. The associated remote terminal capacity field will update automatically.

The red numbers, in the mapping connection boxes, are known as connection numbers and are allocated automatically by the Cross Connections application.

Setting Card Types

Note: You only need to do this when creating configurations offline (that is, there is no connection to the terminal). When you are connected to the terminal, the Cross Connections application automatically detects the card types fitted in the terminal slots.

You can specify the card type for any of the slots (A-H).

1. Right-click a slot.

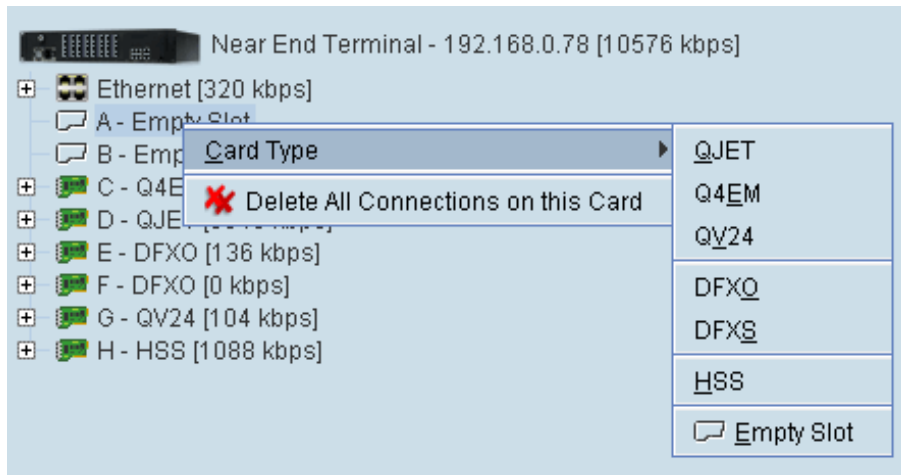

2. Select Card Type and then select the interface card.

Getting Cross Connection Configuration from the Terminals

You can get the entire existing cross connection configuration from the terminals.

1. Download the existing cross connections (if any) from the local and remote terminals by clicking 'Get cross connection configuration from terminal'.



Creating Cross Connections

Point to point cross connections

Three examples of point to point cross connections are shown below:

Example 1

One 2 wire DFXO interface on the near end terminal slot E port 1 is cross connected via the radio link to a 2 wire DFXS on the far end terminal slot E port 1. This cross connection includes the four bits of signalling (ABCD bits) but as the DFXO / DFXS signalling is configured for 'multiplexed', the four bits are multiplexed into one bit over the radio link. This cross connection uses 72 kbit/s of radio link capacity, 64 kbit/s for the voice and 8 kbit/s for the signalling bit.

The port 2s of the same DFXO / DFXS cards are cross connected using the same method.

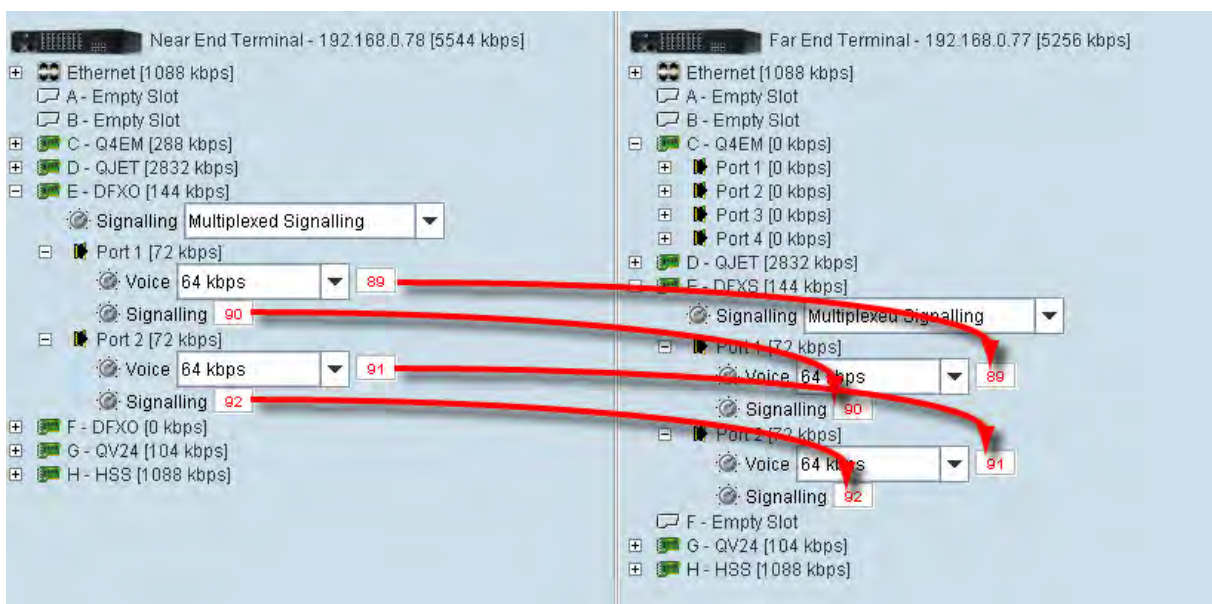

Example 2

One 2 wire DFXS interface on the near end terminal slot E port 1 is cross connected via the radio link to a framed E1 on the far end terminal slot D port 1 in timeslot 1. This cross connection includes four bits of signalling as the DFXS signalling is configured as 'non-multiplexed signalling' (ABCD bits). This cross connection uses 96 kbit/s of radio link capacity, 64 kbit/s for the voice and 32 kbit/s for the signalling bits.

Another 2 wire DFXS interface on the near end terminal slot F port 1 is cross connected via the radio link to a framed E1 on the far end terminal slot D port 1 in timeslot 2. This cross connection includes one bit of signalling as the DFXS signalling is configured in '4 wire compatible' mode (A bit only). This cross connection uses 40 kbit/s of radio link capacity, 32 kbit/s for the ADPCM voice and 8 kbit/s for the signalling bit.

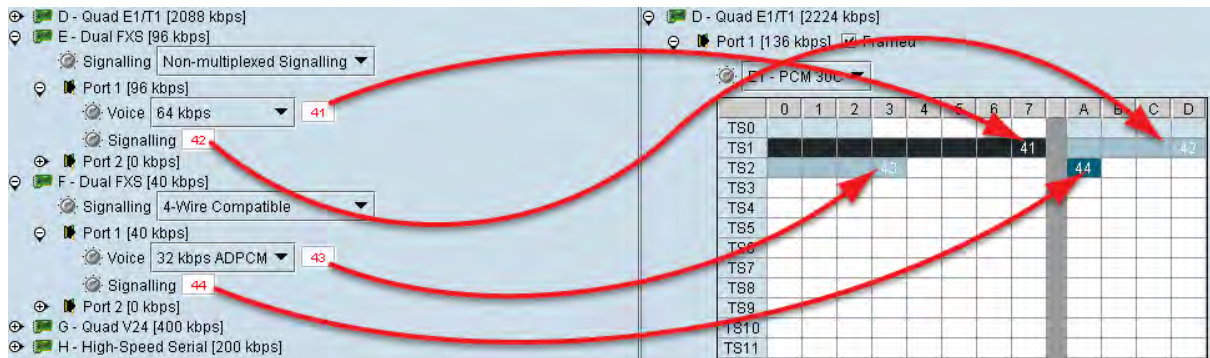

Example 3

One 2 wire DFXS interface on the near end terminal slot E port 1 is cross connected via the radio link to a framed E1 on the far end terminal slot D port 1 in timeslot 1. This cross connection includes one bit of signalling as the DFXS signalling is configured as 'multiplexed' signalling. This cross connection uses 72 kbit/s of radio link capacity, 64 kbit/s for the voice and 8 kbit/s for the signalling bit.

Local Drop and Insert Cross Connections

An example of a local drop and insert cross connection is shown below:

Two 4 wire E&M interfaces on the near end terminal slot C ports 3 & 4 are dropped out of a framed E1 on the near end terminal slot D port 1 in timeslots 1 & 2. This cross connection includes one bit of signalling (A bit).

Another two 4 wire E&M interfaces on the near end terminal slot C ports 1 & 2 are inserted into the radio link to a framed E1 on the far end terminal slot D port 1 in timeslots 1 & 2. This cross connection includes one bit of signalling (A bit).

The remaining framed E1 on the near end terminal slot D port 1 timeslots are transported over the radio link to the framed E1 on the far end terminal slot D port 1. This cross connection includes four bits of signalling (ABCD bits).

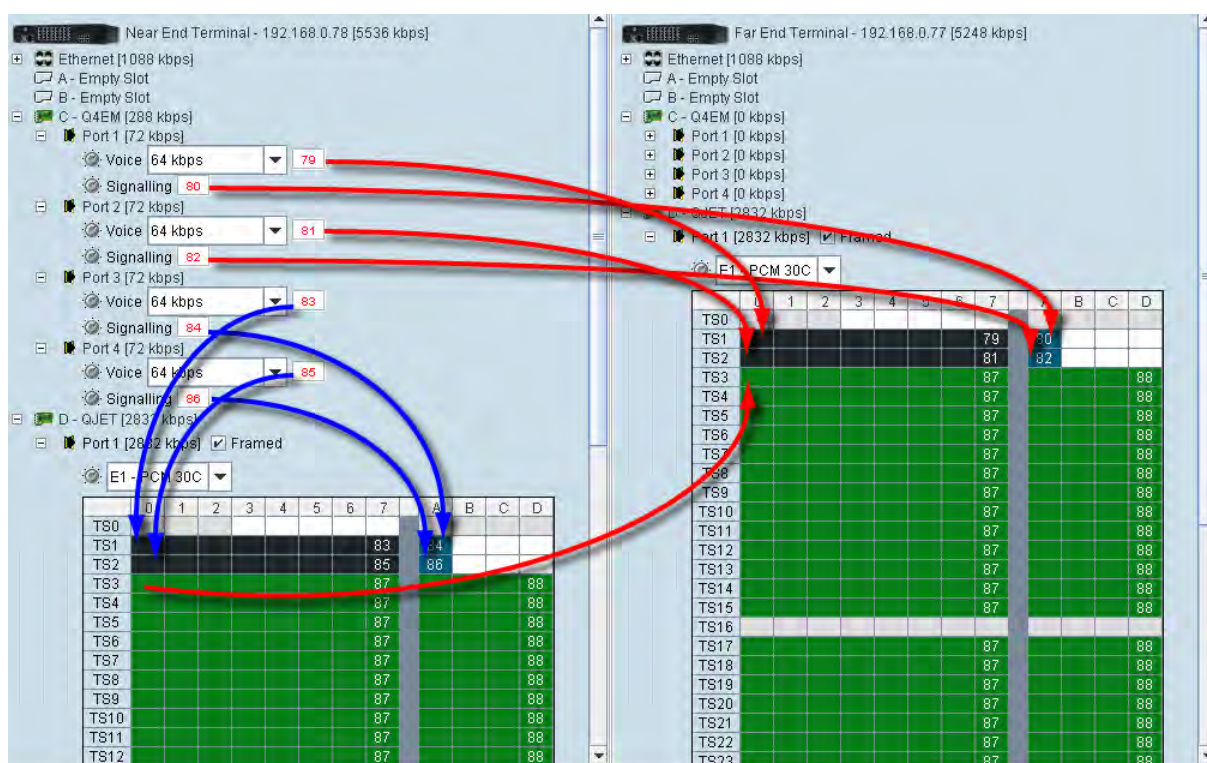

Sending Cross Connection Configuration to the Terminals

You can send the entire cross connection configuration to the terminals.

1. To send the new cross connection configuration into the terminals, click 'Send cross connection configuration to terminal'.



2. When the transfer is successfully complete, a message appears asking if you want to activate the configuration now.

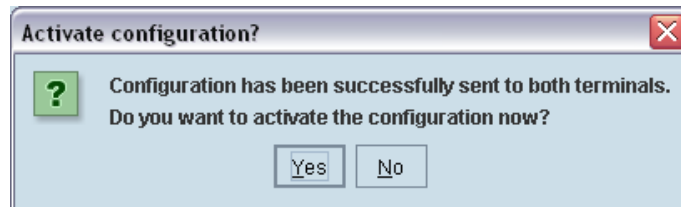

If you click Yes, a message appears showing the activation progress.

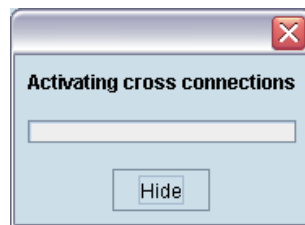

If you click No, you can activate the new cross connection configuration later by clicking 'Activate cross connection configuration'.



Saving Cross Connection Configurations

You can save the entire cross connection configuration to file so that you can restore it to the same link (if this is ever required), or transfer it to another link if you want them to be identical.

1. Click on 'Save cross connection configuration file to disk' or select File > Save.
2. Navigate to the directory where you want to save the file, enter the filename in the dialog box and then click Save.
3. Once you have specified a filename and a directory save any further changes by clicking Save.

Using Existing Cross Connection Configurations

To load a previously-saved cross connection configuration from an existing file:

1. Select File > Open.
2. Navigate to the file and select it, and then click Open.

Printing the Cross Connection Configuration

You can print out a summary of the cross connection configuration so that you can file it for future reference. Using the printout, you can recreate the cross connection configuration.

If you don't have the configuration saved to disk see 'Saving cross connection configurations' on page 155, or use it to review the cross connections without connecting to the terminal.

The cross connection configuration summary shows information for the local and remote terminals such as:

- The IP address and terminal name
- The interface card fitted in each slot
- How the ports are configured

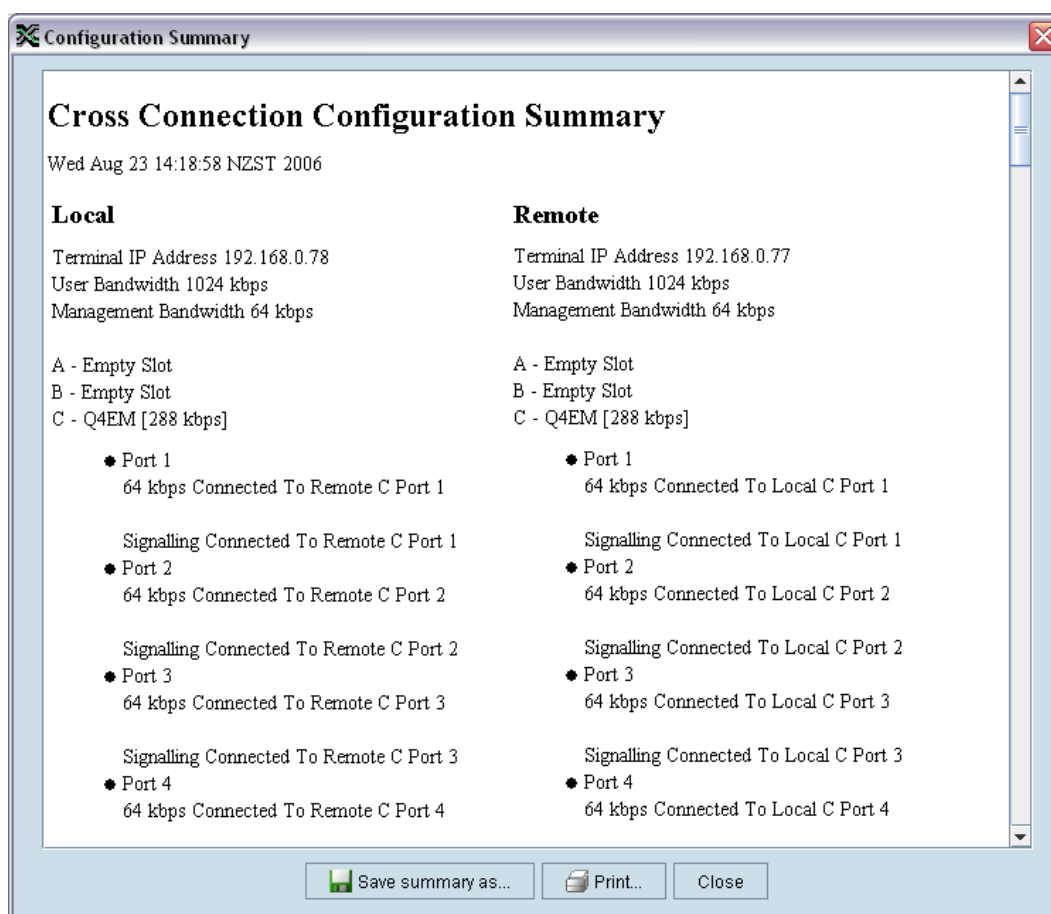

To preview the cross connection configuration summary:

Select File > Preview Configuration Summary.

In this dialog box you can:

- Save the summary to disk (as an HTML file) by clicking Save Summary As.
- Print the summary by clicking Print.
- Copy and paste the information into another application (for example, spreadsheet, email, and word processor) by right-clicking over the summary and selecting Select All. Then right-click over the summary again and select Copy.

To print the cross connection configuration summary:

Select File > Print Configuration Summary.

Deleting Cross Connections

Note: It is not possible to delete the management and user Ethernet cross connections. These are made automatically and are required for correct terminal operation.

To delete cross connections for an interface card:

1. Right-click over an interface card.

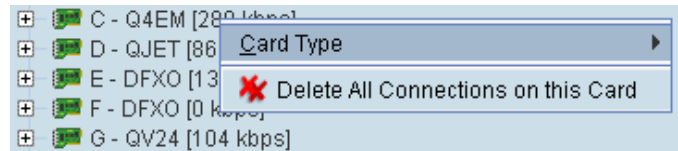

2. Select Delete All Connections on this Card.

To delete the cross connections associated with a particular port:

1. Right-click over a port.

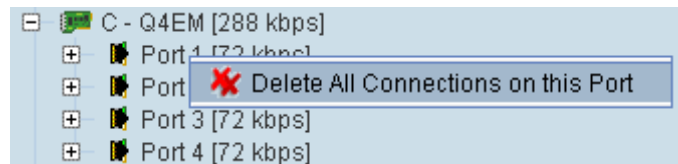

2. Select Delete All Connections on this Port.

To delete all the cross connections for a terminal:

1. Right-click over the terminal name and IP address.

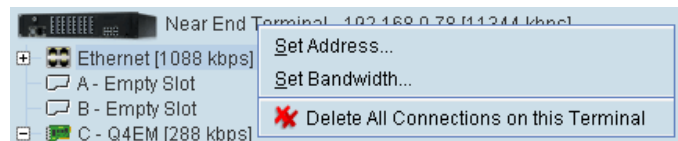

2. Select Delete All Connections on this Terminal.

Configuring the Traffic Cross Connections

Once you have configured the interface cards (see ‘Configuring the traffic interfaces’ on page 91), you can configure the traffic cross connections between compatible interfaces.

Compatible Interfaces

Cross connections can be made between any compatible interfaces of equal data rates. Compatible interfaces are shown in the table below:

	Ethernet (management)	Ethernet (user)	QJET E1 Unframed	QJET T1 Unframed	QJET E1 Framed PCM 31	QJET E1 Framed PCM 30	QJET T1 SF - PTS	QJET T1 SF - DMS	QJET T1 ESF - PTS	QJET T1 ESF - DMS	Q4EM voice only	Q4EM with E&M	QV24 with signalling	DFXO	DFXS	HSS data	HSS signalling
Ethernet (management)	✓																
Ethernet (user)		✓															
QJET E1 Unframed			✓														
QJET T1 Unframed				✓													
QJET E1 Framed PCM 31					✓	✓					✓	✓	✓	✓	✓	✓	✓
QJET E1 Framed PCM 30					✓	✓					✓	✓	✓	✓	✓	✓	✓
QJET T1 SF - PTS							✓										
QJET T1 SF - DMS								✓		✓	✓	✓	✓			✓	✓
QJET T1 ESF - PTS									✓								
QJET T1 ESF - DMS								✓		✓	✓	✓	✓	✓	✓	✓	✓
Q4EM voice only					✓	✓		✓		✓	✓						
Q4EM with E&M					✓	✓		✓		✓		✓		✓	✓		
QV24 with signalling					✓	✓		✓		✓			✓				
DFXO					✓	✓				✓		✓			✓		
DFXS					✓	✓				✓		✓		✓	✓		
HSS data					✓	✓		✓		✓						✓	
HSS signalling					✓	✓		✓		✓							✓

QJET Cross Connections

Expand the E1 / T1 display by clicking on the relevant icons.

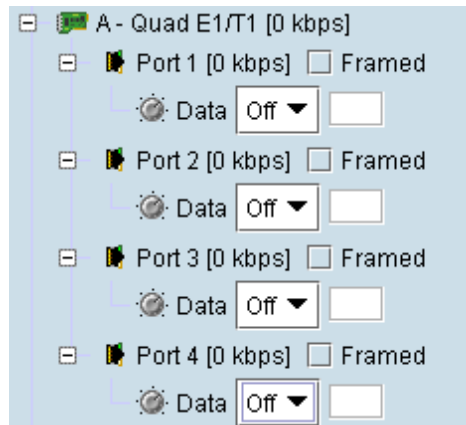

The QJET card can operate in several modes allowing you greater flexibility in tailoring or grooming traffic. The Data type selection are Off, E1, or T1 rates.

Note: An unframed E1 / T1 port requires 5 bits (or 40 kbit/s) of overhead traffic per port for synchronization.

An unframed E1 port with 2048 kbit/s of traffic requires 2088 kbit/s of link capacity.

An unframed T1 port with 1544 kbit/s of traffic requires 1584 kbit/s of link capacity.

For each port that you want to put into service, choose the required mode (either Unframed or Framed):

Unframed Mode

Leave the Framed checkbox unticked.

Select the required Data type from the drop-down list E1 or T1.

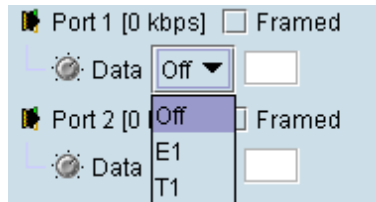

Local drop and insert connections are not possible between Unframed E1 / T1 ports.

Framed Mode

Tick the Framed checkbox.

Select the required framed mode from the drop-down list:

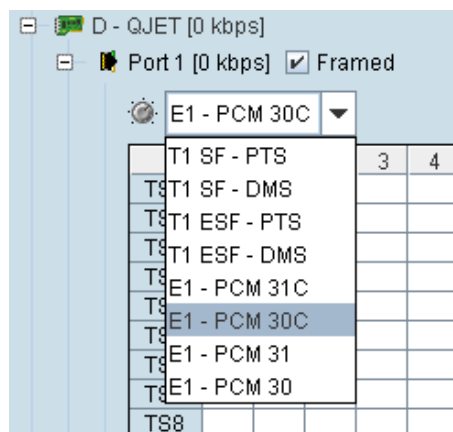

Local drop and insert connections are possible between framed E1 ports on the same interface card or E1 ports on different interface cards.

Local drop and insert connections are possible between framed T1 ports on the same interface card or T1 ports on different interface cards.

Local drop and insert connections are not possible between framed E1 ports and framed T1 ports.

E1 Framed Modes

Framed Mode	Description
E1 - PCM 30	Provides 30 timeslots to transport traffic. Timeslot 16 carries channel associated signalling data (CAS).
E1 - PCM 31	Provides 31 timeslots to transport traffic. Timeslot 16 can be used for common channel signalling or to transport traffic.
E1 - PCM 30C	Same as E1 - PCM 30 mode but supports CRC-4.
E1 - PCM 31C	Same as E1 - PCM 31 mode but supports CRC-4.

E1 CRC-4 (cyclic redundancy check) is used to ensure correct frame alignment and also used to gather E1 performance statistics e.g. Errored Seconds (ES), Severely Errored Seconds (SES).

The first three bits of timeslot 0 NFAS (bits 0,1 & 2) and all of timeslot 0 FAS are not transported across the link, but rather terminated and regenerated at each terminal.

The last five bits of timeslot 0 NFAS (bits 3 - 7) are the National Use Bits (NUBs) which can be cross connected locally or over the link.

E1 - PCM 30 mode

E1 - PCM 30 modes are used when access to the signalling bits (ABCD) is required, for example:

- Splitting a PCM 30 E1 into two separate PCM 30 E1s
- Cross connecting signalling from DFXS, DFXO or Q4EM interfaces into an PCM 30 E1
- Drop and Insert connections between PCM 30 E1s

In PCM 30 / PCM 30C mode, the timeslot table left column is used to map timeslot bits and the timeslot table right column is used to map CAS bits (ABCD) for signalling. Timeslot 16 is reserved to transport the CAS multi frame.

One use of this mode is to connect the 4 wire E&M interfaces to third-party multiplexer equipment over the E1 interface using CAS in TS16 to transport the E&M signalling.

To configure this mode correctly, you must have a detailed knowledge of the CAS signalling modes for the third-party equipment to ensure the signalling bits are compatible and configured to interoperate.

E1 - PCM 31 mode

E1 - PCM 31 modes are used to cross connect timeslots bits without the signalling bits (ABCD).

TS16 can be cross connected between E1 ports (to transport the entire CAS multi frame) or used for common channel signalling or to transport traffic.

The timeslot table left column is used to map timeslot bits but the timeslot table right column for CAS bits (ABCD) is not used.

T1 Framed Modes

Framed Mode	Description
T1 SF - PTS	Provides 24 timeslots to transport traffic using the G.704 12 frame Super Frame with Pass Thru Signalling (PTS). There is no CRC capability with the SF.
T1 SF - DMS	Provides 24 timeslots to transport traffic using the G.704 12 frame Super Frame with DeMultiplexed Signalling (CAS AB bits). There is no CRC capability with the SF.
T1 ESF - PTS	Provides 24 timeslots to transport traffic using the G.704 24 frame Extended Super Frame with Pass Thru Signalling (PTS) and CRC.
T1 ESF - DMS	Provides 24 timeslots to transport traffic using the G.704 24 frame Extended Super Frame with DeMultiplexed Signalling (CAS ABCD bits) and CRC.

T1 SF - PTS mode

T1 SF - PTS mode provides 24 timeslots to transport traffic using the G.704 12 frame Super Frame without demultiplexing the signalling.

Pass Thru Signalling provides cross connection of the entire framed T1 timeslot between T1 ports (including the inherent robbed bit signalling). This is the most efficient method of transporting a framed T1 over the radio link as no additional radio link capacity is required to transport the signalling because the CAS is not demultiplexed.

To maintain multi frame alignment between two framed T1 ports, a FPS (Frame Pattern Sync) bit is required to be cross connected between the two framed T1 ports. This FPS bit requires an additional 8 kbit/s of radio link capacity.

The timeslot table left column is used to map timeslot bits but the timeslot table right column for CAS bits (ABCD) is not used.

T1 SF - PTS mode is used when access to the signalling bits is not required but are transported between T1s, for example:

- Drop and Insert connections between Super Frame T1s or data interfaces

T1 SF - DMS mode

T1 SF - DMS mode provides 24 timeslots to transport traffic using the G.704 12 frame Super Frame with four state demultiplexed signalling using the AB bits each with a bit rate of 333 bit/s.

DeMultiplexed Signalling allows the cross connection of framed T1 ports to other interface ports e.g. to a Q4EM or HSS. An additional 8 kbit/s of radio link capacity is required to transport each CAS bit over the radio link.

The mapping left column is used to map timeslot bits and the timeslot table right column is used to map the CAS A&B bits for signalling (C&D bits are not used).

T1 SF - DMS mode is used when access to the signalling bits is required, for example:

- Cross connecting signalling from a Q4EM interfaces into a 12 frame Super Framed T1.
- Drop and Insert connections between Super Framed T1s or data interfaces

T1 ESF - PTS mode

T1 ESF - PTS mode provides 24 timeslots to transport traffic using the G.704 24 frame Extended Super Frame without demultiplexing the signalling.

Pass Thru Signalling provides cross connection of the entire framed T1 timeslot between T1 ports (including the inherent robbed bit signalling). This is the most efficient method of transporting a framed T1 over the radio link as no additional radio link capacity is required to transport the signalling because the CAS is not demultiplexed.

To maintain multi frame alignment between two framed T1 ports, a FPS (Frame Pattern Sync) bit is required to be cross connected between the two framed T1 ports. This FPS bit requires an additional 8 kbit/s of radio link capacity.

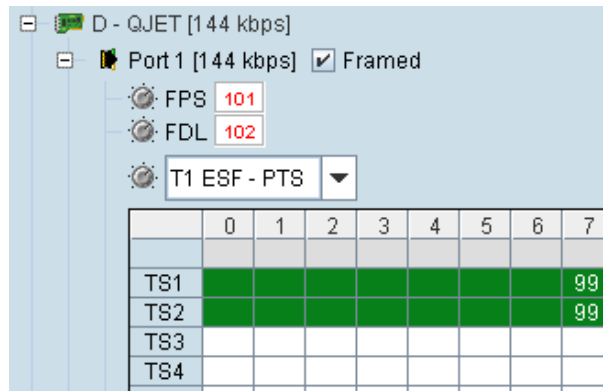

The FDL (Facility Data Link) can be cross connected between the two framed T1 ports if required. This FDL bit requires an additional 8 kbit/s of radio link capacity.

The timeslot table left column is used to map timeslot bits but the timeslot table right column for CAS bits (ABCD) is not used.

T1 ESF - PTS mode is used when access to the signalling bits is not required but are transported between T1s, for example:

- Drop and Insert connections between 24 frame Extended Super Framed T1s or data interfaces

T1 ESF - DMS

T1 ESF - DMS mode provides 24 timeslots to transport traffic using the G.704 24 frame Extended Super Frame with sixteen state demultiplexed signalling using the ABCD bits each with a bit rate of 333 bit/s.

DeMultiplexed Signalling allows the cross connection of framed T1 ports to other interface ports e.g. to a Q4EM or HSS. An additional 8 kbit/s of radio link capacity is required to transport each CAS bit over the radio link.

The FDL (Facility Data Link) can be cross connected between the two framed T1 ports if required. This FDL bit requires an additional 8 kbit/s of radio link capacity.

The mapping left column is used to map timeslot bits and the timeslot table right column is used to map the CAS ABCD bits for signalling.

T1 ESF - DMS mode is used when access to the signalling bits is required, for example:

- Cross connecting signalling from DFXS, DFXO or Q4EM interfaces into a 24 frame Extended Super Framed T1 using 'non-multiplexed' signalling from the interface.
- Drop and Insert connections between 24 frame Extended Super Framed T1s or data interfaces

QJET Spare CAS Bit Control

The Aprisa XE can currently provide E1 CAS to DFXS circuits using the 1 bit '4 wire compatible' signalling mode (uses the CAS A bit) but to enable some exchange DTIs to operate, the state of the spare CAS bits sent to the exchange must be preset.

The available CAS bits can be preset to High (1) or Low (0) for the QJET framed modes of E1 - PCM30, E1 - PCM30C, T1 SF - DMS and T1 ESF - DMS for all timeslots of the port.

To preset the spare CAS bits:

Right click on the CAS bit required to be set.

Select 'Set High CAS Bit x' or 'Set Low CAS Bit x'.

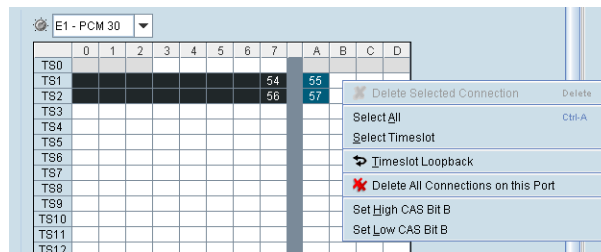

The screen shot shows the standard configuration where the DFXS signalling using 1 bit '4 wire compatible' signalling mode is mapped to the QJET CAS A bit and the 'spare' CAS bits are preset to the standard 1 bit protocol spare bit pattern of BCD = 101.

	0	1	2	3	4	5	6	7	A	B	C	D
TS0												
TS1								54	55	H	L	H
TS2								56	57	H	L	H
TS3										H	L	H
TS4										H	L	H
TS5										H	L	H
TS6										H	L	H
TS7										H	L	H
TS8										H	L	H
TS9										H	L	H
TS10										H	L	H
TS11										H	L	H
TS12										H	L	H
TS13										H	L	H
TS14										H	L	H
TS15										H	L	H
TS16												
TS17										H	L	H
TS18										H	L	H
TS19										H	L	H
TS20										H	L	H
TS21										H	L	H
TS22										H	L	H
TS23										H	L	H
TS24										H	L	H
TS25										H	L	H
TS26										H	L	H
TS27										H	L	H
TS28										H	L	H
TS29										H	L	H
TS30										H	L	H
TS31										H	L	H

Selecting and Mapping Bits and Timeslots

This section describes how to select and map:

- a single bit
- multiple bits
- a 64 kbit/s timeslot
- multiple timeslots

Selecting a Single Bit

Each timeslot is represented by 8 rectangles (each representing a single bit). Each bit can carry 8 kbit/s.

One or more consecutive bits can be selected in a timeslot if a rate of greater than 8 kbit/s is required.

1. Click on the rectangle that represents the bit you require. It will turn red.

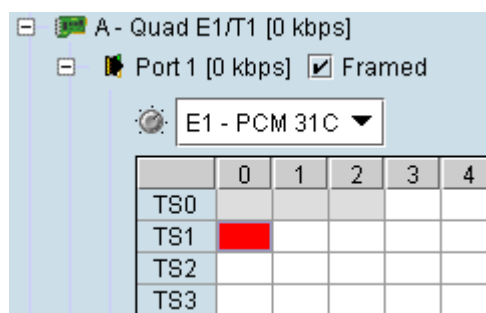

2. Click and drag this bit to the rectangle representing the bit on the interface you want it to be connected to, and release the mouse button.

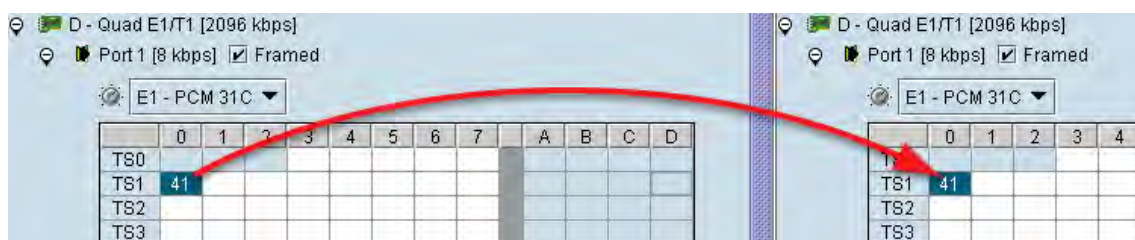

The red rectangle will be replaced by the allocated connection number at each interface.

Selecting a 64 kbit/s Timeslot

1. Click on the TSX timeslot number (where X is the desired timeslot from 1 to 31).

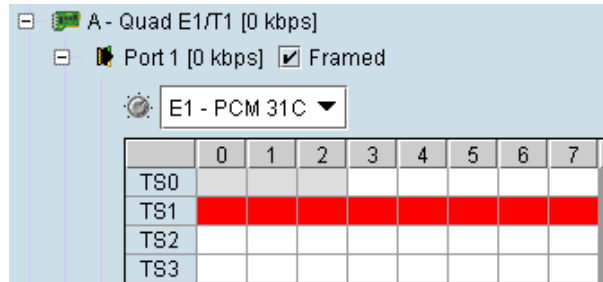

Alternatively, right-click over any of the bits in the timeslot, and click on Select Timeslot.

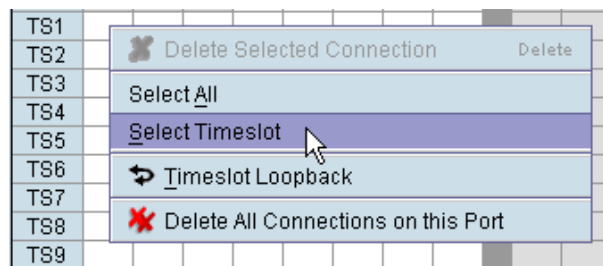

2. Drag and drop in the normal way to complete the cross connection.

Selecting Multiple Non Consecutive Timeslots

1. Click on one TSn timeslot number (where n is the desired timeslot 1 to 31).
2. Hold down the Ctrl key while clicking on each of the required timeslot numbers.

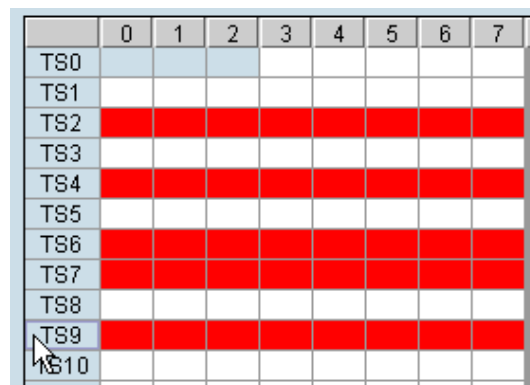

3. Drag and drop in the normal way to complete the cross connection.

Selecting Multiple Consecutive Timeslots

1. Click on the first TS_n timeslot number (where n is the desired timeslot 1 to 31).
2. Hold down the Shift key while clicking on the last required timeslot number.

	0	1	2	3	4	5	6	7
TS0								
TS1								
TS2								
TS3								
TS4								
TS5								
TS6								
TS7								
TS8								
TS9								
TS10								
TS11								
TS12								
TS13								
TS14								
TS15								
TS16								
TS17								

3. Drag and drop in the normal way to complete the cross connection.

Selecting All Timeslots in a Port

1. Right-click over any of the rectangles.

TS2								
TS3								
TS4								
TS5								
TS6								
TS7								
TS8								
TS9								
TS10								

✖ Delete Selected Connection Delete

Select All

Select Timeslot

↻ Timeslot Loopback

✖ Delete All Connections on this Port

2. Click Select All.

Q4EM Cross Connections

1. Expand the Q4EM display by clicking the relevant  icon.

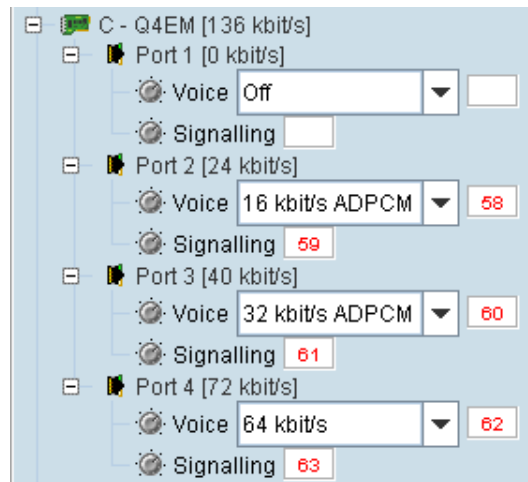

2. Set the Voice capacity by selecting 16, 24, 32, or 64 kbit/s rates.
3. Drag and drop from the **Voice** mapping connection box to the required partner interface to create the voice cross connection.
4. If E&M signalling is required, drag and drop from the **Signalling** mapping connection box to the required partner interface to create the E&M cross connection.

DFXS and DFXO Cross Connections

1. On one side of the link, expand the DFXS display, as required, by clicking

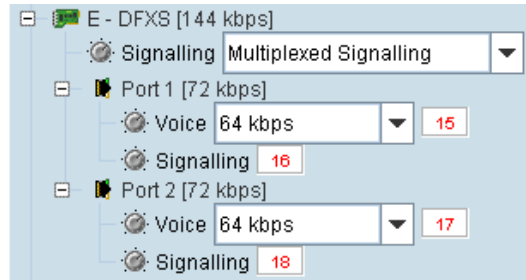

2. On the other side of the link, expand the corresponding DFXO display, as required, by clicking .

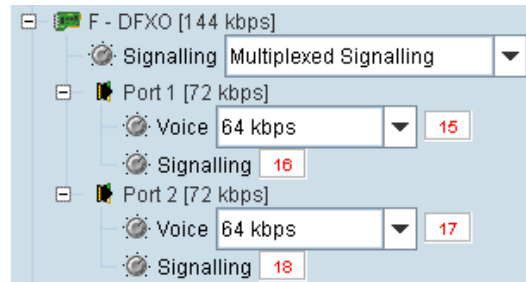

3. For the DFXS card and corresponding DFXO card, select the Signalling **type** as required, according to the table below. The CAS signalling between DFXO / DFXS interfaces uses 4RF proprietary allocation of control bits.

The **Signalling** type affects both ports of the DFXO / DFXS interface. If a mixture of signalling types is required, then multiple DFXO / DFXS cards are needed.

Signalling	Application	Overhead
Multiplexed (default)	Multiplexers the four ABCD bits from the interface into a single 8 kbit/s channel. Use when interworking DFXO to DFXS, between an XE and a SE radio or when limited bandwidth is available. This signalling type cannot be used for interworking between framed E1 / T1 and voice interfaces.	8 kbit/s
Non-multiplexed	Transports each of the four ABCD bits in separate 8 kbit/s channels. Use when interworking DFXO to DFXS, or when signalling bits are mapped into an E1 / T1 timeslot.	32 kbit/s
4 wire compatible	1 bit CAS using only the A bit in both directions of transmission. Use when interworking the DFXS to Q4EM, DFXO to Q4EM, DFXS to DFXS or DFXS to QJET for DTI circuits.	8 kbit/s

4. Set the Voice capacity and create the Voice connection by dragging and dropping between the mapping connection boxes of the DFXO and DFXS corresponding ports.
5. Link the **Port Signalling** connection by dragging and dropping between the mapping connection boxes of the DFXO and DFXS corresponding ports. The DFXO / DFXS control signals (off hook, ring, etc) will not function without this connection.

QV24 Cross Connections

1. Expand the QV24 displays, as required, by clicking the relevant  icons.

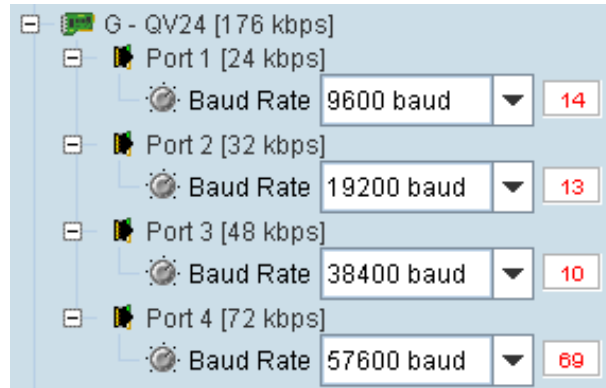

2. Select the Port Baud Rate as required (default is 9600).
3. Drag and drop to the required partner interface to create the V.24 Data connection.

If the partner interface is a QJET:

- If the V.24 Baud Rate selected is 38400 or less, drag from the QV24 mapping connection box to the QJET timeslot. The correct QJET capacity for the baud rate selected will automatically be assigned.
- If the V.24 Baud Rate selected is greater than 38400, select the QJET capacity required, as per the following table, and drag from the QJET to the QV24 mapping connection box.

Baud Rate	Bits Required	Bit Rate
300 - 7200	2	16 kbit/s
9600 - 14400	3	24 kbit/s
19200 - 23040	4	32 kbit/s
28800	5	40 kbit/s
38400	6	48 kbit/s
57600	9	72 kbit/s
115200	16	128 kbit/s

QV24S Cross Connections

Synchronous Mode

1. Expand the QV24S displays, as required, by clicking the relevant icons.

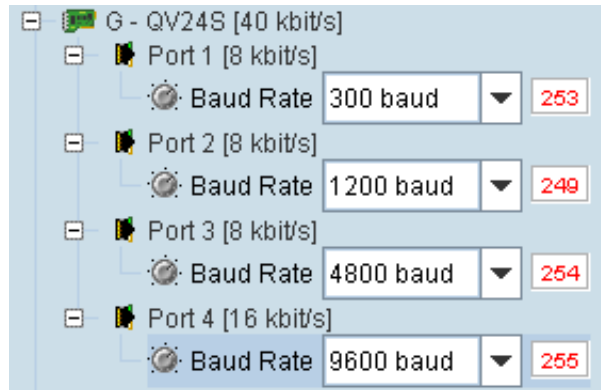

2. Select the Port Baud Rate as required (default is 9600).
3. Drag and drop to the required partner interface to create the V.24 Data connection.
If the partner interface is a QJET, drag from the QV24S mapping connection box to the QJET timeslot. The correct QJET capacity for the baud rate selected will automatically be assigned.

Baud Rate	Bits Required	Bit Rate
300 - 4800	1	8 kbit/s
9600	2	16 kbit/s
19200	4	32 kbit/s

Over Sampling Mode

1. Expand the QV24S displays, as required, by clicking the relevant icons.

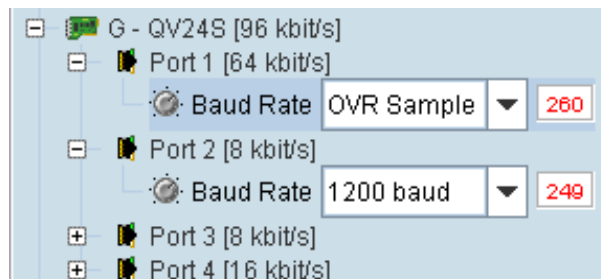

2. Set the Port Baud Rate to OVR Sample.
3. Drag and drop to the required E1 / T1 partner interface to create the data connection.

HSS Cross Connections

1. Expand the HSS displays, as required, by clicking the relevant  icons.

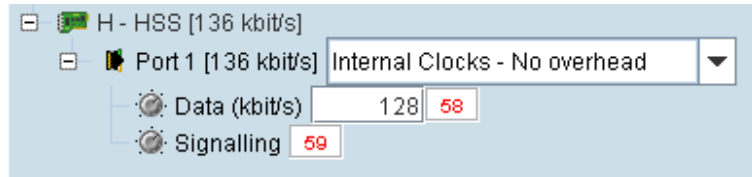

2. Select the **Synchronous Clock Selection** mode (see ‘HSS Synchronous Clock Selection Modes’ on page 138).

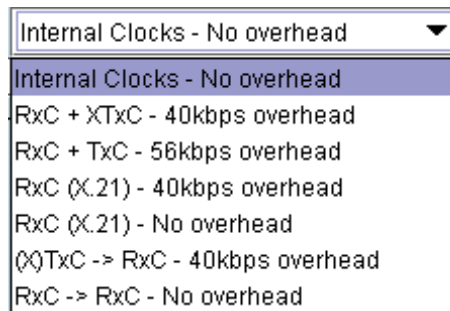

3. Set the **Data** rate to a value between 8 and 2048 (in multiples of 8 kbit/s).

The net data rate available to the user is defined by Data Rate - overhead

e.g. a data rate set to 2048 kbit/s with an overhead of 40 kbit/s provides a user data rate of 2008 kbit/s.

4. Drag and drop to the required partner interface to create the HSS Data connection.

If the partner interface is a QJET, select the capacity on the QJET and drag it to the HSS Data mapping connection box.

The QJET capacity selected must be the sum of the data rate required plus the overhead rate selected.

5. Drag and drop to the required partner interface to create the HSS Signalling cross connection. A minimum of 8 kbit/s of capacity is required and must be set symmetrically at both ends of the link.

Cross Connection Example

This is an example of cross connection mapping:

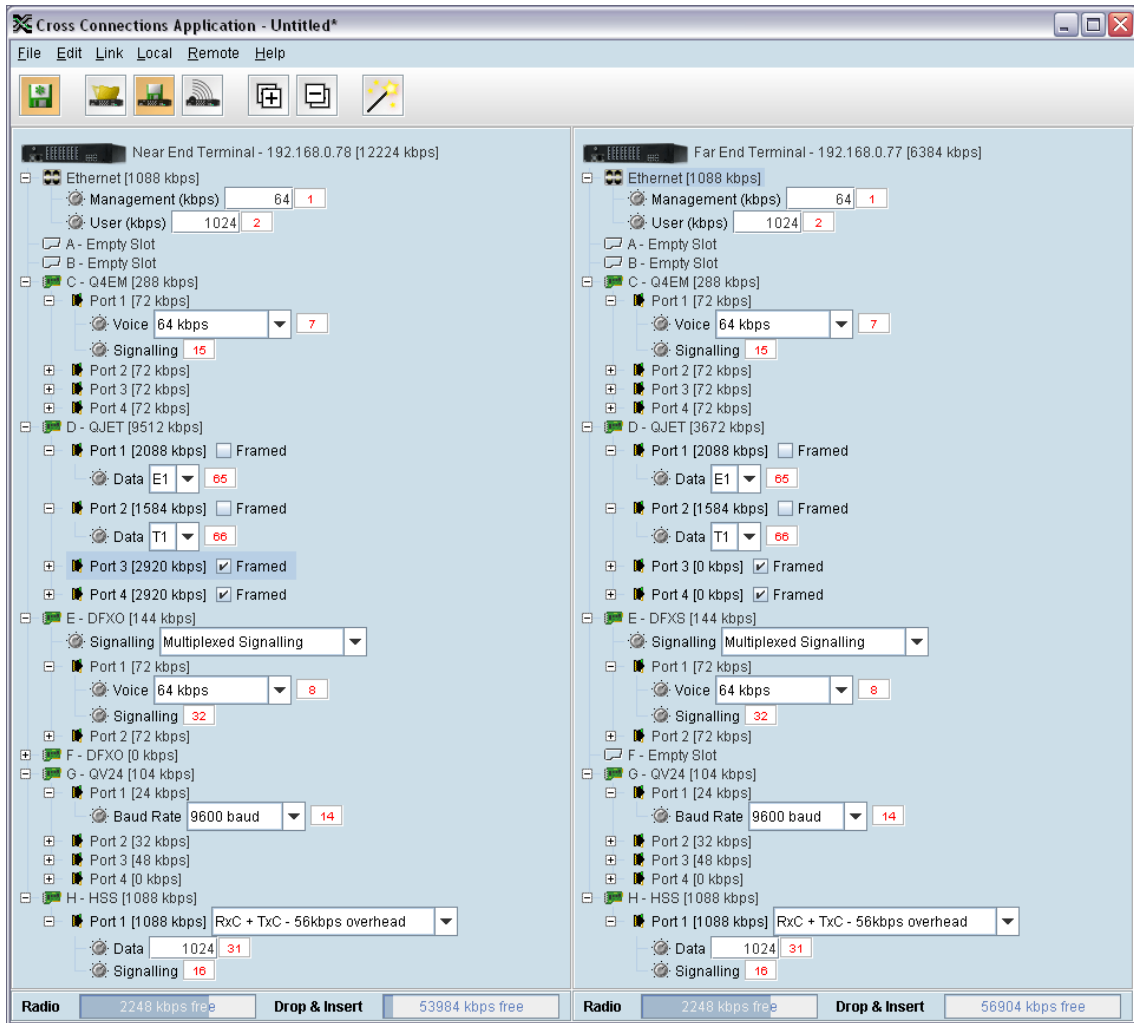

Circuit	Local port	Remote port	Capacity (kbit/s)	Connection numbers
Radio management			64	1
User Ethernet			1024	2
4 wire E&M circuit	Q4EM port 1 (slot C)	Q4EM port 1 (slot C)	72	7/15
Unframed E1 data	QJET port 1 (slot D)	QJET port 1 (slot D)	2088	65
Unframed T1 data	QJET port 2 (slot D)	QJET port 2 (slot D)	1584	66
2 wire loop Interface	DFXO port 1 (slot E)	DFXS port 1 (slot E)	72	8/32
V.24 data circuit 9600	QV24 port 1 (slot G)	QV24 port 1 (slot G)	24	14
HSS data circuit 1024 kbit/s	HSS port 1 (slot H)	HSS port 1 (slot H)	1088	31/16

Symmetrical Connection Wizard

The Cross Connections application has a Symmetrical Connection Wizard which simplifies the cross connection configuration when the terminals are fitted with symmetrical / matching interface types.

A symmetrical connection is a connection between the local and the remote terminal where the local slot, card type, port and connection details are identical to those of the remote terminal.

The only exception is DFXO / DFXS connections where DFXO cards are considered to match DFXS cards (as they normally interwork).

Framed E1 / T1 CAS connections, drop-and-insert connections, and connections that do not involve entire timeslots, are considered to be asymmetrical.

Starting the Cross Connections Wizard

When starting the connection wizard with unsaved changes, the following popup dialog should appear

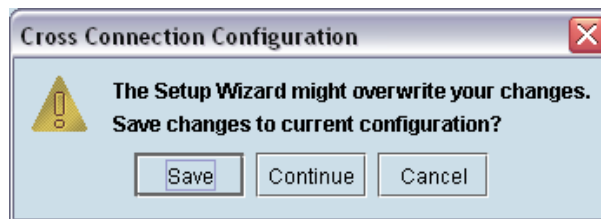

Click on 'Save' if you wish to save the current configuration to a file. Clicking on 'Continue' will continue with the wizard and overwrite any changes made when the wizard finishes.

The wizard can be cancelled at any time by clicking on the 'Cancel' button or by closing the window.

Cross Connections Wizard Navigation

Click on the Next button to progress through the connection wizard. The current stage is indicated in the navigation bar on the left. You can jump directly to a stage by clicking on the stage required.

Setting the Cross Connections IP Address

If the local or remote terminal IP addresses have been setup, they will be displayed in the Local and Remote fields. If the IP addresses are not displayed, enter the IP addresses of the local and remote terminals.

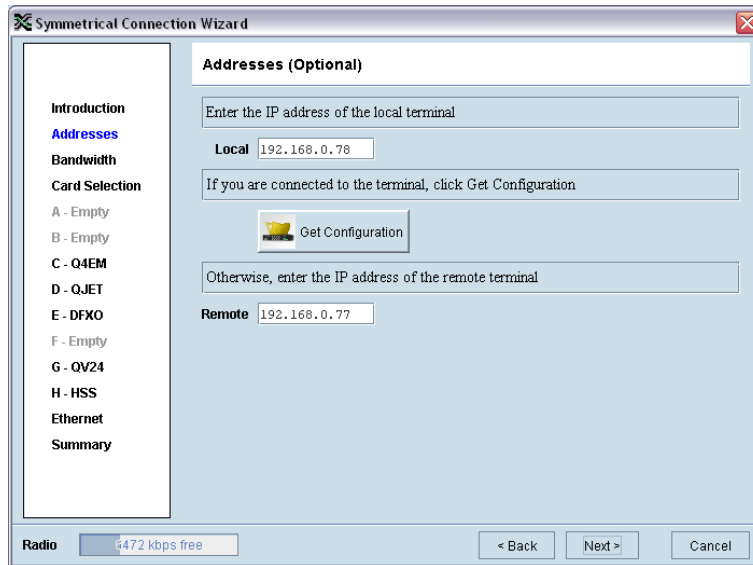

Click on 'Get Configuration' to upload the existing cross connections configuration from the local terminal. The Radio bandwidth bar will show the available bandwidth and will be updated as bandwidth is assigned to cards.

Setting the Cross Connections Bandwidth

If the Cross Connections Application is opened from SuperVisor, the Total Capacity of the radio link will be shown in the Bandwidth field.

If the Cross Connections Application is opened as a stand alone application, the Total Capacity of the radio link will be need to be entered in the Bandwidth field.

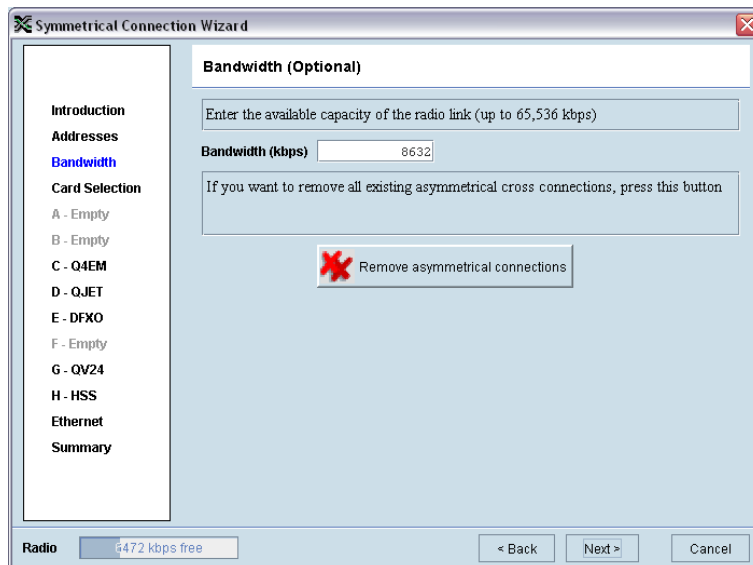

The 'Remove asymmetrical connections' button will be active if there are existing asymmetrical cross connections. If you want to remove existing asymmetrical cross connections, click on this button. The Radio bandwidth bar will update accordingly.

Cross Connections Card Selection

If the Cross Connections Application is opened from SuperVisor, existing cards installed in the local terminal that match cards installed in the remote terminal will be displayed. Mismatched cards will be shown as 'Empty Slot'.

If the Cross Connections Application is opened as a stand alone application, select the card types that will be fitted in the terminal.

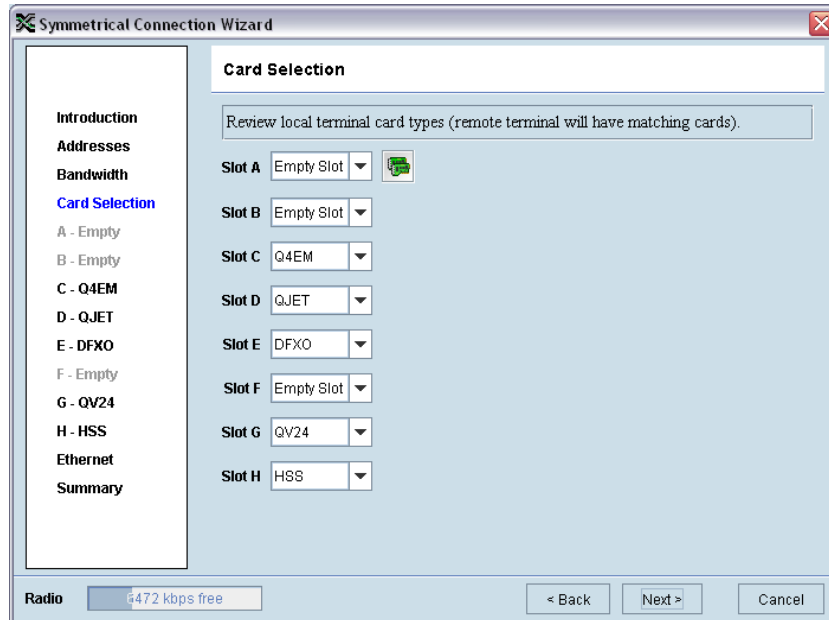

To copy the card type selected in Slot A to all the other slots (B - H), click on the Copy Card button. This assumes that the same interface card types are fitted in all the card slots.



Cross Connections Interface Configurations

Setup the interface configurations as per the wizard instructions. Existing asymmetrical connections will be replaced with symmetrical connections if an interface parameter is changed.

Q4EM

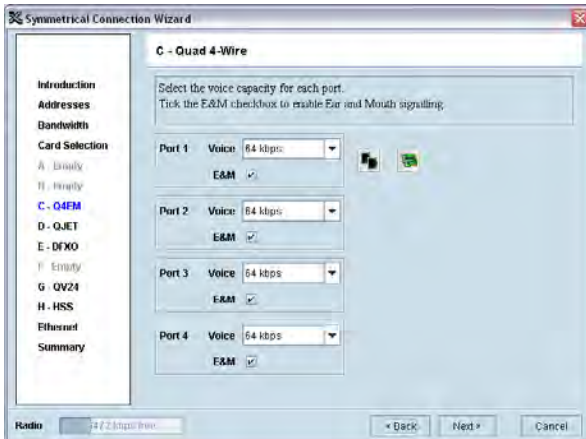

QJET

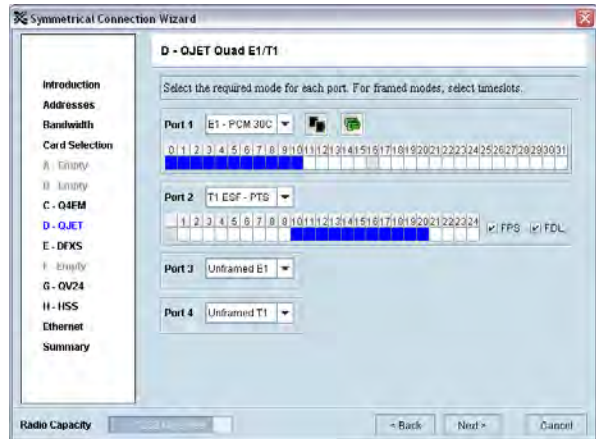

DFXO / DFXS

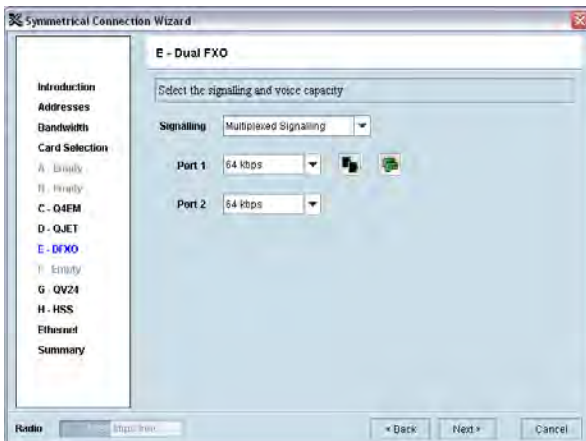

QV24



HSS

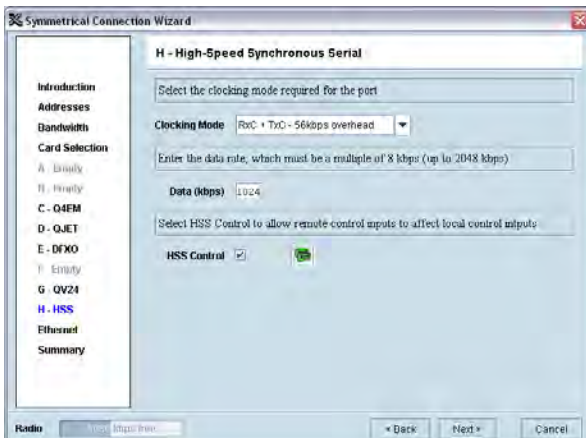

Ethernet

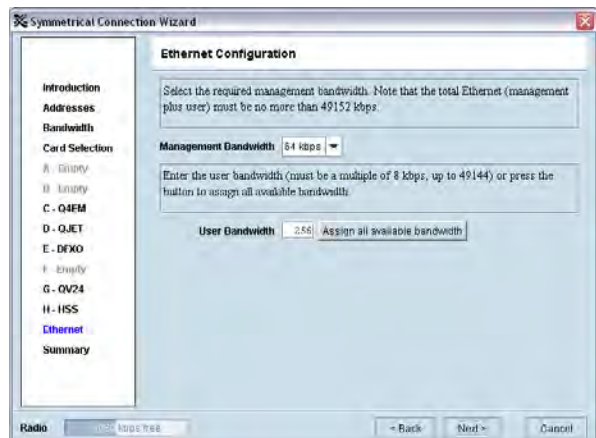

To copy the port configuration selected in Port 1 to all the other ports on the card, click on the Copy Port button.



To copy the card configuration to all other cards of the same type fitted in the terminal, click on the Copy Card button. This can save time when setting up multiple cards of the same type.



Symmetrical Connection Summary

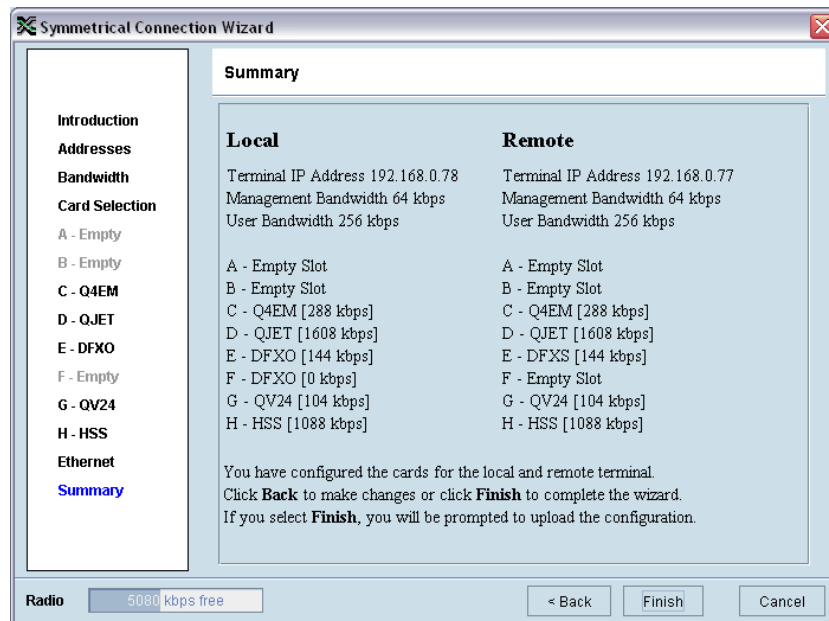

Click Finish.

Send Symmetrical Connection Configuration

Click OK to send the configuration to the terminals.

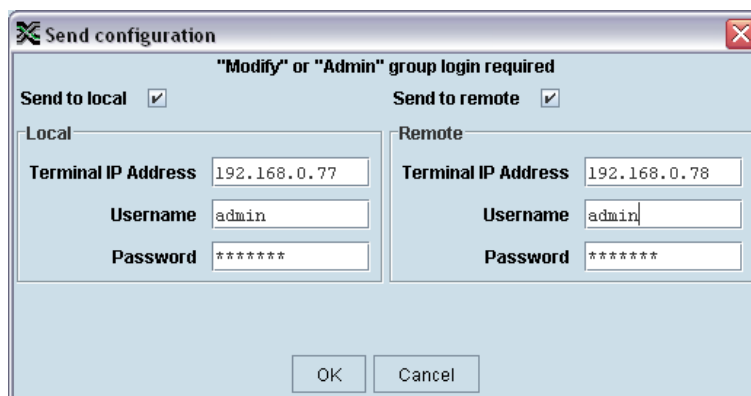

The process is completed.

Note: The wizard may change the connection numbers of existing connections.
