



*Aprisa* **SRi**



# User Manual

Standard Radio

July 2016

Version 1.0.0b



## Copyright

Copyright © 2016 4RF Limited. All rights reserved.

This document is protected by copyright belonging to 4RF Limited and may not be reproduced or republished in whole or part in any form without the prior written permission of 4RF Limited.

## Trademarks

Aprisa and the 4RF logo are trademarks of 4RF Limited.

Windows is a registered trademark of Microsoft Corporation in the United States and other countries. Java and all Java-related trademarks are trademarks or registered trademarks of Sun Microsystems, Inc. in the United States and other countries. All other marks are the property of their respective owners.

## Disclaimer

Although every precaution has been taken preparing this information, 4RF Limited assumes no liability for errors and omissions, or any damages resulting from use of this information. This document or the equipment may change, without notice, in the interests of improving the product.

## RoHS and WEEE Compliance

The Aprisa SRi is fully compliant with the European Commission's RoHS (Restriction of Certain Hazardous Substances in Electrical and Electronic Equipment) and WEEE (Waste Electrical and Electronic Equipment) environmental directives.

### Restriction of hazardous substances (RoHS)

The RoHS Directive prohibits the sale in the European Union of electronic equipment containing these hazardous substances: lead, cadmium, mercury, hexavalent chromium, polybrominated biphenyls (PBBs), and polybrominated diphenyl ethers (PBDEs).

4RF has worked with its component suppliers to ensure compliance with the RoHS Directive which came into effect on the 1<sup>st</sup> July 2006.

### End-of-life recycling programme (WEEE)

The WEEE Directive concerns the recovery, reuse, and recycling of electronic and electrical equipment. Under the Directive, used equipment must be marked, collected separately, and disposed of properly.

4RF has instigated a programme to manage the reuse, recycling, and recovery of waste in an environmentally safe manner using processes that comply with the WEEE Directive (EU Waste Electrical and Electronic Equipment 2002/96/EC).

4RF invites questions from customers and partners on its environmental programmes and compliance with the European Commission's Directives (sales@4RF.com).

## Compliance General

The Aprisa SRi radio predominantly operates within frequency bands that are covered under a class license or general user license which is a license issued to 'every person'.

Changes or modifications not approved by the party responsible for compliance could void the user's authority to operate the equipment.

Equipment authorizations sought by 4RF are based on the Aprisa SRi radio equipment being installed at a fixed restricted access location and operated in point-to-multipoint or point-to-point mode within the environmental profile defined by EN 300 019, Class 3.4. Operation outside these criteria may invalidate the authorizations and / or license conditions.

The term 'Radio' with reference to the Aprisa SRi User Manual, is a generic term for one end station of a point-to-multipoint Aprisa SRi network and does not confer any rights to connect to any public network or to operate the equipment within any territory.

## Compliance Federal Communications Commission

The Aprisa SRi radio is designed to comply with the USA Federal Communications Commission (FCC) specifications as follows:

Radio	47CFR part 15.247
EMC	47CFR part 15 Radio Frequency Devices
Environmental	EN 300 019, Class 3.4 Ingress Protection IP51
Safety	EN 60950-1:2006 Class 1 division 2 for hazardous locations

Frequency Band *	Channel size	Power input	Authorization	FCC ID
902-928 MHz	50 kHz	13.8 VDC	Part 15.247	Pending

NOTE: This equipment has been tested and found to comply with the limits for a Class A digital device, pursuant to part 15 of the FCC Rules. These limits are designed to provide reasonable protection against harmful interference when the equipment is operated in a commercial environment. This equipment generates, uses, and can radiate radio frequency energy and, if not installed and used in accordance with the instruction manual, may cause harmful interference to radio communications. Operation of this equipment in a residential area is likely to cause harmful interference in which case the user will be required to correct the interference at his own expense.

\* The Frequency Band is not an indication of the exact frequencies approved by FCC.

## Compliance Industry Canada

The Aprisa SRi radio is designed to comply with Industry Canada (IC) specifications as follows:

Radio	RSS-247			
EMC	This Class A digital apparatus complies with Canadian standard ICES-003. Cet appareil numérique de la classe A est conforme à la norme NMB-003 du Canada.			
Environmental	EN 300 019, Class 3.4 Ingress Protection IP51			
Safety	EN 60950-1:2006 Class 1 division 2 for hazardous locations			
Frequency Band *	Channel size	Power input	Authorization	IC
902-928 MHz	50 kHz	13.8 VDC	RSS-247	Pending

\* The Frequency Band is not an indication of the exact frequencies approved by IC.

This device complies with Part 15 of the FCC Rules and Industry Canada's licence exempt RSSs. Operation is subject to the following two conditions: (1) This device may not cause interference; and (2) This device must accept any interference, including interference that may cause undesired operation of the device.

Ce dispositif est conforme à la partie 15 des règles de la Federal Communications Commission (FCC) des États Unis et d'Industrie Canada (IC) exempts de licence RSS norme(s). Son fonctionnement est assujetti aux deux conditions suivantes: (1) Ce dispositif ne doit pas provoquer de brouillage préjudiciable, et (2) il doit accepter tout brouillage reçu, y compris le brouillage pouvant entraîner un mauvais fonctionnement.

## Compliance ACMA

The Aprisa SRi radio is designed to comply with Australia ACMA specifications as follows:

Radio	Radio Communications (Short Range Devices) Standard 2004
EMC	AS/NZS 4268
Environmental	EN 300 019, Class 3.4 Ingress Protection IP51
Safety	EN 60950-1:2006 Class 1 division 2 for hazardous locations

Frequency Band *	Channel size	Power input	Authorization	ACMA
915-928 MHz	50 kHz	13.8 VDC		Pending

## Compliance RSM

The Aprisa SRi radio is designed to comply with New Zealand RSM specifications as follows:

Radio / EMC	AS/NZS 4268
Environmental	EN 300 019, Class 3.4 Ingress Protection IP51
Safety	EN 60950-1:2006 Class 1 division 2 for hazardous locations

Frequency Band *	Channel size	Power input	Authorization	RSM
915-928 MHz	50 kHz	13.8 VDC	Licence 252286	Pending

## Compliance Hazardous Locations Notice

This product is suitable for use in Class 1, Division 2, Groups A - D hazardous locations or non-hazardous locations.

The following text is printed on the Aprisa SRi fascia:

**WARNING: EXPLOSION HAZARD** - Do not connect or disconnect while circuits are live unless area is known to be non-hazardous.

The following text is printed on the Aprisa SRi where the end user is in Canada:

**AVERTISSEMENT: RISQUE D'EXPLOSION** - Ne pas brancher ou débrancher tant que le circuit est sous tension, à moins qu'il ne s'agisse d'un emplacement non dangereux.

The USB service ports are not to be used unless the area is known to be non-hazardous.



## RF Exposure Warning



**WARNING:**

The installer and / or user of Aprisa SRi radios shall ensure that a separation distance as given in the following table is maintained between the main axis of the terminal's antenna and the body of the user or nearby persons.

Minimum separation distances given are based on the maximum values of the following methodologies:

1. Maximum Permissible Exposure non-occupational limit (B or general public) of 47 CFR 1.1310 and the methodology of FCC's OST/OET Bulletin number 65.
2. Reference levels as given in Annex III, European Directive on the limitation of exposure of the general public to electromagnetic fields (0 Hz to 300 GHz) (1999/519/EC). These distances will ensure indirect compliance with the requirements of EN 50385:2002.

Frequency (MHz)	Maximum Power (dBm) <sup>Note 1</sup>	Maximum Antenna Gain (dBi)	Minimum Separation Distance (m)
915	+ 26	10 dBi	0.3

Note 1: The Peak Envelope Power (PEP) at maximum set power level is 1.0 W ,+30 dBm.



# Contents

<b>1. Getting Started .....</b>	<b>13</b>
<b>2. Introduction.....</b>	<b>15</b>
About This Manual.....	15
What It Covers .....	15
Who Should Read It .....	15
Contact Us.....	15
What's in the Box .....	15
Aprisa SRi Accessory Kit .....	16
Aprisa SRi CD Contents .....	16
Software .....	16
Documentation .....	16
<b>3. About the Radio .....</b>	<b>17</b>
The 4RF Aprisa SRi Radio.....	17
Product Overview .....	18
Network Coverage and Capacity .....	18
Automatic Registration .....	18
Remote Messaging.....	18
Product Features .....	19
Functions .....	19
Security.....	20
Performance .....	21
Usability .....	21
System Gain vs FEC Coding .....	22
Architecture.....	23
Product Operation.....	23
Physical Layer.....	23
Data Link Layer / MAC layer .....	24
Channel Access .....	24
Hop by Hop Transmission.....	25
Adaptive Coding and Modulation .....	25
Network Layer .....	26
Packet Routing.....	26
Static IP Router .....	27
Bridge Mode with VLAN Aware .....	30
VLAN Bridge Mode Description .....	31
Avoiding Narrow Band Radio Traffic Overloading.....	33
Interfaces.....	35
Antenna Interface .....	35
Ethernet Interface .....	35
RS-232 / RS-485 Interface.....	35
USB Interfaces .....	35
Protect Interface .....	35
Alarms Interface.....	35
Front Panel Connections .....	36
LED Display Panel .....	37
Single Radio Software Upgrade.....	38
Network Software Upgrade .....	38
Test Mode .....	39

Network Management.....	40
Hardware Alarm Inputs / Outputs .....	41
Alarm Input to SNMP Trap.....	41
Alarm Input to Alarm Output .....	41
Aprisa SR Alarm Input to Aprisa SRi Alarm Output.....	41
<b>4. Implementing the Network.....</b>	<b>42</b>
Network Topologies .....	42
Point-To-Point Network .....	42
Point-to-Multipoint Network.....	42
Initial Network Deployment .....	43
Install the Base Station .....	43
Installing the Remote Stations .....	43
Network Changes .....	44
Adding a Remote Station .....	44
<b>5. Preparation .....</b>	<b>45</b>
Bench Setup.....	45
Compliance Considerations .....	46
Path Planning .....	48
Antenna Selection and Siting .....	48
Base Station .....	48
Remote station .....	49
Antenna Siting .....	50
Coaxial Feeder Cables .....	51
Linking System Plan .....	51
Site Requirements.....	52
Power Supply.....	52
Equipment Cooling .....	52
Earthing and Lightning Protection .....	53
Feeder Earthing.....	53
Radio Earthing .....	53
<b>6. Installing the Radio .....</b>	<b>54</b>
Mounting.....	54
Required Tools.....	54
DIN Rail Mounting .....	55
Rack Shelf Mounting .....	56
Wall Mounting.....	57
Installing the Antenna and Feeder Cable .....	58
Connecting the Power Supply .....	59
External Power Supplies.....	59
Spare Fuses.....	60
Additional Spare Fuses.....	61

<b>7. Managing the Radio</b>	<b>63</b>
SuperVisor	63
PC Requirements for SuperVisor	64
Connecting to SuperVisor	65
Management PC Connection	66
PC Settings for SuperVisor	67
Login to SuperVisor	71
Logout of SuperVisor	72
SuperVisor Page Layout	73
SuperVisor Menu	75
SuperVisor Menu Access	76
Standard Radio	78
Terminal	78
Radio	89
Serial	106
Ethernet	116
IP	126
QoS	139
Security	161
Maintenance	183
Events	197
Software	208
Monitoring	227
Network Status	246
Command Line Interface	253
Connecting to the Management Port	253
CLI Commands	256
Viewing the CLI Terminal Summary	257
Changing the Radio IP Address with the CLI	257
<b>8. In-Service Commissioning</b>	<b>258</b>
Before You Start	258
What You Will Need	258
Antenna Alignment	259
Aligning the Antennas	259
<b>9. Product Options</b>	<b>260</b>
Country Specific Products	260
USB Serial Ports	261
USB RS-232 / RS-485 Serial Port	261
USB RS-232 / RS-485 operation	261
USB RS-232 Cabling Options	262
USB RS-485 Cabling Options	262
USB Retention Clip	263
<b>10. Maintenance</b>	<b>265</b>
No User-Serviceable Components	265
Software Upgrade	266
Network Software Upgrade	266
Single Radio Software Upgrade	268
File Transfer Method	268
USB Boot Upgrade Method	269
Software Downgrade	269

<b>11. Interface Connections</b> .....	<b>270</b>
RJ45 Connector Pin Assignments.....	270
Ethernet Interface Connections.....	270
RS-232 Serial Interface Connections.....	271
RS-232 Pinout.....	271
RS-232 Customer Cable Wiring.....	271
RS-232 RJ45 LED Indicators.....	271
Alarm Interface Connections.....	272
<b>12. Alarm Types and Sources</b> .....	<b>273</b>
Alarm Types.....	273
Alarm Events.....	274
Informational Events.....	278
<b>13. Specifications</b> .....	<b>279</b>
RF Specifications.....	279
Frequency Bands.....	279
Channel Sizes.....	279
Receiver.....	280
Transmitter.....	282
Spread Spectrum.....	282
Modem.....	283
Data Payload Security.....	283
Interface Specifications.....	284
Ethernet Interface.....	284
RS-232 Asynchronous Interface.....	285
Hardware Alarms Interface.....	286
Power Specifications.....	287
Power Supply.....	287
Power Consumption.....	287
Power Dissipation.....	287
General Specifications.....	288
Environmental.....	288
Mechanical.....	288
Compliance.....	289
<b>14. Product End Of Life</b> .....	<b>290</b>
End-of-Life Recycling Programme (WEEE).....	290
The WEEE Symbol Explained.....	290
WEEE Must Be Collected Separately.....	290
YOUR ROLE in the Recovery of WEEE.....	290
EEE Waste Impacts the Environment and Health.....	290
<b>15. Copyrights</b> .....	<b>291</b>
<b>16. Abbreviations</b> .....	<b>293</b>
<b>17. Index</b> .....	<b>294</b>

# 1. Getting Started

This section is an overview of the steps required to commission an Aprisa SRi radio network in the field:

<b>Phase 1:</b>	<b>Pre-installation</b>	
1.	Confirm path planning.	Page 48
2.	Ensure that the site preparation is complete: <ul style="list-style-type: none"> <li>• Power requirements</li> <li>• Tower requirements</li> <li>• Environmental considerations, for example, temperature control</li> <li>• Mounting space</li> </ul>	Page 51

<b>Phase 2:</b>	<b>Installing the radios</b>	
1.	Mount the radio.	Page 54
2.	Connect earthing to the radio.	Page 53
3.	Confirm that the: <ul style="list-style-type: none"> <li>• Antenna is mounted and visually aligned</li> <li>• Feeder cable is connected to the antenna</li> <li>• Feeder connections are tightened to recommended level</li> <li>• Tower earthing is complete</li> </ul>	
4.	Install lightning protection.	Page 53
5.	Connect the coaxial jumper cable between the lightning protection and the radio antenna port.	Page 58
6.	Connect the power to the radio.	Page 59

<b>Phase 3:</b>	<b>Establishing the link</b>	
1.	If radio's IP address is not the default IP address (169.254.50.10 with a subnet mask of 255.255.0.0) and you don't know the radio's IP address see 'Command Line Interface' on page 253.	Page 253
2.	Connect the Ethernet cable between the radio's Ethernet port and the PC.	
3.	Confirm that the PC IP settings are correct for the Ethernet connection: <ul style="list-style-type: none"> <li>• IP address</li> <li>• Subnet mask</li> <li>• Gateway IP address</li> </ul>	Page 67
4.	Open a web browser and login to the radio.	Page 71
5.	Set or confirm the RF characteristics: <ul style="list-style-type: none"> <li>• TX / RX frequency</li> <li>• TX output power</li> <li>• Zone / channel selection</li> </ul>	Page 101
6.	Compare the actual RSSI to the expected RSSI value (from your path planning).	Page 235
7.	Align the antennas.	Page 259
8.	Confirm that the radio is operating correctly; the OK, MODE and AUX LEDs are green.	



## 2. Introduction

### About This Manual

#### What It Covers

This user manual describes how to install and configure an Aprisa SRi point-to-multipoint digital radio network.

It specifically documents an Aprisa SRi radio running system software version 1.0.0 .

It is recommended that you read the relevant sections of this manual before installing or operating the radios.

#### Who Should Read It

This manual has been written for professional field technicians and engineers who have an appropriate level of training and experience.

### Contact Us

If you experience any difficulty installing or using Aprisa SRi after reading this manual, please contact Customer Support or your local 4RF representative.

Our area representative contact details are available from our website:

4RF Limited  
26 Glover Street, Ngauranga  
PO Box 13-506  
Wellington 6032  
New Zealand

E-mail	<a href="mailto:support@4rf.com">support@4rf.com</a>
Web site	<a href="http://www.4rf.com">www.4rf.com</a>
Telephone	+64 4 499 6000
Facsimile	+64 4 473 4447
Attention	Customer Services

### What's in the Box

Inside the box you will find:

- One Aprisa SRi radio fitted with a power connector.
- One Aprisa SRi Accessory kit containing the following:
  - Aprisa SRi CD
  - Aprisa SRi Quick Start Guide
  - Management Cable

## Aprisa SRi Accessory Kit

The accessory kit contains the following items:

Aprisa SRi Quick Start Guide



Aprisa SRi CD



Management Cable

USB Cable USB A to USB micro B, 1m



## Aprisa SRi CD Contents

The Aprisa SRi CD contains the following:

### Software

- The latest version of the radio software (see 'Software Upgrade' on page 266)
- USB Serial Driver
- Web browsers - Mozilla Firefox and Internet Explorer are included for your convenience
- Adobe™ Acrobat® Reader® which you need to view the PDF files on the Aprisa SRi CD

### Documentation

- User manual - an electronic (PDF) version for you to view online or print
- Product collateral - application overviews, product description, quick start guide, case studies, software release notes and technical papers

### 3. About the Radio

#### The 4RF Aprisa SRi Radio

The 4RF Aprisa SRi is a Point-To-Multipoint (PMP) digital radio providing 915 MHz Industrial Licence Free Spread Spectrum communications.

The radios carry a combination of serial data and Ethernet data between the base station and remote stations.

A single Aprisa SRi is configurable as a Point-To-Multipoint base station or remote station.



## Product Overview

### Network Coverage and Capacity

The Aprisa SRi has a typical link range of up to 50 km, however, geographic features, such as hills, mountains, trees and foliage, or other path obstructions, such as buildings, will limit radio coverage. Additionally, geography may reduce network capacity at the edge of the network where errors may occur and require retransmission. However, the Aprisa SRi uses 0.4 W (+26 dBm) output power and Forward Error Correction (FEC) which greatly improves the sensitivity and system gain performance of the radio resulting in less retries and minimal reduction in capacity.

Ultimately, the overall performance of any specific network will be defined by a range of factors including the RF output power, the modulation used and its related receiver sensitivity, the geographic location, the number of remote stations in the base station coverage area and the traffic profile across the network. Effective network design will distribute the total number of remote stations across the available base stations to ensure optimal geographic coverage and network capacity.

One base station can register and operate with up to 500 remote stations.

The practical limit of remote stations that can operate with one base station is determined by a range of factors including the number of services, the packet sizes, the protocols used, the message types and network timeouts.

### Automatic Registration

On start-up, the remote station listens for the base station before attempting registration. It then transmits a registration message to the base station which responds with a registration response. The base station records the details of all the remote stations active in the network.

If a remote station cannot register with the base station after multiple attempts within 10 minutes, it will automatically reboot. If remote is not able to register with base station in 5 attempts, then a 'Network Configuration Warning' alarm event will be raised indicating that a remote is not registered with the base station.

If a remote station has registered with the base station but then loses communication, it will automatically reboot within 2 minutes.

### Remote Messaging

There are two message types in the Aprisa SRi network, broadcast messages and unicast messages. Broadcast messages are transmitted by the base station to the remote stations and unicast messages are transmitted by the remote station to the base station. These messages are commonly referred to as uplink (unicast remote to base) and downlink (broadcast base to remote).

All remotes within the coverage area will receive broadcast messages and pass them on to either the Ethernet or serial interface. The RTU determines if the message is intended for it and will accept it or discard it.

# Product Features

## Functions

- Point-to-Multipoint (PMP) operation
- Unlicensed frequency bands in the frequency range of 902-928 MHz as permitted by the local regulator
- Channel size of 50 kHz
- Half duplex RF Point-To-Multipoint operation
- Military style jam resistant frequency hopping spread spectrum technology operating where other licence free radios have difficulty in break through
- Full band and reduced non-overlapping zone options allow a tailored approach to interference management for maximum range
- Ethernet data interface and RS-232 / RS-485 asynchronous
- Data encryption and authentication using 128,192 and 256 bit AES and CCM security standards
- Terminal server operation for transporting RS-232 / RS-485 traffic over IP or Ethernet and converting IP packets to a local physical serial port
- SLIP support for RS-232
- IEEE 802.1Q VLAN support with single and double VLAN tagged and add/remove VLAN manipulation to adapt to the appropriate RTU / PLCs
- QoS supports using IEEE 802.1p VLAN priority bits to prioritize and handle the VLAN / traffic types
- QoS per port (Ethernet, serial, management)
- L2 / L3 / L4 filtering for security and avoiding narrow band radio network overload
- L3 Gateway Router mode with standard static IP route for simple routing network integration
- L3 Router mode with per Ethernet interface IP address and subnet
- L2 Bridge mode with VLAN aware for standard Industrial LAN integration
- Ethernet and serial payload compression to increase the narrow band radio capacity
- SuperVisor web management support for element and sub-network management
- SNMPv1/2/3 & encryption MIB supports for 4RF SNMP manager or third party SNMP agent network management
- SNMP context addressing for compressed SNMP access to remote stations
- SNTP for accurate wide radio network time and date
- RADIUS security for remote user authorization, authentication and accounting
- Transparent to all common SCADA protocols; e.g. Modbus, IEC 60870-5-101/104, DNP3 or similar
- Complies with international standards, including FCC, EMC, safety and environmental standards

## Security

The Aprisa SRi provides security features to implement the key recommendations for industrial control systems. The security provided builds upon the best in class from multiple standards bodies, including:

- IEC/TR 62443 (TC65) 'Industrial Communications Networks - Network and System Security'
- IEC/TS 62351 (TC57) 'Power System Control and Associated Communications - Data and Communication Security'
- FIPS PUB 197, NIST SP 800-38C, IETF RFC3394, RFC3610 and IEEE P1711/P1689/P1685
- FIPS 140-2: Security Requirements for Cryptographic Modules

The security features implemented are:

- Data encryption
  - Counter Mode Encryption (CTR) using Advanced Encryption Standard (AES) 128, 192, 256 bit, based on FIPS PUB 197 AES encryption (using Rijndael version 3.0)
- Data authentication
  - NIST SP 800-38C Cipher Block Chaining Message Authentication Code (CBC-MAC) based on RFC 3610 using Advanced Encryption Standard (AES)
- Data payload security
  - CCM Counter with CBC-MAC integrity (NIST special publication 800-38C)
- Secured management interface protects configuration
- L2 / L3 / L4 Address filtering enables traffic source authorization
- Proprietary physical layer protocol and modified MAC layer protocol based on standardized IEEE 802.15.4
- SNMPv3 with Encryption for NMS secure access
- Secure USB software upgrade
- Key Encryption Key (KEK) based on RFC 3394, for secure Over The Air Re-keying (OTAR) of encryption keys
- User privilege allows the accessibility control of the different radio network users and the user permissions

## Performance

- Typical deployment of 30 remote stations from one base station with a practical limit of a few hundred remote stations
- Low noise receiver
- Forward Error Correction
- Electronic tuning over the frequency band
- Thermal management for high power over a wide temperature range

## Usability

- Configuration / diagnostics via front panel Management Port USB interface, Ethernet interface
- Built-in webserver SuperVisor with full configuration, diagnostics and monitoring functionality, including remote station configuration / diagnostics over the radio link
- LED display for on-site diagnostics
- Dedicated alarm port
- Software upgrade and diagnostic reporting via the host port USB flash drive
- Over-the-air software distribution and upgrades
- Simple installation with integrated mounting holes for wall, DIN rail and rack shelf mounting

## System Gain vs FEC Coding

Minimum FEC coding results in lower system gain, lower coverage but higher capacity.

This table defines the modulation order based on gross capacity:

Modulation	FEC Coding	Capacity
QPSK (Low Gain)	Min Coded FEC	Minimum
16QAM (Low Gain)	Min Coded FEC	↓
64QAM (Low Gain)	Min Coded FEC	Maximum

This table defines the modulation order based on receiver sensitivity:

Modulation	FEC Coding	Coverage
QPSK (Low Gain)	Min Coded FEC	Maximum
16QAM (Low Gain)	Min Coded FEC	↑
64QAM (Low Gain)	Min Coded FEC	Minimum



## Architecture

The Aprisa SRi Architecture is based around a layered TCP/IP protocol stack:

- Physical
  - Proprietary wireless
  - RS-232 and Ethernet interfaces
- Link
  - Proprietary wireless (channel access, ARQ, segmentation)
  - VLAN aware Ethernet bridge
- Network
  - Standard IP
  - Proprietary automatic radio routing table population algorithm
- Transport
  - TCP, UDP
- Application
  - HTTPS web management access through base station with proprietary management application software including management of remote stations over the radio link
  - SNMPv1/2/3 for network management application software

## Product Operation

There are three components to the wireless interface: the Physical Layer (PHY), the Data Link Layer (DLL) and the Network Layer. These three layers are required to transport data across the wireless channel in the Point-to-Multipoint (PMP) configuration. The Aprisa SRi DLL is largely based on the 802.15.4 Media Access Control (MAC) layer using a proprietary implementation.

## Physical Layer

The Aprisa SRi PHY uses a one frequency half duplex transmission mode which eliminates the need for a duplexer.

Remote nodes are predominantly in receive mode with only sporadic bursts of transmit data. This reduces power consumption.

The Aprisa SRi is a packet based radio. Data is sent over the wireless channel in discrete packets / frames, separated in time. The PHY demodulates data within these packets with coherent detection.

The Aprisa SRi PHY provides carrier, symbol and frame synchronization predominantly through the use of preambles. This preamble prefixes all packets sent over the wireless channel which enables fast Synchronization.

## Data Link Layer / MAC layer

The Aprisa SRi PHY enables multiple users to be able to share a single wireless channel; however a DLL is required to manage data transport. The two key components to the DLL are channel access and hop by hop transmission.

### Channel Access

The Aprisa SRi radio uses a channel access of Access Request. Channel access scheme where the base stations controls the communication on the channel. Remotes ask for access to the channel, and the base station grants access if the channel is not occupied.

#### Access Request

This scheme is particularly suited to digital SCADA systems where all data flows through the base station. In this case it is important that the base station has contention-free access as it is involved in every transaction. The channel access scheme assigns the base station as the channel access arbitrator and therefore inherently it has contention-free access to the channel. This means that there is no possibility of contention on data originating from the base station. As all data flows to or from the base station, this significantly improves the robustness of the system.

All data messages are controlled via the AG (access grant) control message and therefore there is no possibility of contention on the actual end user data. If a remote station accesses the channel, the only contention risk is on the AR (access request) control message. These control messages are designed to be as short as possible and therefore the risk of collision of these control messages is significantly reduced. Should collisions occur these are resolved using a random back off and retry mechanism.

As the base station controls all data transactions multiple applications can be effectively handled, including a mixture of polling and report by exception.

## Hop by Hop Transmission

Hop by Hop Transmission is realized in the Aprisa SRi by adding a MAC address header to the packet. For 802.15.4, there are 2 addresses, the source and destination addresses.

## Adaptive Coding and Modulation

The Aprisa SRi provides Adaptive Coding and Modulation (ACM) which maximizes the use of the RF path to provide the highest radio capacity available.

ACM automatically adjusts the modulation coding and FEC code rate in the remote to base direction of transmission over the defined modulation range based on the signal quality for each individual remote radio.

When the RF path is healthy (no fading), modulation coding is increased and the FEC code rate is decreased to maximize the data capacity.

If the RF path quality degrades, modulation coding is decreased and the FEC code rate is increased for maximum robustness to maintain path connectivity.

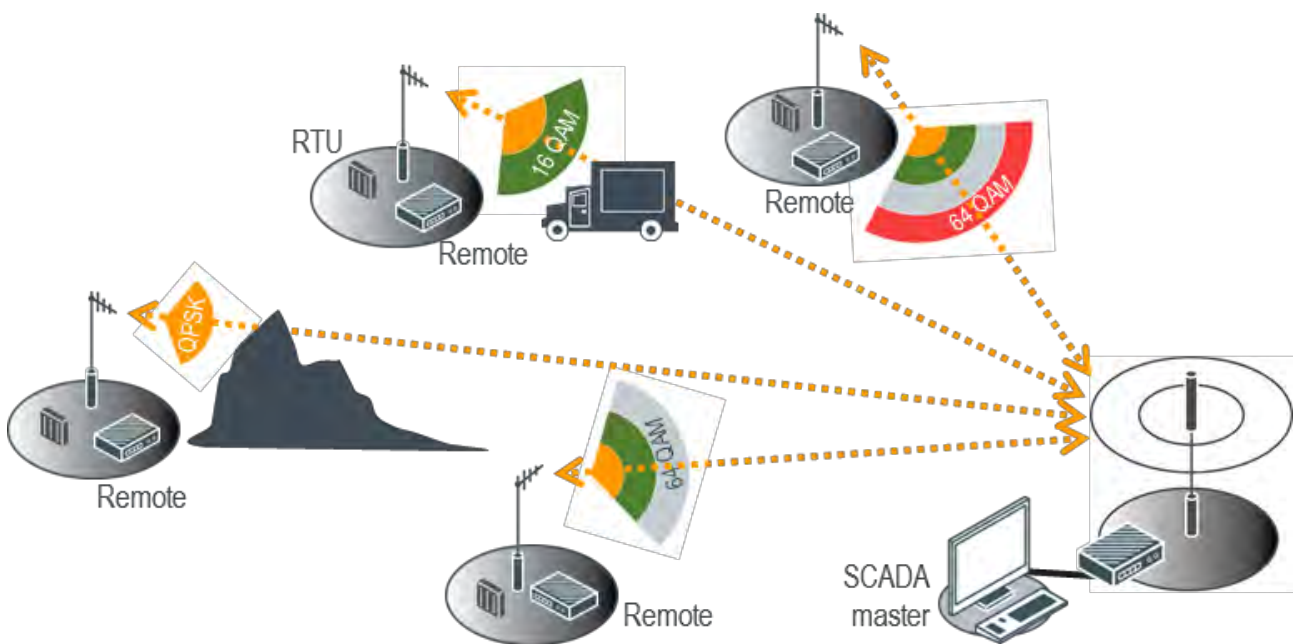

## Network Layer

### Packet Routing

Aprisa SRi is a standard static IP router which routes and forwards IP packet based on standard IP address and routing table decisions.

Aprisa SRi router mode (see figure below), enables the routing of IP packets within the Aprisa SRi wireless network and in and out to the external router / IP RTUs devices connected to the Aprisa SRi wired Ethernet ports.

Within the Aprisa SRi Router mode, each incoming Ethernet packet on the Ethernet port is stripped from its Ethernet header to reveal the IP packet and to route the IP packet based on its routing table. If the destination IP address is one of the RTUs, the packet is then forwarded to the wireless ports and broadcasted as a PMP wireless packet to all the remote stations. The appropriate remote then routes the IP packet and forwards it based on its routing table to the appropriate Ethernet port, encapsulating the appropriate next hop MAC header and forwarding it to the RTU. The RTU can then interpret and process the IP data and communication is established between the RTU and the initiating communication device.

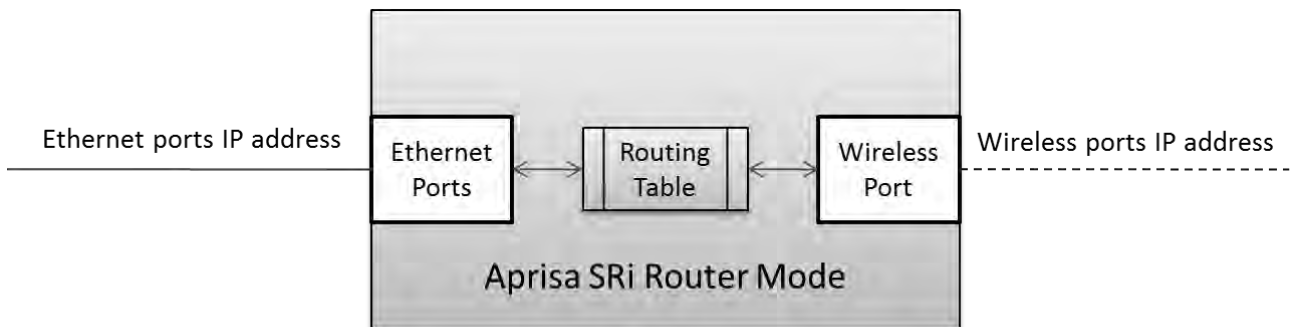

## Static IP Router

The Aprisa SRi works in the point-to-multipoint (PMP) network as a standard static IP router with the Ethernet and wireless / radio as interfaces and serial ports using terminal server as a virtual interface.

The Aprisa SRi static router is semi-automated operation, where the routing table is automatically created in the base station and populated with routes to all remote stations in the network during the registration process and vice versa, where the routing table is automatically created in remote stations and populated with routes to base station during the registration process. Updates occur when remote is disconnected from network for any reason, with the routing table updated in a controlled fashion.

Also, in decommission operation, the base station routing tables are completely flushed allowing an automatic rebuild. This avoids the user manually inserting / removing of multiple static routes to build / change the routes in the network which might be tedious and introduce significant human error. The Aprisa SRi works as a static IP router without using any routing protocol and therefore does not have the overhead of a routing protocol for better utilization of the narrow bandwidth network.

In addition to the semi-automated routes, the user can manually add / remove routes in the routing table for the radio interface, Ethernet Interface and for routers which are connected to the radio network.

The Aprisa SRi base station is used as a gateway to other networks. Thus, a configurable IP address default gateway can be set using a static route in the routing table with a destination IP address of the destination network address. It is recommended to use a real network IP address (actual device IP) for the gateway and not 0.0.0.0.

The Aprisa SRi sub-netting rules distinguish between the wireless interface and the remote Ethernet interface where RTUs are connected. The entire wireless network is set on a single IP subnet, while each Aprisa SRi remote's Ethernet interface is set to a different subnet network. In this way, the user can easily distinguish between the remotes subnet IP addresses.

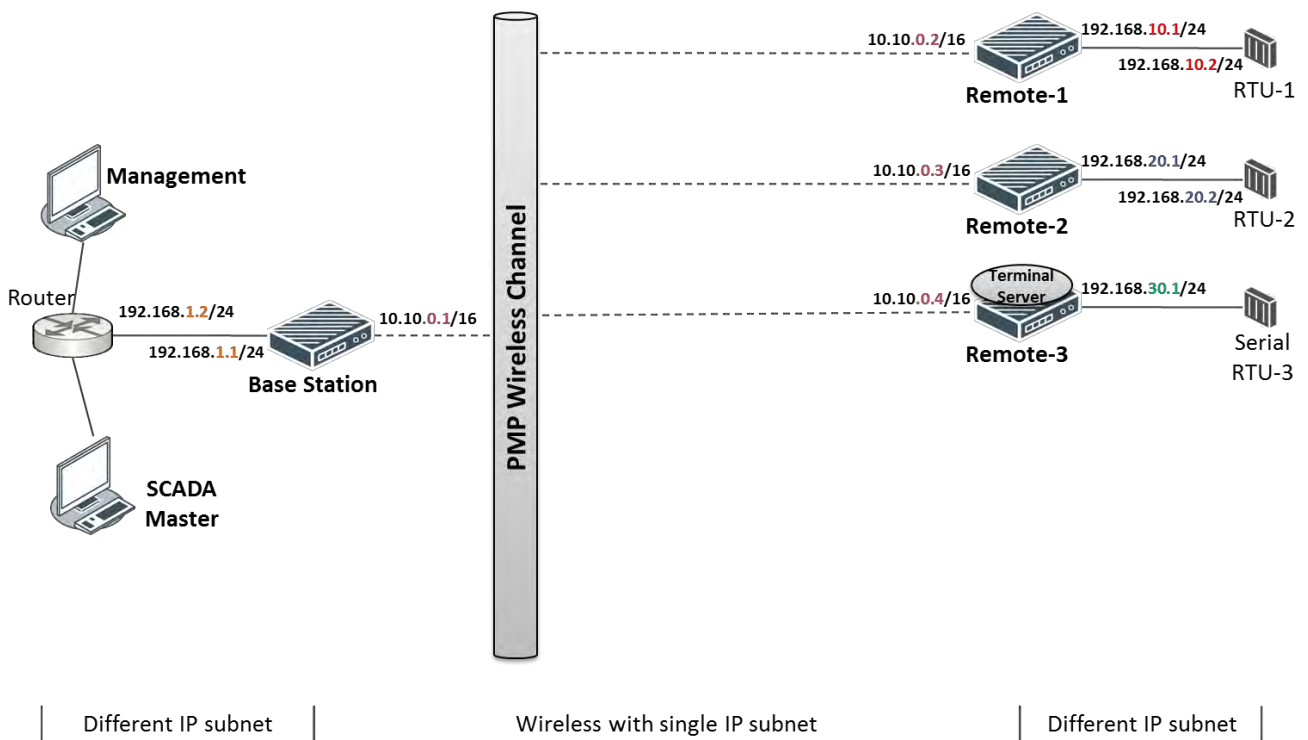

## The Radio Network as a Gateway Router

The Aprisa SRi point-to-multipoint radio network can be considered as a gateway router where the ‘network Ethernet interface’ on each radio in the network is the ‘router port’.

The routing table for all directly attached devices to the Aprisa SRi network, at the Base or the Remote stations is automatically built and no static routes are required to be entered for those device routes.

The ‘Radio interface IP address’ is used internally for the radio network and automatic routes. It is not used when setting static routes or default gateways.

Static route IP addresses or the default gateway should use the ‘network Ethernet interface’ IP address.

External network routers should be set with a high metric for the SRi path, to prevent route updates being sent over the radio network.

## The Radio Network as a Router - Example

The purpose of this example is to determine the static route setting for router R2 in the base station and remote station in the following network.

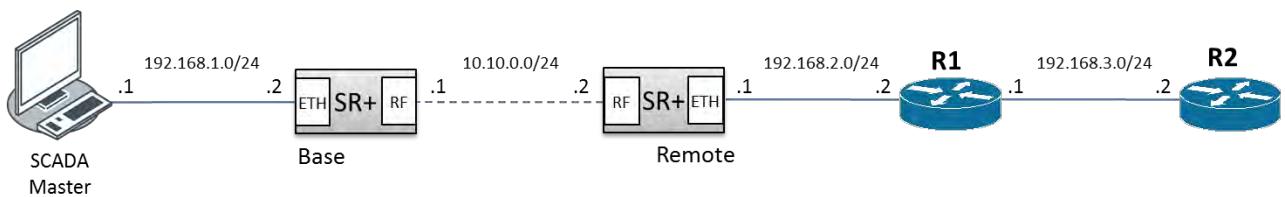

Since the Aprisa SRi network should be considered as a router where the network Ethernet interface is the ‘router port’, the network configuration for setting the static routes or the default gateway IP addresses is described in the follow figure:

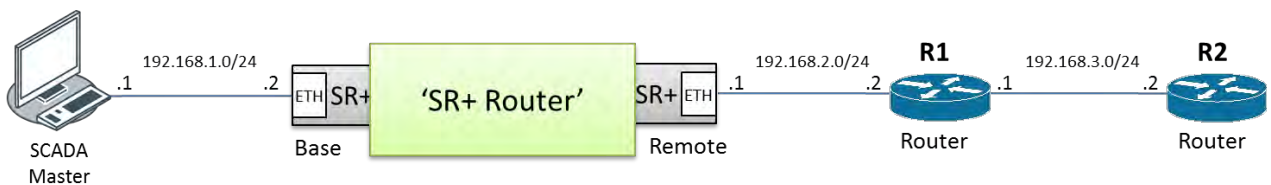

Thus, the static route setting for router R2 at the Aprisa SRi base station and remote station will be:

Destination Address	Destination Mask	Gateway Address	Static Route Setting at ?
192.168.3.0	255.255.255.0	192.168.2.1	Base station
192.168.3.0	255.255.255.0	192.168.2.2	Remote station

**Note:** The radio network (base station and remote stations) will automatically build routes to the attached device e.g. SCADA Master station or attached router e.g. router R1 so static routes are not required for these devices.

## Static IP Router - Human Error Free

To ensure correct operation, the Aprisa SR router base station alerts when one (or more) of the devices is not configured for router mode or a duplicated IP is detected when manually added.

When the user changes the base station IP address / subnet, the base station sends an ARP unsolicited announcement message and the remote stations auto-update their routing table accordingly. This also allows the router that is connected to the base station to update its next hop IP address and its routing table.

When the user changes the remote station IP address / subnet, a re-registration process in the base station then auto-updates its routing table accordingly.

## Terminal Server - Transition to Converged Ethernet / IP Network

Customers that are transitioning their SCADA network to an Ethernet / IP SCADA network, can simultaneously operate their legacy serial RTUs, not as a separate serial network to the new Ethernet / IP network, but as part of the Ethernet / IP network, by using the terminal server feature.

The Aprisa SR terminal server is an application running in the radio that encapsulates serial traffic into Ethernet / IP traffic. For SCADA networks, this enables the use of both serial and Ethernet / IP RTUs within an Ethernet / IP based SCADA network.

## Bridge Mode with VLAN Aware

### Ethernet VLAN Bridge / Switch Overview

The Aprisa SRi in Bridge mode of operation is a standard Ethernet Bridge based on IEEE 802.1d or VLAN Bridge based on IEEE 802.1q/p which forward / switch Ethernet packet based on standard MAC addresses and VLANs using FDB (forwarding database) table decisions. VLAN is short for Virtual LAN and is a virtual separate network, within its own broadcast domain, but across the same physical network.

VLANs offer several important benefits such as improved network performance, increased security and simplified network management.

The Aprisa SRi Bridge mode (see figure below), is the default mode of operation and it enables the switching / bridging of Ethernet VLAN tagged or untagged packets within the Aprisa SRi wireless network and in and out to the external Industrial LAN network and RTUs devices connected to the Aprisa SRi wired Ethernet ports or serial ports through the terminal server function.

Within the Aprisa SRi Bridge mode, each incoming Ethernet packet is inspected for the destination MAC address (and VLAN) and looks up its FDB table for information on where to send the specific Ethernet frame. If the FDB table doesn't contain the specific MAC address, it will flood the Ethernet frame out to all ports in the broadcast domain and when using VLAN, the broadcast domain is narrowed to the specific VLAN used in the packet (i.e. broadcast will be done only to the ports which configured with that specific VLAN).

The FDB table is used to store the MAC addresses that have been learnt and the ports associated with that MAC address. If the destination MAC address is one of the RTUs, the packet is then forwarded to the wireless ports and broadcast as a PMP wireless packet to all the remote stations. The appropriate remote then switches the Ethernet packet and forwards it based on its FDB table (based on the MAC or VLAN & MAC) to the appropriate Ethernet port to the RTU. The RTU can then interpret and process the Ethernet / IP data and communication is established between the RTU and the initiating communication device.

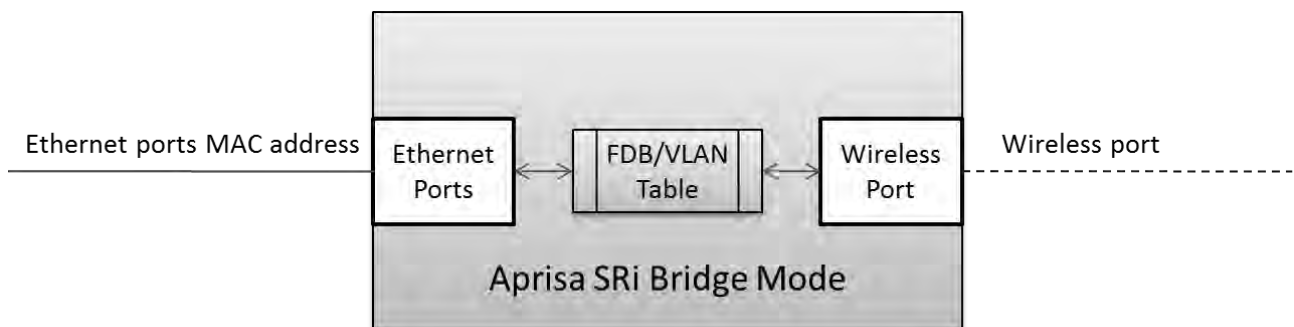



## VLAN Bridge Mode Description

### General - Aprisa SRi VLAN Bridge

The Aprisa SRi works in a point-to-multipoint (PMP) network as a standard VLAN bridge with the Ethernet and wireless / radio as interfaces and serial ports using terminal server as a virtual interface.

The Aprisa SRi is a standard IEEE 802.1q VLAN bridge, where the FDB table is created by the bridge learning / aging process. New MACs are learnt and the FDB table updated. Unused MACs are aged out and flushed automatically after aging period.

VLANs are statically configured by the user on the ports where a Virtual LAN is required across the radio network. An example of VLAN isolation of traffic type is shown in the figure below, where RTUs #1, 4 and 6 together with SCADA meter master form a Virtual LAN which is isolated from the other devices, even though they are on the same physical network. VLAN management can be used to manage with external NMS all the Aprisa SRi devices on the radio network and is automatically created with a VLAN ID = 1 default value. The VLAN ID can be changed by the user later on.

Each device in the Aprisa SRi bridge is identified by its own IP address, as shown in the figure.

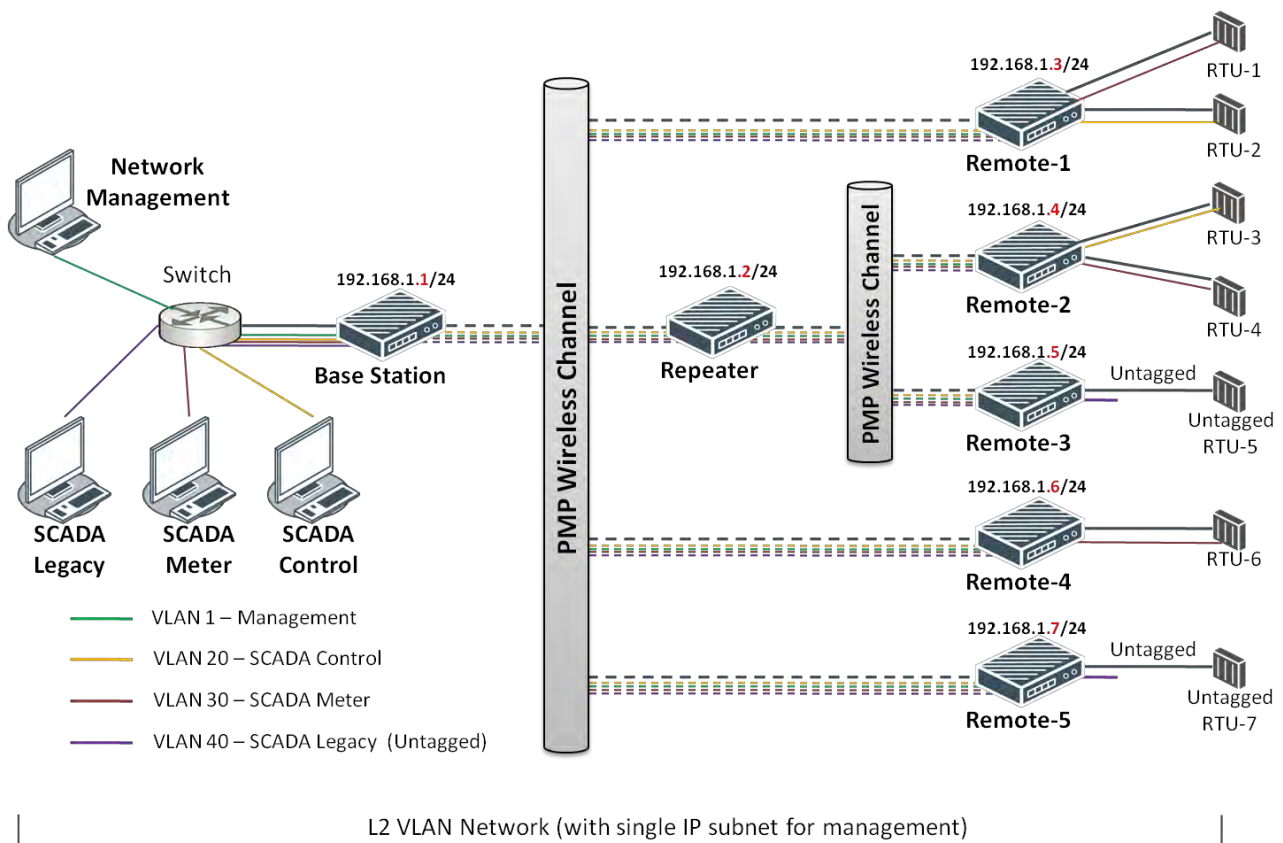

## VLANs - Single, Double and Trunk VLAN ports

The Aprisa SRi supports single VLAN (CVLAN), double VLAN (SVLAN) and trunk VLAN.

A single VLAN can be used to segregate traffic type.

A double VLAN can be used to distinguish between Aprisa SRi sub-networks (remotes), where the outer SVLAN is used to identify the sub-network and the CVLAN is used to identify the traffic type. In this case, a double tagged VLAN will be forwarded across the Industrial LAN network and switched based on the SVLAN to the appropriate Aprisa SRi sub-network. When packet enters the Aprisa SRi network, the SVLAN will be stripped off (removed) and the forwarding will be done based on the CVLAN, so only a single VLAN will pass through over the radio network and double VLAN will be valid on the borders of the radio network.

Trunk VLAN is also supported by the Aprisa SRi where the user can configure multiple VLANs on a specific Ethernet port, creating a trunk VLAN port. For example, in the above figure, a single trunk VLAN port is created between the switch and the Aprisa SRi base station, carrying VLAN ID #1, 20, 30 and 40.

## VLAN Manipulation - Add / Remove VLAN Tags

In order to support double VLAN and different device types connected to the Aprisa SRi e.g. switches, RTUs, etc, which can be VLAN tagged or untagged / plain Ethernet devices, add / remove VLAN manipulation is required.

In an Aprisa SRi VLAN tagged network, a remote Aprisa SRi connected to a plain RTU without VLAN support, will remove (strip-off) the VLAN tag from the packet before sending it to the RTU. On the other direction, when the RTU is sending an untagged packet, the Aprisa SRi will add (append) an appropriate user pre-configure VLAN tag before sending it over the air to the base station. This is shown in the above figure on untagged RTU #5 and 7.

## QoS using VLAN

VLANs carry 3 priority bits (PCP field) in the VLAN tag allowing prioritization of VLAN tagged traffic types with 8 levels of priority (where 7 is the highest priority and 0 is the lowest priority). The Aprisa SRi supports QoS (Quality of Service) where the priority bits in the VLAN tagged frame are evaluated and mapped to four priority levels and four queues supported by the Aprisa SRi radio. Packets in the queues are then scheduled out in a strict priority fashion for transmission over-the-air as per the priority level from high to low.

## Avoiding Narrow Band Radio Traffic Overloading

The Aprisa SRi supports mechanisms to prevent narrowband radio network overload:

### 1. L3/L4 Filtering

The L3 filtering can be used to block undesired traffic from being transferred on the narrow band channel, occupying the channel and risking the SCADA critical traffic. L3/4 filtering has the ability to block a known IP address and applications using TCP/IP or UDP/IP protocols with multiple filtering rules. The L3 (/L4) filter can block/forward (discard/process) a specific IP address and a range of IP addresses. Each IP addressing filtering rule set can also be set to filter a L4 TCP or UDP port/s which in most cases relates to specific applications as per IANA official and unofficial well-known ports. For example, filter and block E-mail SMTP or TFTP protocol as undesired traffic over the SCADA network. The user can block a specific or range of IP port addresses, examples SMTP (Simple Mail Transfer Protocol) TCP port 25 or TFTP (Simple Trivial File Transfer Protocol) UDP port 69.

### 2. L2 Address Filtering

L2 Filtering (Bridge Mode) provides the ability to filter radio link traffic based on specified Layer 2 MAC addresses. Destination MAC (DA) addresses and a Source MAC (SA) addresses and protocol type (ARP, VLAN, IPv4, IPv6 or Any type) that meet the filtering criteria will be transmitted over the radio link. Traffic that does not meet the filtering criteria will not be transmitted over the radio link.

### 3. L2 Port VLANs Ingress Filtering and QoS

#### Double VLAN (Bridge Mode)

Double VLAN is used to distinguish/segregate between different radio sub-networks (remotes). Traffic with double VLANs which are not destined to a specific sub-network will be discarded on the ingress of the radio sub-network, avoiding the overload of the radio sub-network.

#### Single VLAN (Bridge Mode)

Single VLAN is used to distinguish/segregate between different traffic types assigned by the user in its industrial corporate LAN. In order to avoid the overload of the radio network, traffic with single VLANs which are not destined to a specific radio network will be discarded on the Ethernet ingress port of the radio network. All single VLANs which set and are eligible will be transmitted over the radio link.

#### QoS using 802.1p priority bits (Bridge Mode)

The priority bits can be used in the VLAN tagged frames to prioritize critical mission SCADA traffic and ensure SCADA traffic transmission relative to any other unimportant traffic. In this case, traffic based on VLAN priority (priority 0 to 7) enters one of the four priority queues of the Aprisa SRi (Very High, High, Medium and Low). Traffic leaves the queues (to the radio network) from highest priority to lowest in a strict priority fashion.

### 4. Ethernet port QoS

The Aprisa SRi supports 'Ethernet Per Port Prioritization'. Each Ethernet port can be assigned a priority and traffic shall be prioritized accordingly. This is quite useful in networks where customers do not use VLANs or cannot use 802.1p prioritization.

#### 5. Ethernet Data and Management Priority and Background Bulk Data Transfer Rate

Alternatively to VLAN priority, users can control the Ethernet traffic priority (vs serial), management priority and rate in order to control the traffic load of the radio network, where important and high priority data (SCADA) will pass-through first assuring SCADA network operation. The user can set the use of the Ethernet Data Priority, which controls the priority of the Ethernet customer traffic relative to the serial customer traffic and can be set to one of the four queues. The Ethernet Management Priority controls the priority of the Ethernet management traffic relative to Ethernet customer traffic and can be set to one of the four queues. The Background Bulk Data Transfer Rate sets the data transfer rate (high, medium, low) for large amounts of management data.

#### 6. Ethernet Packet Time to Live

Another aspect of avoiding overload radio network is the Ethernet packet TTL, which is used to prevent old, redundant packets being transmitted through the radio network. This sets the time an Ethernet packet is allowed to live in the system before being dropped if it cannot be transmitted over the air.

#### 7. Payload Compression

Aprisa SRi supports payload compression. A Lempel-Ziv (LZ) algorithm is used to efficiently compress up to 50% traffic with high percentage of repetitive strings. Both serial and Ethernet / IP payload traffic are compressed.

## Interfaces

### Antenna Interface

- 1 x TNC, 50 ohm, female connector

### Ethernet Interface

- 2 ports 10/100 base-T Ethernet layer 2 switch using RJ45  
Used for Ethernet user traffic and radio sub-network management.

### RS-232 / RS-485 Interface

- 1 port RS-232 asynchronous ports using RJ45 connector
- Optional 1x RS-232 or RS-485 asynchronous port using USB host port with USB to RS-232 or USB to RS-485 converters

### USB Interfaces

- 1 x Management port using USB micro type B connector  
Used for product configuration with the Command Line Interface (CLI).
- 1 x Host port using USB standard type A connector  
Used for software upgrade, diagnostic reporting and configuration save / restore.

### Protect Interface

- 1x Protect interface port  
Not Used.

### Alarms Interface

- 1x Alarm port using RJ45 connector  
Used to provide 2 x hardware alarm inputs and 2 x hardware alarm outputs

## Front Panel Connections



All connections to the radio are made on the front panel. The functions of the connectors are (from left to right):

Designator	Description
10 - 30 VDC; 3A	+10 to +30 VDC (negative ground) DC power input using Molex 2 pin male screw fitting connector. AC/DC and DC/DC power supplies are available as accessories. See 'External Power Supplies' on page 59.
ETHERNET 1 & 2	Integrated 10Base-T/100Base-TX layer-3 Ethernet switch using RJ45 connectors. Used for Ethernet user traffic and product management. See 'Ethernet > Port Setup' on page 117.
SERIAL 1	One port of RS-232 serial using RJ45 connector. Used for RS-232 asynchronous user traffic. See 'Serial > Port Setup' on page 108.
	Host Port using a USB standard type A connector. Used for software upgrade and diagnostic reporting and optional: 1x RS-232 asynchronous port with USB to RS-232 converter. See 'Software Upgrade' on page 266 and 'Maintenance > General' on page 185.
ALARM	Alarm Port using a RJ45 connector. Used for two alarm inputs and two alarm outputs. See 'Hardware Alarms Interface' on page 286.
MGMT	Management Port using a USB micro type B connector. Used for product configuration with the Command Line Interface. See 'Connecting to the Management Port' on page 253.
PROTECT	Protect port. Not used for the SRi.
ANT	TNC, 50 ohm, female connector for connection of antenna feeder cable for half duplex RF operation. See 'Coaxial Feeder Cables' on page 51.

## LED Display Panel

The Aprisa SRi has an LED Display panel which provides on-site alarms / diagnostics without the need for PC.



The LEDs indicate the following conditions:

	OK	MODE	AUX	TX	RX
<b>Flashing Red</b>		<i>Radio has not registered</i>			
<b>Solid Red</b>	<i>Alarm present with severity Critical, Major and Minor</i>			<i>TX path fail</i>	<i>RX path fail</i>
<b>Flashing Orange</b>		<i>Diagnostics Function Active OTA software distribution</i>	<i>Management traffic on the USB MGMT port</i>		
<b>Solid Orange</b>	<i>Alarm present with Warning Severity</i>		<i>Device detect on the USB host port (momentary)</i>		
<b>Flashing Green</b>	<i>Software Upgrade Successful</i>		<i>Tx / Rx Data on the USB host port</i>	<i>RF path TX is active</i>	<i>RF path RX is active</i>
<b>Solid Green</b>	<i>Power on and functions OK and no alarms</i>	<i>Processor Block is OK</i>	<i>USB interface OK</i>	<i>Tx path OK</i>	<i>Rx path OK</i>

LED Colour	Severity
Green	No alarm - information only
Orange	Warning alarm
Red	Critical, major or minor alarm

## Single Radio Software Upgrade

During a radio software upgrade, the LEDs indicate the following conditions:

- Software upgrade started - the OK LED flashes orange
- Software upgrade progress indicated by running AUX to MODE LEDs
- Software upgrade completed successfully - the OK LED flashes green
- Software upgrade failed - any LED flashing red during the upgrade

## Network Software Upgrade

During a network software upgrade, the MODE LED flashes orange on the base station and all remote stations.



## Test Mode

Remote station radios have a Test Mode which presents a real time visual display of the RSSI on the LED Display panel. This can be used to adjust the antenna for optimum signal strength.

To enter Test Mode, press and hold the TEST button on the radio LED panel until all the LEDs flash green (about 3 - 5 seconds). The response time is variable and can be up to 5 seconds.

To exit Test Mode, press and hold the TEST button until all the LEDs flash red (about 3 - 5 seconds).

---

**Note:** Test Mode traffic has a low priority but could affect customer traffic depending on the relative priorities setup.

---

The RSSI result is displayed on the LED Display panel as a combination of LED states:

OK LED	MODE LED	AUX LED	TX LED	RX LED	RSSI
●	●	●	●	●	$\geq -80$ dBm
●	●	●	●	○	-84 dBm to -81 dBm
●	●	●	○	○	-88 dBm to -85 dBm
●	●	○	○	○	-92 dBm to -89 dBm
●	○	○	○	○	-96 dBm to -93 dBm
●	●	●	●	●	-100 dBm to -97 dBm
●	●	●	●	○	-104 dBm to -101 dBm
●	●	●	○	○	-108 dBm to -105 dBm
●	●	○	○	○	-112 dBm to -109 dBm
●	○	○	○	○	-116 dBm to -113 dBm
●	●	●	●	●	< RSSI threshold
●	●	●	●	●	No response received

## Network Management

The Aprisa SRi contains an embedded web server application (SuperVisor) to enable element management with any major web browser (such as Mozilla Firefox or Microsoft® Internet Explorer).

SuperVisor enables operators to configure and manage the Aprisa SRi base station radio and remote station radios over the radio link.

The key features of SuperVisor are:

- Full element management, configuration and diagnostics
- Manage the entire network from the Base Station (remote management of elements)
- Managed network software distribution and upgrades
- Performance and alarm monitoring of the entire network, including RSSI, alarm states, time-stamped events, etc.
- View and set standard radio configuration parameters including frequencies, transmit power, channel access, serial, Ethernet port settings
- Set and view security parameters
- User management
- Operates over a secure HTTPS session on the access connection to the base station

SuperVisor, when connected to the base station radio allows management of all radios in the network. The Network Table displays a list of all the registered remote stations for the base station and provides management access to each of the remote stations (see 'Network Status > Network Table' on page 246).

## Hardware Alarm Inputs / Outputs

The Aprisa SRi provides two hardware alarm inputs to generate alarm events in the network and two hardware alarm outputs to receive alarm events from the network.

The hardware alarm inputs and outputs are part of the event system. All alarm events can be viewed in SuperVisor event history log (see ‘Events > Event History’ on page 198). These include the alarm events generated by the hardware alarm inputs.

### Alarm Input to SNMP Trap

An alarm event from an Aprisa SRi hardware alarm input can be sent over the air to any SNMP Manager using SNMP traps.

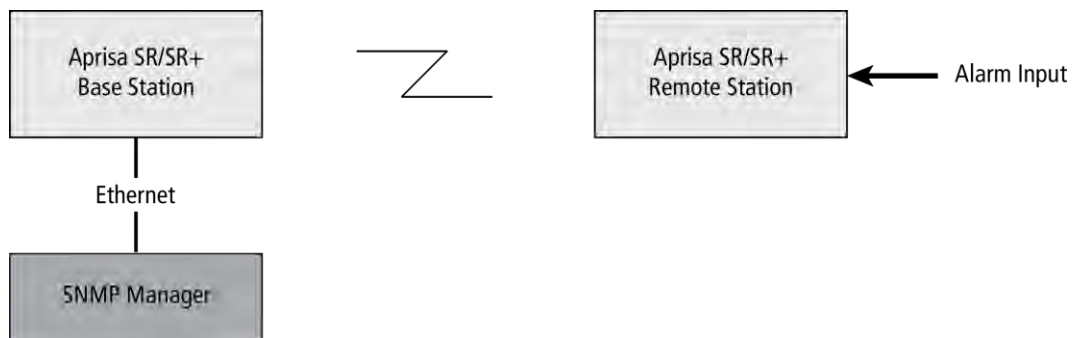

### Alarm Input to Alarm Output

An alarm event from an Aprisa SRi hardware alarm input can be mapped to an hardware alarm output of another SRi using an event action setup (see ‘Events > Event Action Setup’ on page 205).



### Aprisa SR Alarm Input to Aprisa SRi Alarm Output

The Aprisa SRi event action setup feature is compatible with the Aprisa SR.

Since, the Aprisa SR only supports hardware alarm inputs, the Aprisa SRi can be used as an option to provide a hardware alarm output. As shown in the figure below, an Aprisa SRi connected on the same IP network of the Aprisa SR, alarm events from the SR hardware alarm input can be mapped to the hardware alarm output of the SRi using an event action setup.

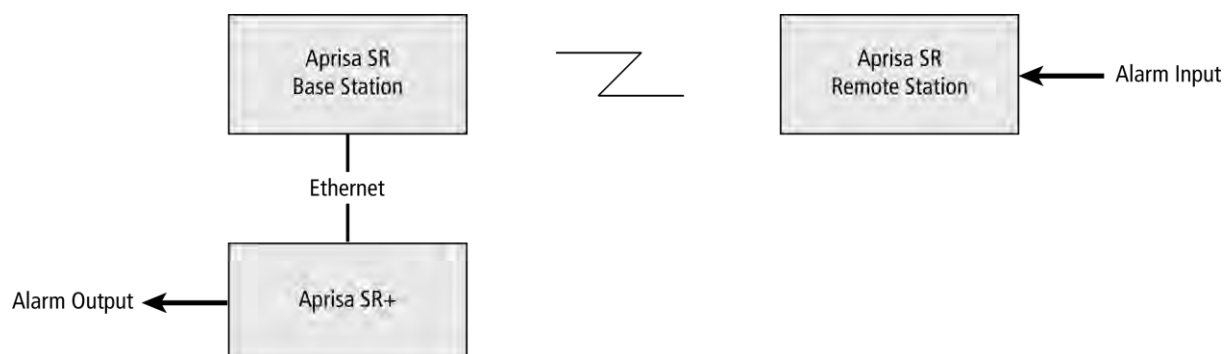

## 4. Implementing the Network

### Network Topologies

The following are examples of typical network topologies:

#### Point-To-Point Network

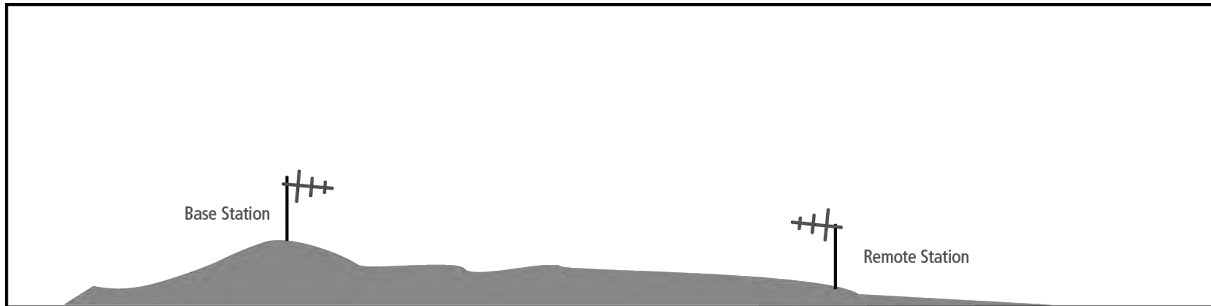

#### Point-to-Multipoint Network

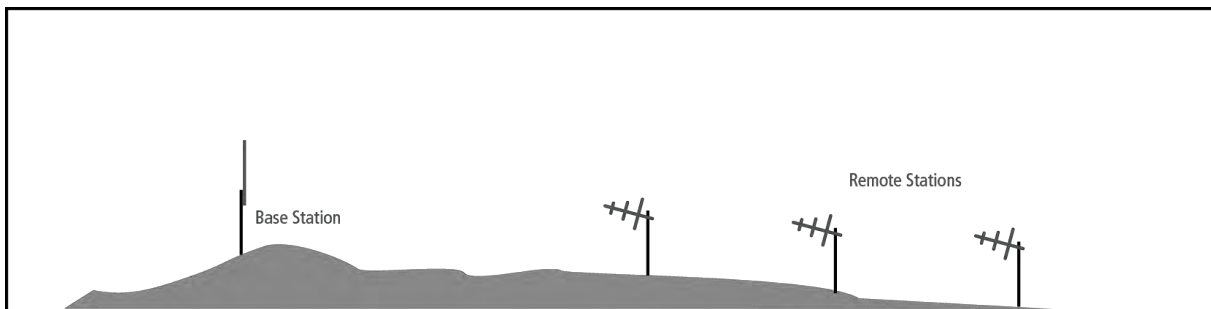

## Initial Network Deployment

### Install the Base Station

To install the base station in your network:

1. Install the base station radio (see 'Installing the Radio' on page 54).
2. Set the radio Network ID to a unique ID in your entire network (see 'Terminal > Device' on page 82).
3. Set the radio operating mode to 'base station' (see 'Terminal > Operating Mode' on page 86).
4. Set the radio IP address (see 'IP > IP Setup > Bridge / Gateway Router Modes' on page 129).
5. Set the radio zones / channels.
6. Set the radio security settings (see 'Security > Setup' on page 162).

### Installing the Remote Stations

To install the remote stations in your network:

1. Install the remote station radio (see 'Installing the Radio' on page 54).
2. Set the radio Network ID to the same ID as the other stations in the network (see 'Terminal > Device' on page 82).
3. Set the radio operating mode to 'remote station' (see 'Terminal > Operating Mode' on page 86).
4. Set the radio IP address (see 'IP > IP Setup > Bridge / Gateway Router Modes' on page 129).
5. Set the radio zones / channels to be compatible with the base station.
6. Set the radio security settings to the same as the base station (see 'Security > Setup' on page 162).

The base station will automatically allocate a node address to the new remote station.

## Network Changes

### Adding a Remote Station

**To add a remote station to your network:**

1. Install the remote station radio (see 'Installing the Radio' on page 54).
2. Set the radio Network ID to the same ID as the other stations in the network (see 'Terminal > Device' on page 82).
3. Set the radio IP address (see 'IP > IP Setup > Bridge / Gateway Router Modes' on page 129).).
4. Set the radio zones / channels to be compatible with the base station.
5. Set the radio operating mode to 'remote station' (see 'Terminal > Operating Mode' on page 86).

The base station will automatically allocate a node address to the new remote station.

**To remove a remote station from your network:**

1. Turn the power off on the remote station radio you wish to remove. This is the only action that is required.

---

**Note:** The remote station will continue to show in the Network Table list.

---

## 5. Preparation

### Bench Setup

Before installing the links in the field, it is recommended that you bench-test the links. A suggested setup for basic bench testing is shown below:

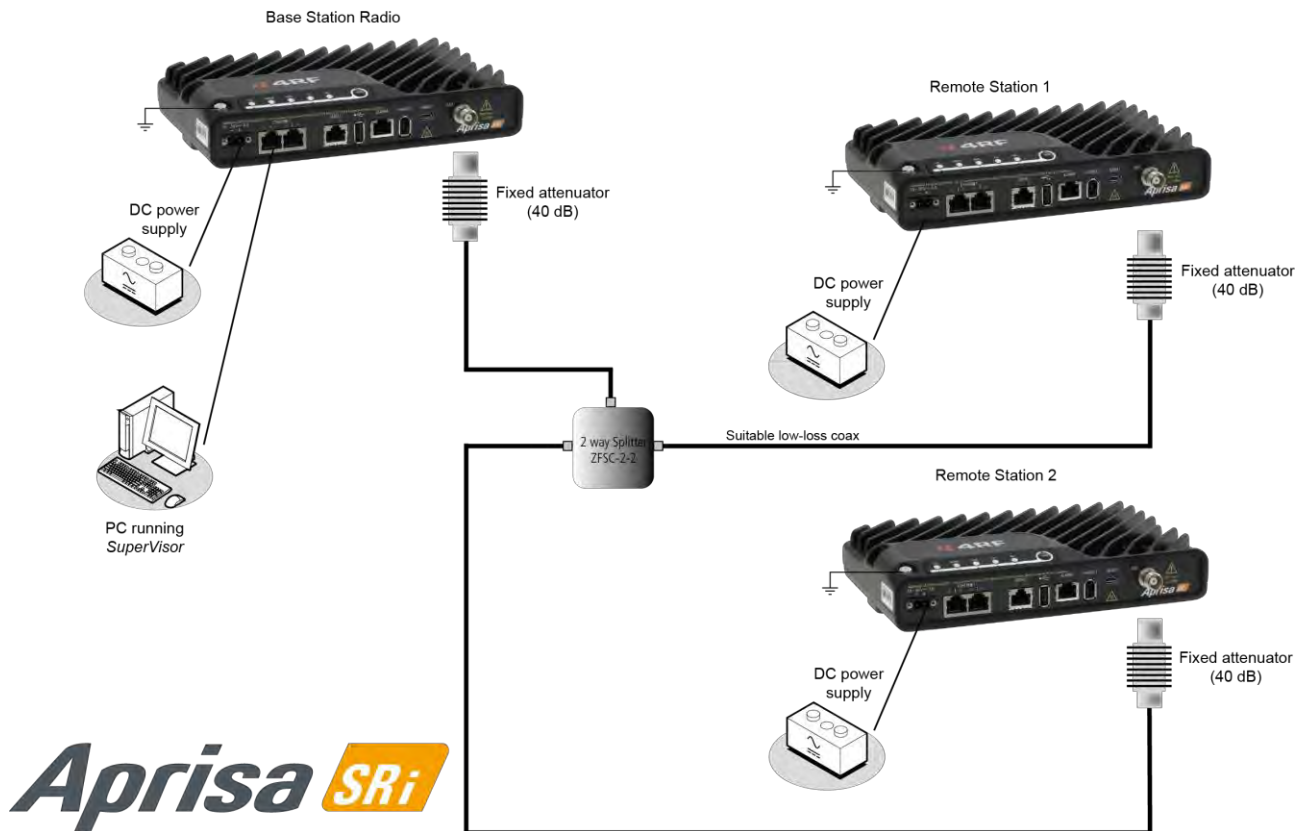

When setting up the equipment for bench testing, note the following:

#### Earthing

Each radio should be earthed at all times. The radio earth point should be connected to a protection earth.

#### Attenuators

In a bench setup, there should be 60 - 80 dB at up to 1 GHz of 50 ohm coaxial attenuation, capable of handling the transmit power of +26 dBm (0.4 W) between the radios' antenna connectors.

#### Splitter

If more than two radios are required in your bench setup, a multi-way splitter is required. The diagram shows a two way splitter. This splitter should be 50 ohm coaxial up to 1 GHz and capable of handling the transmit power of +26 dBm (0.4 W).

#### Cables

Use double-screened coaxial cable that is suitable for use up to 1 GHz at  $\approx 1$  metre.

---

**CAUTION:** Do not apply signals greater than +10 dBm to the antenna connection as they can damage the receiver.

---

## Compliance Considerations

The Aprisa SRi is a professional radio product and as such must be installed by a suitably trained and qualified installer who is aware of the local regulatory requirements existing at the time of installation and is capable of ensuring that the regulations are adhered to.

The maximum Equivalent Isotropic Radiated Power (EIRP) permitted from the Aprisa SRi is regulated and must not exceed the limits provided in the following table. To meet this regulatory requirement; knowledge of the antenna gain and feeder cable loss must be known before setting the transmitter output power.

Regulatory Requirement	Frequency Range	Maximum EIRP <sup>1</sup>	SRi Equivalent Maximum Average Power ( $R_{dBm}$ )
USA, FCC Part 15.247	902 MHz to 928 MHz	+36 dBm PEP	+32 dBm
Canada, IC RSS-247	902 MHz to 928 MHz	+36 dBm PEP	+32 dBm
Australia, ACMA AS/NZS 4268	915 MHz to 928 MHz	+30 dBm	+30 dBm
New Zealand, General User Radio Licence for Short Range Devices	915 MHz to 928 MHz	+30 dBm	+30 dBm
New Zealand, General User Radio Licence for Short Range Devices	920 MHz to 928 MHz	+36 dBm	+36 dBm

The Aprisa SRi has a maximum mean output power of +26 dBm into a 50 ohm antenna which equates to a maximum peak power of +30 dBm PEP. To determine the maximum power to be set on the Aprisa SRi, the following installation parameters must be known:

1. Aprisa SRi equivalent average power for maximum permitted EIRP (specified in dBm)  $R_{dBm}$
2. Antenna isotropic gain (specified in dBi)  $G_{dBi}$
3. Feeder coax loss between Aprisa SRi and antenna (specified in dB/m)  $L_{dB/m}$
4. Length of feeder coax between Aprisa SRi and antenna (specified in metres)  $d_m$

From these the above information, the power setting of the Aprisa SRi ( $P_{dBm}$ ) can be calculated to ensure operation within the regulatory requirements using the formula:

$$P_{dBm} = R_{dBm} + (d_m \times L_{dB/m}) - G_{dBi}$$

Antenna gain information can be obtained from the Antenna manufacturer and is either expressed in terms of dBi, referenced to an isotropic radiator, or dBd, referenced to a dipole.

If the gain is expressed in dBd, it can be converted to dBi by adding 2.15 dB to the gain value.

<sup>1</sup> These are correct at the time of printing. The installer must ensure that the installation complies with the regulatory requirements at the time of installation.



This radio transmitter Aprisa SRi IC: 6772A-SI902M160 has been approved by Industry Canada to operate with the antenna types listed below with the maximum permissible gain indicated. Antenna types not included in this list, having a gain greater than the maximum gain indicated for that type, are strictly prohibited for use with this device.

The following is an example of transmitter power calculations:

Antenna Type and Gain	Feeder Coax Length and Loss	Regulatory Limit	Maximum SRi Power Setting
Yagi, 11 dBi	10 m of ½" Helix @ 0.11 dB/m gives 1.1 dB loss	+36 dBm PEP	22 dBm
Panel, 12 dBi	33 m of RG214 @ 0.22 dB/m gives 7.3 dB loss	+30 dBm	25 dBm
Dipole, 3.5 dBi	3 m of RG214 @ 0.22 dB/m gives 0.66 dB loss	+30 dBm	26 dBm
Grid, 18 dBi	15 m of ½" Helix @ 0.11 dB/m gives 1.65 dB loss	+30 dBm	13 dBm

## Path Planning

The following factors should be considered to achieve optimum path planning:

- Antenna Selection and Siting
- Coaxial Cable Selection
- Linking System Plan

## Antenna Selection and Siting

Selecting and siting antennas are important considerations in your system design. The antenna choice for the site is determined primarily by the frequency of operation and the gain required to establish reliable links.

### Base Station

The predominant antenna for a base station is an omni-directional collinear gain antenna.

#### Omni Directional Collinear Antennas

	<b>Factor</b>	<b>Explanation</b>
	Frequency	Often used in 380-530 MHz bands
	Gain	Varies with size (5 dBi to 8 dBi typical)
	Wind loading	Minimal
	Tower aperture required	Minimal
	Size	Range from 2 m to 3 m length
	Polarization	Vertical

## Remote station

There are two main types of directional antenna that are commonly used for remote stations, Yagi and corner reflector antennas.

### Yagi Antennas

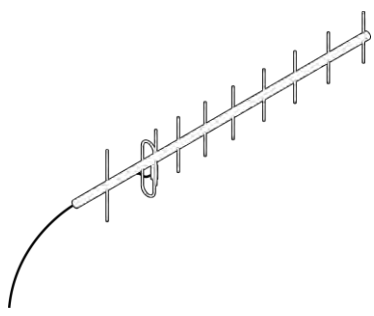
	<b>Factor</b>	<b>Explanation</b>
	Frequency	Often used in 350-600 MHz bands
	Gain	Varies with size (typically 11 dBi to 16 dBi)
	Stackable gain increase	2 Yagi antennas (+ 2.8 dB) 4 Yagi antennas (+ 5.6 dB)
	Size	Range from 0.6 m to 3 m in length
	Front to back ratio	Low (typically 18 to 20 dB)

It is possible to increase the gain of a Yagi antenna installation by placing two or more of them in a stack. The relative position of the antennas is critical.

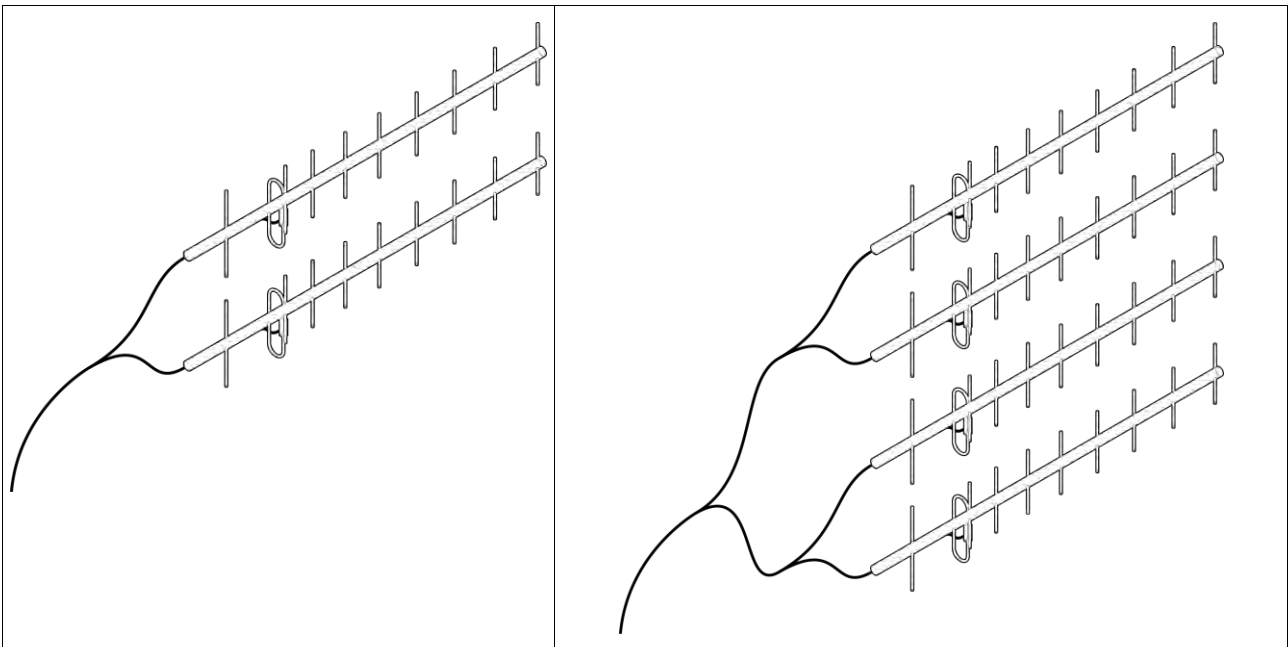

Example of stacked antennas

## Corner Reflector Antennas

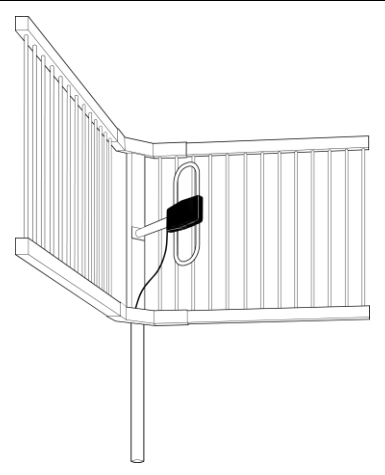
	<b>Factor</b>	<b>Explanation</b>
	Frequency	Often used in 330-960 MHz bands
	Gain	Typically 12 dBi
	Size	Range from 0.36 m to 0.75 m in length
	Front to back ratio	High (typically 30 dB)
	Beamwidth	Broad (up to 60°)

## Antenna Siting

When siting antennas, consider the following points:

A site with a clear line of sight to the remote radio is recommended. Pay particular attention to trees, buildings, and other obstructions close to the antenna site.

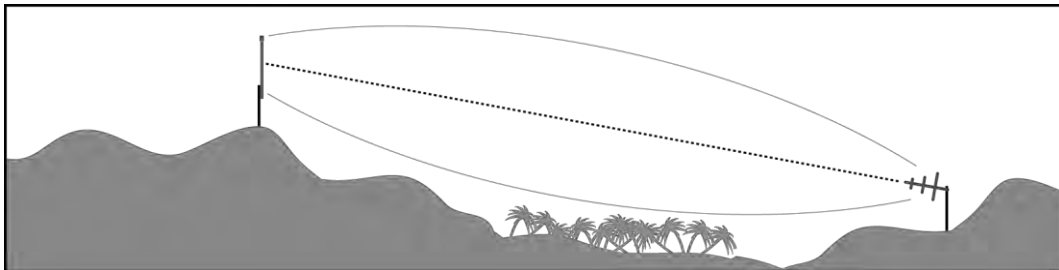

Example of a clear line-of-sight path

Any large flat areas that reflect RF energy along the link path, for instance, water, could cause multipath fading. If the link path crosses a feature that is likely to cause RF reflections, shield the antenna from the reflected signals by positioning it on the far side of the roof of the equipment shelter or other structure.

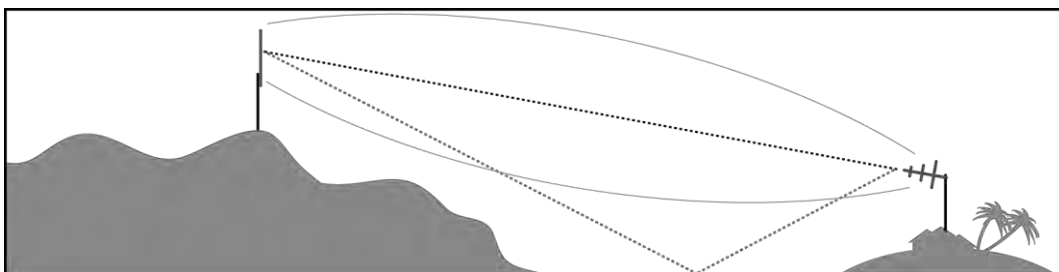

Example of a mid-path reflection path

The antenna site should be as far as possible from other potential sources of RF interference such as electrical equipment, power lines and roads. The antenna site should be as close as possible to the equipment shelter.

Wide angle and zoom photographs taken at the proposed antenna location (looking down the proposed path), can be useful when considering the best mounting positions.

## Coaxial Feeder Cables

To ensure maximum performance, it is recommended that you use good quality low-loss coaxial cable for all feeder runs. When selecting a coaxial cable consider the following:

Factor	Effect
Attenuation	Short cables and larger diameter cables have less attenuation
Cost	Smaller diameter cables are cheaper
Ease of installation	Easier with smaller diameter cables or short cables

For installations requiring long feeder cable runs, use the RFI AVA5 50, RFI LDF4 50A or RFI CNT-400 feeder cable or equivalent:

Part Number	Part Description	Specification
RFI AVA5 50	Feeder Cable, 7/8", HELIAX, Low loss	7/8" foam dielectric. Standard Jacket Outer conductor corrugated copper, inner conductor copper-clad aluminum Bending radius of 250 mm min Attenuation of 2.65 dB / 100m @ 520 MHz
RFI LDF4 50A	Feeder cable, 1/2", HELIAX, Loss Loss	1/2" foam dielectric. Standard Jacket Outer conductor corrugated copper, inner conductor copper-clad aluminum Bending radius of 125 mm min Attenuation of 5.1 dB / 100m @ 520 MHz
RFI CNT 400	Feeder, CNT-400, 10.8mm, Double Shielded Solid Polyethylene	Low loss 0.4' (10.8 mm) feeder cable UV protected black Polyethylene, bonded AL tape outer conductor Bending radius of 30 mm min Attenuation of 8.8 dB / 100m @ 450 MHz

For installations requiring short feeder cable runs, use the RFI 8223 feeder cable or equivalent:

Part Number	Part Description	Specification
RFI 8223	Feeder, RG 223 5.4mm d, Double Shielded Solid Polyethylene	Bending radius of 20 mm min Attenuation of 30.5 dB / 100m @ 450 MHz

When running cables:

Run coaxial feeder cable from the installation to the antenna, ensuring you leave enough extra cable at each end to allow drip loops to be formed.

Terminate and ground the feeder cables in accordance with the manufacturers' instructions. Bond the outer conductor of the coaxial feeder cables to the base of the tower mast.

## Linking System Plan

All of the above factors combine in any proposed installation to create a Linking System Plan. The Linking System Plan predicts how well the radios will perform after it is installed.

Use the outputs of the Linking System Plan during commissioning to confirm the radios have been installed correctly and that it will provide reliable service.

# Site Requirements

## Power Supply

Ensure a suitable power supply is available for powering the radio.

The nominal input voltage for a radio is +13.8 VDC (negative earth) with an input voltage range of +10 to +30 VDC. The maximum power input is 25 W.



**WARNING:**

Before connecting power to the radio, ensure that the radio is grounded via the negative terminal of the DC power connection.

---

## Equipment Cooling

If the Aprisa SRi is operated in an environment where the ambient temperature exceeds 50°C, the Aprisa SRi convection air flow over the heat sinks must be considered.

The environmental operating conditions are as follows:

Operating temperature	-40 to +70° C
Storage temperature	-40 to +80° C
Humidity	Maximum 95% non-condensing



**WARNING:**

If the Aprisa SRi is operated in an environment where the ambient temperature exceeds 50°C, the Aprisa SRi must be installed within a restricted access location to prevent human contact with the enclosure heat sink.

---



**WARNING:**

The Aprisa SRi can be operated in an environment where the ambient temperature exceeds 50°C. The heat sink will be a hot surface - do not touch.

---

## Earthing and Lightning Protection



**WARNING:**

Lightning can easily damage electronic equipment.

To avoid this risk, install primary lightning protection devices on any interfaces that are reticulated in the local cable network.

You should also install a coaxial surge suppressor on the radio antenna port.

### Feeder Earthing

Earth the antenna tower, feeders and lightning protection devices in accordance with the appropriate local and national standards. The diagram below shows the minimum requirements.

Use grounding kits as specified or supplied by the coaxial cable manufacturer to properly ground or bond the cable outer.

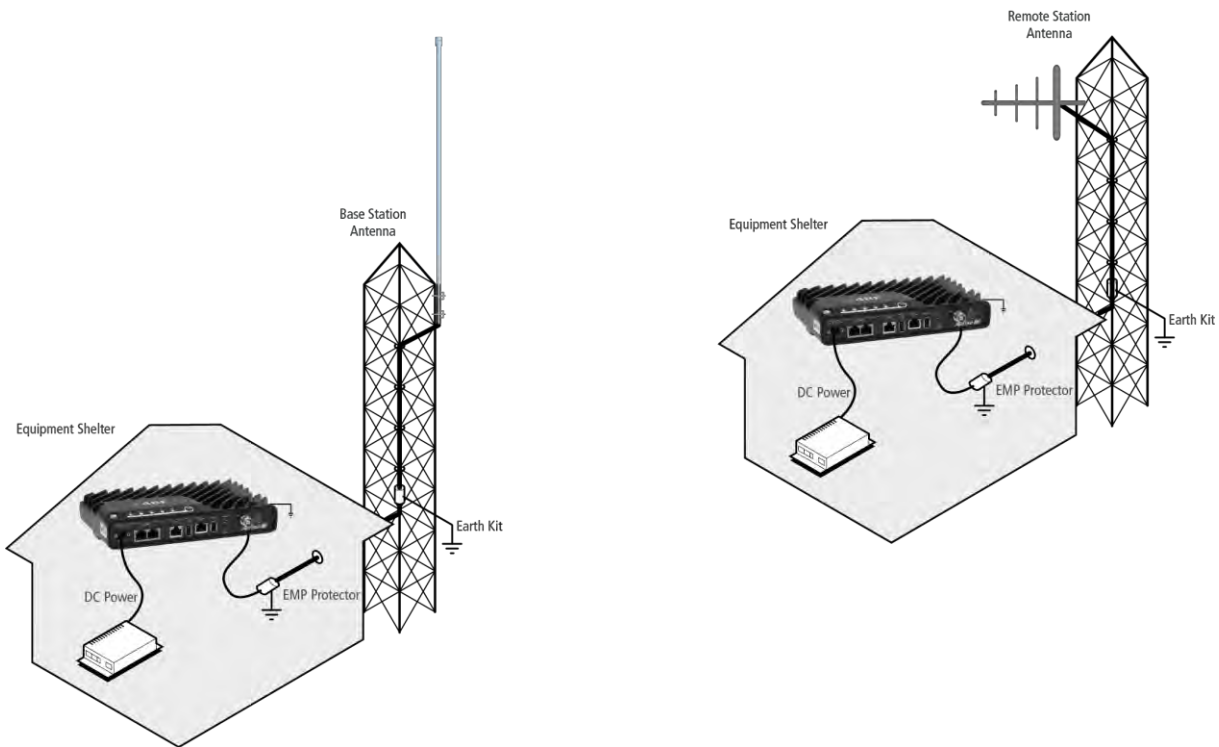

### Radio Earthing

The Aprisa SRi has an earth connection point on the top left of the enclosure. M4 8mm pan pozi machine screws and M4 lock washers are supplied fitted to the radio. These screws can be used to earth the enclosure to a protection earth.



## 6. Installing the Radio



### CAUTION:

You must comply with the safety precautions in this manual or on the product itself.

4RF does not assume any liability for failure to comply with these precautions.

## Mounting

The Aprisa SRi has four threaded holes (M4) in the enclosure base and two holes (5.2 mm) through the enclosure for mounting.

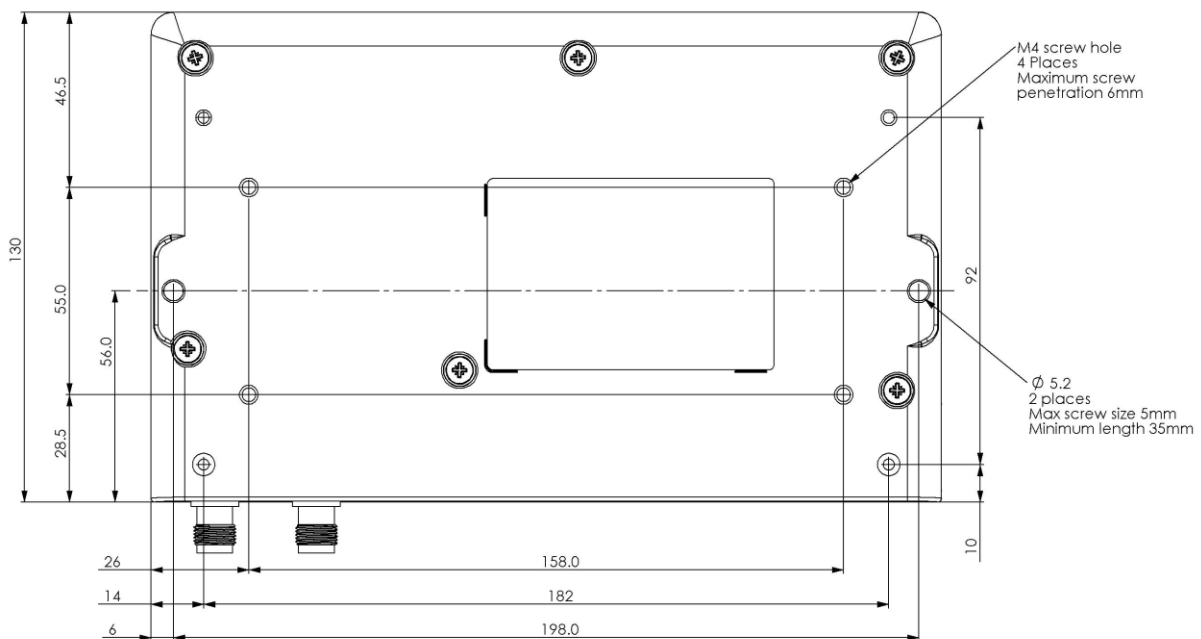

Mounting options include:

- DIN rail mounting with the Aprisa SRi DIN Rail Mounting Bracket
- Rack shelf mounting
- Wall mounting
- Outdoor enclosure mounting



### WARNING:

If the Aprisa SRi is operated in an environment where the ambient temperature exceeds 50°C, the Aprisa SRi must be installed within a restricted access location to prevent human contact with the enclosure heatsink.

## Required Tools

No special tools are needed to install the radio.



## DIN Rail Mounting

The Aprisa SRi has an optional accessory part to enable the mounting on a standard DIN rail:

Part Number	Part Description
APSB-MBRK-DIN	4RF SRi Acc, Mounting, Bracket, DIN Rail

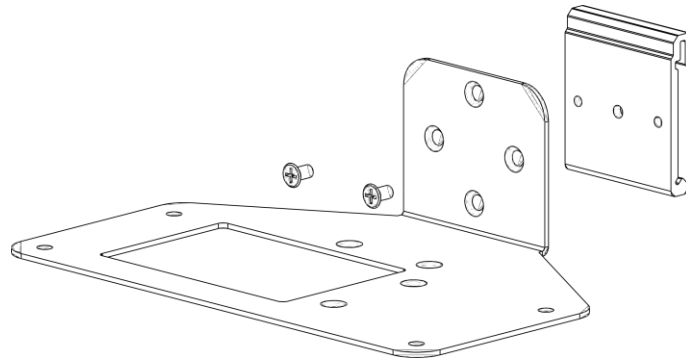

The Aprisa SRi is mounted into the DIN rail mounting bracket using the four M4 threaded holes in the Aprisa SRi enclosure base. Four 8 mm M4 pan pozi machine screws are supplied with the bracket.

The Aprisa SRi DIN rail mounting bracket can be mounted in four positions on a horizontal DIN rail:

- Vertical Mount (vertical enclosure perpendicular to the mount)
- Horizontal Mount (horizontal enclosure perpendicular to the mount)
- Flat Vertical Mount (vertical enclosure parallel to the mount)
- Flat Horizontal Mount (horizontal enclosure parallel to the mount)

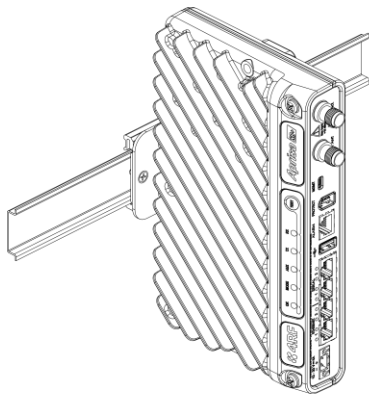

Vertical Mount

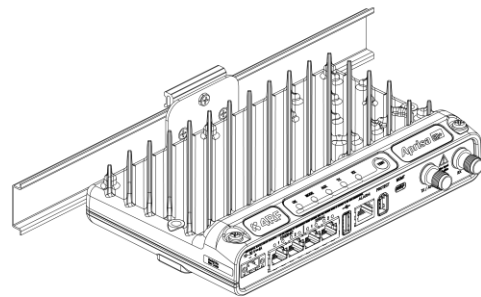

Horizontal Mount

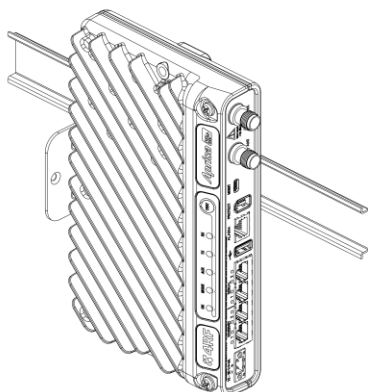

Flat Vertical Mount

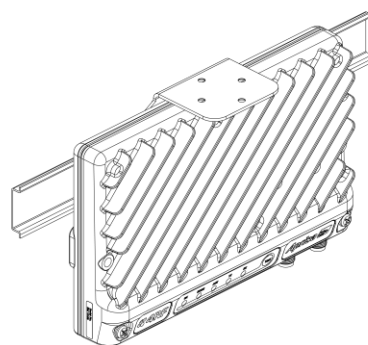

Flat Horizontal Mount

## Rack Shelf Mounting

The Aprisa SRi can be mounted on a rack mount shelf using the four M4 threaded holes in the Aprisa SRi enclosure base. The following picture shows Aprisa SRi mounted on a 1 RU rack mounted shelf.

Part Number	Part Description
APSB-MR19-X1U	4RF SRi Acc, Mounting, 19" Rack Mount Shelf, 1U

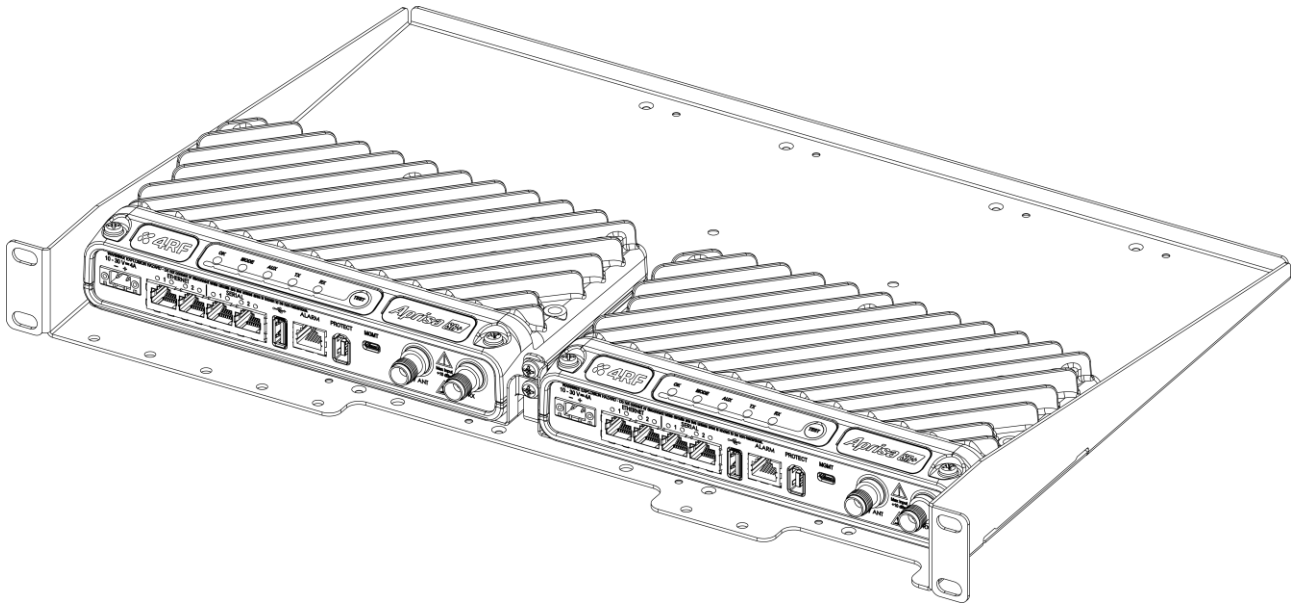

---

**WARNING:**

If the Aprisa SRi is operated in an environment where the ambient temperature exceeds 50°C, the Aprisa SRi convection air flow over the heat sinks must be considered.

---

## Wall Mounting

The Aprisa SRi can be mounted on a wall using the two holes through the enclosure (5.2 mm diameter). Typically, M5 screws longer than 35 mm would be used.

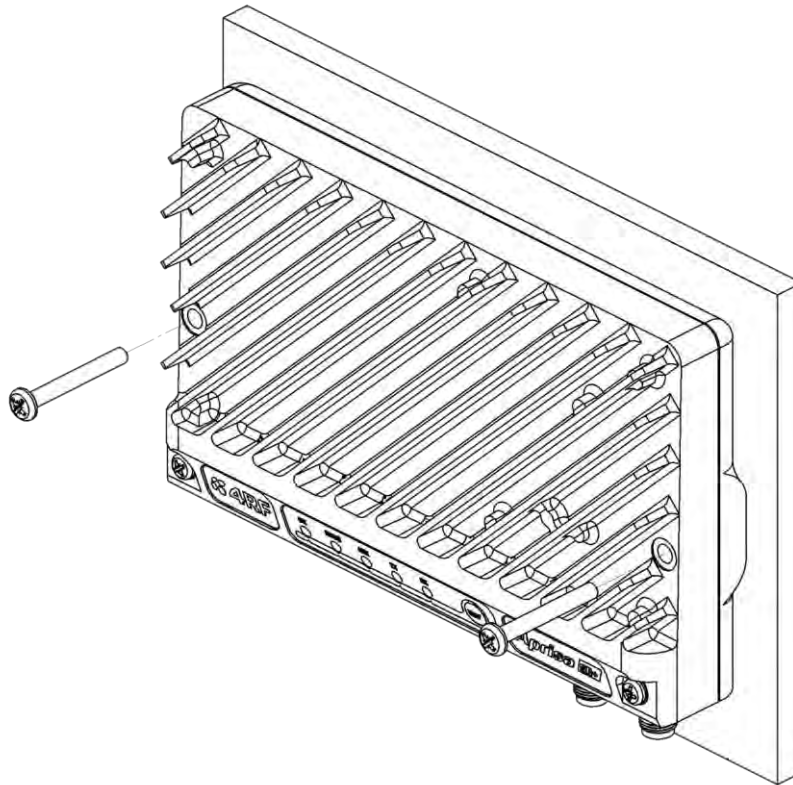

## Installing the Antenna and Feeder Cable

Carefully mount the antenna following the antenna manufacturers' instructions. Run feeder cable from the antenna to the radio location.

Lightning protection must be incorporated into the antenna system (see 'Earthing and Lightning Protection' on page 53).



---

**WARNING:**

When the link is operating, there is RF energy radiated from the antenna. Do not stand in front of the antenna while the radio is operating (see the 'RF Exposure Warning' on page 3).

---

Fit the appropriate male or female connector (usually N-type) to the antenna feeder at the antenna end. Carefully follow the connector manufacturers' instructions.

Securely attach the feeder cable to the mast and cable trays using cable ties or cable hangers. Follow the cable manufacturer's recommendations about the use of feeder clips, and their recommended spacing.

Connect the antenna and feeder cable. Weatherproof the connection with a boot, tape or other approved method.

The Aprisa SRi antenna connection is a TNC female connector so the feeder / jumper must be fitted with a TNC male connector.

If a jumper is used between the feeder and the radio, connect a coaxial surge suppressor or similar lightning protector between the feeder and jumper cables (or at the point where the cable enters the equipment shelter). Connect the feeder cable to the antenna port on the radio.

Earth the case of the lightning protector to the site Lightning Protection Earth.

The Aprisa SRi has an earth connection point on the top left of the enclosure. M4 8mm pan pozi machine screws and M4 lock washers are supplied fitted to the radio. These screws can be used to earth the enclosure to a protection earth.



## Connecting the Power Supply

The nominal input voltage for a radio is +13.8 VDC (negative earth) with an input voltage range of +10 to +30 VDC. The maximum power input is 25 W.

The power connector required is a Molex 2 pin female screw fitting part. This connector is supplied fitted to the radio.



The negative supply of the Aprisa SRi power connection is internally connected to the Aprisa SRi enclosure. Power must be supplied from a Negative Earthed power supply.

Wire your power source to power connector and plug the connector into the radio. The connector screws can be fastened to secure the connector.

Spare Molex 2 pin female power connectors can be ordered from 4RF:

Part Number	Part Description
APST-CML2-FEM-01	4RF SRi Spare, Connector, Molex 2 pin, Female, 1 item

Turn your power source on:

- All the radio LEDs will flash orange for one second and then the OK, MODE and AUX LEDs will light green, the TX and RX LEDs will flash red.
- The Aprisa SRi radio is ready to operate
- The TX and RX LEDs will be green (steady or flashing) when the radio is registered with the network.

If the LEDs fail to light, carefully check the supply polarity. If the power supply connections have been accidentally reversed, internal fuses will have blown to protect the unit.

Spare fuses are contained within the radio, see 'Spare Fuses' on page 60 for instructions on how to locate and replace the fuses.

## External Power Supplies

The following external power supplies are available from 4RF as accessories:

Part Number	Part Description
APSB-P230-030-24-TS	4RF SRi Acc, PSU, 230 VAC, 30W, 24 VDC, -10 to +60C
APSB-P230-048-24-TE	4RF SRi Acc, PSU, 230 VAC, 48W, 24 VDC, -20 to +75C
APSB-P230-060-24-TS	4RF SRi Acc, PSU, 230 VAC, 60W, 24 VDC, -10 to +60C
APSB-P48D-050-24-TA	4RF SRi Acc, PSU, 48 VDC, 50W, 24 VDC, 0 to +50C

## Spare Fuses

The Aprisa SRi PBA contains two fuses in the power input with designators F1 and F2. Both the positive and negative power connections are fused. The fuse type is a Littelfuse 0454007 with a rating of 7 A, 75 V, very fast acting.

### To replace the fuses:

1. Remove the input power and antenna cable.
2. Unscrew the enclosure securing screws (posi 2).

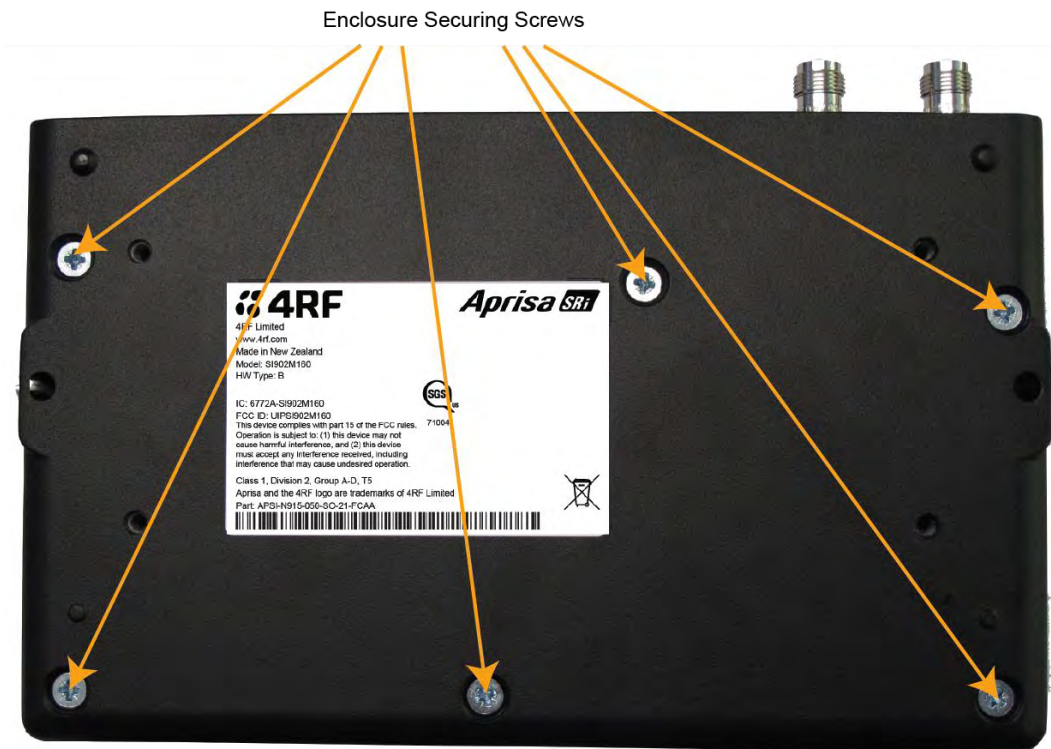

2. Separate the enclosure halves.

---

**CAUTION:** Antistatic precautions must be taken as the internal components are static sensitive.

---

3. Access the enclosure spare fuses under the plastic cap.





- Replace the two fuses.

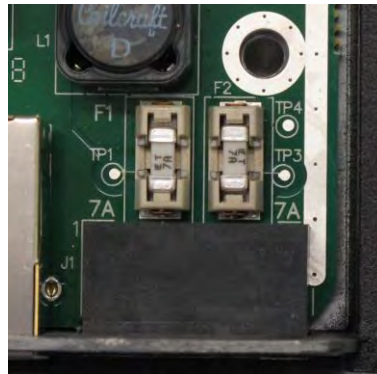

- Close the enclosure and tighten the screws.

---

**Note:** Is it critical that the screws are re-tightened to 1.2 Nm. The transmitter adjacent channel performance can be degraded if the screws are not tightened correctly.

---

## Additional Spare Fuses

Additional spare fuses can be ordered from 4RF:

Part Number	Part Description
APST-FNAN-454-07-02	4RF SRi Spare, Fuse, Nano SMF, 454 Series, 7A, 2 items





## 7. Managing the Radio

### SuperVisor

The Aprisa SRi contains an embedded web server application (SuperVisor) to enable element management with any major web browser (such as Mozilla Firefox or Microsoft® Internet Explorer).

SuperVisor enables operators to configure and manage the Aprisa SRi base station radio and remote station radios over the radio link.

The key features of SuperVisor are:

- Full element management, configuration and diagnostics
- Manage the entire network from the Base Station (remote management of elements)
- Managed network software distribution and upgrades
- Performance and alarm monitoring of the entire network, including alarm states, time-stamped events, etc.
- View and set standard radio configuration parameters including frequencies, transmit power, channel access, serial, Ethernet port settings
- Set and view security parameters
- User management
- Operates over a secure HTTPS session on the access connection to the base station

## PC Requirements for SuperVisor

SuperVisor requires the following minimum PC requirements:

Browser	Operating System	Processor	RAM
Internet Explorer 7 (oldest browser supported) IE7 can operate with less but will be very slow.	MS-Windows XP Service Pack 2	1 GHz processor	1 GB Ram
Internet Explorer 9 Does not support config file upload from PC	MS-Windows Vista Service Pack 2	1 GHz processor	2 GB Ram
Internet Explorer 10 (recommended minimum browser)	MS-Windows 7 Service Pack 1	1 GHz processor	2 GB Ram
Internet Explorer 11	MS-Windows 8.1	1 GHz processor	2 GB Ram
Mozilla Firefox (MS-Windows)	MS-Windows XP Service Pack 2	1 GHz processor, Pentium 4 and above	1 GB Ram
Mozilla Firefox (Linux)	Gnome desktop 2.18 and above	1 GHz processor, Pentium 4 and above	1 GB Ram
Mozilla Firefox (Apple Mac) (4RF does not support retina displays)	Mac OS X 10.6	1 GHz processor, Pentium 4 and above	1 GB Ram

---

**Note:** 4RF does not support Google Chrome, Opera browser or Apple Safari but when they have been used they have worked correctly.

---

## Connecting to SuperVisor

The predominant management connection to the Aprisa SRi radio is with an Ethernet interface using standard IP networking. There should be only one Ethernet connection from the base station to the management network.

The Aprisa SRi has a factory default IP address of 169.254.50.10 with a subnet mask of 255.255.0.0. This is an IPv4 Link Local (RFC3927) address which simplifies the connection to a PC.

Each radio in the network must be set up with a unique IP address on the same subnet.

### To change the Aprisa SRi IP address:

1. Set up your PC for a compatible IP address e.g. 169.254.50.1 with a subnet mask of 255.255.0.0.
2. Connect your PC network port to one of the Aprisa SRi Ethernet ports.
3. Open a browser and enter <https://169.254.50.10>.
4. Login to the radio with the default Username 'admin' and Password 'admin'.
5. Change the IP address to conform to the network plan in use.

## Management PC Connection

The active management PC must only have one connection to the network as shown by path ①. There should not be any alternate path that the active management PC can use via an alternate router or alternate LAN that would allow the management traffic to be looped as shown by path ②.

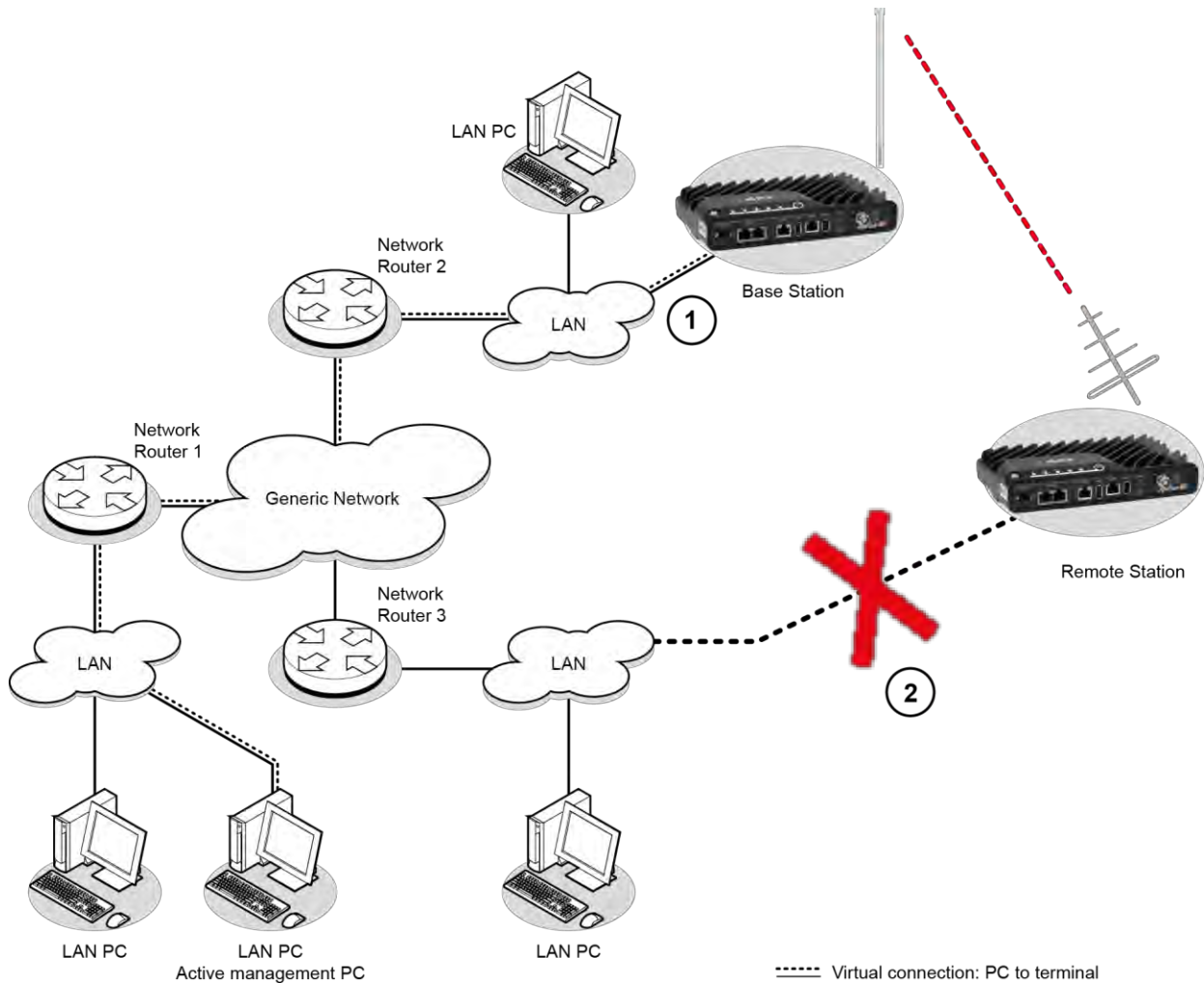

When logging into a network, it is important to understand the relationship between the Local Radio and the Remote Radios.

The Local Radio is the radio that your IP network is physically connected to.

If the Local Radio is a base station, SuperVisor manages the base station and all the remote stations in the network.

If the Local Radio is a remote station, SuperVisor only manages the remote station radio logged into.

If the user is at the remote station and connects SuperVisor directly to the remote radio via their computer, all relevant features are still available. This includes the ability to monitor the 'Last received packet RSSI. If ICMP is enabled on the base station, the user will also be able to ping the base station to confirm the connectivity.

## PC Settings for SuperVisor

### To change the PC IP address:

If your PC has previously been used for other applications, you may need to change the IP address and the subnet mask settings. You will require Administrator rights on your PC to change these.

Windows XP example:

1. Open the 'Control Panel'.
2. Open 'Network Connections' and right click on the 'Local Area Connection' and select 'Properties'.
3. Click on the 'General' tab.
4. Click on 'Internet Protocol (TCP/IP)' and click on properties.
5. Enter the IP address and the subnet mask (example as shown).
6. Click 'OK' then close the Control Panel.

If the radio is on a different subnet from the network the PC is on, set the PC default gateway address to the network gateway address which is the address of the router used to connect the subnets (for details, consult your network administrator).

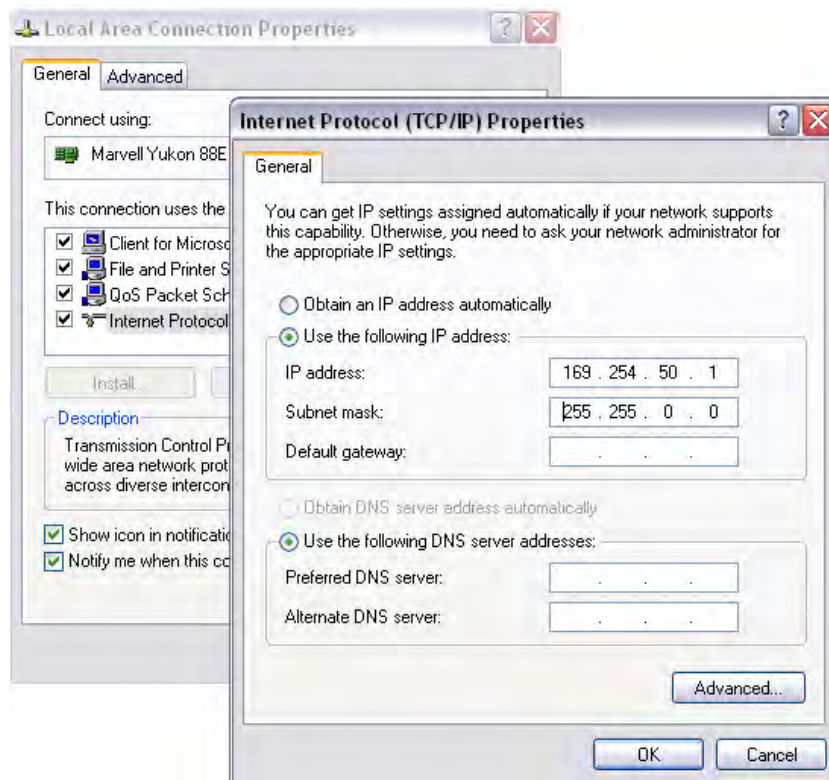

**To change the PC connection type:**

If your PC has previously been used with Dial-up connections, you may need to change your PC Internet Connection setting to 'Never dial a connection'.

Windows Internet Explorer 8 example:

1. Open Internet Explorer.
2. Open the menu item Tools > Internet Options and click on the 'Connections' tab.
3. Click the 'Never dial a connection' option.

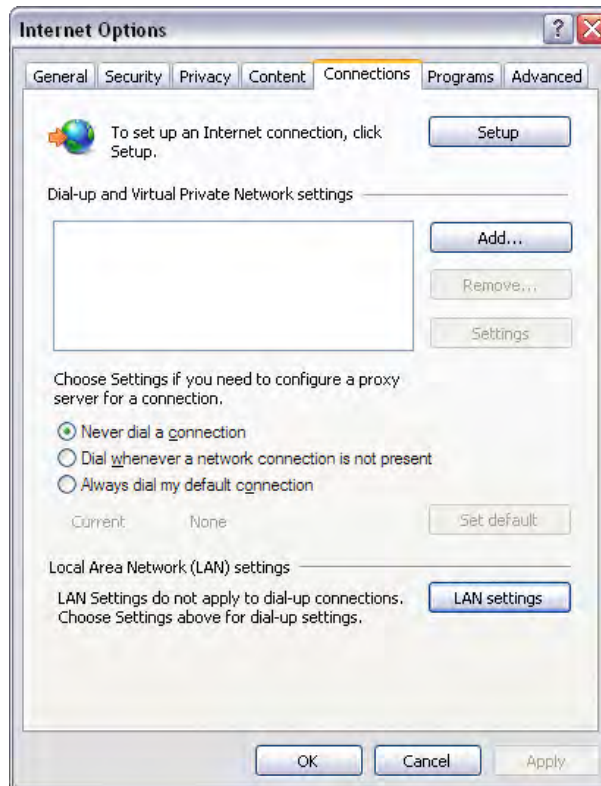

**To change the PC pop-up status:**

Some functions within SuperVisor require Pop-ups enabled e.g. saving a MIB

Windows Internet Explorer 8 example:

1. Open Internet Explorer.
2. Open the menu item Tools > Internet Options and click on the 'Privacy' tab.
3. Click on 'Pop-up Blocker Settings'.
4. Set the 'Address of Web site to allow' to the radio address or set the 'Blocking Level' to 'Low: Allow Pop-ups from secure sites' and close the window.

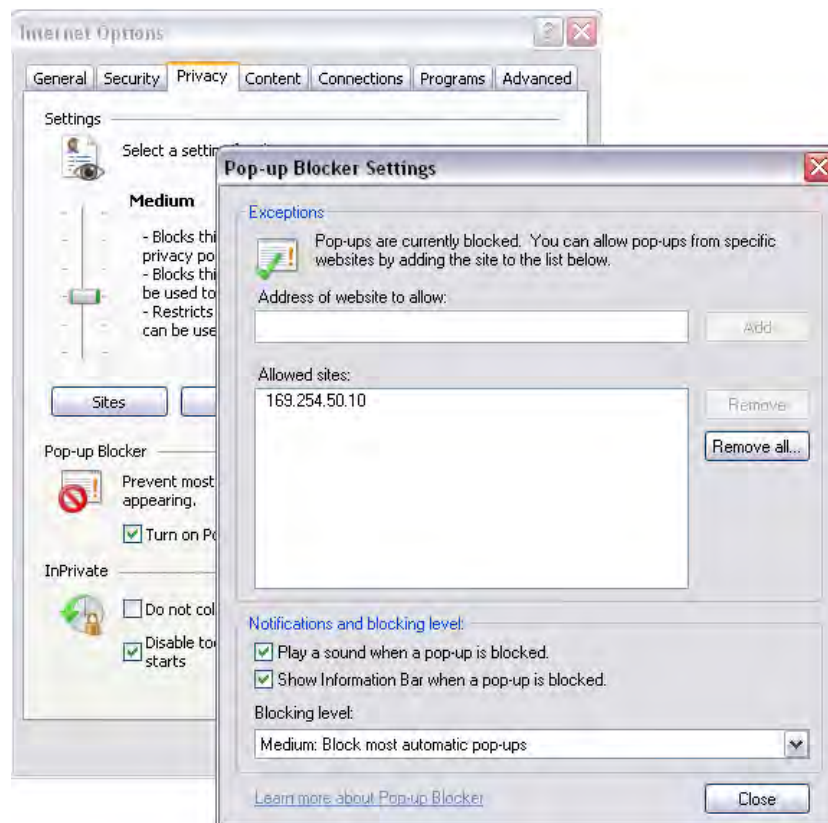

**To enable JavaScript in the web browser:**

Some functions within SuperVisor require JavaScript in the web browser to be enabled.

Windows Internet Explorer 8 example:

1. Open Internet Explorer.
2. Open the menu item Tools > Internet Options and click on the 'Security' tab.
3. Click on 'Local Intranet'.
4. Click on 'Custom Level'.
5. Scroll down until you see section labeled 'Scripting'.
6. Under 'Active Scripting', select 'Enable'.

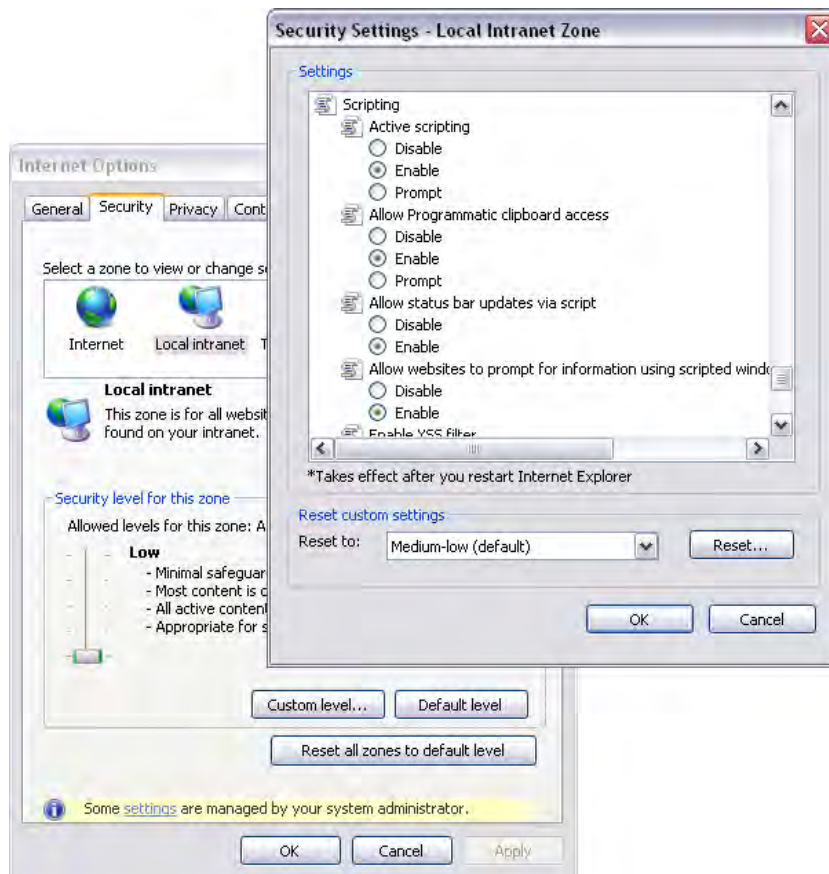



## Login to SuperVisor

The maximum number of concurrent users that can be logged into a radio is 6.

If SuperVisor is inactive for a period defined by the Inactivity Timeout option (see 'Maintenance > General' on page 185), the radio will automatically logout the user.

### To login to SuperVisor:

1. Open your web browser and enter the IP address of the radio.

If you haven't assigned an IP address to the radio, use the factory default IP address of 169.254.50.10 with a subnet mask of 255.255.0.0.

If you don't know the IP address of the radio, you can determine it using the Command Line Interface (see 'Command Line Interface' on page 253).

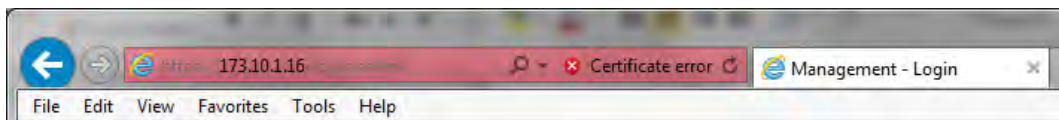



---

**Note:** The Aprisa SRi has a randomly generated unique self-signed ECC256 security certificate which may cause the browser to prompt a certificate warning. It is safe to ignore the warning and continue. The valid certificate is 'Issued By: 4RF-APRISA' which can be viewed in the browser.

---

2. Login with the Username and Password assigned to you.

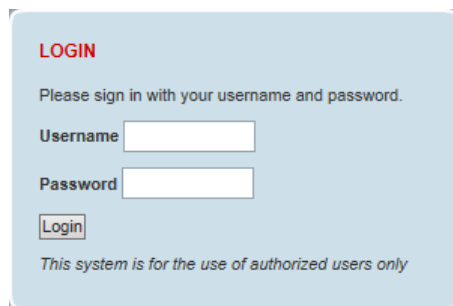
If unique usernames and passwords have not yet been configured, use the default username 'admin' and password 'admin'.





---

**Important:** After you login for the very first time, it is recommended that you change the default admin password for security reasons (see 'Changing Passwords' on page 171).

---

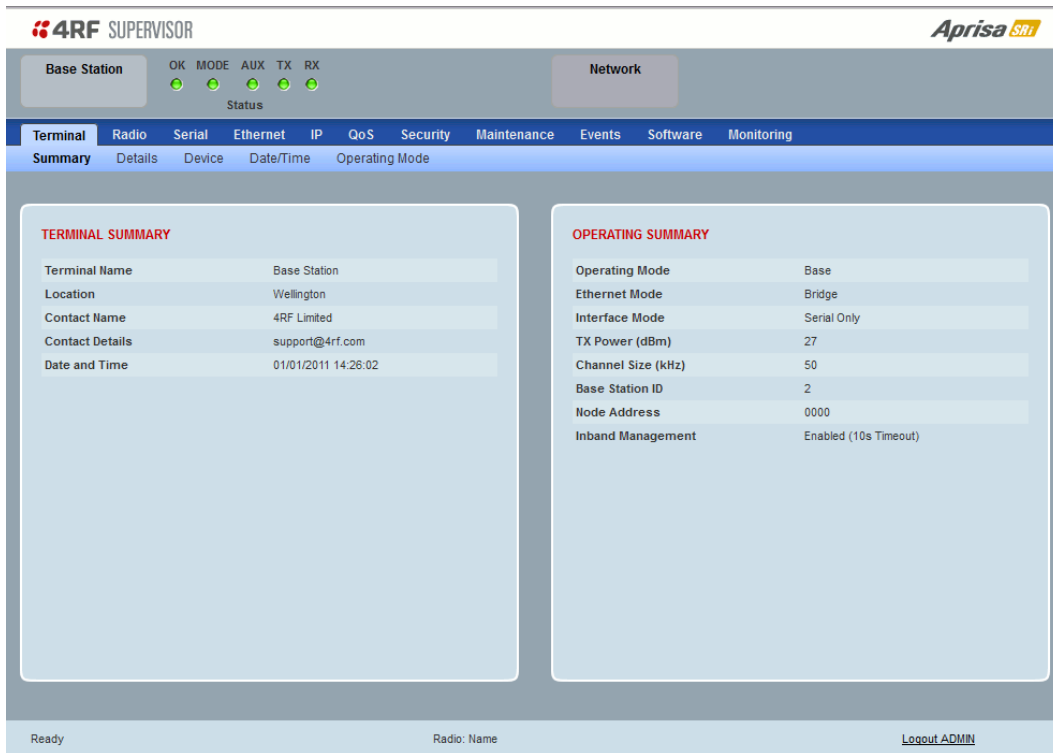
If the login is successful, the opening page will be displayed.



The screenshot shows the 4RF SUPERVISOR interface for a Base Station. The status bar at the top indicates 'OK' for MODE, AUX, TX, and RX. The main content area is divided into two summary sections:

TERMINAL SUMMARY	
Terminal Name	Base Station
Location	Wellington
Contact Name	4RF Limited
Contact Details	support@4rf.com
Date and Time	01/01/2011 14:28:02

OPERATING SUMMARY	
Operating Mode	Base
Ethernet Mode	Bridge
Interface Mode	Serial Only
TX Power (dBm)	27
Channel Size (kHz)	50
Base Station ID	2
Node Address	0000
Inband Management	Enabled (10s Timeout)

At the bottom of the interface, there is a 'Ready' status indicator, a 'Radio: Name' field, and a 'Logout ADMIN' button.

If there is more than one user logged into the same radio, the Multiple Management Sessions popup will show the usernames and IP addresses of the users. This popup message will display until 5 seconds after the cursor is moved. The event log will also record the users logged into the radio or logged out the radio.

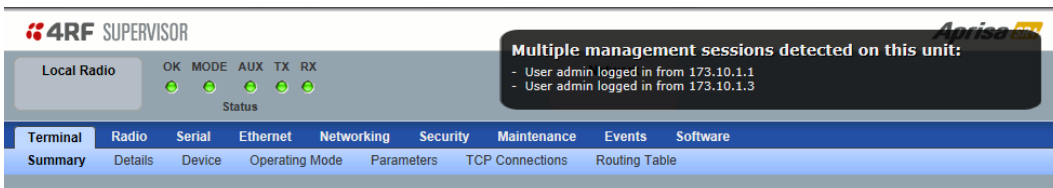

The screenshot shows the 4RF SUPERVISOR interface with a 'Local Radio' status. A black popup message is displayed in the top right corner:

**Multiple management sessions detected on this unit:**

- User admin logged in from 173.10.1.1
- User admin logged in from 173.10.1.3

The interface also shows a 'Status' bar with 'OK' for MODE, AUX, TX, and RX, and a navigation menu with options like Terminal, Radio, Serial, Ethernet, Networking, Security, Maintenance, Events, and Software.

## Logout of SuperVisor

As the maximum number of concurrent users that can be logged into a radio is 6, not logging out correctly can restrict access to the radio until after the timeout period (30 minutes).

Logging out from a radio will logout all users logged in with the same username.

If the SuperVisor window is closed without logging out, the radio will automatically log the user out after a timeout period of 3 minutes.

### To logout of SuperVisor:

Click on the 'Logout' button on the Summary Bar.

## SuperVisor Page Layout

### Standard Radio

The following shows the components of the SuperVisor page layout for a standard radio:

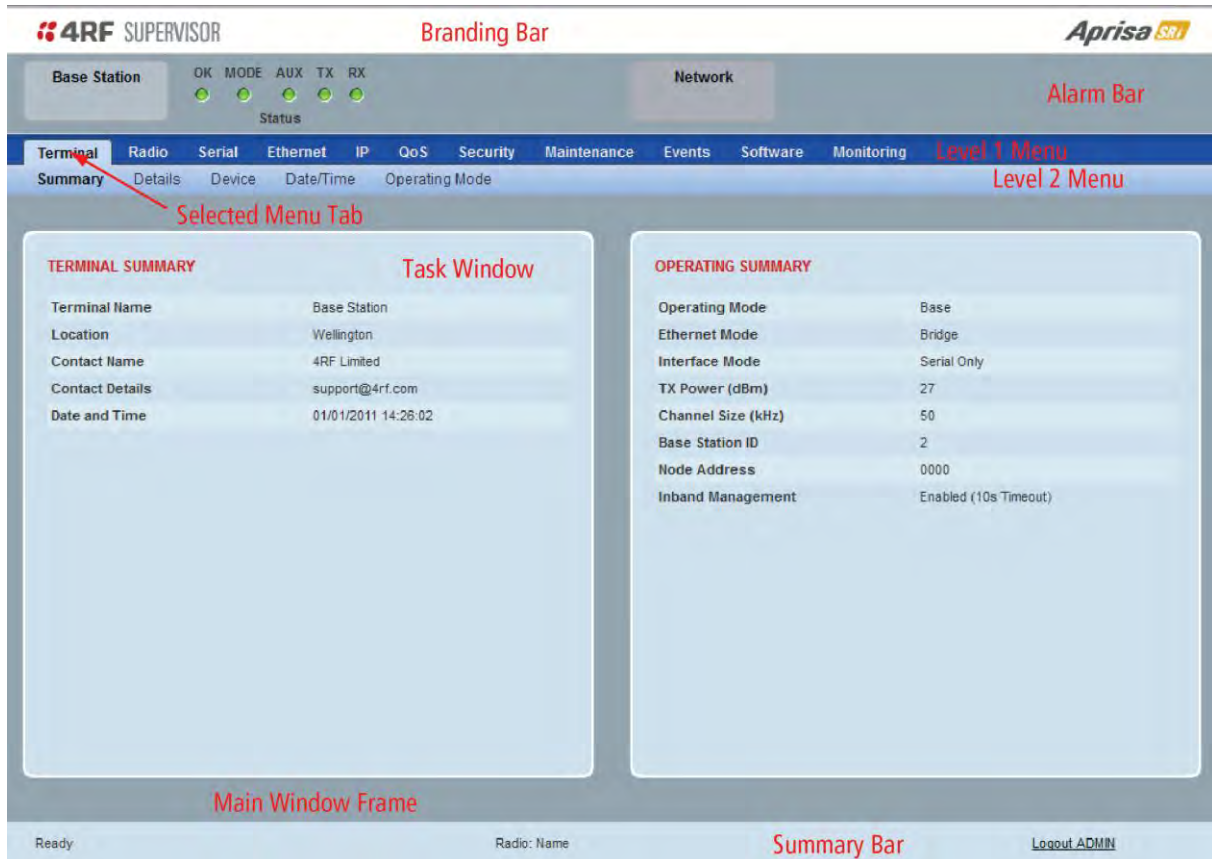

### SuperVisor Branding Bar



The branding bar at the top of the SuperVisor frame shows the branding of SuperVisor on the left and the product branding on the right.

### SuperVisor Alarm Bar



The alarm bar shows the name of the radio terminal that SuperVisor is logged into (the local radio) on the left.

If the local radio is a base station, the page shows the name of the current remote station (the remote radio) on the right. SuperVisor will manage all the remote stations in the network.

If the local radio is a remote station, the page shows the name of the remote station on the left. The right side of the Alarm Bar will be blank. SuperVisor manages only the remote station logged into.

The LED alarm indicators reflect the status of the front panel LEDs on the radio.

## SuperVisor Summary Bar

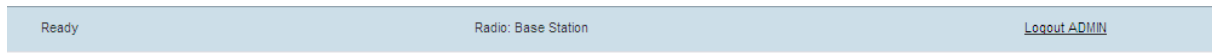

The summary bar at the bottom of the page shows:

Position	Function
Left	Busy - SuperVisor is busy retrieving data from the radio that SuperVisor is logged into. Ready - SuperVisor is ready to manage the radio.
Middle	Displays the name of the radio terminal that SuperVisor is currently managing.
Right	The access level logged into SuperVisor. This label also doubles as the SuperVisor logout button.

## SuperVisor Menu

The following is a list of SuperVisor top level menu items:

Local Terminal	Network
	Network Table
Terminal	Summary
Radio	Exceptions
Serial	View
Ethernet	
IP	
QoS	
Security	
Maintenance	
Events	
Software	
Monitoring	

### SuperVisor Parameter Settings

Changes to parameters settings have no effect until the 'Save' button is clicked.

Click the 'Save' button to apply the changes or 'Cancel' button to restore the current value.

## SuperVisor Menu Access

The SuperVisor menu has varying access levels dependent on the login User Privileges.

The following is a list of all possible SuperVisor menu items versus user privileges:

### *Terminal Settings Menu Items*

Menu Item	View	Technician	Engineer	Admin
Terminal > Summary	Read-Only	Read-Only	Read-Only	Read-Only
Terminal > Details	Read-Only	Read-Only	Read-Only	Read-Only
Terminal > Device	No Access	Read-Write	Read-Write	Read-Write
Terminal > Date / Time	Read-Only	Read-Only	Read-Only	Read-Only
Terminal > Operating Mode	No Access	Read-Write	Read-Write	Read-Write
Radio > Radio Summary	Read-Only	Read-Only	Read-Only	Read-Only
Radio > Channel Summary	Read-Only	Read-Only	Read-Only	Read-Only
Radio > Zone Summary	Read-Only	Read-Only	Read-Only	Read-Only
Radio > Radio Setup	No Access	Read-Write	Read-Write	Read-Write
Radio > Channel Setup	No Access	Read-Write	Read-Write	Read-Write
Radio > Zone Setup	No Access	Read-Write	Read-Write	Read-Write
Radio > Advanced Setup	No Access	Read-Write	Read-Write	Read-Write
Serial > Summary	Read-Only	Read-Only	Read-Only	Read-Only
Serial > Port Setup	No Access	Read-Write	Read-Write	Read-Write
Ethernet > Summary	Read-Only	Read-Only	Read-Only	Read-Only
Ethernet > Port Setup	No Access	Read-Write	Read-Write	Read-Write
Ethernet > L2 Filtering	No Access	No Access	Read-Write	Read-Write
Ethernet > VLAN	No Access	No Access	Read-Write	Read-Write
IP > IP Summary	Read-Only	Read-Only	Read-Only	Read-Only
IP > Terminal Server Summary	Read-Only	Read-Only	Read-Only	Read-Only
IP > IP Setup	No Access	Read-Write	Read-Write	Read-Write
IP > Terminal Server Setup	No Access	Read-Write	Read-Write	Read-Write
IP > L3 Filtering	No Access	No Access	Read-Write	Read-Write
IP > IP Routes	No Access	No Access	Read-Write	Read-Write
QoS > Summary	Read-Only	Read-Only	Read-Only	Read-Only
QoS > Traffic Priority	No Access	No Access	Read-Write	Read-Write
QoS > Traffic Classification	No Access	No Access	Read-Write	Read-Write
Security > Summary	Read-Only	Read-Only	Read-Only	Read-Only
Security > Setup	No Access	No Access	Read-Write	Read-Write
Security > Users	No Access	No Access	No Access	Read-Write
Security > RADIUS	No Access	No Access	No Access	Read-Write
Security > SNMP	No Access	No Access	No Access	Read-Write
Security > Manager	No Access	No Access	Read-Write	Read-Write
Security > Distribution	No Access	No Access	Read-Write	Read-Write
Maintenance > Summary	Read-Only	Read-Only	Read-Only	Read-Only

Menu Item	View	Technician	Engineer	Admin
Maintenance > General	No Access	Read-Write	Read-Write	Read-Write
Maintenance > Defaults	No Access	No Access	No Access	Read-Write
Maintenance > Licence	No Access	No Access	Read-Write	Read-Write
Maintenance > Advanced	No Access	No Access	Read-Write	Read-Write
Events > Alarm Summary	Read-Only	Read-Only	Read-Only	Read-Only
Events > Event History	Read-Only	Read-Only	Read-Only	Read-Only
Events > Events Setup	No Access	No Access	Read-Write	Read-Write
Events > Traps Setup	No Access	No Access	Read-Write	Read-Write
Events > Alarm I/O Setup	Read-Only	Read-Only	Read-Write	Read-Write
Events > Event Action Setup	No Access	No Access	Read-Write	Read-Write
Events > Defaults	No Access	No Access	Read-Write	Read-Write
Software > Summary	Read-Only	Read-Only	Read-Only	Read-Only
Software > Setup	No Access	No Access	Read-Write	Read-Write
Software > File Transfer	No Access	No Access	Read-Write	Read-Write
Software > Manager	No Access	No Access	Read-Write	Read-Write
Software > Remote Distribution	No Access	No Access	Read-Write	Read-Write
Software > Remote Activation	No Access	No Access	Read-Write	Read-Write
Monitoring > Terminal	Read-Only	Read-Only	Read-Only	Read-Only
Monitoring > Serial	Read-Only	Read-Only	Read-Only	Read-Only
Monitoring > Ethernet	Read-Only	Read-Only	Read-Only	Read-Only
Monitoring > Radio	Read-Only	Read-Only	Read-Only	Read-Only
Monitoring > User Selected	Read-Only	Read-Only	Read-Only	Read-Only
Monitoring > TCP Connections	Read-Only	Read-Only	Read-Only	Read-Only
Monitoring > Routing Table	Read-Only	Read-Only	Read-Only	Read-Only
Monitoring > Address Tables	Read-Only	Read-Only	Read-Only	Read-Only

#### Network Settings Menu Items

Menu Item	View	Technician	Engineer	Admin
Network Table	Read-Only	Read-Only	Read-Only	Read-Only
Summary	Read-Only	Read-Only	Read-Only	Read-Only
Exceptions	Read-Only	Read-Only	Read-Only	Read-Only
View	Read-Only	Read-Only	Read-Only	Read-Only

## Standard Radio

### Terminal

#### Terminal > Summary

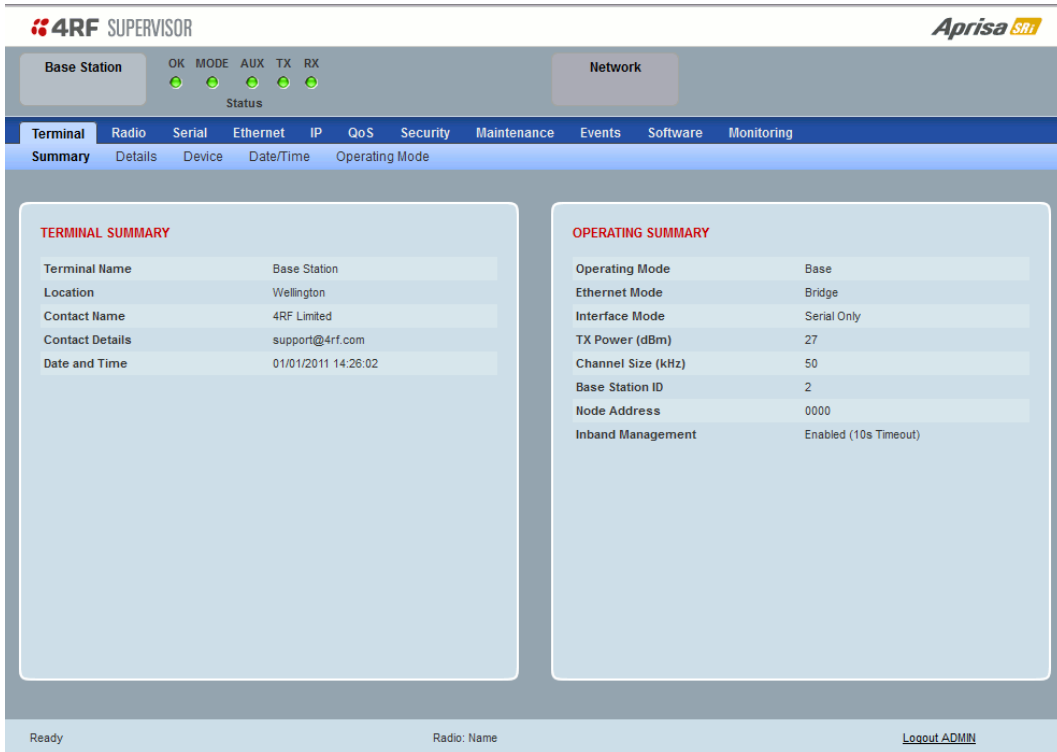

**4RF SUPERVISOR** **Aprisa SRI**

**Base Station** OK MODE AUX TX RX **Network**  
Status

**Terminal** Radio Serial Ethernet IP QoS Security Maintenance Events Software Monitoring  
Summary Details Device Date/Time Operating Mode

TERMINAL SUMMARY	
Terminal Name	Base Station
Location	Wellington
Contact Name	4RF Limited
Contact Details	support@4rf.com
Date and Time	01/01/2011 14:26:02

OPERATING SUMMARY	
Operating Mode	Base
Ethernet Mode	Bridge
Interface Mode	Serial Only
TX Power (dBm)	27
Channel Size (kHz)	50
Base Station ID	2
Node Address	0000
Inband Management	Enabled (10s Timeout)

Ready Radio: Name Logout ADMIN!

#### TERMINAL SUMMARY

This page displays the current settings for the Terminal parameters. See ‘Terminal > Details’ on page 80, ‘Terminal > Device’ on page 82 and ‘Terminal > Operating Mode’ on page 86 for setting details.

#### OPERATING SUMMARY

##### *Operating Mode*

This parameter displays the current Operating Mode i.e. if the radio is operating as a base station or remote station and the network operating mode of Bridge Mode or Router Mode.

##### *Interface Mode*

This parameter displays the Interfaces available for traffic on the radio such as Ethernet and Serial. For Ethernet availability on the radio see ‘Maintenance > Licence’ on page 191.

##### *TX Power (dBm)*

This parameter displays the current Transmit Power in dBm.

##### *Channel Size (kHz)*

This parameter displays the current Channel Size in kHz.



### *Base Station ID*

This parameter identifies the base station. All radios operating to the base station in the same network must use the same Base Station ID setting.

It is especially important to set different values for each network when two or more networks using the same frequencies are operating with some overlapping coverage. The entry is an integer from 1 to 8.

### *Node Address*

The Node Address of the base station is 0000.

If the Node Address shown is FFFE, this radio is a remote station but has not been registered with the base station.

The base station will automatically allocate a Node Address to all its registered remote station radios. This address can be between 000B to 01FE.

### *Inband Management*

This parameter displays the status of the Inband Management option.

### *Inband Management Timeout (sec)*

This parameter displays the number of seconds that the base station waits for a response from a remote station before aborting the Inband Management request.

## Terminal > Details

The screenshot shows the 4RF SUPERVISOR interface. At the top, there are status indicators for Base Station (OK, MODE, AUX, TX, RX) and Network. Below this is a navigation bar with tabs for Terminal, Radio, Serial, Ethernet, IP, QoS, Security, Maintenance, Events, Software, and Monitoring. Under the Terminal tab, there are sub-tabs for Summary, Details, Device, Date/Time, and Operating Mode. The main content area displays 'MANUFACTURING DETAILS' with the following information:

Radio Serial Number	R1310002548
Sub-Assembly Serial Number	13098777
HW Frequency Band	928-960MHz
HW Type	A
Ethernet Port 1 MAC Address	00:22:b2:10:39:62
Ethernet Port 2 MAC Address	00:22:b2:10:39:63
Active Software Version	1.0.0
Previous Software Version	Unknown

At the bottom of the interface, there are status indicators: 'Ready', 'Radio: Name', and a 'Logout ADMIN' link.

### MANUFACTURING DETAILS

#### *Radio Serial Number*

This parameter displays the Serial Number of the radio (shown on the enclosure label).



#### *Sub-Assembly Serial Number*

This parameter displays the Serial Number of the printed circuit board assembly (shown on the PCB label).



#### *HW Frequency Band*

This parameter displays the hardware radio frequency operating range.

#### *HW Type*

This parameter displays the hardware board assembly type.

#### *Radio MAC Address*

This parameter displays the MAC address of the radio (the management Ethernet MAC address).

#### *Active Software Version*

This parameter displays the version of the software currently operating the radio.

#### *Previous Software Version*

This parameter displays the software version that was running on the radio prior to the current software being activated.

A new radio from the factory will display 'None' for the Previous SW Version.

## Terminal &gt; Device

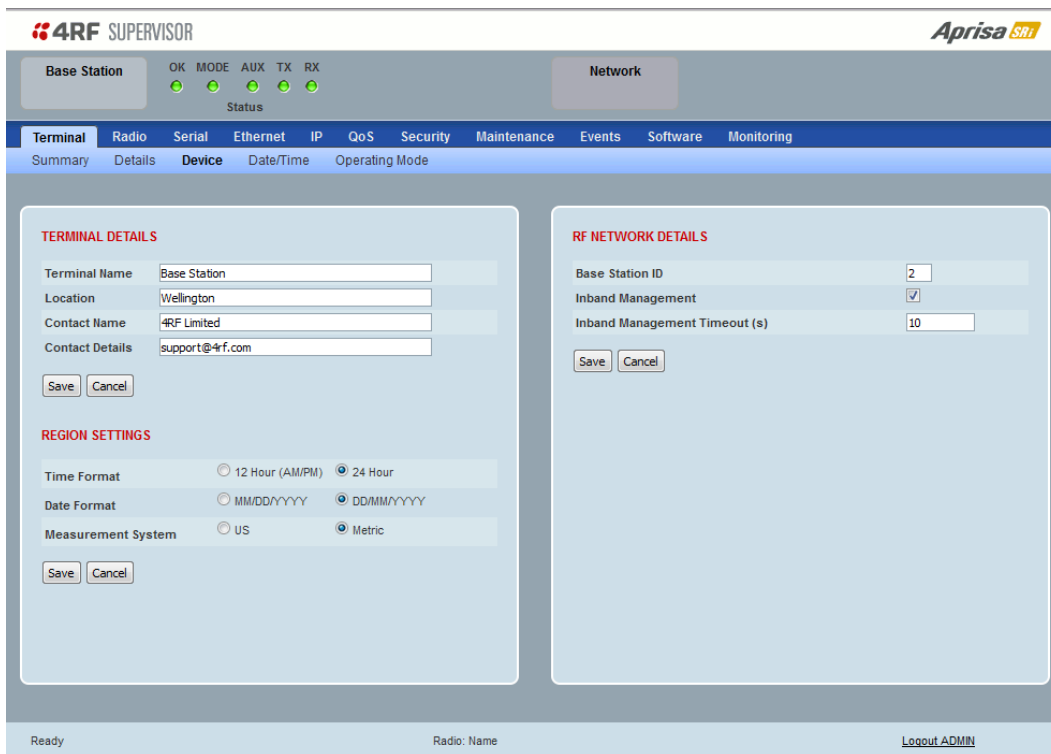

**4RF SUPERVISOR** **Aprisa SRI**

Base Station OK MODE AUX TX RX  
 Status

**Terminal** Radio Serial Ethernet IP QoS Security Maintenance Events Software Monitoring

Summary Details **Device** Date/Time Operating Mode

**TERMINAL DETAILS**

Terminal Name

Location

Contact Name

Contact Details

**REGION SETTINGS**

Time Format  12 Hour (AM/PM)  24 Hour

Date Format  MM/DD/YYYY  DD/MM/YYYY

Measurement System  US  Metric

**RF NETWORK DETAILS**

Base Station ID

Inband Management

Inband Management Timeout (s)

Ready Radio: Name [Logout ADMIN](#)

## TERMINAL DETAILS

The data entry in the next four fields can be up to 40 characters but cannot contain invalid characters. A popup warns of the invalid characters:

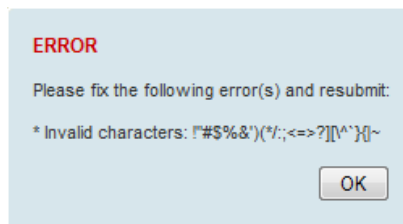

**ERROR**

Please fix the following error(s) and resubmit:

\* Invalid characters: !"#\$%&'()\*+,-<=>?[^\`}{|~

1. Enter the Terminal Name.
2. Enter the Location of the radio.
3. Enter a Contact Name. The default value is '4RF Limited'.
4. Enter the Contact Details. The default value is 'support@4RF.com'.

## RF NETWORK DETAILS

### *Network ID*

This parameter sets the network ID of this base station node and its remote stations in the network. The entry is four hexadecimal chars (not case sensitive).

The default setting is CAFE.

### *Base Station ID*

This parameter identifies the base station. All radios operating to the base station in the same network must use the same Base Station ID setting.

It is especially important to set different values for each network when two or more networks using the same frequencies are operating with some overlapping coverage. The entry is an integer from 1 to 8.

### *Inband Management*

This parameter sets the Inband Management option.

If the Inband Management option is enabled, SuperVisor operating on a base station can also manage all the remote stations in the network.

### *Inband Management Timeout (sec)*

This parameter sets the Inband Management timeout period. This determines the time the base station waits for a response from a remote before aborting the Inband Management request. The default setting is 10 seconds.

## REGION SETTINGS

### *Time Format*

This parameter sets the time format for all time based results.

The default setting is 24 Hours.

### *Date Format*

This parameter sets the date format for date based results.

The default setting is DD/MM/YYYY.

### *Measurement System*

This parameter sets the unit type for parameters like temperature readings.

The default setting is Metric.

Terminal > Date / Time

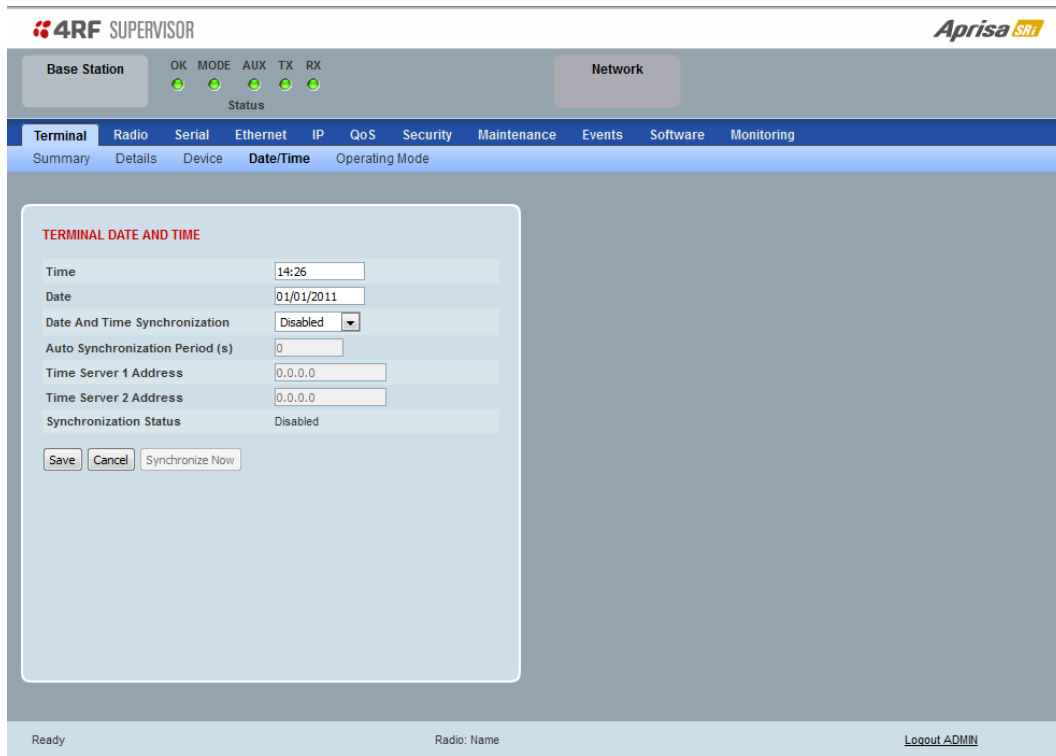

**TERMINAL DATE AND TIME**

Sets the Time and Date. This information is controlled from a software clock.

*Date and Time Synchronization*

This Date and Time Synchronization feature allows a radio to synchronize its date and time from an SNTP server. It would predominantly be used on the base station but could be used on a remote station.

Using the SNTP feature will ensure that all radios in the network has the same date and time required for accurate network diagnostics.

For high availability time/date synchronization, SNTP can be synchronized from two SNTP servers for server backup.

The default setting is Disabled.

Option	Function
Disabled	No SNTP Date and Time Synchronization
SNTP	Date and Time will be synchronized to a SNTP server

The base station periodically sends a broadcast message to the remote stations to synchronize the radio date and time.

#### *Auto Synchronization Period (s)*

This parameter sets the number of seconds between the end of the last synchronization and the next synchronization attempt. The minimum period is 60 seconds. A period of 0 seconds will disable synchronization attempts.

#### *Time Server 1 Address*

This parameter sets the IP address of the first priority SNTP server. If the synchronization is successful to this server, Time Server 2 Address will not be used.

#### *Time Server 2 Address*

This parameter sets the IP address of the second priority SNTP server. If the synchronization fails using the SNTP server on Time Server 1 Address, synchronization will be attempted to the SNTP server on this address.

#### *Synchronization Status*

This field shows the status of the current synchronization or the result of the last synchronization.

#### *Synchronize Now*

This Synchronize Now button provides manual Synchronization.

## Terminal &gt; Operating Mode

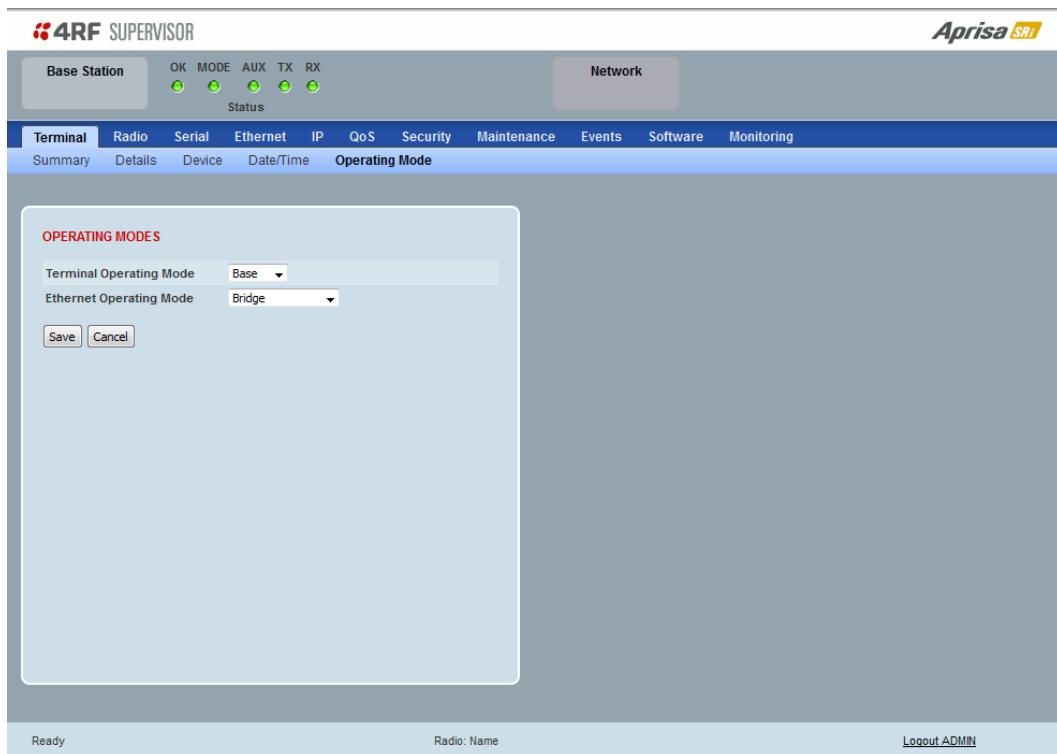

## OPERATING MODES

*Terminal Operating Mode*

The default setting is Remote.

Option	Function
Base	The base station manages all traffic activity between itself and remotes. It is the center-point of the network where in most cases will be connected to a SCADA master.
Remote	The remote in most cases is used as the end-point of the SCADA network connected to an RTU or PLC device for SCADA network control and monitoring.



### Ethernet Operating Mode

The Ethernet Operating Mode defines how Ethernet / IP traffic is processed in the radio. The default setting is Bridge.

Option	Function
Bridge	Bridge mode inspects each incoming Ethernet frame source and destination MAC addresses to determine if the frame is forwarded over the radio link or discarded.
Gateway Router	Gateway Router mode inspects each incoming IP source and destination IP addresses to determine if the packet is forwarded over the radio link or discarded. In this mode, all Ethernet interfaces have the same IP address and subnet.
Router	Router mode inspects each incoming IP source and destination IP addresses to determine if the packet is forwarded over the radio link or discarded. In this mode, each Ethernet interface has a different IP address and subnet.

## TERMINAL PROTECTION

### *Protection Type*

The Protection Type defines if a radio is a stand-alone radio or part of an Aprisa SRi Protected Station. The default setting is None.

Option	Function
None	The SRi radio is stand-alone radio (not part of an Aprisa SRi Protected Station).

# Radio

## Radio > Radio Summary

This page displays the current settings for the Radio parameters.

The screenshot shows the 4RF SUPERVISOR interface for the Aprisa SRi. The top navigation bar includes 'Terminal', 'Radio', 'Serial', 'Ethernet', 'IP', 'QoS', 'Security', 'Maintenance', 'Events', 'Software', and 'Monitoring'. The 'Radio' tab is active, and the 'Radio Summary' sub-tab is selected. The interface is divided into two main sections: 'TX POWER' and 'GENERAL'.

TX POWER	
TX Power (dBm)	23
TX Power Range (dBm)	7 to 23
TX Power Step Size (dB)	1

GENERAL	
Modem Mode	Mode A (FCC / IC)
Enhanced Noise Rejection Mode	Enabled
Channel Size (kHz)	50
Modulation Type	64QAM (Low Gain)
ACM Control	Disabled

At the bottom of the interface, the status is 'Ready', the radio name is 'Radio: Name', and there is a 'Logout ADMIN' link.

See 'Radio > Radio Setup' and 'Radio > Channel Setup' for setting details.

## Radio > Channel Summary

This page displays the current settings for the Channel parameters.

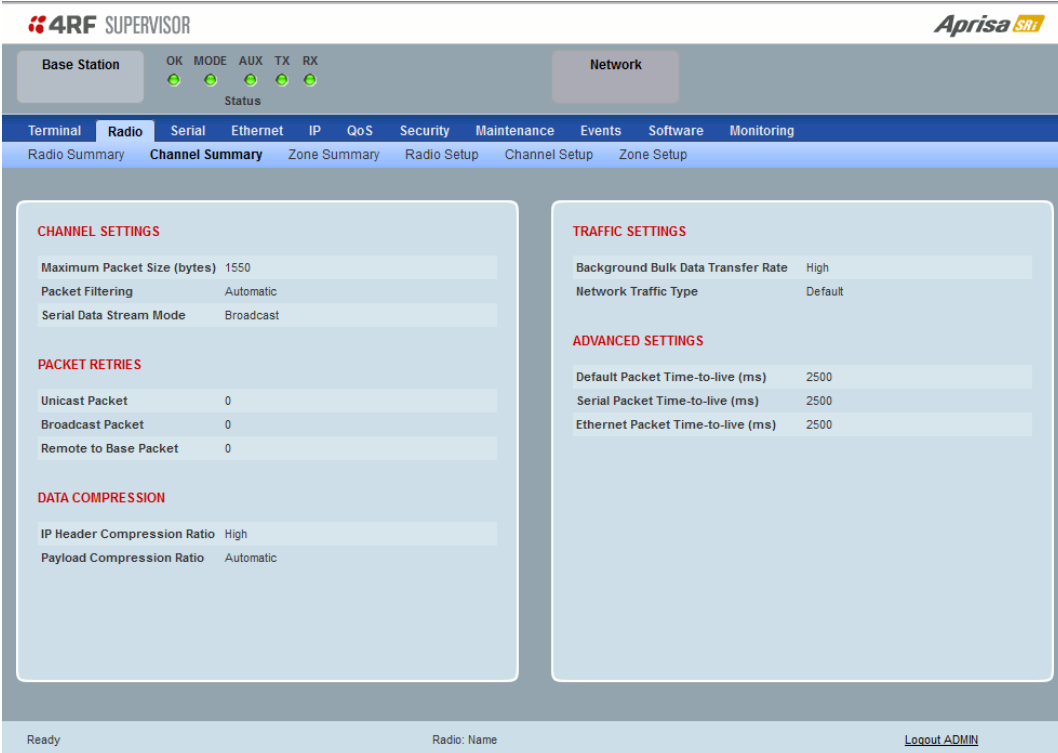

**4RF SUPERVISOR** **Aprisa SRI**

Base Station OK MODE AUX TX RX  
Status

Terminal **Radio** Serial Ethernet IP QoS Security Maintenance Events Software Monitoring

Radio Summary **Channel Summary** Zone Summary Radio Setup Channel Setup Zone Setup

**CHANNEL SETTINGS**

Maximum Packet Size (bytes) 1550

Packet Filtering Automatic

Serial Data Stream Mode Broadcast

**PACKET RETRIES**

Unicast Packet 0

Broadcast Packet 0

Remote to Base Packet 0

**DATA COMPRESSION**

IP Header Compression Ratio High

Payload Compression Ratio Automatic

**TRAFFIC SETTINGS**

Background Bulk Data Transfer Rate High

Network Traffic Type Default

**ADVANCED SETTINGS**

Default Packet Time-to-live (ms) 2500

Serial Packet Time-to-live (ms) 2500

Ethernet Packet Time-to-live (ms) 2500

Ready Radio: Name [Logout ADMIN](#)

See 'Radio > Channel Setup' for setting details.

### DATA COMPRESSION

#### *Payload Compression Ratio*

The payload is compressed using level 3 QuickLZ data compression. Payload Compression is automatic and cannot be turned off by SuperVisor.

Compression is not attempted on data that is already compressed e.g. jpg files.

## Radio > Zone Summary

This page displays the current settings for the Zones.

**4RF SUPERVISOR** **Aprisa SRi**

Base Station OK MODE AUX TX RX Network  
Status

Terminal **Radio** Serial Ethernet IP QoS Security Maintenance Events Software Monitoring

Radio Summary Channel Summary **Zone Summary** Radio Setup Channel Setup Zone Setup

**ZONE SUMMARY**

Zones	Zone 1	Zone 2	Zone 3	Zone 4	Zone 5	Zone 6	Zone 7	Zone 8
Zone	Enabled	Frequencies (MHz)	Channels Enabled					
1	<input checked="" type="checkbox"/>	902.5625 - 905.625	50 of 50					
2	<input checked="" type="checkbox"/>	905.6875 - 908.75	50 of 50					
3	<input checked="" type="checkbox"/>	908.8125 - 911.875	50 of 50					
4	<input checked="" type="checkbox"/>	911.9375 - 915	50 of 50					
5	<input checked="" type="checkbox"/>	915.0625 - 918.125	50 of 50					
6	<input checked="" type="checkbox"/>	918.1875 - 921.25	50 of 50					
7	<input checked="" type="checkbox"/>	921.3125 - 924.375	50 of 50					
8	<input checked="" type="checkbox"/>	924.4375 - 927.5	50 of 50					

400 channels enabled

Ready Radio: Name [Logout ADMIN](#)

See 'Radio > Channel Setup' for setting details.

### ZONE SUMMARY

#### *Zone*

The zone number defined in the regulatory specification. The maximum number of standard hop zones is 8.

#### *Enabled*

Displays the hop zones enabled.

#### *Frequencies*

Displays the zone frequencies defined for the zone hop number.

#### *Channels Enabled*

Displays the number of channels selected in the zone.

The Zone Summary > Zones shows the channels enabled per zone hop 1 to 8.

**4RF SUPERVISOR** **Aprisa SRi**

Base Station OK MODE AUX TX RX Network

Status

Terminal **Radio** Serial Ethernet IP QoS Security Maintenance Events Software Monitoring

Radio Summary Channel Summary **Zone Summary** Radio Setup Channel Setup Zone Setup

**ZONE SUMMARY**

Zones	Zone 1	Zone 2	Zone 3	Zone 4	Zone 5	Zone 6	Zone 7	Zone 8
1	<input checked="" type="checkbox"/>	<input checked="" type="checkbox"/>	<input checked="" type="checkbox"/>	<input checked="" type="checkbox"/>	<input checked="" type="checkbox"/>			
2	<input checked="" type="checkbox"/>	<input checked="" type="checkbox"/>	<input checked="" type="checkbox"/>	<input checked="" type="checkbox"/>	<input checked="" type="checkbox"/>			
3	<input checked="" type="checkbox"/>	<input checked="" type="checkbox"/>	<input checked="" type="checkbox"/>	<input checked="" type="checkbox"/>	<input checked="" type="checkbox"/>			
4	<input checked="" type="checkbox"/>	<input checked="" type="checkbox"/>	<input checked="" type="checkbox"/>	<input checked="" type="checkbox"/>	<input checked="" type="checkbox"/>			
5	<input checked="" type="checkbox"/>	<input checked="" type="checkbox"/>	<input checked="" type="checkbox"/>	<input checked="" type="checkbox"/>	<input checked="" type="checkbox"/>			
6	<input checked="" type="checkbox"/>	<input checked="" type="checkbox"/>	<input checked="" type="checkbox"/>	<input checked="" type="checkbox"/>	<input checked="" type="checkbox"/>			
7	<input checked="" type="checkbox"/>	<input checked="" type="checkbox"/>	<input checked="" type="checkbox"/>	<input checked="" type="checkbox"/>	<input checked="" type="checkbox"/>			
8	<input checked="" type="checkbox"/>	<input checked="" type="checkbox"/>	<input checked="" type="checkbox"/>	<input checked="" type="checkbox"/>	<input checked="" type="checkbox"/>			
9	<input checked="" type="checkbox"/>	<input checked="" type="checkbox"/>	<input checked="" type="checkbox"/>	<input checked="" type="checkbox"/>	<input checked="" type="checkbox"/>			
10	<input checked="" type="checkbox"/>	<input checked="" type="checkbox"/>	<input checked="" type="checkbox"/>	<input checked="" type="checkbox"/>	<input checked="" type="checkbox"/>			

Frequencies: 902.5625 - 905.625 Enabled: 50 of 50

Ready Radio: Name [Logout ADMIN](#)

## Radio > Radio Setup

Transmit frequency, maximum transmit power and channel size would normally be defined by a local regulatory body.

The screenshot shows the 'Radio Setup' configuration page in the 4RF SUPERVISOR interface. At the top, there are status indicators for Base Station (OK, MODE, AUX, TX, RX) and a Network section. Below the navigation tabs, the 'Radio Setup' page is active. It features two main configuration panels: 'TRANSMITTER' and 'MODEM'. The 'TRANSMITTER' panel includes a 'TX Power (dBm)' input field set to 23, with a note '(7 to 23 dBm, in 1 dB steps)', and a 'Channel Size (kHz)' dropdown menu set to 50. The 'MODEM' panel includes 'Modem Mode' (Mode A (FCC / IC)), 'Enhanced Noise Rejection Mode' (Enabled), 'Modulation Type' (64QAM (Low Gain)), and 'ACM Control' (Disabled). Both panels have 'Save' and 'Cancel' buttons. The bottom of the interface shows 'Ready', 'Radio: Name', and a 'Logout ADMIN' link.

### TRANSMITTER

#### *TX Power*

The transmitter power is the power measured at the antenna output port when transmitting. The transmitter power has a direct impact on the radio power consumption. The default setting is +26 dBm.

The maximum permitted transmitter power may be limited by the EIRP requirements. See 'Compliance Considerations' on page 46 for details.

If TX Power setting is higher than the high limit or lower than the low limit for the current modulation, an Informational Event (55 Terminal Unit Information) will be raised to notify the user that transmit power has been changed. This only applies to fixed modulation (not ACM).

---

**Note:** The Aprisa SRi transmitter contains power amplifier protection which allows the antenna to be disconnected from the antenna port without product damage.

---

### GENERAL

#### *Channel Size (kHz)*

This parameter sets the Channel Size for the radio (see 'Channel Sizes' on page 279 for Radio Capacities). The default setting is 50 kHz.

## MODEM

### *Modem Mode*

This parameter sets the Modem Mode in the radio. The Modem Mode option list is dependent on the radio Hardware Variant (defined by the part number ordered).

HW Variant	Option	Channel Sizes
915 MHz	Mode A (FCC)	50 kHz

### *Enhanced Noise Rejection Mode*

This parameter enables / disables the Enhanced Noise Rejection Mode in the radio. This feature improves co-channel interference performance at strong receiver signal levels. All radios in an Aprisa SRi network must use the same setting i.e. enabled or disabled.

The default setting is Enabled.

### *Modulation Type*

The remote to base direction of transmission is always fixed i.e. not adaptive.

This parameter sets the fixed TX Modulation Type for the base to remote direction.

Option	Function
QPSK (Low Gain)	Sets the modulation to QPSK with Min Coded FEC.
16QAM (Low Gain)	Sets the modulation to 16 QAM with Min Coded FEC.
64QAM (Low Gain)	Sets the modulation to 64 QAM with Min Coded FEC.

The default setting is QPSK (Low Gain).

The base station radio TX modulation will be set based on the worse case (RSSI) path profile scenario of all the radios in one hop distance from the base station radio.



### ACM Control (base station)

This parameter enables / disables Adaptive Code Modulation for the remote to base direction of transmission (upstream).

When ACM is enabled, the base station sends a modulation type recommendation to each remote radio based on the signal quality for each individual remote radio.

Option	Function
Disabled	Disables Adaptive Code Modulation for the upstream. The base station does not send a modulation type recommendation to any remote radio.
Standard	Enables Adaptive Code Modulation for the upstream. The ACM will be selected based on the link quality.

The default setting is Standard.

### *ACM Control (remote station)*

These settings are only used if the Modulation Type is set to Adaptive and only apply to the remote to base direction of transmission (upstream).

The remote to base direction of transmission can be adaptive modulation or fixed modulation.

This parameter sets the TX Modulation Type for the remote station radio.

Option	Function
Adaptive	Sets the modulation type to Adaptive Code Modulation. The remote radio receives the modulation type recommendation from the base and adjusts the modulation and FEC code rate in the remote to base direction of transmission (upstream).
QPSK (Low Gain)	Sets the modulation to QPSK with Min Coded FEC.
16QAM (Low Gain)	Sets the modulation to 16 QAM with Min Coded FEC.
64QAM (Low Gain)	Sets the modulation to 64 QAM with Min Coded FEC.

## Radio &gt; Channel Setup

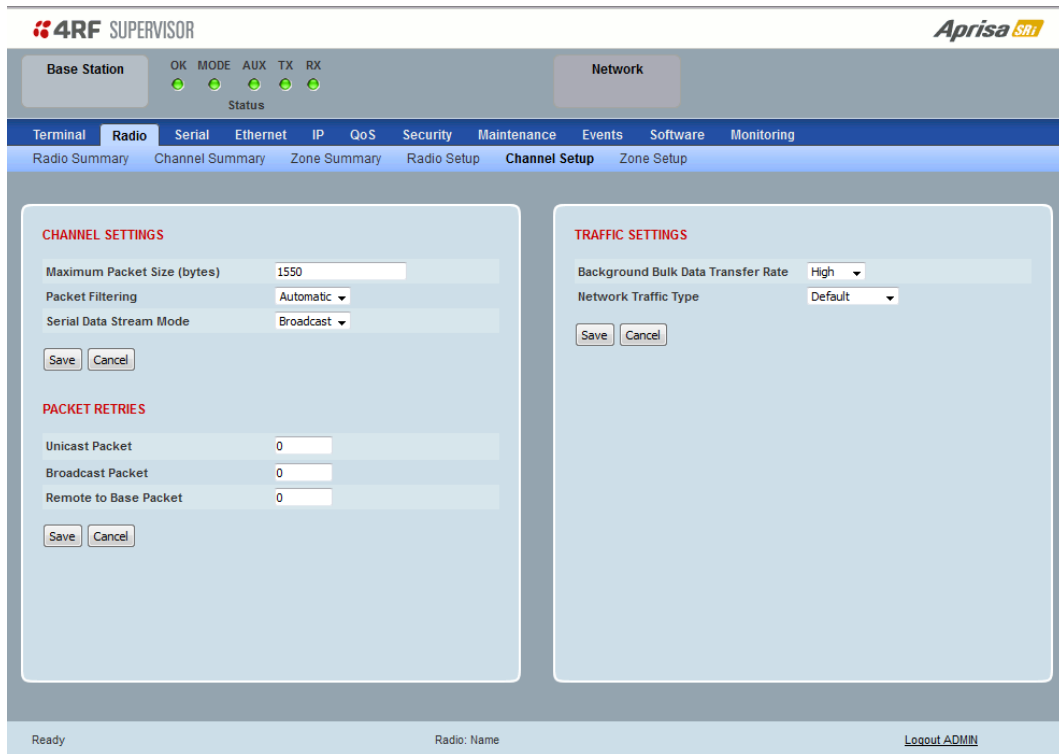

## CHANNEL SETTINGS

*Maximum Packet Size (Bytes)*

This parameter sets the maximum over-the-air packet size in bytes. A smaller maximum Packet Size is beneficial when many remote stations are trying to access the channel. The default setting is 1550 bytes.

As radios dispatched from the factory have a Packet Size set to the maximum value of 1550 bytes, if a new radio is installed in an existing network, the Packet Size must be changed to ensure it is the same value for all radios in the network. The new radio will not register an existing network if the Packet Size is not the same as the other radios in the network.

This packet size includes the wireless protocol header and security payload (0 to 16 bytes). The length of the security header depends on the level of security selected.

When the security setting is 0, the maximum user data transfer over-the-air is 1516 bytes.

When encryption is enabled, the entire packet of user data (payload) is encrypted. If authentication is being used, the security frame will be added (up to 16 bytes). The wireless protocol header is then added which is proprietary to the Aprisa SRi. This is not encrypted.

### Packet Filtering

Each Aprisa SRi radio can filter packets not destined for itself. The Packet Filtering parameter controls this functionality.

In an Aprisa SRi network, all communication from remote stations is destined for the base station in the Aprisa SRi network communication protocol.

Option	Function
Disabled	Every packet received by the radio will be forwarded to the relevant interface.
Automatic	The radio will filter (discard) packets not destined for itself according to the Aprisa SRi traffic protocols

The default setting is Automatic.

---

**Note:** The Aprisa SRi network is transparent to the protocol being transmitted; therefore the Packet Filtering parameter is based on the Aprisa SRi addressing and network protocols, not the user (SCADA, etc.) traffic protocols.

---

### Serial Data Stream Mode

This parameter controls the traffic flow in the radio serial ports.

Option	Function
Broadcast	Serial port traffic from the network is broadcast on all serial ports on this radio. This will include the RS-232 port derived from the USB port.
Segregate	Serial port traffic from the network from a specific port number is directed to the respective serial port only (see Segregated Port Directions).

The default setting is Broadcast.

## PACKET RETRIES

The larger the number of retries, the greater the chance the packet will be delivered but reduces overall packet throughput.

### *Unicast Packet*

Sets the number of unicast packet retries for the radio.

#### Base Station

The base station unicast packet retries sets the number of retries for a packet sent to remote radios.

#### Remote Radios

The remote radio unicast packet sets the number of retries for a packet sent to the base station.

If the Auto is ticked, remote radios will use the unicast packet retries setting sent from the base station

If the Auto is unticked, remote radios will use the unicast packet retries set on the remote radio.

### *Broadcast Packet*

The base station broadcast packet retries sets the number of broadcast packet retries for packets sent to all remote radios.

### *Remote To Base Packet*

Sets all remote radio unicast packet retries setting if the remote radio unicast packet Auto is ticked.

## TRAFFIC SETTINGS

### *Background Bulk Data Transfer Rate*

This parameter sets the data transfer rate for large amounts of management data.

Option	Function
High	Utilizes more of the available capacity for large amounts of management data. Highest impact on user traffic.
Medium	Utilizes a moderate of the available capacity for large amounts of management data. Medium impact on user traffic.
Low	Utilizes a minimal of the available capacity for large amounts of management data. Lowest impact on user traffic.

The default setting is high.

### *Network Traffic Type*

This parameter optimizes the channel settings for the predominant traffic type.

Option	Function
User Defined	<p>Allows the user to define the channel settings (see 'Radio &gt; Advanced Setup' on page 104).</p> <div data-bbox="663 981 1193 1182" style="border: 1px solid #ccc; padding: 10px; margin: 10px 0;"> <p><b>INFORMATION</b></p> <p>For "User Defined" network traffic type, more parameters are available for configuration in the Advanced Setup menu.</p> <p style="text-align: right;"><input type="button" value="OK"/></p> </div>
Serial Only	Optimizes the channel settings for the predominantly serial traffic.
Ethernet Only	Optimizes the channel settings for the predominantly Ethernet traffic.
Mixed	Optimizes the channel settings for a mix of Ethernet and serial traffic.

The default setting is Mixed.

## Radio > Zone Setup

This page configures the Zone / Channel settings.

**4RF SUPERVISOR** **Aprisa SRi**

Base Station: OK, MODE, AUX, TX, RX (Status: OK)

Network

Terminal | **Radio** | Serial | Ethernet | IP | QoS | Security | Maintenance | Events | Software | Monitoring

Radio Summary | Channel Summary | Zone Summary | Radio Setup | Channel Setup | **Zone Setup**

**ZONE SETUP**

Zones	Zone 1	Zone 2	Zone 3	Zone 4	Zone 5	Zone 6	Zone 7	Zone 8
Zone	Enabled	Frequencies (MHz)	Channels Enabled					
1	<input checked="" type="checkbox"/>	902.5625 - 905.625	50 of 50					
2	<input checked="" type="checkbox"/>	905.6875 - 908.75	50 of 50					
3	<input checked="" type="checkbox"/>	908.8125 - 911.875	50 of 50					
4	<input checked="" type="checkbox"/>	911.9375 - 915	50 of 50					
5	<input checked="" type="checkbox"/>	915.0625 - 918.125	50 of 50					
6	<input checked="" type="checkbox"/>	918.1875 - 921.25	50 of 50					
7	<input checked="" type="checkbox"/>	921.3125 - 924.375	50 of 50					
8	<input checked="" type="checkbox"/>	924.4375 - 927.5	50 of 50					

400 channels enabled

Ready Radio: Name [Logout ADMIN](#)

### ZONE SETUP

Specific channels within the selected zone hop can be disabled if there is a known transmission within the channel that may cause interference to the operation of this network. The minimum number of enabled channels is 50.

Initially, remote radio channels are enabled to allow communication with the base station.

When a remote radio registers with the base station, the remote radio will automatically configure to use the zone channel list distributed by the base station. The zone channels displayed on the remote radio will continue to display the radio channels initially enabled (not the zone channel list distributed by the base station).

#### *Zone*

The zone number from 1 to 8.

#### *Enabled*

Enables / disables the entire hop zone of channels. If a channel is selected in a zone that is disabled, the zone will be enabled when the channel selection is saved. The default is all zones enabled.

### *Frequencies*

The zone frequencies are pre-defined in the Aprisa SRi for the zone number. The zone frequencies are spaced at the hop frequency of 62.5 kHz.

### *Channels Enabled*

Displays the number of channels selected in the zone.

### **Controls**

The Enable All button enables all zones and all channels in each zone.

The Disable All button disables all zones and all channels in each zone.



The Zone Setup > Zones 1 to 8 setup the channels per zone hop.

**4RF SUPERVISOR** **Aprisa SRi**

Base Station OK MODE AUX TX RX Network

Status

Terminal **Radio** Serial Ethernet IP QoS Security Maintenance Events Software Monitoring

Radio Summary Channel Summary Zone Summary Radio Setup Channel Setup **Zone Setup**

**ZONE SETUP**

Zones	Zone 1	Zone 2	Zone 3	Zone 4	Zone 5	Zone 6	Zone 7	Zone 8
1	<input checked="" type="checkbox"/>	<input checked="" type="checkbox"/>	<input checked="" type="checkbox"/>	<input checked="" type="checkbox"/>	<input checked="" type="checkbox"/>			
2	<input checked="" type="checkbox"/>	<input checked="" type="checkbox"/>	<input checked="" type="checkbox"/>	<input checked="" type="checkbox"/>	<input checked="" type="checkbox"/>			
3	<input checked="" type="checkbox"/>	<input checked="" type="checkbox"/>	<input checked="" type="checkbox"/>	<input checked="" type="checkbox"/>	<input checked="" type="checkbox"/>			
4	<input checked="" type="checkbox"/>	<input checked="" type="checkbox"/>	<input checked="" type="checkbox"/>	<input checked="" type="checkbox"/>	<input checked="" type="checkbox"/>			
5	<input checked="" type="checkbox"/>	<input checked="" type="checkbox"/>	<input checked="" type="checkbox"/>	<input checked="" type="checkbox"/>	<input checked="" type="checkbox"/>			
6	<input checked="" type="checkbox"/>	<input checked="" type="checkbox"/>	<input checked="" type="checkbox"/>	<input checked="" type="checkbox"/>	<input checked="" type="checkbox"/>			
7	<input checked="" type="checkbox"/>	<input checked="" type="checkbox"/>	<input checked="" type="checkbox"/>	<input checked="" type="checkbox"/>	<input checked="" type="checkbox"/>			
8	<input checked="" type="checkbox"/>	<input checked="" type="checkbox"/>	<input checked="" type="checkbox"/>	<input checked="" type="checkbox"/>	<input checked="" type="checkbox"/>			
9	<input checked="" type="checkbox"/>	<input checked="" type="checkbox"/>	<input checked="" type="checkbox"/>	<input checked="" type="checkbox"/>	<input checked="" type="checkbox"/>			
10	<input checked="" type="checkbox"/>	<input checked="" type="checkbox"/>	<input checked="" type="checkbox"/>	<input checked="" type="checkbox"/>	<input checked="" type="checkbox"/>			

Frequencies: 902.5625 - 905.625 Enabled: 50 of 50

Ready Radio: Name [Logout ADMIN](#)

## ZONE SETUP

Specific channels within the selected zone hop can be disabled if there is a known transmission within the channel that may cause interference to the operation of this network. The minimum number of enabled channels is 50.

Initially, remote radio channels are enabled to allow communication with the base station.

When a remote radio registers with the base station, the remote radio will automatically configure to use the zone channel list distributed by the base station. The zone channels displayed on the remote radio will continue to display the radio channels initially enabled (not the zone channel list distributed by the base station).

## Controls

The Enable All button enables all channels in the zone.

The disable All button disables all channels in the zone.

## Radio &gt; Advanced Setup

This page is only visible when the Channel Setup > Network Traffic Type is set to User Defined.

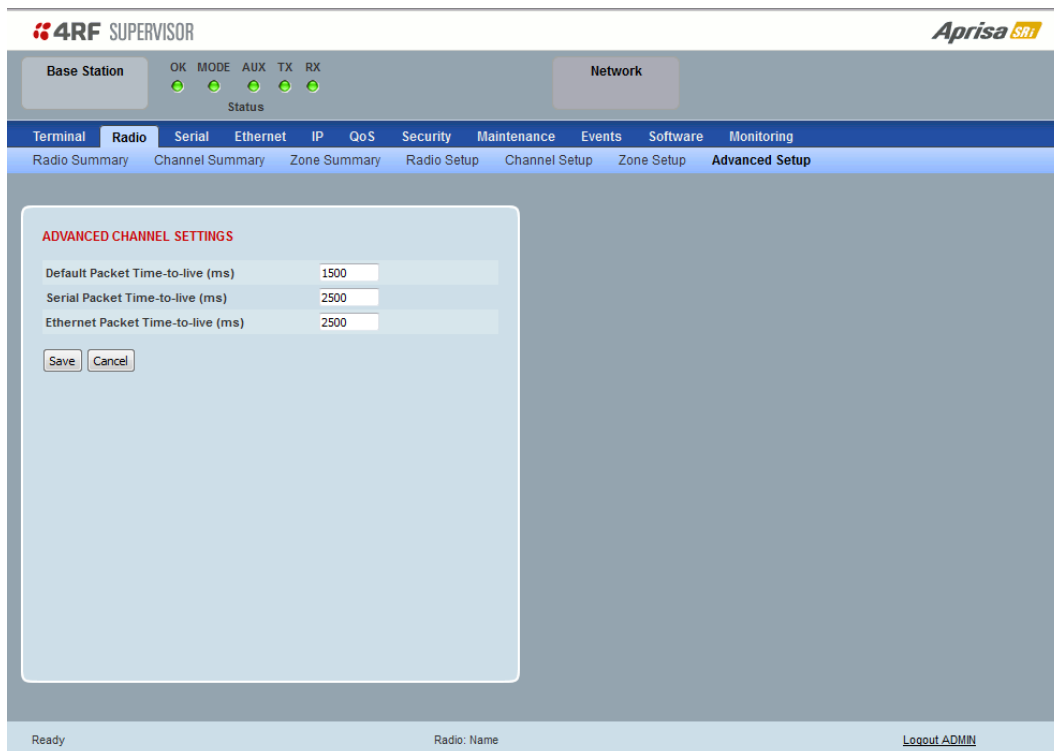

## ADVANCED CHANNEL SETTINGS

*Default Packet Time to Live (ms)*

This parameter sets the default time a packet is allowed to live in the system before being dropped if it cannot be transmitted over the air. It is used to prevent old, redundant packets being transmitted through the Aprisa SRi network. The default setting is 1500 ms.

In the case of serial poll SCADA networks such as MODBUS and IEC 60870.50.101, it is important to ensure the replies from the RTU are in the correct sequence and are not timed out replies from Master requests. If the TTL value is too long, the SCADA master will detect sequence errors.

It is recommended to use a TTL which is half the serial SCADA timeout. This is commonly called the 'scan timeout' or 'link layer time out' or 'retry timeout'.

When using TCP protocols, a TTL of 1500 ms is recommended because a TCP re-transmission usually occurs after approximately 3 seconds.

In SCADA networks which use both serial and Ethernet, it is recommended that the TTL is set to half the serial SCADA timeout for serial remotes, and 1500 ms for Ethernet (TCP) remotes. For example, if the serial SCADA timeout is 1000 ms, a remote radio which is connected to the serial RTU should be set to 500 ms, a remote radio which is connected to an Ethernet (TCP) RTU should have a 1500 ms timeout.

In this case, the base station TTL should be set to 1500 ms as well; or whichever is the longer TTL of serial or Ethernet.

#### *Serial Packet Time to Live (ms)*

This parameter sets the time a serial packet is allowed to live in the system before being dropped if it cannot be transmitted over the air. The default setting is 800 ms.

#### *Ethernet Packet Time to Live (ms)*

This parameter sets the time an Ethernet packet is allowed to live in the system before being dropped if it cannot be transmitted over the air. The default setting is 600 ms.

## Serial

### Serial > Summary

#### RS-232 Hardware Ports

This page displays the current settings for the serial port parameters.

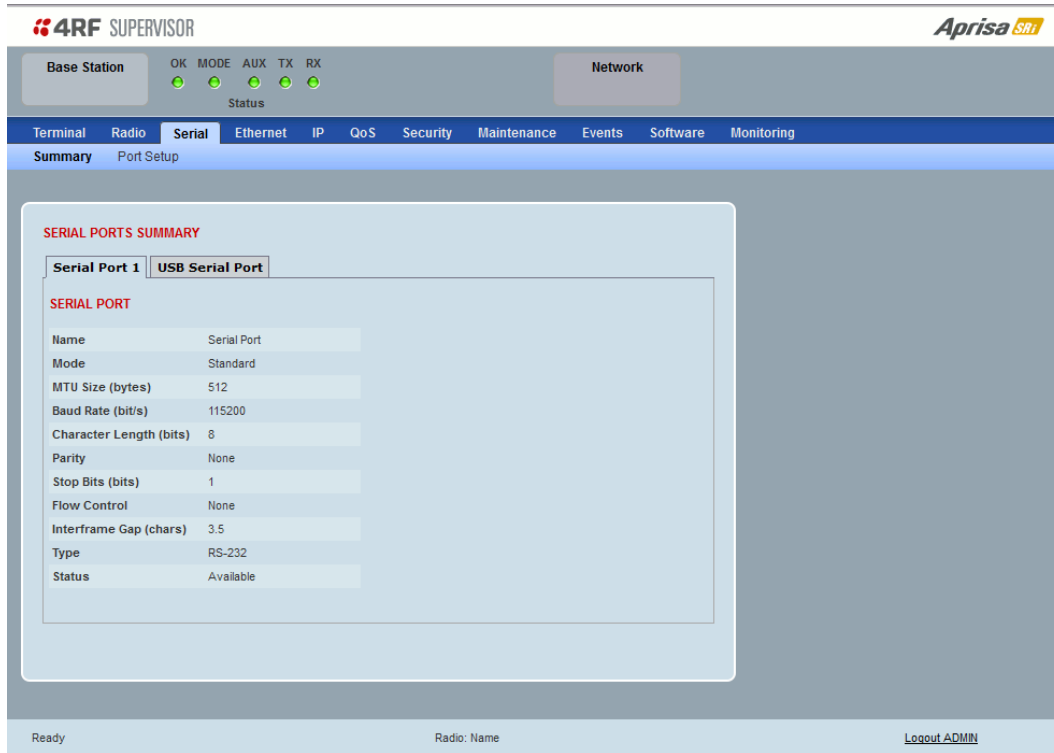

**4RF SUPERVISOR** **Aprisa SRI**

Base Station OK MODE AUX TX RX Network

Status

Terminal Radio **Serial** Ethernet IP QoS Security Maintenance Events Software Monitoring

Summary Port Setup

**SERIAL PORTS SUMMARY**

Serial Port 1 **USB Serial Port**

**SERIAL PORT**

Name	Serial Port
Mode	Standard
MTU Size (bytes)	512
Baud Rate (bit/s)	115200
Character Length (bits)	8
Parity	None
Stop Bits (bits)	1
Flow Control	None
Interframe Gap (chars)	3.5
Type	RS-232
Status	Available

Ready Radio: Name [Logout ADMIN](#)

See 'Serial > Port Setup' on page 108 for configuration options.

## USB Serial Ports

This page displays the current settings for the USB serial port parameters.

The screenshot shows the 4RF SUPERVISOR web interface. At the top, there are status indicators for Base Station (OK, MODE, AUX, TX, RX) and Network. The main navigation bar includes Terminal, Radio, Serial (selected), Ethernet, IP, QoS, Security, Maintenance, Events, Software, and Monitoring. Under the Serial tab, there are sub-tabs for Summary and Port Setup. The main content area displays the 'SERIAL PORTS SUMMARY' for 'Serial Port 1' (USB Serial Port). The settings are as follows:

SERIAL PORT	
Name	USB Serial Port
Mode	Standard
MTU Size (bytes)	512
Baud Rate (bit/s)	115200
Character Length (bits)	8
Parity	None
Stop Bits (bits)	1
Flow Control	None
Interframe Gap (chars)	3.5
Type	RS-232
Status	Not Detected

At the bottom of the interface, there is a 'Ready' status, 'Radio: Name', and a 'Logout ADMIN' link.

### Type

This parameter displays the Serial Port interface type.

If the Name is USB Serial Port:

Option	Function
RS-232	Indicates that a USB to RS-232 serial converter is plugged into the radio.
RS-485	Indicates that a USB to RS-485 serial converter is plugged into the radio.

## Serial > Port Setup

### RS-232 Hardware Ports

This page provides the setup for the serial port settings.

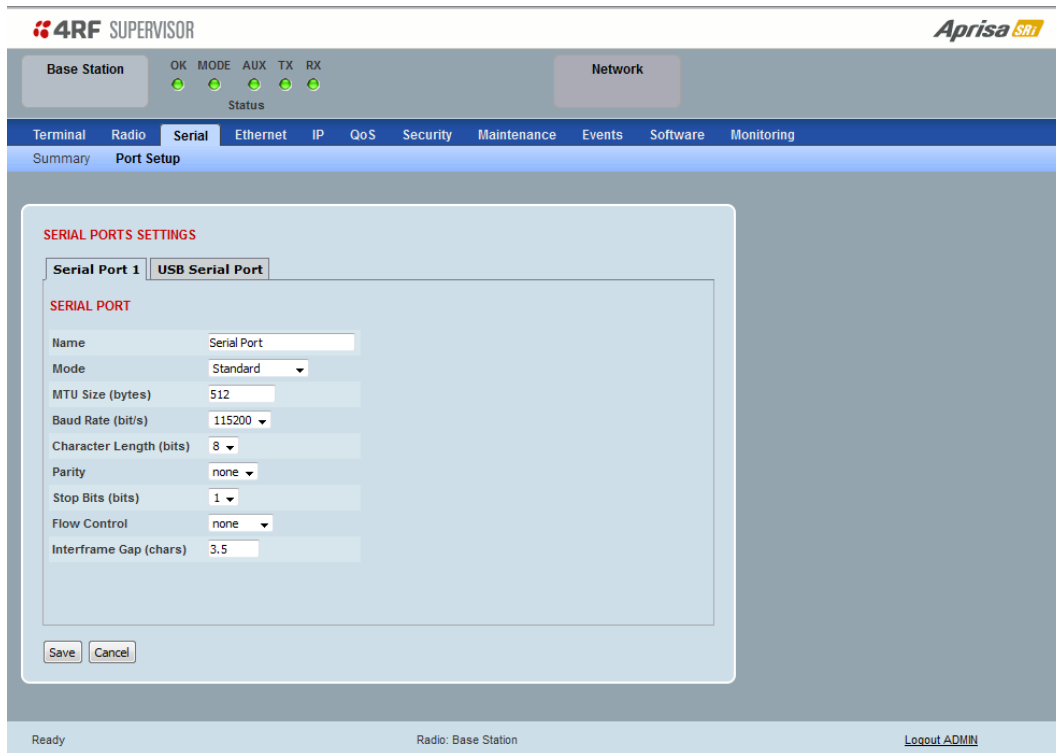

### SERIAL PORTS SETTINGS

#### Name

This parameter sets the port name which can be up to 32 characters.

Option	Function
Serial Port	This is the normal RS-232 serial ports provided with the RJ45 connector.
USB Serial Port	This is the optional RS-232 / RS-485 serial port provided with the USB host port connector with a USB to RS-232 / RS-485 RJ45 converter cable (see 'USB Serial Ports' on page 261).

### Mode

This parameter defines the mode of operation of the serial port. The default setting is Standard.

Option	Function
Disabled	The serial port is not required.
Standard	The serial port is communicating with serial ports on other stations.
Terminal Server	A base station Ethernet port can communicate with both Ethernet ports and serial ports on remote stations. RS-232 traffic is encapsulated in IP packets (see 'Serial > Port Setup' Terminal Server on page 111).
SLIP	IP packets are encapsulated over RS-232 interface port (see 'Serial > Port Setup' Serial Line Interface Protocol (SLIP)' on page 113).

### MTU Size (bytes)

This parameter sets the size of the packet in bytes received before it is transmitted if an inter-frame gap is not detected. The default setting is 512 bytes.

### Baud Rate (bit/s)

This parameter sets the baud rate to 300, 600, 1200, 2400, 4800, 9600, 19200, 38400, 57600 or 115200 bit/s. The default setting is 115200 bit/s.

### Character Length (bits)

This parameter sets the character length to 7 or 8 bits. The default setting is 8 bits.

### Parity

This parameter sets the parity to Even, Odd or None. The default setting is None.

### Stop Bits (bits)

This parameter sets the number of stop bits to 1 or 2 bits. The default setting is 1 bit.

### Flow Control

This parameter sets the flow control of the serial port. The default setting is Disabled.

Option	Function
None	The Aprisa SRi radio port (DCE) CTS is in a permanent ON (+ve) state. This does not go to OFF if the radio link fails.
CTS-RTS	CTS / RTS hardware flow control between the DTE and the Aprisa SRi radio port (DCE) is enabled. If the Aprisa SRi buffer is full, the CTS goes OFF. In the case of radio link failure the signal goes to OFF (-ve) state.

In terminal server mode, the serial packet is no different from an Ethernet packet and travels through various packet queues before being transmitted over the air. Thus, the serial flow control has no affect in terminal server mode.

### Inter-Frame Gap (chars)

This parameter defines the gap between successive serial data frames. It is used to delimit the serial data to define the end of a packet. The Inter-Frame Gap limits are 0 to 20 chars in steps of 0.1 char. The default setting is 3.5 chars.



## Terminal Server

This menu item is only applicable if the serial port has an operating mode of Terminal Server.

The Terminal Server operating mode provides encapsulation of serial data into an IP packet (over TCP or UDP).

A server connected to a base station Ethernet port can communicate with all remote station Ethernet ports and serial ports.

**SERIAL PORTS SETTINGS**

Serial Port 1 | USB Serial Port

SERIAL PORT		TERMINAL SERVER	
Name	Serial Port	Name	Terminal Server 1
Mode	Terminal Server	Local Address	172.10.1.22
MTU Size (bytes)	512	Local Port	20000
Baud Rate (bit/s)	115200	Remote Address	0.0.0.0
Character Length (bits)	8	Remote Port	0
Parity	none	Protocol	TCP
Stop Bits (bits)	1	Mode	Server
Flow Control	none	Inactivity Timeout (sec)	300
Interframe Gap (chars)	3.5	TCP (Keep Alive)	<input type="checkbox"/>

Save Cancel

Ready Radio: Base Station Logout ADMIN

### Local Address

This parameter displays the IP address of this radio.

### Local Port

This parameter sets the TCP or UDP port number of the local serial port.

The valid port number range is greater than or equal to 1024 and less than or equal to 49151 but with exclusions of 0, 5445, 6445, 9930 or 9931. The default setting is 20000.

### Remote Address

This parameter sets the IP address of the server connected to the radio Ethernet port.

### Remote Port

This parameter sets the TCP or UDP port number of the server connected to the radio Ethernet port. The default setting is 0.

### Protocol

This parameter sets the L4 TCP/IP or UDP/IP protocol used for terminal server operation. The default setting is TCP.

### Mode

This parameter defines the mode of operation of the terminal server connection. The default setting is Client and Server.

Option	Function
Client	The radio will attempt to establish a TCP connection with the specified remote unit. Generally, this setting is for the base station with an Ethernet connection to the SCADA master.
Server	The radio will listen for a TCP connection on the specified local port. Generally, this setting is for the remote station with a serial connection to the RTU. Data received from any client shall be forwarded to the associated serial port while data received from that serial port shall be forwarded to every client with an open TCP connection. If no existing TCP connections exist, all data received from the associated serial port shall be discarded.
Client and Server	The radio will listen for a TCP connection on the specified local port and if necessary, establish a TCP connection with the specified remote unit. Generally, this setting is used for the remote station but it should be used carefully as two connections might be established with the base station. Data received from any client shall be forwarded to the associated serial port while data received from that serial port shall be forwarded to every client with an open TCP connection.

### Inactivity Timeout (seconds)

This specifies the duration (in seconds) to automatically terminate the connection with the remote TCP server if no data has been received from either the remote TCP server or its associated serial port for the duration of the configured inactivity time.

### TCP Keep Alive

A TCP keep alive is a message sent by one device to another to check that the link between the two is operating, or to prevent the link from being broken.

If the TCP keep alive is enabled, the radio will be notified if the TCP connection fails.

If the TCP keep alive is disabled, the radio relies on the Inactivity Timeout to detect a TCP connection failure. The default setting is disabled.

---

**Note:** An active TCP keep alive will generate a small amount of extra network traffic.

---

## Serial Line Interface Protocol (SLIP)

This menu item is only applicable if the serial port has an operating mode of SLIP.

The SLIP operating mode provides IP packet encapsulation over RS-232 serial interface as per the SLIP protocol RFC 1055.

A SLIP serial interface contains the IP address of the serially connected RTU as per the RTU/PLC SLIP protocol. The SLIP interfaces on the remote radios can be part of the bridge network and can coexist and operate with a mix of Ethernet interfaces, serial SLIP and terminal server interfaces.

As the RTU/PLC serial SLIP interface doesn't support MAC addresses, a remote radio SLIP interface uses a proxy ARP function that returns its own MAC address for ARP requests based on the IP address of the RTU/PLC SLIP interface.

The screenshot shows the 'SERIAL PORTS SETTINGS' window in the 4RF SUPERVISOR interface. The window is titled 'Serial Port 1' and 'USB Serial Port'. It contains two columns of settings: 'SERIAL PORT' and 'SLIP'. The 'SERIAL PORT' column includes fields for Name (Serial Port), Mode (SLIP), MTU Size (bytes) (512), Baud Rate (bit/s) (115200), Character Length (bits) (8), Parity (none), Stop Bits (bits) (1), Flow Control (none), and Interframe Gap (chars) (3.5). The 'SLIP' column includes a field for Serial Device IP Address (0.0.0.0). At the bottom of the window are 'Save' and 'Cancel' buttons. The interface also shows a status bar at the bottom with 'Ready', 'Radio: Base Station', and a 'Logout ADMIN' link.

### Serial Device IP Address

This parameter sets the IP address of the RTU connected on the configured serial port.

### Baud Rate (bit/s)

This parameter sets the baud rate to 1200, 2400, 4800, 9600, 19200, 38400, 57600 or 115200 bit/s. The default setting is 115200 bit/s. The minimum supported baud rate is 1200 bit/s as SLIP will not work on baud rates below 1200.

### USB Serial Ports

This page provides the setup for the USB serial port settings.

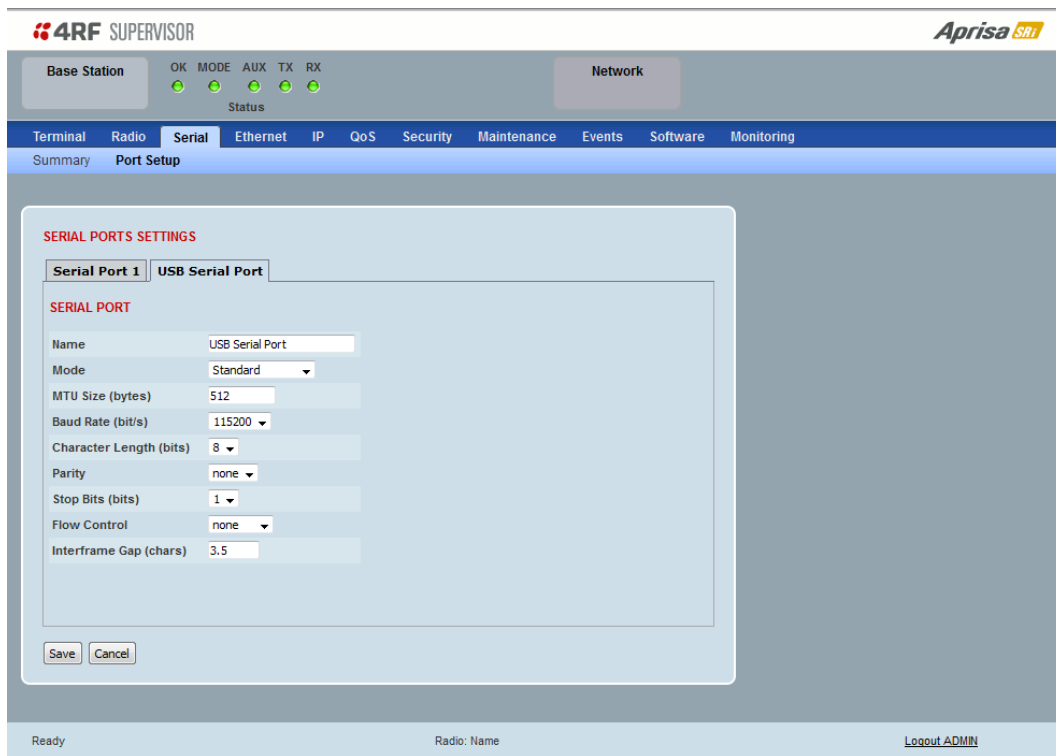

### SERIAL PORTS SETTINGS

#### Mode

This parameter defines the mode of operation of the serial port. The default setting is Disabled.

Option	Function
Disabled	The serial port is not required.
Standard	The serial port is communicating with serial ports on other stations.
Terminal Server	A base station Ethernet port can communicate with both Ethernet ports and serial ports on remote stations. RS-232 traffic is encapsulated in IP packets (see ‘Serial > Port Setup’ Terminal Server on page 111).
CLI Management	The USB host port is used to access the radio Command Line Interface (CLI). A USB converter to RS-232 convertor will be required to connect to a PC.

#### MTU Size (bytes)

This parameter sets the size of the packet in bytes received before it is transmitted if an inter-frame gap is not detected. The default setting is 512 bytes.

#### Baud Rate (bit/s)

This parameter sets the baud rate to 300, 600, 1200, 2400, 4800, 9600, 19200, 38400, 57600 or 115200 bit/s. The default setting is 115200 bit/s.

### *Character Length (bits)*

This parameter sets the character length to 7 or 8 bits. The default setting is 8 bits.

### *Parity*

This parameter sets the parity to Even, Odd or None. The default setting is None.

### *Stop Bits (bits)*

This parameter sets the number of stop bits to 1 or 2 bits. The default setting is 1 bit.

### *Flow Control*

This parameter sets the flow control of the serial port. The default setting is Disabled.

Option	Function
None	The Aprisa SRi radio port (DCE) CTS is in a permanent ON (+ve) state. This does not go to OFF if the radio link fails.
CTS-RTS	CTS / RTS hardware flow control between the DTE and the Aprisa SRi radio port (DCE) is enabled. If the Aprisa SRi buffer is full, the CTS goes OFF. In the case of radio link failure the signal goes to OFF (-ve) state.

In terminal server mode, the serial packet is no different from an Ethernet packet and travels through various packet queues before being transmitted over the air. Thus, the serial flow control has no affect in terminal server mode.

### *Inter-Frame Gap (chars)*

This parameter defines the gap between successive serial data frames. It is used to delimit the serial data to define the end of a packet. The Inter-Frame Gap limits are 0 to 20 chars in steps of 0.1 char. The default setting is 3.5 chars.

## Ethernet

### Ethernet > Summary

This page displays the current settings for the Ethernet port parameters and the status of the ports.

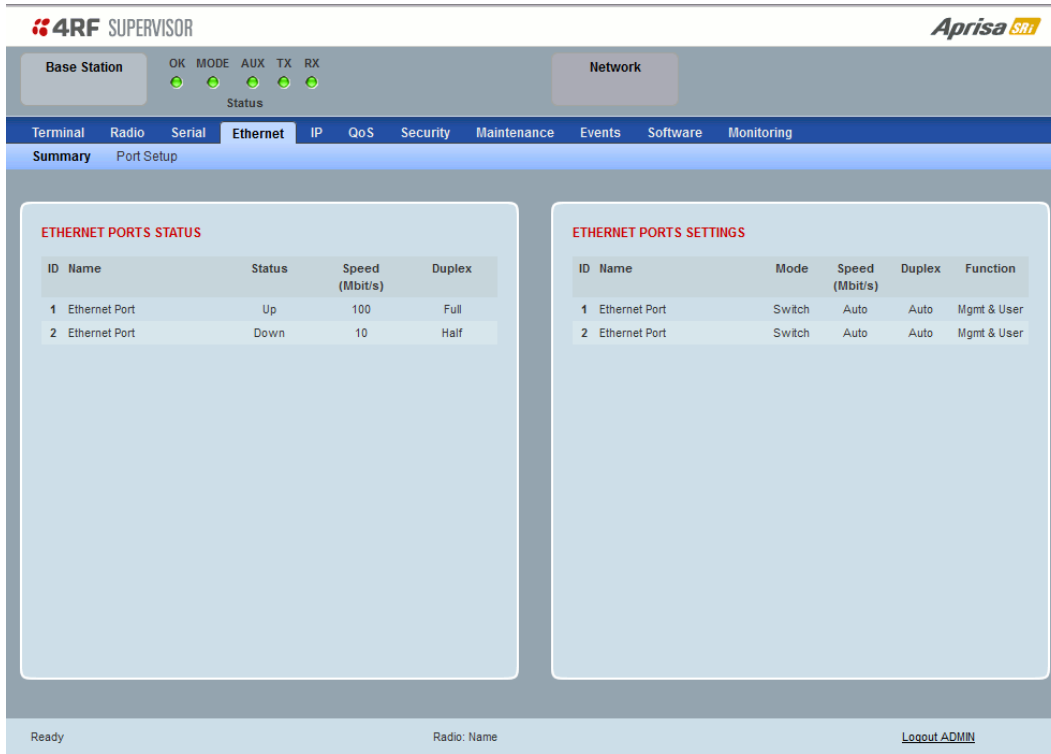

The screenshot shows the 4RF SUPERVISOR interface for an Aprisa SRi device. The top navigation bar includes 'Base Station' and 'Network'. The 'Base Station' section shows status indicators for OK, MODE, AUX, TX, and RX, all of which are green. The 'Network' section is active, showing a menu with 'Ethernet' selected. Below the menu, there are two main panels: 'ETHERNET PORTS STATUS' and 'ETHERNET PORTS SETTINGS'.

**ETHERNET PORTS STATUS**

ID	Name	Status	Speed (Mbit/s)	Duplex
1	Ethernet Port	Up	100	Full
2	Ethernet Port	Down	10	Half

**ETHERNET PORTS SETTINGS**

ID	Name	Mode	Speed (Mbit/s)	Duplex	Function
1	Ethernet Port	Switch	Auto	Auto	Mgmt & User
2	Ethernet Port	Switch	Auto	Auto	Mgmt & User

At the bottom of the interface, there is a status bar with 'Ready', 'Radio: Name', and a 'Logout ADMIN' link.

See 'Ethernet > Port Setup' for configuration options.

## Ethernet > Port Setup

This page provides the setup for the Ethernet ports settings.

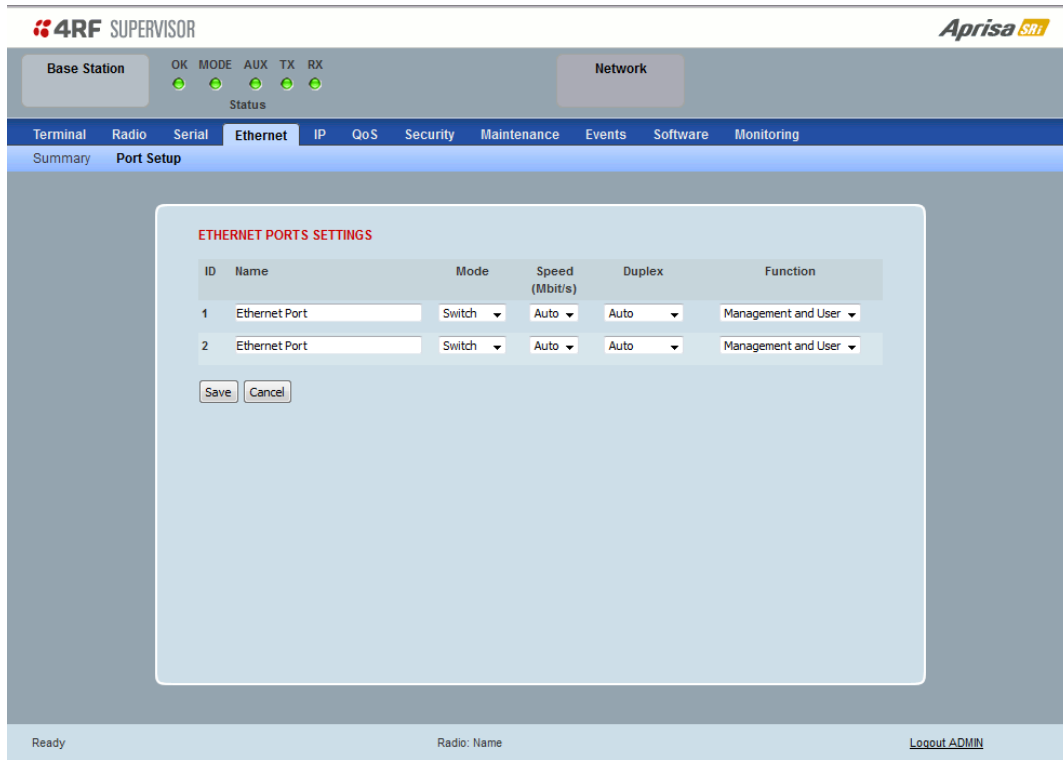

### ETHERNET PORT SETTINGS

#### Mode

This parameter controls the Ethernet traffic flow. The default setting is Standard.

Option	Function
Standard	Enables Ethernet data communication over the radio link but Ethernet traffic is not switched locally between the two Ethernet ports.
Switch	Ethernet traffic is switched locally between the two Ethernet ports and communicated over the radio link
Disabled	Disables all Ethernet data communications.

### *Speed (Mbit/s)*

This parameter controls the traffic rate of the Ethernet port. The default setting is Auto.

Option	Function
Auto	Provides auto selection of Ethernet Port Speed 10/100 Mbit/s
10	The Ethernet Port Speed is manually set to 10 Mbit/s
100	The Ethernet Port Speed is manually set to 100 Mbit/s

### *Duplex*

This parameter controls the transmission mode of the Ethernet port. The default setting is Auto.

Option	Function
Auto	Provides auto selection of Ethernet Port duplex setting.
Half Duplex	The Ethernet Port is manually set to Half Duplex.
Full Duplex	The Ethernet Port is manually set to Full Duplex.

### *Function*

This parameter controls the use for the Ethernet port. The default setting is Management and User.

Option	Function
Management Only	The Ethernet port is only used for management of the network.
Management and User	The Ethernet port is used for management of the network and User traffic over the radio link.
User Only	The Ethernet port is only used for User traffic over the radio link.



## Ethernet > L2 Filtering

This page is only available if the Ethernet traffic option has been licensed (see ‘Maintenance > Licence’ on page 191).

The screenshot shows the 4RF SUPERVISOR interface. At the top, there's a 'Base Station' status bar with indicators for OK, MODE, AUX, TX, and RX. Below that is a navigation menu with tabs for Terminal, Radio, Serial, Ethernet (selected), IP, QoS, Security, Maintenance, Events, Software, and Monitoring. Under the Ethernet tab, there are sub-tabs for Summary, Port Setup, L2 Filtering (selected), and VLAN. The main content area is titled 'L2 Filtering' and contains two sections:

**FILTER DETAILS**

Select	Rule Id	Source MAC Address	Destination MAC Address	Protocol Type
<input type="radio"/>	1	00:01:50:c2:01:00	ff:ff:ff:ff:ff:ff	ARP
<input type="radio"/>	2	00:01:50:c2:01:00	00:01:50:c2:01:02	Any
<input type="radio"/>	3	00:01:50:c2:01:00	fe:ff:ff:ff:ff:ff	VLAN

Below the table are buttons for 'Save', 'Delete', and 'Cancel'.

**ADD NEW FILTER**

Rule Id	Source MAC Address	Destination MAC Address	Protocol Type
<input type="text"/>	<input type="text"/>	<input type="text"/>	Any

Below this table are buttons for 'Add' and 'Cancel'.

At the bottom of the interface, there's a status bar with 'Ready', 'Radio: Name', and a 'Logout ADMIN!' link.

### FILTER DETAILS

L2 Filtering provides the ability to filter (white list) radio link user traffic based on specified Layer 2 MAC addresses.

User traffic originating from specified Source MAC Addresses destined for specified Destination MAC Addresses that meets the protocol type criteria will be transmitted over the radio link.

User traffic that does not meet the filtering criteria will not be transmitted over the radio link.

Management traffic to the radio will never be blocked.

#### Source MAC Address

This parameter sets the filter to the Source MAC address of the packet in the format ‘hh:hh:hh:hh:hh:hh’.

If the Source MAC Address is set to ‘FF:FF:FF:FF:FF:FF’, traffic will be accepted from any source MAC address.

#### Destination MAC Address

This parameter sets the filter to the Destination MAC address of the packet in the format ‘hh:hh:hh:hh:hh:hh’.

If the Destination MAC Address is set to ‘FF:FF:FF:FF:FF:FF’, traffic will be delivered to any destination MAC address.

### Protocol Type

This parameter sets the EtherType accepted ARP, VLAN, IPv4, IPv6 or Any type.

Example:

In the screen shot, the rules are configured in the base station which controls the Ethernet traffic to the radio link.

Traffic from an external device with the Source MAC address 00:01:50:c2:01:00 is forwarded over the radio link if it meets the criteria. All other traffic will be blocked.

- Rule 1 If the Protocol Type is ARP going to any destination MAC address or
- Rule 2 If the Protocol Type is Any and the destination MAC address is 01:00:50:c2:01:02 or
- Rule 3 If the Protocol Type is VLAN tagged packets going to any unicast destination MAC address.

### Special L2 Filtering Rules:

#### Unicast Only Traffic

This L2 filtering allows for Unicast only traffic and drop broadcast and multicast traffic. This filtering is achieved by adding the two rules:

Rule	Source MAC Address	Destination MAC Address	Protocol Type
Allow ARPS	FF:FF:FF:FF:FF:FF	FF:FF:FF:FF:FF:FF	ARP
Allow Unicasts from Any source	FF:FF:FF:FF:FF:FF	FE:FF:FF:FF:FF:FF	Any

#### To delete a L2 Filter:

1. Click on an existing rule 'Select'.
2. Click on Delete.

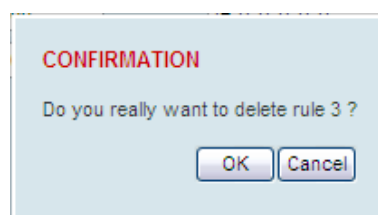

3. Click on OK.

#### ADD NEW FILTER

#### To add a L2 Filter:

1. Enter the Rule ID number. This is a unique rule number between 1 and 25.
2. Enter the Source MAC address of the packet or 'FF:FF:FF:FF:FF:FF' to accept traffic from any MAC address.
3. Enter the Destination MAC address of the packet or 'FF:FF:FF:FF:FF:FF' to deliver traffic to any MAC address.
4. Select the Protocol Type to ARP, VLAN, IPv4, IPv6 or Any type.
5. Click on Add.

## Ethernet > VLAN

This page is only available if the Ethernet traffic option has been licensed (see 'Maintenance > Licence' on page 191).

### VLAN PORT SETTINGS - All Ports

This page specifies the parameters that relate to all Ethernet ports when working in Bridge Mode. Three parameters are global parameters for the Ethernet Bridge; enable / disable VLANs, Management VLAN ID and the Double VLAN ID(S-VLAN) and the priority bit. These parameters can't be defined per port and are globally defined for the Ethernet Bridge.

#### *VLAN Enabled*

This parameter sets if VLAN operation is required on the network. If it is enabled on the base station, it must also be enabled on the remote stations. The default is disabled.

#### *Management VLAN*

This parameter sets the VLAN ID for management traffic only. The value can be between 1 and 4094. The default is 1.

#### *Double Tag Egress S-VLAN ID*

This parameter sets the S-VLAN ID (outer tag) in the egress direction. The value can be between 1 and 4094. The default is 1.

### Double Tag Egress S-VLAN Priority

This parameter sets the S-VLAN egress traffic priority. The default is Priority 1 (Best Effort).

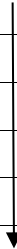
Option	Egress Priority Classification	High / Low Priority
Priority 0 Background	0	Lowest Priority
Priority 1 (Best Effort)	1	
Priority 2 (Excellent Effort)	2	
Priority 3 (Critical Applications)	3	
Priority 4 (Video)	4	
Priority 5 (Voice)	5	
Priority 6 (Internetwork Control)	6	
Priority 7 (Network Control)	7	

## VLAN PORT SETTINGS - Port 1

This example is shown for the product option of 2E2S i.e. two Ethernet ports.

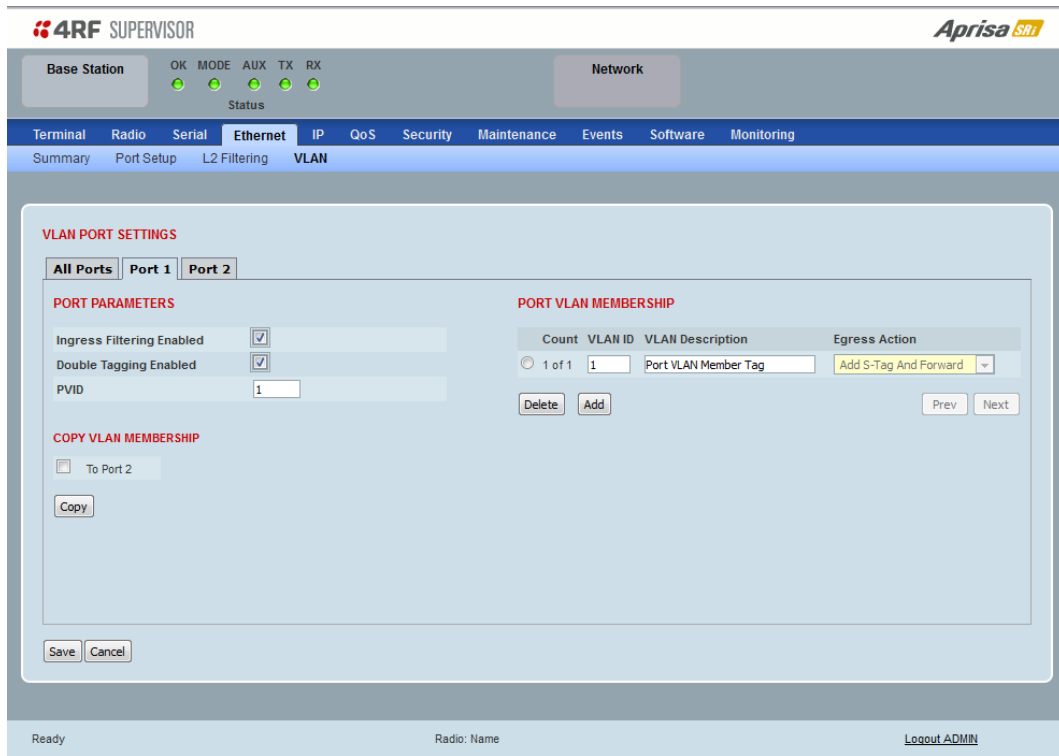

## PORT PARAMETERS

### *Ingress Filtering Enabled*

This parameter enables ingress filtering. When enabled, if ingress VLAN ID is not included in its member set (inner tagged), the frame will be discarded.

If the Ingress Filtering is disabled, the Aprisa SRi supports 'Admit All Frames' so that all frames tagged, untagged and priority-tagged-frames are allowed to pass through the Ethernet ports. The default is disabled.

### *Double Tagging Enabled*

This parameter enables double tagging on this specific port. When enabled, if the ingress traffic is double tagged, the Aprisa SRi will check and validate that the S-VLAN ID matches the S-VLAN defined in 'Double Tag Egress S-VLAN ID' in the 'all ports' tab. If there is a match, the packet will be forwarded into the Bridge and the S-VLAN outer tag will be removed, thus the radio network will only forward a single VLAN. If there isn't a matching S-VLAN, the packet will be discarded. On egress, the outer tag (S-VLAN) is appended with the 'Double Tag Egress S-VLAN ID' defined in the 'all ports' tab (see page 121). The default is disabled.

If double tagging is enabled on the port, incoming frames should always be double tagged.

- If the incoming frame is untagged, then the PVID (port VLAN ID) is used and forwarded with the Port Ingress priority provided the PVID is configured in the Port VLAN Membership of any of the Ethernet ports. If not, the frames are dropped.
- If the incoming frame is single tagged, then PVID is used and forwarded with the Port Ingress priority provided the PVID is configured in the Port VLAN Membership of any of the Ethernet ports. If not the frames are dropped.

If double tagging is disabled on the port, incoming frames should always be single tagged, untagged or priority-tagged frames.

Double tagged frames are simply forwarded treating them as if they were single tagged frames. At the egress of the Ethernet port, such frames are forwarded only if the S-VLAN ID of that frame is a member of the Port VLAN Membership.

#### *PVID (Port VLAN ID)*

This parameter sets the frame VLAN ID when the ingress frame is untagged (e.g. when in 'port VLAN membership' the 'egress action' is set to 'untagged and forward') or priority-tagged (VLAN=0). The value can be between 1 and 4094. The default is 1.

---

**Note:** The Port VLAN Membership must contain the PVID. If the Port VLAN Membership does not contain the PVID, untagged or priority-tagged frames will be discarded.

---

## COPY VLAN MEMBERSHIP

### *To Port*

This parameter when set copies the port VLAN Membership settings to the other ports.

## PORT VLAN MEMBERSHIP

### *VLAN ID*

This parameter sets the VLAN ID of the port for a maximum 64 active VLANs. The value can be between 1 and 4094. The default is 1.

### *VLAN Description*

This parameter is a freeform field used to identify the VLAN. It can be up to a maximum of 32 characters.

### Egress Action

This parameter sets the action taken on the frame on egress from the Ethernet port. The default is Untag and forward.

Option	Function
Untag and forward	Removes the tagged information and forwards the frame. On Ingress, the VLAN tag will be added to the PVID tag.
Forward	Forwards the tagged frame as it is on egress. On Ingress, traffic is expected to include the VLAN tag with a member VLAN ID, otherwise the packet will be dropped.

### Controls

The Add button adds the selected entry.

The Delete button deletes the selected entry.

# IP

## IP > IP Summary > Bridge / Gateway Router Modes

This page displays the current settings for the Networking IP Settings for an Ethernet Operating Mode of 'Bridge' or 'Gateway Router'.

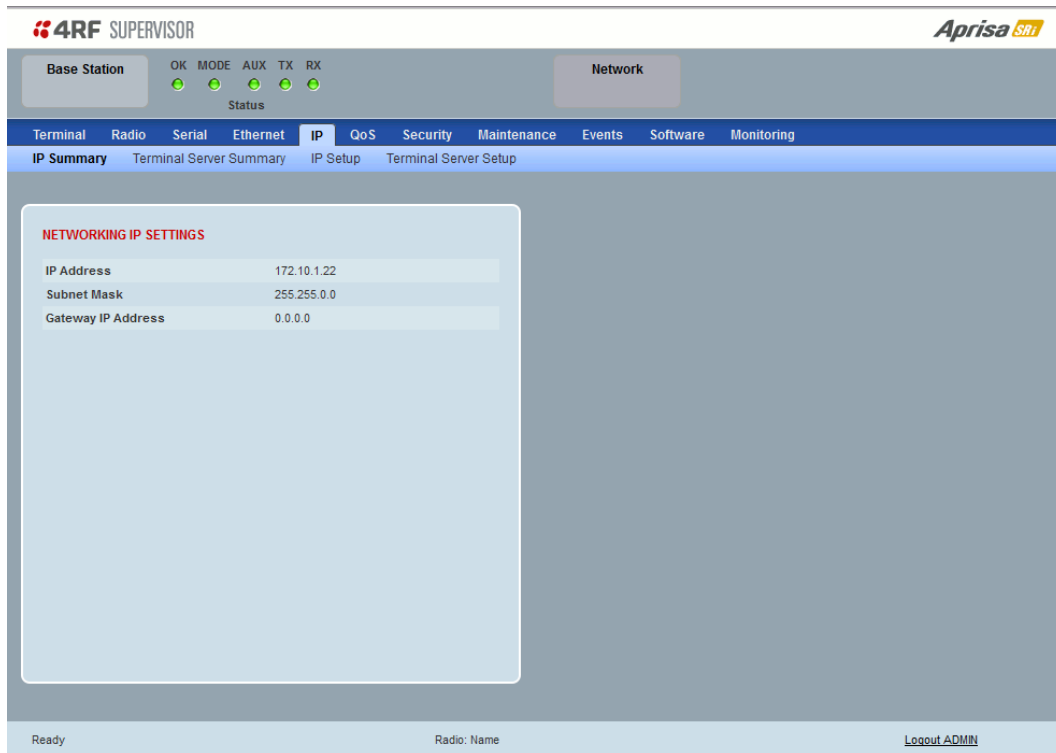

See 'IP > IP Setup > Bridge / Gateway Router Modes' on page 129 for configuration options.



## IP > IP Summary > Router Mode

This page displays the current settings for the Networking IP Settings for an Ethernet Operating Mode of 'Router'.

The screenshot displays the 4RF Supervisor interface for the IP Summary page in Router Mode. At the top, there are status indicators for Base Station (OK, MODE, AUX, TX, RX) and Network. The navigation menu includes Terminal, Radio, Serial, Ethernet, IP, QoS, Security, Maintenance, Events, Software, and Monitoring. The IP Summary page shows the following configuration:

PORT 1 IP ADDRESS		RF IP ADDRESS	
IP Address	172.10.1.22	IP Address	0.0.0.0
subnet Mask	255.255.0.0	Subnet Mask	0.0.0.0
PORT 2 IP ADDRESS		DEFAULT GATEWAY	
IP Address	0.0.0.0	IP Address	0.0.0.0
subnet Mask	255.255.0.0		

At the bottom of the page, it shows 'Ready', 'Radio: Base Station', and a 'Logout ADMIN' link.

See 'IP > IP Setup > Router Mode' on page 130 for configuration options.

## IP > IP Terminal Server Summary

This page provides the setup for the IP Settings for an Ethernet Operating Mode of ‘Bridge’ or ‘Gateway Router’.



### TERMINAL SERVER SUMMARY

IP Terminal Server converts local incoming IP packets to a local physical serial port and to OTA serial packets.

This function is typically used on a base / master station to convert traffic to serial OTA for transmission to all remote radios

See ‘IP > IP Terminal Server Setup’ for configuration options.

## IP &gt; IP Setup &gt; Bridge / Gateway Router Modes

This page provides the setup for the IP Settings for an Ethernet Operating Mode of 'Bridge' or 'Gateway Router'.

The screenshot displays the '4RF SUPERVISOR' web interface. At the top, there are status indicators for 'Base Station' (OK, MODE, AUX, TX, RX) and a 'Network' tab. The main navigation menu includes 'Terminal', 'Radio', 'Serial', 'Ethernet', 'IP', 'QoS', 'Security', 'Maintenance', 'Events', 'Software', and 'Monitoring'. Below this, a sub-menu shows 'IP Summary', 'Terminal Server Summary', 'IP Setup', and 'Terminal Server Setup'. The central content area is titled 'NETWORKING IP SETTINGS' and contains the following configuration fields:

IP Address	172.10.1.22
Subnet Mask	255.255.0.0
Gateway IP Address	0.0.0.0

Below the fields are 'Save' and 'Cancel' buttons. The bottom status bar shows 'Ready', 'Radio: Name', and a 'Logout ADMIN' link.

## NETWORKING IP SETTINGS

### *IP Address*

Set the static IP Address of the radio (Management and Ethernet ports) assigned by your site network administrator using the standard format xxx.xxx.xxx.xxx. This IP address is used both in Bridge mode and in Router mode. The default IP address is in the range 169.254.50.10.

### *Subnet Mask*

Set the Subnet Mask of the radio (Management and Ethernet ports) using the standard format xxx.xxx.xxx.xxx. The default subnet mask is 255.255.0.0 (/16).

### *Gateway*

Set the Gateway address of the radio, if required, using the standard format xxx.xxx.xxx.

A default gateway is the node on the network that traffic is directed to when an IP address does not match any other routes in the routing table. It can be the IP address of the router or PC connected to the base station. The default gateway commonly connects the internal radio network and the outside network. The default Gateway is 0.0.0.0.

## IP > IP Setup > Router Mode

This page provides the setup for the IP Settings for and Ethernet Operating Mode of 'Router'.

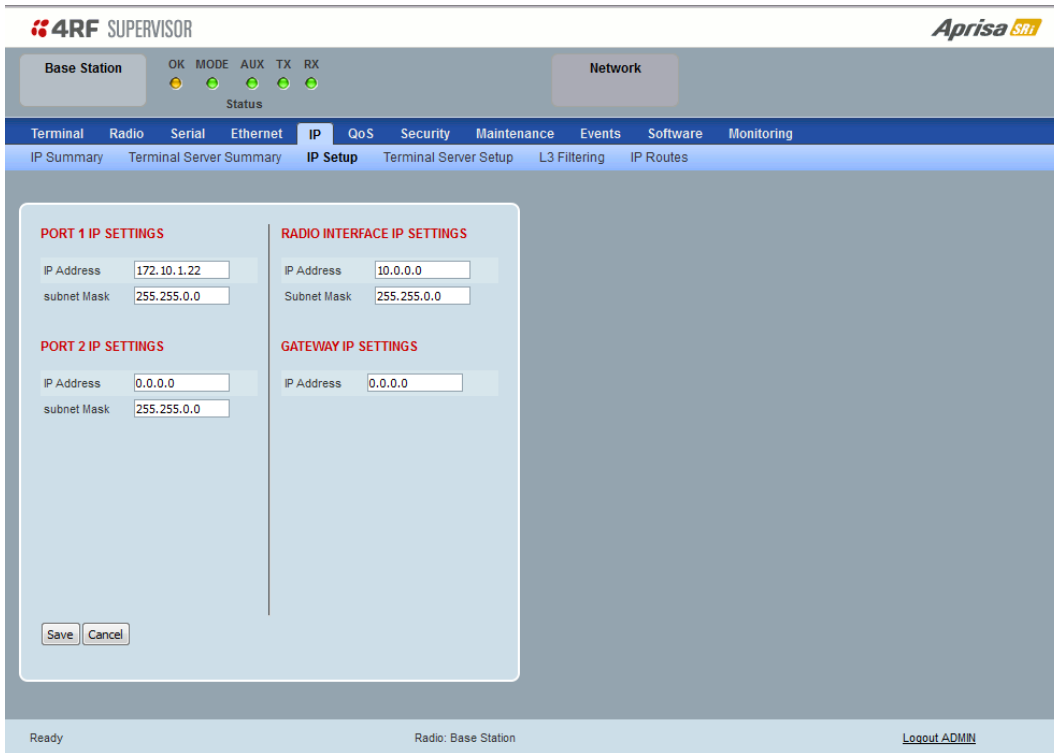

The screenshot shows the 4RF Supervisor web interface. At the top, there's a status bar with 'Base Station' and 'Network' sections. Below that is a navigation menu with 'IP' selected. The main content area is titled 'IP Setup' and contains four configuration sections:

- PORT 1 IP SETTINGS:** IP Address: 172.10.1.22, subnet Mask: 255.255.0.0
- PORT 2 IP SETTINGS:** IP Address: 0.0.0.0, subnet Mask: 255.255.0.0
- RADIO INTERFACE IP SETTINGS:** IP Address: 10.0.0.0, Subnet Mask: 255.255.0.0
- GATEWAY IP SETTINGS:** IP Address: 0.0.0.0

At the bottom left of the configuration area are 'Save' and 'Cancel' buttons. The footer of the interface shows 'Ready', 'Radio: Base Station', and a 'Logout ADMIN' link.

### PORT SETTINGS

#### *IP Address*

Set the static IP Address of the radio Ethernet port (n) assigned by your site network administrator using the standard format xxx.xxx.xxx.xxx. This IP address is used for this Ethernet port Router mode.

#### *Subnet Mask*

Set the Subnet Mask of the of the radio Ethernet port (n) using the standard format xxx.xxx.xxx.xxx. The default subnet mask is 255.255.0.0 (/16).

#### *Gateway*

Set the Gateway address of the radio Ethernet port (n), if required, using the standard format xxx.xxx.xxx.

A default gateway is the node on the network that traffic is directed to when an IP address does not match any other routes in the routing table. It can be the IP address of the router or PC connected to the base station. The default gateway commonly connects the internal radio network and the outside network. The default Gateway is 0.0.0.0.

## RADIO INTERFACE IP SETTINGS

The RF interface IP address is the address that traffic is routed to for transport over the radio link. This IP address is only used when Router Mode is selected i.e. not used in Bridge Mode.

### *Radio Interface IP Address*

Set the IP Address of the RF interface using the standard format xxx.xxx.xxx.xxx. The default IP address is in the range 10.0.0.0.

### *Radio Interface Subnet Mask*

Set the Subnet Mask of the RF interface using the standard format xxx.xxx.xxx.xxx. The default subnet mask is 255.255.0.0 (/16).

---

**Note 1:** If the base station RF interface IP address is a network IP address, and if the remote radio is also using a network IP address within the same subnet or different subnet, then the base radio will assign an automatic RF interface IP address from its own subnet.

When the base radio has a host specific RF interface IP address, then all the remotes must have a host specific RF interface IP address from the same subnet.

**Note 2:** When a remote radio is configured for Router Mode and the base radio is changed from Bridge Mode to Router Mode and the RF interface IP address is set to AUTO IP configuration (at least the last octet of the RF interface IP address is zero), it is mandatory to configure the network topology by using the 'Decommission Node' and 'Discover Nodes' (see 'Maintenance > Advanced' on page 192).

---

## IP > IP Terminal Server Setup

This page provides the setup for the IP Settings for an Ethernet Operating Mode of ‘Bridge’ or ‘Gateway Router’.

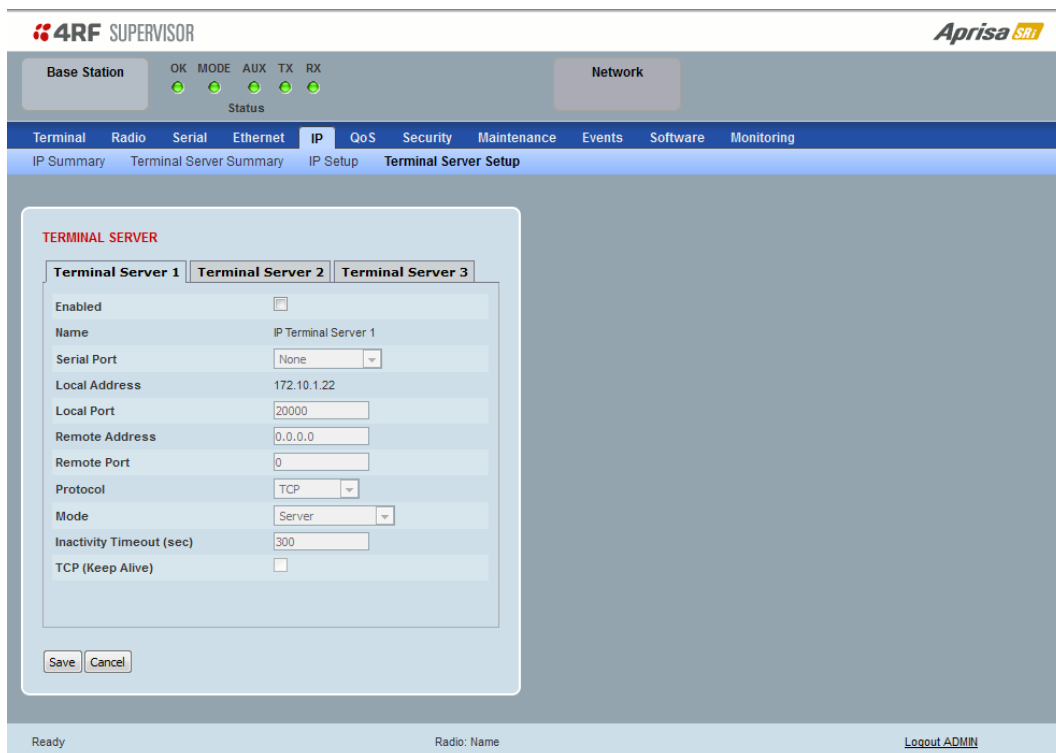

### TERMINAL SERVER

#### Enabled

This parameter enables IP terminal server.

IP Terminal Server converts local incoming IP packets to a local physical serial port and to OTA serial packets as well. This function is typically used on a base / master station to convert traffic to serial OTA for transmission to all remote radios.

#### Name

This parameter displays the IP terminal server port name.

#### Serial Port

This parameter selects the serial port to use IP terminal server.

Option	Function
Serial Port	This is the normal RS-232 serial ports provided with the RJ45 connector.
USB Serial Port	This is the optional RS-232 / RS-485 serial port provided with the USB host port connector with a USB to RS-232 / RS-485 RJ45 converter cable (see ‘USB Serial Ports’ on page 261).

### Local Address

This parameter displays the IP address of this radio.

### Local Port

This parameter sets the TCP or UDP port number of the local serial port.

The valid port number range is greater than or equal to 1024 and less than or equal to 49151 but with exclusions of 0, 5445, 6445, 9930 or 9931. The default setting is 20000.

### Remote Address

This parameter sets the IP address of the server connected to the radio Ethernet port.

### Remote Port

This parameter sets the TCP or UDP port number of the server connected to the radio Ethernet port. The default setting is 0.

### Protocol

This parameter sets the L4 TCP/IP or UDP/IP protocol used for terminal server operation. The default setting is TCP.

### Mode

This parameter defines the mode of operation of the terminal server connection. The default setting is Client and Server.

Option	Function
Client	The radio will attempt to establish a TCP connection with the specified remote unit. Generally, this setting is for the base station with an Ethernet connection to the SCADA master.
Server	The radio will listen for a TCP connection on the specified local port. Generally, this setting is for the remote station with a serial connection to the RTU. Data received from any client shall be forwarded to the associated serial port while data received from that serial port shall be forwarded to every client with an open TCP connection. If no existing TCP connections exist, all data received from the associated serial port shall be discarded.
Client and Server	The radio will listen for a TCP connection on the specified local port and if necessary, establish a TCP connection with the specified remote unit. Generally, this setting is used for the remote station but it should be used carefully as two connections might be established with the base station. Data received from any client shall be forwarded to the associated serial port while data received from that serial port shall be forwarded to every client with an open TCP connection.

### *Inactivity Timeout (seconds)*

This specifies the duration (in seconds) to automatically terminate the connection with the remote TCP server if no data has been received from either the remote TCP server or its associated serial port for the duration of the configured inactivity time.

### *TCP Keep Alive*

A TCP keep alive is a message sent by one device to another to check that the link between the two is operating, or to prevent the link from being broken.

If the TCP keep alive is enabled, the radio will be notified if the TCP connection fails.

If the TCP keep alive is disabled, the radio relies on the Inactivity Timeout to detect a TCP connection failure. The default setting is disabled.

---

**Note:** An active TCP keep alive will generate a small amount of extra network traffic.

---



## IP > L3 Filtering

This page is only available if the Ethernet traffic option has been licensed (see ‘Maintenance > Licence’ on page 191) and Router Mode selected. The filter operates in either Bridge Mode or Router Mode (see ‘Terminal > Operating Mode’ on page 86).

Select	Priority	Action	Source IP Address	Source Wildcard Mask	Source Port Range	Destination IP Address	Destination Wildcard Mask	Destination Port Range	Protocol
<input type="radio"/>	1	Process	10.0.0.1	0.0.0.0	1-65535	0.0.0.0	0.0.0.0	1-65535	Any
<input type="radio"/>	2	Discard	10.0.0.2	0.0.0.0	1-65535	0.0.0.0	0.0.0.0	1-65535	TCP
<input type="radio"/>	3	Discard	10.0.0.3	0.0.0.255	1000-2000	0.0.0.0	0.0.0.0	161	Any
<input type="radio"/>	4	Process	10.0.0.3	0.0.0.0	1-65535	0.0.0.0	0.0.0.0	1-65535	ICMP

### NETWORKING L3 FILTER SETTINGS

L3 Filtering provides the ability to evaluate traffic and take specific action based on the filter criteria.

This filtering can also be used for L4 TCP / UDP port filtering which in most cases relates to specific applications as per IANA official and unofficial well-known ports.

Entering a \* into any field will automatically enter the wildcard values when the data is saved.

#### Priority

This parameter shows the priority order in which the filters are processed.

#### Action

This parameter defines the action taken on the packet when it meets the filter criteria.

Option	Function
Process	Processes the packet if it meets the filter criteria
Discard	Discards the packet if it meets the filter criteria

#### Source IP Address

If the source IP address is set to 0.0.0.0, any source IP address will meet the filter criteria.

### *Source Wildcard Mask*

This parameter defines the mask applied to the source IP address. 0 means that it must be a match.

If the source wildcard mask is set to 0.0.0.0, the complete source IP address will be evaluated for the filter criteria.

If the source wildcard mask is set to 0.0.255.255, the first 2 octets of the source IP address will be evaluated for the filter criteria.

If the source wildcard mask is set to 255.255.255.255, none of the source IP address will be evaluated for the filter criteria.

---

Note: The source wildcard mask operation is the inverse of subnet mask operation

---

### *Source Port Range*

This parameter defines the port or port range for the source. To specify a range, insert a dash between the ports e.g. 1000-2000. If the source port range is set to 1-65535, traffic from any source port will meet the filter criteria.

### *Destination IP Address*

This parameter defines the destination IP address of the filter. If the destination IP address is set to 0.0.0.0, any destination IP address will meet the filter criteria.

### *Destination Wildcard Mask*

This parameter defines the mask applied to the destination IP address. 0 means that it must be a match.

If the destination wildcard mask is set to 0.0.0.0, the complete destination IP address will be evaluated for the filter criteria.

If the destination wildcard mask is set to 0.0.255.255, the first 2 octets of the destination IP address will be evaluated for the filter criteria.

If the destination wildcard mask is set to 255.255.255.255, none of the destination IP address will be evaluated for the filter criteria.

---

Note: The destination wildcard mask operation is the inverse of subnet mask operation

---

### *Destination Port Range*

This parameter defines the port or port range for the destination. To specify a range, insert a dash between the ports e.g. 1000-2000. If the destination port range is set to 1-65535, traffic to any destination port will meet the filter criteria.

### *Protocol*

This parameter defines the Ethernet packet type that will meet the filter criteria.

## Controls

The Delete button deletes the selected entry.

The Move Up button moves the selected entry above the entry above it increasing its process priority.

The Move Down button moves the selected entry below the entry above it reducing its process priority.

## IP > IP Routes

This page is only available if the Ethernet traffic option has been licensed (see 'Maintenance > Licence' on page 191) and Router Mode selected. It is not valid for Bridge Mode (see 'Terminal > Operating Mode' on page 86).

**4RF SUPERVISOR** **Aprisa SRI**

Base Station OK MODE AUX TX RX Network

Status

Terminal Radio Serial Ethernet **IP** QoS Security Maintenance Events Software Monitoring

IP Summary Terminal Server Summary IP Setup Terminal Server Setup L3 Filtering **IP Routes**

**NETWORKING IP STATIC ROUTE SETTINGS**

Select	Route Index	Destination Address	Destination Mask	Gateway Address	Gateway Interface
<input type="radio"/>	1	192.10.1.0	255.255.255.0	172.10.1.10	Ethernet Ports
<input type="radio"/>	2	186.15.2.0	255.255.255.0	10.10.0.11	Radio Path

Save Cancel Add Delete Delete All Prev Next

NB: Router Mode on this unit has not been enabled.

Ready Radio: Name Logout ADMIN

### NETWORKING IP STATIC ROUTE SETTINGS

Static routing provides the ability to evaluate traffic to determine if packets are forwarded over the radio link or discarded based on the route criteria.

#### *Route Index*

This parameter shows the route index.

#### *Destination Address*

This parameter defines the destination IP address of the route criteria.

#### *Destination Mask*

This parameter defines the subnet mask applied to the Destination IP Address. 255 means that it must be a match.

If the destination subnet mask is set to 255.255.255.255, all octets of the Destination IP Address will be evaluated for the route criteria.

If the destination subnet mask is set to 255.255. 0.0, the first 2 octets of the Destination IP Address will be evaluated for the route criteria.

### *Gateway Address*

This parameter sets the gateway address where packets will be forwarded to.

- If the gateway interface is set to Ethernet Ports, the gateway address is the IP address of the device connected to the Ethernet port.
- If the gateway interface is set to Radio Path, the gateway address is the IP address of the remote radio.

### *Gateway Interface*

This parameter sets the destination interface.

Option	Function
Ethernet Ports	Packets are forwarded to the Ethernet interface port.
Radio Path	Packets are forwarded to the RF Interface radio path.

## QoS

### QoS > Summary

This page provides a summary of the QoS Settings.

The screenshot shows the 4RF SUPERVISOR web interface. At the top, there is a navigation bar with the following tabs: Terminal, Radio, Serial, Ethernet, IP, **QoS**, Security, Maintenance, Events, Software, and Monitoring. Below the navigation bar, there is a sub-menu with 'Summary', 'Traffic Priority', and 'Traffic Classification'. The main content area is titled 'TRAFFIC PRIORITY' and contains the following information:

**Default Management Data Priority** Medium

**SERIAL PRIORITY**

Port	Description	Priority
1	Serial Port	Very High
2	USB Serial Port	Very High

**ETHERNET PRIORITY**

Port	Description	Priority	Default Priority
1	Ethernet Port	Low	N/A
2	Ethernet Port	Low	N/A

At the bottom of the interface, there is a status bar with 'Ready', 'Radio: Name', and a 'Logout ADMIN!' link.

See 'QoS > Traffic Priority' and 'QoS > Traffic Classification' for configuration options.

## QoS &gt; Traffic Priority

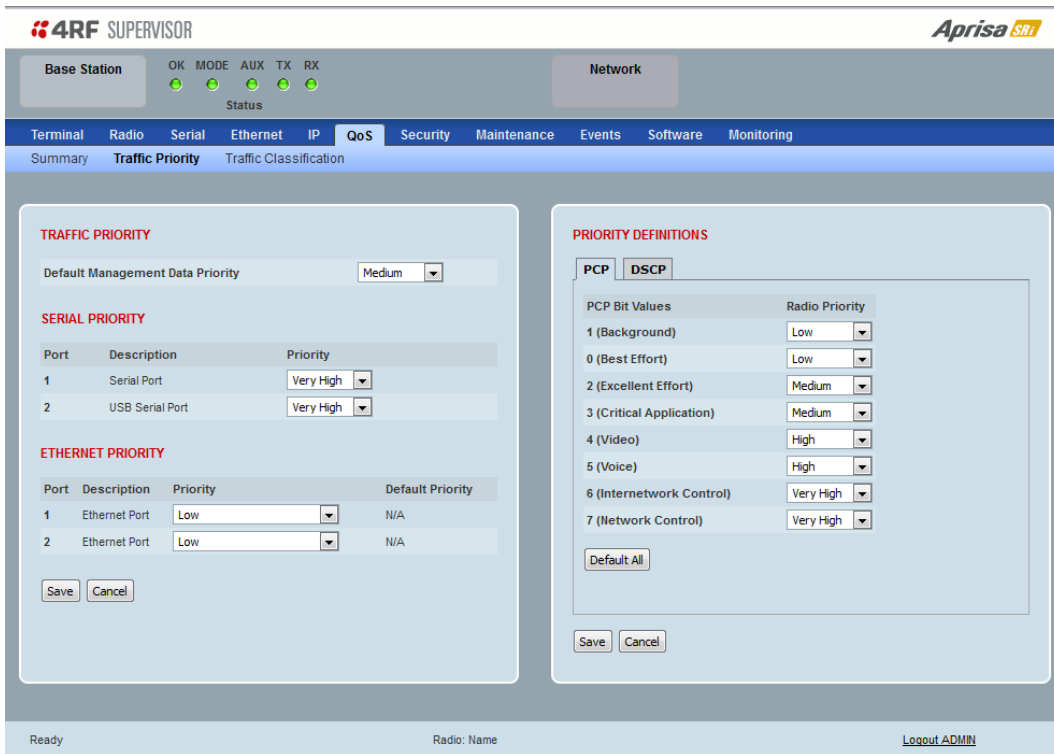

**TRAFFIC PRIORITY**

Default Management Data Priority:

**SERIAL PRIORITY**

Port	Description	Priority
1	Serial Port	Very High
2	USB Serial Port	Very High

**ETHERNET PRIORITY**

Port	Description	Priority	Default Priority
1	Ethernet Port	Low	N/A
2	Ethernet Port	Low	N/A

**PRIORITY DEFINITIONS**

PCP DSCP

PCP Bit Values	Radio Priority
1 (Background)	Low
0 (Best Effort)	Low
2 (Excellent Effort)	Medium
3 (Critical Application)	Medium
4 (Video)	High
5 (Voice)	High
6 (Internetwork Control)	Very High
7 (Network Control)	Very High

Ready Radio: Name Logout ADMIN

## TRAFFIC PRIORITY

*Default Management Data Priority*

The Default Management Data Priority controls the priority of the Ethernet management traffic relative to Ethernet customer traffic. It can be set to Very High, High, Medium and Low. The default setting is Medium.

This priority is also used for traffic if the remote serial port is not available for the radio hardware data port option e.g. if the base station is 2E2S and a remote radio is 4E0S.

## SERIAL PRIORITY

This parameter controls the per port priority of the serial customer traffic relative to the Ethernet customer traffic. If equal priority is required to Ethernet traffic, this setting must be the same as the Ethernet Data Priority setting.

The serial data priority can be set to Very High, High, Medium and Low. The default setting is Low.

A queuing system is used to prioritize traffic from the serial and Ethernet interfaces for over the air transmission. A weighting may be given to each data type and this is used to schedule the next transmission over the air e.g. if there are pending data packets in multiple buffers but serial data has a higher weighting it will be transmitted first. The serial buffer is 20 serial packets (1 packet can be up to 512 bytes).

There are four priority queues in the Aprisa SRi: Very High, High, Medium and Low. Data is added to one of these queues depending on the priority setting. Data leaves the queues from highest priority to lowest: the Very High queue is emptied first, followed by High then Medium and finally Low.

## ETHERNET PRIORITY

This parameter controls the per port priority of the Ethernet customer traffic relative to the serial customer traffic. If equal priority is required to serial traffic, this setting must be the same as the Serial Data Priority setting.

The Ethernet Priority enables users to set the priority of Ethernet port ingress frames. The priority for each port can be:

1. From PCP priority bits (VLAN priority) in VLAN tagged frames or priority tag (VLAN 0) frames
2. From DSCP priority bits in an IP packet (DSCP in IPv4 TOS field)
3. All frames are set to 'very high' priority
4. All frames are set to 'high' priority
5. All frames are set to 'medium' priority
6. All frames are set to 'low' priority

The default setting is Low.

A queuing system is used to prioritize customer traffic from the serial and Ethernet interfaces for over the air transmission. A weighting may be given to each data type and this is used to schedule the next transmission over the air e.g. if there are pending data packets in multiple buffers but serial data has a higher weighting it will be transmitted first. The Ethernet buffer is 10 Ethernet packets (1 packet can be up to Ethernet MTU, 1536 bytes).

There are four priority queues in the Aprisa SRi: Very High, High, Medium and Low. Data is added to one of these queues depending on the priority setting. Data leaves the queues from highest priority to lowest: the Very High queue is emptied first, followed by High then Medium and finally Low.

### Default Priority

When the priority of an Ethernet port uses the PCP bits (VLAN priority) values the 'Default Priority' option is enabled, allowing the priority of untagged VLAN frames to be set.

When the priority of an Ethernet port uses the DSCP priority (in IPv4 TOS field) values the 'Default Priority' option is enabled, allowing the priority of ARP frames to be set.

## PRIORITY DEFINITIONS

### PCP (Priority Code Point)

These settings provide priority translation / mapping between the external radio LAN VLAN priority network and the radio internal VLAN priority network, using the VLAN tagged PCP (Priority Code Point) priority field in the Ethernet/VLAN frame.

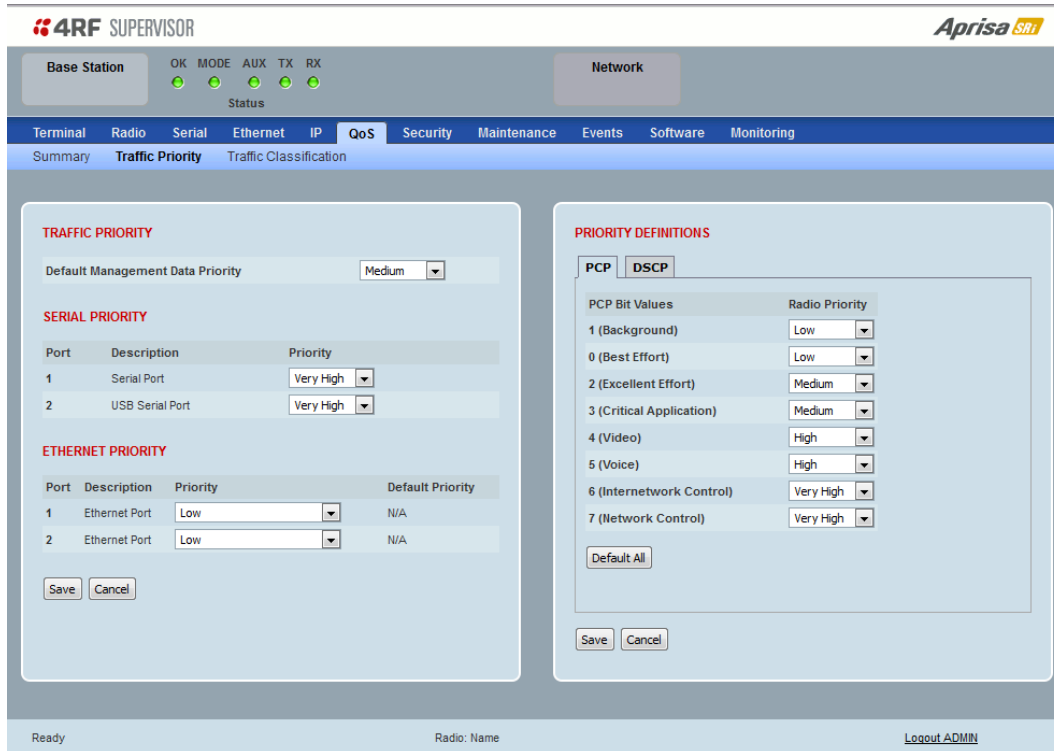

The screenshot shows the 4RF SUPERVISOR web interface. At the top, there's a status bar with 'Base Station' and 'Network' sections. Below that is a navigation menu with 'Terminal', 'Radio', 'Serial', 'Ethernet', 'IP', 'QoS', 'Security', 'Maintenance', 'Events', 'Software', and 'Monitoring'. The 'QoS' section is expanded to show 'Summary', 'Traffic Priority', and 'Traffic Classification'. The main content area is divided into two panels. The left panel, titled 'TRAFFIC PRIORITY', has a 'Default Management Data Priority' dropdown set to 'Medium'. Below it are 'SERIAL PRIORITY' and 'ETHERNET PRIORITY' tables. The right panel, titled 'PRIORITY DEFINITIONS', has tabs for 'PCP' and 'DSCP'. The 'PCP' tab is active, showing a table for mapping PCP Bit Values to Radio Priority. The table has two columns: 'PCP Bit Values' and 'Radio Priority'. The rows are: 1 (Background) - Low, 0 (Best Effort) - Low, 2 (Excellent Effort) - Medium, 3 (Critical Application) - Medium, 4 (Video) - High, 5 (Voice) - High, 6 (Internetwork Control) - Very High, and 7 (Network Control) - Very High. There are 'Save' and 'Cancel' buttons at the bottom of the table. The interface also shows other configuration sections like 'TRAFFIC PRIORITY', 'SERIAL PRIORITY', and 'ETHERNET PRIORITY'.

The IEEE 802.1Q specification defines a standards-based mechanism for providing VLAN tagging and class of service (CoS) across Ethernet networks. This is accomplished through an additional VLAN tag, which carries VLAN tag ID and frame prioritization information (PCP field), inserted within the header of a Layer 2 Ethernet frame.

Priority Code Point (PCP) is a 3-bit field that indicates the frame priority level (or CoS). The operation of the PCP field is defined within the IEEE 802.1p standard, which is an extension of 802.1Q. The standard establishes eight levels of priority, referred to as CoS values, where CoS 7 ('111' in PCP field) is the highest priority and CoS 0 ('000') is the lowest priority.

The radio in bridge mode uses the PCP value in the VLAN tag to prioritize packets and provide the appropriate QoS treatment per traffic type. The radio implements 4 priority queuing techniques that base its QoS on the VLAN priority (PCP). Based on VLAN priority bits, traffic can be put into a particular Class of Service (CoS) queue. Packets with higher CoS will always serve first for OTA transfer and on ingress/egress Ethernet ports.

The 'PCP priority definition' tab is used to map ingress VLAN packet with PCP priority to the radio internal CoS (priority). Since, in most of the cases the radio VLAN network is connected to the corporate VLAN networks, the network administrator might like to have a different VLAN priority scheme of the radio network CoS. For example, management traffic in the multi-gigabit corporate VLAN network might be prioritized with priority 7 (highest priority) and SCADA traffic with priority 5, but in the narrow bandwidth radio network, SCADA traffic will be mapped to radio very high CoS / priority (i.e. set PCP 5 = Very high) and management traffic might be mapped to radio medium CoS / priority (i.e. set PCP 7 = medium) in order to serve first the mission-critical SCADA traffic over the radio network.



This is done by mapping the external radio network VLAN priority to the internal radio CoS / priority using the 'PCP priority definition' tab. The radio support 4 queues, thus at maximum an 8 -> 4 VLAN priority / CoS mapping is done.

Default mapping of ingress packet VLAN priority to radio CoS / priority shown in the 'PCP priority definition' tab.

### DSCP (Differentiated Services Code Point)

These settings provide translation / mapping between the external radio IP priority network and the radio internal IP priority network, using the DSCP (DiffServ Code Point) priority field in the IP packet header.

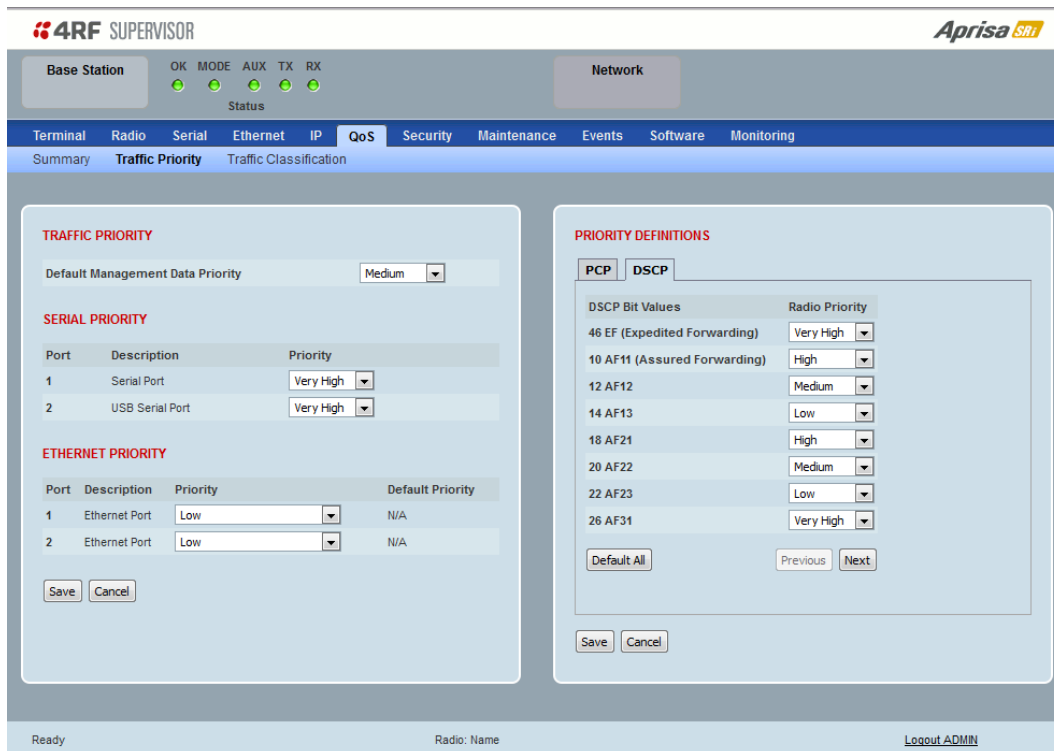

The screenshot shows the 4RF SUPERVISOR web interface for an Aprisa SRi radio. The interface is divided into several sections:

- Base Station Status:** Shows OK, MODE, AUX, TX, and RX indicators.
- Network Tab:** Selected, showing various network-related tabs like Terminal, Radio, Serial, Ethernet, IP, QoS, Security, Maintenance, Events, Software, and Monitoring.
- Traffic Priority Section:**
  - Default Management Data Priority:** Set to Medium.
  - SERIAL PRIORITY Table:**

Port	Description	Priority
1	Serial Port	Very High
2	USB Serial Port	Very High
  - ETHERNET PRIORITY Table:**

Port	Description	Priority	Default Priority
1	Ethernet Port	Low	N/A
2	Ethernet Port	Low	N/A
- PRIORITY DEFINITIONS Section:**
  - PCP / DSCP Tab:** Selected.
  - DSCP Bit Values Table:**

DSCP Bit Values	Radio Priority
46 EF (Expedited Forwarding)	Very High
10 AF11 (Assured Forwarding)	High
12 AF12	Medium
14 AF13	Low
18 AF21	High
20 AF22	Medium
22 AF23	Low
26 AF31	Very High
  - Buttons:** Default All, Previous, Next, Save, Cancel.

Differentiated Services (DiffServ) is a new model in which traffic is treated by routers with relative priorities based on the IPv4 type of services (ToS) field. DSCP (DiffServ Code Point) standard defined in RFC 2474 and RFC 2475. DiffServ increases the number of definable priority levels by reallocating bits of an IP packet for priority marking.

The DiffServ architecture defines the DiffServ (DS) field, which supersedes the ToS field in IPv4 to make per-hop behaviour (PHB) decisions about packet classification and traffic scheduling functions. The six most significant bits of the DiffServ field (in the IPv4 TOS field) is called as the DSCP. The standardized DiffServ field of the packet is marked with a value so that the packet receives a particular routing/forwarding treatment or PHB, at each router node. Using DSCP packet classification, traffic can be partitioned into multiple priority levels.

The radio in router mode uses the DSCP value in the IP header to select a PHB behaviour for the packet and provide the appropriate QoS treatment. The radio implements 4 priority queuing techniques that base its PHB on the DSCP in the IP header of a packet. Based on DSCP, traffic can be put into a particular priority / CoS (Class of Service) queue. Packets with higher CoS will always serve first for OTA transfer and on ingress / egress Ethernet ports.

The 'DSCP priority definition' tab is used to map ingress IP packet with DSCP priority to the radio internal priority / CoS. Since, in most of the cases the radio routed network is connected to the corporate routed networks, the network administrator might like to have a different routed network priority scheme of the radio network, for example management traffic in the multi-gigabit corporate routed network might be prioritized with DSCP EF (expedited forwarding) code (DSCP highest priority), and SCADA traffic with DSCP AF11 (assured forwarding) code (high priority), but in the narrow bandwidth radio network, SCADA traffic will be mapped to radio very high CoS / priority (i.e. set AF11 = Very high) and management traffic might map to radio low CoS / priority (i.e. set EF = Low) in order to serve first the mission-critical SCADA traffic over the radio network.

This is done by mapping the external radio network DSCP priority to the internal radio CoS / priority levels using the 'DSCP priority definition' tab. The radio support four queues, thus at maximum a 64 -> 4 CoS / priority mapping is done.

Default mapping of ingress packet DSCP priority to radio CoS shown in the 'DSCP priority definition' tab. The radio maps all 64 DSCP values. The user can configure most common used 21 DSCP codes and the rest are mapped by default to low CoS / priority.

## QoS > Traffic Classification

These settings provide multiple traffic classification profiles based on classification rules. Profiles for a specific traffic type, protocol or application can be assigned to a particular VLAN and CoS / priority in bridge mode or to CoS / priority in router mode to provide the appropriate QoS treatment.

For example SCADA traffic, management traffic, FTP traffic, can each have its own profile build with a set of classification rules. A profile can be build using multiple classification rules based on ports, Ethernet, IP, TCP / UDP headers fields (i.e. L1/2/3/4 header fields) such as: Ethernet port #1, VLAN ID, VLAN priority, IP DSCP Priority, MAC/IP address, TCP / UDP port fields to identify and classify the specific traffic type. When an ingress packet matches the profile L2/3/4 header fields settings, the packet is assigned to a particular VLAN and CoS / priority in bridge mode or to CoS / priority in router mode to provide the appropriate QoS treatment.

The radio supports four CoS / priority queues: very high, high, medium and low. These queues are connected to a strict priority scheduler which dispatches packets from the queues out to the egress port by always serving first the 'very high' priority queue, whenever there is a packet in this queue. When the highest priority queue empties, the scheduler will serve the next high priority queues and so on. So when SCADA traffic is assigned to a 'Very high' priority, it will always served first and send over-the-air (OTA) whenever SCADA traffic enters to the radio, giving it the highest priority over other traffic type.

These settings are different for Bridge Mode and Router Mode.

## Bridge Mode Traffic Classification Settings

The screenshot shows the 4RF SUPERVISOR web interface. At the top, there are logos for 4RF and Aprisa SRi. Below the logos, there are status indicators for Base Station (OK, MODE, AUX, TX, RX) and a Network tab. The main navigation menu includes Terminal, Radio, Serial, Ethernet, IP, QoS, Security, Maintenance, Events, Software, and Monitoring. The sub-menu includes Summary, Traffic Priority, and Traffic Classification. The Traffic Classification page displays a table with the following data:

Select	Order	Profile Name	Assigned Priority	Assigned VLAN ID	Active
<input type="radio"/>	1	Traffic Classification L2 Rule 1	Low	18	<input checked="" type="checkbox"/>
<input type="radio"/>	2	Traffic Classification L2 Rule 2	Medium	20	<input checked="" type="checkbox"/>
<input type="radio"/>	3	Traffic Classification L2 Rule 3	High	22	<input checked="" type="checkbox"/>

Below the table, there are buttons for Save, Cancel, Edit, Add, Delete, Delete All, Move Up, Move Down, Previous, and Next. At the bottom of the interface, it shows 'Ready', 'Radio: Base Station', and a 'Logout ADMIN!' link.

### TRAFFIC CLASSIFICATION

VLAN bridge mode traffic classification settings provide mapping / assigning of profiles (set by rules to match a specific traffic type) to a VLAN ID and VLAN CoS / priority. The profile which is used to match to a specific traffic type will be identified in the radio network by its associated VLAN ID and VLAN CoS / priority to provide the appropriate QoS treatment. CoS / Priority can be set to very high, high, medium, low priority.

#### *Profile name*

A free form field to enter the profile name with a maximum of 32 chars.

#### *Assigned Priority*

Traffic packets that match the applied profile rules will be assigned to the selected 'assigned priority' setting of Very High, High, Medium and Low. This field cannot be set to Don't Care.

This applies profile rule mapping to the VLAN CoS / Priority with the appropriate internal radio assigned priority setting of Very High, High, Medium and Low.

### *Assigned VLAN ID*

Traffic packets that match the applied profile rules will be assigned to the selected 'assigned VLAN ID' setting of VLAN ID in the range of 0 to 4095.

A VLAN ID of an ingress packet matching the classification rule (see 'VLAN ID' rule in next page) shall be changed to the 'assigned VLAN ID' setting, if below conditions are met:

1. The VLAN ID of Ingress packet is same as PVID of the ingress port.
2. Packet is received untagged at the port

If the VLAN ID of the tagged ingress packet is not the same as the PVID of the ingress port, then it shall not be changed and the 'assigned VLAN ID' setting is ignored i.e. ingress VLANs will pass-through unchanged.

If 'assigned VLAN ID' value is set in the 'port VLAN membership' under Ethernet > VLAN (port x tab), then this VLAN will be available for ingress and egress on the Ethernet and RF ports, otherwise this VLAN will only be available in one direction on the egress RF port.

For example, if the base station Ethernet port 1 'assigned VLAN ID' = 100 (VLAN-100) and it is also defined in the 'port VLAN membership' under Ethernet > VLAN (port 1 tab) and the remote sends a packet to the base with a VLAN of 100, this packet will be egress out to Ethernet port 1 (tagged or untagged based on the 'egress action' definition). If the VLAN-100 wasn't set in the 'port VLAN membership', then the base station will drop a packet from the remote.

This setting parameter can be 'Don't Care' (Assigned VLAN ID = 0) which means that the VLAN ID of ingress frame will never be modified.

### *Active*

Activates or deactivates the profile rule.

## Controls

The Save button saves all profiles to the radio.

The Cancel button removes all changes since the last save or first view of the page if there has not been any saves. This button will un-select all the Select radio buttons.

The Edit button will show the next screen for the selected profile where the profile can be configured. This button will be disabled unless a profile is selected.

The Add button adds a new profile,

- If no profile was selected then the new profile is added to the end of the list,
- If a profile is selected the new profile is added after that profile.

The Delete button will delete the selected profile. The button will be disabled unless a profile has been selected.

The Delete All button will delete all the profiles. A pop-up will ask if the action is correct. If the answer is yes, then all profiles are deleted in SuperVisor. The Save button must be pressed to delete all the profiles in the radio.

The Move up button will move the selected profile up one in the order of profiles

The Move Down button will move the selected profile down one in the order of profiles

The Previous button displays the previous page in the list of profiles. A pop up will be displayed if any profile has been modified and not saved, preventing the previous page being displayed.

The Next button will display the next page in the list of profiles.

To edit a traffic classification, select the profile and click on the Edit button

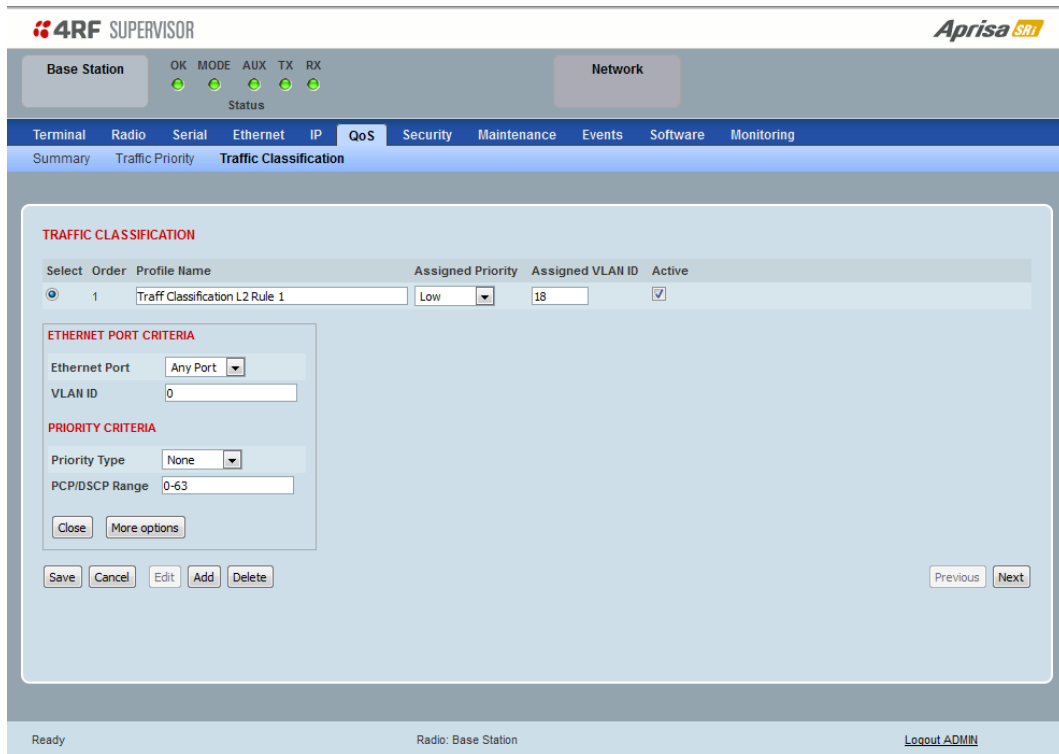

## ETHERNET PORT CRITERIA

### *Ethernet Port*

Set the layer 1 Ethernet port number or all Ethernet ports in the selected profile classification rule.

### *VLAN ID*

Sets the layer 2 packet Ethernet header VLAD ID field in the selected profile classification rule. Valid values are between 0 and 4095. This VLAN ID should be enabled in the system for using this parameter during classification.

Enable this VLAN in the network by setting the same VLAN ID value in PVID (port VLAN ID) and in the PORT VLAN MEMBERSHIP under 'VLAN PORT SETTINGS - Port 1' on page 123. If the VLAN ID is set to zero, all VLAN IDs will meet the criteria.

## PRIORITY CRITERIA

### Priority Type

Set the layer 2 Ethernet or layer 3 IP packet header priority type fields in the selected profile classification rules.

Priority Type	Description
None	Do not use any layer 2 / 3 Ethernet or IP header priority fields in the selected profile classification rules.
PCP	Use the layer 2 Ethernet header priority field of PCP (Priority Code Point) VLAN priority bits (per IEEE 802.1p/q) in the selected profile classification rules.
DSCP	Use the layer 3 IP header TOS field used as DSCP (Differentiated Services Code Point per RFC 2474 and RFC 2475) priority bit in the selected profile classification rules.

### PCP / DSCP Range

As per the 'priority type' selection, this parameter sets the PCP priority value/s or DSCP priority value/s fields in the selected profile classification rule. The value can be set to a single priority or a single range (no multiple ranges are allowed), for example, the PCP selected priority value can be 7 or a range of priority values like 4-7.

The following table shows the layer 2 packet VLAN tag header PCP priority field values

PCP Value (Decimal)	PCP Priority	Priority Level
7	Priority [7]	Highest
6	Priority [6]	
5	Priority [5]	
4	Priority [4]	
3	Priority [3]	
2	Priority [2]	
1	Priority [1]	↓
0	Priority [0]	Lowest



The following table shows the layer 3 packet IP header DSCP priority field values

DSCP Value (Decimal)	DSCP Priority
46	EF (Expedited Forwarding)
10	AF11 (Assured Forwarding)
12	AF12
14	AF13
18	AF21
20	AF22
22	AF23
26	AF31
28	AF32
30	AF33
34	AF41
36	AF42
38	AF43
0	CS0/Best Effort (BE)
8	CS1 (Class Selector )
16	CS2
24	CS3
32	CS4
40	CS5
48	CS6
56	CS7

Click on More Options if more Layer 2/3/4 (Ethernet / IP / TCP or UDP) packet header fields are required for the selected profile classification rule. This page describes all the possible fields that can be used for the classification rules in bridge mode.

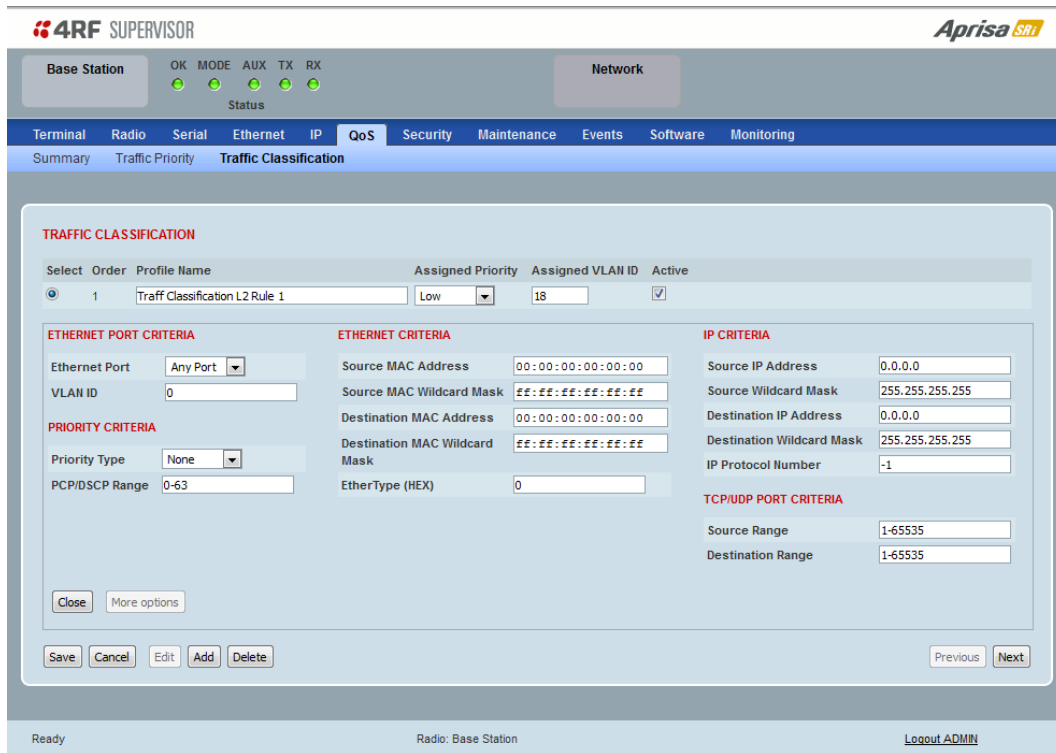

The screenshot shows the 4RF SUPERVISOR interface for configuring traffic classification rules. The main heading is 'TRAFFIC CLASSIFICATION'. Below it is a table with columns: Select, Order, Profile Name, Assigned Priority, Assigned VLAN ID, and Active. The first rule is selected, with Profile Name 'Traff Classification L2 Rule 1', Priority 'Low', and VLAN ID '18'. Below the table are several configuration sections:

- ETHERNET PORT CRITERIA:** Ethernet Port (Any Port), VLAN ID (0).
- ETHERNET CRITERIA:** Source MAC Address (00:00:00:00:00:00), Source MAC Wildcard Mask (FF:FF:FF:FF:FF:FF), Destination MAC Address (00:00:00:00:00:00), Destination MAC Wildcard Mask (FF:FF:FF:FF:FF:FF), EtherType (HEX) (0).
- IP CRITERIA:** Source IP Address (0.0.0.0), Source Wildcard Mask (255.255.255.255), Destination IP Address (0.0.0.0), Destination Wildcard Mask (255.255.255.255), IP Protocol Number (-1).
- PRIORITY CRITERIA:** Priority Type (None), PCP/DSCP Range (0-63).
- TCP/UDP PORT CRITERIA:** Source Range (1-65535), Destination Range (1-65535).

Buttons at the bottom include 'Close', 'More options', 'Save', 'Cancel', 'Edit', 'Add', 'Delete', 'Previous', and 'Next'.

## ETHERNET CRITERIA

### Source MAC Address

This parameter sets the Layer 2 Ethernet packet header Source MAC Address field in the selected profile classification rule in the format of 'hh:hh:hh:hh:hh:hh'.

### Source MAC Wildcard Mask

This parameter sets the wildcard mask of the 'Source MAC Address'. If the Source MAC Address is set to 'FF:FF:FF:FF:FF:FF', all source MAC addresses will meet the criteria.

### Destination MAC Address

This parameter sets the Layer 2 Ethernet packet header Destination MAC Address field in the selected profile classification rule in the format of 'hh:hh:hh:hh:hh:hh'.

### Destination MAC Wildcard Mask

This parameter sets the wildcard mask of the 'Destination MAC Address'. If the Destination MAC Address is set to 'FF:FF:FF:FF:FF:FF', all destination MAC addresses will meet the criteria.

### *EtherType (Hex)*

This parameter sets the Layer 2 Ethernet packet header EtherType field in the selected profile classification rule. EtherType is a 16 bit (two octets) field in an Ethernet frame. It is used to indicate which protocol is encapsulated in the payload of an Ethernet Frame.

EtherType Examples:

Protocol	EtherType Value (Hexadecimal)
IPv4	0800
ARP	0806
IPv6	86DD
VLAN	8100

## IP CRITERIA

### *Source IP Address*

This parameter sets the Layer 3 IP packet header Source IP Address field in the selected profile classification rule. This parameter is written in the standard IPv4 format of 'xxx.xxx.xxx.xxx'.

### *Source IP Wildcard Mask*

This parameter sets the wildcard mask applied to the 'Source IP Address'. This parameter is written in the standard IPv4 format of 'xxx.xxx.xxx.xxx'.

0 means that it must be a match. If the wildcard mask is set to 0.0.0.0, the complete Source IP Address will be evaluated for the classification rule.

If the wildcard mask is set to 0.0.255.255, the first 2 octets of the Source IP Address will be evaluated for the classification rule.

If the wildcard mask is set to 255.255.255.255, none of the Source IP Address will be evaluated for the classification rule.

---

Note: The wildcard mask operation is the inverse of subnet mask operation

---

### *Destination IP Address*

This parameter sets the Layer 3 IP packet header Destination IP Address field in the selected profile classification rule. This parameter is written in the standard IPv4 format of 'xxx.xxx.xxx.xxx'.

### *Destination IP Wildcard Mask*

This parameter sets the wildcard mask applied to the 'Destination IP Address'. This parameter is written in the standard IPv4 format of 'xxx.xxx.xxx.xxx'.

0 means that it must be a match. If the wildcard mask is set to 0.0.0.0, the complete Destination IP Address will be evaluated for the classification rule.

If the wildcard mask is set to 0.0.255.255, the first 2 octets of the Destination IP Address will be evaluated for the classification rule.

If the wildcard mask is set to 255.255.255.255, none of the Destination IP Address will be evaluated for the classification rule.

---

Note: The wildcard mask operation is the inverse of subnet mask operation

---

### *IP Protocol Number*

This parameter sets the Layer 3 IP packet header 'Protocol' field in the selected profile classification rule. This field defines the protocol used in the data portion of the IP datagram.

Protocol number Examples:

Protocol	Protocol value (decimal)
ICMP	1
TCP	6
UDP	17

### TCP / UDP PORT CRITERIA

#### *Source Range*

This parameter sets the Layer 4 TCP / UDP packet header Source Port or Source Port range field in the selected profile classification rule. To specify a range, insert a dash between the ports e.g. 1000-2000. If the source port range is set to 1-65535, traffic from any source port will meet the criteria.

#### *Destination Range*

This parameter sets the Layer 4 TCP / UDP packet header Destination Port or Destination Port range field in the selected profile classification rules. To specify a range, insert a dash between the ports e.g. 1000-2000. If the source port range is set to 1-65535, traffic from any source port will meet the criteria.

Examples for TCP / UDP Port Numbers:

Protocol	TCP / UDP Port # (decimal)
Modbus	502
IEC 60870-5-104	2,404
DNP 3	20,000
SNMP	161
SNMP TRAP	162

## Router Mode Traffic Classification Settings

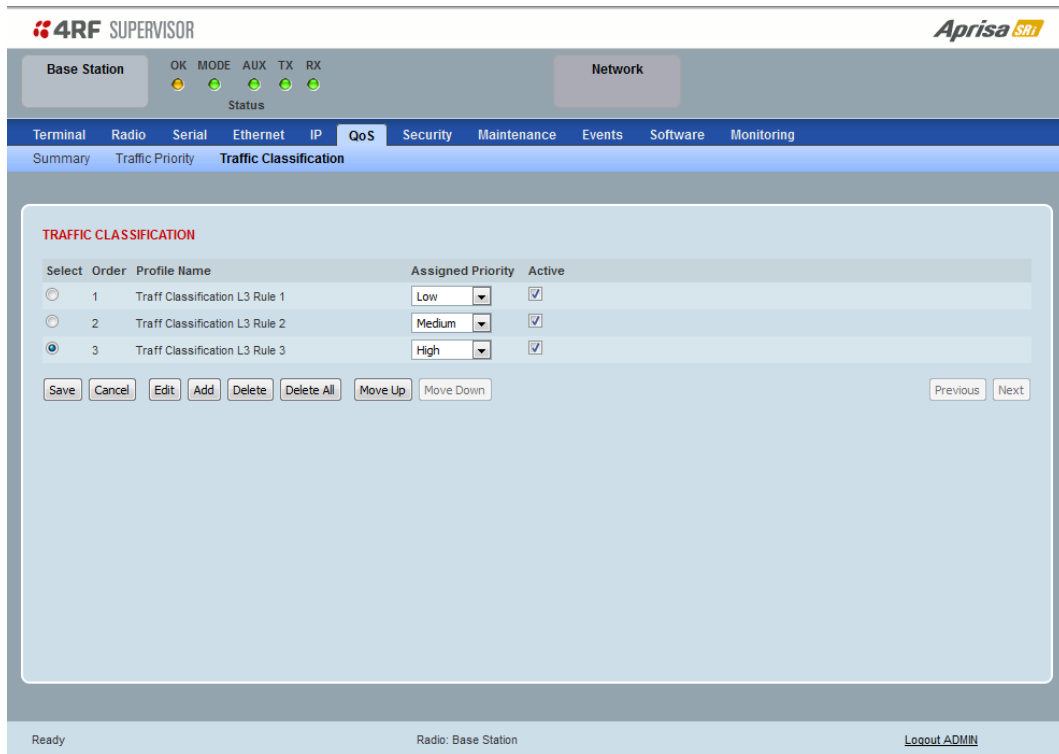

### TRAFFIC CLASSIFICATION

Router Mode traffic classification settings provide mapping / assigning of profiles (set by rules to match a specific traffic type) to a CoS / priority. The profile which is used to match to a specific traffic type will be identified in the radio network by its associated CoS / priority to provide the appropriate QoS treatment. CoS / Priority can be set to very high, high, medium, low priority.

#### Profile name

A free form field to enter the profile name with a maximum of 32 chars.

#### Assigned Priority

Traffic packets that match the applied profile rules will be assigned to the selected 'assigned priority' setting of Very High, High, Medium and Low. This field cannot be set to Don't Care.

#### Active

Activated or deactivate the profile rule.

## Controls

The Save button saves all profiles to the radio.

The Cancel button removes all changes since the last save or first view of the page if there has not been any saves. This button will un-select all the Select radio buttons.

The Edit button will show the next screen for the selected profile where the profile can be configured. This button will be disabled unless a profile is selected.

The Add button adds a new profile,

- If no profile was selected then the new profile is added to the end of the list,
- If a profile is selected the new profile is added after that profile.

The Delete button will delete the selected profile. The button will be disabled unless a profile has been selected.

The Delete All button will delete all the profiles. A pop-up will ask if the action is correct. If the answer is yes, then all profiles are deleted in SuperVisor. The Save button must be pressed to delete all the profiles in the radio.

The Move up button will move the selected profile up one in the order of profiles

The Move Down button will move the selected profile down one in the order of profiles

The Previous button displays the previous page in the list of profiles. A pop up will be displayed if any profile has been modified and not saved, preventing the previous page being displayed.

The Next button will display the next page in the list of profiles.

To edit a traffic classification, select the profile and click on the Edit button

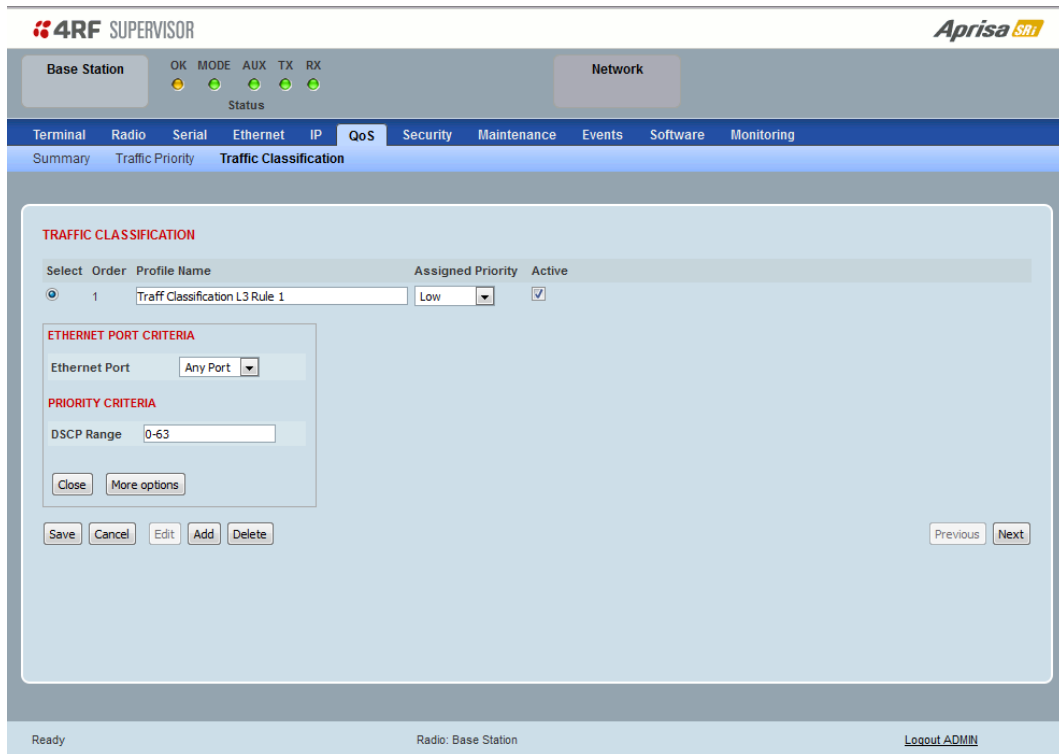

## ETHERNET PORT CRITERIA

### *Ethernet Port*

Set the layer 1 Ethernet port number or all Ethernet ports in the selected profile classification rules.

## PRIORITY CRITERIA

### *DSCP Range*

Sets the DSCP priority value/s field in the selected profile classification rule. The value can be set to a single priority or a single range (no multiple range are allowed), for example, priority value can be 46 (EF) or a range of priority values like 10-14.

The following table shows the layer 3 packet IP header DSCP priority field values

DSCP Value (Decimal)	DSCP Priority
46	EF (Expedited Forwarding)
10	AF11 (Assured Forwarding)
12	AF12
14	AF13
18	AF21
20	AF22
22	AF23
26	AF31
28	AF32
30	AF33
34	AF41
36	AF42
38	AF43
0	CS0/Best Effort (BE)
8	CS1 (Class Selector )
16	CS2
24	CS3
32	CS4
40	CS5
48	CS6
56	CS7



Click on More Options if more Layer 3/4 packet header fields are required for the selected profile classification rule. This page describes all the possible fields that can be used for the classification rules in router mode.

## IP CRITERIA

### Source IP Address

This parameter sets the Layer 3 packet IP header Source IP Address field in the selected profile classification rules. This parameter is written in the standard IPv4 format of 'xxx.xxx.xxx.xxx'.

### Source IP Wildcard Mask

This parameter sets the wildcard mask applied to the 'Source IP Address'. This parameter is written in the standard IPv4 format of 'xxx.xxx.xxx.xxx'.

0 means that it must be a match. If the wildcard mask is set to 0.0.0.0, the complete Source IP Address will be evaluated for the classification rules.

If the wildcard mask is set to 0.0.255.255, the first 2 octets of the Source IP Address will be evaluated for the classification rules.

If the wildcard mask is set to 255.255.255.255, none of the Source IP Address will be evaluated for the classification rules.

---

Note: The wildcard mask operation is the inverse of subnet mask operation

---

### Destination IP Address

This parameter sets the Layer 3 packet IP header Destination IP Address field in the selected profile classification rules. This parameter is written in the standard IPv4 format of 'xxx.xxx.xxx.xxx'.

### *Destination IP Wildcard Mask*

This parameter sets the wildcard mask applied to the 'Destination IP Address'. This parameter is written in the standard IPv4 format of 'xxx.xxx.xxx.xxx'.

0 means that it must be a match. If the wildcard mask is set to 0.0.0.0, the complete Destination IP Address will be evaluated for the classification rules.

If the wildcard mask is set to 0.0.255.255, the first 2 octets of the Destination IP Address will be evaluated for the classification rules.

If the wildcard mask is set to 255.255.255.255, none of the Destination IP Address will be evaluated for the classification rules.

---

Note: The wildcard mask operation is the inverse of subnet mask operation

---

### *Protocol Number*

This parameter sets the Layer 3 IP packet header 'Protocol' field in the selected profile classification rule. This field defines the protocol used in the data portion of the IP datagram.

Protocol number Examples:

Protocol	Protocol value (decimal)
ICMP	1
TCP	6
UDP	17

### TCP / UDP Port Criteria

#### *Source Range*

This parameter sets the Layer 4 TCP / UDP packet header Source Port or Source Port range field in the selected profile classification rule. To specify a range, insert a dash between the ports e.g. 1000-2000. If the source port range is set to 1-65535, traffic from any source port will meet the criteria.

#### *Destination Range*

This parameter sets the Layer 4 TCP / UDP packet header Destination Port or Destination Port range field in the selected profile classification rule. To specify a range, insert a dash between the ports e.g. 1000-2000. If the source port range is set to 1-65535, traffic from any source port will meet the criteria.

Examples for TCP / UDP Port Numbers:

Protocol	TCP / UDP Port # (decimal)
Modbus	502
IEC 60870-5-104	2,404
DNP 3	20,000
SNMP	161
SNMP TRAP	162

# Security

## Security > Summary

This page displays the current settings for the Security parameters.

**4RF SUPERVISOR** **Aprisa SRi**

Base Station: OK MODE AUX TX RX Status

Network

Terminal Radio Serial Ethernet IP QoS **Security** Maintenance Events Software Monitoring

Summary Setup Users SNMP RADIUS Manager Distribution

**CURRENT PAYLOAD SECURITY SETTINGS**

Security Profile Name	Migrated Key
Security Scheme	Disabled
Payload Encryption Key Type	Raw Hexadecimal (AES-128)

**PREVIOUS PAYLOAD SECURITY SETTINGS**

Security Profile Name	Inactive Payload Security
Security Scheme	Disabled
Payload Encryption Key Type	Passphrase

**PREDEFINED PAYLOAD SECURITY PROFILE SETTINGS**

Security Profile Name	Payload Security v1
Security Scheme	Disabled
Payload Encryption Key Type	Passphrase (AES-128)

**PAYLOAD KEY ENCRYPTION KEY SETTINGS**

Key Encryption Key Type	Passphrase (AES-256)
-------------------------	----------------------

**PROTOCOL SECURITY SETTINGS**

Telnet	Enabled
ICMP	Enabled
HTTPS	Disabled
SNMP Protocol	All Versions
SNMP Proxy Support	Disabled

**SECURITY LEVEL SETTINGS**

Security Level	Standard
----------------	----------

Ready Radio: Name [Logout ADMIN](#)

See 'Security > Setup' and 'Security > Manager' for configuration options.

Security > Setup

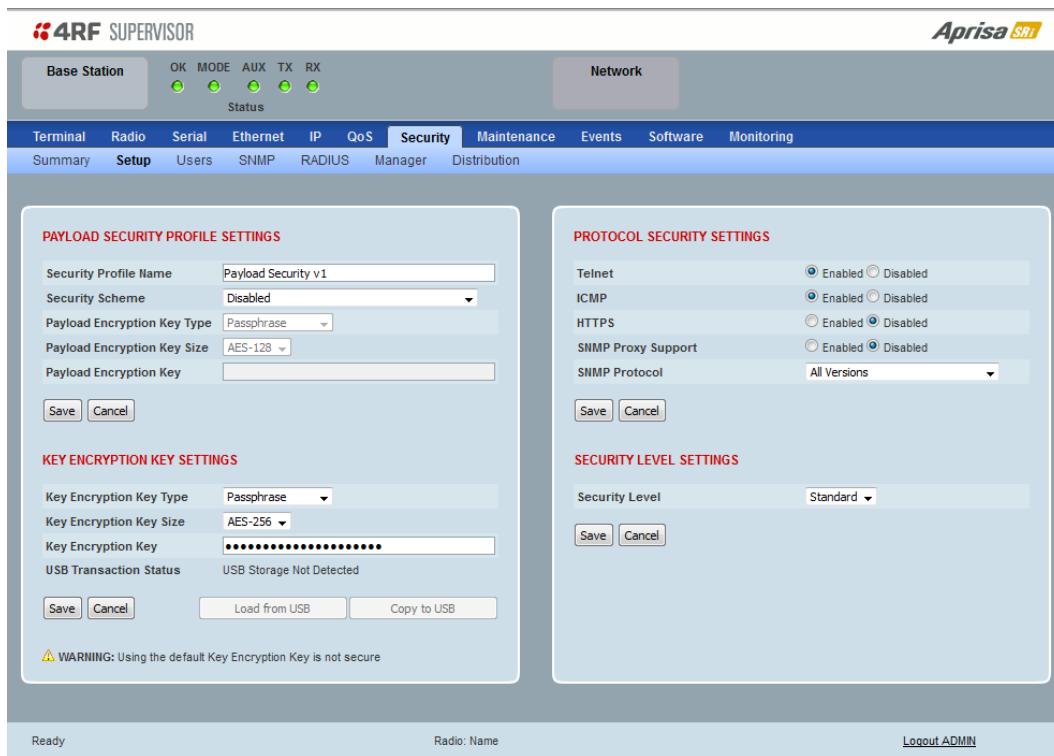

PAYLOAD SECURITY PROFILE SETTINGS

*Security Profile Name*

This parameter enables the user to predefine a security profile with a specified name.

*Security Scheme*

This parameter sets the security scheme to one of the values in the following table:

Security Scheme
Disabled (No encryption and no Message Authentication Code)
AES Encryption + CCM Authentication 128 bit
AES Encryption + CCM Authentication 64 bit
AES Encryption + CCM Authentication 32 bit
AES Encryption only
CCM Authentication 128 bit
CCM Authentication 64 bit
CCM Authentication 32 bit

The default setting is Disabled.

### *Payload Encryption Key Type*

This parameter sets the Payload Encryption Key Type:

Option	Function
Pass Phrase	Use the Pass Phrase password format for standard security.
Raw Hexadecimal	Use the Raw Hexadecimal key format for better security. It must comply with the specified encryption key size e.g. if Encryption Type to AES128, the encryption key must be 16 bytes (32 chars)

The default setting is Pass Phrase.

### *Payload Encryption Key Size*

This parameter sets the Encryption Type to AES128, AES192 or AES256. The default setting is AES128.

The higher the encryption size the better the security.

### *Payload Encryption Key*

This parameter sets the Payload Encryption password. This key is used to encrypt the payload.

#### Pass Phrase

Good password policy:

- contains at least eight characters, and
- contains at least one upper case letter, and
- contains at least one lower case letter, and
- contains at least one digit or another character such as @+... , and
- is not a term in a familiar language or jargon, and
- is not identical to or derived from the accompanying account name, from personal characteristics or from information from one's family/social circle, and
- is easy to remember, for instance by means of a key sentence

#### Raw Hexadecimal

The Raw Hexadecimal key must comply with the specified encryption key size e.g. if Encryption Type to AES128, the encryption key must be 16 bytes (32 chars).

## KEY ENCRYPTION KEY SETTINGS

The Key Encryption Key provides the ability to encrypt the Payload Encryption Key so it can be safely transmitted over the radio link to remote radios.

The Key Encryption Key Type, Key Encryption Key Size and Key Encryption Key must be the same on all radios in the network.

### *Key Encryption Key Type*

This parameter sets the Payload Encryption Key Type:

Option	Function
Pass Phrase	Use the Pass Phrase password format for standard security.
Raw Hexadecimal	Use the Raw Hexadecimal key format for better security. It must comply with the specified encryption key size e.g. if Encryption Type to AES128, the encryption key must be 16 bytes (32 chars)

The default setting is Pass Phrase.

### *Key Encryption Key Size*

This parameter sets the Encryption Type to AES128, AES192 or AES256. The default setting is AES128.

The higher the encryption type the better the security.

### *Key Encryption Key*

This parameter sets the Key Encryption Key. This is used to encrypt the payload encryption key.

### *USB Transaction Status*

This parameter shows if a USB flash drive is plugged into the radio host port .

Option	Function
USB Storage Not Detected	A USB flash drive is not plugged into the radio host port.
USB Storage Detected	A USB flash drive is plugged into the radio host port.

---

Note: Some brands of USB flash drives may not work with 4RF radios.

---

## Controls

The 'Save' button saves the Key Encryption Key settings to the radio. If the Security Level is set to Strong (see 'Security Level' on page 170), this button will be grayed out.

The 'Load From USB' button loads the Key Encryption Key settings from the USB flash drive. If a USB flash drive is not detected, this button will be grayed out.

The 'Copy To USB' button copies the Key Encryption Key settings to a file called 'asrkek.txt' on the USB flash drive. This settings file can be used to load into other radios. If a USB flash drive is not detected or the Security Level is set to Strong (see 'Security Level' on page 170), this button will not be shown.

## Key Encryption Key Summary

The security of over-the-air-rekeying depends on a truly random Key Encryption Key. This is why the use of a Raw Hexadecimal key is recommended as a plain text phrase based on known spelling and grammar constructs is not very random. The *default* Key Encryption Key is provided only to allow testing of the security mechanism and is not intended for operational use. Using the default Key Encryption Key undermines the security of the AES payload encryption because an attacker using the default Key Encryption Key would immediately recover the AES payload key after the first over-the-air-rekeying event.

When the Security Level is set to Strong, various protections are applied to the Key Encryption Key setting to prevent tampering. In addition, the Key Encryption Key Type, Key Encryption Key Size, and the Key Encryption Key itself are all loaded from a customer prepared USB key. This is a one way operation to prevent key recovery from radios. While the ability to save a Key Encryption Key to USB exists in Standard Security Level, the Strong Security Level Key Encryption Key is not compromised because the Strong Key Encryption Key is not the same as the Standard Security Level Key Encryption Key.

## PROTOCOL SECURITY SETTINGS

### *Telnet option*

This parameter option determines if you can manage the radio via a Telnet session. The default setting is disabled.

### *ICMP option (Internet Control Message Protocol)*

This parameter option determines whether the radio will respond to a ping. The default setting is disabled.

### *HTTPS option*

This parameter option determines if you can manage the radio via a HTTPS session (via a Browser). The default setting is enabled.

### *SNMP Proxy Support*

This parameter option enables an SNMP proxy server in the base station. This proxy server reduces the radio link traffic during SNMP communication to remote stations. This option applies to the base station only. The default setting is disabled.

This option can also be used if the radio has Serial Only interfaces.

### *SNMP Protocol*

This parameter sets the SNMP Protocol:

Option	Function
Disabled	All SNMP functions are disabled.
All Versions	Allows all SNMP protocol versions.
SNMPv3 Only	Only SNMPv3 transactions will be accepted including authenticated or encrypted transactions
SNMPv3 With Authentication Only	Only SNMPv3 transactions authenticated using HMAC-MD5 or HMAC-SHA will be accepted (as per table below).
SNMPv3 With Encryption Only	Only SNMPv3 transactions with an encrypted type of DES or AES will be accepted (as per table below).

The default setting is All Versions.

The default SNMPv3 with Authentication User Details provided are:

User Name	Encryption Type	Authentication Type	Context Name	Authentication Passphrase	Encryption Passphrase
noAuthUser	-	-	noAuth	noAuthUser	noAuthUser
desUserMD5	DES	MD5	priv	desUserMD5	desUserMD5
desUserSHA	DES	SHA	priv	desUserSHA	desUserSHA
authUserMD5	-	MD5	auth	authUserMD5	authUserMD5
authUserSHA	-	SHA	auth	authUserSHA	authUserSHA
privUserMD5	AES	MD5	priv	privUserMD5	privUserMD5
privUserSHA	AES	SHA	priv	privUserSHA	privUserSHA



## SNMPv3 Authentication Passphrase

The SNMPv3 Authentication Passphrase can be changed via the SNMPv3 secure management protocol interface (not via SuperVisor).

When viewing / managing the details of the users via SNMPv3, the standard SNMP-USER-BASED-SM-MIB interface is used. This interface can be used to change the SNMPv3 Authentication Passphrase of the users.

The SNMPv3 Authentication Passphrase of a user required to be changed cannot be changed by the same user i.e. a different user must be used for the transactions.

### Generate New Keys from SNMPv3 USM User Passphrases

Net-SNMP is a suite of open source software for using and deploying the SNMP protocol. Similar functionality is built into many commercial SNMP managers.

This next step of loading the Aprisa SRi radios with keys generated from USM user passphrases requires the SNMPv3 USM Management utility provided as part of NET-SNMP.

The utility is called 'snmpusm'. It provides a range of commands including the management of changing passwords for SNMPv3 users. In order to use this utility, the user will need to install NET-SNMP on a Linux (or Windows®) or machine. The examples below are from the Linux environment. This tool automatically obtains the engine ID from the target radio before generating the keys and loading them into the target.

### To change a user authentication passphrase:

The following are examples of:

#### Changing the privUserSHA user encryption key / password from privUserSHA to privUserSHANew:

```
c:\usr\bin>snmpusm -v 3 -u privUserSHA -n priv -l authPriv -a SHA -A privUserSHA -x AES -X privUserSHA -Cx 172.17.70.17 passwd privUserSHA privUserSHANew
```

#### Changing the privUserSHA user authentication key / password from privUserSHA to privUserSHANew:

```
c:\usr\bin>snmpusm -v 3 -u privUserSHA -n priv -l authPriv -a SHA -A privUserSHA -x AES -X privUserSHANew -Ca 172.17.70.17 passwd privUserSHA privUserSHANew
```

#### Changing the desUserSHA user encryption key / password from desUserSHA to desUserSHANew:

```
c:\usr\bin>snmpusm -v 3 -u desUserSHA -n priv -l authPriv -a SHA -A desUserSHA -x DES -X desUserSHA -Cx 172.17.70.17 passwd desUserSHA desUserSHANew
```

#### Changing the desUserSHA user authentication key / password from desUserSHA to desUserSHANew:

```
c:\usr\bin>snmpusm -v 3 -u desUserSHA -n priv -l authPriv -a SHA -A desUserSHA -x DES -X desUserSHANew -Ca 172.17.70.17 passwd desUserSHA desUserSHANew
```

#### Changing the privUserMD5 user encryption key / password from privUserMD5 to privUserMD5New:

```
c:\usr\bin>snmpusm -v 3 -u privUserMD5 -n priv -l authPriv -a MD5 -A privUserMD5 -x AES -X privUserMD5 -Cx 172.17.70.17 passwd privUserMD5 privUserMD5New
```

#### Changing the privUserMD5 user authentication key / password from privUserMD5 to privUserMD5New:

```
c:\usr\bin>snmpusm -v 3 -u privUserMD5 -n priv -l authPriv -a MD5 -A privUserMD5 -x AES -X privUserMD5New -Ca 172.17.70.17 passwd privUserMD5 privUserMD5New
```

Changing the desUserMD5 user encryption key / password from desUserMD5 to desUserMD5New:

```
c:\usr\bin>snmpusm -v 3 -u desUserMD5 -n priv -l authPriv -a MD5 -A desUserMD5 -x DES -X  
desUserMD5 -Cx 172.17.70.17 passwd desUserMD5 desUserMD5New
```

Changing the desUserMD5 user authentication key / password from desUserMD5 to desUserMD5New:

```
c:\usr\bin>snmpusm -v 3 -u desUserMD5 -n priv -l authPriv -a MD5 -A desUserMD5 -x DES -X  
desUserMD5New -Ca 172.17.70.17 passwd desUserMD5 desUserMD5New
```

Changing the authUserSHA user authentication key / password from authUserSHA to authUserSHANew:

```
c:\usr\bin>snmpusm -v 3 -u authUserSHA -n auth -l authNoPriv -a SHA -A authUserSHA -Ca  
172.17.70.17 passwd authUserSHA authUserSHANew
```

Changing the authUserMD5 user authentication key / password from authUserMD5 to authUserMD5New:

```
c:\usr\bin>snmpusm -v 3 -u authUserMD5 -n auth -l authNoPriv -a MD5 -A authUserMD5 -Ca  
172.17.70.17 passwd authUserMD5 authUserMD5New
```

*Notes*

-Cx option is to change the Encryption key/password

-Ca option is to change the Authentication key/password

Other information on this utility can be obtained from the utility command help itself or online

*Summary*

It is necessary to record the new passphrases loaded into the Aprisa SRi radios and then load the passphrases into the SNMP manager. There is a separate passphrase for the two supported forms of authentication (MD5 and SHA1) only as well as the two forms of authentication used in combination the two forms of encryption (DES and AES). It is vital to change all passphrases even if the deprecated mechanism are not used (MD5 and DES) otherwise an attacker could still use the default passphrases.

## Reset Unknown Passphrases with the Command Line Interface

As it is not possible for users to read previously set passphrases, a CLI command is available from Aprisa SRi software release 1.4.0 to 'reset' the SNMPv3 USM users back to defaults.

---

**Note:** USM users are not related to CLI and SuperVisor users. This command will only be accessible to the CLI 'admin' user logins.

---

### To reset unknown passphrases:

1. Telnet into each radio in the network and via the CLI reset the passphrases
2. Login to the radio with:  
    Login: admin  
    Password: \*\*\*\*\*
3. Set all SNMP3 users to default values with the 'snmpusm reset' command (see 'SNMP3 users to default values' below for the list of default values).
4. Reboot the radio with the 'reboot' command.

## SECURITY LEVEL SETTINGS

### Security Level

This parameter sets the Security Level active security features. The default setting is Standard.

Option	Payload Encryption	HTTPS	SNMPv3	USB KEK Only
Standard	✓	✓	✓	
Strong	✓	✓	✓	✓

If the Security Level is reduced, there will be a pop up message warning that Key Encryption Key will be reset to the default value.

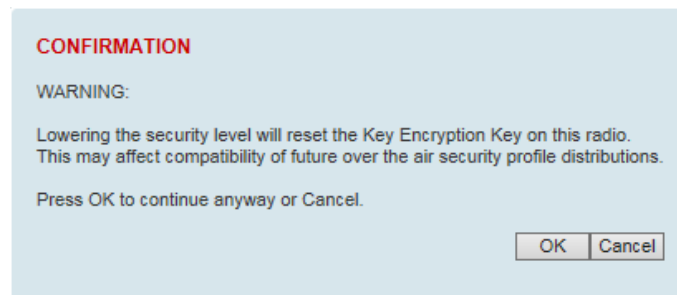

If the Security Level is increased, there will be a pop up message reminding user to enter a new Key Encryption Key.

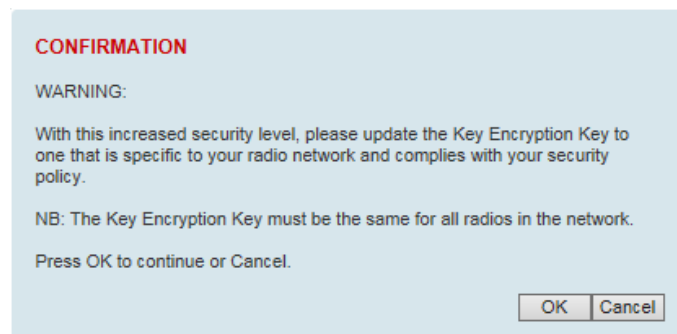

If the Security Level is set to Strong, the 'Save' button will be grayed out and the 'Copy To USB' button will not be shown.

### SNMPv3 Context Addressing

SNMPv3 is not user configurable and user can use this option with any NMS. The radio SNMP management interface supports SNMPv3/2 context addressing. The SNMv3 context addressing allows the user to use secure SNMPv3 management while improving NMS performance.

A NMS (Network Management System) can access any remote radio directly by using its IP address or via the base / master station SNMPv3 context addressing. The SNMPv3 context addressing can compress the SNMPv3 management traffic OTA (Over The Air) to the remote station by up to 90% relative to direct OTA SNMPv3 access to remote station, avoiding the radio narrow bandwidth traffic loading.

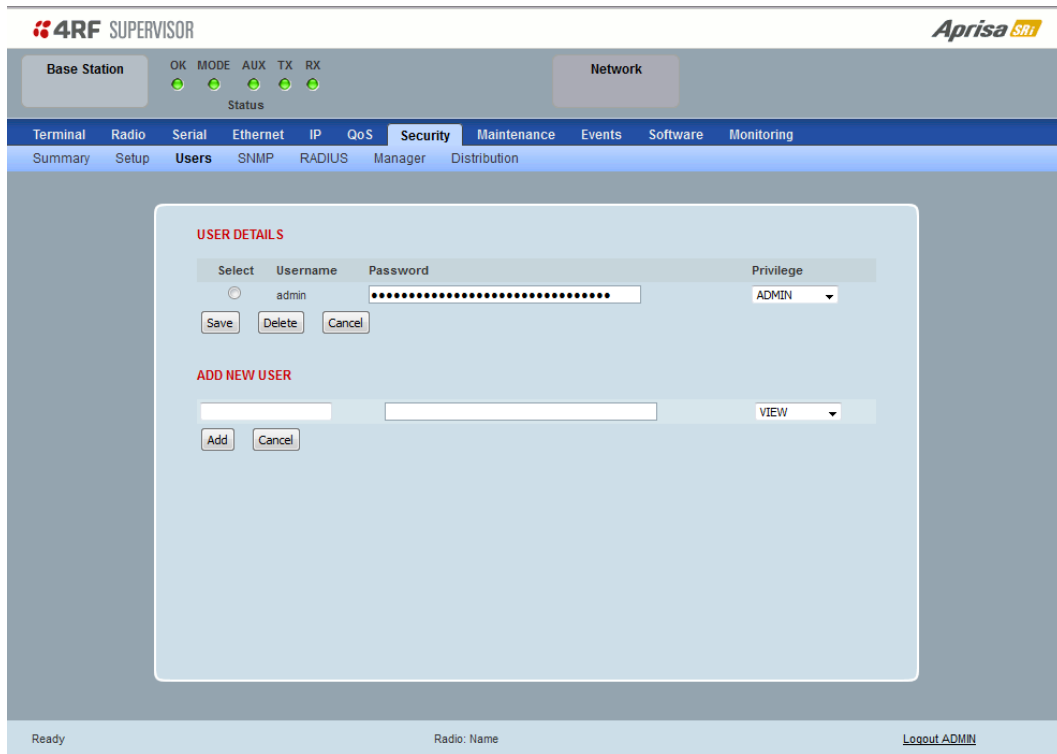

**Note:** You must login with ‘admin’ privileges to add, disable, delete a user or change a password.

### USER DETAILS

Shows a list of the current users setup in the radio.

### ADD NEW USER

To add a new user:

1. Enter the Username.

A username can be up to 32 characters but cannot contain back slashes, forward slashes, spaces, tabs, single or double quotes. Usernames are case sensitive.

2. Enter the Password.

A password can be 8 to 32 printable characters but cannot contain a tab. Passwords are case sensitive.

Good password policy:

- contains at least eight characters, and
- contains at least one upper case letter, and
- contains at least one lower case letter, and
- contains at least one digit or another character such as `!@#$$%^&(){}[]<>... ,` and
- is not a term in a familiar language or jargon, and
- is not identical to or derived from the accompanying account name, from personal characteristics or from information from one’s family/social circle, and
- is easy to remember, for instance by means of a key sentence

3. Select the User Privileges

There are four pre-defined User Privilege settings to allocate access rights to users. These user privileges have associated default usernames and passwords of the same name.

The default login is 'admin'.

This login has full access to all radio parameters including the ability to add and change users. There can only be a maximum of two usernames with admin privileges and the last username with admin privileges cannot be deleted.

User Privilege	Default Username	Default Password	User Privileges
View	view	view	Users in this group can only view the summary pages.
Technician	technician	technician	Users in this group can view and edit parameters except Security > Users and Security > Setup.
Engineer	engineer	engineer	Users in this group can view and edit parameters except Security > Users.
Admin	admin	admin	Users in this group can view and edit all parameters.

See 'SuperVisor Menu Access' on page 76 for the list of SuperVisor menu items versus user privileges.

#### 4. Click 'Add'

#### To delete a user:

1. Select Terminal Settings > Security > Users
2. Click on the Select button for the user you wish to delete.
3. Click 'Delete'

#### To change a Password:

1. Select Terminal Settings > Security > Users
2. Click on the Select button for the user you wish to change the Password.
3. Enter the Password.

A password can be 8 to 32 characters but cannot contain back slashes, forward slashes, spaces, tabs, single or double quotes.

## Security &gt; SNMP

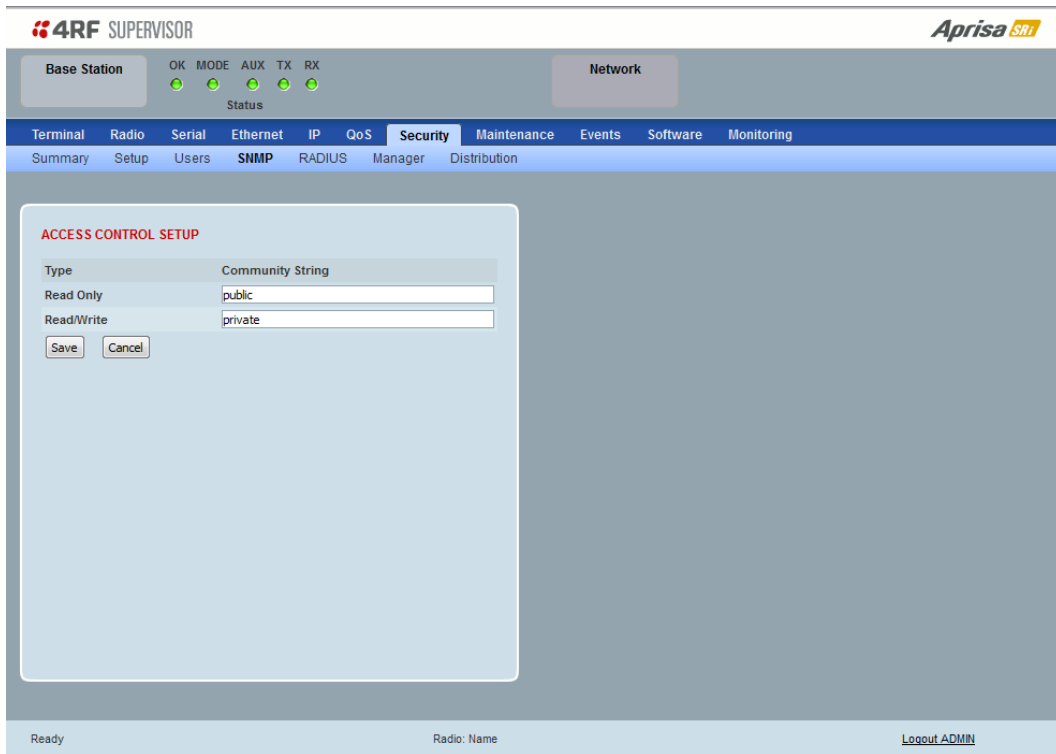

In addition to web-based management (SuperVisor), the network can also be managed using the Simple Network Management Protocol (SNMP) using any version of SNMP v1/2/3. MIB files are supplied, and these can be used by a dedicated SNMP Manager, such as Castle Rock’s SNMPC, to access most of the radio’s configurable parameters.

For communication between the SNMP manager and the radio, Access Controls and Community strings must be set up as described in the following sections.

A SNMP **Community String** is used to protect against unauthorized access (similar to a password). The SNMP agent (radio or SNMP manager) will check the community string before performing the task requested in the SNMP message.

#### ACCESS CONTROL SETUP

A SNMP **Access Control** is the IP address of the radio used by an SNMP manager or any other SNMP device to access the radio. The Aprisa SRi allows access to the radio from any IP address.

##### *Read Only*

The default Read Only community string is public.

##### *Read Write*

The default ReadWrite community string is private.

## SNMP Manager Setup

The SNMP manager community strings must be setup to access the base station and remote stations.

To access the base station, a community string must be setup on the SNMP manager the same as the community string setup on the radio (see ‘Security > SNMP’ on page 173).

SNMP access to remote stations can be achieved by using the radio’s IP address and the normal community string or by proxy in the base station.

### SNMP Access via Base Station Proxy

To access the remote stations via the base station proxy, the community strings must be setup on the SNMP manager in the format:

ccccccccc:bbbbbb

Where:

ccccccccc is the community string of the base station

and

bbbbbb is the last 3 bytes of the remote station MAC address (see ‘Network Status > Network Table’ on page 246).

The SNMP Proxy Support must be enabled for this method of SNMP access to operate (see ‘SNMP Proxy Support’ on page 166).



## Security > RADIUS

This page displays the current settings for the Security RADIUS.

**RADIUS AUTHENTICATION SETTINGS**

Authentication Mode: Local Authentication

Primary Server: None

Secondary Server: None

**RADIUS ACCOUNTING SETTINGS**

Primary Server: None

Secondary Server: None

**RADIUS ADVANCED SETTINGS**

Initial Transaction Timeout(s): 4

Default Transaction Timeout(s): 16

Maximum Retries: 5

Maximum Retries Duration (s): 30

Unknown Transaction Attributes: Ignore And Authenticate

**RADIUS SERVER SETTINGS**

Server Name	IP Address	Port Number	Encryption Key
1 Radius Server 1	0.0.0.0	1812	.....
2 Radius Server 2	0.0.0.0	1812	.....
3 Radius Server 3	0.0.0.0	1813	.....
4 Radius Server 4	0.0.0.0	1813	.....

Save Cancel

Ready Radio: Name Logout ADMIN

### RADIUS - Remote Authentication Dial In User Service

RADIUS is a client / server system that secures the radio link against unauthorized access. It is based on open standard RFCs: RFC 2865/6, 5607, 5080 and 2869. It is used for remote user Authorization, Authentication and Accounting.

When a user logs into a radio with RADIUS enabled, the user's credentials are sent to the RADIUS server for authentication of the user.

Transactions between the RADIUS client and RADIUS server are authenticated through the use of a shared secret, which is never sent over the network.

For a RADIUS server to respond to the radio, it must be configured with and respond to the following **Management-Privilege-level** attributes:

- Admin Level = 4
- Technician Level = 2
- Viewer Level = 1

A RADIUS server can act as a proxy client to other RADIUS servers or other kinds of authentication servers.

## RADIUS AUTHENTICATION SETTINGS

### *Authentication Mode*

This parameter sets the Authentication Mode.

Option	Function
Local Authentication	No radius Authentication - allows any local user privilege
Radius Authentication	Only radius Authentication - no local user privilege
Radius Authentication and Local admin	Uses radius Authentication if it is available. If radius Authentication is not available, uses local Admin login
Radius Then Local Authentication	If the user is not authenticated in the radius server, it allows any local user privilege.
Local Then Radius Authentication	If the user is not allowed in the local user privilege, radius authentication is used.

### *Primary Server*

This parameter sets which radius server is used as the primary server for authentication. Select one of the possible authentication servers setup in Radius Server Settings.

### *Secondary Server*

This parameter sets which radius server is used as the secondary server for authentication. Select one of the possible authentication servers setup in Radius Server Settings.

## RADIUS ACCOUNTING SETTINGS

### *Primary Server*

This parameter sets which radius server is used as the primary server for accounting (log of user activity). Select one of the possible accounting servers setup in Radius Server Settings.

### *Secondary Server*

This parameter sets which radius server is used as the secondary server for accounting. Select one of the possible accounting servers setup in Radius Server Settings.

## RADIUS ADVANCED SETTINGS

### *Initial Transaction Timeouts (IRT) (seconds)*

This parameter sets the initial time to wait before the retry mechanism starts when the server is not responding.

### *Default Transaction Timeouts (MRT) (seconds)*

This parameter sets the maximum time between retries.

### *Maximum Retries (MRC)*

This parameter sets the maximum number of retry attempts when the server is not responding.

### *Maximum Retries Duration (MRD) (seconds)*

This parameter sets the maximum duration it will attempt retries when the server is not responding.

### *Unknown Transaction Attributes*

This parameter sets the radio's response to unknown attributes received from the radius server.

Option	Function
Ignore and Authenticate	Ignore the unknown attributes and accept the authentication received from the radius server
Reject and Deny	Reject the authentication received from the radius server

## RADIUS SERVER SETTINGS

### *Server Name*

You can enter up to four radius servers 1-4.

### *IP Address*

The IP address of the Radius server.

### *Port Number*

The Port Number of the Radius server. RADIUS uses UDP as the transport protocol.

- UDP port 1812 is used for authentication / authorization
- UDP port 1813 is used for accounting.

Old RADIUS servers may use unofficial UDP ports 1645 and 1646.

### *Encryption Key*

The password of the Radius server.

Security > Manager

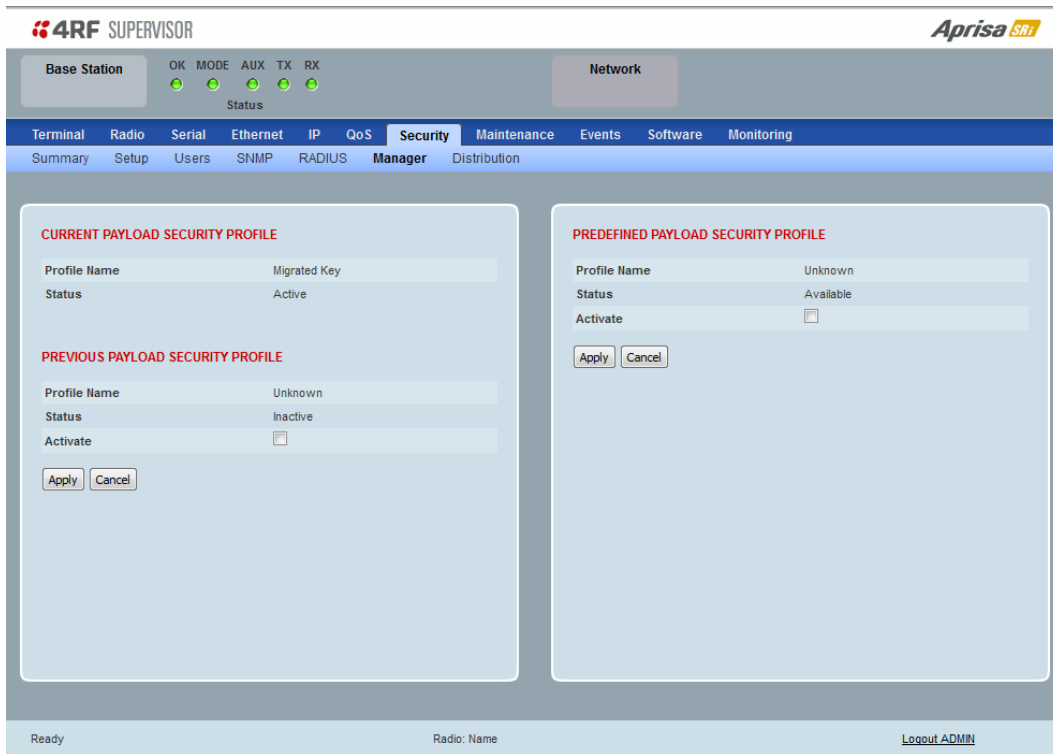

CURRENT PAYLOAD SECURITY PROFILE

*Profile Name*

This parameter shows the predefined security profile active on the radio.

*Status*

This parameter displays the status of the predefined security profile on the radio (always active).

PREVIOUS PAYLOAD SECURITY PROFILE

*Profile Name*

This parameter displays the security profile that was active on the radio prior to the current profile being activated.

*Status*

This parameter displays the status of the security profile that was active on the radio prior to the current profile being activated.

Option	Function
Active	The security profile is active on the radio.
Inactive	The security profile is not active on the radio but could be activated if required.

### *Activate*

This parameter activates the previous security profile (restores to previous version).

### PREDEFINED PAYLOAD SECURITY PROFILE

#### *Profile Name*

This parameter displays the new security profile that could be activated on the radio or distributed to all remote radios with Security > Distribution.

#### *Status*

This parameter displays the status of the new security profile.

Option	Function
Unavailable	A predefined security profile is not available on this radio. To create a predefined security profile, go to 'Security > Setup' on page 162.
Available	A predefined security profile is available on this radio for distribution and activation.

Security > Distribution

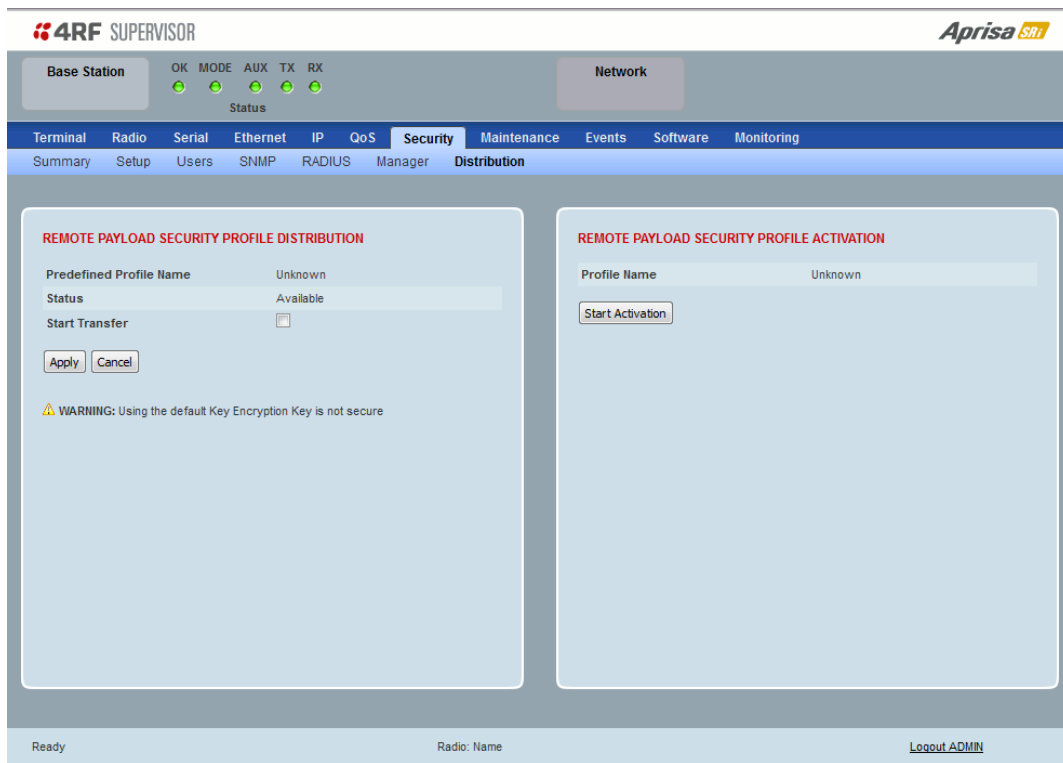

REMOTE PAYLOAD SECURITY PROFILE DISTRIBUTION

*Predefined Profile Name*

This parameter displays the predefined security profile available for distribution to remote stations.

*Status*

This parameter shows if a predefined security profile is available for distribution to remote stations.

Option	Function
Unavailable	A predefined payload security profile is not available on this radio.
Available	A predefined payload security profile is available on this radio for distribution and activation.

*Start Transfer*

This parameter when activated distributes (broadcasts) the new payload security profile to all remote stations in the network.

---

**Note:** The distribution of the payload security profile to remote stations does not stop customer traffic from being transferred.

Payload security profile distribution traffic is classified as ‘management traffic’ but does not use the Ethernet management priority setting. Security profile distribution traffic priority has a fixed priority setting of ‘very low’.

---

**To distribute the payload security profile to remote stations:**

This process assumes that a payload security profile has been setup (see 'Security > Setup' on page 162).

1. Tick Start Transfer and click Apply.

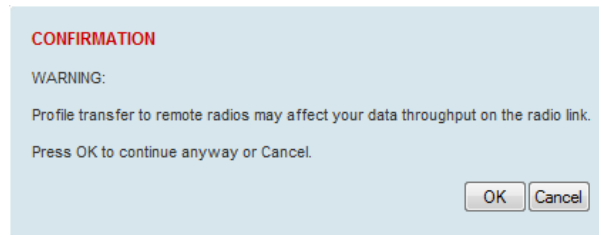

---

**Note:** This process could take up to 1 minute per radio depending on channel size, Ethernet Management Priority setting and the amount of customer traffic on the network.

---

2. When the distribution is completed, activate the software with the Remote Payload Security Profile Activation.

## REMOTE PAYLOAD SECURITY PROFILE ACTIVATION

When the security profile has been distributed to all the remote stations, the security profile is then activated in all the remote stations with this command.

The base station will always attempt to distribute the profile successfully. This broadcast distribution has its own retry mechanism. The user can find out if all the remote radios have the latest profile when the managed activation process is attempted. A pop up confirmation will be shown by SuperVisor with relevant information and the user can decide to proceed or not. The user can attempt to redistribute again if needed. If the decision is made to continue, on completion of the activation process, communication with the remote radios that did not have the new security profile will be lost.

### *Predefined Profile Name*

This parameter displays the predefined security profile available for activation on all remote stations.

### To activate the security profile in remote stations:

This process assumes that a security profile has been setup into the base station (see 'Security > Setup' on page 162) and distributed to all remote radios in the network.

---

**Note:** Do not navigate SuperVisor away from this page during the activation process (SuperVisor can lose PC focus).

---

#### 1. Click Start Activation

The remote stations will be polled to determine which radios require activation:

Result	Function (X of Y)
Remote Radios Polled for New Profile	X is the number of radios polled to determine if the radio contains the new security profile. Y is the number of remote radios registered with the base station.
Remote Radios Activated	X is the number of radios activated. Y is the number of radios with the new security profile requiring activation.
Remote Radios On New Profile	X is the number of radios activated and on the new security profile. Y is the number of radios with the new security profile that have been activated.

When the activation is ready to start:

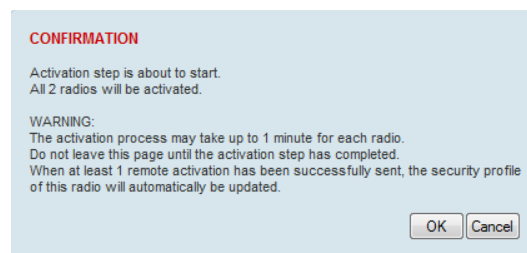

#### 3. Click on 'OK' to start the activation process or Cancel to quit.



## Maintenance

### Maintenance > Summary

This page displays the current settings for the Maintenance parameters.

#### GENERAL

##### *Local Status Polling Period (sec)*

This parameter displays the rate at which SuperVisor refreshes the Local Radio alarm LED states and RSSI value.

##### *Remote Status Polling Period (sec)*

This parameter displays the rate at which SuperVisor refreshes the Remote Radio alarm LED states and RSSI value.

##### *Network View Polling Period (sec)*

This parameter displays the rate at which SuperVisor polls all remote radios for status and alarm reporting.

##### *Inactivity Timeout (min)*

This parameter displays the period of user inactivity before SuperVisor automatically logs out of the radio.

##### *Frequency Tracking*

This parameter displays if Frequency Tracking is enabled or disabled.

## NETWORK

### *Node Registration Retry (sec)*

This parameter displays the base station poll time at startup or the remote station time between retries until registered.

### *Announcement Period (min)*

This parameter displays the period between base station polls post startup. The default setting is 1440 minutes (24 hours).

### *Node Missed Poll Count*

This parameter displays the number of times the base station attempts to poll the network at startup or if a duplicate IP is detected when a remote station is replaced.

## UPGRADE

### *USB Boot Cycle Upgrade*

This parameter shows the type of USB Boot Cycle upgrade defined in 'Software Setup > USB Boot Upgrade' on page 211.

## LICENCE

### *Remote Management*

This parameter displays if Remote Management is enabled or disabled. The default setting is enabled.

### *Ethernet OTA (over the air)*

This parameter displays if Ethernet traffic is enabled or disabled. The Ethernet OTA will be enabled if the Ethernet feature licence has been purchased (see 'Maintenance > Licence' on page 191).

### *SNMP Management*

This parameter displays if SNMP management is enabled or disabled. The default setting is enabled.

## Maintenance &gt; General

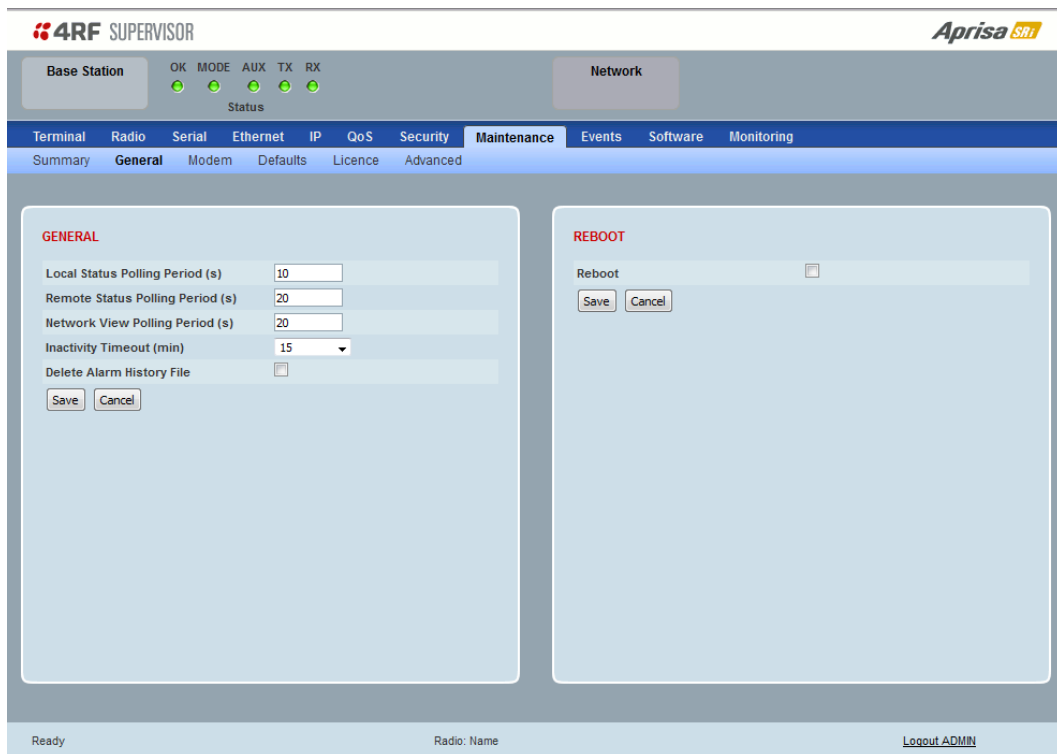
**GENERAL**
*Local Status Polling Period (sec)*

This parameter sets the rate at which SuperVisor refreshes the Local Radio alarm LED states and RSSI value. The default setting is 10 seconds.

*Network View Polling Period (sec)*

This parameter sets the rate at which SuperVisor polls all remote radios for status and alarm reporting. The default setting is 20 seconds.

*Remote Status Polling Period (sec)*

This parameter sets the rate at which SuperVisor refreshes the Remote Radio alarm LED states and RSSI value. To avoid problems when managing Aprisa SRi Networks, ensure that the Remote Polling Period is set to be longer than the Inband Management Timeout (set on page 82). The default setting is 20 seconds.

*Inactivity Timeout (min)*

This parameter sets the period of user inactivity before SuperVisor automatically logs out of the radio. The default setting is 15 minutes.

*Delete Alarm History file*

This parameter when activated deletes the alarm history file stored in the radio.

## REBOOT

### To reboot the radio:

1. Select Maintenance > General.
2. Tick the 'Reboot' checkbox.



3. Click 'Save' to apply the changes or 'Cancel' to restore the current value.

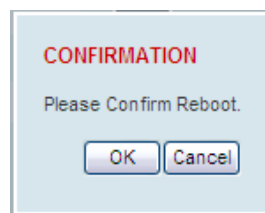

4. Click 'OK' to reboot the radio or 'Cancel' to abort.

All the radio LEDs will flash repeatedly for 1 second.

The radio will be operational again in about 10 seconds.

The OK, MODE, and AUX LEDs will light green and the TX and RX LEDs will be green (steady or flashing) if the network is operating correctly.

5. Login to SuperVisor.

## Maintenance &gt; Modem

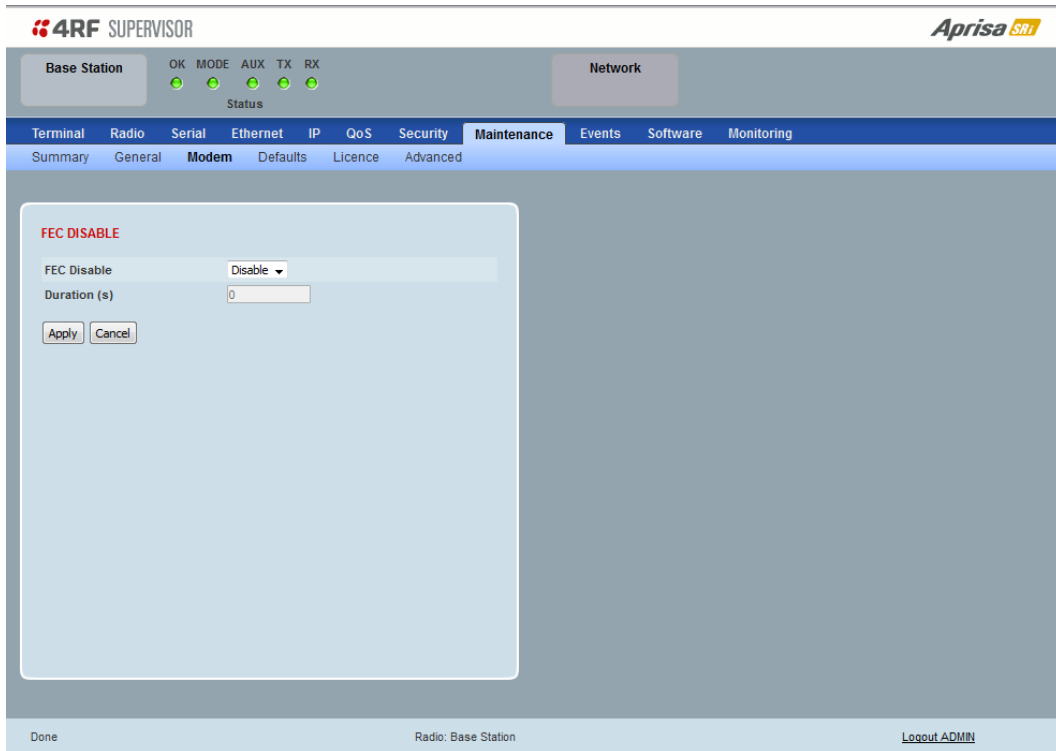
Base Station

**FEC DISABLE**
*FEC Disable*

This diagnostic function allows the user to temporarily disable forward error correction on the channel when diagnosing problems on the link.

Therefore, enabling this diagnostic function would temporarily disable FEC on the channel and the associated maintenance mode alarm would activate.

Note that the opposite is not true for this diagnostic function. In other words, this diagnostic function does not provide the user with the option to temporarily enable forward error correction on the channel.

All diagnostic functions are not persistent and will be return to disabled states should the system restart.

Option	Function
Enable	Enables the FEC Disable diagnostic function
Disable	Disables the FEC Disable diagnostic function
Timer	Allows the FEC to be disabled but only for a predetermined period.

*Duration (s)*

This parameter defines the period required for disabling of the FEC. When this period elapses, the FEC is enabled.

## Remote Station

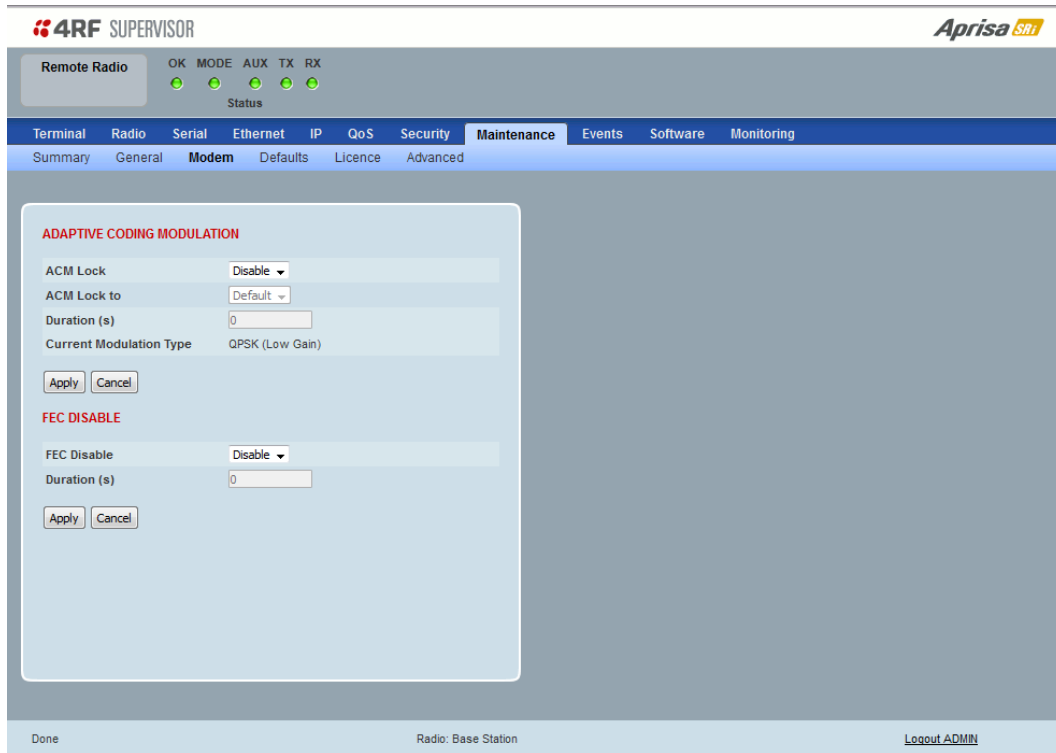

### ADAPTIVE CODING AND MODULATION

#### ACM Lock

This parameter sets whether adaptive modulation can be locked or not.

Option	Function
Disable	Disables manual locking of the adaptive modulation i.e. allows for automatic adaptive modulation.
Enable	Allows the adaptive modulation to be manually locked
Timer	Allows the adaptive modulation to be manually locked but only for a predetermined period.

#### ACM Lock To

This parameter manually locks the adaptive modulation.

Option	Function
Default	Manually locks the adaptive modulation to the default
Current	Manually locks the adaptive modulation to the current modulation at that time.

#### Duration (s)

This parameter defines the period required for manually locking the adaptive modulation. When this period elapses, the adaptive modulation becomes automatic.

## FEC DISABLE

### *FEC Disable*

This diagnostic function allows the user to temporarily disable forward error correction on the channel when diagnosing problems on the link.

Therefore, enabling this diagnostic function would temporarily disable FEC on the channel and the associated maintenance mode alarm would activate.

Note that the opposite is not true for this diagnostic function. In other words, this diagnostic function does not provide the user with the option to temporarily enable forward error correction on the channel.

All diagnostic functions are not persistent and will be return to disabled states should the system restart.

Option	Function
Enable	Enables the FEC Disable diagnostic function
Disable	Disables the FEC Disable diagnostic function
Timer	Allows the FEC to be disabled but only for a predetermined period.

### *Duration (s)*

This parameter defines the period required for disabling of the FEC. When this period elapses, the FEC is enabled.

## Maintenance &gt; Defaults

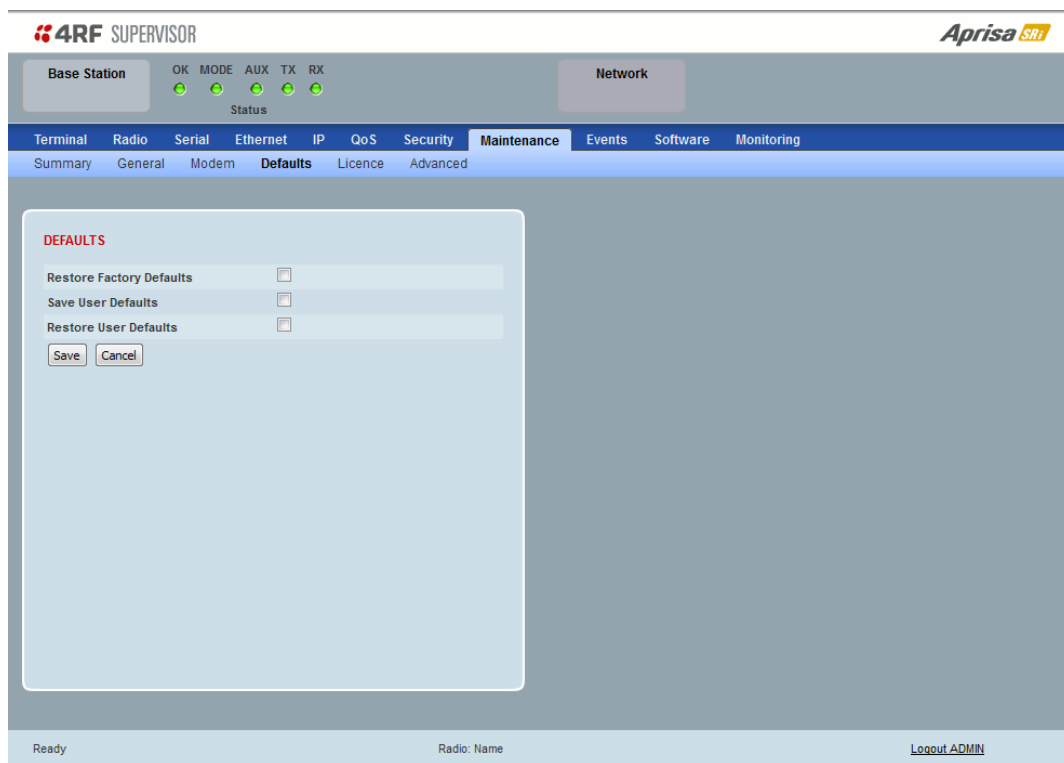

## DEFAULTS

The Maintenance Defaults page is only available for the local terminal.

*Restore Factory Defaults*

When activated, all radio parameters will be set to the factory default values. This includes resetting the radio IP address to the default of 169.254.50.10.

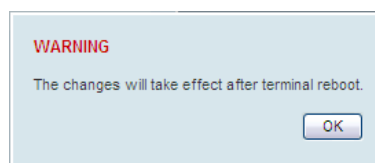

---

**Note:** Take care using this command.

---

*Save User Defaults*

When activated, all current radio parameter settings will be saved to non-volatile memory within the radio.

*Restore User Defaults*

When activated, all radio parameters will be set to the settings previously saved using 'Save User Defaults'.



## Maintenance &gt; Licence

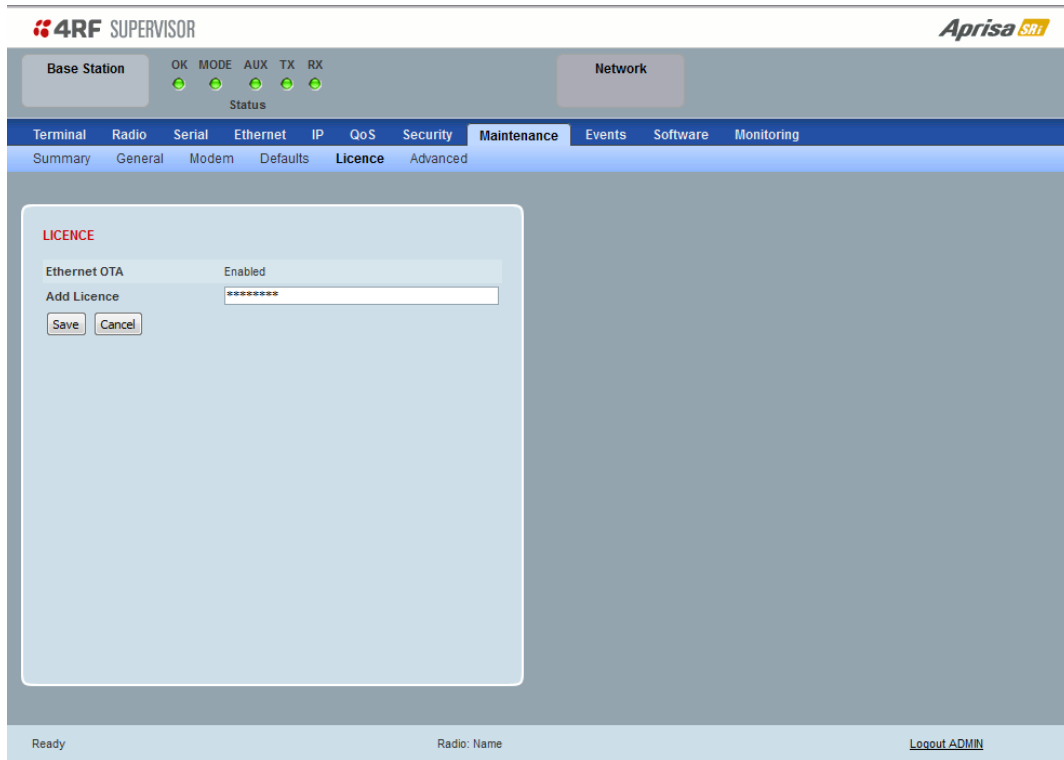

## LICENCE

In this software version, Remote Management, Ethernet Traffic and SNMP management are enabled by default.

## Maintenance &gt; Advanced

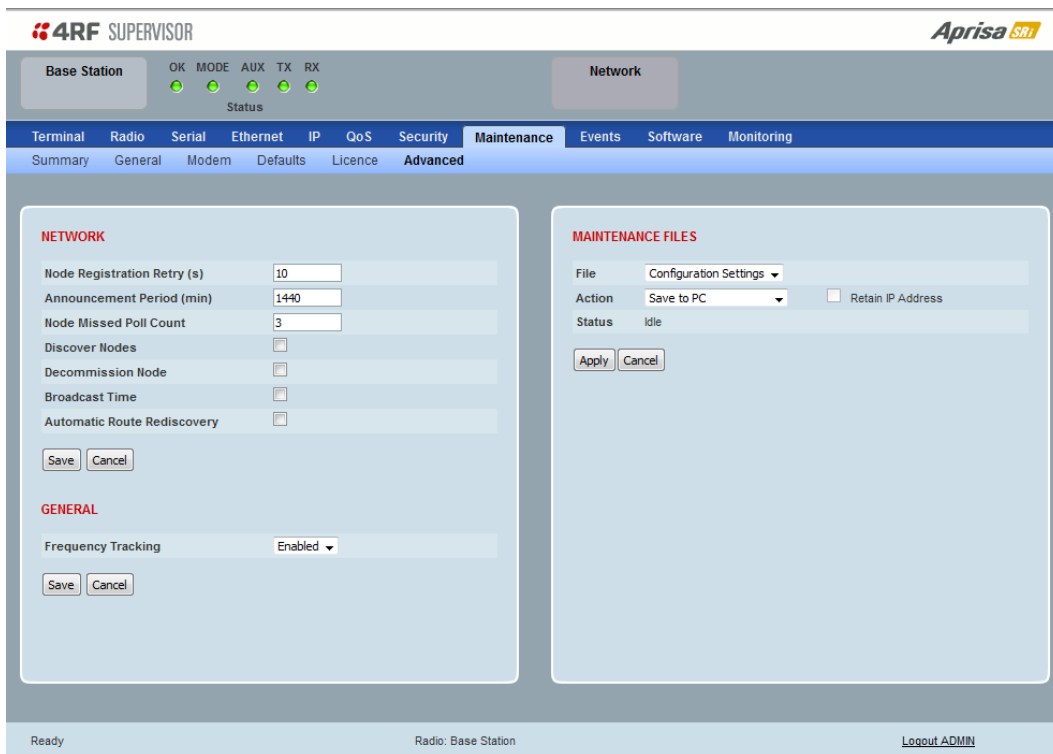

**4RF SUPERVISOR** **Aprisa SRI**

Base Station OK MODE AUX TX RX Network  
Status

Terminal Radio Serial Ethernet IP QoS Security **Maintenance** Events Software Monitoring  
 Summary General Modem Defaults Licence **Advanced**

**NETWORK**

Node Registration Retry (s)   
 Announcement Period (min)   
 Node Missed Poll Count   
 Discover Nodes   
 Decommission Node   
 Broadcast Time   
 Automatic Route Rediscovery

**GENERAL**

Frequency Tracking

**MAINTENANCE FILES**

File    
 Action    Retain IP Address  
 Status

Ready Radio: Base Station [Logout ADMIN](#)

## NETWORK

*Node Registration Retry (sec)*

This parameter sets the base station poll time at startup or the remote station time between retries until registered. The default setting is 10 seconds.

*Base Station Announcement Period (min)*

This parameter sets the period between base station polls post startup. The default setting is 1440 minutes (24 hours).

When a new base station powers on, it announces its presence and each remote that receives the announcement message will be advised that a new base station is present and that they should re-register. This allows the new base station to populate its Network Table, with knowledge of the nodes in the network.

If, during this initial period, there is some temporary path disturbance to one or more remotes, they may miss the initial announcement messages and be left unaware of the base station change. For this reason, the base station must periodically send out announcement messages to pick up any stray nodes and the period of these messages is the base station Announcement Period.

Setting this parameter to 0 will stop periodic announcement messages being transmitted.

If a critical parameter is changed in the base station, such as IP address, then the change is distributed to the network using base station announcement message. Note that in this case, an announcement is sent immediately independent of the Announcement Period setting.

### *Node Missed Poll Count*

This parameter sets the number of times the base station attempts to poll the network at startup or if a duplicate IP is detected when a remote station is replaced. The default setting is 3.

### *Discover Nodes*

This parameter when activated triggers the base station to poll the network with Node Missed Poll Count and Node Registration Retry values.

### *Decommission Node(s)*

This parameter when activated resets the network registrations to remove the entire network from service.

---

**Note:** Take care using this option.

---

### *Broadcast Time*

This parameter when activated sends the base station Date / Time setting to all the remote stations in the network and sets their Date / Time. This option applies to the base station only.

### *Automatic Route Rediscovery*

This parameter enables the radio to transmit route discovery messages when packets are unacknowledged.

When enabled, unacknowledged unicast packets are converted into uni-broadcast messages and sent through the network. All nodes see the message and populate their routing tables accordingly.

When the destination node is reached, it sends a route response message via the shortest path. The intermediate nodes see this message and populate their routing tables in the reverse direction, thus re-establishing the route.

The default setting is disabled.

### *Delete Received Channel List - Remote Radios Only*

This parameter deletes the existing zone channel list and uses the configured zone channel allocation setup with Zone Setup on page 101 until it re-registers with the base station and receives the new distributed zone channel list.

## GENERAL

### *Frequency Tracking*

Frequency Tracking enables the receiver to track any frequency drift in the transmitter to maintain optimum SNR and radio link performance over the full temperature range.

When enabled, remote stations adjust their receive frequency to the frequency of the incoming packet rate and the base station notifies remote stations if their transmit frequency requires adjustment.

The default setting is Enabled.

## MAINTENANCE FILES

There are three maintenance file types which can be saved / restored to / from PC or USB flash drive:

---

Note: Some brands of USB flash drives may not work with 4RF radios.

---

### File - Configuration Settings

#### Action

Action	Option
Save to PC	This saves the file with a filename of 'Config.4' to a binary encrypted file. This can then be saved from the Browser popup (example is Windows Internet Explorer 11). The file should be renamed to be able to identify the radio it was saved from.

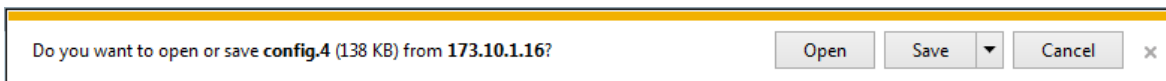

Save to Radio USB	This saves the file with a filename of 'asrcfg_1.0.0' to a binary encrypted file on the radio USB flash drive root directory.
Restore from PC	This restores all user configuration settings from a binary encrypted file on a PC directory to the radio. A reboot warning message will warn of a pending reboot after the PC file is selected. Clicking OK will open a browser file selection window to select the file. <b>Note:</b> If you are using Explorer, it must be IE10 or above for this feature to work correctly.
Restore from Radio USB	This restores all user configuration settings from a binary encrypted file on the USB root directory to the radio.

---

**Note:** 'Payload Encryption Key' and 'Key Encryption Key' parameters (see 'Security > Setup') are not saved to the configuration file. When a 'Restore from PC' or 'Restore from Radio USB' is used, these parameters will retain their existing values so are not changed by the operation of restoring the configuration file.

---

## File - Event History Log

## Action

Action	Option
Save to PC	<p>This saves the file with a filename of 'Info.tar.gz' to a binary encrypted file. This can then be saved from the Browser popup (example is Windows Internet Explorer 11). The file should be renamed to be able to identify the radio it was saved from.</p> <p>The 'gz' file is normally for sending back to 4RF Limited for analysis but can be opened with WinRar.</p>

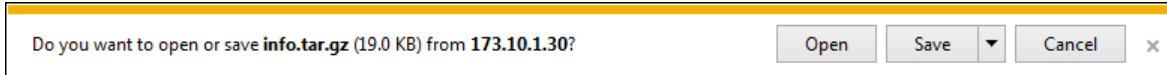

Save to Radio USB	<p>This saves the file with a filename of e.g. 'alarm_173.10.1.30_2014-11-10,15.54.14.txt' to a text file on the radio USB flash drive root directory.</p>
-------------------	--

### File - Configuration Script

#### Action

Action	Option
Load and Execute	<p>This loads and executes configuration script files.</p> <p>There are sample configuration script files on the product CD in a directory called 'Master Configuration'.</p> <p>The purpose of these files is to use as templates to create your own configuration scripts.</p> <p>Note: Be careful using this feature as incompatible configurations will change the radios settings and break radio connectivity.</p>

**Note:** Activating this function will over-write all existing configuration settings in the radio (except for the non-saved settings e.g. security passwords, licence keys etc) without any verification of the command setting in the radio. Precautions should be taken to prevent radio outages with incorrect radio configurations. The following process steps are recommended:

- a. Save the current radio configuration to a PC or USB before uploading the new configuration script file
- b. Upload the new configuration script file to the radio
- c. If for some reason the radio doesn't work as expected, the saved configuration file can be uploaded to the radio (roll back to previous configuration).

#### Retain IP Address

This parameter when enabled ensures that the radio IP address is not changed when the radio configuration settings are restored from a configuration file with a different IP radio address. It prevents the radio losing connectivity when the configuration settings are restored from a configuration file.

#### Revert Config if Connection Lost

When the Maintenance Files feature is used on remote radios from the base station, this parameter allows the configurations to be restored to the previous configuration if the connection is lost.

This must be set before executing the Configuration Settings / Configuration Script restore functions.

## Events

The Events menu contains the setup and management of the alarms, alarm events and traps.

### Events > Alarm Summary

There are two types of events that can be generated on the Aprisa SRi radio. These are:

#### 1. Alarm Events

Alarm Events are generated to indicate a problem on the radio.

#### 2. Informational Events

Informational Events are generated to provide information on key activities that are occurring on the radio. These events do not indicate an alarm on the radio and are used to provide information only.

See 'Alarm Types and Sources' on page 273 for a complete list of events.

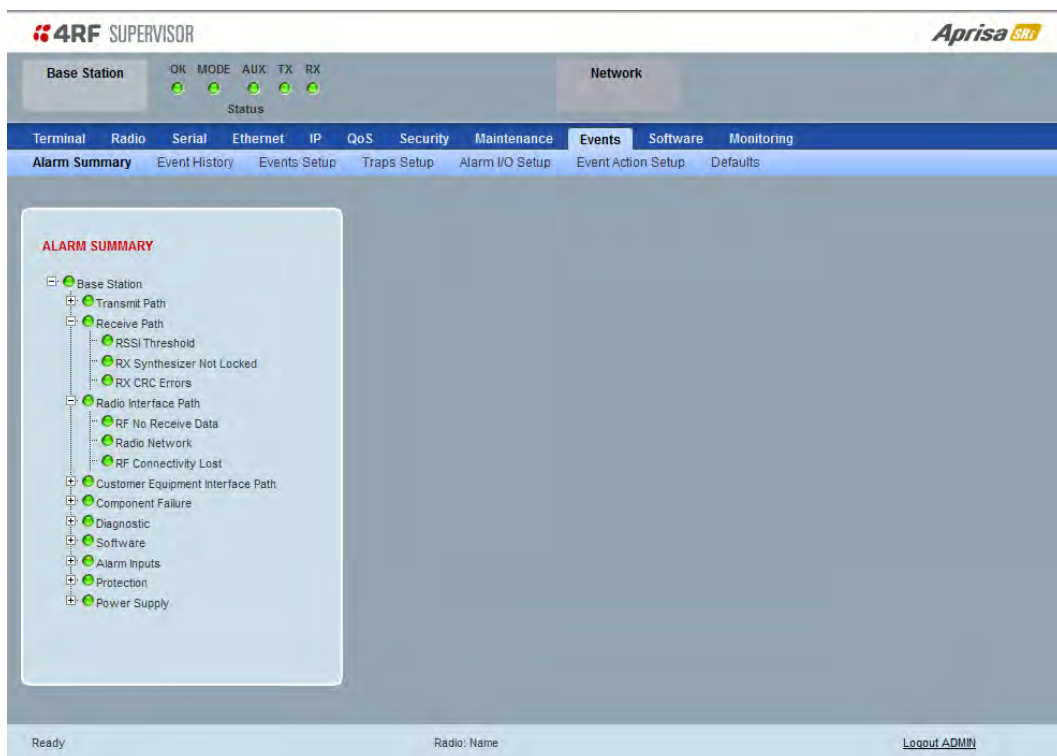

### ALARM SUMMARY

The Alarm Summary is a display tree that displays the current states of all radio alarms. The alarm states refresh automatically every 12 seconds.

LED Colour	Severity
Green	No alarm
Orange	Warning alarm
Red	Critical, major or minor alarm

Events > Event History

**4RF SUPERVISOR** **Aprisa SRi**

Base Station OK MODE AUX TX RX Network  
Status

Terminal Radio Serial Ethernet IP QoS Security Maintenance **Events** Software Monitoring

Alarm Summary **Event History** Events Setup Traps Setup Alarm I/O Setup Event Action Setup Defaults

**EVENT HISTORY**

Log ID	Date/time	Event ID	Description	State	Severity	Additional Information
24	01/01/2011 14:23:13	26	User Authentication Succeeded	inactive	information	SuperVisor, User admin, Local authentication OK, IP Addr 172.10.1.1
23	01/01/2011 14:20:32	72	User Session Logout	inactive	information	SuperVisor, User admin, IP Addr 172.10.1.1
22	01/01/2011 14:07:01	26	User Authentication Succeeded	inactive	information	SuperVisor, User admin, Local authentication OK, IP Addr 172.10.1.1
21	01/01/2011 14:06:26	55	Terminal Unit Information	inactive	information	Initial Frequency Adjust Values: Rx=0, Tx=0
20	01/01/2011 14:06:25	30	Software Start Up	inactive	information	User Reboot (CLI)
19	01/01/2011 14:05:20	26	User Authentication Succeeded	inactive	information	CLI, User admin, Local authentication OK
18	01/01/2011 14:05:13	27	User Authentication Failed	inactive	information	CLI, User debug clear 255 255, Local authentication failed
17	01/01/2011 14:04:40	55	Terminal Unit Information	inactive	information	Initial Frequency Adjust Values: Rx=0, Tx=0

Auto Refresh  Prev Next

Ready Radio: Name [Logout ADMIN](#)

**EVENT HISTORY**

The last 1500 events are stored in the radio. The complete event history list can be downloaded to a USB flash drive (see ‘File - Event History Log’ on page 195).

The Event History can display the last 50 events stored in the radio in blocks of 8 events.

The Next button will display the next page of 8 events and the Prev button will display the previous page of 8 events. Using these buttons will disable Auto Refresh to prevent data refresh and page navigation contention.

The last 50 events stored in the radio are also accessible via an SNMP command.

*Auto Refresh*

The Event History page selected will refresh automatically every 12 seconds if the Auto Refresh is ticked.



## Events &gt; Events Setup

ID	Name	Severity	Suppress	Lower Limit	Upper Limit	Units	Duration	Units
1	PA Current	critical	none					
61	PA Driver Current	critical	none					
62	PA Stability	warning	none					
2	TX AGC	critical	none					
60	TX Forward Power	warning	none					
3	TX Reverse Power	warning	none					
4	Temperature Threshold	warning	none	-30.0	75.0	Celsius		
5	TX Synthesizer Not Locked	critical	none					

**EVENTS SETUP**

Alarm event parameters can be configured for all alarm events (see ‘Alarm Events’ on page 274).

All active alarms for configured alarm events will be displayed on the Monitoring pages (see ‘Monitoring’ on page 227).

**Severity**

The Severity parameter sets the alarm severity.

Severity	Function
Critical	The Critical severity level indicates that a service affecting condition has occurred and an immediate corrective action is required. Such a severity can be reported, for example, when a managed object becomes totally out of service and its capability must be restored.
Major	The Major severity level indicates that a service affecting condition has developed and an urgent corrective action is required. Such a severity can be reported, for example, when there is a severe degradation in the capability of the managed object and its full capability must be restored.
Minor	The Minor severity level indicates the existence of a non-service affecting fault condition and that corrective action should be taken in order to prevent a more serious (for example, service affecting) fault. Such a severity can be reported, for example, when the detected alarm condition is not currently degrading the capacity of the managed object.
Warning	The Warning severity level indicates the detection of a potential or impending service affecting fault, before any significant effects have been felt. Action should be taken to further diagnose (if necessary) and correct the problem in order to prevent it from becoming a more serious service affecting fault.
Information	No problem indicated - purely information

### *Suppress*

This parameter determines if the action taken by an alarm.

Option	Function
None	Alarm triggers an event trap and is logged in the radio
Traps	Alarm is logged in the radio but does not trigger an event trap
Traps and Log	Alarm neither triggers an event trap nor is logged in the radio

### *Lower Limit / Upper Limit*

Threshold alarm events have lower and upper limit settings. The alarm is activated if the current reading is outside the limits.

#### Example: 9 RX CRC Errors

The Upper Limit is set to 0.7 and the Duration is set to 5 seconds.

If in any 5 second period, the total number of errored packets divided by the total number of received packets exceeds 0.7, the alarm will activate.

### *Units (1)*

The Units parameter shows the unit for the Lower Limit and Upper Limit parameters.

### Duration

This parameter determines the period to wait before an alarm is raised if no data is received.

### *Units (2)*

This parameter shows the unit for the Duration parameters.

The Next button will display the next page of 8 alarm events and the Prev button will display the previous page of 8 alarm events.

## Events &gt; Traps Setup

Destination Address	Port	Community String	Notification Mode	Notification Type	Timeout (seconds)	Maximum Retries	Enabled
0.0.0.0	162	public	Event Recorded	Standard Trap	5	3	<input type="checkbox"/>
0.0.0.0	162	public	Event Recorded	Standard Trap	5	3	<input type="checkbox"/>
0.0.0.0	162	public	Event Recorded	Standard Trap	5	3	<input type="checkbox"/>
0.0.0.0	162	public	Event Recorded	Standard Trap	5	3	<input type="checkbox"/>
0.0.0.0	162	public	Event Recorded	Standard Trap	5	3	<input type="checkbox"/>

**TRAPS SETUP**

All events can generate SNMP traps. The types of traps that are supported are defined in the ‘Notification Mode’.

*Destination Address*

This parameter sets the IP address of the server running the SNMP manager.

*Port*

This parameter sets the port number the server running the SNMP manager.

*Community String*

This parameter sets the community string which is sent with the IP address for security. The default community string is ‘public’.

*Notification Mode*

This parameter sets when an event related trap is sent:

Option	Function
None	No event related traps are sent.
Event Recorded	When an event is recorded in the event history log, a trap is sent.
Event Updated	When an event is updated in the event history log, a trap is sent.
All Events	When an event is recorded or updated in the event history log, a trap is sent.

### *Notification Type*

This parameter sets the type of event notification:

Option	Function
Standard Trap	Provides a standard SNMP trap event
Inform Request	Provides a SNMP v2 Inform Request trap event including trap retry and acknowledgement

Notification Type set to Inform Request:

### *Timeout (second)*

This parameter sets the time interval to wait for an acknowledgement before sending another retry.

### *Maximum Retries*

This parameter sets the maximum number of retries to send the event without acknowledgement before it gives up.

### *Enabled*

This parameter determines if the entry is used.

## Events &gt; Alarm I/O Setup

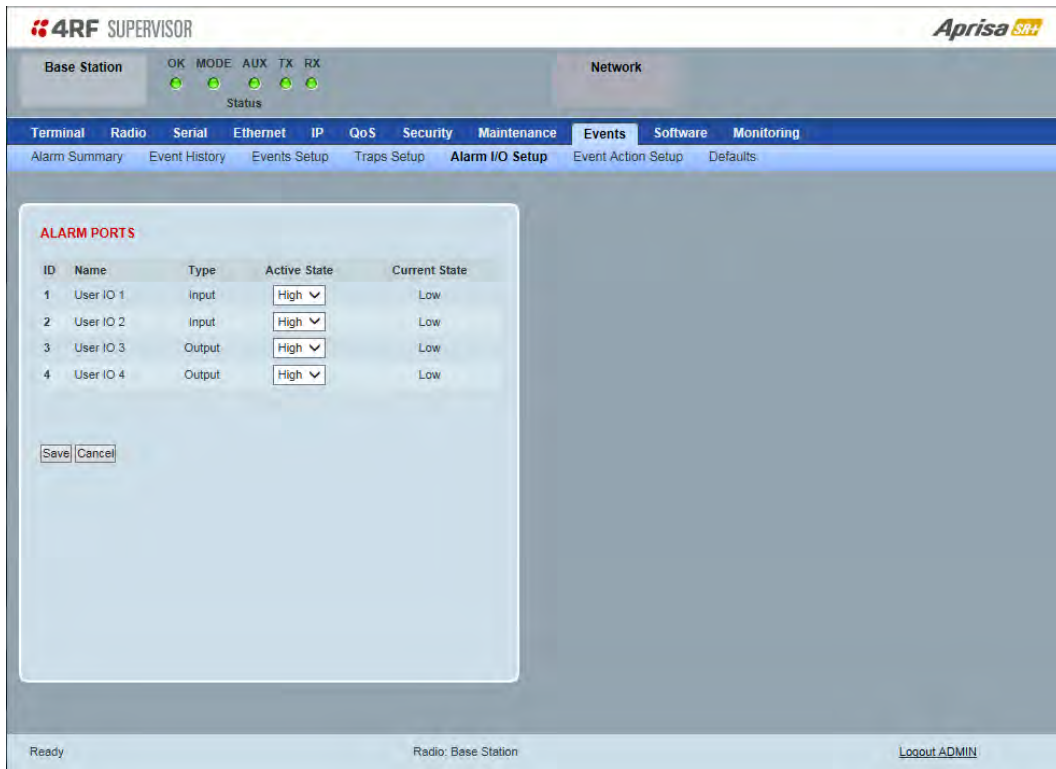
**ALARM PORTS**

This page provides control of the two hardware alarm inputs and two hardware alarm outputs provided on the alarm connector.

The alarm inputs are used to transport alarms to the other radios in the network. The alarm outputs are used to receive alarms from other radios in the network.

*Name*

The alarm IO number.

*Type*

The Type shows if the alarm is an input or output.

### *Active State*

The Active State parameter sets the alarm state when the alarm is active.

#### Alarm Input

Option	Function
Low	The alarm is active low i.e. a ground contact on the port will cause an active alarm state
High	The alarm is active high i.e. an open contact on the port will cause an active alarm state

#### Alarm Output

Option	Function
Low	The alarm is active low i.e. the active alarm state will generate a ground contact output
High	The alarm is active high i.e. the active alarm state will generate a open contact output

### *Current State*

The Current State shows the current state of the alarm.

## Events &gt; Event Action Setup

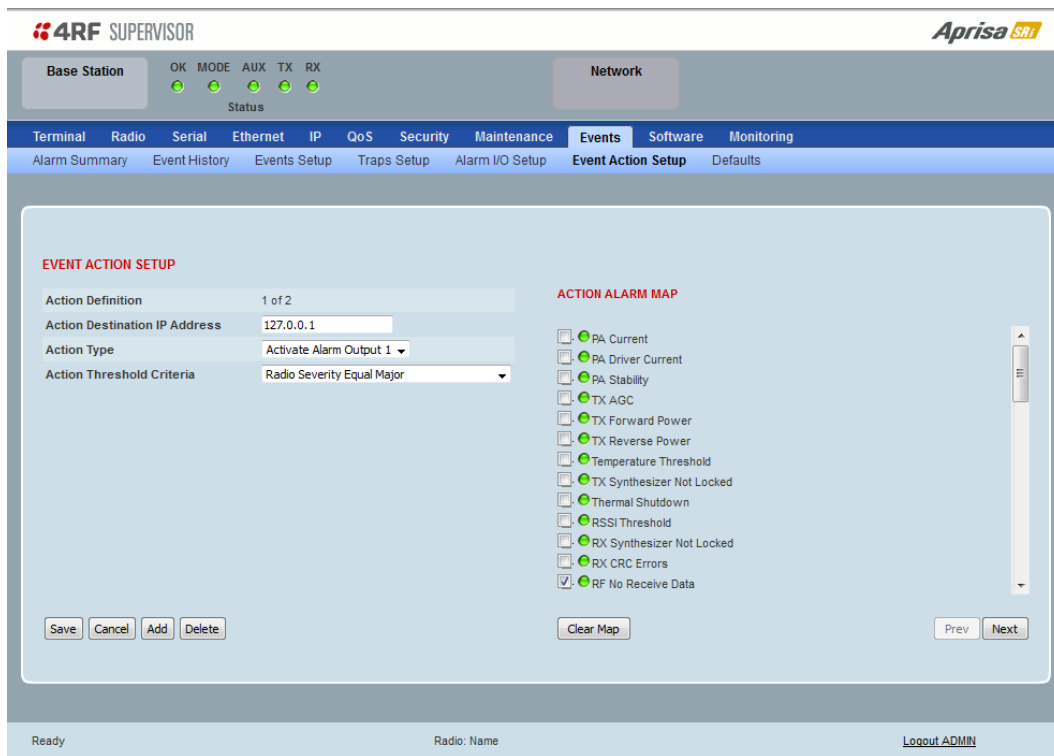

## EVENT ACTION SETUP

This page provides control of the mapping of events to specific actions. Specific alarm events can setup to trigger outputs.

*Action Definition*

This parameter shows the number of the event action setup and the maximum number of setups stored.

*Action Destination IP Address*

This parameter sets the IP address of the radio that will output the action type.

*Action Type*

This parameter sets the action type that will be activated on the radio.

Option	Function
None	This action setup does not activate any alarm output
Activate Alarm Output 1	This action setup activates alarm output 1
Activate Alarm Output 2	This action setup activates alarm output 2

### Action Threshold Criteria

This parameter sets the radio event that will trigger the action output.

Option	Function
None	No action output.
Radio Severity Equal Critical	Activates the action output when a radio alarm is critical alarm
Radio Severity Equal Major	Activates the action output when a radio alarm is a major alarm
Radio Severity Equal Minor	Activates the action output when a radio alarm is minor alarm
Radio Severity Equal Warning	Activates the action output when a radio alarm is a warning alarm
Radio Severity Equal Cleared	Activates the action output when a radio alarm is cleared
Radio Severity Equal or Worse than Major	Activates the action output when a radio alarm is a major alarm or a critical alarm
Radio Severity Equal or Worse than Minor	Activates the action output when a radio alarm is a minor alarm, a major alarm or a critical alarm
Radio Severity Equal or Worse than Warning	Activates the action output when a radio alarm is a warning, a major alarm, a minor alarm or a critical alarm

### Controls

The Save button saves the current event action setup.

The Cancel button cancels the new event action setup.

The Add button adds a new event action setup.

The Delete button deletes the current event action setup.

The Clear Map button clears all alarm selections on the current setup.

#### To add an event action setup:

1. Click on the Add button.
2. Enter the Action Destination IP Address. This is the IP address of the radio that will output the action type.
3. Select the Action Type from the list.
4. Select the Action Threshold Criteria from the list.
5. Tick the alarms required for the event action setup from the Action Alarm Map. You can clear all alarm selections with the Clear Map button.
6. Click on Save.



## Events &gt; Defaults

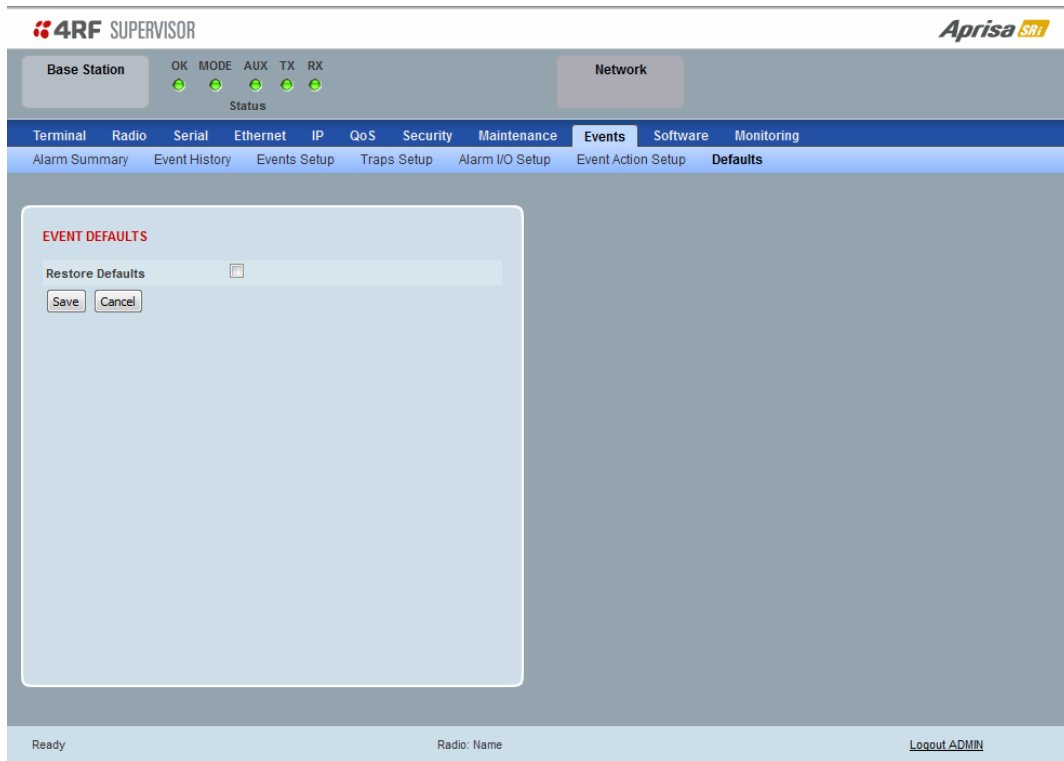

## EVENT DEFAULTS

*Restore Defaults*

This parameter when activated restores all previously configured event parameters using 'Events > Events Setup' to the factory default settings.

## Software

The Software menu contains the setup and management of the system software including network software distribution and activation. The distribution of the system software to the remote radios is encrypted by the AES session key over-the-air.

### Single Radio Software Upgrade

The radio software can be upgraded on a single Aprisa SRi radio (see ‘Single Radio Software Upgrade’ on page 268). This process would only be used if the radio was a replacement or a new station in an existing network.

### Network Software Upgrade

The radio software can be upgraded on an entire Aprisa SRi radio network remotely over the radio link (see ‘Network Software Upgrade’ on page 266). This process involves following steps:

1. Transfer the new software to base station with ‘Software > File Transfer’
2. Distribute the new software to all remote stations with ‘Software > Remote Distribution’
3. Activate of the new software on remote stations with ‘Software > Remote Activation’.
4. Finally, activate the new software on the base station radio with ‘Software > Manager’. Note: activating the software will reboot the radio.

## Software > Summary

This page provides a summary of the software versions installed on the radio, the setup options and the status of the File Transfer.

The screenshot shows the '4RF SUPERVISOR' interface with the 'Aprisa SRi' logo. The top navigation bar includes 'Base Station' (with OK, MODE, AUX, TX, RX status indicators) and 'Network'. The main menu has 'Terminal', 'Radio', 'Serial', 'Ethernet', 'IP', 'QoS', 'Security', 'Maintenance', 'Events', 'Software', and 'Monitoring'. The 'Software' sub-menu includes 'Summary', 'Setup', 'File Transfer', 'Manager', 'Remote Distribution', and 'Remote Activation'. The 'Summary' page is divided into two main sections: 'SOFTWARE VERSIONS' and 'USB AUTOMATIC UPGRADE'. The 'SOFTWARE VERSIONS' section shows a table with three rows: 'Current Version' (1.0.0), 'Previous Version' (Unknown), and 'Software Pack Version' (1.0.0). The 'USB AUTOMATIC UPGRADE' section has a 'USB Boot Cycle Upgrade' button labeled 'Load And Activate'. Below this is the 'FILE TRANSFER' section, which shows 'Transfer Activity', 'Method' (Unknown), 'Filename', and 'Transfer Result'. At the bottom of the interface, there is a status bar with 'Ready', 'Radio: Name', and a 'Logout ADMIN' link.

### SOFTWARE VERSIONS

#### *Current Version*

This parameter displays the software version running on the radio.

#### *Previous Version*

This parameter displays the software version that was running on the radio prior to the current software being activated.

#### *Software Pack Version*

On the base station, this parameter displays the software version available for distribution to all radios in the network.

On the all stations, this parameter displays the software version ready for activation.

### USB AUTOMATIC UPGRADE

#### *USB Boot Upgrade*

This parameter shows the type of USB Boot upgrade defined in 'Software Setup > USB Boot Upgrade' on page 211.

## FILE TRANSFER

### *Transfer Activity*

This parameter shows the status of the transfer, 'Idle', 'In Progress' or 'Completed'.

### *Method*

This parameter shows the file transfer method. When the software distribution is in progress, this parameter will change to 'Over the Air' (from xx.xx.xx.xx) to show that the interface is busy and the transfer is in progress.

### *File*

This parameter shows the software file source.

### *Transfer Result*

This parameter shows the progress of the transfer.

## Software &gt; Setup

This page provides the setup of the USB flash drive containing a Software Pack.

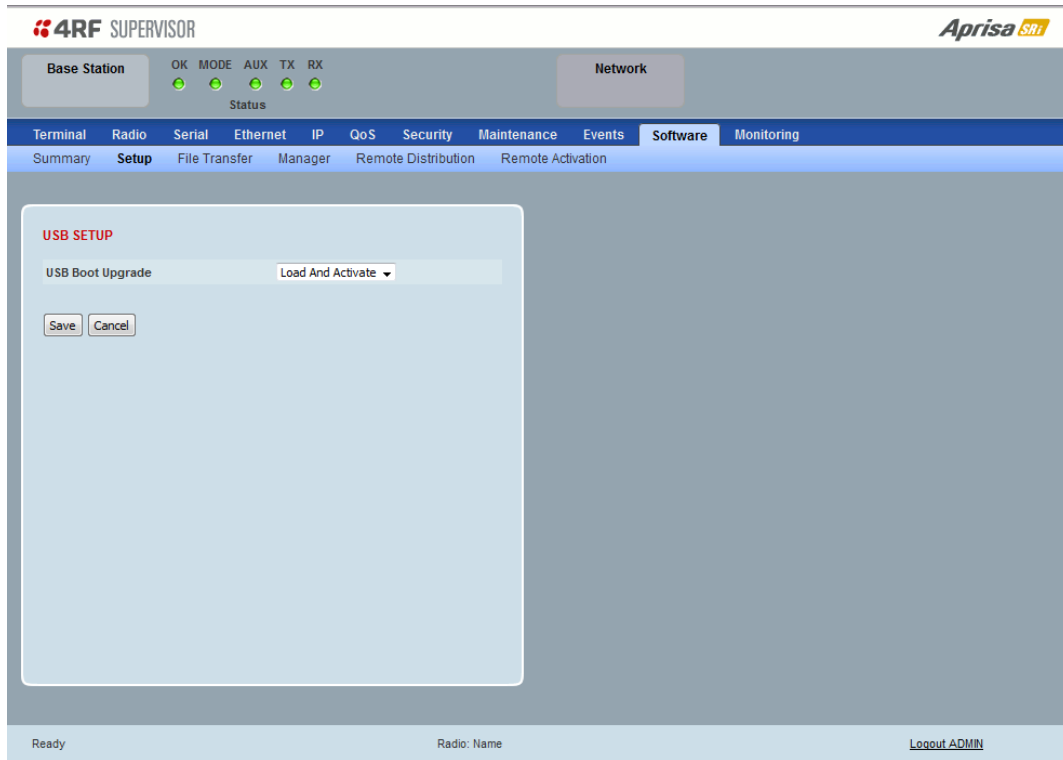

## USB SETUP

*USB Boot Upgrade*

This parameter determines the action taken when the radio power cycles and finds a USB flash drive in the Host port. The default setting is ‘Load and Activate’.

Option	Function
Load and Activate	New software will be uploaded from a USB flash drive in to the Aprisa SRi when the radio is power cycled and activated automatically.
Load Only	New software will be uploaded from a USB flash drive in to the Aprisa SRi when the radio is power cycled. The software will need to be manually activated (see ‘Software > Manager’ on page 216).
Disabled	Software will not be uploaded from a USB flash drive into the Aprisa SRi when the radio is power cycled.

---

**Note:** This parameter must be set to ‘Disabled’ if the ‘File Transfer and Activate’ method of upgrade is used. This ‘Disabled’ setting prevents the radio from attempting another software upload when the radio boots (which it does automatically after activation).

---

## Software > File Transfer

This page provides the mechanism to transfer new software from a file source into the radio.

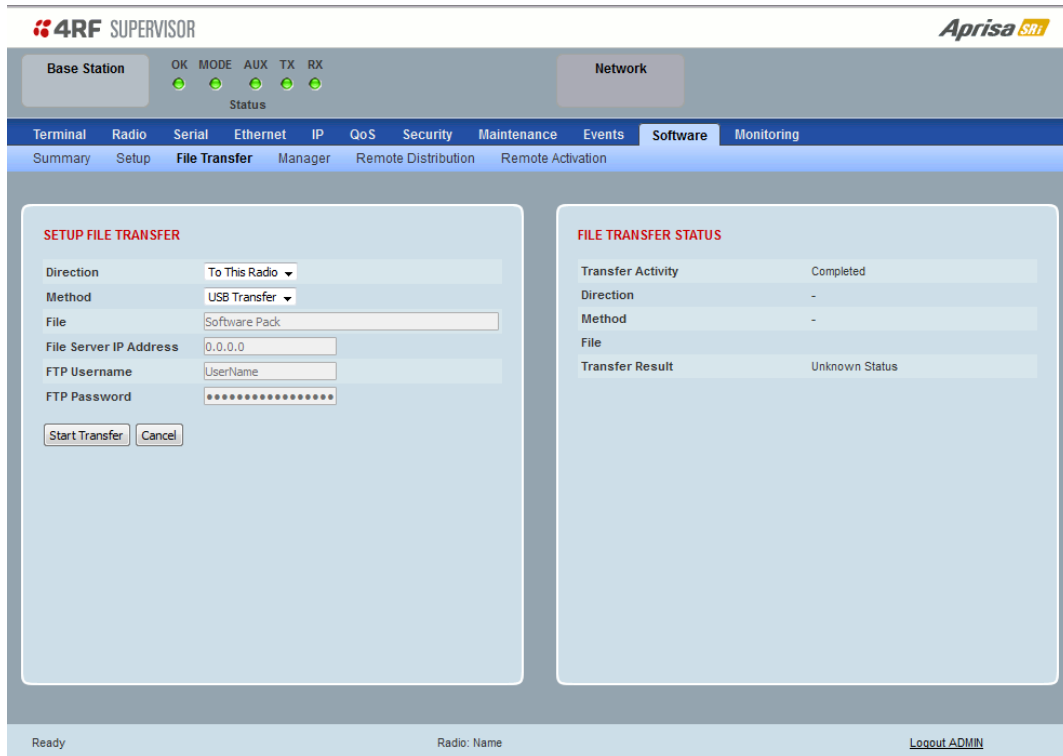

### SETUP FILE TRANSFER

#### *Direction*

This parameter sets the direction of file transfer. In this software version, the only choice is 'To the Radio'.

#### *Method*

This parameter sets the method of file transfer.

Option	Function
USB Transfer	Transfers the software from the USB flash drive to the radio.
FTP	Transfers the software from an FTP server to the radio.
HTTP / HTTPS	Transfers the software directly from a PC software pack file to the radio.

#### *File*

This parameter shows the software file source.

#### *FTP Username*

This parameter sets the Username to access the FTP server.

#### *FTP Password*

This parameter sets the Password to access the FTP server.

## FILE TRANSFER STATUS

### *Transfer Activity*

This parameter shows the status of the transfer, 'Idle', 'In Progress' or 'Completed'.

### *Direction*

This parameter shows the direction of file transfer. In this software version, the only choice is 'To The Radio'.

### *Method*

This parameter shows the file transfer method.

### *File*

This parameter shows the software file source.

### *Transfer Result*

This parameter shows the progress of the transfer:

Transfer Result	Function
Starting Transfer	The transfer has started but no data has transferred.
In Progress (x %)	The transfer has started and has transferred x % of the data.
Successful	The transfer has finished successfully.
File Error	<p>The transfer has failed.</p> <p>Possible causes of failure are:</p> <ul style="list-style-type: none"> <li>• Is the source file available e.g. USB flash drive plugged in</li> <li>• Does the file source contain the Aprisa SRi software release files;</li> </ul> 

To transfer software into the Aprisa SRi radio:

#### USB Transfer Method

1. Unzip the software release files in to the root directory of a USB flash drive.
2. Insert the USB flash drive into the host port .
3. Click on 'Start Transfer'.

FILE TRANSFER STATUS	
Transfer Activity	In Progress
Direction	To This Radio
Method	USB Transfer
File	Software Pack
Transfer Result	In Progress ( 30% )

4. When the transfer is completed, remove the USB flash drive from the host port. If the SuperVisor 'USB Boot Upgrade' setting is set to 'Disabled' (see 'USB Boot Upgrade' on page 211), the USB flash drive doesn't need to be removed as the radio won't try to load from it.

Go to Supervisor > Software > Manager and activate the Software Pack (see 'Software > Manager' on page 216). The radio will reboot automatically.

If the file transfer fails, check the Event History page (see 'Events > Event History' on page 198) for more details of the transfer.

---

Note: Some brands of USB flash drives may not work with 4RF radios.

---

#### FTP Method

1. Unzip the software release files in to a temporary directory.
2. Open the FTP server and point it to the temporary directory.
3. Enter the FTP server IP address, Username and password into SuperVisor.
4. Click on 'Start Transfer'.

FILE TRANSFER STATUS	
Transfer Activity	In Progress
Direction	To This Radio
Method	FTP (172.17.10.11)
File	Software Pack
Transfer Result	In Progress ( 1% )

Go to Supervisor > Software > Manager and activate the Software Pack (see 'Software > Manager' on page 216). The radio will reboot automatically.

If the file transfer fails, check the Event History page (see 'Events > Event History' on page 198) for more details of the transfer.



### HTTP / HTTPS Method

1. Unzip the software release files in to a temporary directory.
2. Click on ‘Start Transfer’.
3. Browse to the \*.swpack file in the temporary directory and open the file.

FILE TRANSFER STATUS	
Transfer Activity	In Progress
Direction	To This Radio
Method	HTTPS
File	Software Pack
Transfer Result	In Progress ( 5% )

Go to Supervisor > Software > Manager and activate the Software Pack (see ‘Software > Manager’ on page 216). The radio will reboot automatically.

If the file transfer fails, check the Event History page (see ‘Events > Event History’ on page 198) for more details of the transfer.

## Software > Manager

This page summarises and manages the software versions available in the radio.

The manager is predominantly used to activate new software on single radios. Network activation is performed with 'Software > Remote Activation'.

Both the previous software (if available) and Software Pack versions can be activated on the radio from this page.

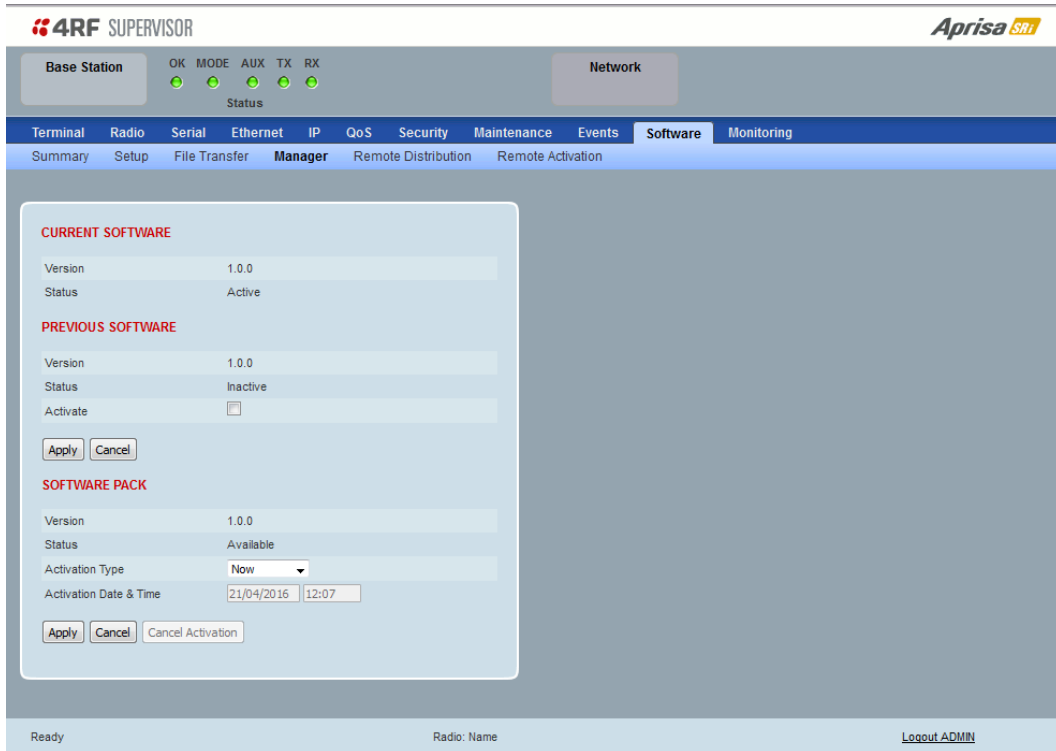

**4RF SUPERVISOR** **Aprisa SRI**

Base Station OK MODE AUX TX RX  
Status

Network

Terminal Radio Serial Ethernet IP QoS Security Maintenance Events **Software** Monitoring

Summary Setup File Transfer **Manager** Remote Distribution Remote Activation

**CURRENT SOFTWARE**

Version 1.0.0  
Status Active

**PREVIOUS SOFTWARE**

Version 1.0.0  
Status Inactive  
Activate

Apply Cancel

**SOFTWARE PACK**

Version 1.0.0  
Status Available  
Activation Type Now  
Activation Date & Time 21/04/2016 12:07

Apply Cancel Cancel Activation

Ready Radio: Name [Logout ADMIN](#)

### CURRENT SOFTWARE

#### *Version*

This parameter displays the software version running on the radio.

#### *Status*

This parameter displays the status of the software version running on the radio (always active).

## PREVIOUS SOFTWARE

### *Version*

This parameter displays the software version that was running on the radio prior to the current software being activated.

### *Status*

This parameter displays the status of the software version that was running on the radio prior to the current software being activated.

Option	Function
Active	The software is operating the radio.
Inactive	The software is not operating the radio but could be re-activated if required.

### *Activate*

This parameter activates the previous software version (restores to previous version).

The Aprisa SRi will automatically reboot after activation.

## SOFTWARE PACK

### *Version*

This parameter displays the software pack version available for distribution on base station and activate on all stations.

### *Status*

This parameter displays the status of the software pack version.

Option	Function
Available	On the base station, the software pack is available for distribution. On all stations, the software pack is available for activation.
Activating	The software pack is activating in the radio.
Unavailable	There is no software pack loaded into the radio.

### *Activate*

This parameter activates the software pack.

The Aprisa SRi will automatically reboot after activation.

### *Activation Type*

This parameter sets when the software pack activation will occur.

Option	Function
Now	Activates the software pack now.
Date & Time	Activates the software pack at the Date & Time set in the following parameter.

### Activation Date & Time

This parameter sets the Date & Time when the software pack activation will occur.

This setting can be any future date and 24 hour time.

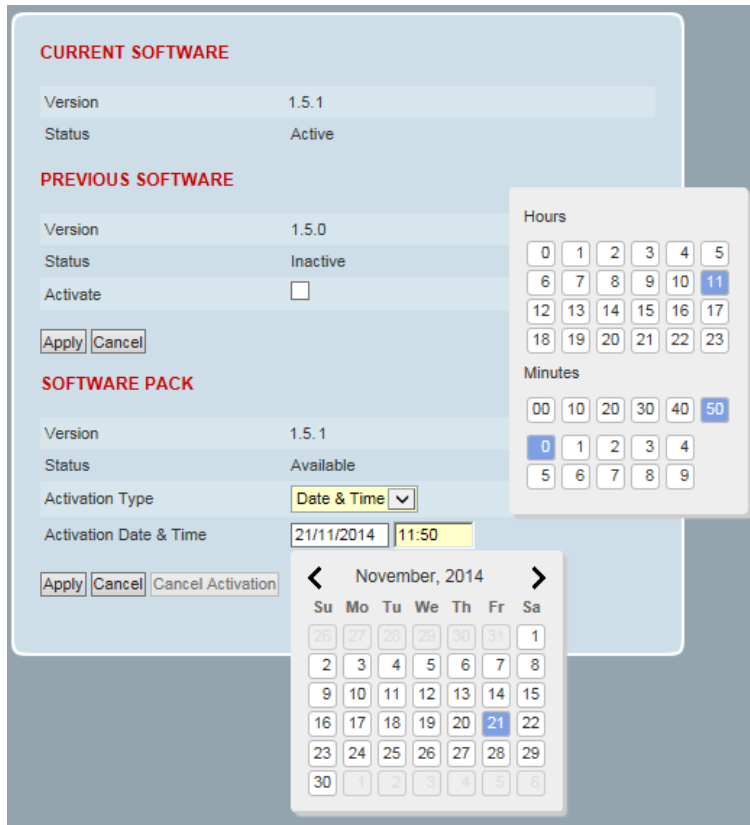

If the network base station radio date / time is not synchronized, you will get the following popup:

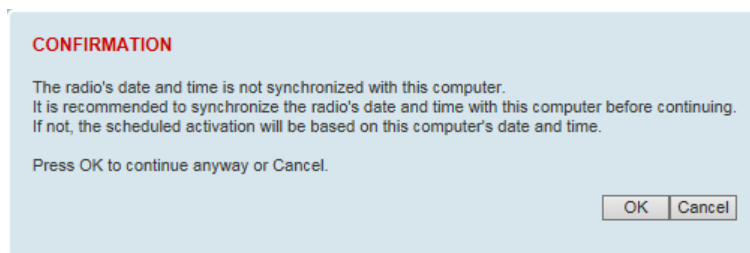

You can manually enter the base station radio date / time or use the Date And Time Synchronization from a SNTP server feature (see 'Terminal > Date / Time' on page 84).

**To activate a software version:**

1. Tick the software version required to be activated (previous software or software pack).
2. Click 'Apply'.

The page will display a Status of 'Activating'.

Once started, activation cannot be cancelled.

When the activation is completed, the radio will reboot. This will cause the current SuperVisor session to expire.

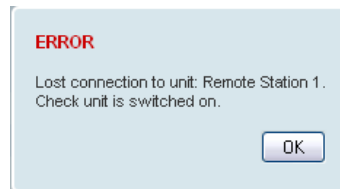

3. Login to SuperVisor to check the result.

## Software > Remote Distribution

This page provides the mechanism to distribute software to all remote stations into the Aprisa SRi network (network) and then activate it.

The Software Pack that was loaded into the base station with the file transfer process (see ‘Software > File Transfer’ on page 212) can be distributed via the radio link to all remote stations.

This page is used to manage the distribution of that software pack to all remote radios on the network.

This page is only available when the radio is configured as a Base Station.

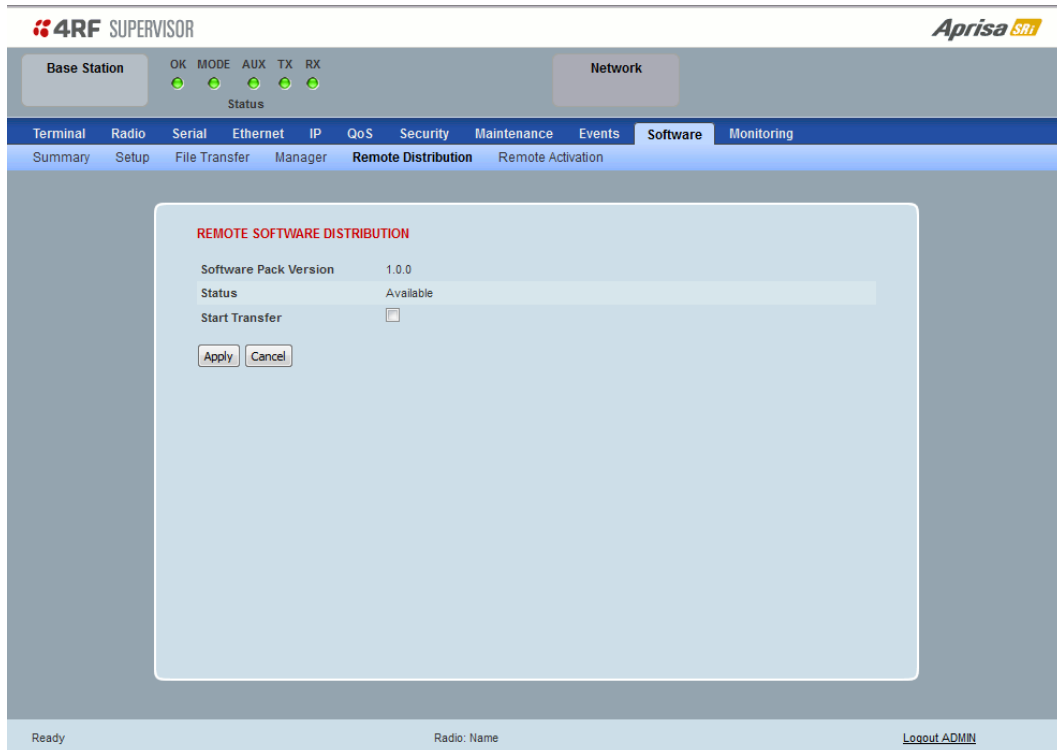

### REMOTE SOFTWARE DISTRIBUTION

#### *Software Pack Version*

This parameter displays the software pack version available for distribution on base station and activate on all stations.

#### *Status*

This parameter displays the status of the software pack version.

If a Software Pack is not available, the status will display ‘Unavailable’ and the software distribution mechanism will not work.

### Start Transfer

This parameter when activated distributes (broadcasts) the new Software Pack to all remote stations in the network.

---

**Note:** The distribution of software to remote stations does not stop customer traffic from being transferred. However, due to the volume of traffic, the software distribution process may affect customer traffic.

Software distribution traffic is classified as ‘management traffic’ but does not use the Ethernet management priority setting. Software distribution traffic priority has a fixed priority setting of ‘very low’.

---

### To distribute software to remote stations:

This process assumes that a Software Pack has been loaded into the base station with the file transfer process (see ‘Software > File Transfer’ on page 212).

1. To ensure that the Network Table is up to date, it is recommended running the node discover function (see ‘Discover Nodes’ on page 193).
2. Click on ‘Start Transfer’.

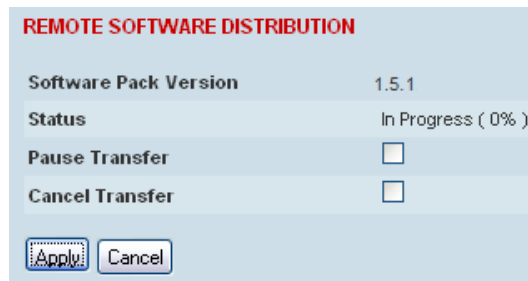

REMOTE SOFTWARE DISTRIBUTION	
Software Pack Version	1.5.1
Status	In Progress ( 0% )
Pause Transfer	<input type="checkbox"/>
Cancel Transfer	<input type="checkbox"/>
<input type="button" value="Apply"/> <input type="button" value="Cancel"/>	

---

**Note:** This process could take anywhere between 40 minutes and several hours depending on channel size, Ethernet Management Priority setting and the amount of customer traffic on the network.

---

3. When the distribution is completed, activate the software with the Remote Software Activation.

### Pause Transfer

This parameter when activated, pauses the distribution process and shows the distribution status. The distribution process will continue from where it was paused with Resume Transfer.

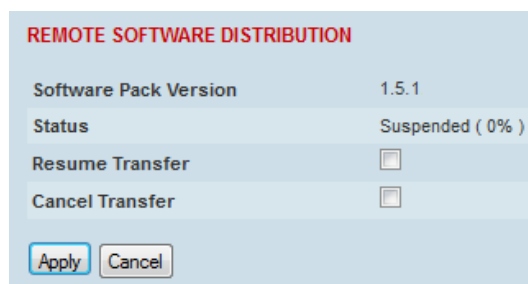

REMOTE SOFTWARE DISTRIBUTION	
Software Pack Version	1.5.1
Status	Suspended ( 0% )
Resume Transfer	<input type="checkbox"/>
Cancel Transfer	<input type="checkbox"/>
<input type="button" value="Apply"/> <input type="button" value="Cancel"/>	

### Cancel Transfer

This parameter when activated, cancels the distribution process immediately.

During the distribution process, it is possible to navigate away from this page and come back to it to check progress. The SuperVisor session will not timeout.

## Software > Remote Activation

This page provides the mechanism to activate software on all remote stations.

The Software Pack was loaded into the base station with the file transfer process (see ‘Software > File Transfer’ on page 212) and was distributed via the radio link to all remote stations.

This page is used to manage the activation of that software pack on all remote radios on the network.

This page is only available when the radio is configured as a Base Station.

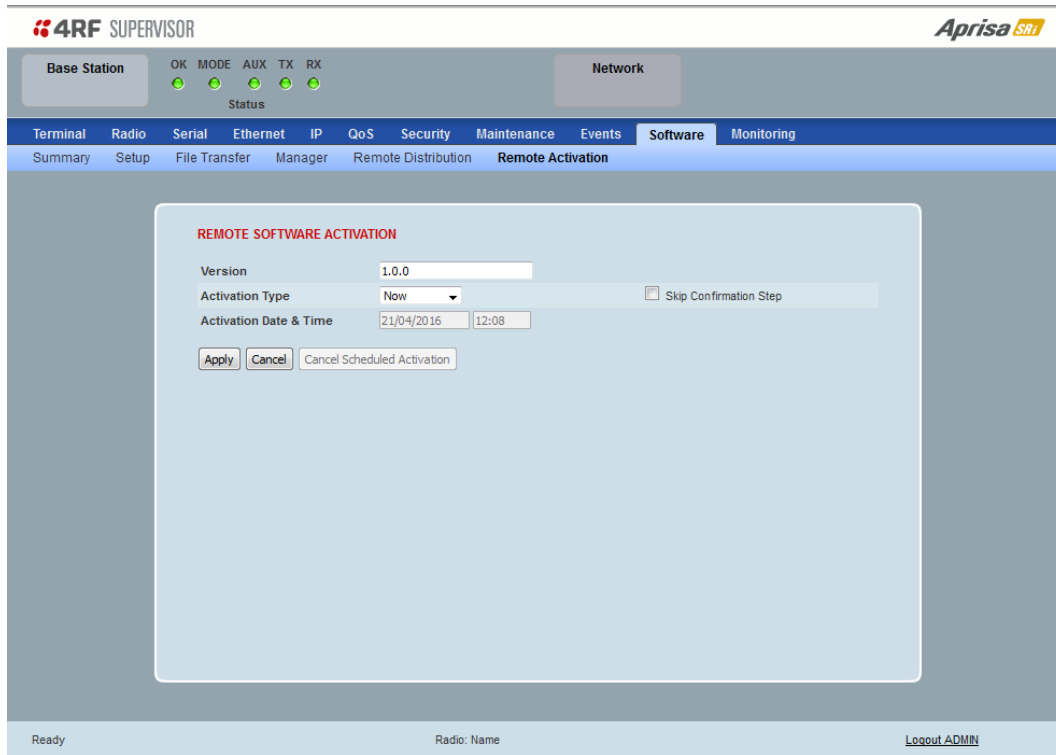

### REMOTE SOFTWARE ACTIVATION

When the software pack version has been distributed to all the remote stations, the software is then activated in all the remote stations with this command. If successful, then activate the software pack in the base station to complete the network upgrade.

#### Version

This parameter displays the software version for activation. The default version is the software pack version but any valid software version can be entered in the format ‘n.n.n’.

#### Activation Type

This parameter sets when the software pack activation will occur.

Option	Function
Now	Activates the software pack now.
Date & Time	Activates the software pack at the Date & Time set in the following parameter.



### Activation Date & Time

This parameter sets the Date & Time when the software pack activation will occur.

This setting can be any future date and 24 hour time.

### Skip Confirmation Step

This parameter when enabled skips the confirmation step during the activation process.

Normally, the confirmation step will require use intervention to accept the confirmation which will halt the activation process. Skipping the confirmation will enable the activation process to continue without use intervention.

### To activate software in remote stations:

This process assumes that a Software Pack has been loaded into the base station with the file transfer process (see 'Software > File Transfer' on page 212) and distributed to all remote radios in the network.

---

**Note:** Do not navigate SuperVisor away from this page during the activation process (SuperVisor can lose PC focus).

---

1. Enter the Software Pack version (if different from displayed version).

**REMOTE SOFTWARE ACTIVATION**

Version

Activation Type   Skip Confirmation Step

Activation Date & Time

---

Remote Radios Polled For Partners	1 of 1	Completed
Remote Radios Polled For New Version	1 of 1	Completed
Remote Radios Activated	0 of 0	Cancelled
Remote Radios On New Version	0 of 0	Cancelled

2. Select the Activation type.
3. Click Apply.

The remote stations will be polled to determine which radios require activation:

Result	Function (X of Y)
Remote Radios Polled for New Version	X is the number of radios polled to determine the number of radios that contain the new software version. Y is the number of remote radios registered with the base station.
Remote Radios Activated	X is the number of radios that contain the new software version and have been activated. Y is the number of radios that contain the new software version and can be activated.
Remote Radios On New Version	X is the number of radios that has been successfully activated and now running the new version of software. Y is the number of radios that the activation command was executed on.  <b>Note:</b> When upgrading from software version 1.2.5 to 1.2.6 or later, communication to all remote radios will be lost due to a MAC protocol change. This will prevent this function from working correctly. In this case, activate the new software on the base station and run the 'Maintenance > Advanced' Discover Nodes function on page 192.

When the activation is ready to start:

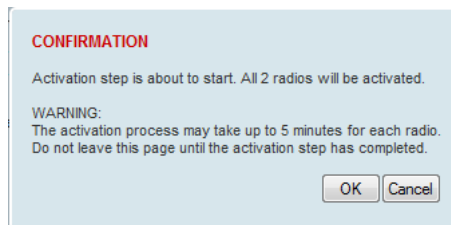

- Click on 'OK' to start the activation process or Cancel to quit.

The page will display the progress of the activation.

**REMOTE SOFTWARE ACTIVATION**

Version

---

Remote Radios Polled For Partners	4 of 4	Completed
Remote Radios Polled For New Version	0 of 4	Completed
Remote Radios Activated	0 of 0	Cancelled
Remote Radios On New Version	0 of 0	Cancelled

---

**REMOTE ACTIVATION EXCEPTIONS**

Name	IP Address	Version	Exception
Protected Remote Station	172.17.70.2	1.5.1	Software Version not on the radio (Step 2)
Remote125	172.17.70.125	1.5.1	Software Version not on the radio (Step 2)
Protected Remote Station	172.17.70.1	1.5.1	Software Version not on the radio (Step 2)

The example shows that during the activation process there were exceptions that may need to be investigated.

When all the remote radios have been activated, the base station radio must now be activated with (see 'Software > Manager' on page 216).

**INFORMATION**

All remotes successfully activated.  
Please install and activate software version 1.5.1 on the base station.

4. Click on 'OK' to start the activation on the base station.

### Activation Type

This parameter sets when the remote software activation will occur.

Option	Function
Now	Activates the remote software now.
Date & Time	Activates the remote software at the Date & Time set in the following parameter.

### Skip Confirmation Step

This parameter when enabled skips the confirmation step during the activation process.

Normally, the confirmation step will require user intervention to accept the confirmation which will halt the activation process. Skipping the confirmation will enable the activation process to continue without user intervention.

### Activation Date & Time

This parameter sets the Date & Time when the remote software activation will occur.

This setting can be any future date and 24 hour time.

When the date and time is set, the remotes will be polled to setup the scheduled activation date and time.

If the network base station radio date / time is not synchronized, you will get the following popup:

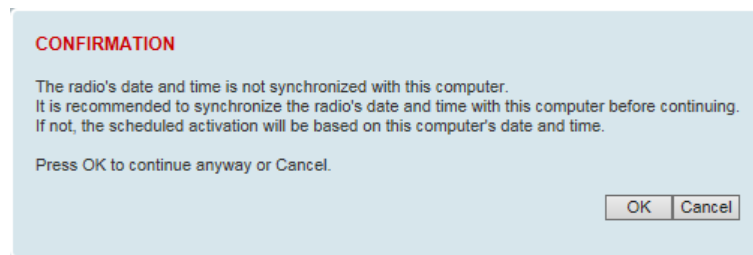

You can manually enter the base station radio date / time or use the Date And Time Synchronization from a SNTP server feature (see 'Terminal > Date / Time' on page 84).

## Monitoring

The Terminal, Serial, Ethernet, Radio and User Selected Monitored Parameter results have history log views for both Quarter Hourly and Daily.

Monitored parameter data is accumulated into 2 sets:

- 15 minutes of data, for 96 readings for the last 24 hours
- 24 hours of data, for 31 readings for the last 31 days.

### Monitoring > Terminal

This page displays the current radio internal and external input source radio power supply voltage diagnostic parameters.

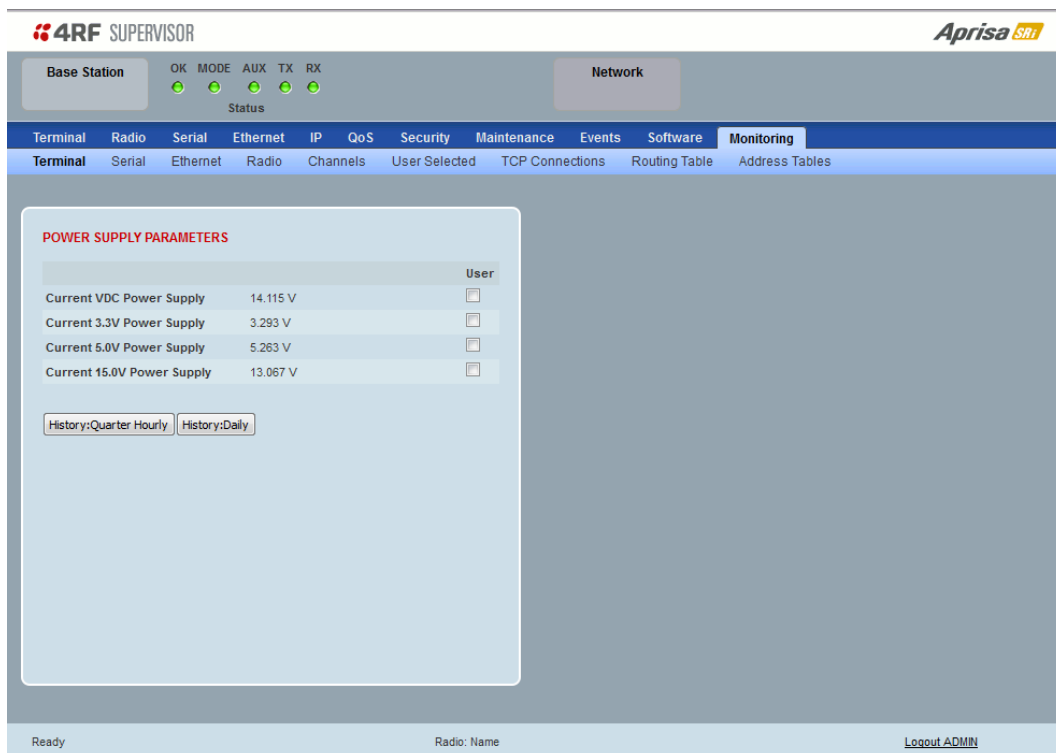

### POWER SUPPLY PARAMETERS

Monitored Parameter	Function	Normal Operating Limits
Current VDC Power Supply	Parameter to show the current power supply input voltage	10 to 30 VDC
Current 3.3 Volts Power Supply	Parameter to show the current 3.3 volt power rail voltage	3.1 to 3.5 VDC
Current 5.0 Volts Power Supply	Parameter to show the current that the current 5.0 volt power rail voltage	4.7 to 5.5 VDC
Current 7.2 Volts Power Supply	Parameter to show the current that the current 7.2 volt power rail voltage	6.9 to 7.5 VDC
Current 15 Volts Power Supply	Parameter to show the current that the current 15 volt power rail voltage. The 15 volt power supply is used to power the transmitter driver and power amplifier.	12.7 to 13.5 VDC

### Controls

The History Quarter Hourly button presents a log of results every quarter of an hour.

Power Supply	20/04/16 11:15	20/04/16 11:30	20/04/16 11:45	20/04/16 12:00	20/04/16 12:15	20/04/16 12:30	20/04/16 12:45	20/04/16 13:00	20/04/16 13:15	20/04/16 13:30
Maximum VDC Supply	-	-	-	-	-	-	-	-	14.125	14.125
Minimum VDC Supply	-	-	-	-	-	-	-	-	14.017	14.017
Maximum 3.3V Supply	-	-	-	-	-	-	-	-	3.294	3.294
Minimum 3.3V Supply	-	-	-	-	-	-	-	-	3.277	3.277
Maximum 5V Supply	-	-	-	-	-	-	-	-	5.264	5.264
Minimum 5V Supply	-	-	-	-	-	-	-	-	5.224	5.223
Maximum 15V Supply	-	-	-	-	-	-	-	-	13.100	13.100
Minimum 15V Supply	-	-	-	-	-	-	-	-	13.043	13.043

The History Daily button presents a log of results every day.

Power Supply	10/04/16	11/04/16	12/04/16	13/04/16	14/04/16	15/04/16	16/04/16	17/04/16	18/04/16	19/04/16
Maximum VDC Supply	-	-	-	-	-	-	-	-	-	14.125
Minimum VDC Supply	-	-	-	-	-	-	-	-	-	14.027
Maximum 3.3V Supply	-	-	-	-	-	-	-	-	-	3.293
Minimum 3.3V Supply	-	-	-	-	-	-	-	-	-	3.283
Maximum 5V Supply	-	-	-	-	-	-	-	-	-	5.264
Minimum 5V Supply	-	-	-	-	-	-	-	-	-	5.224
Maximum 15V Supply	-	-	-	-	-	-	-	-	-	13.100
Minimum 15V Supply	-	-	-	-	-	-	-	-	-	13.043

## Monitoring > Serial

This page displays the current radio performance monitoring parameters per serial port in packet and byte level granularity, for serial port high level statistics and troubleshooting.

The results shown are since the page was opened and are updated automatically every 12 seconds.

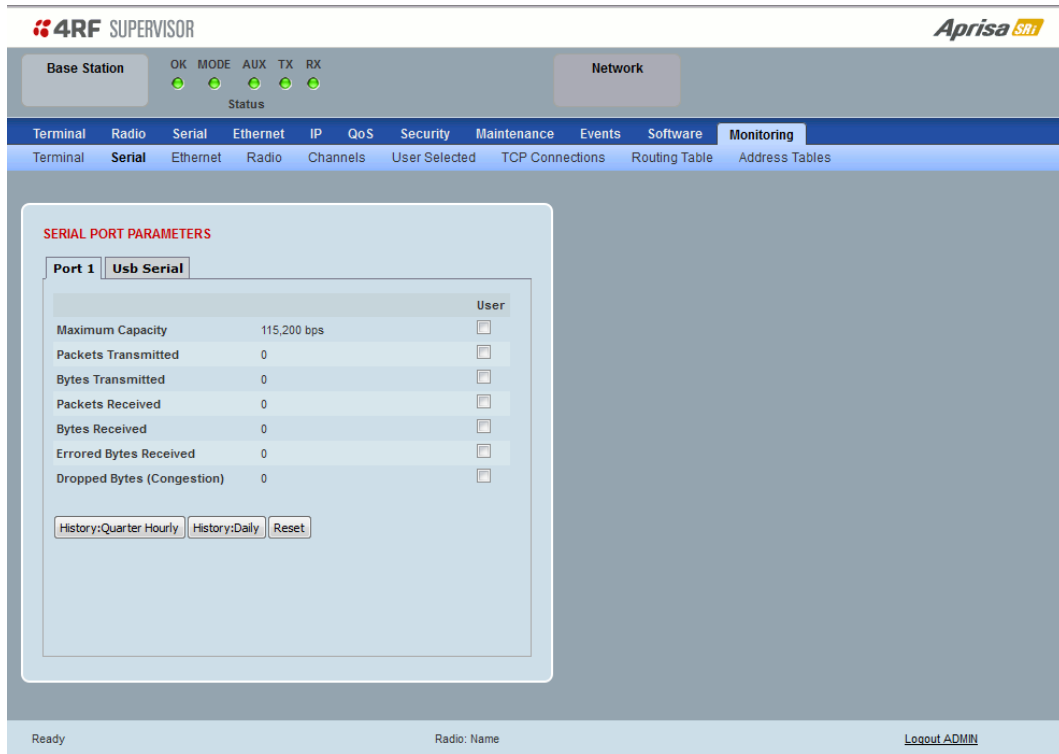

### SERIAL PORT PARAMETERS

#### All Serial Ports

Monitored Parameter	Function	Normal Operating Limits
Maximum Capacity	Parameter to show the maximum serial data rate of the serial port	Equal to the serial port baud rate setting
Packets Transmitted	Parameter to show the number of packets transmitted to the customer from the serial port	
Packets Received	Parameter to show the number of packets received from the customer into the serial port	
Bytes Received	Parameter to show the number of bytes received from the customer into the serial port	
Errored Bytes Received	Parameter to show the number of bytes received from the customer into the serial port that have errors	
Dropped Bytes (Congestion)	Parameter to show the number of bytes received from the customer into the serial port that are dropped due to over the air congestion	

#### Controls

The Reset button clears the current results.

## Monitoring > Ethernet

This page displays the current radio performance monitoring parameters per Ethernet port transmission (TX) out of the radio in packet and byte level granularity, for Ethernet port high level statistics and troubleshooting.

The results shown are since the page was opened and are updated automatically every 12 seconds.

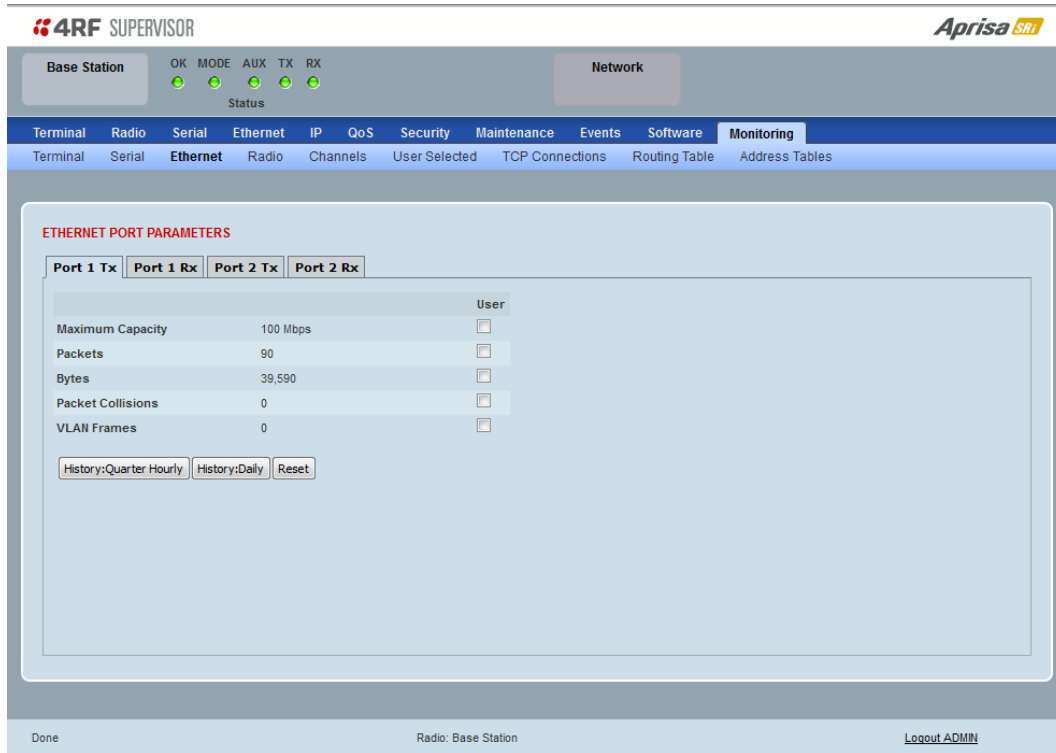

### ETHERNET PORT PARAMETERS

#### All Ethernet Ports TX

Monitored Parameter	Function	Normal Operating Limits
Maximum Capacity	Parameter to show the maximum Ethernet data rate of the Ethernet port	Equal to the Ethernet port speed setting
Packets	Parameter to show the number of packets transmitted to the customer from the Ethernet port	
Bytes	Parameter to show the number of bytes transmitted to the customer from the Ethernet port	
Packet Collisions	Parameter to show the number of packet collisions on the data transmitted to the customer from the Ethernet port on a shared LAN	
VLAN Frames	Parameter to show the number of VLAN tagged frames transmitted to the customer from the Ethernet port	



## Controls

The Reset button clears the current results.

The History Quarter Hourly button presents a log of results every quarter of an hour.

**4RF SUPERVISOR** **Aprisa SRI**

Base Station OK MODE AUX TX RX Network  
Status

Terminal Radio Serial Ethernet IP QoS Security Maintenance Events Software **Monitoring**

Terminal Serial **Ethernet** Radio Channels User Selected TCP Connections Routing Table Address Tables

**Ethernet Port 1 Transmit History, Quarter Hourly**

Ethernet Port 1 Transmit	20/04/16 11:15	20/04/16 11:30	20/04/16 11:45	20/04/16 12:00	20/04/16 12:15	20/04/16 12:30	20/04/16 12:45	20/04/16 13:00	20/04/16 13:15	20/04/16 13:30
Maximum Capacity (Mb/s)	-	-	-	-	-	-	-	-	100	100
Packets	-	-	-	-	-	-	-	-	508	1,000
Bytes	-	-	-	-	-	-	-	-	113,844	369,316
Packet Collisions	-	-	-	-	-	-	-	-	0	0
VLAN Frames	-	-	-	-	-	-	-	-	0	0

Viewing 11:15 to 13:30 of 11:15 to 13:30 Left Right

13:45 19/04/16  20/04/16 Downloaded 1  
13:30 to 13:30 Cancel

Ready Radio: Base Station [Logout ADMIN](#)

The History Daily button presents a log of results every day.

**4RF SUPERVISOR** **Aprisa SRI**

Base Station OK MODE AUX TX RX Network  
Status

Terminal Radio Serial Ethernet IP QoS Security Maintenance Events Software **Monitoring**

Terminal Serial **Ethernet** Radio Channels User Selected TCP Connections Routing Table Address Tables

**Ethernet Port 1 Transmit History, Daily**

Ethernet Port 1 Transmit	10/04/16	11/04/16	12/04/16	13/04/16	14/04/16	15/04/16	16/04/16	17/04/16	18/04/16	19/04/16
Maximum Capacity (Mb/s)	-	-	-	-	-	-	-	-	-	100
Packets	-	-	-	-	-	-	-	-	-	35,883
Bytes	-	-	-	-	-	-	-	-	-	8,916,976
Packet Collisions	-	-	-	-	-	-	-	-	-	0
VLAN Frames	-	-	-	-	-	-	-	-	-	0

Viewing 10/04/16 to 19/04/16 of 10/04/16 to 19/04/16 Left Right

20/03/16  Downloaded 1  
19/04/16 to 19/04/16 Cancel

Ready Radio: Base Station [Logout ADMIN](#)

This page displays the current radio performance monitoring parameters per Ethernet port received (RX) data in packet and byte level granularity, for Ethernet port high level statistics and troubleshooting.

The results shown are since the page was opened and are updated automatically every 12 seconds.

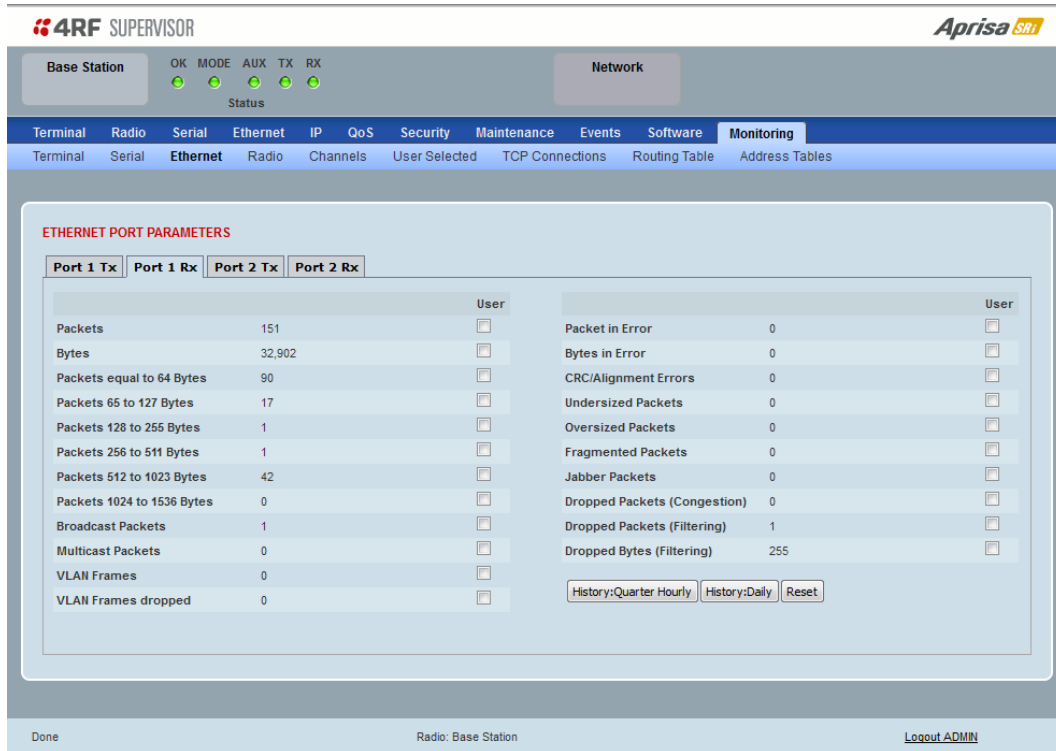

## ETHERNET PORT PARAMETERS

### All Ethernet Ports RX

Monitored Parameter	Function
Packets	Parameter to show the number of packets received by the customer from the Ethernet port (including bad packets, broadcast packets, and multicast packets)
Bytes	Parameter to show the number of bytes received (including those in bad packets) by the customer from the Ethernet port (excluding framing bits but including FCS octets)
Packets equal to 64 bytes	Parameter to show the number of packets received (including bad packets) from the customer into the Ethernet port that are equal to 64 bytes (excluding framing bits but including FCS octets)
Packets 65 to 127 bytes	Parameter to show the number of packets received (including bad packets) from the customer into the Ethernet port that are between 65 and 127 bytes (excluding framing bits but including FCS octets)
Packets 128 to 255 bytes	Parameter to show the number of packets received (including bad packets) from the customer into the Ethernet port that are between 128 and 255 bytes (excluding framing bits but including FCS octets)
Packets 256 to 511 bytes	Parameter to show the number of packets received (including bad packets) from the customer into the Ethernet port that are between 256 and 511 bytes (excluding framing bits but including FCS octets)
Packets 512 to 1023 bytes	Parameter to show the number of packets received (including bad packets) from the customer into the Ethernet port that are between 512 and 1023 bytes (excluding framing bits but including FCS octets)
Packets 1024 to 1536 bytes	Parameter to show the number of packets received (including bad packets) from the customer into the Ethernet port that are between 1024 and 1536 bytes (excluding framing bits but including FCS octets)
Broadcast Packets	Parameter to show the number of broadcast packets received from the customer into the Ethernet port. Broadcast packets are good packets received that were directed to the broadcast address. Note that this does not include multicast packets.

Monitored Parameter	Function
Multicast Packets	Parameter to show the number of multicast packets received from the customer into the Ethernet port. Multicast packets are packets that were directed to a multicast address. Note that this number does not include packets directed to the broadcast address.
VLAN Frames	Parameter to show the number of VLAN tagged frames received from the customer into the Ethernet port
VLAN Frames Dropped	Parameter to show the number of VLAN tagged frames received from the customer into the Ethernet port that were dropped due to CRC errored frames, filtered VLAN frames, undersized frames or oversized frames.
Packet In Error	Parameter to show the number of errored packets received from the customer into the Ethernet port caused by CRC errors, FCS Errors, alignment errors, oversized packets, undersized packets, fragmented packets and jabber packets
Bytes In Error	Parameter to show the number of errored bytes received from the customer into the Ethernet port
CRC / Alignment Error	Parameter to show the number of CRC / alignment errors received from the customer into the Ethernet port. CRC / alignment errors are defined as frames that had a length excluding framing bits, but including FCS octets of between 64 and 1518 octets, inclusive, but had either a bad Frame Check Sequence (FCS) with an integral number of octets (FCS Error) or a bad FCS with a non-integral number of octets.
Undersized Packets	Parameter to show the number of undersized packets received from the customer into the Ethernet port. Undersized packets are less than 64 octets long excluding framing bits, but including FCS octets.
Oversized Packets	Parameter to show the number of oversized packets received from the customer into the Ethernet port. Oversized packets are longer than 1518 octets excluding framing bits, but including FCS octets.
Fragmented Packets	Parameter to show the number of fragmented packets received from the customer into the Ethernet port. Fragmented packets have either a bad Frame Check Sequence (FCS) with an integral number of octets (FCS Error) or a bad FCS.
Jabber Packets	Parameter to show the number of jabber packets received from the customer into the Ethernet port
Dropped Packets (congestion)	Parameter to show the number of dropped packets received from the customer into the Ethernet port caused by congestion
Dropped Packets (filtering)	Parameter to show the number of dropped packets received from the customer into the Ethernet port caused by packet L2 / L3 filtering
Dropped Bytes (filtering)	Parameter to show the number of dropped bytes received from the customer into the Ethernet port caused by packet L2 / L3 filtering

### Controls

The Reset button clears the current results.

The History Quarter Hourly button presents a log of results every quarter of an hour.

Ethernet Port 1 Receive	20/04/16 11:15	20/04/16 11:30	20/04/16 11:45	20/04/16 12:00	20/04/16 12:15	20/04/16 12:30	20/04/16 12:45	20/04/16 13:00	20/04/16 13:15	20/04/16 13:30
Packets	-	-	-	-	-	-	-	-	1,131	1,479
Bytes	-	-	-	-	-	-	-	-	127,166	243,211
Packets equal to 64 Bytes	-	-	-	-	-	-	-	-	928	1,081
Packets 65 to 127 Bytes	-	-	-	-	-	-	-	-	92	113
Packets 128 to 255 Bytes	-	-	-	-	-	-	-	-	2	1
Packets 256 to 511 Bytes	-	-	-	-	-	-	-	-	17	33
Packets 512 to 1023 Bytes	-	-	-	-	-	-	-	-	92	251
Packets 1024 to 1536 Bytes	-	-	-	-	-	-	-	-	0	0
Broadcast Packets	-	-	-	-	-	-	-	-	568	533
Multicast Packets	-	-	-	-	-	-	-	-	15	14
VLAN Frames	-	-	-	-	-	-	-	-	0	0
VLAN Frames Dropped	-	-	-	-	-	-	-	-	0	0
Packets in Error	-	-	-	-	-	-	-	-	0	0
Bytes in Error	-	-	-	-	-	-	-	-	0	0
CRC/Alignment Errors	-	-	-	-	-	-	-	-	0	0
Undersized Packets	-	-	-	-	-	-	-	-	0	0
Oversized Packets	-	-	-	-	-	-	-	-	0	0
Fragmented Packets	-	-	-	-	-	-	-	-	0	0
Jabber Packets	-	-	-	-	-	-	-	-	0	0
Dropped Packets (Congestion)	-	-	-	-	-	-	-	-	0	0
Dropped Packets (Filtering)	-	-	-	-	-	-	-	-	0	0
Dropped Bytes (Filtering)	-	-	-	-	-	-	-	-	0	0

Viewing 11:15 to 13:30 of 11:15 to 13:30

13:45 19/04/16 | 13:30 to 13:30 | 13:30 20/04/16

Downloaded 1

The History Daily button presents a log of results every day.

Ethernet Port 1 Receive	10/04/16	11/04/16	12/04/16	13/04/16	14/04/16	15/04/16	16/04/16	17/04/16	18/04/16	19/04/16
Packets	-	-	-	-	-	-	-	-	-	65,803
Bytes	-	-	-	-	-	-	-	-	-	9,384,892
Packets equal to 64 Bytes	-	-	-	-	-	-	-	-	-	46,368
Packets 65 to 127 Bytes	-	-	-	-	-	-	-	-	-	9,765
Packets 128 to 255 Bytes	-	-	-	-	-	-	-	-	-	47
Packets 256 to 511 Bytes	-	-	-	-	-	-	-	-	-	616
Packets 512 to 1023 Bytes	-	-	-	-	-	-	-	-	-	9,001
Packets 1024 to 1536 Bytes	-	-	-	-	-	-	-	-	-	6
Broadcast Packets	-	-	-	-	-	-	-	-	-	20,866
Multicast Packets	-	-	-	-	-	-	-	-	-	558
VLAN Frames	-	-	-	-	-	-	-	-	-	0
VLAN Frames Dropped	-	-	-	-	-	-	-	-	-	0
Packets in Error	-	-	-	-	-	-	-	-	-	0
Bytes in Error	-	-	-	-	-	-	-	-	-	0
CRC/Alignment Errors	-	-	-	-	-	-	-	-	-	0
Undersized Packets	-	-	-	-	-	-	-	-	-	0
Oversized Packets	-	-	-	-	-	-	-	-	-	0
Fragmented Packets	-	-	-	-	-	-	-	-	-	0
Jabber Packets	-	-	-	-	-	-	-	-	-	0
Dropped Packets (Congestion)	-	-	-	-	-	-	-	-	-	0
Dropped Packets (Filtering)	-	-	-	-	-	-	-	-	-	0
Dropped Bytes (Filtering)	-	-	-	-	-	-	-	-	-	0

Viewing 10/04/16 to 19/04/16 of 10/04/16 to 19/04/16

20/03/16 | 19/04/16 to 19/04/16

Downloaded 1

## Monitoring > Radio

This page displays the current radio diagnostic and performance monitoring parameters of the radio transmitter.

The results shown are since the page was opened and are updated automatically every 12 seconds.

## RADIO PARAMETERS

### Transmitter

Monitored Parameter	Function	Normal Operating Limits
Current Temperature	Parameter to show the current temperature of the transmitter	0 to 70 °C
Packets Transmitted	Parameter to show the number of packets transmitted over the air	
Bytes Transmitted	Parameter to show the number of bytes transmitted over the air	
Dropped Packets (congestion)	Parameter to show the number of dropped packets transmitted over the air caused by congestion	
Dropped Bytes (congestion)	Parameter to show the number of dropped bytes transmitted over the air caused by congestion	
Last TX Packet PA Current	Parameter to show the current consumed by the transmitter power amplifier in mA. The value is stored from the last time the transmitter was active and transmitted a packet.	This value will change depending on the transmitter power setting, modulation, temperature and the VSWR of the antenna. The alarm limits for this are 50 mA to 2.5 A
Last TX Packet Driver Current	Parameter to show the current consumed by the transmitter power amplifier driver in mA. The value is stored from the last time the transmitter was active and transmitted a packet.	This value will change depending on the transmitter power setting, modulation and temperature. The alarm limits for the PA Driver Current are 10 mA to 500 mA.

Monitored Parameter	Function	Normal Operating Limits
Last TX Packet Forward Power	Parameter to show the actual transmitter power in dBm. The value is stored from the last time the transmitter was active and transmitted a packet.	This value will be dependent on the output power, the temperature and the VSWR of the antenna. The alarm limits for the Tx forward power are +/-4 dB.

### Controls

The Reset button clears the current results.

This page displays the current radio performance monitoring parameters of radio receiver. The results shown are since the page was opened and are updated automatically every 12 seconds.

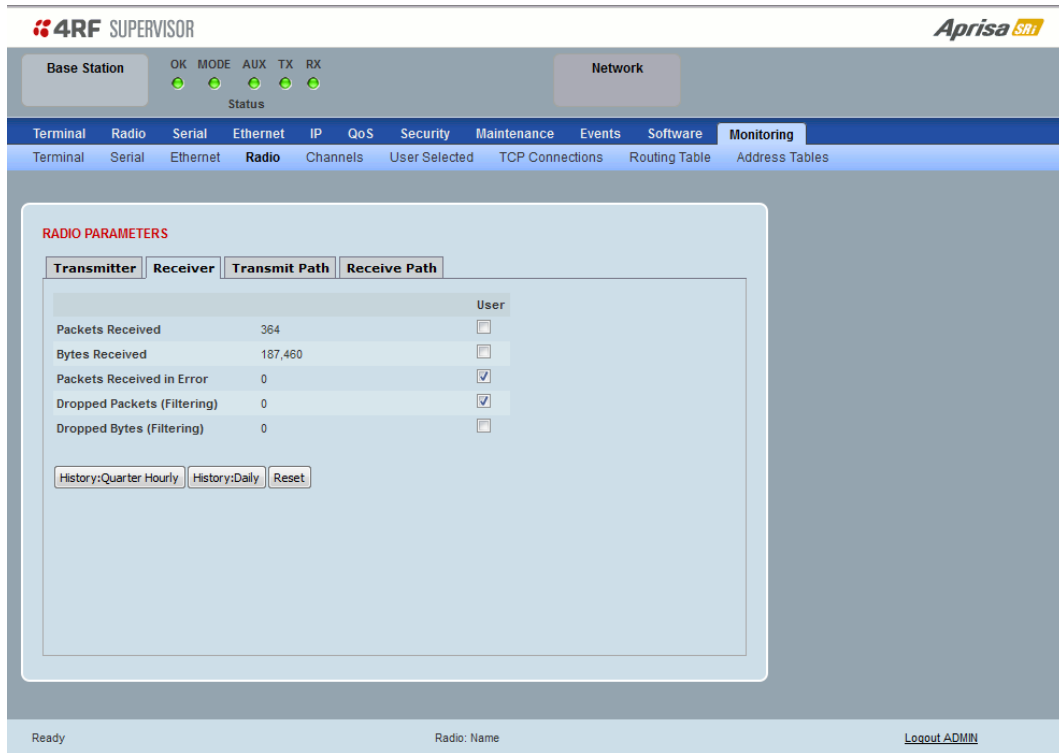

## RADIO PARAMETERS

### Receiver

Monitored Parameter	Function
Packets Received	Parameter to show the number of packets received over the air
Bytes Received	Parameter to show the number of bytes received over the air
Packets Received In Error	Parameter to show the number of packets received over the air
Dropped Packets (filtering)	Parameter to show the number of dropped packets received over the air caused by L2 / L3 filtering
Dropped Bytes (filtering)	Parameter to show the number of dropped bytes received over the air caused by L2 / L3 filtering

### Controls

The Reset button clears the current results.

This page displays the current radio RF transmit path modulation setting to single or multiple destination radios that the radio is transmitting to.

The results shown are since the page was opened and are updated automatically every 12 seconds.

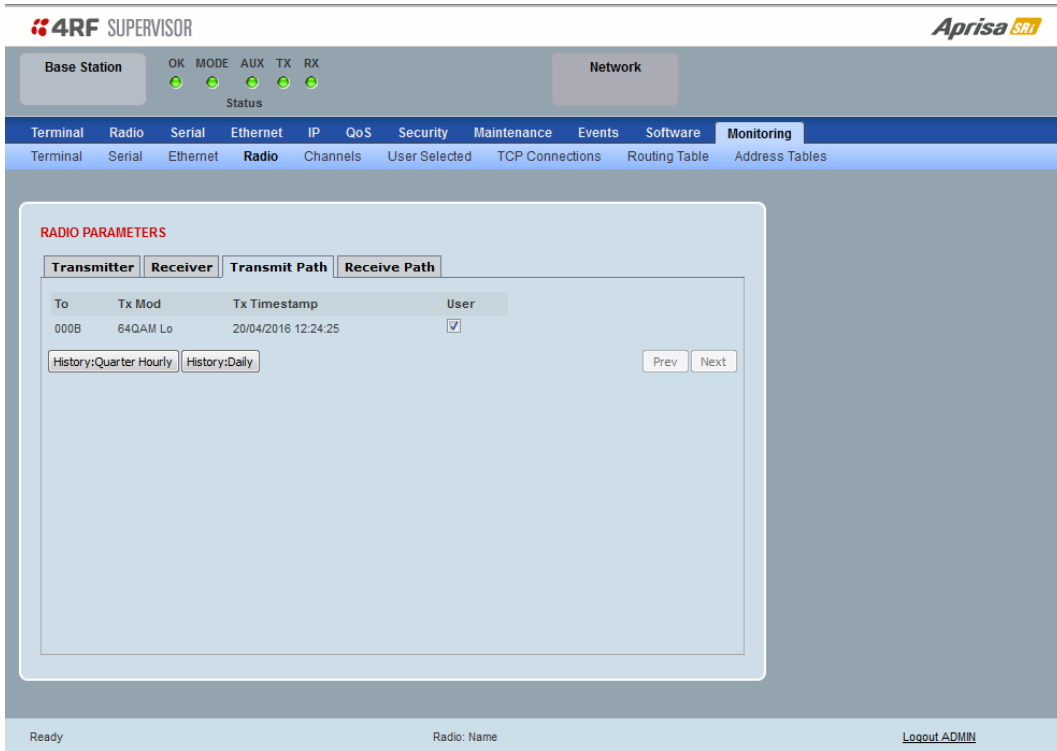

## RADIO PARAMETERS

Result	Function
To	The destination Node Address of the radio/s transmitting data to.
Tx Mod	The current radio transmitter modulation being used to communicate with the destination radio/s.
Tx Timestamp	The timestamp of the last transmitted packet to the destination radio/s.

## Controls

The Next button will display the next page of 8 radios and the Prev button will display the previous page of 8 radios.



This page displays the current radio RF receive path parameters from single or multiple source radios that the radio is receiving from.

The results shown are since the page was opened and are updated automatically every 12 seconds.

## RADIO PARAMETERS

### Receive Path

Result	Function
From	The source Node Address of the radio receiving data from.
Rx RSSI	The RSSI of the RF signal received from the source radio/s. This parameter displays the receiver RSSI reading taken from the last data packet received.
Rx Freq Error	The frequency difference between this radio's receiver and the frequency of the incoming packet rate from the source radio/s.
Rx Mod	The current radio receive modulation being used to communicate with the source radio/s.
Rx Timestamp	The timestamp of the last received packet from the source radio/s.

### Controls

The Next button will display the next page of 8 radios and the Prev button will display the previous page of 8 radios.

## Monitoring > Channels

This page displays the current radio diagnostic and performance monitoring parameters of the channels. The results shown are since the page was opened and are updated automatically every 12 seconds.

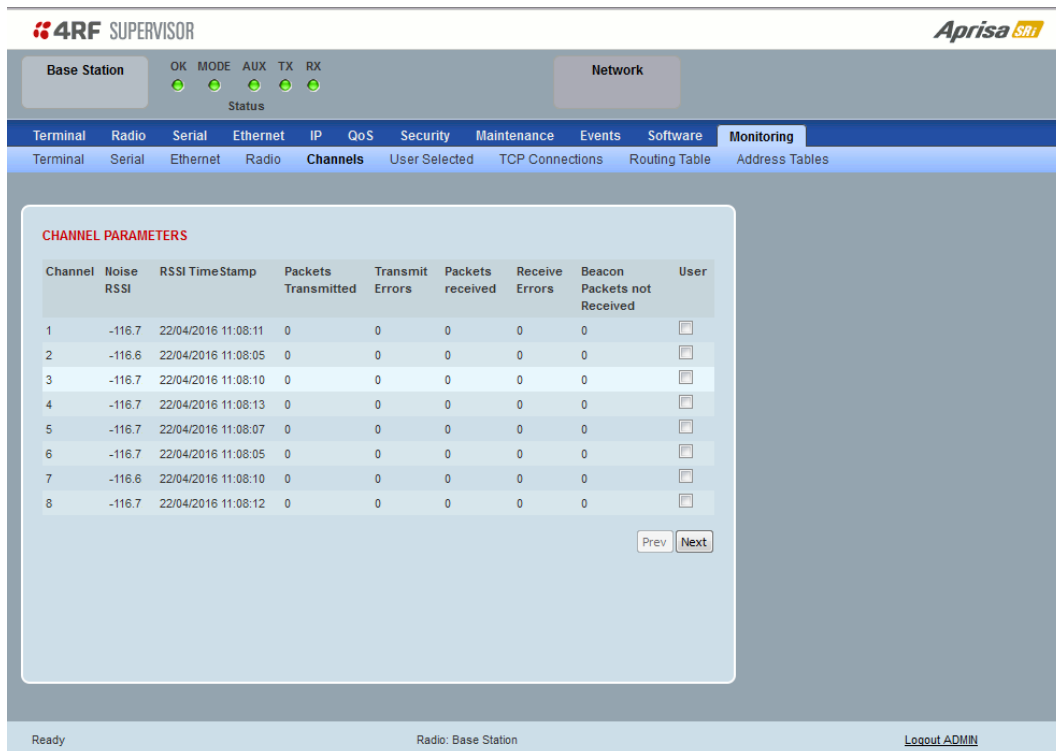

**CHANNEL PARAMETERS**

Channel	Noise RSSI	RSSI TimeStamp	Packets Transmitted	Transmit Errors	Packets received	Receive Errors	Beacon Packets not Received	User
1	-116.7	22/04/2016 11:08:11	0	0	0	0	0	<input type="checkbox"/>
2	-116.6	22/04/2016 11:08:05	0	0	0	0	0	<input type="checkbox"/>
3	-116.7	22/04/2016 11:08:10	0	0	0	0	0	<input type="checkbox"/>
4	-116.7	22/04/2016 11:08:13	0	0	0	0	0	<input type="checkbox"/>
5	-116.7	22/04/2016 11:08:07	0	0	0	0	0	<input type="checkbox"/>
6	-116.7	22/04/2016 11:08:05	0	0	0	0	0	<input type="checkbox"/>
7	-116.6	22/04/2016 11:08:10	0	0	0	0	0	<input type="checkbox"/>
8	-116.7	22/04/2016 11:08:12	0	0	0	0	0	<input type="checkbox"/>

Prev Next

Ready Radio: Base Station Logout ADMIN

### CHANNEL PARAMETERS

Result	Function
Channel	The channel number.
Noise RSSI	The RSSI measured when the channel is clear. It is used to determine if interference is present.
RSSI Timestamp	The timestamp of the last received packet used for RSSI.
Packets Transmitted	The number of packets transmitted from the radio.
Transmit Errors	The number of transmit packets not acknowledged by the base station.
Packets Received	The number of packets received by the radio.
Receive Errors	The number of errored packets received by the radio.
Beacon Packets Not Received	The base station sends broadcast beacon packets to the remotes to sync to the hop channels. This is the number of Beacon Packets not received at the remotes.

### Controls

The Next button will display the next page of 8 connections and the Prev button will display the previous page of 8 connections.

## Monitoring > User Selected

This page displays the 'User' parameters setup in all the other Monitoring screens e.g. in the Monitoring > Radio > Transmitter, the User checkbox is ticked for the Dropped Packets (Congestion) and Dropped Bytes (Congestion).

The results shown are since the page was opened and are updated automatically every 12 seconds.

**4RF SUPERVISOR** **Aprisa SRI**

Base Station: OK MODE AUX TX RX Status

Network

Terminal Radio Serial Ethernet IP QoS Security Maintenance Events Software **Monitoring**

Terminal Serial Ethernet Radio Channels **User Selected** TCP Connections Routing Table Address Tables

**TERMINAL PARAMETERS**

RF Transmitter		User
Bytes Transmitted	937	<input checked="" type="checkbox"/>
Dropped Packets (Congestion)	0	<input checked="" type="checkbox"/>
Dropped Bytes (Congestion)	0	<input checked="" type="checkbox"/>
RF Receiver		User
Packets Received in Error	0	<input checked="" type="checkbox"/>
Dropped Packets (Filtering)	0	<input checked="" type="checkbox"/>

**RF LINK PARAMETERS**

Transmit Path		User
Remote Node Address	000B	<input checked="" type="checkbox"/>
Modulation	64QAM Lo	
Timestamp	20/04/2016 12:25:23	
Receive Path		User
Remote Node Address	000B	<input checked="" type="checkbox"/>
RSSI	-95.7 dBm	
SNR	13.5 dB	
Frequency Error	23 Hz	
Modulation	QPSK Lo	
Timestamp	20/04/2016 12:25:24	

Ready Radio: Name [Logout ADMIN](#)

### Controls

The Reset button clears the current results.

## Monitoring &gt; TCP Connections

This page displays the list of active TCP connections on the radio.

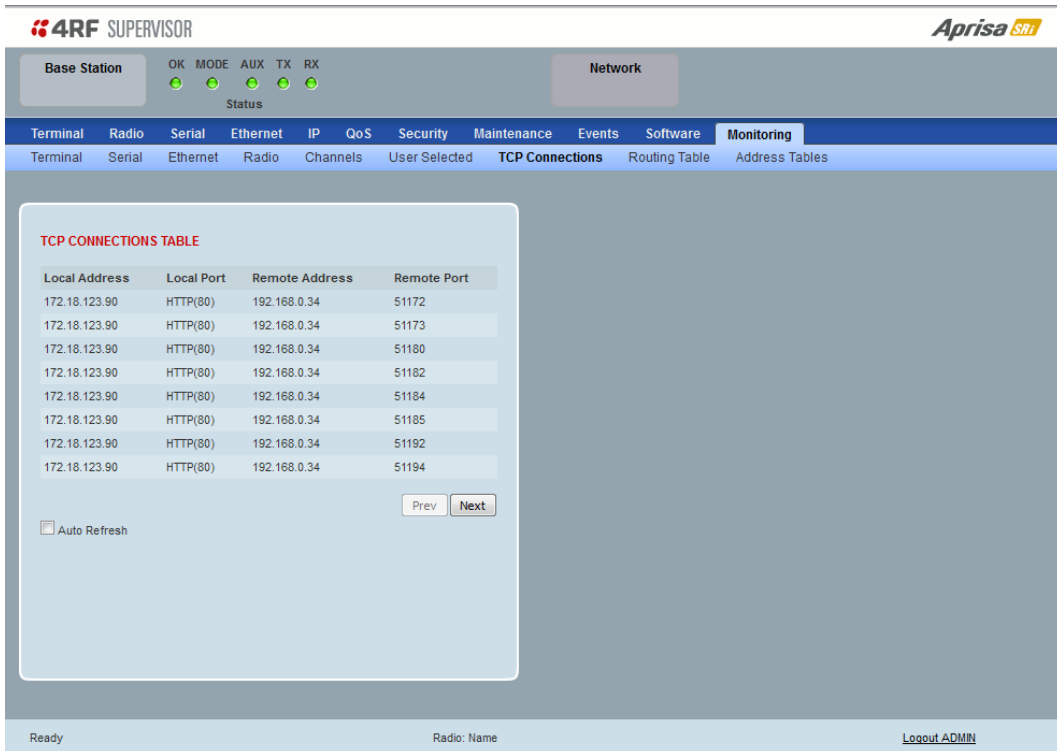

**4RF SUPERVISOR** **Aprisa SRI**

Base Station OK MODE AUX TX RX Network  
Status

Terminal Radio Serial Ethernet IP QoS Security Maintenance Events Software **Monitoring**

Terminal Serial Ethernet Radio Channels User Selected **TCP Connections** Routing Table Address Tables

**TCP CONNECTIONS TABLE**

Local Address	Local Port	Remote Address	Remote Port
172.18.123.90	HTTP(80)	192.168.0.34	51172
172.18.123.90	HTTP(80)	192.168.0.34	51173
172.18.123.90	HTTP(80)	192.168.0.34	51180
172.18.123.90	HTTP(80)	192.168.0.34	51182
172.18.123.90	HTTP(80)	192.168.0.34	51184
172.18.123.90	HTTP(80)	192.168.0.34	51185
172.18.123.90	HTTP(80)	192.168.0.34	51192
172.18.123.90	HTTP(80)	192.168.0.34	51194

Auto Refresh Prev Next

Ready Radio: Name Logout ADMIN

## TCP CONNECTIONS TABLE

Result	Function
Local Address	The local radio IP address
Local Port	The local radio TCP port number
Remote Address	The remote host IP address (in most case a host PC connected to radio/network)
Remote Port	The local radio TCP port number (in most case a host PC connected to radio / network)

## Controls

The Next button will display the next page of 8 connections and the Prev button will display the previous page of 8 connections.

If the Auto Refresh option is ticked, the TCP Connections table will refresh every 12 seconds.

## Monitoring > Routing Table

This page displays the list of active routes on the radio.

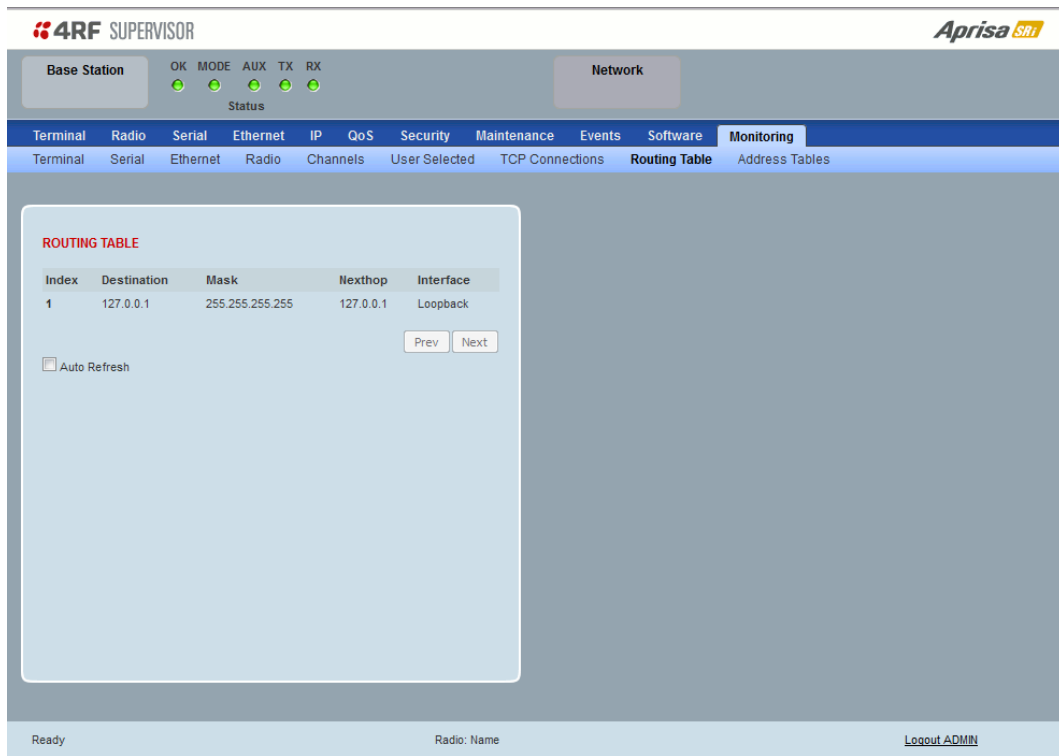

### ROUTING TABLE

Result	Function
Index	The routing table index
Destination	The target destination IP address of the route
Mask	The subnet mask of the destination IP address of the route
Next Hop	The next hop IP address on the path to the destination IP address of the route
Interface	The physical interface output on the path to the destination IP address of the route

### Controls

The Next button will display the next page of 8 routes and the Prev button will display the previous page of 8 routes.

If the Auto Refresh option is ticked, the routing table will refresh every 12 seconds.

## Monitoring > Address Tables

### ARP Table

This page displays the current Address Resolution Protocols (ARP) on the radio. The radio implemented ARP protocol is used for resolution of network layer addresses into link layer addresses. It is used to map a IPv4 address to an Ethernet MAC address. The ARP table shows the results of the ARP protocol linkage between IPv4 address and Ethernet MAC address of the devices attached to the radio.

In a layer 2 bridge LAN, an upper layer protocol may include the IP address of the destination, but since it is an Ethernet LAN network, it also needs to know the destination MAC address. First, the radio uses a cached ARP table to look up the IPv4 destination address for the matching MAC address records. If the MAC address is found, it sends the IPv4 packet encapsulated in Ethernet frame with the found MAC address. If the ARP cache table did not produce a result for the destination IPv4 address, the radio sends a broadcast ARP message requesting an answer (of MAC address that matches) for IP address. The destination device responds with its MAC address (and IP). The response information is cached in radios' ARP table and the message can now be sent with the appropriate destination MAC address.

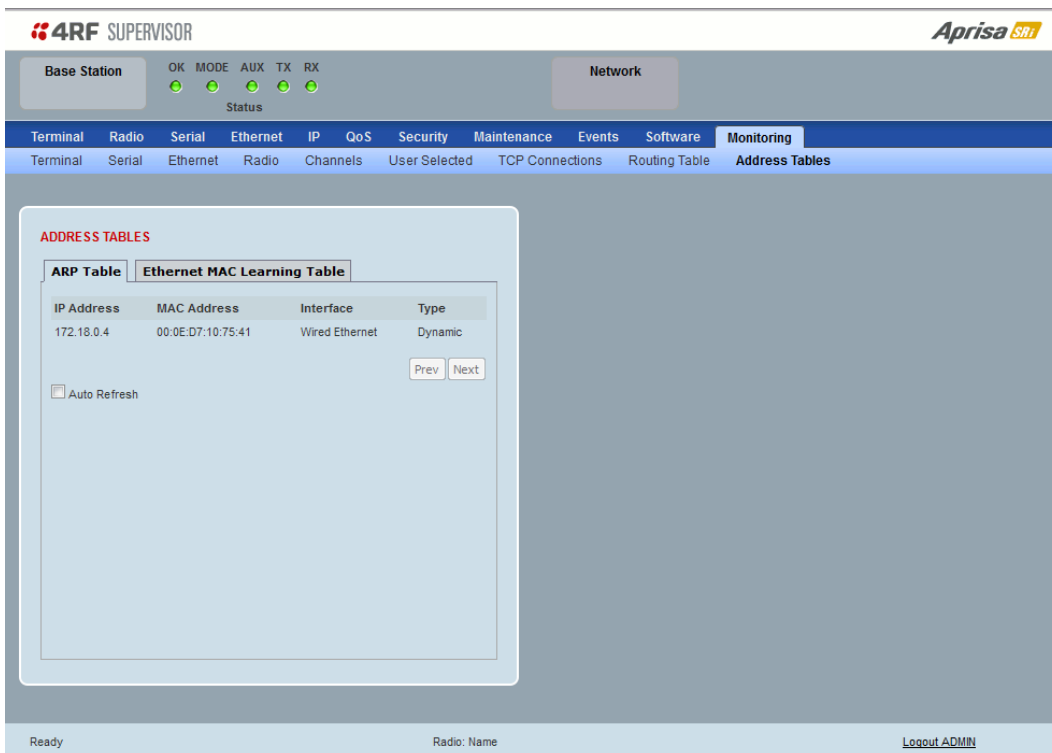

The screenshot shows the 4RF SUPERVISOR web interface. The top navigation bar includes 'Base Station' and 'Network'. The 'Monitoring' tab is selected, and the 'Address Tables' sub-tab is active. The 'ADDRESS TABLES' section contains two tabs: 'ARP Table' (selected) and 'Ethernet MAC Learning Table'. The ARP Table displays a single entry with the following details:

IP Address	MAC Address	Interface	Type
172.18.0.4	00:0E:D7:10:75:41	Wired Ethernet	Dynamic

Below the table, there is an 'Auto Refresh' checkbox and 'Prev' and 'Next' buttons. The status bar at the bottom indicates 'Ready' and 'Radio: Name', with a 'Logout ADMIN' link on the right.

### ADDRESS TABLES

Title	Function
IP Address	The IPv4 address of a neighboring device in the radio LAN network
MAC Address	The ARP result matching or mapping MAC address from the IPv4 address.
Interface	The Ethernet port interface the ARP results found the matching/mapping
Type	'Dynamic' indicates an ARP result and 'Static' indicates a user static mapping.

### Controls

The Next button will display the next page of 8 addresses and the Prev button will display the previous page of 8 addresses.

If the Auto Refresh option is ticked, the ARP table will refresh every 12 seconds.

## Ethernet MAC Learning Table

This page displays the current Ethernet Media Access Control (MAC) Address table on the radio LAN network. In order for the radio to switch frames between Ethernet LAN ports efficiently, the radio layer 2 bridge maintains a MAC address table. When the radio bridge receives a frame, it associates the MAC address of the sending network device with the LAN port on which it was received.

The bridge dynamically learns and builds the MAC address table by using the MAC source address of the frames received. When the radio bridge receives a frame for a MAC destination address not listed in its address table, it floods the frame to all LAN ports of the same LAN (or in case of VLAN, to the specific VLAN) except the port that received the frame. When the destination bridge device replies, the radio bridge adds its relevant MAC source address and interface port number to the MAC address table. The switch then forwards subsequent frames to a single LAN port without flooding all LAN ports.

The screenshot shows the 4RF SUPERVISOR interface. At the top, there are status indicators for 'Base Station' (OK, MODE, AUX, TX, RX) and 'Network'. Below this is a navigation menu with 'Monitoring' selected. The main content area displays the 'ADDRESS TABLES' section, with 'Ethernet MAC Learning Table' selected. The table contains the following data:

MAC Address	Interface	Age Left (Sec)
00:0c:10:0b:31:2a	Radio Path	21
00:0e:d7:10:75:41	Ethernet Port 1	294
00:22:b2:00:15:83	Ethernet Port 1	84
00:22:b2:00:2a:40	Ethernet Port 1	273
00:50:c2:6b:3a:06	Ethernet Port 1	105
00:50:c2:6b:3d:bb	Ethernet Port 1	294

Below the table are 'Prev' and 'Next' buttons, and an 'Auto Refresh' checkbox.

## ADDRESS TABLES

Title	Function
MAC Address	The learned MAC address of a neighboring bridge device in the LAN network.
Interface	The Ethernet port interface the MAC address has learned
Age left	The aging time of this MAC entry will stay in the table, even if this MAC address is not used. Every time this MAC address is used, the aging time restarts from its maximum. Default is 300 sec.

### Controls

The Next button will display the next page of 8 addresses and the Prev button will display the previous page of 8 addresses.

If the Auto Refresh option is ticked, the routing table will refresh every 12 seconds.

## Network Status

### Network Status > Network Table

This page displays a list of all the registered remote stations for the base station and provides management access to each of the remote stations.

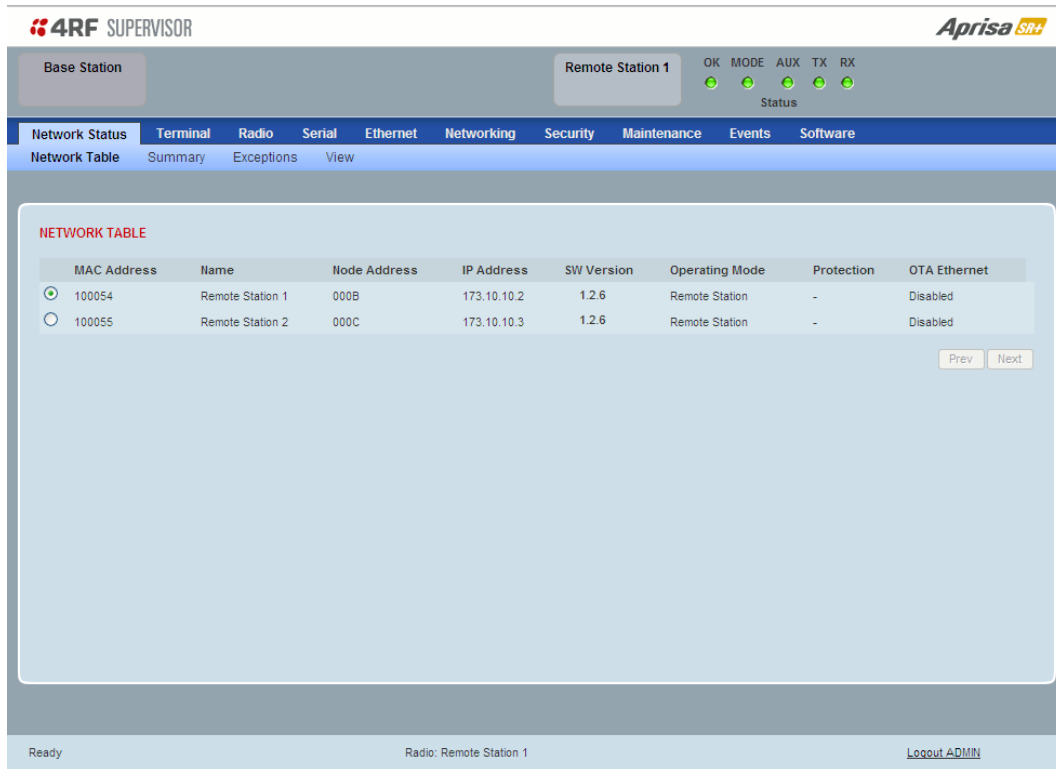

#### NETWORK TABLE

This Network Table is only available when the local radio is the base station i.e. SuperVisor is logged into the base station.

#### To manage a remote station with SuperVisor:

Click on the radio button of the required station. The remaining menu items then apply to the selected remote station.



## Network Status > Summary

Network View is an overview of the health of the network providing the ability to investigate issues directly within SuperVisor.

This page provides an overall summary view of the alarm status of all registered remote stations for the base station. When open, it provides a continuous monitor of the network.

Depending on the poll period set (20 seconds minimum) and the number of remotes in the network, it will take at least three poll cycles to indicate a failure in the network. Initial results may indicate 'All ok' until at least three poll cycles completed. This could take  $\text{Number Of Remotes} * \text{Poll Period} * 3$  seconds to complete.

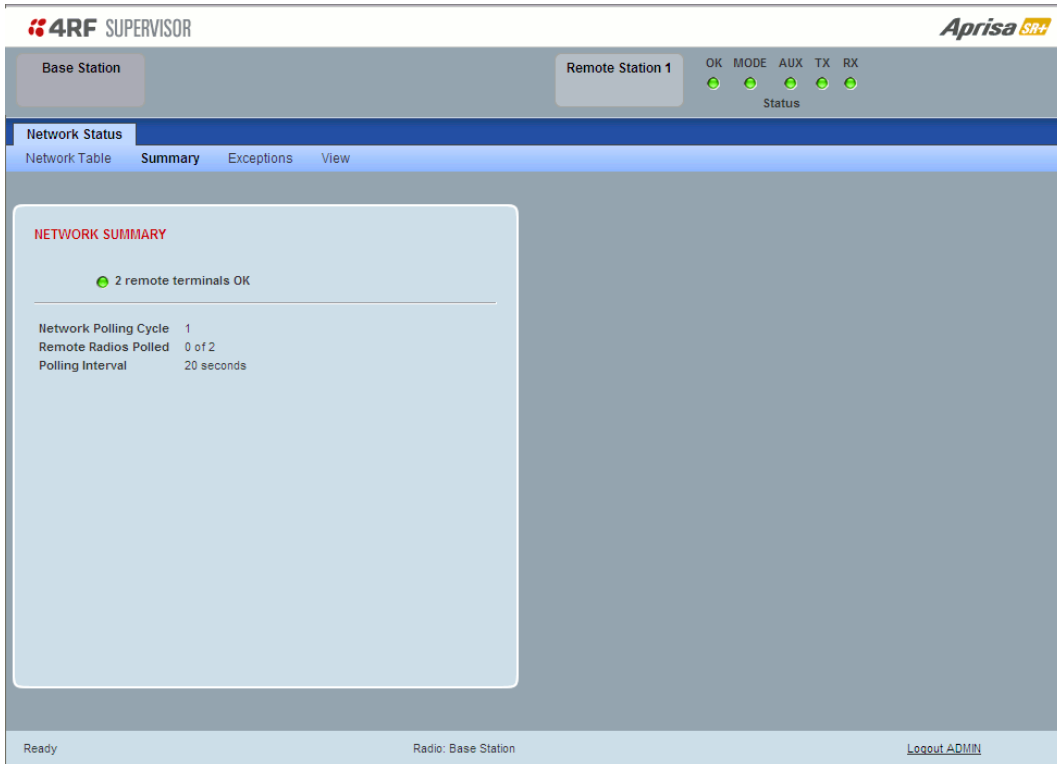

**4RF SUPERVISOR** **Aprisa SRi**

Base Station Remote Station 1 OK MODE AUX TX RX  
Status

**Network Status**

Network Table **Summary** Exceptions View

**NETWORK SUMMARY**

● 2 remote terminals OK

---

Network Polling Cycle 1  
 Remote Radios Polled 0 of 2  
 Polling Interval 20 seconds

Ready Radio: Base Station [Logout ADMIN](#)

## NETWORK SUMMARY

A network poll will start when any of the Network Status pages are opened (Summary, Exceptions or View). The network poll will only continue to poll the remote stations if one of the Network Status pages is open (SuperVisor can lose PC focus). The network poll continues from where it was stopped last time it was polling.

The initial result assumes that all remote stations are operating correctly.

Network Summary Example:

Result	Function
Network Polling Cycle	The number of poll cycles since first opening a Network Status > Summary, Exceptions or View page. The page example shows 6 polling cycles.
Remote Radios Polled	This shows the number of radios polled for the current polling cycle out of the number remote radios registered with the base station. The page example shows 1 radio polled for the current polling cycle out of 3 remote radios registered.
Polling Interval	The time interval between the completion of one radio poll and the start of the next radio poll. To set the polling interval, see 'Maintenance > General' on page 185.

If a remote radio does not respond to a poll request within 10 seconds, the previous readings from that radio will be presented. Connectivity to a remote radio will be show as 'lost' if the remote radio has not responded to 3 consecutive poll requests.

## Network Status > Exceptions

This page provides a list of all registered remote radios that are in an alarmed state or have stopped responding to the SuperVisor polling. When open, it provides a continuous monitor of the network.

### NETWORK EXCEPTIONS

A network poll will start when any of the Network Status pages are opened (Summary, Exceptions or View). The network poll will only continue to poll the remote stations if one of the Network Status pages is open (SuperVisor can lose PC focus). The network poll continues from where it was stopped last time it was polling.

Network Exceptions Example:

Result	Function
Network Polling Cycle	The number of poll cycles since first opening a Network Status > Summary, Exceptions or View page. The page example shows 4 polling cycles.
Remote Radios Polled	This shows the number of radios polled for the current polling cycle out of the number remote radios registered with the base station. The page example shows 3 radios polled for the current polling cycle out of 4 remote radios registered.
Polling Interval	The time interval between the completion of one radio poll and the start of the next radio poll. To set the polling interval, see 'Maintenance > General' on page 185.

If a remote radio does not respond to a poll request within 10 seconds, the previous readings from that radio will be presented. Connectivity to a remote radio will be shown as 'lost' if the remote radio has not responded to 3 consecutive poll requests.

If a remote radio on the list is detected to be responding to a poll request and no longer be in an alarmed state, the entry for this remote radio will be removed from the list.

#### *View Events*

Clicking on View Events navigates to the Events page (see 'Events' on page 197) for the specific remote radio where the radio events will be displayed.

#### *View Parameters*

Clicking on View Parameters navigates to the Monitoring page (see 'Monitoring' on page 227) for the specific remote radio where the radio parameters will be displayed.

## Network Status > View

This page provides a complete list of all registered remote radios. It is similar to the Exceptions page but it shows all radios, not limited to the radios with alarms. When open, it provides a continuous monitor of the network.

### NETWORK VIEW

A network poll will start when any of the Network Status pages are opened (Summary, Exceptions or View). The network poll will only continue to poll the remote stations if one of the Network Status pages is open (SuperVisor can lose PC focus). The network poll continues from where it was stopped last time it was polling.

#### Network View Example:

Result	Function
Network Polling Cycle	The number of poll cycles since first opening a Network Status > Summary, Exceptions or View page. The page example shows 2 polling cycles.
Remote Radios Polled	This shows the number of radios polled for the current polling cycle out of the number remote radios registered with the base station. The page example shows 1 radio polled for the current polling cycle out of 3 remote radios registered.
Polling Interval	The time interval between the completion of one radio poll and the start of the next radio poll. To set the polling interval, see 'Maintenance > General' on page 185. Note: as this polling feature utilizes air time, the polling interval should be selected to suit the network traffic.

If a remote radio does not respond to a poll request within 10 seconds, the previous readings from that radio will be presented. Connectivity to a remote radio will be show as 'lost' if the remote radio has not responded to 3 consecutive poll requests.

#### *View Events*

Clicking on View Events navigates to the Events page (see 'Events' on page 197) for the specific remote radio where the radio events will be displayed.

#### *View Parameters*

Clicking on View Parameters navigates to the Monitoring page (see 'Monitoring' on page 227) for the specific remote radio where the radio parameters will be displayed.

## Command Line Interface

The Aprisa SRi has a Command Line Interface (CLI) which provides basic product setup and configuration. This can be useful if you need to confirm the radio's IP address, for example.

You can password-protect the Command Line Interface to prevent unauthorized users from modifying radio settings.

This interface can be accessed via an Ethernet Port (RJ45), the Management Port (USB micro type B) or the USB host port  with a USB converter to RS-232 convertor.

## Connecting to the Management Port

A USB Cable USB A to USB micro B, 1m is provided with each radio.



1. Connect the USB A to your computer USB port and the USB micro B to the management port of the Aprisa SRi (MGMT).
2. Unzip the file 'USB Serial Driver CP210x\_VCP\_Windows.zip' to a temporary location and install the appropriate driver on your computer. This file is on the Information and setup CD supplied with the radio.

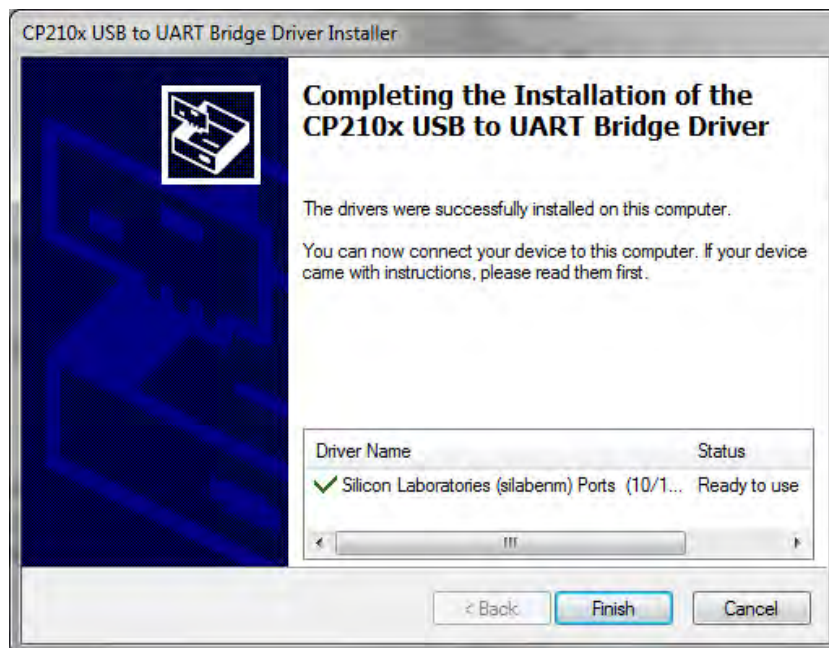

3. Go to your computer device manager (Win 7: Control Panel > Administrative Tools > Computer Management > Device Manager)
4. Click on 'Ports (COM & LPT)'
5. Make a note of the COM port which has been allocated to the 'Silicon Labs CP210x USB to UART Bridge' (COM3 in the example below)

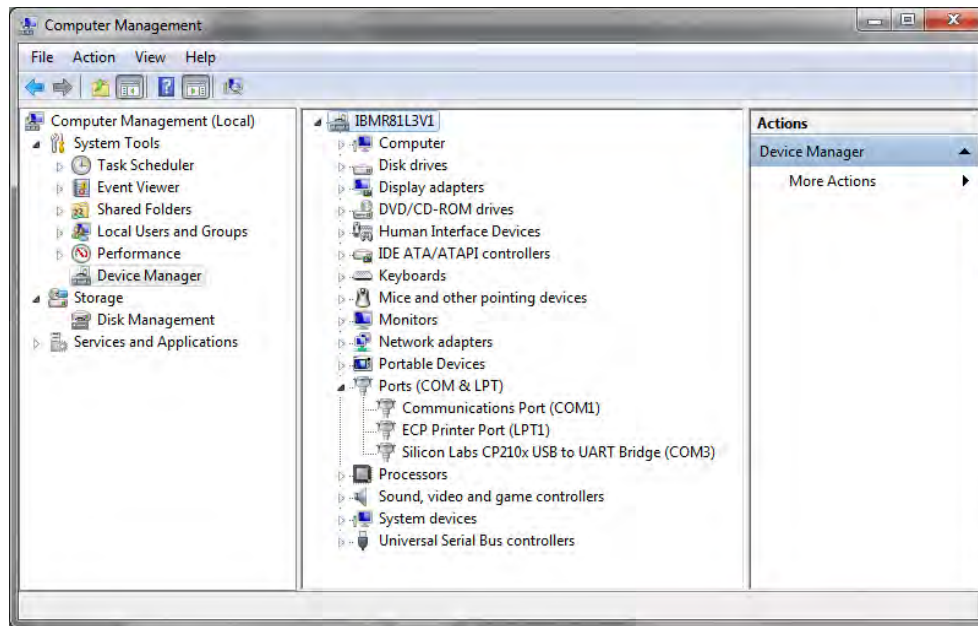

6. Open HyperTerminal or an alternative type of terminal Emulator program e.g. TeraTerm or Putty.

### HyperTerminal Example

7. Enter a name for the connection (Aprisa SRi CLI for example) and click OK.





- Select the COM port from the Connect Using drop-down box that was allocated to the UART USB.



- Set the COM port settings as follows:

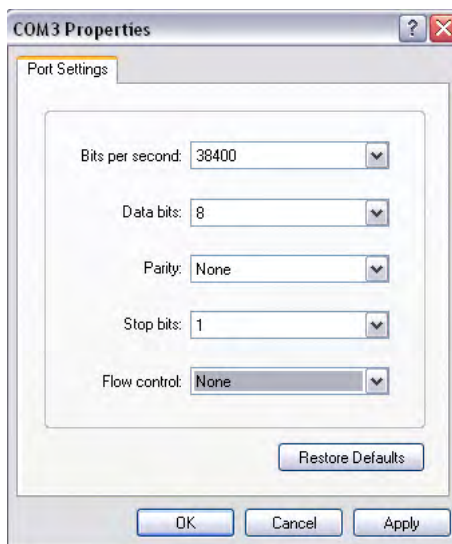

- Click OK. The HyperTerminal window will open.
- Press the Enter key to initiate the session.
- Login to the Aprisa SRi CLI with a default Username 'admin' and Password 'admin'.

The Aprisa SRi CLI menu is shown:

```

Login: admin
Password: *****
CLI user admin last login: 2011/01/01 22:29:34 from 127.0.0.1
>>?
adduser      browser      cd            clear        config
debug        deleteuser  editpasswd   edituser    get
list         logout      ls           nodelq      pwd
reboot      roh        set          who
>>
>>
    
```

## CLI Commands

To enter a CLI command:

1. Type the first few characters of the command and hit Tab. This auto completes the command.
2. Enter the command string and enter.

---

**Note:** All CLI commands are case sensitive.

---

The top level CLI command list is displayed by typing a ? at the command prompt.

The following is a list of the top level CLI commands and their usage:

CLI Command	Usage
adduser	adduser [-g <password aging>] [-a <account aging>] [-i <role>] <userName> <userPassword>
browser	browser <state(STR)>
cd	cd <changeMode(STR)>
clear	Clears the screen
config	config userdefault save restore factorydefault restore
debug	set subsystem param(INT) level param(INT) get clear subsystem param(INT) level param(INT) help log dump clear
deleteuser	deleteuser <userName>
editpasswd	editpasswd <oldpassword> <newpassword>
edituser	edituser [-p <password>] [-g <password aging>] [-a <account aging>] [-i]
get	get [-m <mib name>] [-n <module name>] <attribute name> [indexes]
list	list <tablename>
logout	Logs out from the CLI
ls	Displays the next level menu items
pwd	Displays the current working directory
reboot	Reboots the radio
set	set [-m <mib name> ] [-n <module name>] <attribute name> <attribute set value> [indexes]
who	Shows the users currently logged into the radio

## Viewing the CLI Terminal Summary

At the command prompt, type:

```
cd APRISASR-MIB-4RF
```

```
MPA APRISASR-MIB-4RF >>ls Terminal
```

```
>>cd APRISASR-MIB-4RF
MPA APRISASR-MIB-4RF >>ls Terminal
```

S.NO	ATTRIBUTE NAME	ATTRIBUTE VALUE
1	termName	Base Station
2	termLocation	Wellington
3	termContactName	4RF Limited
4	termContactDetails	support@4rf.com
5	termTimeFormat	time24h (1)
6	termDateFormat	ddmmyyyy (1)
7	termDateTime	2013-9-12,19:22:43.0
8	termEthController1IpAddress	173.10.10.1
9	termEthController1SubnetMask	255.255.0.0
10	termEthController1Gateway	0.0.0.0
11	termRfNwkPanId	CAFE
12	termRfNwkRadius	1
13	termInbandManagementEnabled	true (1)
14	termInbandManagementTimeoutSec	10
15	termRfNwkRepeaterProximity	noRepeater (0)

## Changing the Radio IP Address with the CLI

At the command prompt, type 'set termEthController1IpAddress xxx.xxx.xxx.xxx'

```
1 | termName | Base Station
2 | termLocation | Wellington
3 | termContactName | 4RF Limited
4 | termContactDetails | support@4rf.com
5 | termTimeFormat | time24h (1)
6 | termDateFormat | ddmmyyyy (1)
7 | termDateTime | 2013-9-12,19:25:19.0
8 | termEthController1IpAddress | 173.10.10.1
9 | termEthController1SubnetMask | 255.255.0.0
10 | termEthController1Gateway | 0.0.0.0
11 | termRfNwkPanId | CAFE
12 | termRfNwkRadius | 1
13 | termInbandManagementEnabled | true (1)
14 | termInbandManagementTimeoutSec | 10
15 | termRfNwkRepeaterProximity | noRepeater (0)
```

```
MPA APRISASR-MIB-4RF >>set termEthController1IpAddress 173.10.10.1
termEthController1IpAddress = 173.10.10.1

MPA APRISASR-MIB-4RF >>
```

Connected 0:06:07    ANSIW    38400 8-N-1    SCROLL    CAPS    NUM    Capture    Print echo

## 8. In-Service Commissioning

### Before You Start

When you have finished installing the hardware, RF and the traffic interface cabling, the system is ready to be commissioned. Commissioning the radio is a simple process and consists of:

1. Powering up the radios.
2. Configuring all radios in the network using SuperVisor.
3. Aligning the antennas.
4. Testing that the links are operating correctly.
5. Connecting up the client or user interfaces.

### What You Will Need

- Appropriately qualified commissioning staff at both ends of each link.
- Safety equipment appropriate for the antenna location at both ends of each link.
- Communication equipment, that is, mobile phones or two-way radios.
- SuperVisor software running on an appropriate laptop, computer, or workstation at the base station radio.
- Tools to facilitate loosening and re-tightening the antenna pan and tilt adjusters.
- Predicted receiver input levels and fade margin figures from the radio link budget.

## Antenna Alignment

A base station omni-directional collinear antenna has a vertical polarization. The remote station yagi antennas must also have vertical polarization.

### Aligning the Antennas

Align the remote station yagi antennas by making small adjustments while monitoring the RSSI. The Aprisa SRi has a Test Mode which presents a real time visual display of the RSSI on the front panel LEDs. This can be used to adjust the antenna for optimum signal strength (see 'Test Mode' on page 39).

---

**Note:** Low gain antennas need less adjustment in elevation as they are simply aimed at the horizon. They should always be panned horizontally to find the peak signal.

---

1. Press and hold the TEST button on the radio LED panel until all the LEDs flash green (about 3 - 5 seconds).

---

**Note:** The time for the LEDs to display the RSSI result is variable, depending on the network traffic, and can be up to 5 seconds. Small antenna adjustments should be made and then wait for the display to refresh.

---

2. Move the antenna through a complete sweep horizontally (pan). Note down the RSSI reading for all the peaks in RSSI that you discover in the pan.
3. Move the antenna to the position corresponding to the maximum RSSI value obtained during the pan. Move the antenna horizontally slightly to each side of this maximum to find the two points where the RSSI drops slightly.
4. Move the antenna halfway between these two points and tighten the clamp.
5. If the antenna has an elevation adjustment, move the antenna through a complete sweep (tilt) vertically. Note down the RSSI reading for all the peaks in RSSI that you discover in the tilt.
6. Move the antenna to the position corresponding to the maximum RSSI value obtained during the tilt. Move the antenna slightly up and then down from the maximum to find the two points where the RSSI drops slightly.
7. Move the antenna halfway between these two points and tighten the clamp.
8. Recheck the pan (steps 2-4) and tighten all the clamps firmly.
9. To exit Test Mode, press and hold the TEST button until all the LEDs flash red (about 3 - 5 seconds).

## 9. Product Options

### Country Specific Products

The standard Aprisa SRi provides product option part numbers for the following country compliance bodies;

#### APSI-N915-050-SO-21-C1AA

Country	Compliance Body
United States Of America	FCC
Canada	IC

#### APSI-N915-050-SO-21-C2AA

Country	Compliance Body
Australia	ACMA
New Zealand	R-NZ

## USB Serial Ports

### USB RS-232 / RS-485 Serial Port

The Aprisa SRi USB host port is predominantly used for software upgrade and diagnostic reporting. However, it can also be used to provide an additional RS-232 DCE or RS-485 serial port for customer traffic.

This is accomplished with a USB to RS-232 / RS-485 serial converter cable. This plugs into the USB host port  connector and can be terminated with the required customer connector.

This additional RS-232 / RS-485 serial port is enabled with the SuperVisor mode setting in Serial Port Settings (see 'Serial > Port Setup' on page 108).

The Aprisa SRi USB port has driver support for these USB serial converters. Other USB serial converters may not operate correctly.

### USB RS-232 / RS-485 operation

The USB serial converter buffers the received data frames into 64 byte blocks separated by a small inter-frame gap.

For the majority of applications, this fragmentation of egress frames is not an issue. However, there are some applications that may be sensitive to the inter-frame gap, therefore, these applications need consideration.

A 5 ms inter-frame is recommended for the applications that are sensitive to inter-frame gap timings.

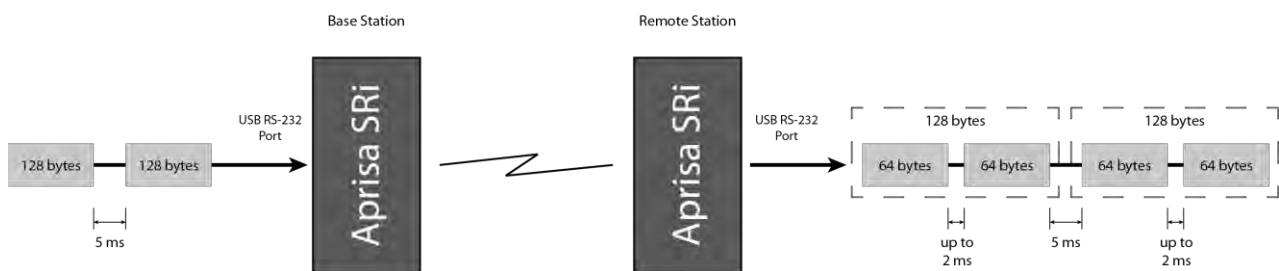

On a USB RS-232 port, Modbus RTU can operate up to 9600 bit/s with all packet sizes and up to 115200 bit/s if the packet size is less than 64 bytes. The standard RS-232 port is fully compatible with Modbus RTU at all baud rates.

## USB RS-232 Cabling Options

The following converter cables are available as Aprisa SRi accessories to provide the customer interface. The kit contains a USB connector retention clip (see ‘USB Retention Clip’ on page 263).

1. USB Converter to 1.8 metre multi-strand cable 6 wire for termination of customer connector

Part Number	Part Description
APSB-KFCA-USB-23-MS-18	4RF SRi Acc, Kit, Interface, USB Conv, RS-232, Multi-strand, 1.8m



2. USB converter to RJ45 female kit for USB to RS-232 DCE conversion.

Part Number	Part Description
APSB-KFCA-USB-23-45-MF18	4RF SRi Acc, Kit, Interface, USB Conv, RS-232, RJ45, Female, 1.8m

3. USB converter to DB9 female kit for USB to RS-232 DCE conversion.

Part Number	Part Description
APSB-KFCA-USB-23-D9-MF18	4RF SRi Acc, Kit, Interface, USB Conv, RS-232, DB9, Female, 1.8m

## USB RS-485 Cabling Options

The following converter cable is available as an Aprisa SRi accessory to provide the customer interface RS-485 2 wire. The kit contains a USB connector retention clip (see ‘USB Retention Clip’ on page 263).

1. USB Converter to 1.8 metre multi-strand cable 6 wire for termination of customer interface

Part Number	Part Description
APSB-KFCA-USB-48-MS-18	4RF SRi Acc, Kit, Interface, USB Conv, RS-485, Multi-strand, 1.8m





## USB Retention Clip

The USB Retention Clip attaches to the underside of the Aprisa SRi enclosure adjacent to the USB connector.



### To attach the USB Retention Clip:

1. Clean the enclosure surface where the retention clip will attach with an alcohol based cleaner e.g. Isopropanol.
2. Peel off the retention clip protective backing.
3. Stick the clip onto the Aprisa SRi enclosure ensuring that it aligns to the middle of the radio USB connector.



## 10. Maintenance

### No User-Serviceable Components

Except for fuse replacement, there are no user-serviceable components within the radio.

All hardware maintenance must be completed by 4RF or an authorized service centre.

Do not attempt to carry out repairs to any boards or parts.

Return all faulty radios to 4RF or an authorized service centre.

For more information on maintenance and training, please contact 4RF Customer Services at [support@4rf.com](mailto:support@4rf.com).

---

**CAUTION:** Electro Static Discharge (ESD) can damage or destroy the sensitive electrical components in the radio.

---

## Software Upgrade

A software upgrade can be performed on a single Aprisa SRi radio or an entire Aprisa SRi network.

### Network Software Upgrade

This process allows customers to upgrade their Aprisa SRi network from the central base station location without need for visiting remote sites.

The Software Pack is loaded into the base station with the file transfer process (see ‘Software > File Transfer’ on page 212) and distributed via the radio link to all remote stations.

When all remote stations receive the Software Pack version, the software can be remotely activated on all remote stations.

#### To upgrade the entire Aprisa SRi network software:

1. Using File Transfer, load the software pack into the base station (see ‘Software > File Transfer’ on page 212). The software can be transferred to the radio via an FTP transfer or from a USB flash drive.

The Aprisa SRi network file transfer operation is indicated in base station and remote stations by a flashing orange AUX LED.

2. Distribute the software to the entire network of remote radios (see ‘Software > Remote Distribution’ on page 220). Note that the distribution process over the air will take some time, depending on RF and Transfer rate settings.

The Aprisa SRi network software distribution operation is indicated in base station and remote stations by a flashing orange MODE LED.

---

**Note:** The distribution of software to remote stations does not stop customer traffic from being transferred. However, due to the volume of traffic, the software distribution process may affect customer traffic.

Software distribution traffic is classified as ‘management traffic’ but does not use the Ethernet management priority setting. Software distribution traffic priority has a fixed priority setting of ‘very low’.

---

3. Activate the software on the entire network of remote radios (see ‘Software > Remote Activation’ on page 222).

---

**Note:** When the new software activates on the remote radios, all link communication from the base station to the remote will be lost. The base station will attempt to re-establish connectivity to the remote radios for the new version verification but this will fail. However, when the new software activates on the remote radios, the remote radio will reboot automatically and link communication will restore when the base station software is activated.

---

When the Remote Activation process gets to the ‘Remote Radios On New Version’ step, don’t wait for this to complete but proceed to step 4.

4. Activate the software on the base station radio (see ‘Software > Manager’ on page 216).
5. When the new software has been activated, remote stations will re-register with the base station. The remote stations software version can be verified with ‘Network Status > Network Table’ on page 246.
6. When the base station restarts with the new software, rediscover the nodes (see ‘Discover Nodes’ on page 193).

7. Check that all remote radios are now running on the new software (see 'Network Status > Network Table' on page 246).

---

**Note:** The following steps will only be necessary if for some reason steps 1-7 did not operate correctly or if software activation is attempted before the distribution process ends or the remote radio was off during steps 1-7 and turns on later. Thus, the following steps will most likely not be required.

---

8. If step 7 shows that not all remote radios are running the latest software version, restore the base / master station to the previous software version (see 'Software > Manager' on page 216).
9. Attempt to re-establish connectivity to the remote radios that have failed to upgrade by navigating to and remotely managing the remote radios individually.
10. Navigate to the remote radio history log and review the logs to determine the reason for the failure to activate the new software version.
11. Take appropriate actions to address the reported issue. If connectivity restores with the failed remotes, repeat steps 2-7 if required.

## Single Radio Software Upgrade



This upgrade process is for upgrading the software on a single Aprisa SRi radio.

### File Transfer Method

The Software Pack is loaded into the radio with the file transfer process (see 'Software > File Transfer' on page 212) and activated (see 'Software > Manager' on page 216).

The Aprisa SRi upgrade operation is indicated by a flashing orange AUX LED.

#### To upgrade the Aprisa SRi radio software:

1. Unzip the software release files in to the root directory of a USB flash drive.
2. Insert the USB flash drive into the host port .
3. Using File Transfer, load the software pack into the radio (see 'Software > File Transfer' on page 212).
4. Remove the USB flash drive from the host port .
5. Activate the software on the radio (see 'Software > Manager' on page 216).

## USB Boot Upgrade Method

A single Aprisa SRi radio can also be upgraded simply by plugging a USB flash drive containing the new software into the USB A host port  on the Aprisa SRi front panel and power cycling the radio.

**To upgrade the Aprisa SRi radio software:**

1. Unzip the software release files in to the root directory of a USB flash drive.
2. Check that the SuperVisor USB Boot Upgrade setting is set to 'Load and Activate' (see 'Software > Setup' on page 211).
3. Power off the Aprisa SRi and insert the USB flash drive into the host port .
4. Power on the Aprisa SRi.
5. The software upgrade process is complete when the OK LED flashes green. This can take about 2 minutes.

The software will have loaded in to the radio current software version.

6. Remove the USB flash drive from the host port .
7. Power cycle the Aprisa SR.

Login to the radio being upgraded and go to SuperVisor 'Software > Manager' on page 216.

The version of the uploaded software will be displayed in the Software Pack 'Version' field and the current software version.

If the upgrade process did not start, the Aprisa SRi could already be operating on the version of software on the USB flash drive. This will be indicated by flashing OK LED and then the OK, MODE and AUX will light steady green.

If the radio is not operating on the new software (after the power cycle), it could be caused by the SuperVisor 'USB Boot Upgrade' setting set to 'Load Only' (see 'Software > Setup' on page 211).

In this case, go to SuperVisor see 'Software > Manager' on page 216 and tick the Software Pack 'Activate' checkbox and click 'Apply'.

If any Display Panel LED flashes red or is steady red during the upgrade process, it indicates that the upgrade has failed. This could be caused by incorrect files on the USB flash drive or a radio hardware failure.

## Software Downgrade

Radio software can also be downgraded if required. This may be required if a new radio is purchased for an existing network which is operating on an earlier software release.

The downgrade process is the same as the upgrade process.

# 11. Interface Connections

## RJ45 Connector Pin Assignments

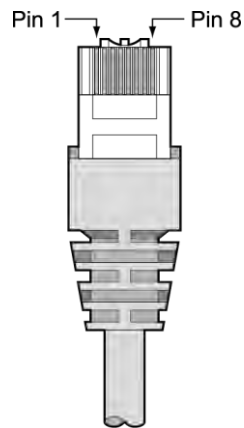

RJ45 pin numbering

## Ethernet Interface Connections

Pin Number	Pin Function	Direction	TIA-568A Wire Colour	TIA-568B Wire Colour
1	Transmit	Output	Green/white	Orange/white
2	Transmit	Output	Green	Orange
3	Receive	Input	Orange/white	Green/white
4	Not used		Blue	Blue
5	Not used		Blue/white	Blue/white
6	Receive	Input	Orange	Green
7	Not used		Brown/white	Brown/white
8	Not used		Brown	Brown

**Note:** The TIA-568B wiring is the most commonly used and matches the cables we supply.

RJ45 connector LED indicators		
LED	Status	Explanation
Green	On	Ethernet signal received
Orange	Flashing	Data traffic present on the interface

**Note:** Do not connect Power over Ethernet (PoE) connections to the Aprisa SRi Ethernet ports as this will damage the port.



# RS-232 Serial Interface Connections

## RS-232 Pinout

The Aprisa RS-232 Serial Interface is always configured as a DCE:

RJ45 Pin Number	Pin Function	Direction	TIA-568A Wire Colour	TIA-568B Wire Colour
1	RTS	Input	Green / white	Orange/white
2	DTR	Input	Green	Orange
3	TXD	Input	Orange / white	Green/white
4	Ground		Blue	Blue
5	DCD	Output	Blue / white	Blue/white
6	RXD	Output	Orange	Green
7	DSR	Output	Brown / white	Brown/white
8	CTS	Output	Brown	Brown

**Note:** The TIA-568B wiring is the most commonly used and matches the cables we supply.

## RS-232 Customer Cable Wiring

Aprisa RS-232 Interface - DCE			DTE Customer Interface		DCE Customer Interface	
RJ45 Pin Number	Pin Function	Direction	Pin Function	DB9 Male Pinout	Pin Function	DB9 Female Pinout
1	RTS	Input	RTS	7	CTS	8
2	DTR / Sleep Mode	Input	DTR	4	DSR	6
3	TXD	Input	TXD	3	RXD	2
4	Ground		Ground	5	Ground	5
5	DCD	Output	DCD	1		
6	RXD	Output	RXD	2	TXD	3
7	DSR	Output	DSR	6	DTR	4
8	CTS	Output	CTS	8	RTS	7

## RS-232 RJ45 LED Indicators

LED	Status	Explanation
Green	On	RS-232 device connected
Orange	Flashing	Data present on the interface

## Alarm Interface Connections

RJ45 Pin Number	Pin Function	Direction	TIA-568A Wire Colour	TIA-568B Wire Colour
1	Alarm 1 Input	Input	Green / white	Orange/white
2	Ground		Green	Orange
3	Alarm 2 Input	Input	Orange / white	Green/white
4	Ground		Blue	Blue
5	Alarm 1 Output / Sleep Mode	Output	Blue / white	Blue/white
6	Ground		Orange	Green
7	Alarm 2 Output	Output	Brown / white	Brown/white
8	Ground		Brown	Brown

---

**Note:** The TIA-568B wiring is the most commonly used and matches the cables we supply.

---

## 12. Alarm Types and Sources

### Alarm Types

There are three types of alarm event configuration types:

#### 1. Threshold Type

These alarm events have lower and upper limits. An alarm is raised if current reading is outside the limits.

---

**Note:** the limits for PA Current, TX AGC, TX Reverse Power and Thermal shutdown are not user configurable.

---

#### 2. Error Ratio Type

This is the ratio of bad packets vs total packets in the defined sample duration.

For Serial, it is the ratio of bad characters vs total characters in the duration seconds. An alarm is raised if current error ratio is greater than the configured ratio. The error ratio is configured in 'Upper Limit' field and accepts value between 0 and 1. Monitoring of these events can be disabled by setting the duration parameter to 0.

#### 3. Sample Duration Type

Used for No Receive data events type. An alarm is raised if no data is received in the defined sample duration. Monitoring of these events can be disabled by setting the duration parameter to 0.

See 'Events > Events Setup' on page 199 for setup of alarm thresholds / sample durations etc.

## Alarm Events

### Transmitter Alarm Events

Event ID	Event Display Text	Default Severity	Configuration Type	Function	Recommended Actions
1	PA Current	critical(1)	Threshold Type	Alarm to indicate that the current drawn by the transmitter power amplifier is outside defined limits.	Check antenna is not open or shorted, check duplexer correctly connected and tuned, if OK replace radio.
61	PA Driver Current	critical(1)	Threshold Type	Alarm to indicate that the current drawn by the transmitter power amplifier driver is outside defined limits.	Check antenna is not open or shorted, check duplexer correctly connected and tuned, if OK replace radio.
62	PA Stability	warning(4)	Threshold Type	Alarm to indicate that the power amplifier is oscillating which may cause corruption of the TX signal	Check antenna is not open or shorted, check duplexer correctly connected and tuned, if OK replace radio.
2	TX AGC	critical(1)	Threshold Type	Alarm to indicate that the variable gain control of the transmitter is outside defined limits.	Check antenna is not open or shorted, check duplexer correctly connected and tuned, if OK replace radio.
3	TX Reverse Power	warning(4)	Threshold Type	Alarm to indicate that the antenna is not connected to the radio	Check antenna is not open or shorted, check duplexer correctly connected and tuned, and confirm VSWR at TX port is less than 2:1. If OK replace radio.
60	TX Forward Power	warning(4)	Threshold Type	Alarm to indicate that the transmitter power is outside the selected TX power setting.	Check antenna is not open or shorted, check duplexer correctly connected and tuned, and confirm VSWR at TX port is less than 2:1. If OK replace radio.
4	Temperature Threshold	warning(4)	Threshold Type	Alarm to indicate that the transmitter temperature is outside defined limits.	Check ambient temperature and for airflow obstructions.
5	TX Synthesizer Not Locked	critical(1)	Threshold Type	Alarm to indicate that the transmitter synthesizer is not locked.	Power off radio and restart. If condition persists replace radio.
31	Thermal Shutdown	critical(1)	Threshold Type	Alarm to indicate that the transmitter has shutdown due to excessively high temperature.	Check ambient temperature and for airflow obstructions.

### Receiver Alarm Events

Event ID	Event Display Text	Default Severity	Configuration Type	Function	Recommended Actions
7	RSSI Threshold	warning(4)	Threshold Type	Alarm to indicate that the receiver RSSI reading taken on the last packet received is outside defined limits.	Check antenna is not open or shorted. If the antenna is directional check for off-pointing.
8	RX Synthesizer Not Locked	critical(1)	Not Configurable	Alarm to indicate that the receiver Synthesizer is not locked on the RF received signal.	Power off radio and restart. If condition persists replace radio.
9	RX CRC Errors	warning(4)	Error Ratio Type	Alarm to indicate that the data received on the RF path contains errors at a higher rate than the defined error rate threshold.	Check antenna is not open or shorted. Check duplexer is correctly tuned. If the antenna is directional check for off-pointing. Power off radio and restart. If condition persists replace radio.

## Radio Interface Path Alarm Events

Event ID	Event Display Text	Default Severity	Configuration Type	Function	Recommended Actions
34	RF No Receive Data	warning(4)	Sample Duration Type	Alarm to indicate that there is no data received on the RF path in the defined duration period.	Check master is operational. If new deployment check set-up, frequencies, and duplexer (if used). Check antenna is not open or shorted. If the antenna is directional check for off-pointing. Power off radio and restart. If condition persists replace radio.

## Modem Alarm Events

Event ID	Event Display Text	Default Severity	Configuration Type	Function	Recommended Actions
68	Modem FEC disable	warning(4)	Not Configurable	Alarm to indicate that FEC has been disabled. This could be a permanent event or a timed event.	Alarm to indicate that FEC has been disabled. This could be a permanent event or a timed event.
70	Modem ACM locked	warning(4)	Not Configurable	Alarm to indicate that the ACM has been locked to a fixed coding and modulation. This could be a permanent event or a timed event.	Alarm to indicate that the ACM has been locked to a fixed coding and modulation. This could be a permanent event or a timed event.

## Customer Equipment Interface Path Alarm Events

Event ID	Event Display Text	Default Severity	Configuration Type	Function	Recommended Actions
10	Port 1 Eth No Receive Data	warning(4)	Sample Duration Type	Alarm to indicate that Ethernet port 1 has no received input signal in the defined duration period.	Check Ethernet cable and connector. Check switch port or RTU is active. Check IP and VLAN configuration.
11	Port 1 Eth Data Receive Errors	warning(4)	Error Ratio Type	Alarm to indicate that Ethernet port 1 received input signal contains errors at a higher rate than the defined error rate threshold.	Check Ethernet cable and connector. Check switch port or RTU is active. Check IP and VLAN configuration.
12	Port 1 Eth Data Transmit Errors	warning(4)	Error Ratio Type	Alarm to indicate that Ethernet port 1 transmitted output signal contains errors at a higher rate than the defined error rate threshold.	Check Ethernet cable and connector. Check switch port or RTU is active. Check IP and VLAN configuration.
35	Port 2 Eth No Receive Data	warning(4)	Sample Duration Type	Alarm to indicate that Ethernet port 2 has no received input signal in the defined duration period.	Check Ethernet cable and connector. Check switch port or RTU is active. Check IP and VLAN configuration.
36	Port 2 Eth Data Receive Errors	warning(4)	Error Ratio Type	Alarm to indicate that Ethernet port 2 received input signal contains errors at a higher rate than the defined error rate threshold.	Check Ethernet cable and connector. Check switch port or RTU is active. Check IP and VLAN configuration.
37	Port 2 Eth Data Transmit Errors	warning(4)	Error Ratio Type	Alarm to indicate that Ethernet port 2 transmitted output signal contains errors at a higher rate than the defined error rate threshold.	Check Ethernet cable and connector. Check switch port or RTU is active. Check IP and VLAN configuration.
44	Port 3 Eth No Receive Data	warning(4)	Sample Duration Type	Alarm to indicate that Ethernet port 3 has no received input signal in the defined duration period.	Check Ethernet cable and connector. Check switch port or RTU is active. Check IP and VLAN configuration.

Event ID	Event Display Text	Default Severity	Configuration Type	Function	Recommended Actions
45	Port 3 Eth Data Receive Errors	warning(4)	Error Ratio Type	Alarm to indicate that Ethernet port 3 received input signal contains errors at a higher rate than the defined error rate threshold.	Check Ethernet cable and connector. Check switch port or RTU is active. Check IP and VLAN configuration.
46	Port 3 Eth Data Transmit Errors	warning(4)	Error Ratio Type	Alarm to indicate that Ethernet port 3 transmitted output signal contains errors at a higher rate than the defined error rate threshold.	Check Ethernet cable and connector. Check switch port or RTU is active. Check IP and VLAN configuration.
48	Port 4 Eth No Receive Data	warning(4)	Sample Duration Type	Alarm to indicate that Ethernet port 4 has no received input signal in the defined duration period.	Check Ethernet cable and connector. Check switch port or RTU is active. Check IP and VLAN configuration.
49	Port 4 Eth Data Receive Errors	warning(4)	Error Ratio Type	Alarm to indicate that Ethernet port 4 received input signal contains errors at a higher rate than the defined error rate threshold.	Check Ethernet cable and connector. Check switch port or RTU is active. Check IP and VLAN configuration.
50	Port 4 Eth Data Transmit Errors	warning(4)	Error Ratio Type	Alarm to indicate that Ethernet port 4 transmitted output signal contains errors at a higher rate than the defined error rate threshold.	Check Ethernet cable and connector. Check switch port or RTU is active. Check IP and VLAN configuration.
13	Port 1 Serial Data No Receive Data	warning(4)	Sample Duration Type	Alarm to indicate that the RS-232 port 1 has no received input signal in the defined duration period.	Check serial ports settings, check serial cable and connector.
14	Port 1 Serial Data Receive Errors	warning(4)	Error Ratio Type	Alarm to indicate that the RS-232 port 1 received input signal contains errors at a higher rate than the defined error rate threshold.	Check serial ports settings, check serial cable and connector.
52	Port 2 Serial Data No Receive Data	warning(4)	Sample Duration Type	Alarm to indicate that the RS-232 port 2 has no received input signal in the defined duration period.	Check serial ports settings, check serial cable and connector.
53	Port 2 Serial Data Receive Errors	warning(4)	Error Ratio Type	Alarm to indicate that the RS-232 port 2 received input signal contains errors at a higher rate than the defined error rate threshold.	Check serial ports settings, check serial cable and connector.
63	USB Port Serial Data No Receive Data	warning(4)	Sample Duration Type	Alarm to indicate that the USB port has no received input signal in the defined duration period.	Check serial ports settings, check USB serial cable and adapter, check serial connector.
64	USB Port Serial Data Receive Errors	warning(4)	Error Ratio Type	Alarm to indicate that the USB port received input signal contains errors at a higher rate than the defined error rate threshold.	Check serial ports settings, check USB serial cable and adapter, check serial connector.

### Component Failure Alarm Events

Event ID	Event Display Text	Default Severity	Configuration Type	Function	Recommended Actions
16	Component Failure	major(2)	Not Configurable	Alarm to indicate that a hardware component has failed.	Power off and restart radio. If fault persists replace radio.

## Hardware Alarm Events

Event ID	Event Display Text	Default Severity	Configuration Type	Function	Recommended Actions
56	VDC Power Supply	warning(4)	Not Configurable	Alarm to indicate that the input power source is outside the operating limits of 10 to 30 VDC	Check DC connection to radio. Replace power supply.
57	3.3 Volts Power Supply	warning(4)	Not Configurable	Alarm to indicate that the 3.3 volt power rail is outside defined limits.	Power off and restart radio. If fault persists replace radio.
58	5.0 Volts Power Supply	warning(4)	Not Configurable	Alarm to indicate that the 5.0 volt power rail is outside defined limits.	Power off and restart radio. If fault persists replace radio.
59	7.2 Volts Power Supply	warning(4)	Not Configurable	Alarm to indicate that the 7.2 volt power rail is outside defined limits.	Power off and restart radio. If fault persists replace radio.
71	15 Volts Power Supply	warning(4)	Not Configurable	Alarm to indicate that the 15 volt power rail is outside defined limits.	Power off and restart radio. If fault persists replace radio.

## Software Alarm Events

Event ID	Event Display Text	Default Severity	Configuration Type	Function	Recommended Actions
20	Calibration Failure	major(2)	Not Configurable	Alarm to indicate that the RF calibration has failed.	Power off and restart radio. If fault persists replace radio.
21	Configuration Not Supported	major(2)	Not Configurable	Alarm to indicate that a configuration has entered that is invalid.	Restore previous configuration, remove out of range or invalid parameters, updated software.
32	Network Configuration Warning	warning(4)	Not Configurable	Alarm to indicate a network configuration problem e.g. remote not registered.	Check for invalid parameters. Audit network settings.
73	Radio Network	warning(4)	Not Configurable	Alarm to indicate that there is an alarm in the radio network e.g. a remote radio has not registered or duplicate IP address.	Check for duplicate or invalid parameters. Audit network settings.
39	Software Restart Required	warning(4)	Not Configurable	Alarm to indicate that a configuration has changed that requires a software reboot.	Reboot radio.

## Hardware Alarm Input Alarm Events

Event ID	Event Display Text	Default Severity	Configuration Type	Function	Recommended Actions
24	Alarm Input 1	warning(4)	Not Configurable	Alarm to indicate that there is an active alarm on hardware alarm input 1	Action depends on nature of third-party alarm.
25	Alarm Input 2	warning(4)	Not Configurable	Alarm to indicate that there is an active alarm on hardware alarm input 2	Action depends on nature of third-party alarm.

## Informational Events

Event ID	Event Display Text	Default Severity	Function	Recommended Actions
26	User authentication succeeded	information (5)	Event to indicate that a user is successfully authenticated on the radio during login. The information on the user that was successfully authenticated is provided in the eventHistoryInfo object of the Event History Log.	Information No action required unless unexpected
27	User authentication failed	information (5)	Event to indicate that a user has failed to be authenticated on the radio during login. The information on the user that was unsuccessfully authenticated is provided in the eventHistoryInfo object of the Event History Log.	Check for possible intrusion attempt. If unexpected follow cyber incident report procedure.
28	Protection switch failed	information (5)	Event to indicate that a protection switch-over cannot occur for some reason. The reason for the failure to switch is described in the eventHistoryInfo object of the Event History Log.	Investigate reason for switch over and take remedial action.
29	Software System Check	information (5)	Event to indicate that the software has done a system check on the radio. Any information relevant to the cause of the event is provided in the eventHistoryInfo object of the Event History Log.	Information No action required unless unexpected
30	Software Start Up	information (5)	Event to indicate that the radio software has started. Any information relevant to the software start up is provided in the eventHistoryInfo object of the Event History Log.	Information No action required unless unexpected
33	Protection Switch Occurred	information (5)	Event to indicate that a protection switch-over occurs for some reason. The reason for the switch-over is described in the eventHistoryInfo object of the Event History Log.	Investigate reason for switch over and take remedial action.
41	File Transfer Activity	information (5)	Event to indicate that a data file is being transferred to or from the radio.	Information No action required unless unexpected
42	Software Management Activity	information (5)	Event to indicate that software is being distributed to remote radios.	Information No action required unless unexpected
43	Terminal Server TCP Activity	information (5)	Event to indicate TCP packets are being transferred from the terminal server.	Information No action required unless unexpected
55	Terminal Unit Information	information (5)	Event to indicate a miscellaneous activity occurring on the radio	Information no action required unless unexpected.
65	Event Action Activity	information (5)	Event to indicate an event action occurring on the radio	Information No action required unless unexpected
72	User SuperVisor Session Logout	information (5)	Event to indicate that a user has logged out or the user session has timed out	Information No action required unless unexpected



## 13. Specifications

### RF Specifications

Blocking (desensitization), intermodulation, spurious response rejection, and adjacent channel selectivity values determined according to the methods introduced in V1.7.1 of ETSI standards EN 300 113-1.

#### Frequency Bands

Compliance Body	Frequency Band	Frequency Range	Synthesizer Step Size
FCC	915 MHz	902-928 MHz	6.250 kHz
IC	915 MHz	902-928 MHz	6.250 kHz
ACMA	915 MHz	915-928 MHz	6.250 kHz
RSM	915 MHz	915-928 MHz	6.250 kHz

#### Channel Sizes

Minimum Coded Forward Error Correction

Channel Size	Gross Radio Capacity less FEC		
	64 QAM	16 QAM	QPSK
50 kHz	187.1 kbit/s	83.2 kbit/s	41.6 kbit/s

## Receiver

### Receiver Sensitivity

			50 kHz
BER < 10 <sup>-2</sup>	64 QAM	Min coded FEC	-98 dBm
BER < 10 <sup>-2</sup>	16 QAM	Min coded FEC	-106 dBm
BER < 10 <sup>-2</sup>	QPSK	Min coded FEC	-111 dBm
BER < 10 <sup>-6</sup>	64 QAM	Min coded FEC	-94 dBm
BER < 10 <sup>-6</sup>	16 QAM	Min coded FEC	-102 dBm
BER < 10 <sup>-6</sup>	QPSK	Min coded FEC	-107 dBm

### Adjacent Channel Selectivity

		50 kHz
Adjacent channel selectivity		> -37 dBm
BER < 10 <sup>-2</sup>	64 QAM	> 53 dB
BER < 10 <sup>-2</sup>	16 QAM	> 53 dB
BER < 10 <sup>-2</sup>	QPSK	> 58 dB

### Co-Channel Rejection

		50 kHz
BER < 10 <sup>-2</sup>	64 QAM	> -23 dB
BER < 10 <sup>-2</sup>	16 QAM	> -19 dB
BER < 10 <sup>-2</sup>	QPSK	> -12 dB

### Intermodulation Response Rejection

		50 kHz
Intermodulation response rejection		> -35 dBm
BER < 10 <sup>-2</sup>	64 QAM	> 55 dB
BER < 10 <sup>-2</sup>	16 QAM	> 55 dB
BER < 10 <sup>-2</sup>	QPSK	> 60 dB

### Blocking or Desensitization

		50 kHz
Blocking or desensitization		> -17 dBm
BER < 10 <sup>-2</sup>	64 QAM	> 73 dB
BER < 10 <sup>-2</sup>	16 QAM	> 73 dB
BER < 10 <sup>-2</sup>	QPSK	> 78 dB

### Spurious Response Rejection

		50 kHz
Spurious response rejection		> -32 dBm
BER < 10 <sup>-2</sup>	64 QAM	> 58 dB
BER < 10 <sup>-2</sup>	16 QAM	> 58 dB
BER < 10 <sup>-2</sup>	QPSK	> 63 dB

### Receiver Spurious Radiation

		50 kHz
Receiver spurious radiation		> -57 dBm

## Transmitter

Average Power output	64 QAM	0.005 to 0.2 W (+7 to +23 dBm, in 1 dB steps)
Note: The Peak Envelope Power (PEP) at maximum set power level is 1.0 W (+30 dBm).	16 QAM	0.006 to 0.25 W (+8 to +24 dBm, in 1 dB steps)
	QPSK	0.01 to 0.4 W (+10 to +26 dBm, in 1 dB steps)

Note: The Aprisa SRi transmitter contains power amplifier protection which allows the antenna to be disconnected from the antenna port without product damage.

Adjacent channel power	< - 60 dBc
Transient adjacent channel power	< - 60 dBc
Spurious emissions	< -20 dBc < -49 dBm 800 MHz to 915 MHz < -33 dBm 928 MHz to 1 GHz
Attack time	< 1.5 ms
Release time	< 0.5 ms
Data turnaround time	< 2 ms
Frequency stability	± 1.0 ppm
Frequency aging	< 1 ppm / annum

## Spread Spectrum

Number of standard hop zones	8 (non-overlapping)
Zone / channel selection	Zone selection list and channel black list
Hop Frequency	62.5 kHz
Minimum number of channels	50

### FCC / IC

Number of channels per hop zone	50
Full band option	400 channels full band single zone

### ACMA / RSM

Number of channels per hop zone	25
Full band option	200 channels full band single zone

## Modem

Forward Error Correction	Variable length concatenated Reed Solomon plus convolutional code
Adaptive Burst Support	Adaptive FEC Adaptive Coding and Modulation

## Data Payload Security

Data payload security	CCM* Counter with CBC-MAC
Data encryption	Counter Mode Encryption (CTR) using Advanced Encryption Standard (AES) 128, 192 or 256
Data authentication	Cipher Block Chaining Message Authentication Code (CBC-MAC) using Advanced Encryption Standard (AES) 128, 192 or 256

# Interface Specifications

## Ethernet Interface

The Aprisa SRi radio features an integrated 10Base-T/100Base-TX layer-2 Ethernet switch.

To simplify network setup, each port supports auto-negotiation and auto-sensing MDI/MDIX. Operators can select from the following preset modes:

- Auto negotiate
- 10Base-T half or full duplex
- 100Base-TX half or full duplex

The Ethernet ports are IEEE 802.3-compatible. The L2 Bridge (Switch) is IEEE 802.1d/q/p compatible, and supports VLANs and VLAN manipulation of add/remove VLANs.

<b>General</b>	Interface	RJ45 x 2 (Integrated 2-port switch)
	Cabling	CAT-5/6 UTP, supports auto MDIX (Standard Ethernet)
	Maximum line length	100 metres on cat-5 or better
	Bandwidth allocation	The Ethernet capacity maximum is determined by the available radio link capacity.
	Maximum transmission unit	Option setting of 1522 or 1536 octets
	Address table size	1024 MAC addresses
	Ethernet mode	10Base-T or 100Base-TX Full duplex or half duplex (Auto-negotiating and auto-sensing)
<b>Diagnostics</b>	Left Green LED	Off: no Ethernet signal received On: Ethernet signal received
	Right Orange LED	Off: no data present on the interface Flashing: data present on the interface

---

**Note:** Do not connect Power over Ethernet (PoE) connections to the Aprisa SRi Ethernet ports as this will damage the port.

---

## RS-232 Asynchronous Interface

The Aprisa SRi radio's ITU-T V.24 compliant RS-232 interface is configured as a Cisco® pinout DCE. The interface terminates to a DTE using a straight-through cable or to a DCE with a crossover cable (null modem).

The interface uses two handshaking control lines between the DTE and the DCE.

<b>General</b>	Interface	ITU-T V.24 / EIA/TIA RS-232E
	Interface direction	DCE only
	Maximum line length	10 metres (dependent on baud rate)
<b>Async parameters</b>	Standard mode data bits	7 or 8 bits
	Standard mode parity	Configurable for None, Even or Odd
	Standard mode stop bits	1 or 2 bits
	Interface baud rates	300, 600, 1200, 2400, 4800, 9600, 19200, 38400, 57600 and 115200 bit/s
<b>Control signals</b>	DCE to DTE	CTS, RTS, DSR, DTR
<b>Diagnostics</b>	Left Green LED	Off: no RS-232 device connected On: RS-232 device connected
	Right Orange LED	Off: no data present on the interface Flashing: data present on the interface

## Hardware Alarms Interface

The hardware alarms interface supports two alarm inputs and two alarms outputs.

### Alarm Inputs

The alarm connector provides two hardware alarm inputs for alarm transmission to the other radios in the network.

Interface	RJ45 connector
Detector type	Non-isolated ground referenced voltage detector
Detection voltage - on	> +10 VDC
Detection voltage - off	< +4 VDC
Maximum applied input voltage	30 VDC
Maximum input current limit	10 mA

### Alarm Outputs

The alarm connector provides two hardware alarm outputs for alarm reception from other radios in the network.

Interface	RJ45 connector
Output type	Non-isolated ground referenced open collector output
Maximum applied voltage	30 VDC
Maximum drive current	100 mA
Overload protection	Thermally resettable fuse



## Power Specifications

### Power Supply

Aprisa SRi Radio

Nominal voltage	+13.8 VDC (negative earth)
Absolute input voltage range	+10 to +30 VDC
Maximum power input	20 W
Connector	Molex 2 pin male screw fitting 39526-4002

### Power Consumption

---

Note: The radio power consumption is dependent on transmitter power, the type of traffic and network activity.

---

Aprisa SRi Radio

Mode	Transmit Peak Power	13.8 VDC
Transmit / Receive	1.0 W	< 20 W
Receive only		< 7 W

### Power Dissipation

Aprisa SRi Radio

Mode	Transmit Peak Power	13.8 VDC
Transmit / Receive	1.0 W	< 19 W
Receive only		< 7 W

## General Specifications

### Environmental

Operating temperature range	-40 to +70° C (-40 to +158° F)
Storage temperature range	-40 to +80° C (-40 to +176° F)
Operating humidity	Maximum 95% non-condensing
Acoustic noise emission	No audible noise emission

### Mechanical

#### Aprisa SRi Radio

Dimensions	Width 210 mm (8.27") Depth 130 mm (5.12") and 146 mm (5.748") with TNC connector Height 41.5 mm (1.63")
Weight	1.25 kg (2.81 lbs)
Colour	Matt black
Mounting	Wall (2 x M5 screws) Rack shelf (4 x M4 screws) DIN rail bracket

## Compliance

### FCC

Radio	FCC CFR47 Part 15.247
EMC	47CFR part 15 Radio Frequency Devices
Safety	EN 60950-1:2006 Class 1 division 2 for hazardous locations
Environmental	ETS 300 019 Class 3.4 Ingress Protection IP51

### IC

Radio	RSS-247
EMC	This Class A digital apparatus complies with Canadian standard ICES-003. Cet appareil numérique de la classe A est conforme à la norme NMB-003 du Canada.
Safety	EN 60950-1:2006 Class 1 division 2 for hazardous locations
Environmental	ETS 300 019 Class 3.4 Ingress Protection IP51

### ACMA

Radio	Radio Communications (Short Range Devices) Standard 2004
EMC	AS/NZS 4268
Safety	EN 60950-1:2006 Class 1 division 2 for hazardous locations
Environmental	ETS 300 019 Class 3.4 Ingress Protection IP51

### ACMA

Radio / EMC	AS/NZS 4268
Safety	EN 60950-1:2006 Class 1 division 2 for hazardous locations
Environmental	ETS 300 019 Class 3.4 Ingress Protection IP51

## 14. Product End Of Life

### End-of-Life Recycling Programme (WEEE)

The WEEE Directive concerns the recovery, reuse, and recycling of electronic and electrical equipment. Under the Directive, used equipment must be marked, collected separately, and disposed of properly.

4RF has implemented an end-of-life recycling programme to manage the reuse, recycling, and recovery of waste in an environmentally safe manner using processes that comply with the WEEE Directive (EU Waste Electrical and Electronic Equipment 2002/96/EC).

#### The WEEE Symbol Explained



This symbol appears on Electrical and Electronic Equipment (EEE) as part of the WEEE (Waste EEE) directive. It means that the EEE may contain hazardous substances and must not be thrown away with municipal or other waste.

#### WEEE Must Be Collected Separately

You must not dispose of electrical and electronic waste with municipal and other waste. You must separate it from other waste and recycling so that it can be easily collected by the proper regional WEEE collection system in your area.

#### YOUR ROLE in the Recovery of WEEE

By separately collecting and properly disposing of WEEE, you are helping to reduce the amount of WEEE that enters the waste stream.

One of the aims of the WEEE directive is to divert EEE away from landfill and encourage recycling. Recycling EEE means that valuable resources such as metals and other materials (which require energy to source and manufacture) are not wasted. Also, the pollution associated with accessing new materials and manufacturing new products is reduced.

#### EEE Waste Impacts the Environment and Health

Electrical and electronic equipment (EEE) contains hazardous substances which have potential effects on the environment and human health. If you want environmental information on the Aprisa SRi radio, contact us (see page 15).

## 15. Copyrights



## 16. Abbreviations

AES	Advanced Encryption Standard	TCP/IP	Transmission Control Protocol/Internet Protocol
AGC	Automatic Gain Control	TCXO	Temperature Compensated Crystal Oscillator
BER	Bit Error Rate	TFTP	Trivial File Transfer Protocol
CBC	Cipher Block Chaining	TMR	Trunk Mobile Radio
CCM	Counter with CBC-MAC integrity	TX	Transmitter
DCE	Data Communications Equipment	UTP	Unshielded Twisted Pair
DTE	Data Radio Equipment	VAC	Volts AC
EMC	Electro-Magnetic Compatibility	VCO	Voltage Controlled Oscillator
EMI	Electro-Magnetic Interference	VDC	Volts DC
ESD	Electro-Static Discharge	WEEE	Waste Electrical and Electronic Equipment
ETSI	European Telecommunications Standards Institute		
FW	Firmware		
HW	Hardware		
IF	Intermediate Frequency		
IP	Internet Protocol		
I/O	Input/Output		
ISP	Internet Service Provider		
kbit/s	Kilobits per second		
kHz	Kilohertz		
LAN	Local Area Network		
LED	Light Emitting Diode		
mA	Milliamps		
MAC	Media Access Control		
MAC	Message Authentication Code		
Mbit/s	Megabits per second		
MHz	Megahertz		
MIB	Management Information Base		
MTBF	Mean Time Between Failures		
MTTR	Mean Time To Repair		
ms	milliseconds		
NMS	Network Management System		
PC	Personal Computer		
PCA	Printed Circuit Assembly		
PLL	Phase Locked Loop		
ppm	Parts Per Million		
PMR	Public Mobile Radio		
RF	Radio Frequency		
RoHS	Restriction of Hazardous Substances		
RSSI	Received Signal Strength Indication		
RX	Receiver		
SNMP	Simple Network Management Protocol		
SNR	Signal to Noise Ratio		
SWR	Standing Wave Ratio		

## 17. Index

		requirement for	16, 62
<b>A</b>			
access rights	169		
accessory kit	16		
antennas			
aligning	257		
installing	57		
selection and siting	47		
siting	49		
attenuators	45		
<b>B</b>			
bench setup	45		
<b>C</b>			
cabling			
accessory kit	16		
coaxial feeder	45, 50		
CD contents	16		
<b>E</b>			
earthing	45, 50, 52		
environmental requirements	51		
<b>F</b>			
feeder cables	50		
front panel			
connections	36		
<b>H</b>			
hardware			
accessory kit	16		
installing	57		
humidity	51		
<b>I</b>			
interface connections	268		
Ethernet	268		
RS-232 Serial	269, 270		
<b>J</b>			
Java			
<b>L</b>			
lightning protection	52		
linking system plan	50		
logging in			
SuperVisor	69		
logging out			
SuperVisor	70		
<b>M</b>			
maintenance summary	181		
mounting kit	16		
<b>O</b>			
operating temperature	51		
<b>P</b>			
passwords			
changing	170		
path planning	47		
path propagation calculator	47		
pinouts			
Ethernet	268		
RS-232 Serial	269, 270		
power supply	51		
<b>R</b>			
radio			
earthing	45, 52		
logging into	69		
logging out	70		
operating temperature	51		
rebooting	184		
storage temperature	51		
rebooting the radio	184		
RS-232			
serial data	106		
RS-232 Serial interface	105, 106, 112, 115		
interface connections for	269, 270		
port settings for	106		



**S**

security	
settings	160, 171, 176, 178, 195, 199, 201, 203, 205
summary	159, 173
security users	
user privileges	169
SuperVisor	
logging into	69
logging out	70
PC requirements for	62
PC settings for	65

**T**

temperature	51
tools	53

**U**

users	
adding	169
changing passwords	170
deleting	170
user details	169
user privilege	170

**W**

WEEE	288
------	-----