



CONSOLIDATED SEWING MACHINE CORP.

└ INDUSTRIAL SEWING & CUTTING EQUIPMENT

205RB

INSTRUCTION MANUAL

CONTENT

Operation Instruction

1. Main technical specifications	1
2. Operation preparation.....	1
3. Installing the motor.....	1
4. Connecting the clutch lever to the pedal.....	1
5. Installing belt guard	2
6. Installing the bobbin winder.....	2
7. Lubrication.....	2
8. Trial run	3
9. Hook oil amount adjustment	3
10. Oil pump supply adjustment	3
11. Installing the needle.....	4
12. Coordination among needle 、 thread and sewing materials.....	4
13. Threading the needle thread.....	4
14. Winding adjustment.....	5
15. Setting the stitch length and controlling the reverse sewing.....	6
16. Setting the position of presser bar.....	6
17. Adjusting the pressure of presser foot	6
18. Adjusting the thread tension	7
19. Adjusting the thread take-up spring	7
20. Adjusting the tension of needle thread and bobbin thread	8
21. Timing adjustment between the needle and the rotating hook.....	9
22. Installing and removing rotating hook.....	10
23. Installing feed dog.....	10
24. Feed dog horizontal adjustment	11
25. Stitch length error adjustment.....	11
26. Feed timing adjustment.....	12
27. Adjusting the tension releasing mechanism.....	13
28. Upper feed adjustment	14
29. Adjusting presser foot alternate lift mechanism.....	14
30. Adjusting the lift amount of presser foot with walking presser foot	15
31. Adjusting the clearance between presser foot and walking presser foot	15
32. Periodical cheaning.....	15~16

Parts Catalogue

1. Arm and bed	17~18
2. Arm shaft vertical shaft Needle bar and thread take-up	19~20
3. Feed dog lift and thread looping	21~22
4. Feed adjustment	23~24
5. Presser foot	25~26
6. Upper feed	27~28
7. Oil pump	29~30
8. Oil reservoir and accessories	31~32

1. Main technical specifications

Application: medium and heavy duty
(... heavy duty with thick thread)
Max sewing speed: 2000 spm (C... 1800 spm)
Stitch length: 0~8mm
Presser foot lift: 6.5mm by hand 13mm by knee
Max sewing capacity: 8mm
Alternate presser foot lift volume: 3.3~5.5mm
Timing feed length: not less than 8mm
Needle: Model DP×1720#~24#(C... DP×1725#)
Hook: Auto-lubricating big rotating hook
Lubrication: Auto lubrication
Motor power: 0.37kw

2. Preparation

(1) Cleaning machine

Clean off the grease and dusts on the surface of machine with gasoline and soft cloth.

(2) Inspection

Before use a thorough inspection should be done upon the machine. Turn balance wheel slowly to see if there is any obstacle, collision and uneven resistance between parts. If there is, adjustment should be done before operation.

3. Installing the motor(Fig.1)

Align machine balance wheel belt groove(A) with motor pulley belt groove(B) by moving the motor(C) leftward or rightward. Be sure the belt is not touch with table.

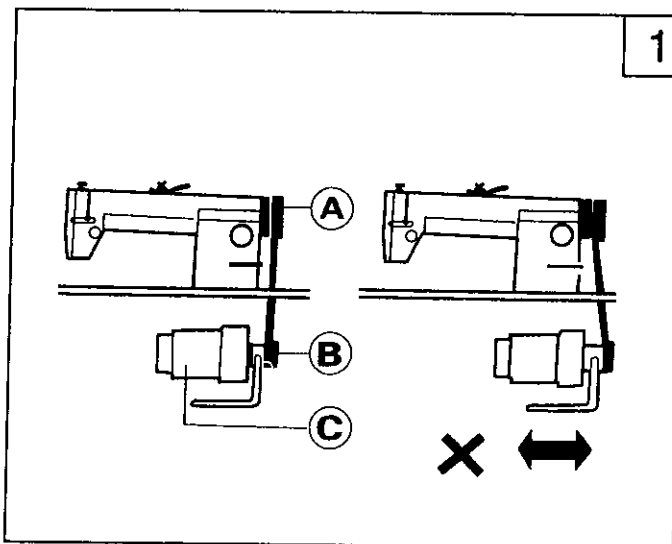

4. Connecting the clutch lever to the pedal(Fig.2)

a. The optimum tilt angle of pedal with floor is approx 15 degree.

b. Adjust the clutch of the motor so that clutch lever(C) and draw bar (B) run in line as Fig. 6, the machine would have stable motion and long using.

c. The machine balance wheel should rotate counter clockwise for normal sewing when view from opposite side of the balance wheel. The motor rotates in the same direction. The rotation can be reversed by reversing (turn over 180 deg.) the plug of the motor.

d. Adjust the tension of V-belt F by moving the motor vertically. The proper tension of V-belt is a slack of 10~12mm when the belt is depressed (at the belt pan) by finger.

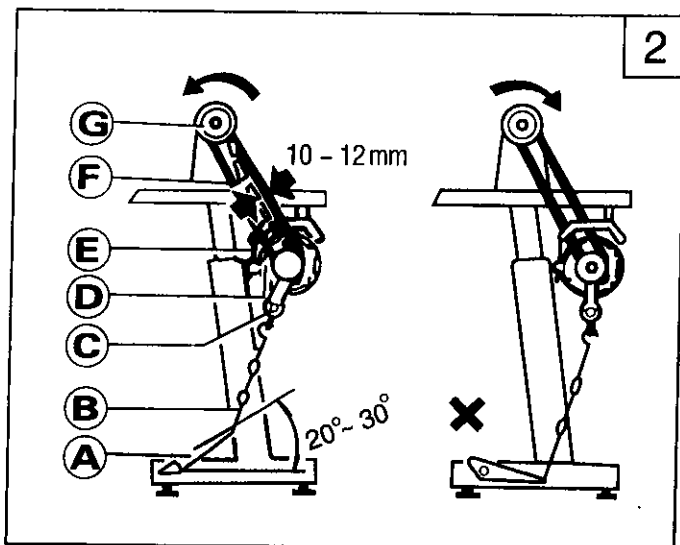

5. Installing belt guard(Fig 3)

The belt guard should be installed for safety.

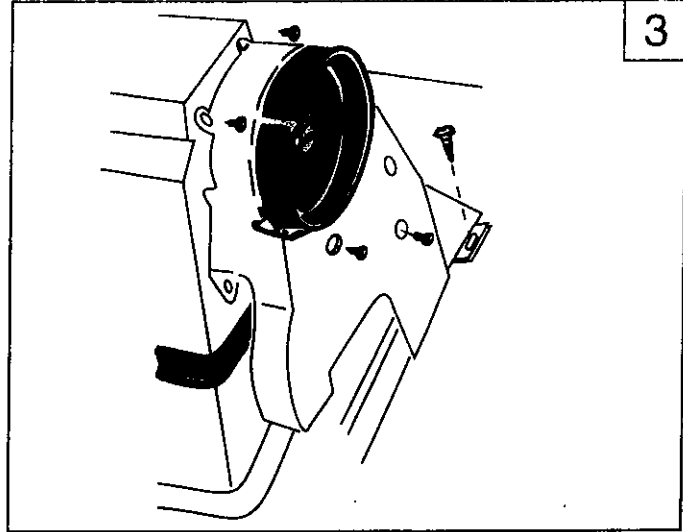

6. Installing the bobbin winder (Fig 4)

Align pulley (B) of the bobbin winder with the outside of the belt, and there should be a proper clearness between them, so that pulley (B) can be contacted with the belt when stop latch thumb lever (A) is depressed, thereby the belt drives pulley (B) while the machine running, the bobbin winder should be parallel with belt slit (E) of the table, then fasten with two wood screw (D).

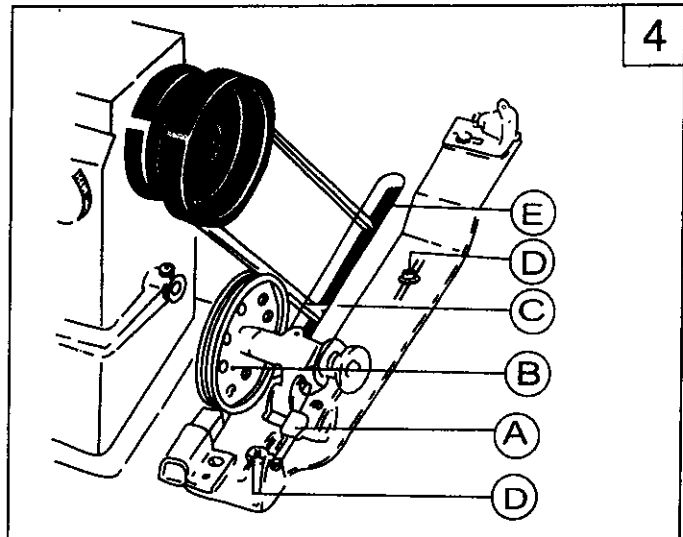

7. Lubrication (Fig 5)

A. Oil amount

Oil amount must be oiled according to the mark of drip pan. Mark (A) is the highest situation, Mark (B) is the lowest situation, Note that oil amount couldn't be lower than mark (B), otherwise all parts of machine will appear heat and dead point for not gaining oil.

b. Oiling

In lubrication, HA-8 sewing machine oil or HJ-7 machine oil must be used. Before running, the machine must be oiled at the mark (A).

c. Changing

Turn off the screw plugs (C), clean up the dirty oil and the dust of drip pan, then fasten the screw plugs (C), add fresh oil

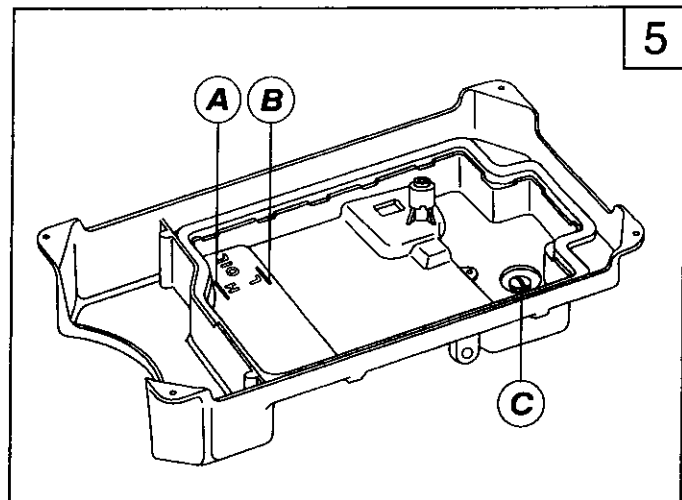

8. Trial run (Fig 6)

When the machine left out of operation for a quite long time and used again, remove the red rubber plug on top of the machine head, oil it thoroughly, the lift the presser foot and run at a low speed of 1000 ~ 1500spm, observe the sparking condition through oil window (c), as the lubrication is well, keep the running test at the low speed about 30 minutes, then increase the speed gradually, after months running to perfect its performance, then increase up to proper sewing speed.

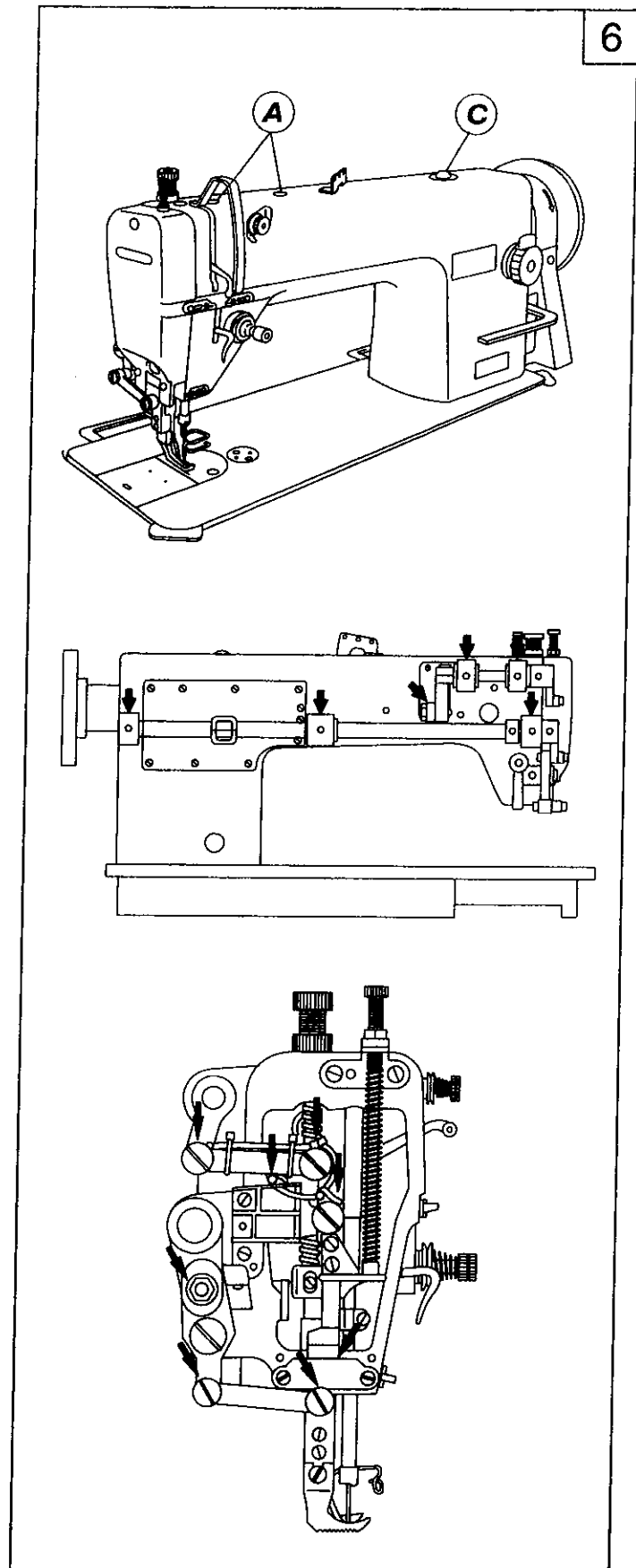

9. Rotating hook oil amount adjustment (Fig 7)

The hook oil amount can be adjusted by Screw (A). Turn it clockwise ("+") to increase amount; counter-clockwise ("-") to decrease. The oil amount is adjusted in the range of five turns of Screw(A): Tightening for more; Loosening for less.

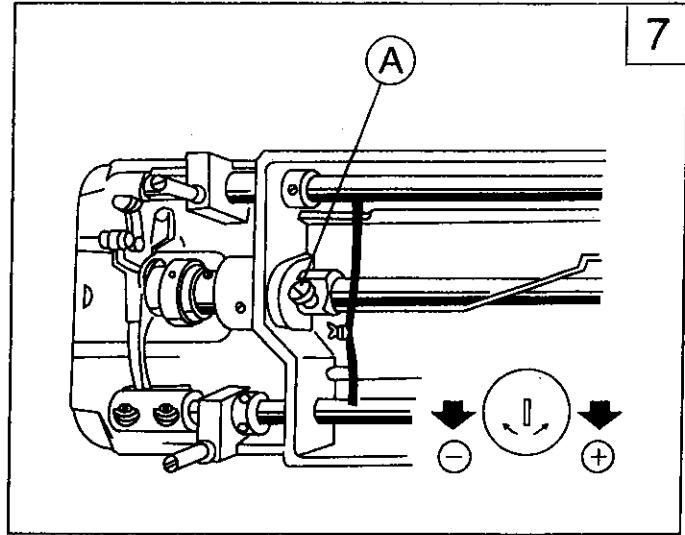

10. Oil pump supply adjustment (Fig 8)

Generally no adjustment is for oil pump. When the machine is running at a low speed, observe the oil screen. If no oil splashing, close the clearance.

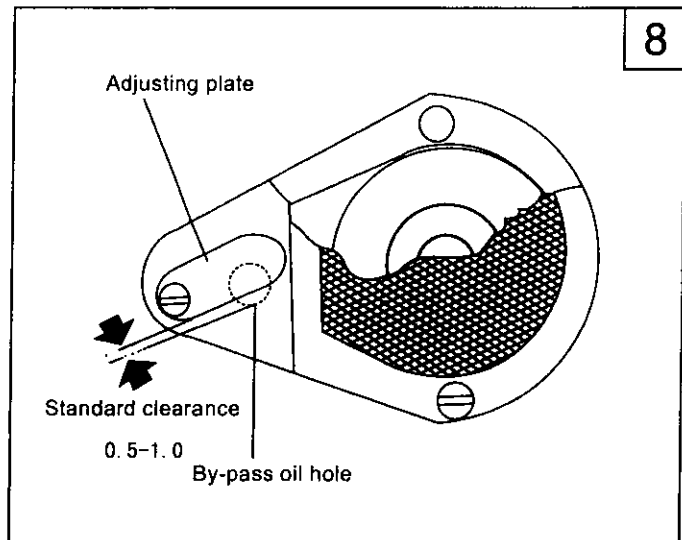

11. Installing the needle (Fig 9)

Turn the balance wheel to lift the needle bar to its highest point, loosen needle set screw 1, making the needle groove turn to the left side of an operator, fully insert the needle shank up to the bottom of needle socket, then tighten needle set screw 1.

Note: Fig.12(b) insufficient insertion

Fig.12(C) Wrong direction of groove

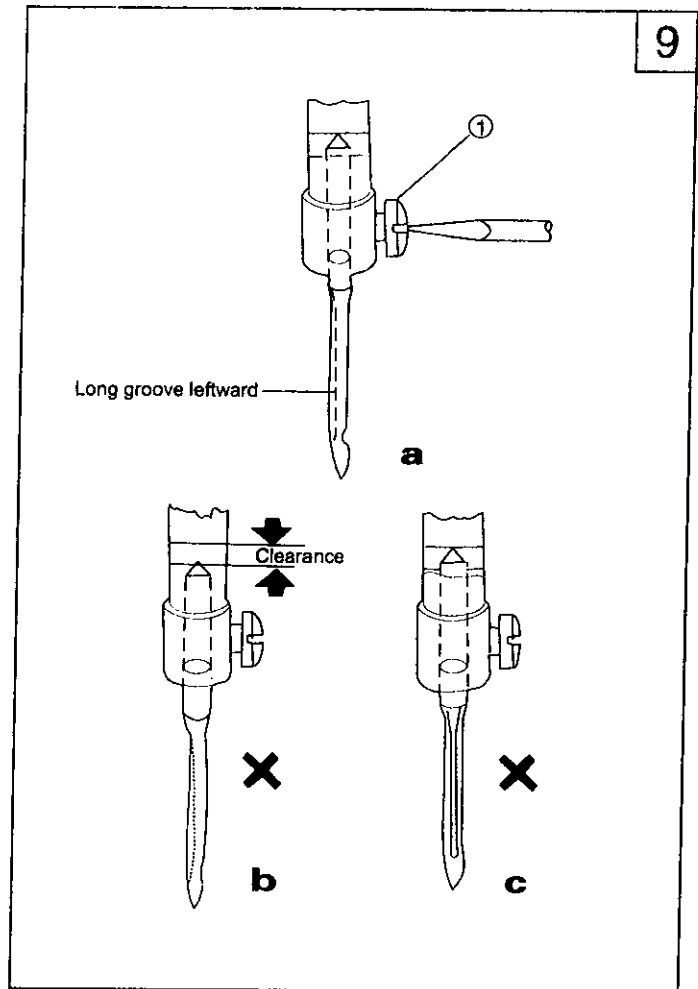

12. Coordination among the needle, the thread and the material (Fig 10)

The needle thread is left-twisted, the bobbin thread is left or right-twisted. Holding the thread, twist it with right hand in the direction of arrow shown in Fig 10, if it is tight, it is left-twisted, contrarily, it is right-twisted.

The Needle is DPX 17 20#~24# (DPX 17 25#), the needle number must be fitted for the materials. Sewing too heavy the weight of materials, the needle would be breaking and skipping stitch and thread breaking for its too thin, if the needle is too thick, it would damage the clothes for its large needle hole. Therefore, the selection of needle and thread must be fitted to the materials.

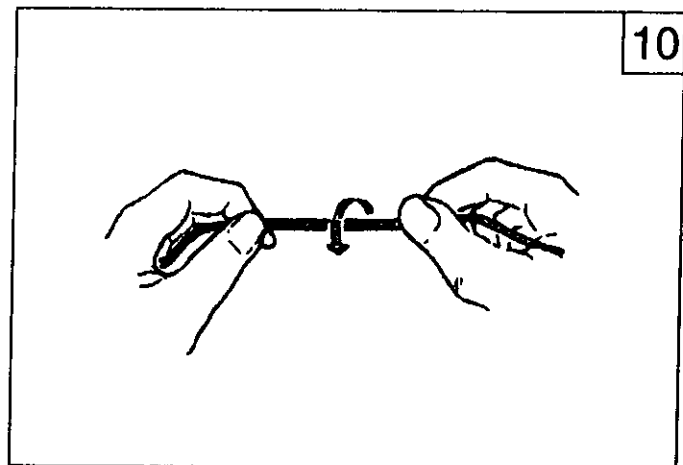

13. Threading the needle thread (Fig 11)

When threading the needle thread, raise the needle bar to its highest position, lead the thread from the spool and pass it in the order instructed.

(1) Lead the thread down through the three-eye thread guide① on the top.

(2) Pass down thru the left hole of thread retainer②, then down thru the lower hole of thread retainer②.

(3) Pass down thru between the two tension disc③

(4) Pass up thru the hook of thread take-up spring④, thru thread regulator ⑤, thru thread guide ⑥ and up thru the hole of thread take-up lever⑦.

(5) Down thru thread guide ⑧, ⑨, and needle bar thread guide ⑩, then pass the thread from the left thru the eye of needle⑪, draw out the thread approx 100mm from the needle eye.

When drawing the bobbin thread, hold the tip of the needle thread by hand, turn the balance wheel to lower the needle bar and then to lift it to its highest position. Pull the needle thread and then the bobbin thread is drawn up. put the tips of the needle and bobbin thread toward front under the presser foot.

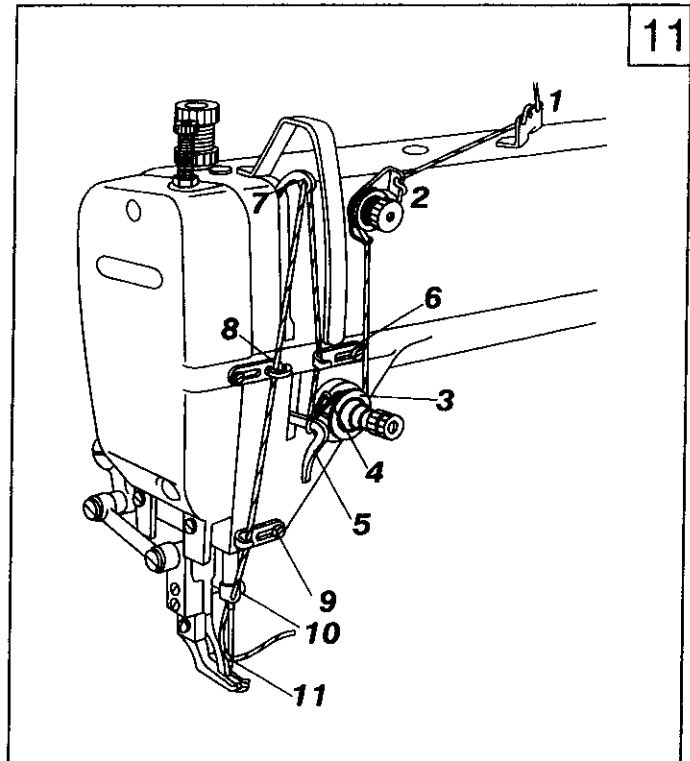

14. Winding adjustment (Fig 12)

The wound bobbin thread should be neat and tight. If not, adjust the thread tension by turning tension stud thumb nut of the bobbin winder tension bracket (A). If the wound bobbin is not neat, tension bracket (C) can be moved to be adjusted. When adjusting, loosen screw (B) first, then move the bracket leftward or rightward if the thread is wound to one side as shown in Fig.15(6), move the tension bracket rightward, while if the thread is wound to one side as shown in Fig.15(C), move the tension bracket leftward until the thread is wound neatly as shown in Fig.15(a), tighten screw (B).

Note: Nylon or polyester thread should be wound with light tension. otherwise bobbin (D) might be broken or deformed.

Don't overfill the bobbin, because it make its thread loosening down from the bobbin. The optimum capacity of thread will fill about 80% of bobbin outside diameter, and this can be adjusted by stop latch screw (E).

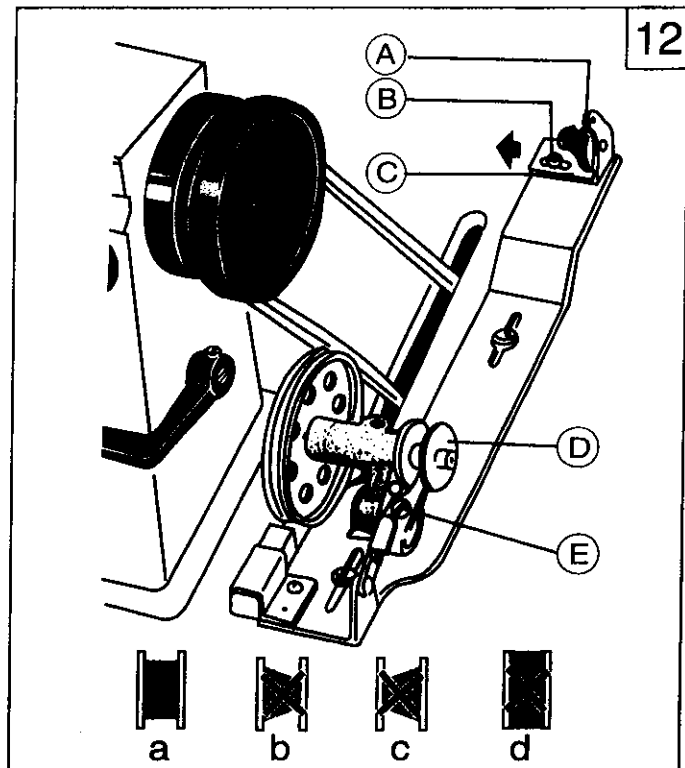

15. Setting the stitch length and controlling the reverse sewing (Fig 13)

Stitch length can be set by turning stitch length regulating dial(A). The figures on the stitch length regulation dial plate (B) indicate the stitch length.

Reverse sewing can be obtained when feed reverse lever(C) is depressed and forward sewing can be restored automatically when feed reverse lever (C) is released.

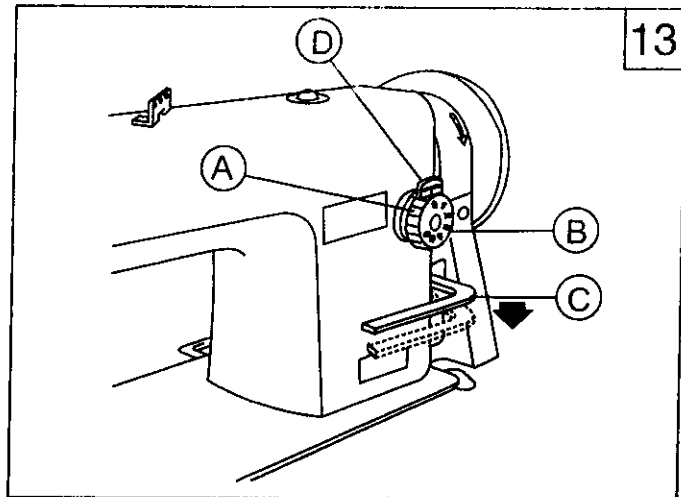

16. Thread take-up oiling (Fig 14)

Thread take-up section adopts woolen thread oiling. after long time of use, its function lost, so replace with a new one.

- ① Open the face plate, remove the pressure screw, lock nut and presser bar.
- ② Remove Hinge(A) and Lever(B)
- ③ Draw out Oil Wick(C).
- ④ Loosen the wick fix screw on the arm top, and take out Set Plate(D).
- ⑤ Replace with a new one.
- ⑥ Installing is a reverse sequence.

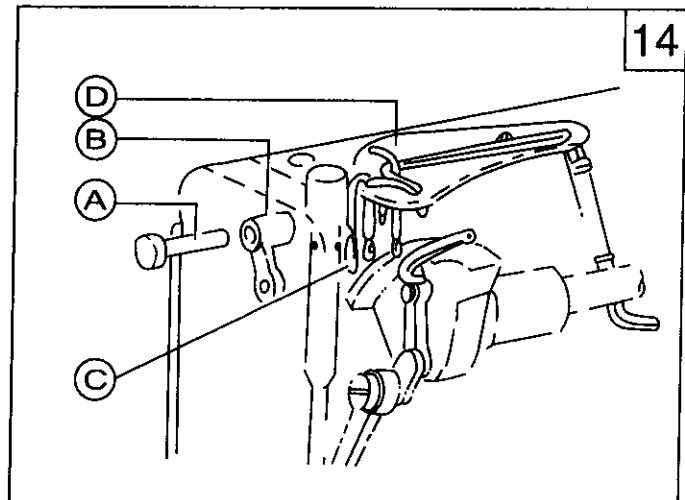

17. Adjusting the pressure of presser foot (Fig 15.)

Pressure on presser foot is to be adjusted in accordance with materials to be sewn. Loosen lock nut(A). If heavy materials to be sewn, turn pressure regulating thumb screw clockwise as shown Fig.20 (a) to increase the pressure. While light materials to be sewn, turn the pressure regulating thumb screw counter clockwise as shown in Fig. 20 (b) to decrease the pressure on presser foot, then tighten lock nut (A).

The pressure of presser foot is proper as the sewing materials can be fed normally.

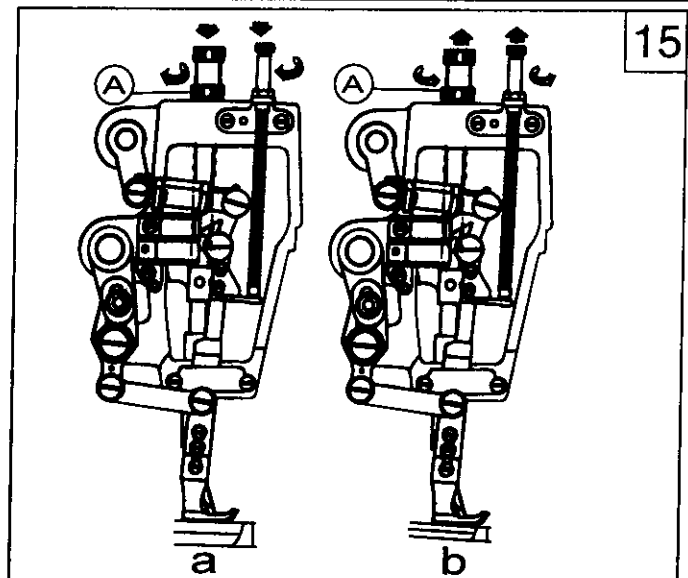

18. Adjusting the thread tension (Fig 16, 17)

In general, the thread tension is to be adjusted in accordance with materials thread and others.

In practice, the thread tension is adjusted according to the stitches resulted to get the normal stitches.

When adjusting the bobbin thread tension, turn bobbin case tension spring screw (A) clockwise for more tension or turn the screw counter clockwise for less tension.

It is a common practice to check the bobbin thread tension. In case of polyester thread 50=, hold the end of the thread. If the bobbin case falls down slowly, the proper tension is obtained.

The needle thread tension should be adjusted with reference to the bobbin thread tension. The needle thread tension can be adjusted by changing tension of the thread take-up spring, sewing range of the thread take-up spring, tension of tension disc, and the position of thread guide.

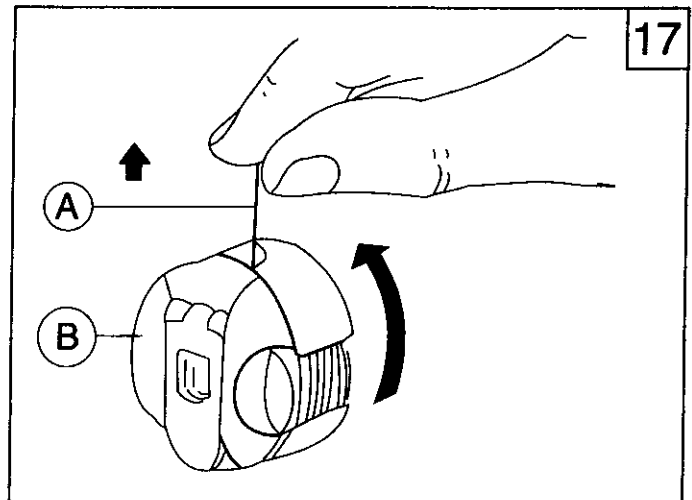
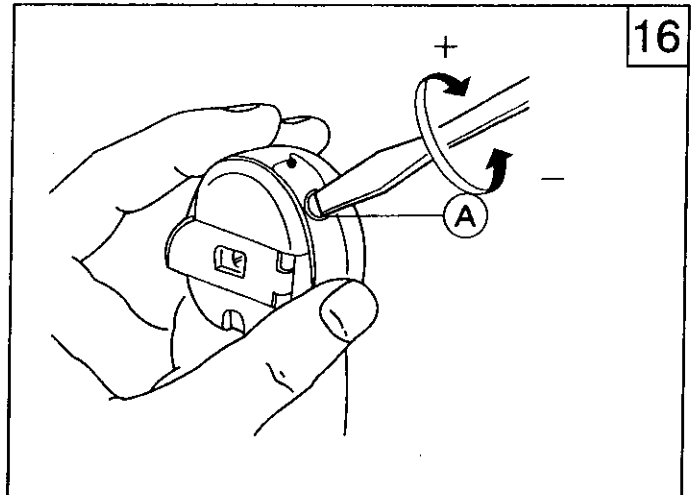

19. Adjusting the thread take-up spring (Fig 18, 19)

The normal sewing range of thread take-up spring is 5~8mm. For sewing light weight materials(short stitch), weaken the spring tension and widen the sewing range of spring, while for sewing heavy weight materials, strengthen the spring tension and shorten the sewing range of spring .

1) Adjusting the thread take-up spring tension (Fig.18) .

Loosen tension stud set screw (A), turn tension stud (B) clockwise to make the spring get more tension, or turn the tension stud counter clockwise to make the spring get less tension, After adjustment, Be sure to tight tension stud set screw (A).

The method of adjustment:

Loose set screw (A) first, then to turn tension stud(B) counter clockwise to release the tension of

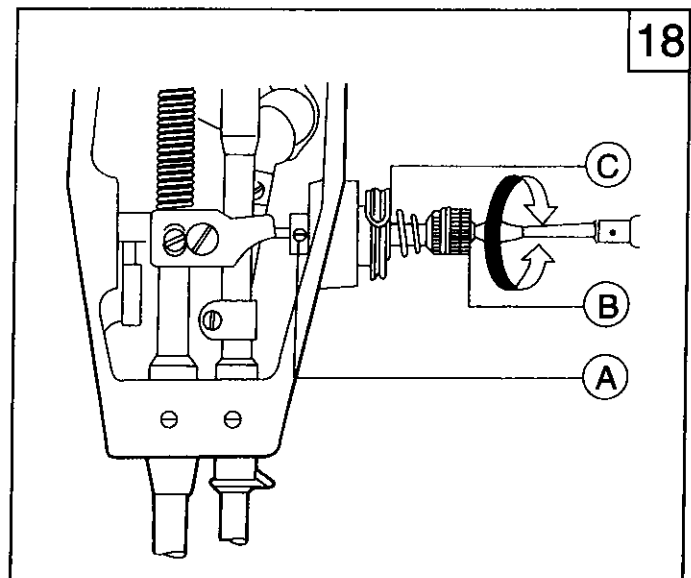

thread take-up spring(C) to zero, and to turn tension stud (B) clockwise until spring (C) just comes into contact with the stop slot on the thread take-up spring regulator, then to further turn tension stud (B) counter-clockwise by 1/2 turn After adjustment, tighten tension stud set screw (A).

2) Adjusting the sewing range of thread take-up spring (Fig 19)

Loosen set screw (B), turn tension complete (C) clockwise to increase the sewing range or turn tension complete (C) counter clockwise to decrease the sewing range.

Before delivery, the thread take-up spring is properly adjusted, Readjustment is needle only in the case of sewing special materials or with special thread.

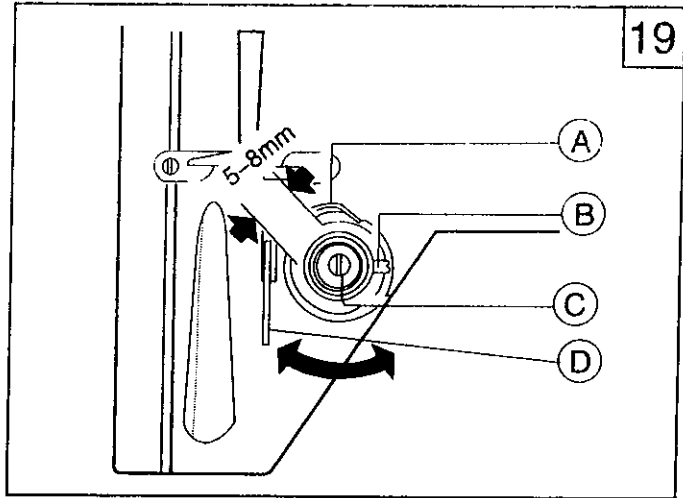

20. Adjusting the tension of needle thread & bobbin thread (Fig20, 21, 22)

The position of the thread guide affects sewing quality, so it must be adjusted according to the materials to be sewn.



	Leftward	Center	Rightward
Thread guide position			
Material	Heavy	Medium	Light

Fig.20 shows the various type of stitch forms.

Normal stitch form should be as shown in Fig.20(a). When abnormal stitches occur with pucker ring or thread breakage, the tension of needle thread and bobbin thread must be adjusted accordingly

(a) The needle thread tension is too strong or the bobbin thread tension is too weak. turn the tension regulating thumb nut counter clockwise to make the needle thread get less tension or tighten the bobbin case tension regulating screw with small plastic screw driver to make the bobbin thread get more tension(Fig.21).

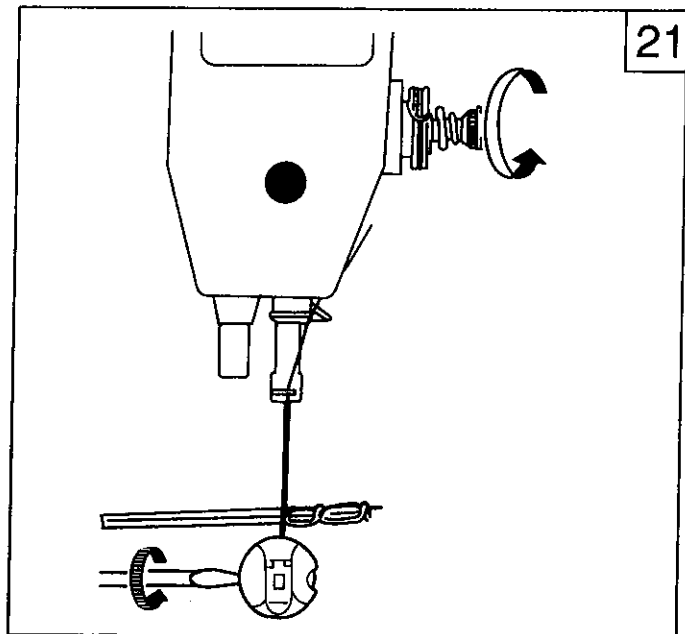
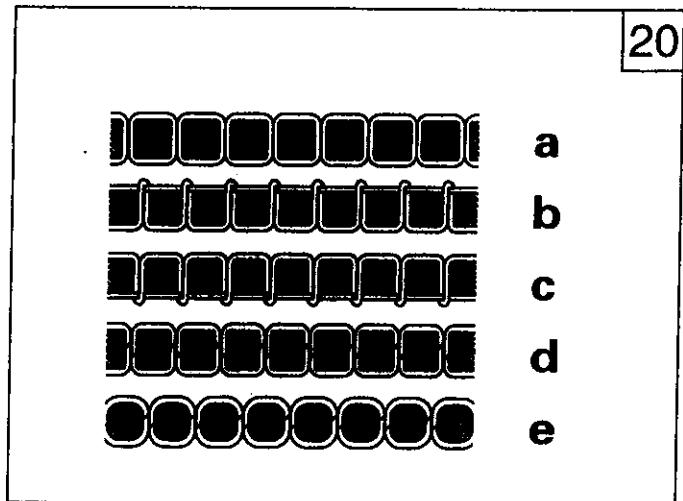

(B) The needle thread tension is too weak or the bobbin thread is too strong, turn the tension regulating thumb nut clockwise to make the needle thread get more tension or turn the bobbin case tension regulating screw counter clockwise with small plastic screw driver to make the bobbin thread get less tension (Fig.22)

(c) Other abnormal stitches as shown in Fig.20 (d),(e), adjustment can be made which reference to the above methods.

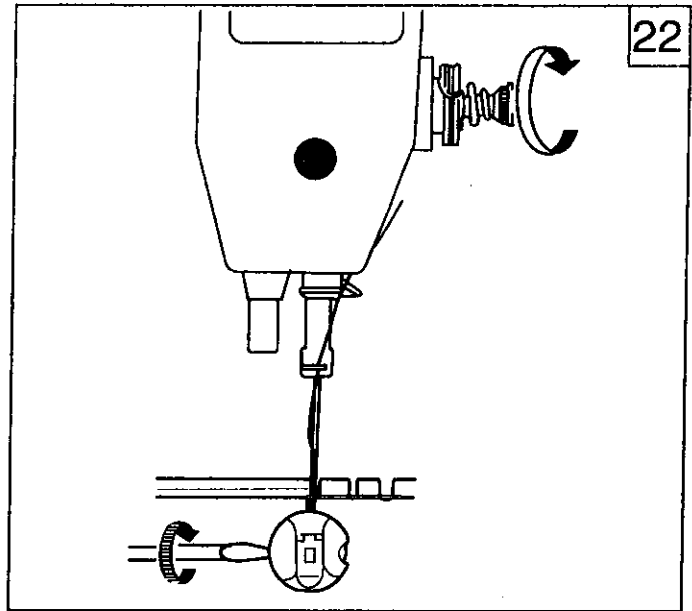

21. Timing between the needle and the rotating hook (Fig.23, 24, 25, 26)

1 Adjusting the position of needle bar

Turn the balance wheel to locate the needle bar (C) at its lowest position, remove the rubber plug in the face plate (A), then loosen the needle bar (C) connecting stud clamping screw (B) and move the needle bar (C) vertically to locate the timing position (The timing position of the needle bar is: when the needle bar at its lowest position, the center of needle eye (D) coincide with inside surface (E) of bobbin case holder as shown in Fig.24). Tighten clamping screw (B), plug the rubber plug.

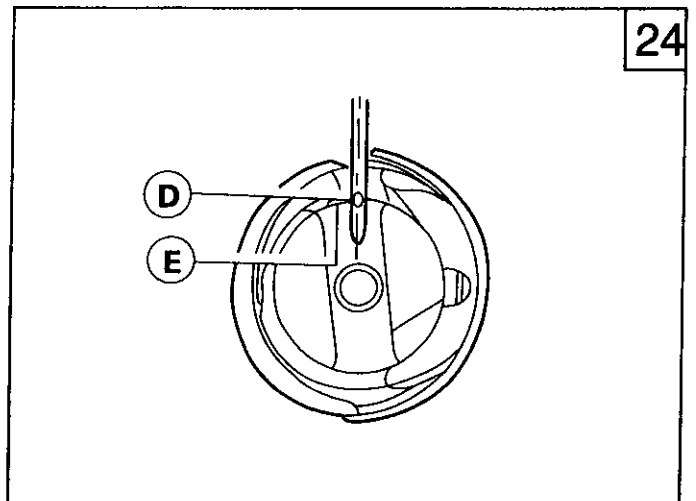
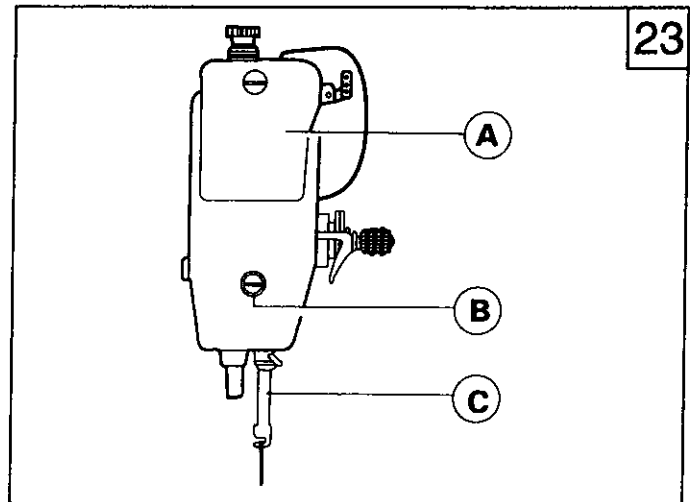

2. Adjusting rotating hook point timing with needle.

The motive relation between rotating rotating and needle affects the sewing quality. Standard timing relation is: turn the balance wheel to locate needle bar to its lowest position, and lift back 2.5 mm the rotating hook point(D) should be coincides with needle center line (C), and hook point (D) is 1.2mm above the upper edge(E) of needle eye.

When adjusting the rotating hook point timing also to note the clearance between notch bottom of needle(D) and hook point(C) of approx 0.05mm must be maintained. (Fig 26)

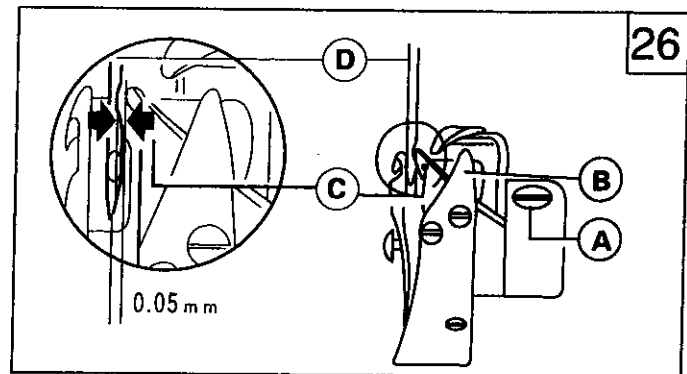
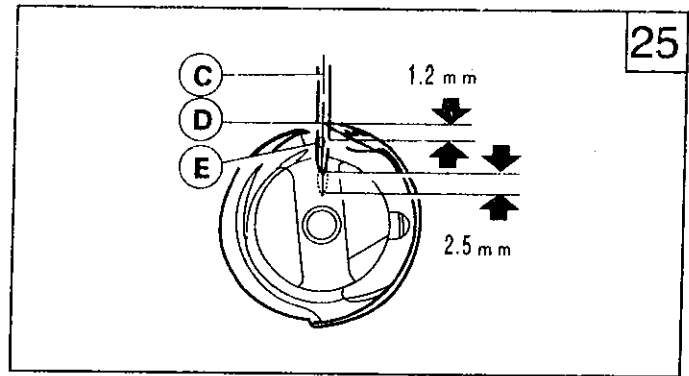

22. Removing and installing the rotating hook (Fig 27)

Lift the needle bar to its highest position, remove the throat plate, take down the needle and the bobbin case. loosen rotating hook bobbin case holder position bracket screw (C) and take down position bracket (A), then loosen set screw (D) of rotating hook to keep hook freely, turning around its axis, turn the balance wheel first to raise the feed bar to its highest position, at this time, take down the rotating hook slowly while turning it to keep away from the feed dog support. Installing the rotating hook can be done in reverse sequence.

The projecting flange of the position bracket (A) should be engaged in the notch (B) of the bobbin case holder, and maintain a clearance of 0.5~0.7mm between projecting flange top and the bottom of notch while installing.

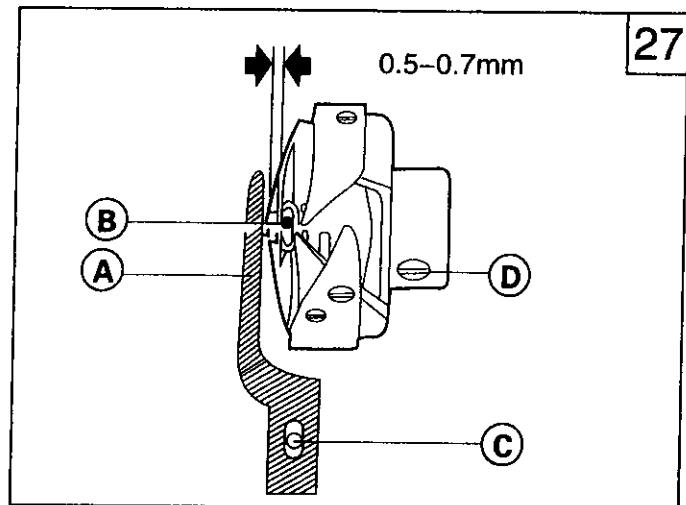

23. Installing feed dog (Fig 28, 29)

When feed amount is at the max. The front end of feed dog (A) is near the front of throat plate slot, the gauge between the two is 1.5mm. This is the standard position of feed dog.

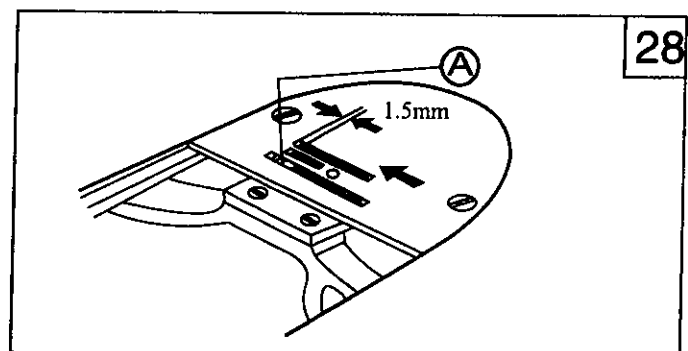

To adjust the position of feed dog, move feed dog to the front end of throat plate, Loosen Screw A (See Fig 29b), move feed dog support B in the direction shown by arrow (Fig.29a) to adjust. After adjustment tighten Screw(A).

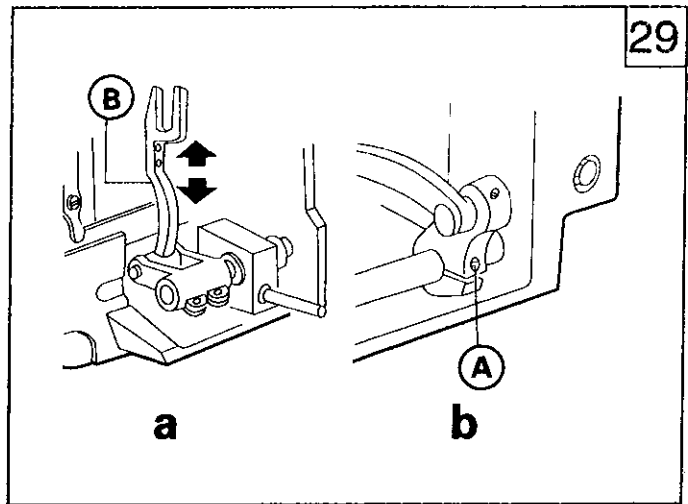

24. Feed dog horizontal Adjustment (Fig 30)

Feed dog is 0.8~1.2mm above the surface of throat plate horizontally.

When sewing condition requires tilting, adjust like this:

loosen Screw(A)

Press against the slot of eccentric shaft with a screwdriver to turn eccentric shaft left and right.

Tighten Screw(A).

The front of feed dog is higher, which can prevent perckering and no skipping.

The front of it is lower, which can prevent maferial sliding and no breakage of bobbin thread.

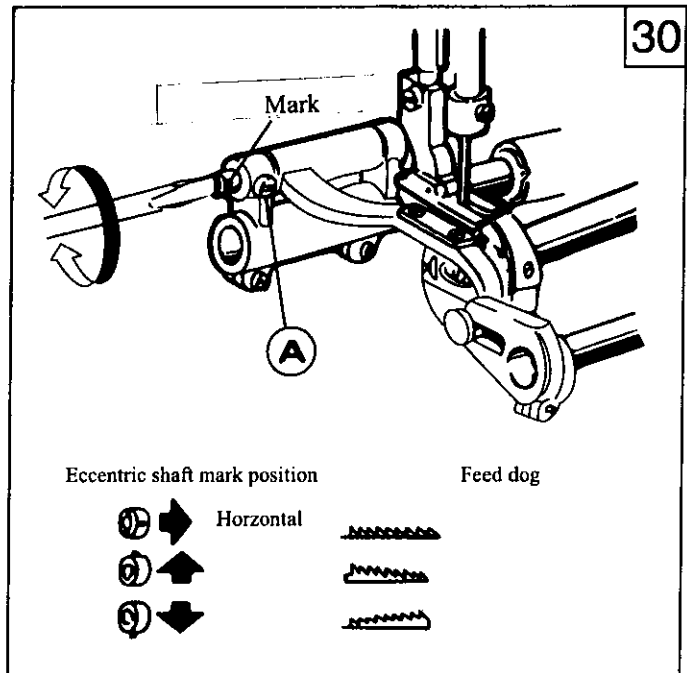

25. Stitich length error adjustment (Fig 31)

Loosen Screw (A), and turn stitch length adjusting cam (B).

Turn clockwise: forward sewing, stitch length enlarged; reverse sewing, stitch length shorten.

Turn counter-clockwise: forward sewing, stitch length shorten; reverse sewing, stitch length enlarged.

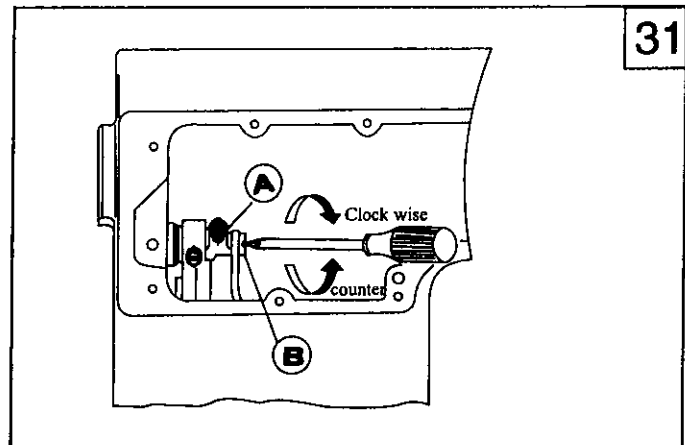

26. Feed timing adjusting (Fig 32, 33, 34)

1. Standard position

Turn balance wheel to lower Feed dog (A) till it is horizontal with the surface (B) of throat plate, at the moment, the tip of needle (C) should be horizontal with the surfaces of throat plate and feed dog.

Adjustment can be done by adjusting the position of feed cam and feed dog lift cam.

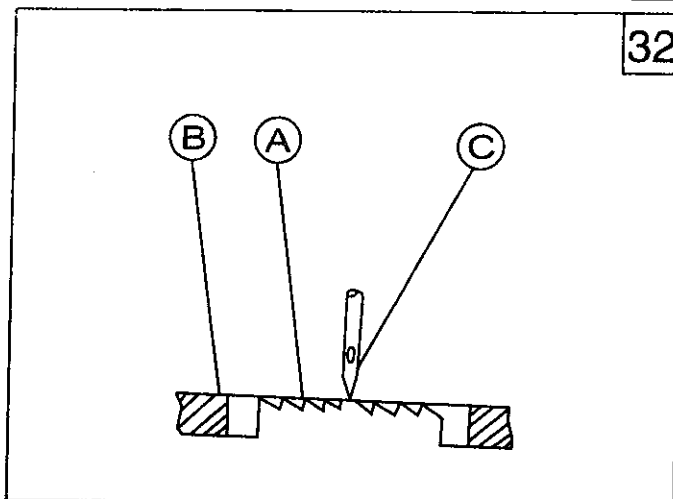

2. Installing feed dog lift cam (See Fig 33)

Open the back side cover, turn balance wheel by left hand counter-clockwise, take Screw A as for the standard, the center of Screw B is slightly a little lower than the center of Screw A.

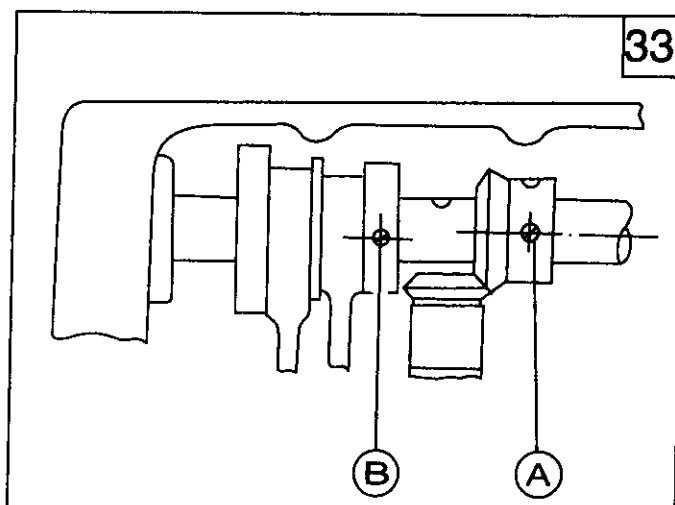

3. Installing feed cam (See Fig 34)

Continuously turn balance wheel, take Screw (B) as for standard, the center of Screw (C) is slightly a little higher than the center of Screw (B).

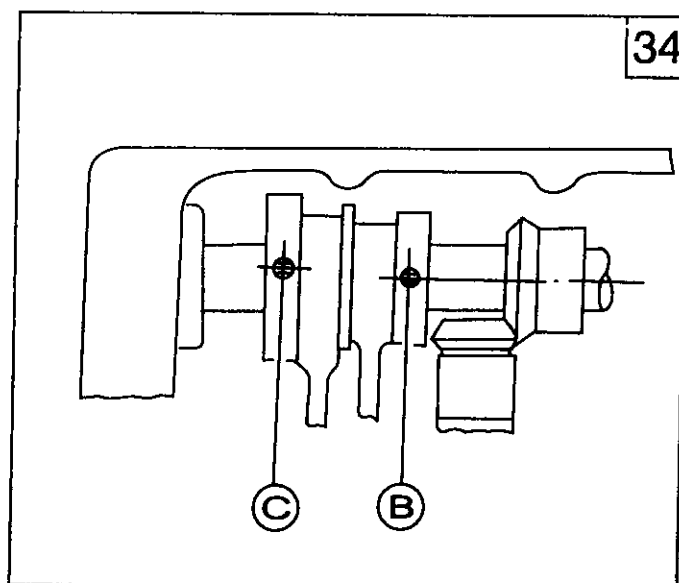

27. Adjusting the tension releasing mechanism (Fig 35)

The tension discs should be pushed apart to open when the presser foot is lifted. But the open timing of the tension discs can be adjusted as follows: Remove face plate and the rubber plug at rear side of arm and loosen screw (A) of the knee lifting lever (left), then the tension releasing cam can be moved leftward or rightward when the cam is moved rightward, it is later to open, otherwise it is earlier to open.

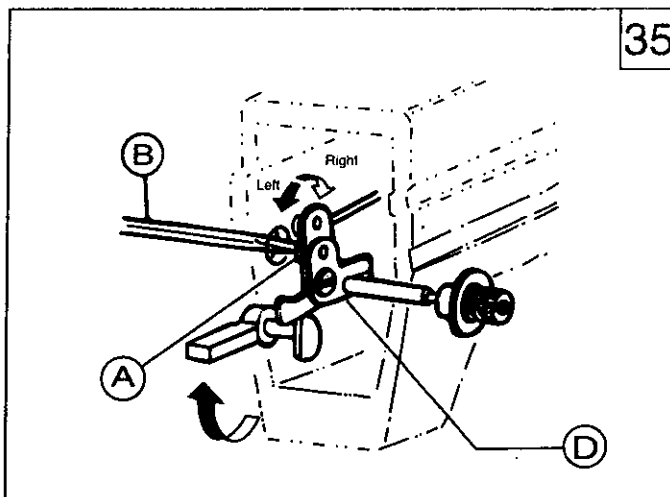

28. Upper feed adjustment (Fig 36)

During the sewing, the center gauge (L) between the walking foot sliding block and its shaft can be adjusted according to the differences of the friction coefficients of the friction coefficients of materials and the sewing process.

Method: Increase L — the upper feed amount enlarged

reduce L — the upper feed amount shorten

For special sewing requirements, for example, the upper layer of material needs more amount than the lower layer does, in this case, adjustment can be done in the range of above theory for operation.

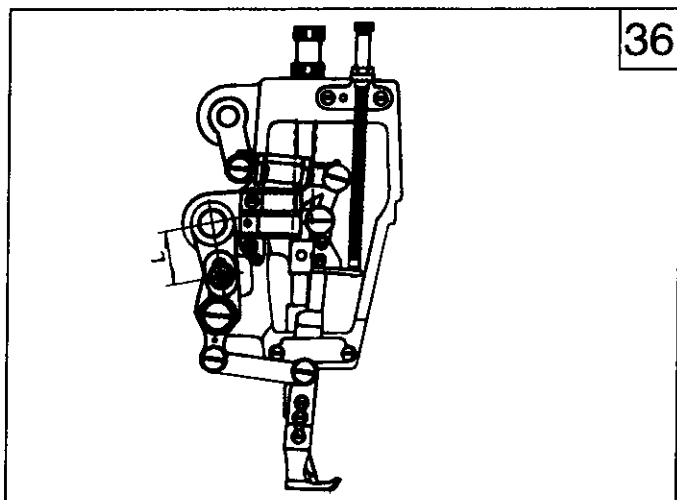

29. Adjusting presser foot alternate lift mechanism (Fig 37)

During the sewing, the alternate lift amount can be adjusted according to the nature of material. In general sewing, the amount of walking foot is 5.5mm, and the presser foot lift amount is 3.5mm.

Method: loosen the screw A. turn presser foot front crank upward to increase the amount of walking foot; turn it downward to reduce the presser foot amount, the range of adjusting amount is not too large. After adjustment, tighten the screw.

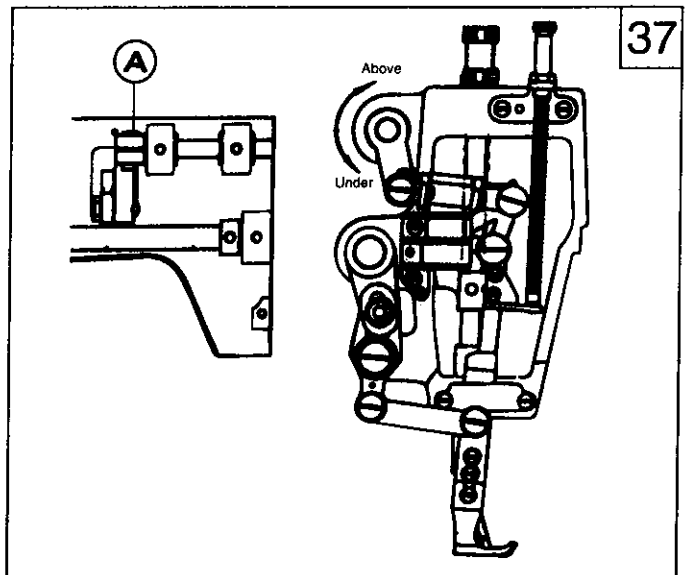

30. Adjusting the lift amount of presser foot together with walking foot (Fig 38)

The lift amount of walking presser foot together with presser foot can also be adjusted slightly. When adjusting, loosen screw (A) adjust its center distance B between the screw (A) and the presser foot lift shaft. The lift amount is increased as to shorten the center distance B, and the lift amount is decreased as to widen the center distance B. After adjustment, tighten the nut again.

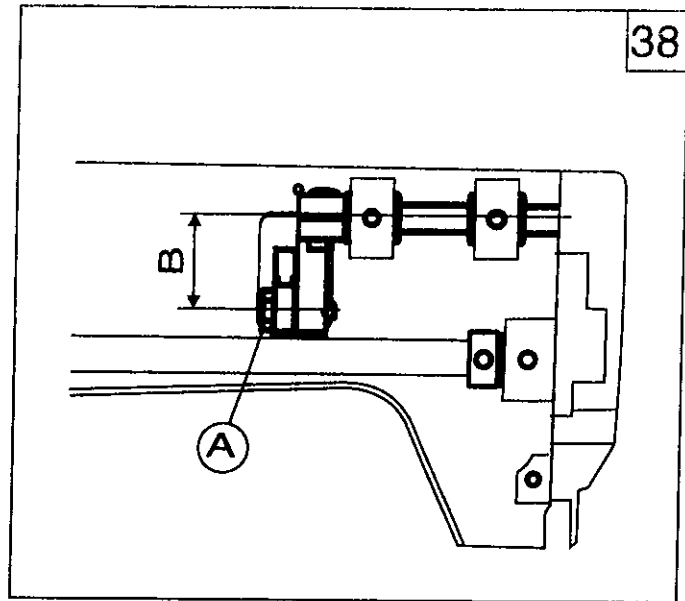

31. Adjusting the clearance between presser foot and walking foot (Fig 39)

In sewing operation, for preventing the walking foot from striking on presser foot a proper clearance C of approx. 1.5mm should be maintained between them. When the clearance is too small or too big, necessary to adjust, loosen rear crank screw and turn the rock shaft, then the walking foot moves near the needle bar. When adjust, be sure to note the fixed number of the clearance C.

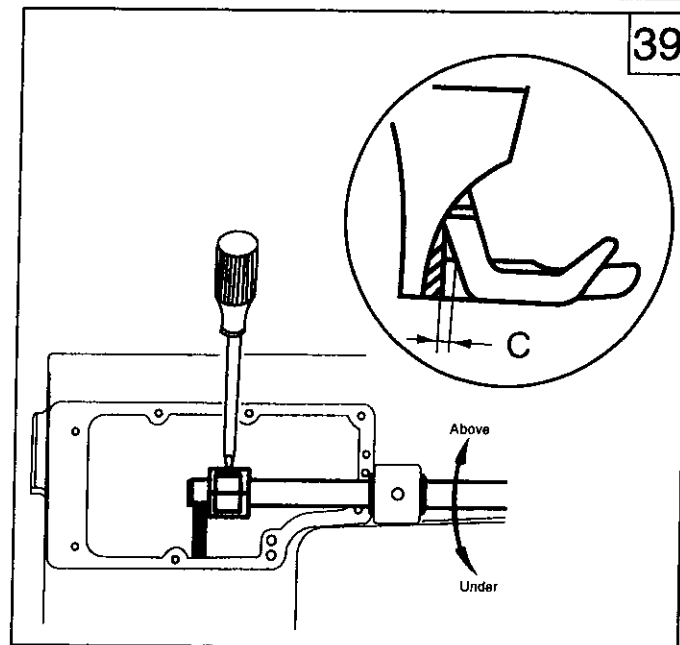

32. Periodical cleaning (Fig 40, 41, 42)

Clean the feed dog, the rotating hook, the bobbin case, the oil pump, filter screen and the like periodically according to customer's usage.

1. Cleaning the feed dog

Remove the throat plate, clean off all the dust and lint on the slit of the feed dog (A), then install the throat plate.

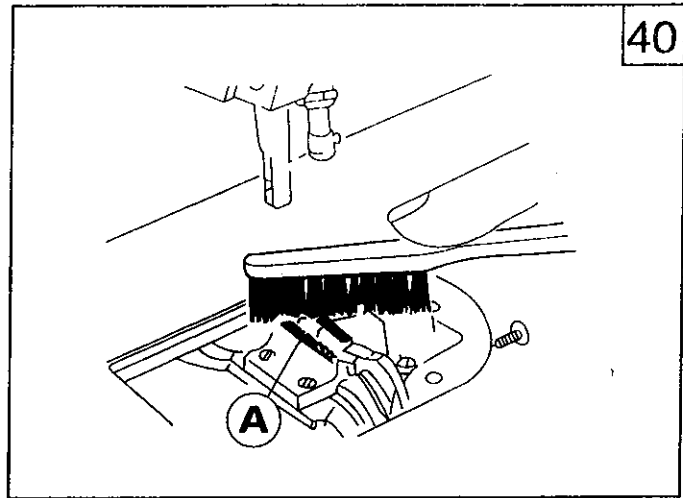

2. Cleaning the rotating hook

Clean off all the dust around the rotating hook (A), and clean the bobbin case with soft cloth.

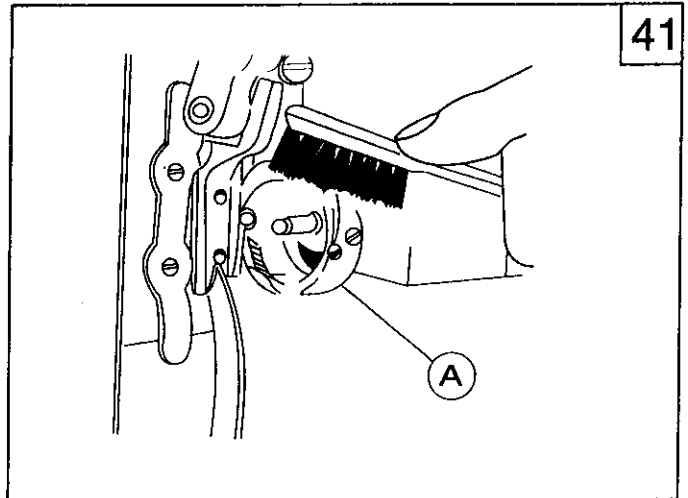

3. Cleaning the oil filter

Take off the oil filter, clean off the dust of filter screen (A) with gasoline.

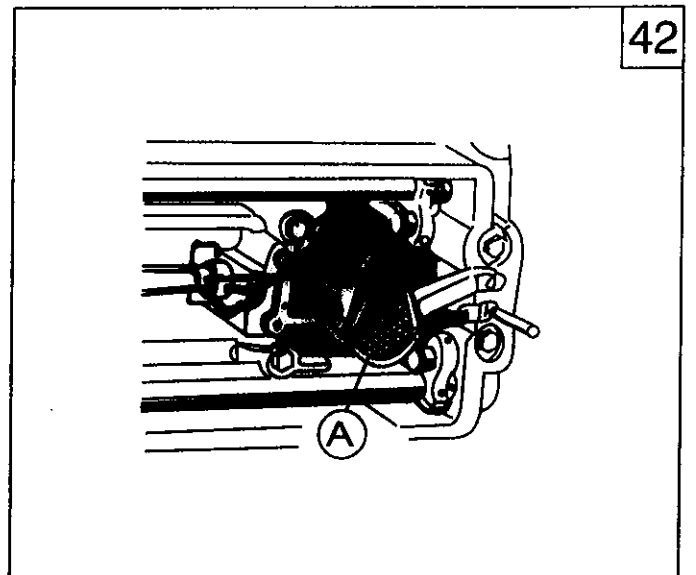

Consolidated Sewing Machine Corp.

website: www.consew.com

MAIN office

131 W. 25th Street
New York, NY 10001
Tel: 212-741-7788
Fax: 212-741-7787
e-mail: consew@att.net

Miami, FL

4013 N.W. 79th St.
Miami, FL 33166
Tel: 305-471-0200
Fax: 305-471-0243
e-mail: miamisales@consew.com

Los Angeles, CA

2320 South Hill Street
Los Angeles, CA 90017
Tel: 213-745-8844
Fax: 213-745-8855
e-mail: lasales@consew.com

Tokyo, Japan

28-16, Nishi-Shinkoiwa 5-Chome
Katsushika-Ku 124-0025
Tokyo, Japan
Tel: 81-3-5698-1639
Fax: 81-3-5698-1626
e-mail: info@consew.jp