

HIGH-SPEED INDUSTRIAL SEWING MACHINE

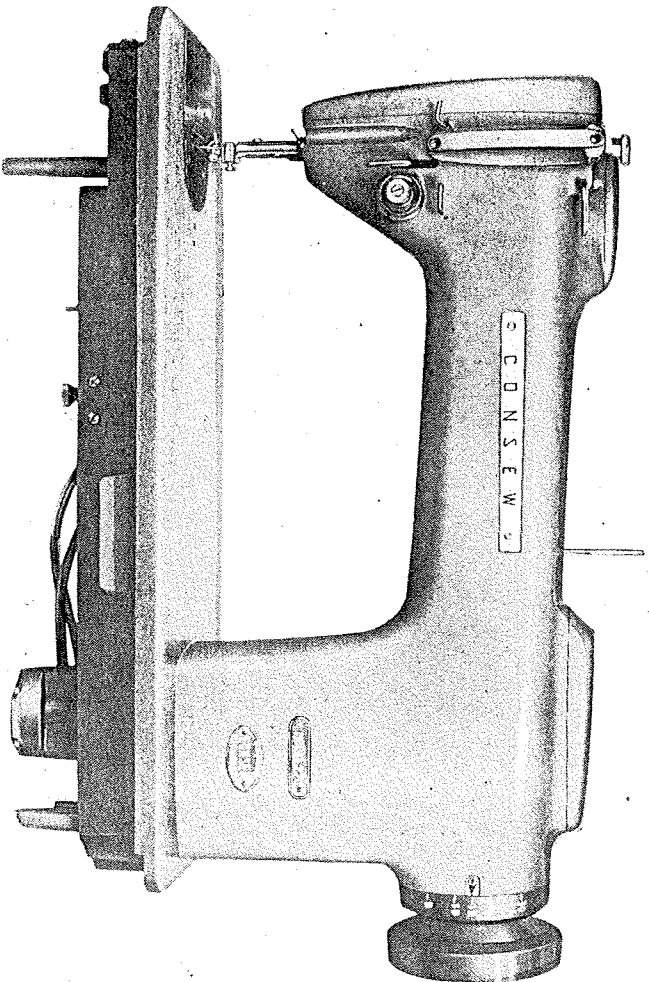

Single-Needle Lock Stitch with
fully automatic Lubrication

USER'S HAND BOOK

CONSEW MODEL 220

CONSEW^{Since 1929}
CONSOLIDATED SEWING MACHINE CORP
131 West 25th St.
New York, N.Y. 10001

ADJUSTMENT OF TENSION RELEASE

The machine is normally adjusted at the factory so that the tension of the upper thread will be released when the presser foot is raised in excess of 17/64". If it is desired to effect thread tension release with a lesser lift such as when sewing very thin materials, this adjustment can be made by the user.

To change the timing of the thread tension release, proceed as follows :

1. Remove face plate from machine making sure that its gasket will not be damaged under any circumstances.
2. Do not wipe blue-colored sealing compound from the gasket nor from any of the contact surfaces of the face plate and the arm.
3. Loosen screw A (Fig. 13) to adjust regulating arm B. Set the height of arm B so that there will be upper thread tension when the presser foot is lifted for tacking. The upper thread tension must be completely released only when the presser foot is in fully raised position.
4. Tighten screw A securely and replace face plate making certain that all its screws are tightened uniformly.

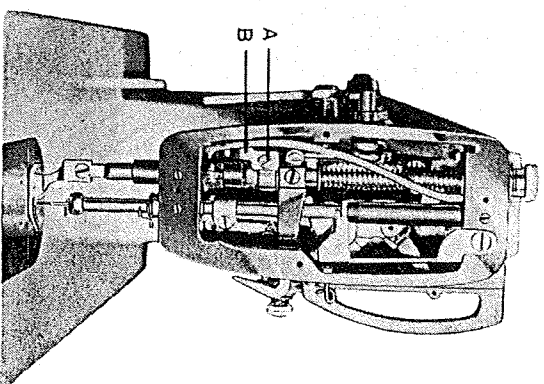

Fig. 13

Adjustment of the knee lifter

The knee lifter mechanism is assembled to the oil pan of the machine except that for shipping purposes lever (J) and knee pad (K) are disassembled. After the oil pan has been positioned in the table top and the head set in place and locked to the oil pan, insert lever and knee pad as shown in Fig. 12. Tighten their respective set screws when in most comfortable position for the operator. While lever (J) is shown inserted from the left, it can also be inserted from the right whenever more knee space is desired. Set stops of knee lifter mechanism so that there is only little play before it starts to lift the presser foot and to allow raising of the presser foot all the way but not beyond the maximum. This will avoid any possible strain on the lifter mechanism and the related parts of the head itself.

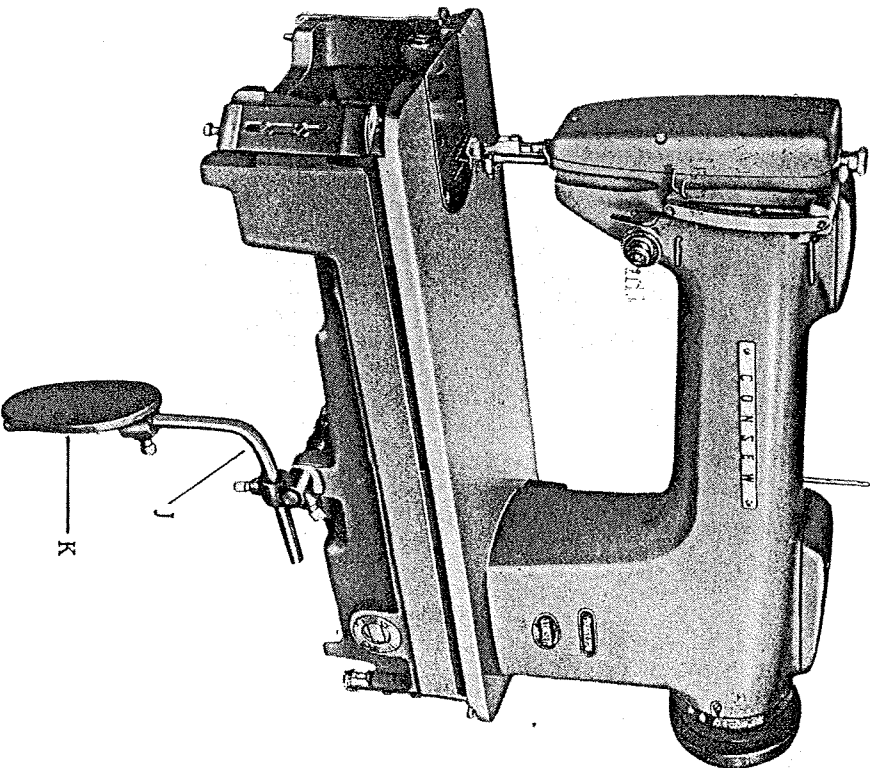

Fig. 12

The Bobbin Winder

The bobbin winder is mounted on the table top with its pulley in front of the driving belt so that the pulley will separate from the belt after the bobbin has been wound with sufficient thread (Fig. 11).

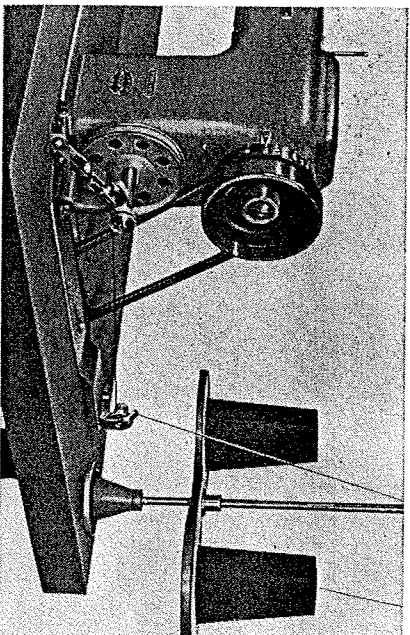

Fig. 11

1. Push bobbin on bobbin winder spindle as far as it will go.
2. Pass thread from thread stand downward through eye in tension bracket, then between and around the back of the tension discs. Bring thread forward toward bobbin and wind from below in clockwise direction several times around bobbin.
3. Push bobbin winder lever downward until wheel contacts the drive belt and start machine.
4. After bobbin is filled with thread, release will cause wheel to disengage from belt and winding will stop. Cut thread and remove bobbin from bobbin winder spindle.
5. Adjustment screw can be turned in or out to increase or decrease the amount of thread wound on the bobbin.

When fine thread is wound on bobbins, use light tension. It is regulated by turning the knurled nut on the tension bracket at the rear of the bobbin winder. Bobbin can be wound while the machine is sewing.

How to Adjust the Length of Stitch

When a change in the length of the stitch is desired, machine must first be brought to a dead stop to avoid serious damage to its internal mechanism. Now press stitch regulator button B (Fig. 10) and turn balance wheel slowly toward you until this button drops into a notch within the arm of the machine. Keeping button depressed, turn balance wheel forward of backward to increase or decrease the length of stitch. Finger F will point to the approximate number of stitches per inch. Release button after the required stitch length has been selected.

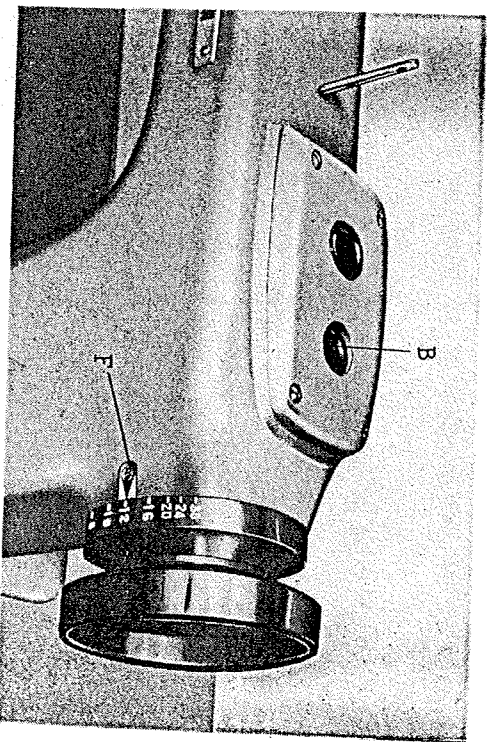

Fig. 10

A. Tension of the Upper (Needle) thread

Before adjusting the tension of the upper thread, be certain that the presser foot is let down and not in lifted position. Turn serrated nut "N" on tension device to the right to increase tension and to the left, if you desire to decrease it.

B. Tension of the lower (bobbin) thread

The tension of the lower thread is regulated by the screw on the bobbin case tension spring (see Fig. 8). Use the small driver to tighten the screw slightly to increase the tension, or loosen it to slacken the tension.

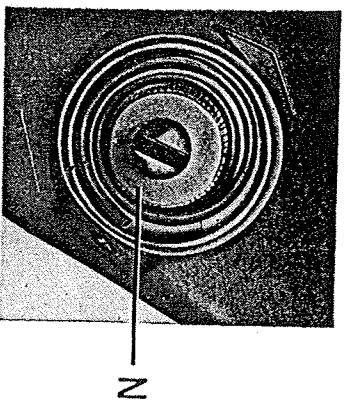

Fig. 7

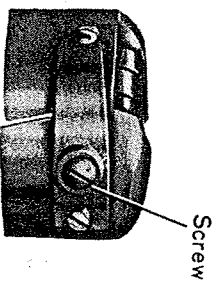

Fig. 8

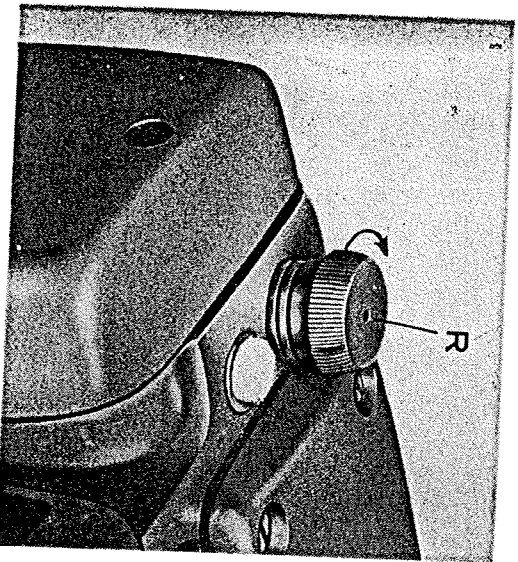

Fig. 9

To Regulate the Pressure of the Presser Foot

The pressure of the presser foot on the material is regulated by the Regulator Screw (R) (Fig. 9) on top of the machine. Turn this regulator to the left to decrease it. Do not employ more foot pressure than is required to feed the material properly.

To Regulate the Tensions

For ordinary stitching, the tension on the upper and lower threads should be equal so as to lock both threads in the center of the fabric,

Thus:



If the tension on either thread is stronger than on the other, imperfect stitching will be the result. If the tension on the upper thread is greater than that on the lower thread, it will lie straight along the upper surface of the fabric,

Thus:



If the tension on the lower thread is greater than that on the upper thread, the lower thread will lie straight along the underside of the fabric,

Thus:



Inserting a New Needle

Turn handwheel of machine toward you until needle bar reaches its highest point. Loosen set screw in needle clamp at bottom end of needle bar and push needle up into bar as far as it will go. Long groove in needle must face toward the left and the eye must be in line with the arm of the machine. Tighten needle set screw securely.

To Commence Sewing

Turn the balance wheel toward you with the right hand until the needle moves down and up again to its highest point, thus catching the lower (bobbin) thread. Now pull the end of the upper thread you are holding and the bobbin thread will be brought up with it through the needle hole in the needle plate, as shown in (Fig. 6). Place both ends of thread back under the presser foot. Place the fabric to be sewn beneath the presser foot, lower the foot upon it and then start the machine.

To Remove the Work

Raise the needle bar to its highest point, lift the presser foot and draw the fabric back and to the left. Cut the ends of the threads a few inches long from the needle.

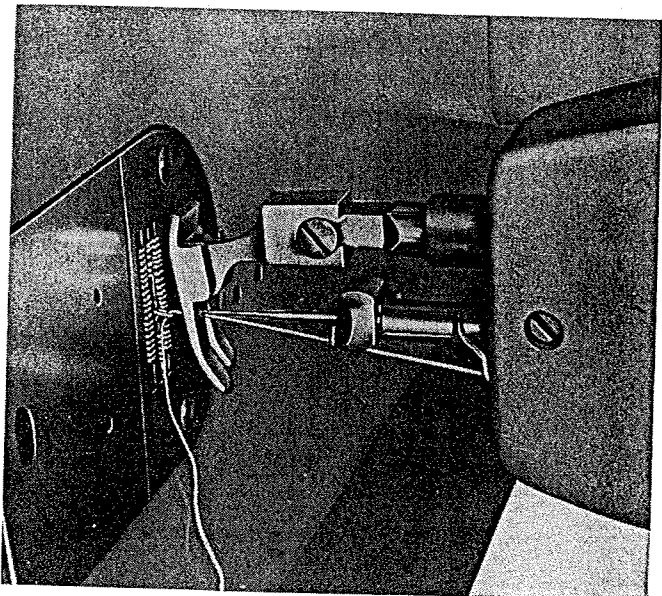

Fig. 6

Threading and Inserting the Bobbin Case

Hold the bobbin between the thumb and forefinger of your right hand and pull out a length of two or three inches of thread. Holding the bobbin case in your left hand, turn the open side up and place the threaded bobbin into it.

With the right hand guide the thread into the slot in the edge of the bobbin case.

Then pull the thread to the left, under the tension spring and into the delivery eye.

In order to keep the bobbin from dropping out of the case when it is turned with the open side down, always keep the hinged latch at the front of the bobbin case open.

Take the threaded bobbin case by the latch and place it on the center stud A (Fig. 5) of the bobbin case holder. Release latch and press bobbin case onto center stud until the latch catches the undercut thereon with a click that can be heard. Permit two to three inches of bobbin thread to hang down freely. Be sure to push slide plate to the right before starting to sew.

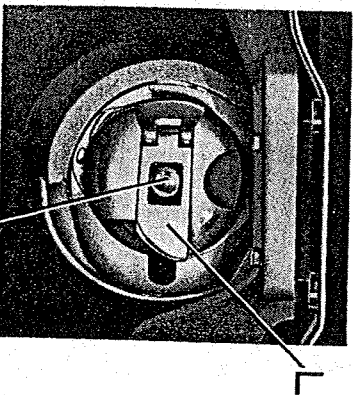

Fig. 5

Threading the machine

Turn handwheel toward you until needle (10) reaches its highest point and take-up lever (7) is near the end of its upward travel, as shown on Fig. 4. Lead thread from hole of spool pin (1) through three holes in thread guide (2), then downward through guard (3) and between and around tension discs (4) from right to left. Upward into thread take-up spring (5) and down under slack thread regulator (6), up and through guard (3) into eye of take-up lever (7) from right to left, down through thread guides (8 and 9) into thread guide (10) and from left to right through the eye of the needle. Pull two to three inches of thread through the eye of the needle.

Removal of bobbin case

Turn handwheel toward you until needle reaches its highest point. Open slide plate by pulling it to the left. Pass left hand under table into opening on oil pan. With left thumb and index finger open the hinged latch (L) (Fig. 5) at the front of the bobbin case. Grasp latch and pull bobbin case and bobbin from rotary hook. While the latch is held open, the bobbin will be retained in the bobbin case. Release of the latch and turning of the open side of the bobbin case downward will cause the bobbin to drop out.

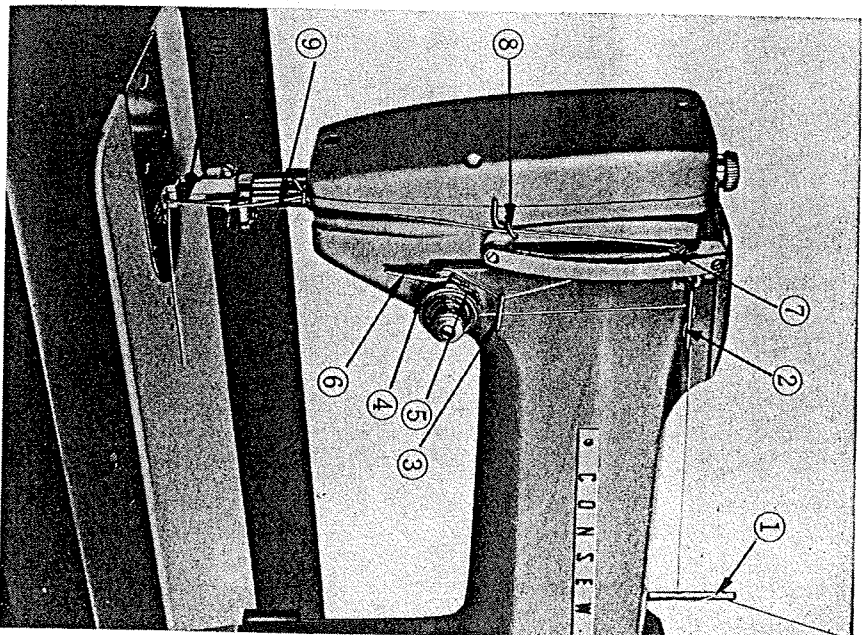

Fig. 4

The oil supply for the rotating hook can be controlled through adjustment of the needle valve "V" at the underside of the machine bed (Fig. 3). While this valve is adjusted at the factory to feed the correct amount of lubricant, operating conditions may require either an increase or a decrease in the oil flow to the hook. To determine the amount of oil supplied to the hook, hold a piece of tissue or similar paper under the hook and operate machine. After a very brief period of operation a slight trace of oil should become visible on the paper. If not, check flow and adjustment of needle valve. Also, remove from oil screen "S" at bottom of oil pump "O" any accumulation of lint or other foreign matter, at the same time lift the magnet from the rim of the oil pump, wipe it clean and replace it.

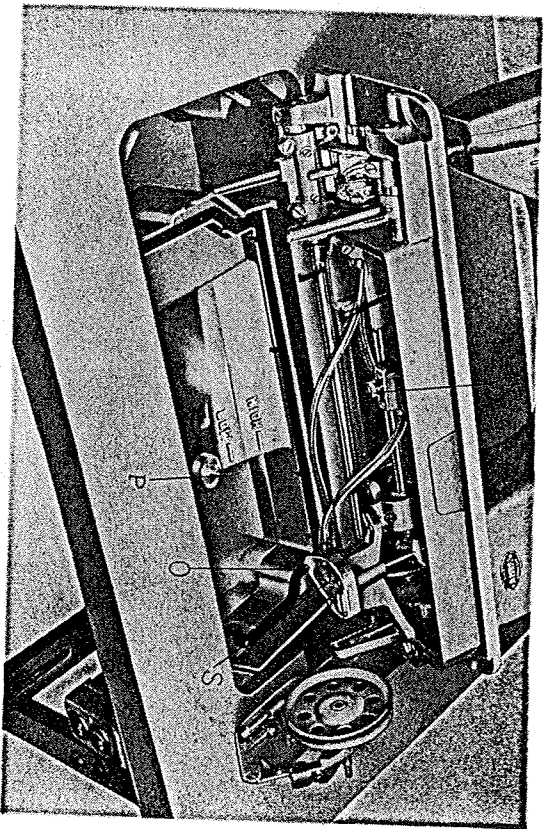

Fig. 3

The Lubrication System

Oiling of the operating parts of Model 220 machine is entirely automatic. Oil is contained in the oil pan at the bottom of the machine head and is circulated from there to all parts which require lubrication and cooling. The oil pan should be filled with good quality sewing machine oil, either ordinary or stainless type, of a grade similar to SAE10 to the level indicated by the word "High" inside the pan. The upper red line of the oil level indicator (2), (Fig. 1) shows the corresponding oil level. Check oil level daily and never allow it to fall below the lower red line of the oil level indicator or below the "low" mark inside the oil pan. Oil is filled directly into the oil pan when the head is tilted back. Total oil capacity is approximately 1½ pints (24 fl. ounces.)

To remove accumulated impurities from the lubricating oil, a magnet has been included with the machine. Remove it from the accessory box and place it along the circular flat rim at the bottom of the oil pump (see Fig. 3). At this location, the largest flow of oil passes the magnet with most efficient cleaning as a result.

NOTE: Before operating a new machine or one which has been standing idle for a period of several weeks, remove the arm cover plate right next to the pressure regulator (7). Soak with oil the four oil wicks now exposed and replace cover. After a few minutes of operation the automatic oiling system will do the lubricating.

The oil pan fits into standard size table cut-outs (19" x 7 $\frac{1}{4}$ ") and is supported at the four corners without screws or bolts. The weight of the head alone suffices for accurate seating. Note that the oil pan must settle down easily into the cut-out without use of force. If necessary rasp the edges of the cut-out and those of the corner supports.

No felt pads are required on top of these corner supports. They should be removed, if the machine is to be installed into an old table. To level the oil pan within the table cut-out, put machine head in place, having inserted the hinge hooks into the bed beforehand. With the machine head resting on the neoprene rubber oil pan gasket, turn adjustment screws (Fig. 2) until top of machine bed projects evenly above the surface of the table top. The machine hinges must not support the head except when it is tilted back.

Insert plunger "P" into its seat inside the oil pan (Fig. 3) and assemble knee lifter lever and pad to its component parts at the front of the oil pan. Adjust stops of knee lifter mechanism so that there is only a little play before it starts to lift the presser foot and that it is raised all the way without any strain on the lifter parts and without tendency to lift the entire head.

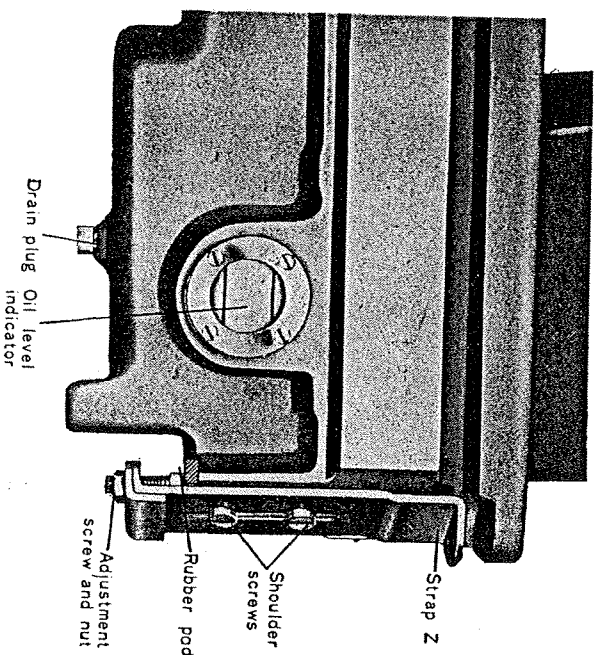

Fig. 2

CHARACTERISTICS

1. The CONSEW Model 220 machine for sewing light, medium, and heavy-weight material is all-gear driven and automatically lubricated at every bearing with separately adjustable oil feed for the rotary hook. All bearings are diamond bored sleeve types, except for needle bearings at the thread take-up.
2. Drop Feed design with a maximum stitch length 6 to the inch.
3. The belt groove in the machine handwheel has an effective diameter of $2\frac{9}{16}$ " when using $\frac{3}{8}$ " wide "V" belting. For $\frac{5}{16}$ " dia round belting the effective diameter is $2\frac{3}{8}$ ".
4. Maximum presser Foot lift is $\frac{3}{8}$ ".
5. Needle style 16 x 257 (all sizes)

IMPORTANT NOTE:

Do not operate machine for any reason whatsoever unless oil reservoir has been filled and machine has been oiled according to instructions on page 5.

Maximum operating speed is 50,00 stitches per minute

How to set up

For purposes of shipment the machine and its oil pan are separated. Unpack machine with great care to prevent loss of any assembly part and to prevent the entry of foreign matter into the head and the oil pan. Attach to oil pan corners the four Z-shaped straps using two shoulder screws each. Loosen adjustment screws at bottom of straps until there is clearance between screw heads and rubber pads at underside of oil pan. (Fig. 2)

Description:

1. Stich Regulator
2. Oil level Indicator
3. Knee Lifter Lever
4. Needle Clamp
5. Tension Regulator (upper thread)
6. Thread Take-up lever
7. Pressure Regulator
8. Oil Feed Window

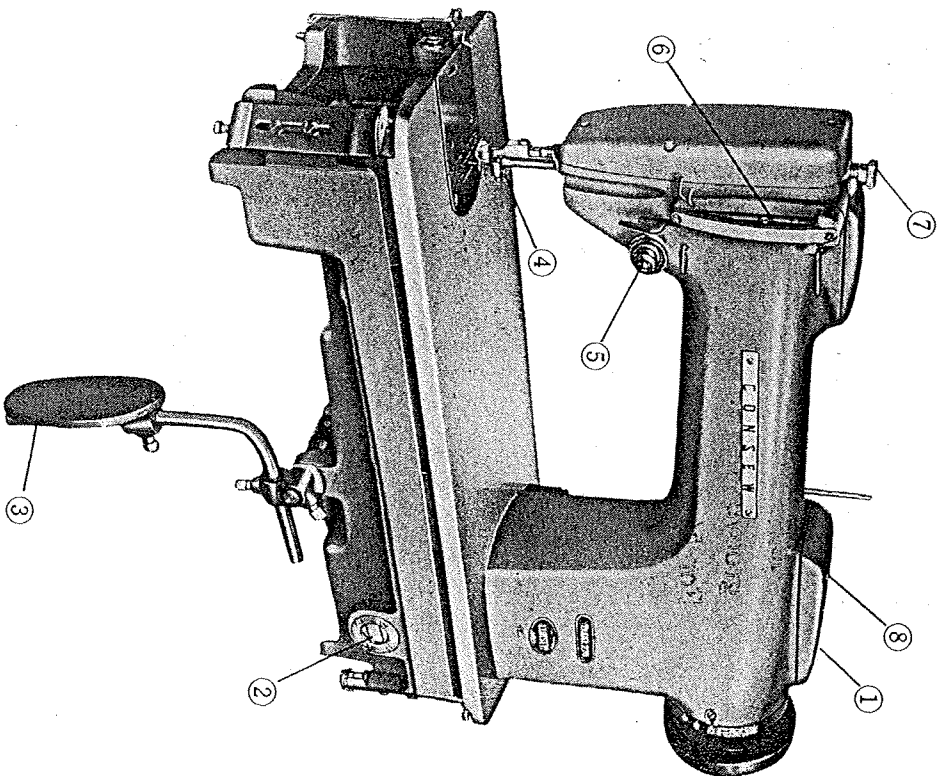

Fig. 1

NEEDLE AND THREAD CHART

Sizes of Needles	Classes of Work	Sizes of Cotton, Linen or Silk
14	Shirtings, Sheetings, Calicoes, Muslins, Silks, Dress Goods and all classes of general work	60 or 80 Cotton A and B Silk
16 & 17	All kinds of Heavy Calicoes, Light Woolen Goods, Heavy Silk, Seaming, Stitching etc.	40 to 60 Cotton C Silk
18	Tickings, Upholstery, Woolen Goods, Trousers, Boys' Clothing, Cloaks, etc.	30 to 40 Cotton D Silk
19	Heavy Woolens, Tickings, Bags, Heavy Coats, Trousers and Heavy Clothing generally	24 to 30 Cotton E Silk 60 to 80 Linen
21	Bags, Coarse Cloths & Heavy Goods	16 to 20 Cotton 40 to 60 Linen