

MODEL **DDL-227**

**HIGH SPEED SINGLE NEEDLE,  
LOCK STITCH  
INDUSTRIAL SEWING MACHINE**

---

# **INSTRUCTION BOOK**

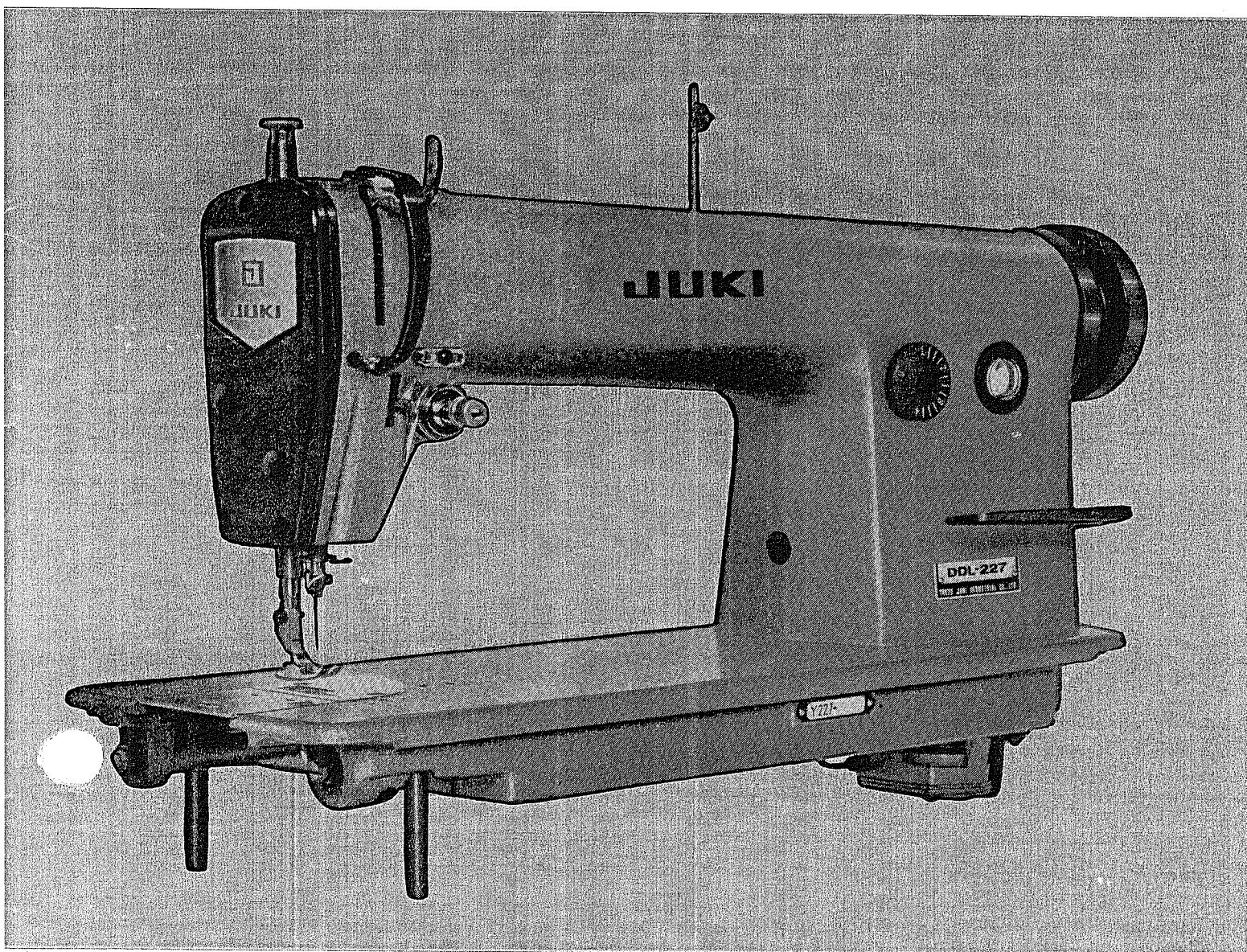

**TOKYO JUKI INDUSTRIAL CO., LTD.**

JUKI Model DDL-227 is a high speed, single needle, lockstitch industrial sewing machine equipped with a reverse feed, link type thread take-up mechanism.

This machine can do a complete sewing process with a high speed of up to 4,500 s.p.m. The thread take-up, sewing hook and the feed mechanism components are specially designed and constructed for high speed sewing of general fabric and thus even at high speed sewing, the stitching condition is excellent and the running sound is very quiet.

### **DDL-227 SPECIFICATIONS**

- Sewing speed . . . . . Up to 4,500 s.p.m.**
- Stitch length . . . . . 0—4 mm(5/32")**
- Stitch adjuster . . . . . Dial system**
- Reverse sewing . . . . . Lever system**
- Needles . . . . . DB X 1 (16X231) #11, #14, #16, #18**
- Lubricating oil . . . . . New Defrix Oil No. 1**

## DDL-227 CONTENTS

	Page
Installing the oil reservoir . . . . .	2
Motor pulley and the belt . . . . .	2
Cautions on operating the machine . . . . .	3
Lubrication . . . . .	3
1. Adjusting the oil supply to the face part . . . . .	4
2. The oil adjusting pin . . . . .	4
3. Adjusting the oil supply to the hook components . . . . .	4
Threading the machine . . . . .	5
Preparation of the bobbin thread . . . . .	6
Inserting & removing the bobbin case . . . . .	6
Winding the bobbin thread . . . . .	6
How to insert the bobbin . . . . .	6
The thread tension . . . . .	7
Adjusting the needle thread tension . . . . .	7
Thread take-up spring . . . . .	7
Adjusting the bobbin thread tension . . . . .	7
Presser foot and feed dog . . . . .	8
Adjusting the pressure of the presser foot . . . . .	8
The presser foot hand lifter . . . . .	8
Height of the feed dog . . . . .	8
The stitch length . . . . .	9
Adjusting the stitch length . . . . .	9
Reverse sewing . . . . .	9
Inserting the needle . . . . .	10
Installing and removing the sewing hook . . . . .	10
Relation between the hook and the needle . . . . .	11
Adjusting the height of the presser bar . . . . .	12
Adjusting the amount of the thread take-up . . . . .	12

(Note)

Due to improvements on the machine, some parts of the operational procedures of this INSTRUCTION BOOK might be changed without notice.

## INSTALLING THE OIL RESERVOIR

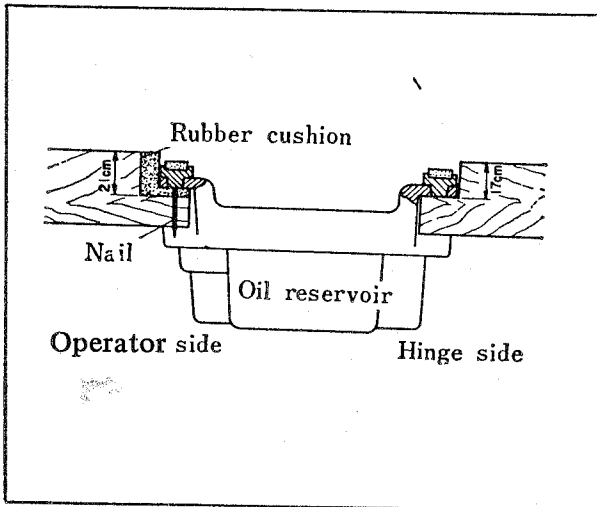

As shown in the figure, set the reservoir in such a way so that the 4 corners of the grooved part of the table will be supporting the reservoir.

1. Nail in the 2 rubber cushions in front to the protruding part of the table.
2. Place the oil reservoir on the protruding part of the table.

## MOTOR PULLEY AND THE BELT

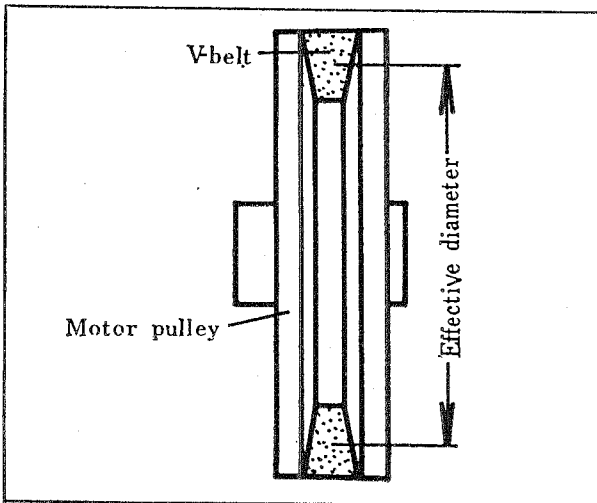

Model DDL-227 can sew at a high speed of up to 4,500 s.p.m. When connected directly to the power source, use a 3-phase 400 W (1/2 HP) clutch motor.

Use a M type V-belt. The relation between the number of rotation of the machine with the dimension of the motor pulley is shown in the table. (Effective diameter)

\* The effective diameter of the motor pulley means the diameter as measured from the center of the V-belt when the belt is wound around the machine.

Cycle	No. of rotation of machine	Part No. of motor pulley	Effective diameter of motor pulley
50	4,530 s.p.m.	MTK-PV110000	110mm (4-5/16")
	4,000 s.p.m.	MTK-PO095000	95mm (3-3/4")
60	4,540 s.p.m.	MTK-PV090000	90mm (3-35/64")
	4,040 s.p.m.	MTK-PVO80000	80mm (3-11/64")

## CAUTIONS ON OPERATING THE MACHINE

- 1 Do not run the machine, under any circumstances, before the oil reservoir is filled up with fresh oil.
2. Always rotate the machine toward the operator. Do not run the machine in the reverse direction.
- 3 This machine can run with a speed of up to 4,500 s.p.m. but for the first month, drop the speed to about 4,000 s.p.m.

## LUBRICATION

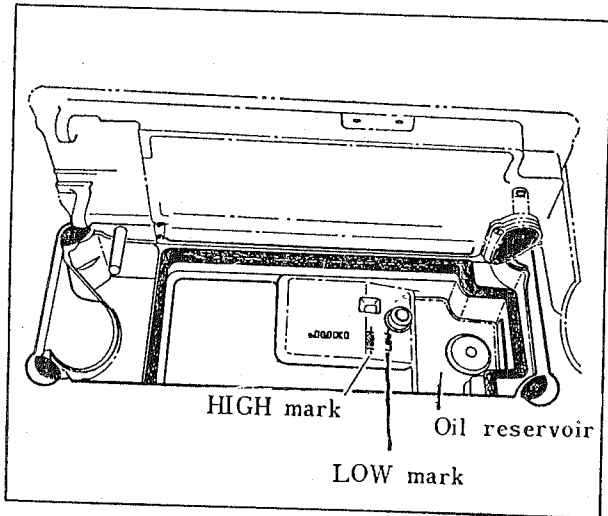

### Before operating the machine

1. Fill up the oil reservoir with JUKI New Defrix Oil No. 1 up to the mark "HIGH".
2. Watch and see that the oil level does not go below the "LOW" mark.

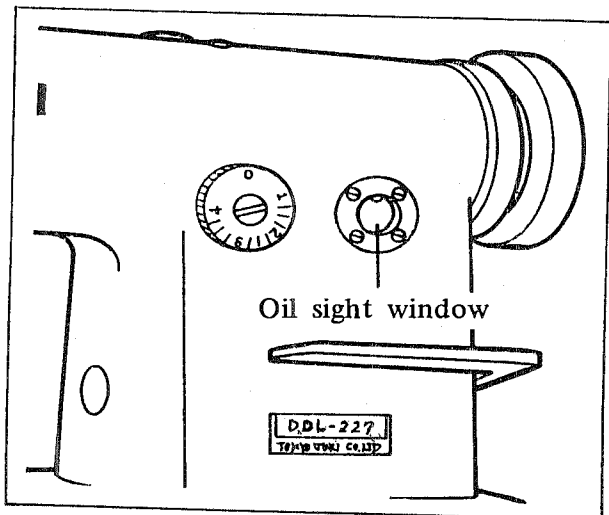

3. Under normal conditions, when the machine is run after it is filled up with oil, the oil will spurt against the oil sight window.

### (Caution)

- 1) When the oil gets dirty, change it with new, fresh oil. If the oil plug of the reservoir is removed, oil will come out.
- 2) When the machine is to be run for the first time or when it was idle for a great length of time, run the machine at 3,000–3,500 s.p.m. for about 10 minutes and allow the machine to get well-oiled.

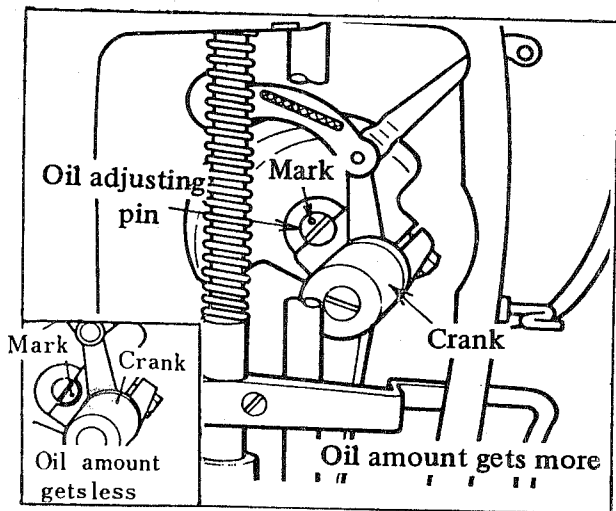

### 1. Adjusting the oil supply to the face part

When adjusting the oil supply to the thread take-up and needle bar crank components, remove the face plate and the oil preventing plate and adjust by turning the oil adjusting pin at the tip of the main shaft.

1. When the red mark of the adjusting pin comes near the crank, the oil amount gets less.
2. When the red mark comes to the opposite side of the crank, the oil amount gets more.

#### (Caution)

The oil amount does not change immediately after the adjustment, so when adjusting, have this in mind.

### 2. The oil adjusting pin

1. The oil adjusting pin has a carved groove as shown in the figure. When this groove and the oil hole of the main shaft come together, the oil amount gets more.
2. When the groove is at the opposite side of the oil hole, the oil amount gets less.
3. The red mark on the oil adjuster shows the side without the carved groove.

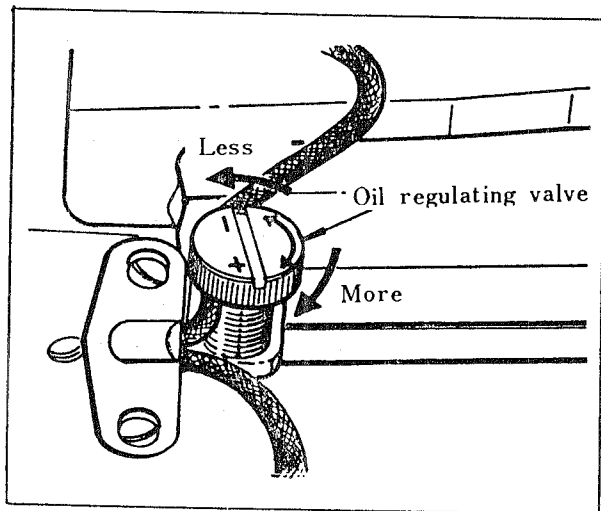
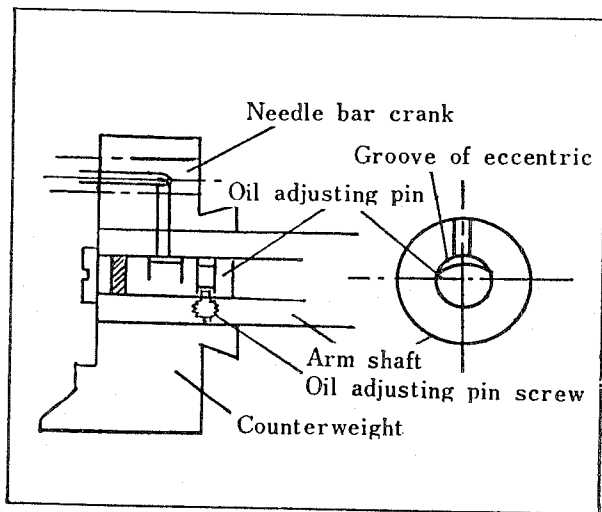

### 3. Adjusting the oil supply to the hook components

The supply of oil to the hook components can be adjusted by the oil regulating valve on the hook shaft.

1. If this valve is turned toward  $\oplus$  side(right), the oil amount gets more.
2. If this valve is turned to  $\ominus$  side(left), the amount gets less.

## THREADING THE MACHINE

- Rotate the hand wheel to right and place the thread take-up to the highest position.
1. Pass the needle thread in the order shown by the figure.
  2. Pass the thread to the needle eye from left to right.
  3. Pull out about 10 cm(4") of the thread from the needle eye.

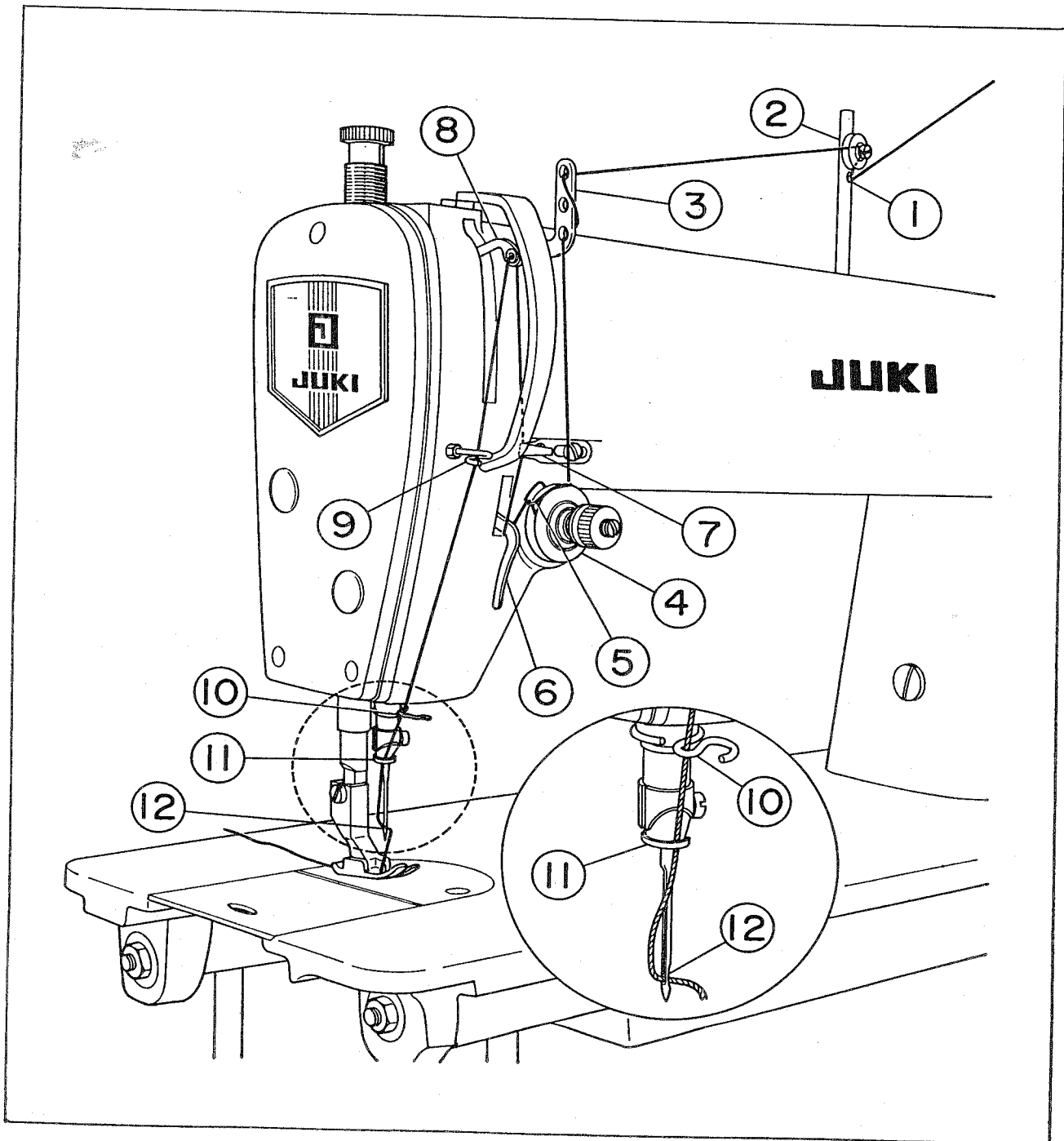

## PREPARATION OF THE BOBBIN THREAD

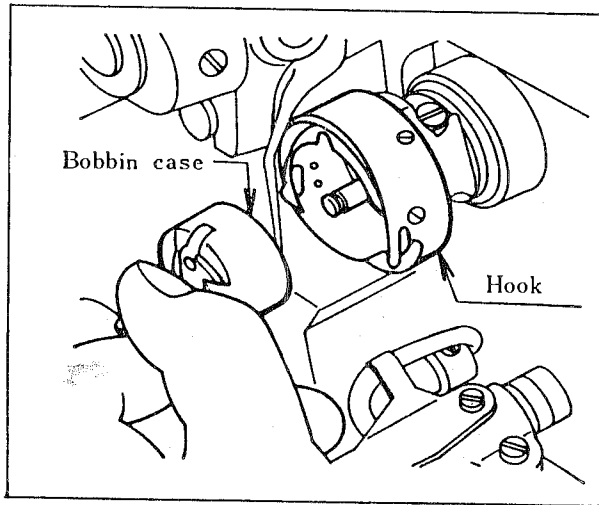

### Inserting & removing the bobbin case

1. Rotate the hand wheel with your hand and bring the needle to its highest position.
2. Tilt the machine and support it by the head support on the table.
3. Lift up the knob of the bobbin case and take it out.
- \* If you hold the knob in open condition, bobbin will not fall off.
4. To insert the bobbin case, insert it deep into the shaft of the hook so that the nose of the bobbin case fully enters the groove of the hook and then close the knob.

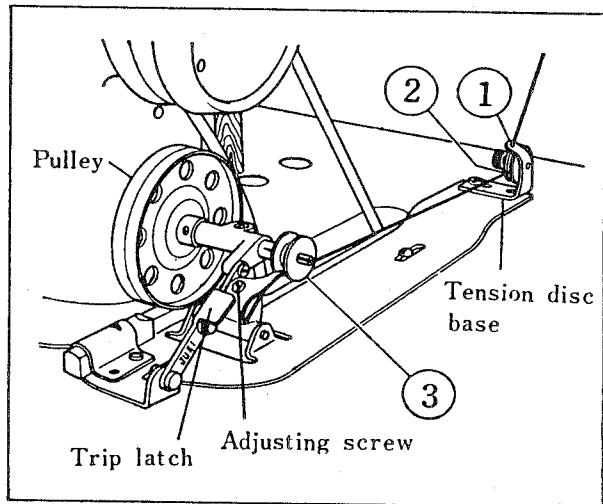

### Winding the bobbin thread

1. Set the bobbin winder to the table with screws.
2. Pass the thread in the order shown in the figure and wind it around the bobbin several times.
3. Knock down the trip latch and contact the pulley to the belt.
4. Adjust the winding amount by the winding adjusting screw so that about 80% is wound.
5. When the thread is wound unevenly, move the thread tension disc base to left and correct to even winding condition.
6. When the winding is completed, the trip latch will be released and the pulley will stop automatically.

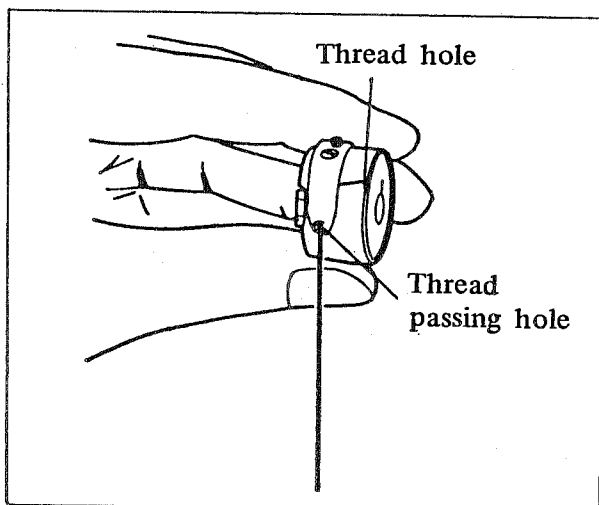

### How to insert the bobbin

1. Hold the bobbin and insert it to the bobbin case so that the thread will be in right-twist condition.
2. Pass the thread to the thread passing hole of the bobbin case.
3. Then pull the thread and it will pass under the thread tension spring and can be pulled out through the thread hole.



# THE THREAD TENSION

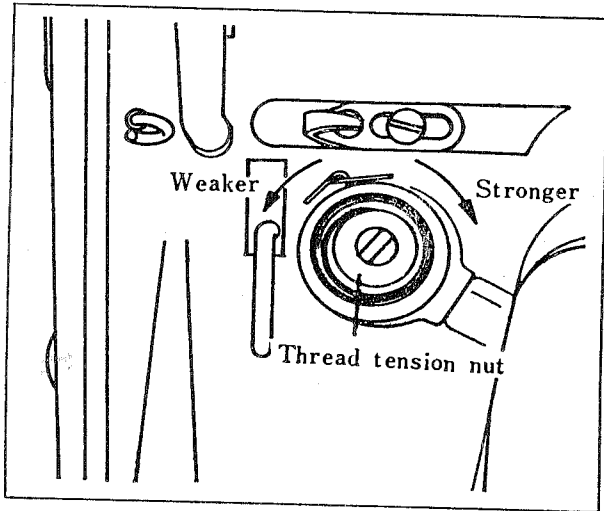

## Adjusting the needle thread tension

Ideal stitches are formed when the needle thread and the bobbin thread are perfectly interlocked at the center of the cloth. The tension of the needle thread is adjusted by the thread tension nut.

1. Turn it to right to make the tension stronger and to the left to make it weaker.

## Thread take-up spring

\* To change the moving range of the thread tension spring:

1. Loosen the screw of the thread tension bracket.

2. Rotate the thread tension bar.

\* To change the strength of the thread take-up spring.

1. Loosen the set screw, remove the thread tension bar.

2. Loosen the thread tension bar set screw and adjust.

3. When the thread tension bar is turned to right, the spring will get stronger and if turned to left, it will get weaker.

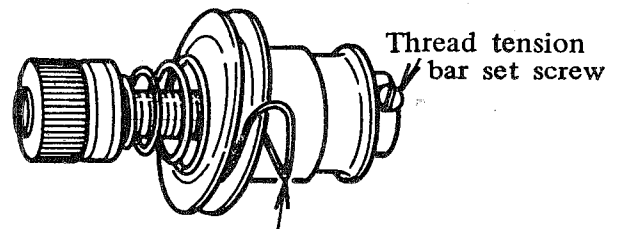
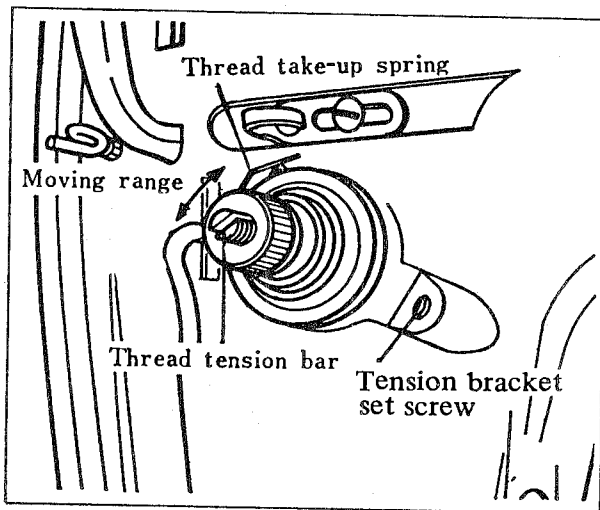

Thread take-up spring

## Adjusting the bobbin thread tension

Rotate the thread tension screw of the bobbin case to adjust the bobbin thread tension.

1. Rotate it to right to make the bobbin thread tension stronger and to left to make it weaker.

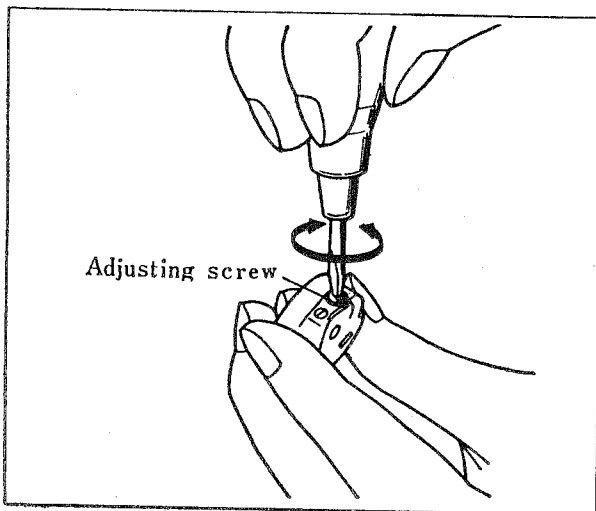

## PRESSER FOOT AND FEED DOG

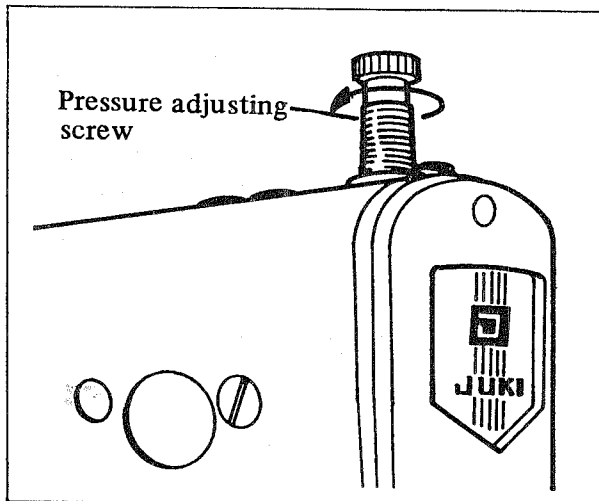

### Adjusting the pressure of the presser foot

1. Turn the pressure adjusting screw to right to make the pressure stronger and to left to make it weaker.

Normal pressure for general fabric is about 5 kg (11 lbs).

If a pressure of more than 6 kg (13.2 lbs) is required, use the exchanging spring in the accessory box.

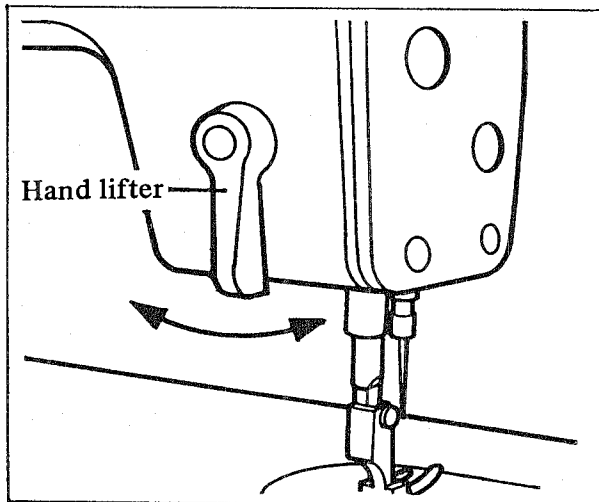

### The presser foot hand lifter

To stop the presser foot at the lifted position:

1. Rotate the hand lifter in the rear of the face part either to right or left.
2. The presser foot will go up about 5 mm (13/64") and stops.
3. To lower the presser foot, activate the knee lifter once and the presser foot will come down to the original position.
4. With the knee lifter, the presser foot will go up about 10 mm (25/64")

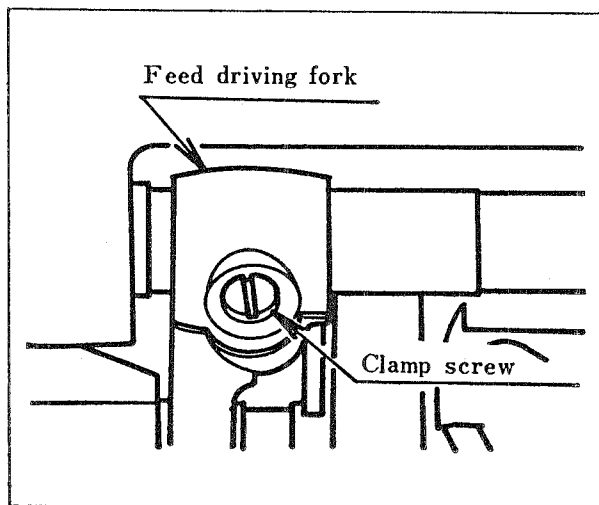

### Height of the feed dog

The height of the feed dog from the surface of the throat plate is set from 0.7–0.8 mm. In sewing light weight materials, if this height is too high, shrink-stitching may result.

To adjust the height of the feed dog:

1. Loosen the clamping screw of the feed driving fork of the compound feed.
2. Move the feed dog base up and down and adjust.
3. After adjusting, tightly tighten the clamping screw.

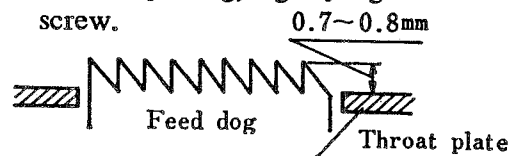

## THE STITCH LENGTH

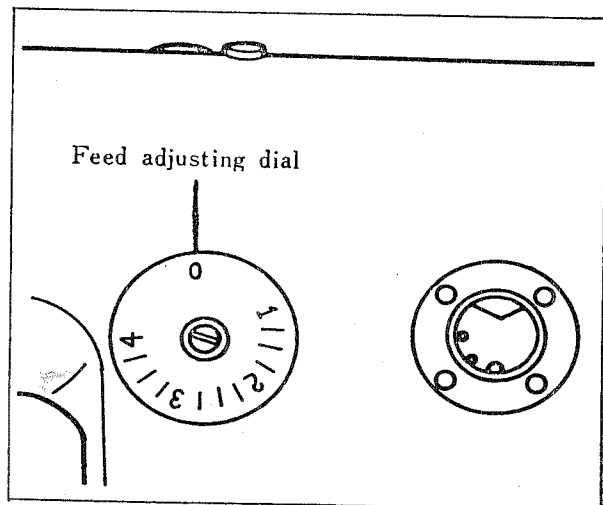

### Adjusting the stitch length

The stitch length can be adjusted by turning the feed adjusting dial above the feed lever.

The figures on the graduator are shown in mm.

1. Rotate the feed adjusting dial either to right or left.
  2. And match the desired figure with the pin which is coming out from the arm.
- \* The maximum stitch length is 4 mm(5/32")

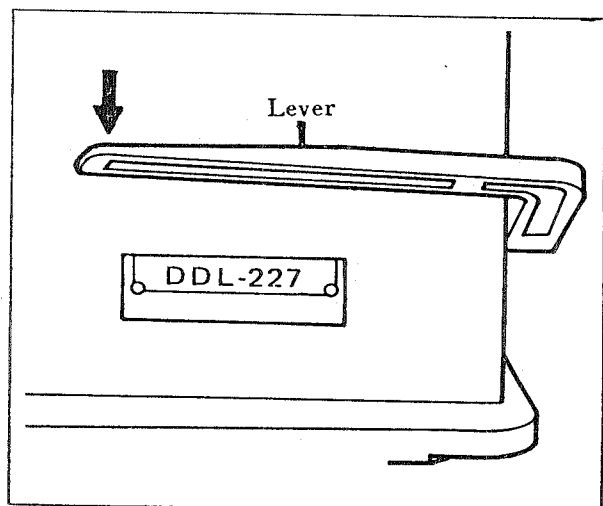

### Reverse sewing

1. For reverse sewing, push the feed lever down.
2. As long as this lever is kept down, reverse sewing can be performed.
3. Release this lever and the feed lever will return to original position and normal straight stitching can be resumed.

## INSERTING THE NEEDLE

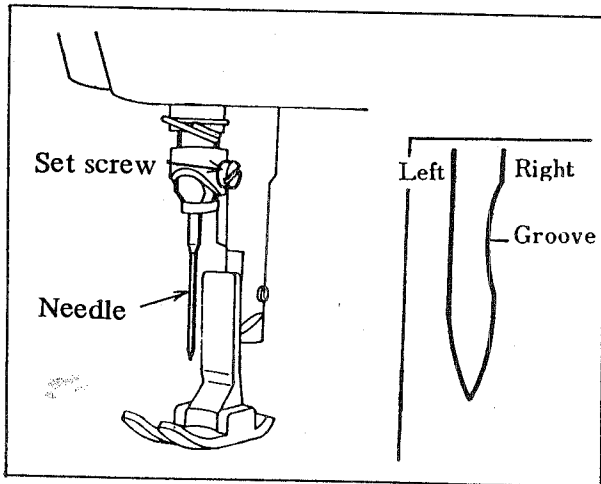

Use DB X 1 needles. There are many numbers and sizes of the needle, but select the correct size and number depending on the thickness of the thread or kinds of sewing material.

1. Rotate the hand wheel and bring the needle bar to the highest position.
2. Loosen the needle clamp screw.
3. Hold the needle so that the long groove of the needle comes to your left side.
4. Insert the needle deep into the needle hole
5. Then securely tighten the needle clamping screw.

## INSTALLING AND REMOVING THE SEWING HOOK

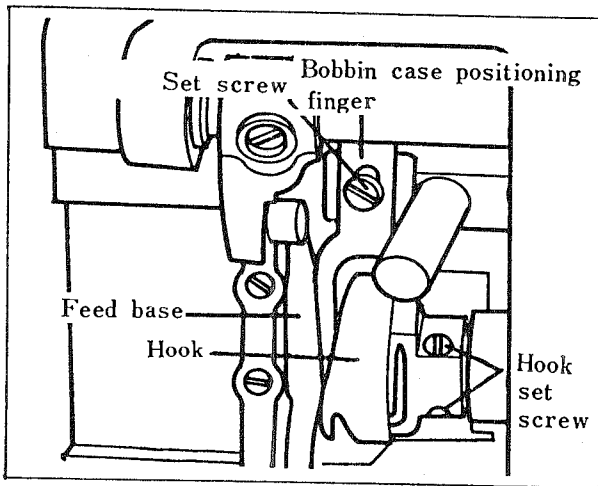

During the running of the machine, if thread hards get into the hook or the position of the hook changes for some reason or to exchange the hook with a new one, do as follows in order:

1. Rotate the hand wheel and bring the needle bar to the highest position.
  2. Remove the bobbin case and the needle.
  3. Remove the bobbin case base positioning finger set screw and take out the bobbin case positioning finger.
  4. Loosen the 3 screws of the sewing hook.
  5. Rotate the hand wheel and raise up the feed base to its highest position.
  6. Rotate the sewing hook with your hand and place it in the position as shown in the figure.
  7. Pull the hook to your left and take it out.
- \* To install the hook back, reverse this procedure.

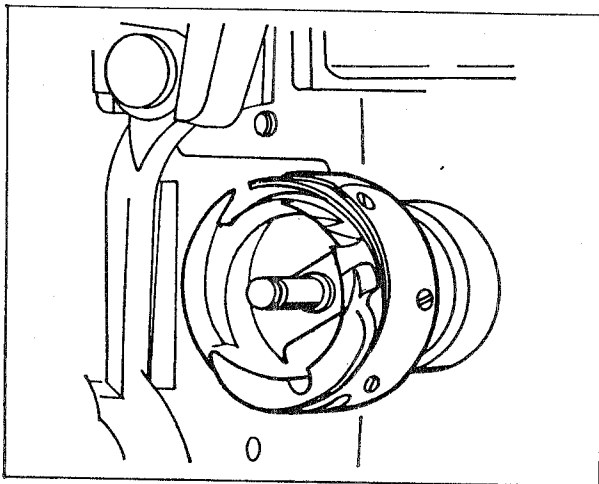

## RELATION BETWEEN THE HOOK AND THE NEEDLE

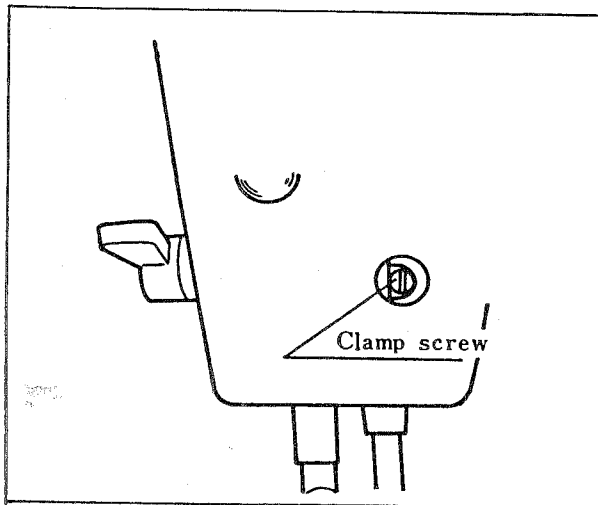

Match the needle with the sewing hook as follows:

1. Rotate the hand wheel and bring the needle bar to its lowest position.
2. Loosen the needle bar clamping set screw.

(Note)

When matching the timing of the needle and the sewing hook, be sure to set the feed adjusting dial to "0".

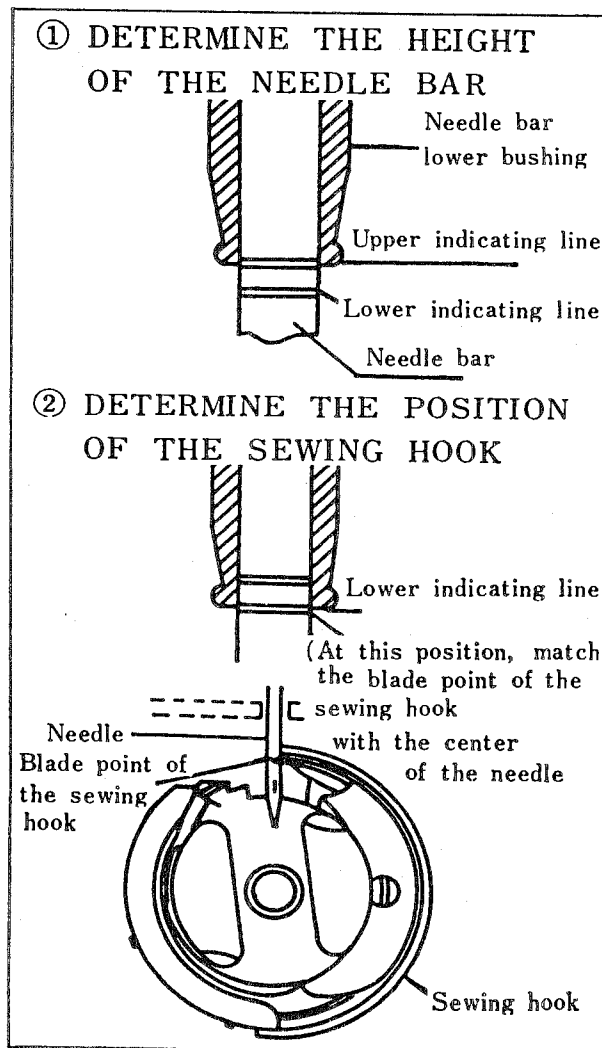

(Determine the height of the needle bar)

3. Match the upper carved line of the needle bar with the lower edge of the needle bar lower bushing.
4. Tighten the needle bar clamping set screw.

(Determine the position of the sewing hook)

5. Loosen the 3 clamping screws of the hook so that the hook can be rotated freely with the hand.
6. Place the hook with your hand to the thread passing position.
7. Rotate the hand wheel and match the lower carved line of the needle bar with the lower edge of the needle bar lower bushing.
8. In this condition, match the blade point of the hook with the center line of the needle
9. Make the clearance between the needle and the hook blade point to 0.05 mm and
10. Securely tighten the hook clamping set screw.

## ADJUSTING THE HEIGHT OF THE PRESSER BAR

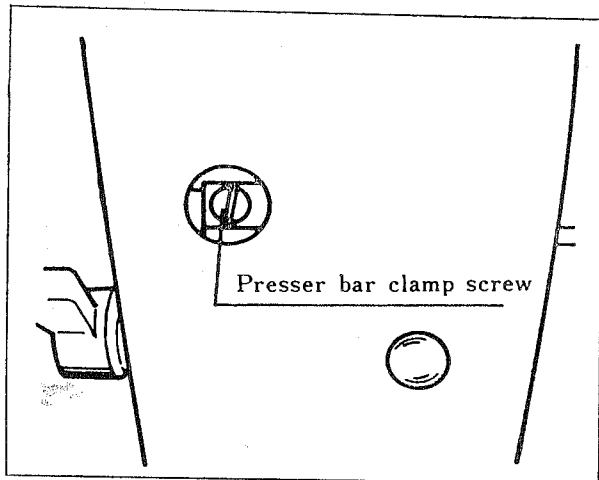

When the height or the direction of the presser bar is to be changed due to the exchange of presser foot:

1. Remove the rubber plug of the face plate.
2. From this hole, adjust by loosening the presser bar clamping screw.
3. After the adjustment, securely tighten the set screw.

## ADJUSTING THE AMOUNT OF THREAD TAKE-UP

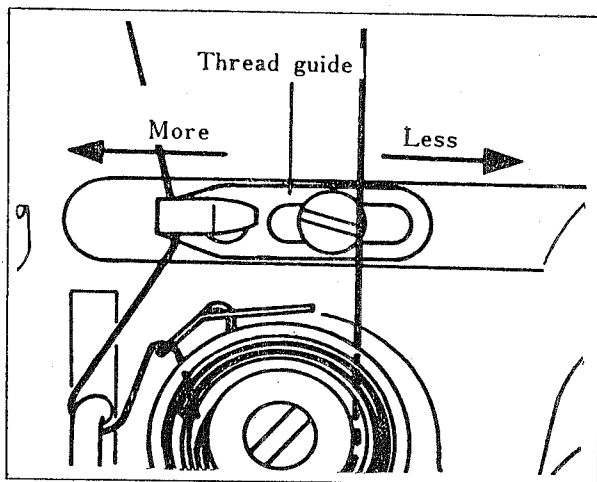

The amount of the thread take-up should be changed according to the length of stitches or thickness of the sewing cloth to produce ideal thread tension.

1. When sewing heavy weight materials, move the thread guide to your left.  
The thread take-up amount of the take-up gets more.
2. When sewing light weight materials, move the thread guide to your right.  
The thread take-up amount gets less.

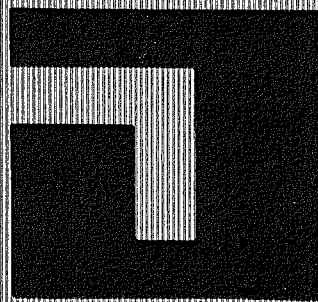

**TOKYO JUKI**

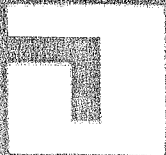

**TOKYO JUKI INDUSTRIAL CO., LTD.**

Head Office & Plant, 2-1, 8-chōme, Kokuryō-cho, Chōfu-shi, Tokyo, Japan

Business Office: 23, Kabuki-cho, Shinjuku-ku, Tokyo, Japan

Cable Address: JUKI TOKYO    Telex: 22967 JUKITK

**CD227 BEB Printed in Japan (T)**