

MODEL 204.1

Heat Seal Machines



PUT IT ON!®

FOR USE BY QUALIFIED SERVICE PERSONNEL ONLY

Congratulations!

Your selection of the Insta Graphic Systems (IGS) heat seal machine is a sound business decision. IGS equipment is the result of the highest quality engineering and time-tested design. Your new machine combined with IGS's reputation of innovation in the heat-sealing field, insures the continuing capability of delivering the best decorated substrates possible.

This manual describes installation, operation, and maintenance procedures for your new model machine, as well as easy to use instructions for on-the-spot maintenance.

Your machine will have a long trouble-free life. Read this manual. Keep it with your machine; it's your key to proper operation and lasting service.

Installation



DOMESTIC

Use a **separate** 15 amp AC circuit. Only industrial extension cords with proper wire size should be used: size 16/3 wire for distances up to 25 feet, and size 14/3 for distances up to 50 feet.



INTERNATIONAL

Use a **designated** 16 amp AC circuit. Only industrial extension cords with proper wire size (2.5 sq. mm) shall be used.

Limited Machine Warranty

Insta Graphic Systems (IGS) warrants this heat seal machine, when operated under normal conditions, to be free from manufacturing defects in material and workmanship for a period of one year on parts (lifetime on the upper heating element) and 90 days on labor from the invoice date.

This warranty will be effective only when IGS authorizes the original purchaser to return the product to the factory in Cerritos, California freight prepaid, and only when the product upon examination has proven to be defective.

This warranty does not apply to any machine that has been subjected to misuse, negligence or accident.

IGS shall not be liable for the injury, loss or damage, direct or consequential, arising out of the use or the inability to use the product.

No claim of any kind shall be greater in amount than the sale price of the product or part to which claim is made.

This is the sole warranty given by the company, it is in lieu of any other warranties, expressed or implied, in law or in fact, including the warranties of merchantability and fitness for a particular use, and is accepted as such by the purchaser in taking delivery of this product.

Specifications

Voltage **115/120 Volts AC** 50/60 Hertz
Model 204 14.6 Amps 1750 Watts

Voltage **230/240 Volts AC** 50/60 Hertz
Model 204 9.6 Amps 2200 Watts

Weight Model 204 94 Pounds (42.7 KG)

FOR USE BY QUALIFIED SERVICE PERSONNEL ONLY

Operation

1. It is recommended that you review the "How to Apply Instructions" (on our Product Information Sheet) before beginning heat sealing operations.
2. Turn the power on by pressing the **POWER** button on the controller.
3. Set desired temperature and time then swing the upper platen arm to its fully open position, away from lower platen.
4. Allow the machine to warm up until the selected temperature is reached.
5. Set the desired pressure by adjusting the pressure adjust handle on the top of the machine. To increase pressure, rotate handle counterclockwise.
6. Place the substrate on lower platen, smoothing out all wrinkles.
7. Position transfer or lettering on substrate.
8. Swing the upper arm into position directly over the lower platen.
9. Close machine by pulling handle down into locked position.
10. The timer will start automatically and a buzzer will beep at the end of the time cycle.
11. Lift safety lock and pull handle up slowly and move upper platen handle to its full open position. This technique will avoid transfer paper (cover) from being pulled off prematurely due to suction from the separating platens.

NOTE



For safety purposes, it is necessary to push the handle into the locked position after it is lifted. This will eliminate the accidental lowering of the heat platen handle.

12. Swing away arm to the extreme right hand position and remove substrate.

Operation Timer/Temperature Control



Solid State Controller

This controller has three (3) control features:

1. Temperature - Temperature may be set from 225-450°F (107-232°C).
2. Time - Time may be set from 1 second to 10 minutes.
3. Counter - Cycle counter counts the number of applications from 1 to 9999 (see additional Notes - Counter).

Controller Operation

1. If the temperature is not being displayed, press the **MODE** button until temperature is displayed.
2. Push and hold **SET** button and simultaneously push UP (↑) or DOWN (↓) arrow buttons to the desired temperature setting.
3. Press the **MODE** button until time is displayed.
4. Push and hold **SET** button and simultaneously push UP (↑) or DOWN (↓) arrow buttons to the desired timer setting.

FOR USE BY QUALIFIED SERVICE PERSONNEL ONLY

ADDITIONAL NOTES:

Temperature



NOTE

Fahrenheit/Centigrade (Celsius) Conversion

The temperature controller can be programmed to display either °F or °C.

To change:

*Press the **MODE** button until the temperature is displayed, then push and hold the **SET** button for 10 seconds.*

Timer

- The controller has a count down timer that automatically activates a buzzer at the completion of the application.
- Timer display is minutes:seconds. Range is **00:00** to **10:00**, Colons (:) flash while timer is running.



NOTE

The timer or buzzer may be stopped while the handle is in the down position by pressing both the DOWN (↓) arrow button and the UP (↑) arrow button simultaneously. The timer will automatically reset after the handle is raised.

Counter

The controller has a built in cycle counter.

- Press **MODE** button until the counter is displayed.
- Counter display range is 0000 to 9999.
- To reset the cycle counter, display the counter reading, then push and hold both UP (↑) and DOWN (↓) arrow buttons for 3 seconds until the counter resets to zero (**0000**) on the display.

FOR USE BY QUALIFIED SERVICE PERSONNEL ONLY

Safety Summary



WARNING

In case of power cord damage, do not attempt to repair or replace the power cord. Contact the manufacturer or the local distributor.



WARNING

Avoid touching hot surfaces while operating the machine.



CAUTION

During normal operation, the base of the machine needs to be installed or placed above the wall socket.



CAUTION

When servicing or cleaning the machine, make sure that the power cord is removed from the wall socket.

International Symbols



Power Off



Power On



Hot Surface



Risk of Electrical Shock



Protective Earth Terminal



Ground



Caution - Warning

Model:				
Part No.:			INSTA GRAPHIC SYSTEMS	
Serial No.:			5642 Borwick Avenue South Gate, CA 90280	
Volts:	Hz	Watts:	W	MFG: 2004
Made in U.S.A.		Service: (562) 861-2566		
www.instagram.com		(800) 426-3609		
Patent No:				

FOR USE BY QUALIFIED SERVICE PERSONNEL ONLY

Preventive Maintenance Suggestions

The IGS heat seal machines are relatively maintenance free. For long trouble-free life, the following preventive maintenance should be followed:

1. Do not heat seal items such as buttons, pins, snaps, or zippers that tend to cut the silicone rubber pad or scratch the Teflon heat platen.
2. Periodically clean the Teflon-coated heat platen with a non-abrasive piece of cloth. Stubborn stains may be cleaned, **when platen is cool**, with mineral spirits.
3. When the heat platen is hot and not in use, keep in open position (away from the silicone rubber pad).
4. To prevent soiling of substrate, periodic wiping of the entire exterior machine, including platens, with a clean rag is recommended. If necessary, use mineral spirits for cleaning a **cold** machine. Since mineral spirits are flammable, use precautions and keep away from sparks, flame, or hot heat platen.
5. This machine requires periodic lubrication with a high-temperature, non-melting grease (MPPL023).
 - A. Lubricate the post, handle and cam assembly depending upon usage. (Once every month if used continuously.)
 - B. There are four (4) points of lubrication:
 - a) Post
 - b) Lower Cam
 - c) Guide Post
 - d) Upper Pin Area

In addition, occasionally apply a few drops of heavy machine oil to the upper portion of the cam assembly. To lubricate the pressure adjustment, raise cover put some high-temperature grease MPPL023 grease on the treaded section of the adjustment screw.



NOTE

*Wipe off any excess oil or grease.
Replace cover, screw, and knob.*

General Maintenance

It is recommended that you have the following items available:

- A. Regular screw driver
- B. Phillips head screw driver
- C. Small adjustable wrench
- D. Needle nose pliers with insulated handle
- E. Set of Allen wrenches
- F. Grease gun
- G. Special high temperature grease (MPPL023)

With the above items you should be able to accomplish most repairs.



WARNING

Power cord replacement should be from the manufacturer only (because it requires a specially prepared cord).

Replacement of Silicone Rubber Pads

1. Make sure heat platen is cool.
2. Use tube of MPPC006 adhesive to bond silicone rubber pad to metal platen.
NOTE: *Read instructions on the tube package.*
3. Be sure that the surface of the silicone platen is clean. Use a **mild** solvent such as **mineral spirits**.
4. The pad and metal must be thoroughly dry and clean, before starting the bonding operation.
5. Apply adhesive sealant to the metal platen. Spread a thin even coat and apply pad immediately. Apply pressure and position pad making sure that there is no air entrapment.
NOTE: *A serrated blade such as used for laying down rubber floor tiles would be helpful.*
6. Allow to cure overnight under low pressure at normal room temperature.

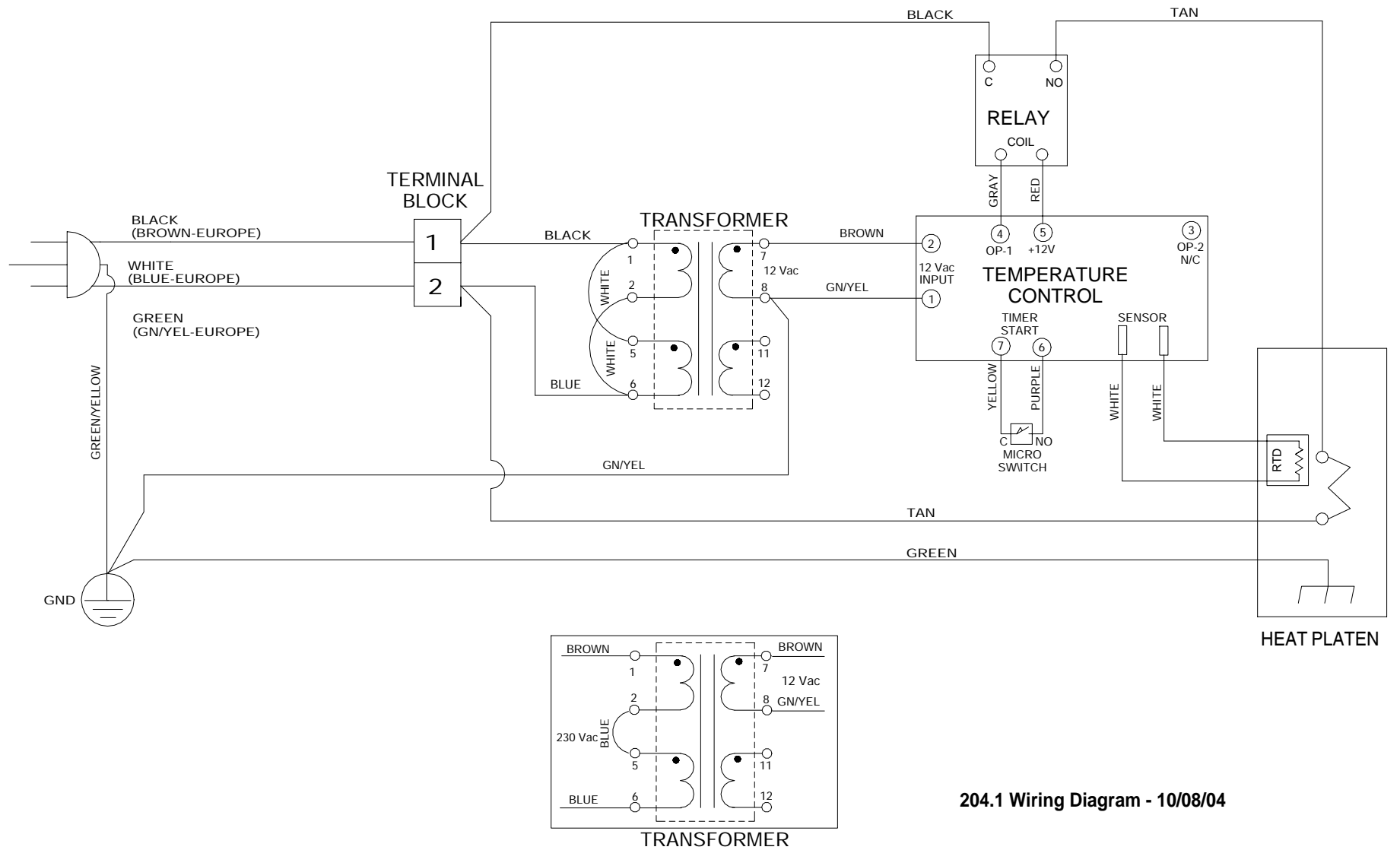

204.1 Wiring Diagram - 10/08/04

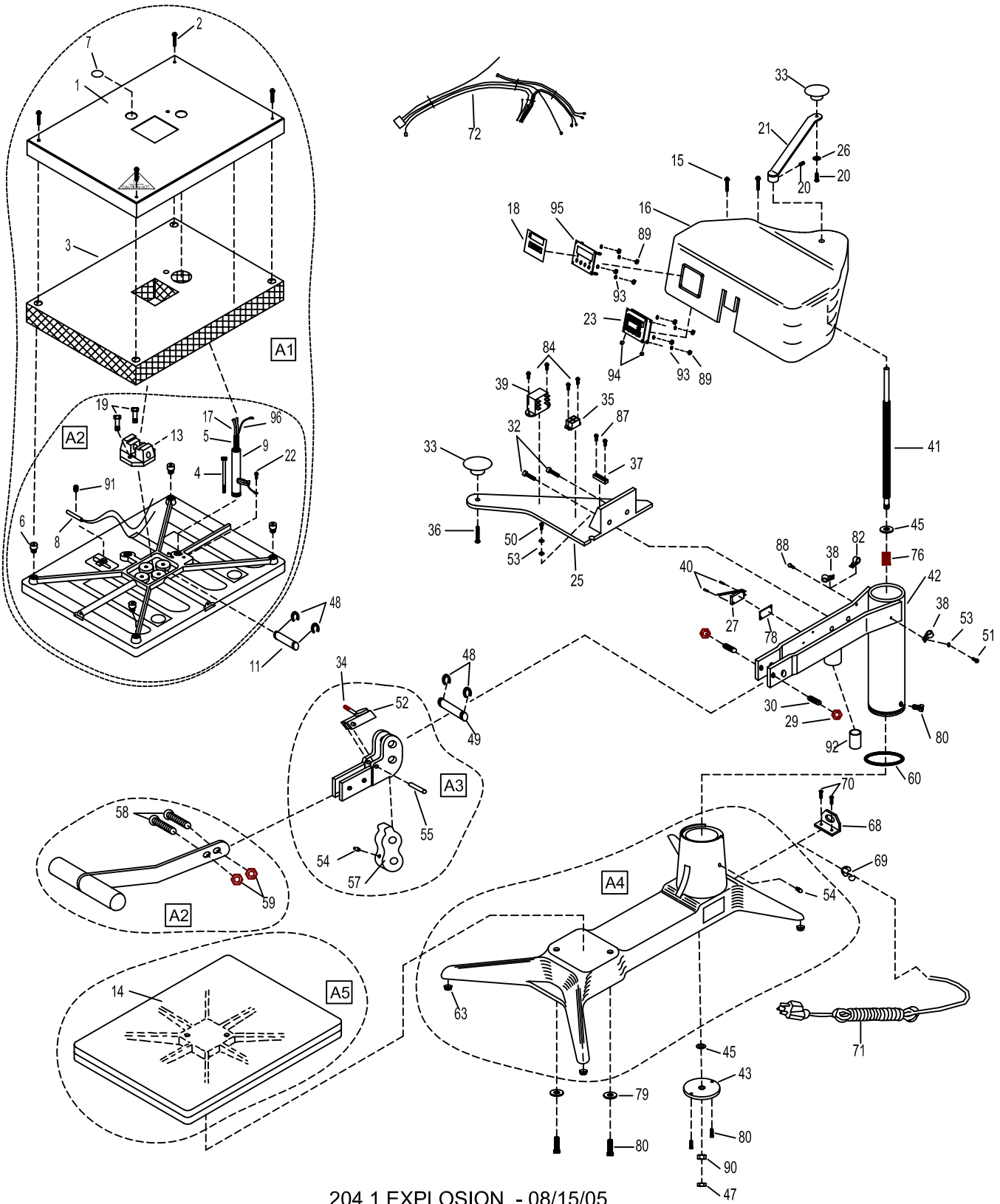

204.1 EXPLOSION - 08/15/05

		MODEL	MODEL
		204.1	204.1
NO	DESCRIPTION	120V AC	230V AC
1	SHROUD, HEAT	MPSS228	MPSS228
2	SCREW, PAN HD #10 X 1.00" LG	MPSS143	MPSS143
3	INSULATION, FIBERGLASS 15X20	MPSP254	MPSP254
4	SCREW, SOCKET HD 1/4-20 X 4 LG	MHSSH14204	MHSSH14204
5	TUBING, SHRINK TFE AWG7	MPPS131	MPPS131
6	INSULATORS, SPACER (4/SET)	MPSI089	MPSI089
7	PLUG, BUTTON 7/8 IN	MHPB78	MHPB78
8	SENSOR, TEMP. REPLACEMENT KIT	MPPS210	MPPS210
9	POST, GUIDE	MPSP084	MPSP084
11	PIN, PIVOT PLATEN	MPP0139	MPP0139
13	CLEVIS, UPPER PLATEN	MPSP221	MPSP221
14	PAD, SILICONE 15 X 20 BLK	MPPP031	MPPP031
15	SCREW, PAN 10-24 X .50 LG	MHSP102412	MHSP102412
16	HOUSING, INSTRUMENT	MPSH015	MPSH015
17	WIRE, HEATER 14GA TGGT	MPPW700	MPPW700
18	LABEL, CONTROLLER OVERLAY	MPSL128	MPSL128
19	BOLT, HEX 5/16-18 X 1 LG STAINLESS	MHBH516181S	MHBH516181S
20	SCREW, BUT HD 1/4-20 X .75" LG	MHSB142034	MHSB142034
21	HANDLE, PREASURE ADJUST F/204	MPSP014	MPSP014
22	SCREW, PAN HD 6-32 x 0.25 IN	MHSP63214	MHSP63214
23	CONTROLLER, DIGITAL W/SWITCH	MPC90003	MPC90003
25	HANDLE, SWINGAWAY 218A 228A	MPH90002	MPH90002
26	WASHER, SAE 1/4"	MHWSAE14	MHWSAE14
27	SWITCH, MICRO	MPPS043	MPPS043
29	NUT, HEX 3/8-16 LOCKING	MHNNH3816	MHNNH3816
30	PLUNGER SPRING DETENT 500	MPSP134	MPSP134
32	SCREW, SKT. HD 1/4-20 X.625 HD	MHSSH142058	MHSSH142058
33	KNOB, HANDLE (MUSHROOM)	MPPK017	MPPK017
34	CAP, VINYL BLK 5/16X.281 LG	MPC90006	MPC90006
35	RELAY	MPPR200	MPPR200
36	SCREW, BTN HD 1/4-20 X .875LG	MHSB142078	MHSB142078
37	BLOCK, TERMINAL	MH11096914	MH11096914
38	CLAMP, CABLE 5/16 IN.	MHCC516	MHCC516
39	TRANSFORMER	MPPT700	MPPT700
40	SCREW, RD HD 4-40X.625" LG	MHSR44058	MHSR44058
41	SCREW, PRESSURE ADJUSTMENT	MPSS070	MPSS070
42	POST, ARM ASSY	MPSP204	MPSP204
43	PLATE, POST STOP	MPSP20450	MPSP20450
45	WASHER, SAE 1/2"	MHWSAE12	MHWSAE12
47	NUT, JAM SELF LOCKING 1/2-20	MHNNHJSL1220	MHNNHJSL1220
48	CLIPS, "E"	MPSC240	MPSC240
49	PIN, CAM PIVOT (UPPER)	MPSP262	MPSP262
50	SCREW, PAN HD 8-32 X .375" LG	MHSP83238	MHSP83238
52	SAFETY LOCK	MPSL241	MPSL241
53	WASHER, #8 SAE	MHWSAE8	MHWSAE8
54	FITTING, GREASE (SHORT)	MPSF145	MPSF145
55	PIN, ROLL (SAFETY LOCK)	MPSR141	MPSR141

57	CAM	MPSC220	MPSC220
58	SCREW, BUTTON HD 5/16-18 X1 LG	MHSB516181	MHSB516181
59	NUT, HEX JAM 5/16-18	MHNHJ51618	MHNHJ51618
60	RING, "O" POST	MPSS273	MPSS273
63	FEET,RUBBER (6/SET)	MPF90004	MPF90004
68	BRACKET, POWER CORD	MPSS163	MPSS163
69	STRAIN RELIEF 14/3	MPSS168	MPSS168
70	SCREW, PAN HD 10-24 X .375 LG	MHSP102438	MHSP102438
71	CORD, POWER (USA)	MPPW141	MPPW142
71A	CORD, POWER (EUROPEAN) 230V	N/A	MPPW202
71B	CORD, POWER (U.K) 240V	N/A	MPPW203
72	WIRE, HARNESS	MPW90011	MPW90011
76	SPRING, CAM	MPSS201	MPSS201
78	INSULATION, MICRO SWITCH	MH700214	MH700214
79	WASHER, CUT 5/16"	MHWC516	MHWC516
80	SCREW, SKT HD 5/16-18 X .50 LG	MHSSH5161812	MHSSH5161812
82	CLAMP, CABLE 3/8" (STEEL)	MH8863T2	MH8863T2
84	SCREW, PAN HD 8-32 X 1/4 LG	MHSP83214	MHSP83214
87	SCREW, PAN HD 8-32 X 1/2 LG	MHSP83212	MHSP83212
88	SCREW, SOCKET HD 1/4-20 0.5 LG	MHSSH142012	MHSSH142012
89	NUT, HEX 6-32	MHNH632	MHNH632
90	NUT, JAM 1/2-20	MHNHJ1220	MHNHJ1220
91	SCREW, SET 3/8-16 X .500 LG	MHSST381612	MHSST381612
92	BUSHING, GUIDE POST	MPSB074	MPSB074
93	WASHER, SHIM #6 (.031)	MH311150019	MH311150019
94	SPACER, NYLON 0.166 ID X1/4 LG	MH110969111	MH110969111
95	PLATE, CONTROLLER	MPP90011	MPP90011
96	WIRE, GROUND ASS'Y	MPW90125	MPW90125
A1	PLATEN, HEAT ASS'Y	MPP2041A	MPP2042A
A2	HANDLE, PRESSURE ASS'Y	MPSH515	MPSH515
A3	CAM ASS'Y	MPSC213	MPSC213
A4	BASE ASSEMBLY	MPSB204A	MPSB204A
A5	PLATEN, LOWER ASSY	MASP007	MASP007
A6	PLATEN, HEAT W/WIRNG	MPP2041W	MPP2042W

INSTA GRAPHIC SYSTEMS®

13925 E. 166th Street • Cerritos CA USA 90702-7900

Service: (800) 426-3609 • Fax: (562) 861-1519 • (562) 861-2566 • Sales: (800) 421-6971 (562) 404-3000 • Fax: (562) 404-3010

<http://www.instagramh.com>