

MISCELLANEOUS COVERS (1)

Ref. No.	Parts No.	Description	品名	1 Amt. Req.
1	2100006	Cloth Plate	クロスプレート	1
2	2100013	Cloth Plate (Lower)	クロスプレート(下)	1
3	2100014	Rubber Cushion	クロスプレート(下)埋メ座	1
4	001123	Washer	ワッシャ	5
5	110045	Screw (M4-0.7×12)	止ネジ	3
6	2100011	Cloth Plate Eccentric Bushing	エキセンブッシュ	1
7	160001	Screw (M4-0.7×4)	止ネジ	1
8	2100012	Collar (4×9×6mm)	ヒンジピンカラー	1
9	003637	Screw (1/8-44×2.5)	止ネジ	1
10	2100008	Cloth Plate Spring	クロスプレートバネ	1
11	110012	Screw (M4-0.7×5)	止ネジ	2
12	100001	Lock Nut	ロックナット	1
13	110010	Stop Screw (M4-0.7×16)	ストップネジ	1
14	0020004	Oil Cap	オイルキャップ	1
15	0020005	O-ring (P28)	Oリング	1
16	2100053	Top Cover	上カバー	1
17	110016	Screw (M4-0.7×15)	止ネジ	6
18	2100054	Top Cover Gasket	上カバーパッキン	1
19	2100001	Machine Frame	フレーム	1
20	2100003	Oil Reservoir Gasket	油受ケパッキン	1
21	2100002	Oil Reservoir	油受ケ	1
22	006816	Screw (1/4-24×8)	止ネジ	4
23	0032879	Oil Reservoir Rubber Cushion (Black-colored)	防振ゴム(黒色)	3
24	0033627	Oil Reservoir Rubber Cushion (Green-colored)	防振ゴム(緑色)	1
25				
26	2100059	Oil Reservoir Positioning Bar	油受ケ固定棒	4
27	300004	Washer	ワッシャ	4
28	120017	Screw (M5-0.8×15)	止ネジ	4
29	0020137	Drain Hole Seal	パッキン	1
30	005075	Drain Hole Screw (3/8-24×8)	油抜キネジ	1
31	000644	Spring Washer	スプリングワッシャ	3
32				
33	330014	Seal Pulg	詰栓	1

(注) カラーの寸法は内径×外径×幅を表しています。
 Note: Size of Collar ... Inside dia. × Outside dia. × Thickness



(注) 型式板を別注文の際は機種名(ブレード型等)と数量を含むをお知らせ下さい。
 Note: Order for Model Plate must be accompanied by model designation (including symbols of gauge and devices).

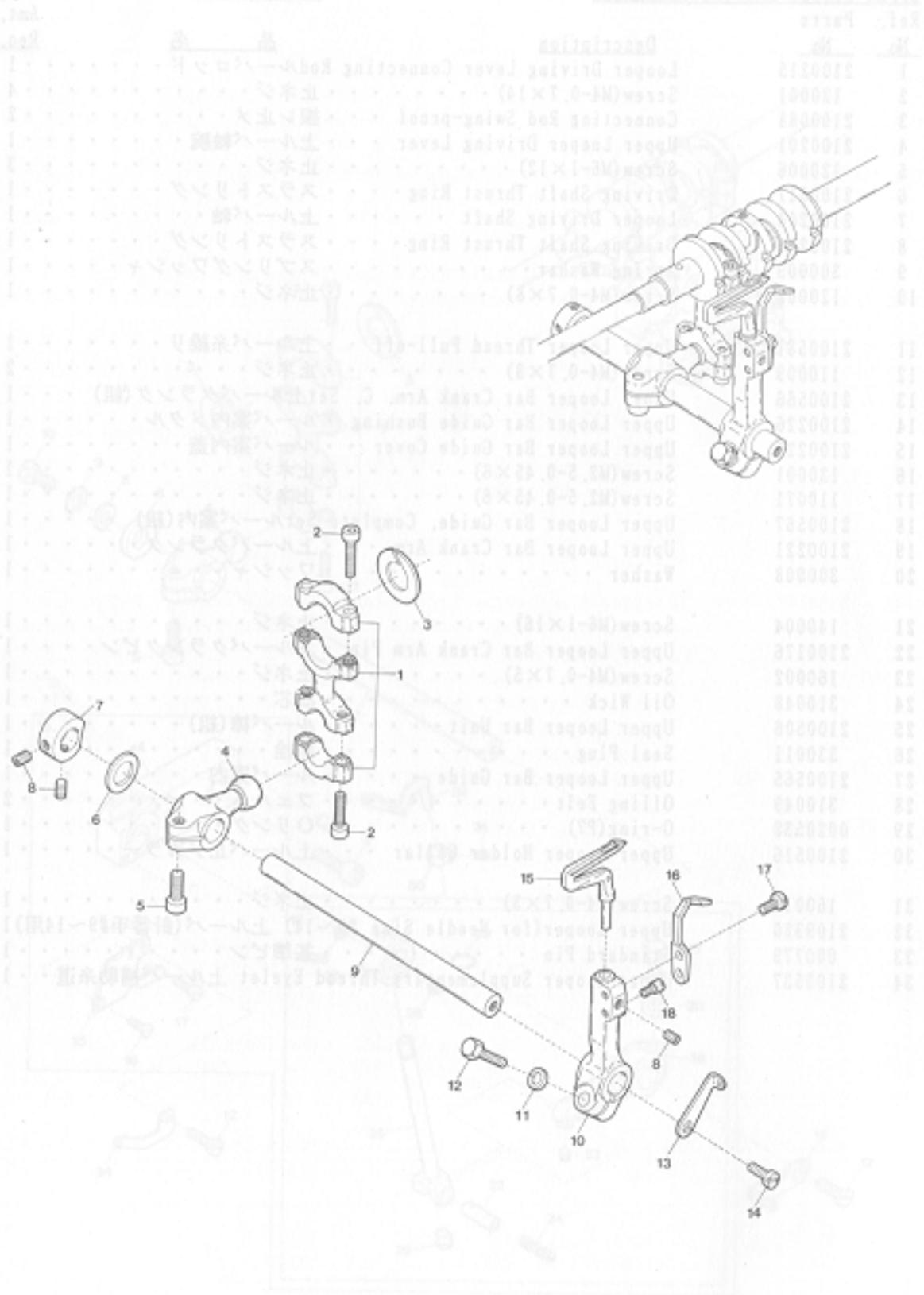

Ref. No	Parts No	Description	品名	Ant. Req.
1	2100215	Looper Driving Lever Connecting Rod	ルーバロッド	1
2	120001	Screw(M4-0.7×14)	止ネジ	4
3	2100088	Connecting Rod Swing-proof	振れ止め	1
4	2100210	Lower Looper Driving Lever	下ルーバ軸腕	1
5	120006	Screw(M6-1×12)	止ネジ	1
6	2100218	Driving Shaft Thrust Ring	スラストプレート	1
7	2100273	Collar(10×19×9mm)	ルーバ軸カラー	1
8	160003	Screw(M5-0.8×5)	止ネジ	3
9	2100219	Looper Driving Shaft	ルーバ軸	1
10	2100211	Lower Looper Holder Arm	下ルーバ台	1
11	300008	Washer	ワッシャ	1
12	140002	Screw(M6-1×14)	止ネジ	1
13	2100522	Thread Pull-off	下ルーバ台糸繰り	1
14	110009	Screw(M4-0.7×8)	止ネジ	1
15	2109300	Lower Looper	下ルーバ	1
16	2109201	Needle Guard(Rear)	針受ケ(後)	1
17	110036	Screw(M3-0.5×6.5)	止ネジ	1
18	180014	Screwed Pin(M3-0.5×4.5)	ピンネジ	1

(注) カラーの寸法は内径×外径×幅を表しています。
 Note: Size of Collar ... Inside dia. × Outside dia. × Thickness



(注) カラーの寸法は内径×外径×幅を表しています。
 Note: Size of Collar ... Inside dia. × Outside dia. × Thickness

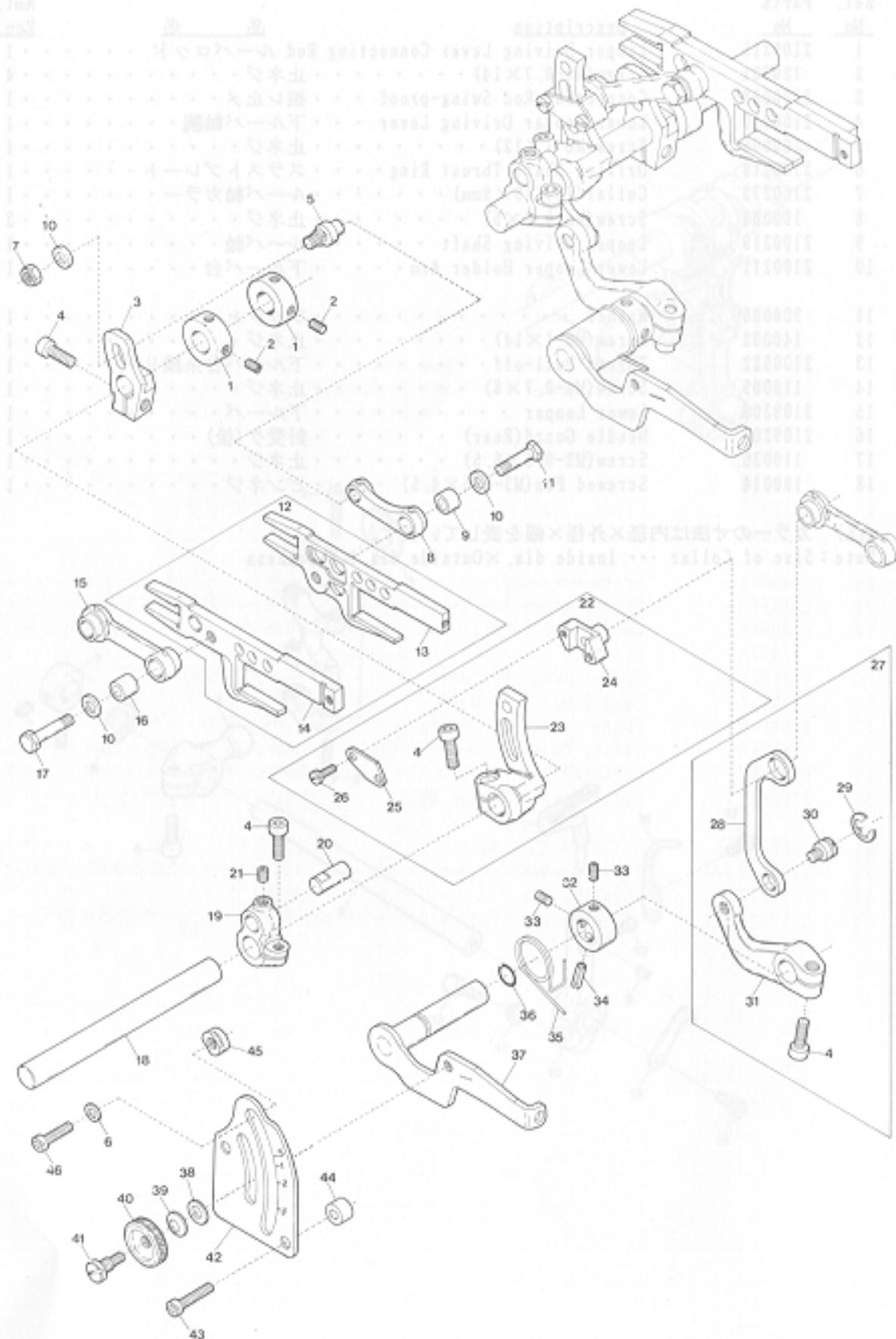

FEED DRIVING CONTROL MECHANISM

前送り調節機構

11

Ref. No.	Parts No.	Description	品名	Ant. Req.
1	2100161	Collar(10×19×9mm)	送り軸カラー	2
2	160003	Screw(M5-0.8×5)	止ネジ	4
3	2100250	Main Feed Bar Lever	後送りレバー	1
4	120006	Screw(M6-1×12)	止ネジ	4
5	2100251	Main Feed Bar Lever Pin	後送りレバーピン	1
6	000669	Washer	ワッシャ	2
7	100002	Nut	ナット	1
8	2100248	Main Feed Bar Connection	後送りリンク	1
9	2100249	Connection Bushing	後送りリンクブッシュ	1
10	300000	Washer	ワッシャ	3
11	140001	Screw(M5-0.5×12)	止ネジ	1
12	2100266	Feed Bar, Complete Set	前後送り台(組)	1
13	2100242	Main Feed Bar	後送り台	1
14	2100241	Differential Feed Bar	前送り台	1
15	2100243	Differential Feed Bar Connection	前送りリンク	1
16	2100244	Connection Bushing	前送りリンクブッシュ	1
17	140000	Screw(M5-0.5×15.5)	止ネジ	1
18	2100260	Feed Bar Driving Shaft	送り軸	1
19	2100240	Feed Bar Driving Shaft Lever	送り軸腕	1
20	2100288	Connecting Rod Pin	送りロッドピン	1
21	160007	Screw(M6-1×6)	止ネジ	1
22	2100033	Differential Rocker, Complete Set	前送り腕(組)	1
23	2100245	Differential Rocker	前送り腕	1
24	2100246	Differential Regulating Slider	スライダ	1
25	2100247	Differential Regulating Slider Cap	スライダ蓋	1
26	110033	Screw(M3-0.5×6)	止ネジ	2
27	2100269	Differential Lever(Right), C. Set	差動レバー(右)(組)	1
28	2100252	Slider Link	スライダリンク	1
29	0068202	Retaining Ring	ストップリング	1
30	2100253	Slider Link Pin	スライダリンクピン	1
31	2100262	Differential Lever(Right)	差動レバー(右)	1
32	2100267	Collar(10×17×8mm)	差動レバー軸カラー	1
33	160001	Screw(M4-0.7×4)	止ネジ	2
34	000690	Roll Pin	ロールピン	1
35	2100256	Differential Lever Spring	差動レバーバネ	1
36	0020538	O-ring(P7)	Oリング	1
37	2100263	Differential Lever(Left)	差動レバー(左)	1
38	000520	Washer	ワッシャ	1
39	000561	Conical Spring Washer	皿バネワッシャ	1
40	100000	Adjusting Nut	調節ナット	1
41	190001	Adjusting Screw(M6-1×11.5, M4.5-0.5×4)	調節ネジ	1
42	2100601	Differential Feed Graduation	送り目盛板	1
43	110016	Screw(M4-0.7×15)	止ネジ	2
44	2100265	Spacer	スペーサ	2
45	0020350	Differential Lever Stop	差動レバーストップ	2
46	110017	Screw(M5-0.8×8)	止ネジ	2

(注) カラーの寸法は内径×外径×幅を表しています。
 Note: Size of Collar ... Inside dia. × Outside dia. × Thickness

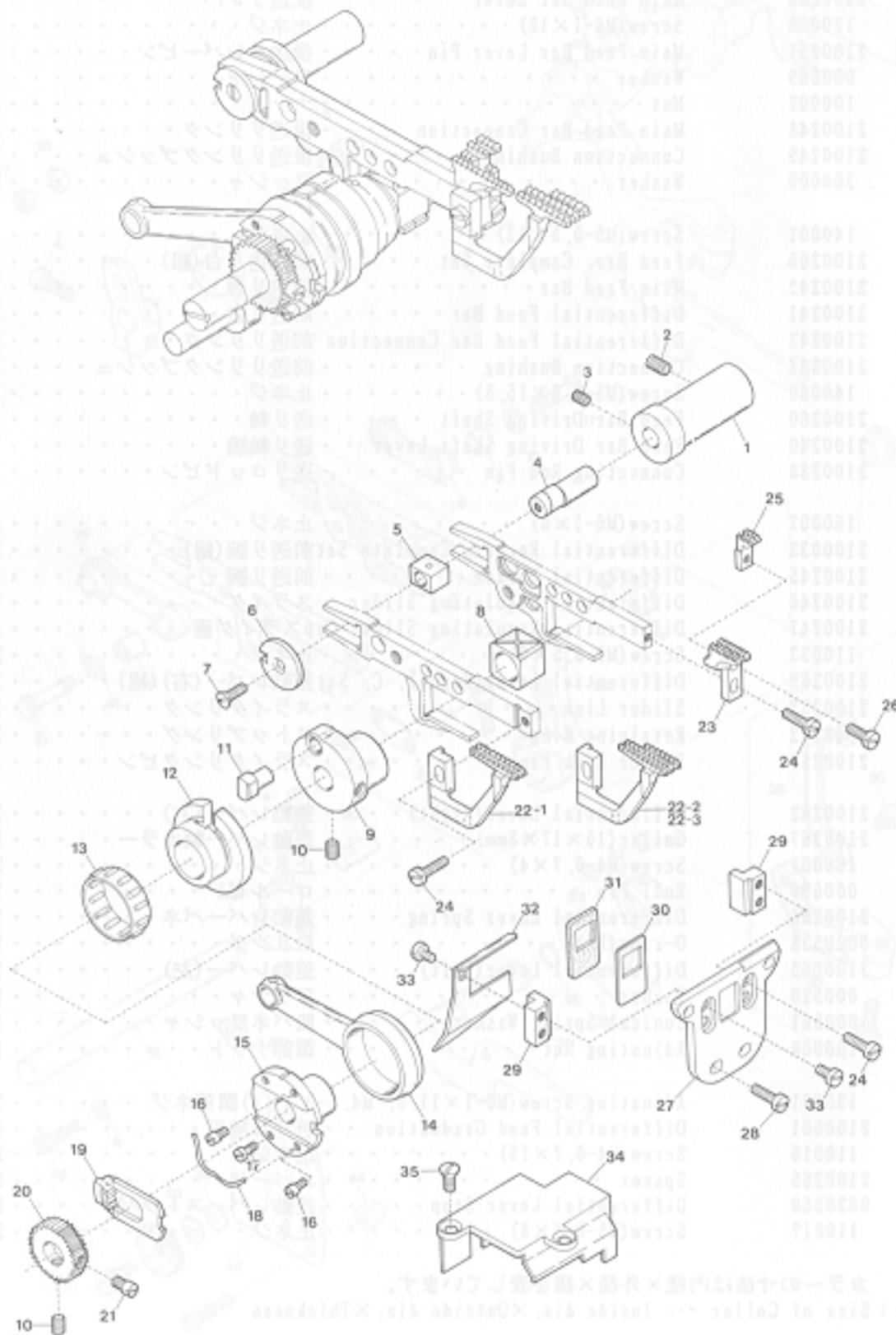

FEED DRIVING MECHANISM

Ref. No.	Parts No.	Description	品名	Amt. Req.
1	2100603	Feed Bar Block(Rear) Shaft Bushing	角駒(後)軸ブッシュ	1
2	160007	Screw(M6-1×6)	止ネジ	1
3	160001	Screw(M4-0.7×4)	止ネジ	1
4	2100602	Feed Bar Block(Rear) Shaft	角駒(後)	1
5	2100283	Feed Bar Block(Rear)	角駒(後)	1
6	2100281	Feed Bar Block(Rear) Lid	角駒(後)蓋	1
7	130002	Screw(M3-0.5×6)	止ネジ	1
8	2100280	Feed Bar Block(Front)	角駒(前)	1
9	2100284	Eccentric Pin Holder	送りエキセンピン取付台	1
10	160003	Screw(M5-0.8×5)	止ネジ	3
11	0020401	Feed Dog Eccentric Pin	送りエキセンピン	1
12	2100277	Feed Dog Eccentric	送りエキセン	1
13	2100278	Roller Bearing	ニードルベアリング	1
14	2100275	Feed Dog Driving Connecting Rod	送りロッド	1
15	2100276	Feed Dog Regulating Eccentric	送り調節エキセン	1
16	180002	Screw(M3-0.5×4)	止ネジ	2
17	110070	Screw(M3-0.5×6.3)	止ネジ	1
18	2100289	Feed Dog Regulating Plate Spring	送り調節プレートバネ	1
19	0023473	Feed Dog Regulating Plate	送り調節プレート	1
20	2100279	Feed Dog Regulating Gear	送り調節ギア	1
21	180003	Screw(M5-0.8×8)	止ネジ	1
22-1	2109007	Differential Feed Dog(03)	前送り(03)	1
22-2	2109005	" " (04, 05)	" (04, 05)	1
22-3	2109009	" " (06)	" (06)	1
23	2109006	Main Feed Dog	後送り	1
24	110004	Screw(M3.5-0.6×8)	止ネジ	5
25	2109067	Auxiliary Feed Dog	小送り	1
26	110026	Screw(M3-0.5×6)	止ネジ	1
27	2100631	Feed Bar Guide Support	送り台ガイドサポート	1
28	110064	Screw(M4-0.7×8)	止ネジ	4
29	2100632	Feed Bar Guide	送り台ガイド	2
30	2100285	Feed Bar Shield(Front)	送り台シール(前)	1
31	2100286	Feed Bar Shield(Rear)	送り台シール(後)	1
32	2100302	Feed Bar Oil Defender	送り台油除ケ	1
33	110042	Screw(M3.5-0.6×4)	止ネジ	2
34	2100301	Connecting Rod Cover	送りロッドカバー	1
35	130003	Screw(M4-0.7×7.3)	止ネジ	2

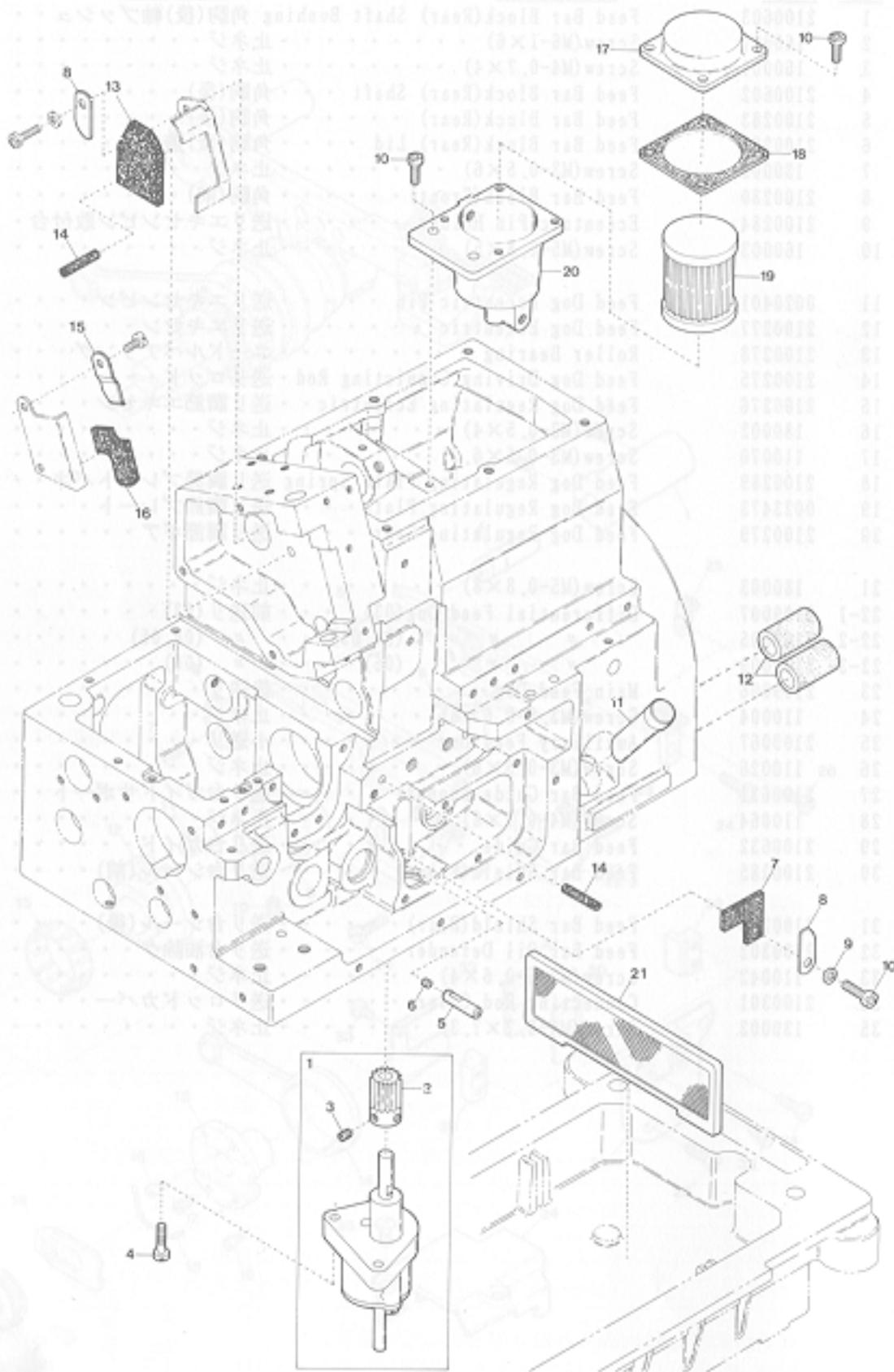

LUBRICATING MECHANISM(1)

Ref. No.	Parts No.	Description	品名	Ant. Req.
1	2100365	Oil Pump, Complete Set	ポンプ(組)	1
2	2100363	Worm Wheel	ウオームホイール	1
3	160001	Screw(M4-0.7×4)	止ネジ	2
4	110016	Screw(M4-0.7×15)	止ネジ	2
5	2100645	Oil Pipe	オイルパイプ	1
6	000456	Seal Plug	詰栓	1
7	2100646	Upper Looper Bar Oiling Felt	ルーパフェルト	1
8	2100255	Oil Adjusting Plate	油量調節板	2
9	000538	Washer	ワッシャ	1
10	110013	Screw(M4-0.7×8)	止ネジ	7
11	2100032	Oil Sight Gauge	オイルゲージ	1
12	2100605	Seal Plug	詰栓	2
13	2100142	Needle Bar Oiling Felt	針棒フェルト	1
14	310023	Oil Wick	油芯	2
15	2100524	Oiling Felt Clamp	針棒フェルト押エ	1
16	2100523	Needle Bar Oiling Felt(Left)	針棒フェルト(左)	1
17	2100315	Filter Housing Cover	フィルタハウジング蓋	1
18	2100316	Filter Housing Gasket	フィルタハウジングパッキン	1
19	3100345	Filter	フィルタ	1
20	2100314	Filter Housing	フィルタハウジング	1
21	2100383	Oil Filter Screen	伊過網	1

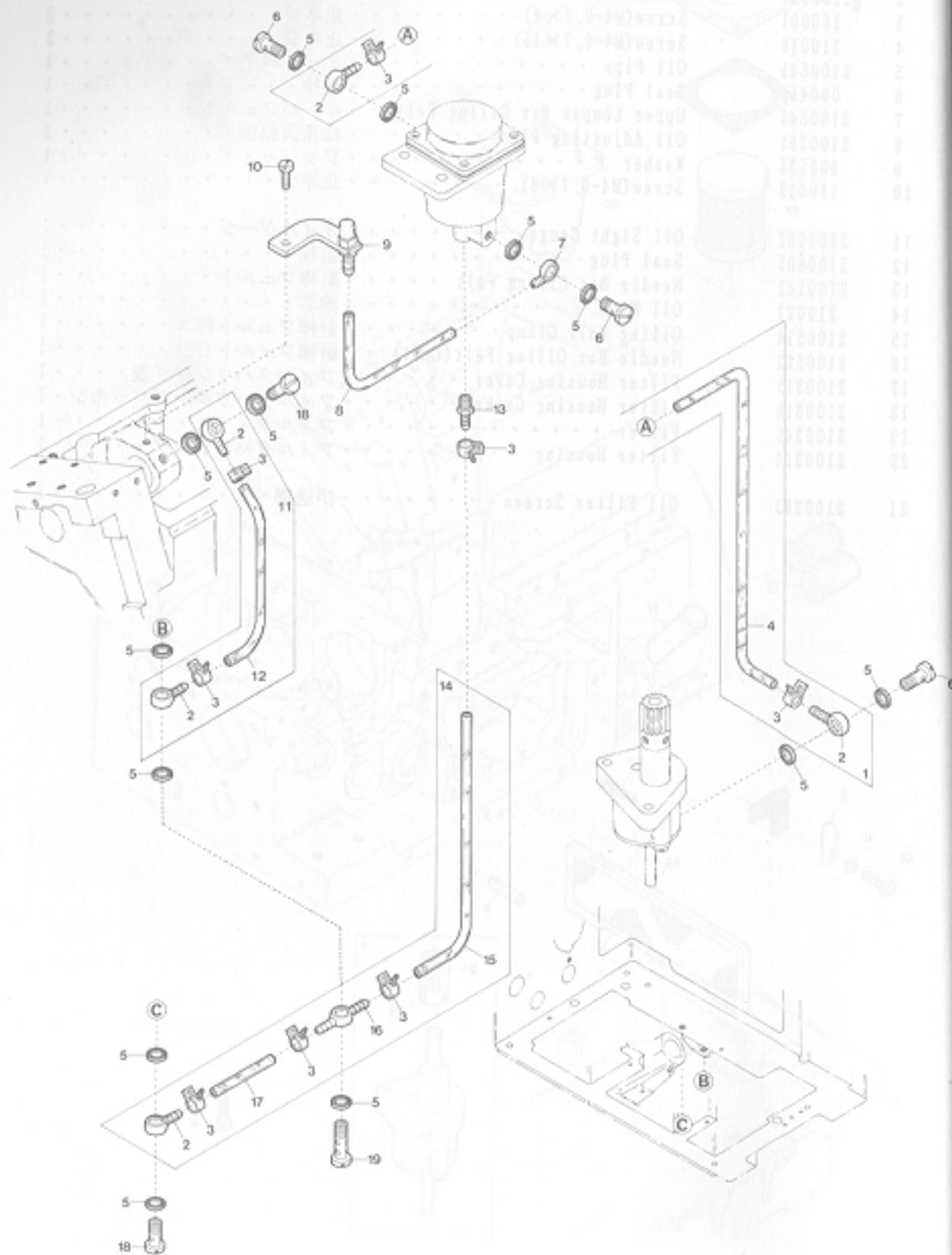

LUBRICATING MECHANISM(2)

給油機構(2)

Ref. No.	Parts No.	Description	品名	Req. Amt.
1	2100626	Oil Tube, Complete Set	給油パイプ(組)	1
2	0037669	Oil Tube Fitting One Way End	片口管継手	5
3	0031831	Oil Tube Clamp	緊束環	8
4	2100607	Oil Tube(4.6×6.4×170mm)	給油パイプ	1
5	000567	Seal	パッキン	13
6	320000	Oil Tube Fitting Stud	管継手ボルト	3
7	320001	Oil Tube Fitting One Way End	片口管継手	1
8	2100325	Oil Tube(2.5×4×100mm)	給油パイプ	1
9	2100541	Oil Nozzle Unit	給油ノズル(組)	1
10	110012	Screw(M4-0.7×5)	止ネジ	1
11	2100634	Oil Tube, Complete Set	給油パイプ(組)	1
12	2100633	Oil Tube(4.6×6.4×265mm)	給油パイプ	1
13	009909	Oil Tube Joint	パイプ継手	1
14	2100546	Oil Tube, Complete Set	給油パイプ(組)	1
15	2100384	Oil Tube(4.6×6.4×215mm)	給油パイプ	1
16	0037668	Oil Tube Fitting Two Way	両口管継手	1
17	2100341	Oil Tube(4.6×6.4×38mm)	給油パイプ	1
18	320002	Oil Tube Fitting Stud	管継手ボルト	2
19	320003	Oil Tube Fitting Stud(Long)	管継手ボルト(長)	1

UPPER KNIFE(Angled Type)

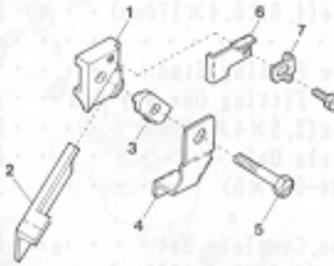

AZ6000H

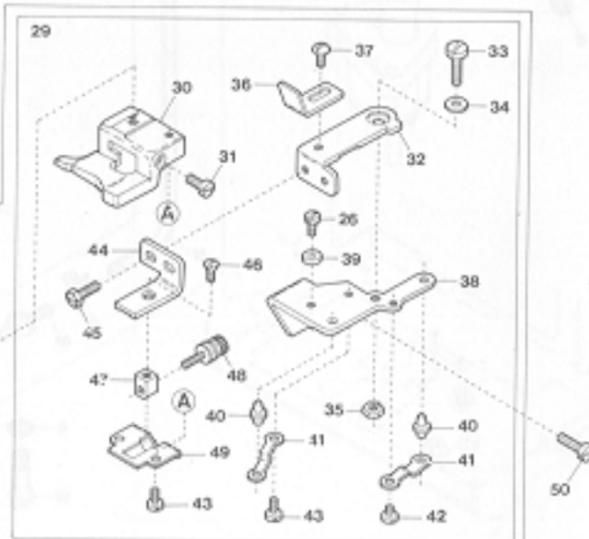
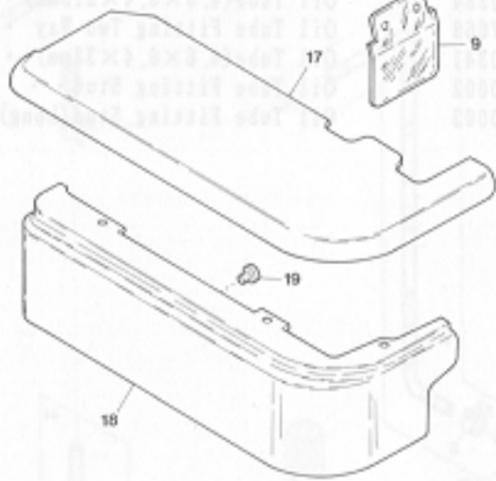
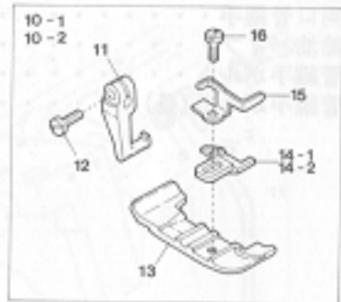

EXCLUSIVE PARTS for UPPER KNIFE(Angled Type), AZ6000H 角メス及び押エ付部

Ref. No	Parts No	Description	品名	Amt.	Req.
1	2100350	Upper Knife Holder	上メスホルダ(角)	1	1
2	0020491	Upper Knife	上メス	1	1
3	2101435	Upper Knife Clamp	上メス押エ	1	1
4	2100354	Upper Knife Chip Guard	切屑押シ	1	1
5	140012	Screw(M4-0.7×18.5)	止ネジ	1	1
6	2100352	Upper Knife Clamp Plate	上メス押エ受ケ	1	1
7	2100353	Upper Knife Stop	上メスストップ	1	1
8	110038	Screw(M2.5-0.45×4.5)	止ネジ	1	1
9	2100027	Safety Plate	アイガード	1	1
10-1	2107031	Presser Foot, Complete Set(03)	押エ(組)	1	1
10-2	2107032	" " (04)	"	1	1
11	0024100	Presser Foot Hinge	押エヒンジ	1	1
12	004351	Screw(9/64-40×7)	止ネジ	1	1
13	2107030	Presser Foot(Lower)	押エ(下)	1	1
14-1	2107000	Presser Foot Stitch Tongue(03)	爪	1	1
14-2	2107004	" " (04)	"	1	1
15	2107162	Presser Foot Hinge Spring	押エヒンジバネ	1	1
16	004131	Screw(1/8-44×6)	止ネジ	1	1
17	2100050	Cloth Plate	クロスプレート	1	1
18	2100051	Cloth Plate(Lower)	クロスプレート(下)	1	1
19	2100052	Rubber Cushion	クロスプレート(下)埋メ座	1	1
20-1	2108001	Stitch Plate(03)	針板	1	1
20-2	2108000	" (04)	"	1	1
21	2109000	Differential Feed Dog	前送り	1	1
22	2109001	Main Feed Dog	後送り	1	1
23	2101027	Blind Hemming Guide, C. Set	裾引定規(組)	1	1
24	2101026	Overhanging Guide Hinge, C. Set	定規(組)	1	1
25	0034867	Hemming Positioner	裾引幅調節片	1	1
26	005036	Screw(1/8-44×5.6)	止ネジ	2	2
27	000533	Washer	ワッシャ	1	1
28	007006	Screw(9/64-40×4)	止ネジ	1	1
29	2101021	Blind-Hemming Edge Guide, C. Set	裾引定規台(組)	1	1
30	2101020	Blind-Hemming Edge Guide	裾引定規台	1	1
31	009624	Screw(1/8-44×5.3)	止ネジ	1	1
32	0022445	Swing-out Lever	スイングアウトレバー	1	1
33	004150	Screw(11/64-40×5.2)	止ネジ	1	1
34	000172	Conical Spring Washer	皿バネワッシャ	1	1
35	000334	Nut	ナット	1	1
36	0022446	Overhanging Guide Hinge Stop	定規ストップ	1	1
37	001330	Screw(9/64-40×3.8)	止ネジ	1	1
38	0022447	Swing-out Lever Holder	スイングアウトレバー取付台	1	1
39	0022448	Swing-out Lever Stop	スイングアウトレバーストップ	1	1
40	0022435	Edge Guide Positioning Pin	定規固定ピン	2	2

※ Ref. No. 41 to 50 See the following page.

EXCLUSIVE PARTS for UPPER KNIFE(Angled Type), AZ6000H 角メス及び押エ付部

Ref. No	Parts No	Description	品名	Amt.	Req.
41	0022436	Positioning Pin Holder Spring	定規固定ピン押エバネ	2	2
42	001225	Screw(1/8-44×2.8)	止ネジ	1	1
43	001196	Screw(1/8-44×6)	止ネジ	3	3
44	2101022	Edge Guide Adjusting Holder	裾引調節台	1	1
45	004106	Screw(9/64-40×6.5)	止ネジ	2	2
46	007619	Screw(9/64-40×6.3)	止ネジ	1	1
47	0022443	Adjusting Screw Guide Piece	調節ネジガイド	1	1
48	006444	Adjusting Screw(1/8-44×12.9)	調節ネジ	1	1
49	0022444	Edge Guide Adjusting Holder Cover	裾引調節台蓋	1	1
50	110047	Screw(M4-0.7×10)	止ネジ	2	2

※ Ref. No. 1 to 40 See the preceding page.

※ Ref. No. 51 to 57 See the following page.

AZ6000H-M(2)

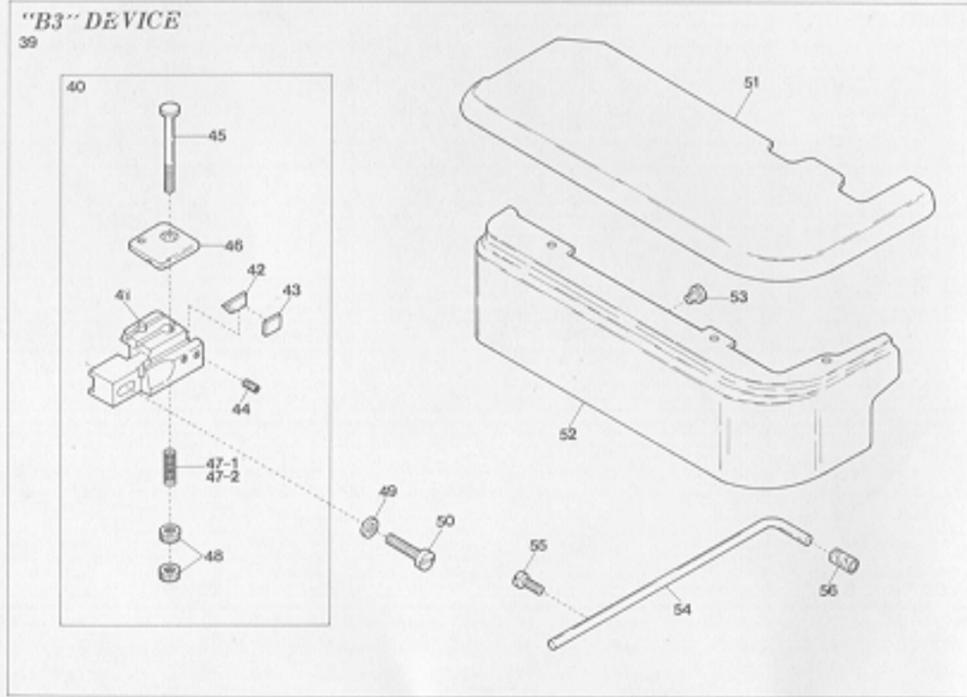
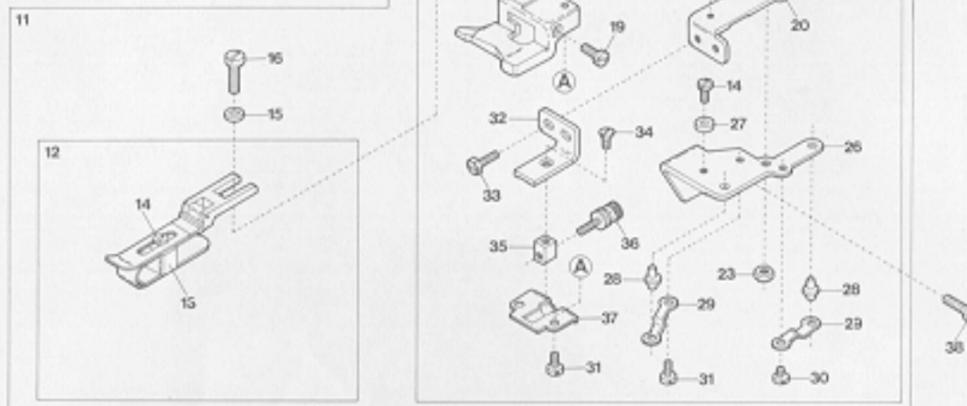
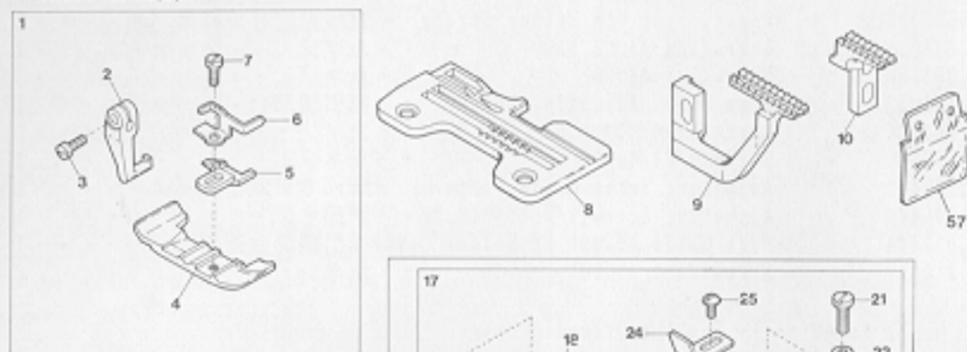

AZ6000H-M EXCLUSIVE PARTS(1)

Ref. No.	Parts No.	Description	品名	Ant. Req.
1	2107032	Presser Foot, Complete Set(04)	押エ(組)	1
2	0024100	Presser Foot Hinge	押エヒンジ	1
3	004351	Screw(9/64-40×7)	止ネジ	1
4	2107030	Presser Foot(Lower)	押エ(下)	1
5	2107004	Presser Foot Stitch Tongue(04)	爪	1
6	2107162	Presser Foot Hinge Spring	押エヒンジバネ	1
7	004131	Screw(1/8-44×6)	止ネジ	1
8	2108032	Stitch Plate(04)	針板	1
9	2109000	Differential Feed Dog	前送り	1
10	2109001	Main Feed Dog	後送り	1
11	2101027	Blind-Hemming Guide, Complete Set	裾引定規(組)	1
12	2101026	Overhanging Guide Hinge, Complete Set	定規(組)	1
13	0034867	Hemming Positioner	裾引幅調節片	1
14	005036	Screw(1/8-44×5.6)	止ネジ	2
15	000533	Washer	ワッシャ	1
16	007006	Screw(9/64-40×4)	止ネジ	1
17	2101021	Blind-Hemming Edge Guide, Complete Set	裾引定規台(組)	1
18	2101020	Blind-Hemming Edge Guide	裾引定規台	1
19	009624	Screw(1/8-44×5.3)	止ネジ	1
20	0022445	Swing-out Lever	スイングアウトレバー	1
21	004150	Screw(11/64-40×5.2)	止ネジ	1
22	000172	Conical Spring Washer	皿バネワッシャ	1
23	000334	Nut	ナット	1
24	0022446	Overhanging Guide Hinge Stop	定規ストッパ	1
25	001330	Screw(9/64-40×3.8)	止ネジ	1
26	0022447	Swing-out Lever Holder	スイングアウトレバーホルダ	1
27	0022448	Swing-out Lever Stop	スイングアウトレバーストッパ	1
28	0022435	Edge Guide Positioning Pin	定規固定ピン	2
29	0022436	Positioning Pin Holder Spring	定規固定ピン押エバネ	2
30	001225	Screw(1/8-44×2.8)	止ネジ	1
31	001196	Screw(1/8-44×6)	止ネジ	3
32	2101022	Edge Guide Adjusting Holder	裾引調節台	1
33	004106	Screw(9/64-40×6.5)	止ネジ	2
34	007619	Screw(9/64-40×6.3)	止ネジ	1
35	0022443	Adjusting Screw Guide Piece	調節ネジガイド	1
36	006444	Adjusting Screw(1/8-44×12.9)	調節ネジ	1
37	0022444	Edge Guide Adjusting Holder Cover	裾引調節台蓋	1
38	110047	Screw(M4-0.7×10)	止ネジ	2
39	2109911	"B3" Device, Complete Set	"B3"装置(組)	1
40	2101133	Back Tuck Cutting Unit	空環切り装置(組)	1

※ Ref. No. 41 to 57 See the following page.

サブモデル専用部品(1) 16

AZ6000H-M EXCLUSIVE PARTS(1)

Ref. No.	Parts No.	Description	品名	Ant. Req.
41	2101134	Chain-off Cutting Knife Holder	刃取付台	1
42	0023184	Chain-off Cutting Knife	刃	1
43	0023169	Chain-off Cutting Knife Holder Spacer	刃取付台スペーサ	1
44	003637	Screw(1/8-44×2.5)	止ネジ	2
45	004205	Screw(11/64-40×18)	止ネジ	1
46	0024308	Chain-off Holder	空環押エ	1
47-1	0023182	Chain-off Holder Spring(Standard)	空環押エバネ(標準)	1
47-2	0033711	" (with Stronger Pressure)	空環押エバネ(強い)	1
48	000361	Adjusting Nut	空環押エバネ調節ナット	2
49	000535	Washer	ワッシャ	1
50	110044	Screw(M3.5-0.6×14)	止ネジ	1
51	2101043	Cloth Plate	クロスプレート	1
52	2100051	Cloth Plate(Lower)	クロスプレート(下)	1
53	2100052	Rubber Cushion	クロスプレート(下)埋メ座	1
54	0036905	Synchronizer Positioning Pin	ボジショナピン	1
55	110009	Screw(M4-0.7×8)	止ネジ	1
56	0022837	Synchronizer Cushion	ボジショナピンクッション	1
57	2100027	Safety Plate	アイガード	1

※ Ref. No. 1 to 40 See the preceding page.



AZ6000H-M(2)

"TC" DEVICE

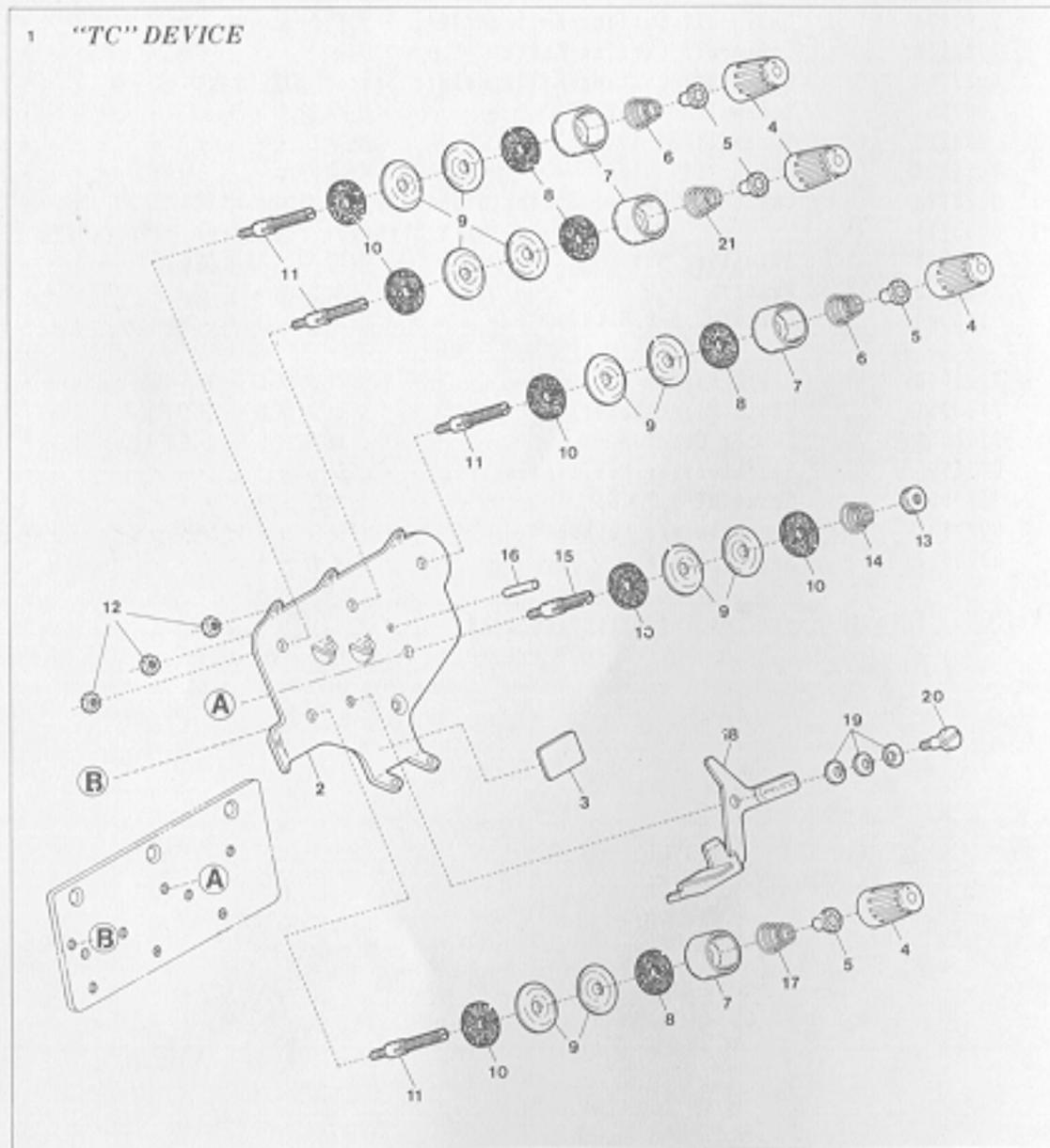

"MS" DEVICE

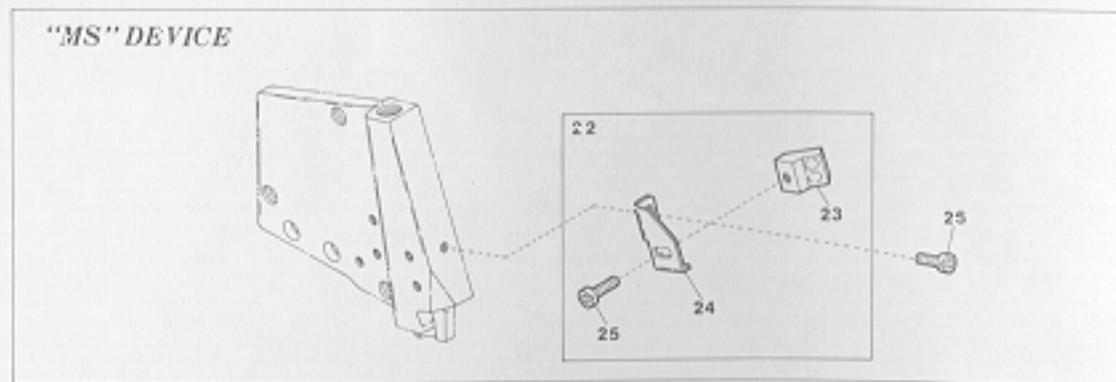

AZ6000H-M EXCLUSIVE PARTS(2)

サブモデル専用部品(2)

Ref. No.	Parts No.	Description	品名	Amt.	Req.
1	0026467	Tension Change Device, C. Set	"TC"装置(組)	1	1
2	0026466	Thread Tension Disc Eyelet	調子台糸道	1	1
3	000622	Sticker	貼リマーク	1	1
4	0024084	Thread Tension Spring Cap	糸調子バネキャップ(上)	4	4
5	0024083	Thread Tension Spring Bushing	糸調子ナット回り止メ	4	4
6	0024157	Thread Tension Spring	糸調子バネ	2	2
7	0020118	Thread Tension Spring Retainer	糸調子バネキャップ(下)	4	4
8	000178	Felt	フェルト	4	4
9	0031111	Tension Disc	糸調子皿	10	10
10	000177	Felt	フェルト	6	6
11	007903	Tension Post	糸調子棒	4	4
12	000334	Nut	ナット	3	3
13	000056	Adjusting Nut	調節ナット	1	1
14	0037114	Thread Tension Spring	糸調子バネ	1	1
15	001904	Tension Post	糸調子棒	1	1
16	0023766	Thread Guide Pin	糸ガイドピン	1	1
17	0024156	Thread Tension Spring	糸調子バネ	1	1
18	0023728	Tension Change Lever	TCレバー	1	1
19	000010	Conical Spring Washer	皿バネワッシャ	3	3
20	004100	Screw(11/64-40×3.2)	止ネジ	1	1
21	0032952	Thread Tension Spring	糸調子バネ	1	1
22	2101182	"MS" Device, Complete Set	"MS"装置(組)	1	1
23	2100079	Magnet Unit	マグネット	1	1
24	2100076	Magnet Unit Support	マグネット受ケ	1	1
25	110012	Screw(M4-0.7×5)	止ネジ	1	1
26	110013	Screw(M4-0.7×8)	止ネジ	1	1
27	0012466	Offsetting Guide Stop	定規ストッパ	1	1
28	001230	Screw(M4-0.7×4)	止ネジ	1	1
29	0023447	Spring-out Lever Holder	スプリングアウトレバー取付台	1	1
30	0023448	Spring-out Lever Stop	M4/7/10/12	1	1
31	0023453	Edge Guide Adjusting Pin	辺取調整ピン	1	1
32	0023426	Positioning Pin Holder Spring	定規調整ピン	2	2
33	001225	Screw(11/64-40×2)	止ネジ	1	1
34	001396	Screw(11/64-40×3)	止ネジ	1	1
35	2101071	Edge Guide Adjusting Holder	辺取調整台	1	1
36	004126	Screw(11/64-40×6.5)	止ネジ	1	1
37	007819	Screw(11/64-40×6.3)	止ネジ	1	1
38	0022443	Adjusting Screw Guide Piece	調節ネジガイド	1	1
39	006444	Adjusting Screw(1/8-44×12.9)	調節ネジ	1	1
40	0022444	Edge Guide Adjusting Holder Cover	辺取調整台蓋	1	1
41	110047	Screw(M4-0.7×10)	止ネジ	1	1
42	2104052	Auxiliary Feed Dog	小送り	1	1
43	2104077	Safety Plate	アイガード	1	1

AZ6000H-54

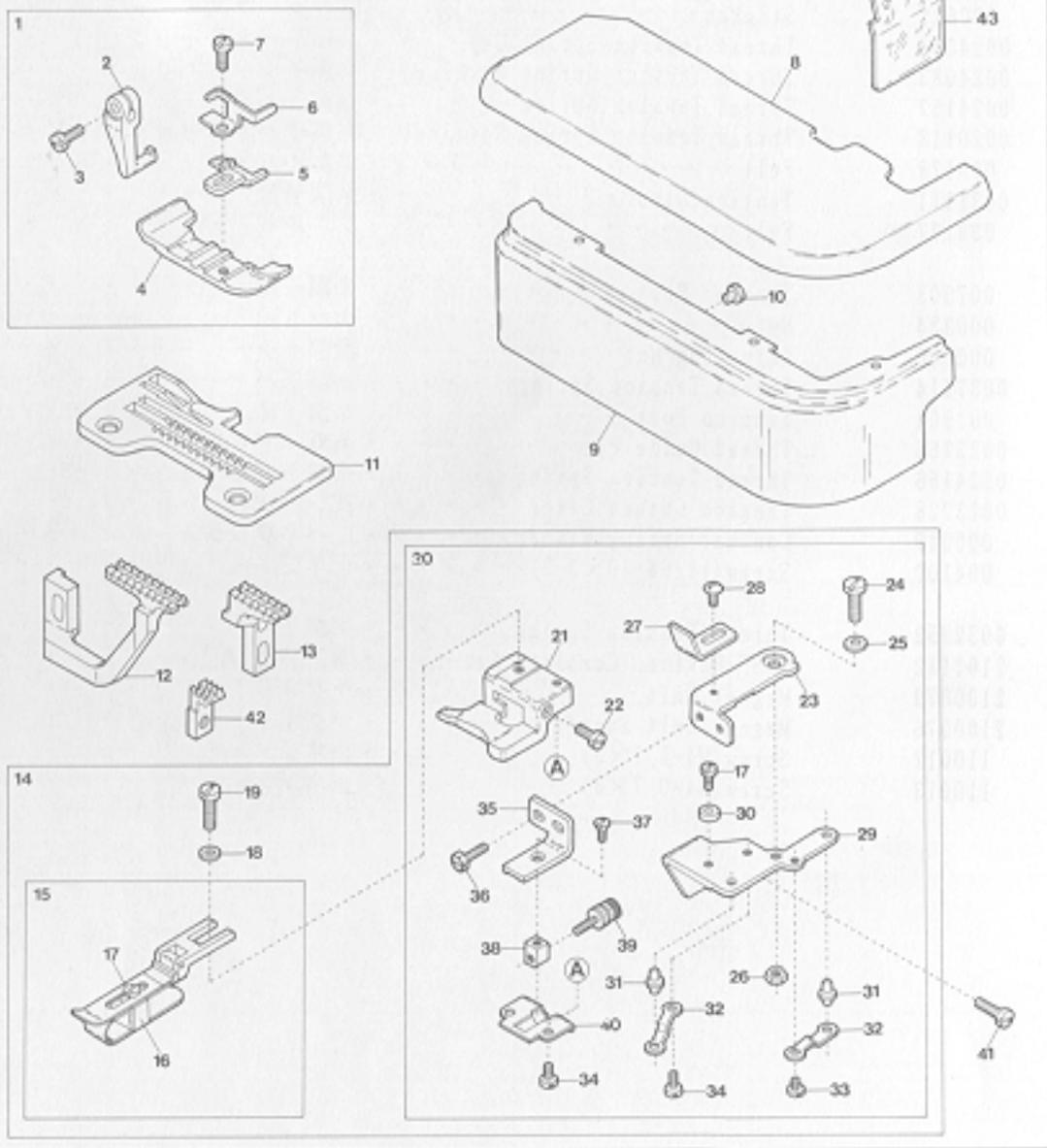

AZ6000H-54 EXCLUSIVE PARTS

Ref. No.	Parts No.	Description	品名	Ant. Req.
1	2107032	Presser Foot, Complete Set(04)	押エ(組)	1
2	0024100	Presser Foot Hinge	押エヒンジ	1
3	004351	Screw(9/64-40×7)	止ネジ	1
4	2107030	Presser Foot(Lower)	押エ(下)	1
5	2107004	Presser Foot Stitch Tongue(04)	爪	1
6	2107162	Presser Foot Hinge Spring	押エヒンジバネ	1
7	004131	Screw(1/8-44×6)	止ネジ	1
8	2100050	Cloth Plate	クロスプレート	1
9	2100051	Cloth Plate(Lower)	クロスプレート(下)	1
10	2100052	Rubber Cushion	クロスプレート(下)埋メ座	1
11	2108100	Stitch Plate(04)	針板	1
12	2109000	Differential Feed Dog	前送り	1
13	2109001	Main Feed Dog	後送り	1
14	2101027	Blind Hemming Guide, Complete Set	裾引定規(組)	1
15	2101026	Overhanging Guide Hinge, Complete Set	定規(組)	1
16	0034867	Hemming Positioner	裾引幅調節片	1
17	005036	Screw(1/8-44×5.6)	止ネジ	2
18	000533	Washer	ワッシャ	1
19	007006	Screw(9/64-40×4)	止ネジ	1
20	2101021	Blind-Hemming Edge Guide, Complete Set	裾引定規台(組)	1
21	2101020	Blind-Hemming Edge Guide	裾引定規台	1
22	009624	Screw(1/8-44×5.3)	止ネジ	1
23	0022445	Swing-out Lever	スイングアウトレバー	1
24	004150	Screw(11/64-40×5.2)	止ネジ	1
25	000172	Conical Spring Washer	皿バネワッシャ	1
26	000334	Nut	ナット	1
27	0022446	Overhanging Guide Hing Stop	定規ストッパ	1
28	001330	Screw(9/64-40×3.8)	止ネジ	1
29	0022447	Swing-out Lever Holder	スイングアウトレバー取付台	1
30	0022448	Swing-out Lever Stop	スイングアウトレバーストップ	1
31	0022435	Edge Guide Positioning Pin	定規固定ピン	2
32	0022436	Positioning Pin Holder Spring	定規固定ピン押エバネ	2
33	001225	Screw(1/8-44×2.8)	止ネジ	1
34	001196	Screw(1/8-44×6)	止ネジ	3
35	2101022	Edge Guide Adjusting Holder	裾引調節台	1
36	004106	Screw(9/64-40×6.5)	止ネジ	2
37	007619	Screw(9/64-40×6.3)	止ネジ	1
38	0022443	Adjusting Screw Guide Piece	調節ネジガイド	1
39	006444	Adjusting Screw(1/8-44×12.9)	調節ネジ	1
40	0022444	Edge Guide Adjusting Holder Cover	裾引調節台蓋	1
41	110047	Screw(M4-0.7×10)	止ネジ	2
42	2109052	Auxiliary Feed Dog	小送り	1
43	2100027	Safety Plate	アイガード	1

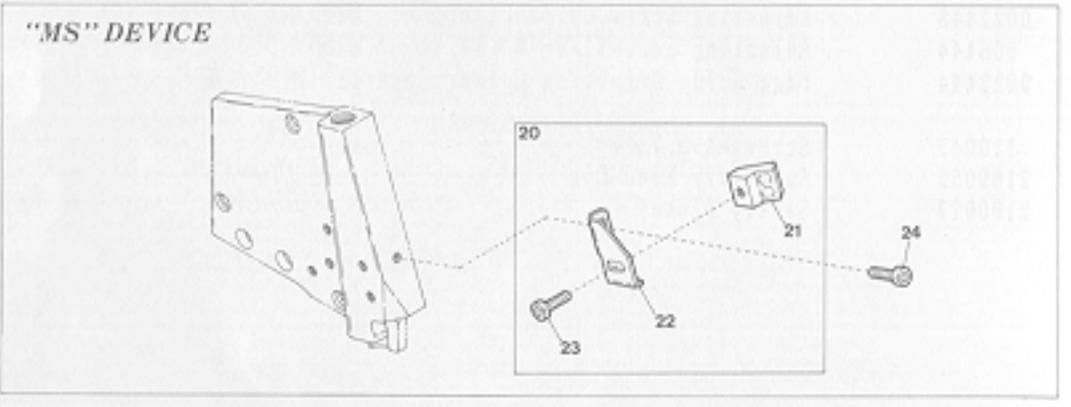
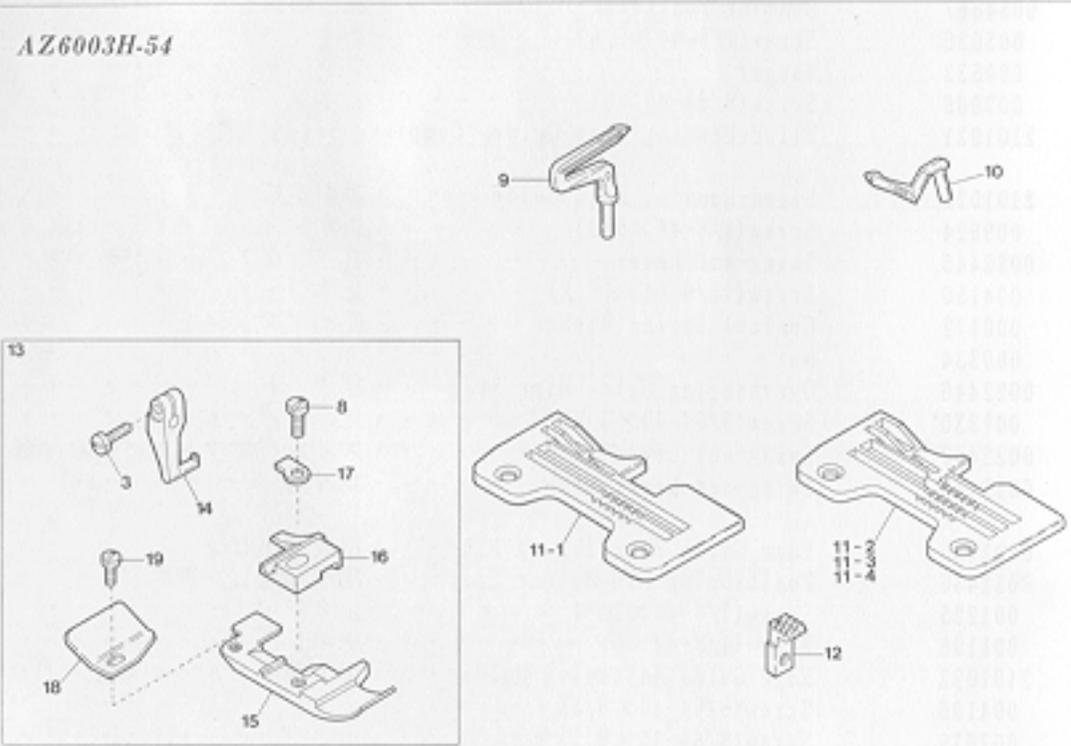
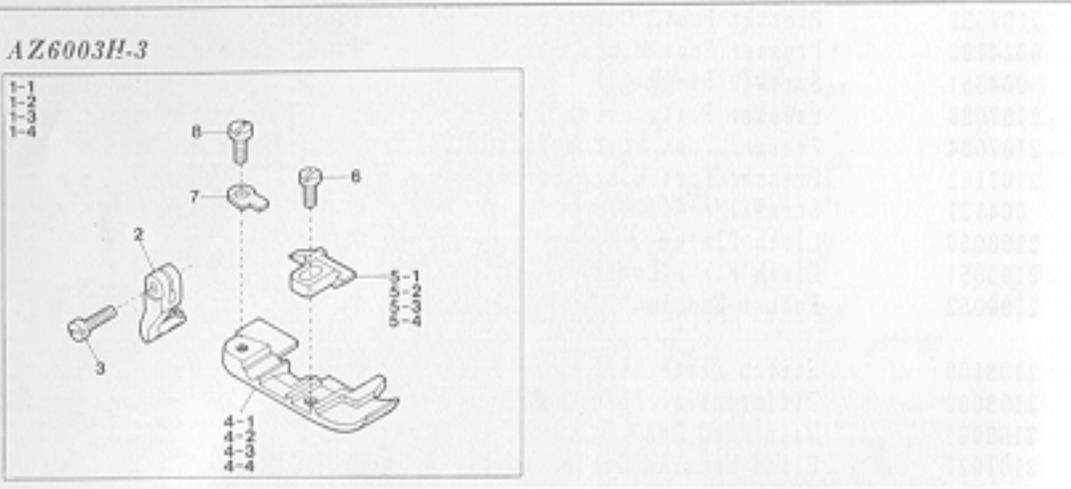

AZ6003H-3, 6003H-54 EXCLUSIVE PARTS

サブモデル専用部品

Ref. No.	Parts No.	Description	品名	Amt. Req.
1-1	2107350	Presser Foot, Complete Set(03)	押エ(組)	1
1-2	2107351	"	"	1
1-3	2107352	"	"	1
1-4	2107353	"	"	1
2	0024420	Presser Foot Hinge	押エヒンジ	1
3	004351	Screw(9/64-40×7)	止ネジ	1
4-1	2107036	Presser Foot(Lower)(03)	押エ(下)	1
4-2	0024422	"	"	1
4-3	2107037	"	"	1
4-4	0024425	"	"	1
5-1	2107006	Presser Foot Stitch Tongue(03)	爪	1
5-2	2107008	"	"	1
5-3	2107009	"	"	1
5-4	2107020	"	"	1
6	009730	Screw(1/8-44×5.3)	止ネジ	1
7	0024421	Presser Foot Hinge Spring	押エヒンジバネ	1
8	005036	Screw(1/8-44×5.6)	止ネジ	1
9	2109331	Lower Loper(for Thick Thread)	下ルーパー(太糸用)	1
10	2109324	Upper Loper(for Thick Thread)(#9~14)	上ルーパー(太糸用)(#9~14)	1
11-1	2108024	Stitch Plate(03)(Extra)	針板(特注品)	1
11-2	2108010	"	"	1
11-3	2108026	"	"	1
11-4	2108027	"	"	1
12	2109052	Auxiliary Feed Dog	小送り	1
13	2107346	Presser Foot, Complete Set(04)	押エ(組)	1
14	0024100	Presser Foot Hinge	押エヒンジ	1
15	2107286	Presser Foot(Lower)	押エ(下)	1
16	2107243	Presser Foot Stitch Tongue(04)	爪	1
17	0021005	Presser Foot Hinge Spring	押エヒンジバネ	1
18	0034535	Presser Foot Chain Shield	空糸押エ	1
19	004237	Screw(3/32-56×2.6)	止ネジ	1
20	2101182	"MS" Device, Complete Set	"MS"装置(組)	1
21	2100079	Magnet Unit	マグネット	1
22	2100076	Magnet Unit Support	マグネット受ケ	1
23	110012	Screw(M4-0.7×5)	止ネジ	1
24	110013	Screw(M4-0.7×8)	止ネジ	1

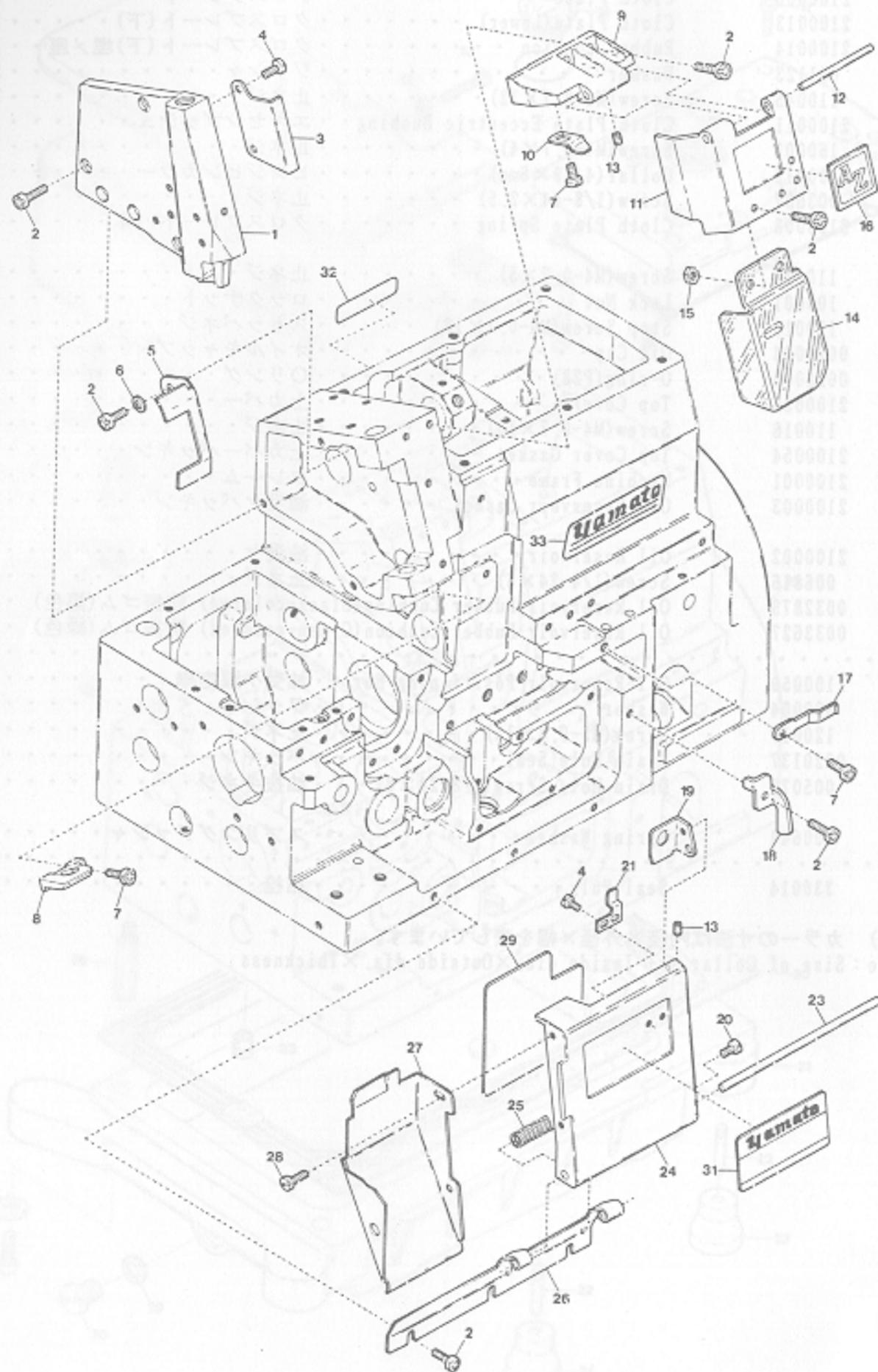

MISCELLANEOUS COVERS(2)

カバー関係(2)

Ref. No.	Parts No.	Description	品名	Amt.	Req.
1	2100028	Side Cover	側面カバー	1	1
2	110013	Screw(M4-0.7×8)	止ネジ	12	12
3	2100049	Needle Bar Cover(Left)	針棒カバー(左)	1	1
4	110054	Screw(M3-0.5×3.5)	止ネジ	4	4
5	2100048	Needle Bar Cover(Rear)	針棒カバー(後)	1	1
6	000538	Washer	ワッシャ	1	1
7	110012	Screw(M4-0.7×5)	止ネジ	3	3
8	2100143	Needle Bar Oil Defender	針棒油受ケ	1	1
9	2100018	Needle Thread Cover Hinge	針糸カバーヒンジ	1	1
10	2100019	Needle Thread Cover Hinge Spring	針糸カバーヒンジバネ	1	1
11	2100017	Needle Thread Cover	針糸カバー	1	1
12	2100020	Needle Thread Cover Hinge Pin	針糸カバーヒンジピン	1	1
13	003637	Screw(1/8-44×2.5)	止ネジ	3	3
14	2100081	Safety Plate	アイガード	1	1
15	100001	Nut	ナット	2	2
16	390010	"AZ" Mark	AZマーク	1	1
17	2100538	Front Cover Latch Spring	前開キカバーラッチバネ	1	1
18	2100022	Front Cover Hook Guide	前開キカバー案内	1	1
19	0024446	Front Cover Hook	前開キカバーフック	1	1
20	001330	Screw(9/64-40×3.8)	止ネジ	1	1
21	0024085	Front Cover Latch	前開キカバーラッチ	1	1
22					
23	0020016	Front Cover Hinge Pin	前開キカバーヒンジピン	1	1
24	2100024	Front Cover(Right)	前開キカバー	1	1
25	0024095	Front Cover Hinge Spring	前開キカバーヒンジバネ	1	1
26	2100025	Front Cover Hinge	前開キカバーヒンジ	1	1
27	2100534	Chip Guard(Openable)	切屑落シ板	1	1
28	110003	Screw(M3.5-0.6×6)	止ネジ	2	2
29		Threading Chart(See the Table)	糸通シ図(下表参照)	1	1
30					
31	2129420	Model Plate	型式板	1	1
32	390070	Brand Name Plsate(Small)	銘板(小)	1	1
33	390068	Brand Name Plsate(Large)	銘板(大)	1	1

Models	Parts No. Threading Chart	Models	Parts No. Threading Chart
AZ6000H	390575	AZ6045H	390575
AZ6000H-M	390583	AZ6046H	390576
AZ6003H	390575	AZ6051H	390586
AZ6015H	"	AZ6098H	390576
AZ6016H	"	AZ6000H/TC	390583
AZ6017H	"	AZ6003H/KR2	390579
AZ6020H	390576	AZ6003H/MU5	"
AZ6021H	"	AZ6003H/BT13	"
AZ6025H	"	AZ6020H/KR2	390580
AZ6032H	"	AZ6020H/MU5	"
AZ6035H	"	AZ6020H/BT13	"
		AZ6020H/UC	390573

(注) 型式板を御注文の際は機種名(ゲージ記号, 付帯装置含む)をお知らせ下さい。
 Note: Order for Model Plate must be accompanied by model designation(including symbols of gauge and devices).

AZ6063H-61

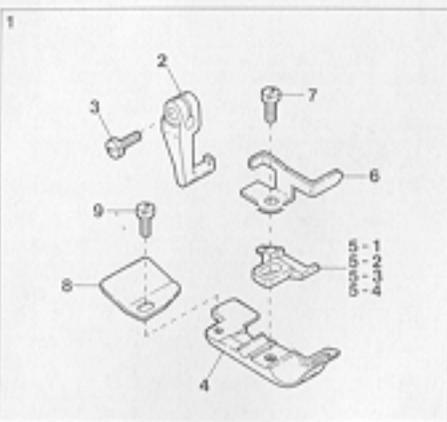

EXTRA PARTS for Curled down edge seam

下巻縫用

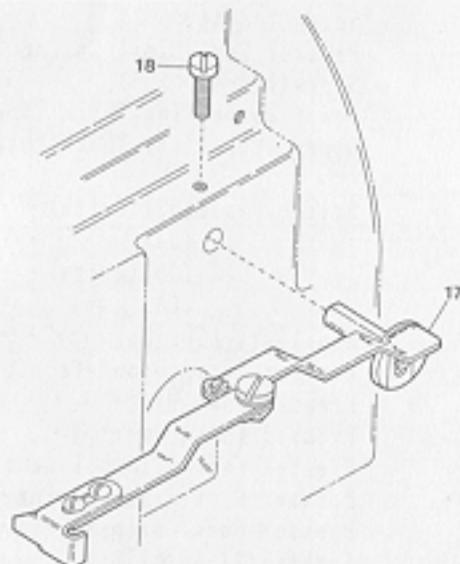
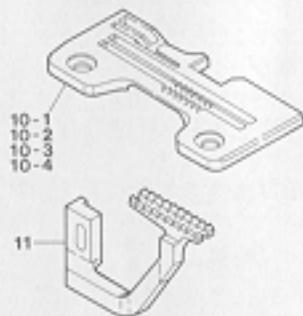
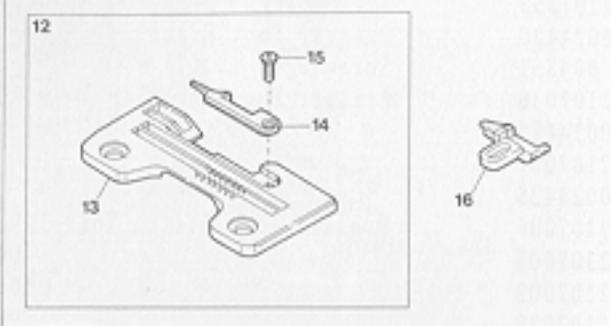

AZ6003H-61 EXCLUSIVE PARTS

サブモデル専用部品

Ref. No.	Parts No.	Description	品名	Amt.	Req.
1	2107393	Presser Foot, Complete Set(05)	押エ(組)	1	1
2	0024100	Presser Foot Hinge	押エヒンジ	1	1
3	004351	Screw(9/64-40×7)	止ネジ	1	1
4	2107291	Presser Foot(Lower)	押エ(下)	1	1
5-1	2107254	Presser Foot Stitch Tongue(05)	爪	1	1
5-2	2107000	Presser Foot Stitch Tongue(03)	(03)(Extra)爪(特注品)	1	1
5-3	2107253	Presser Foot Stitch Tongue(04)	(04)(Extra)爪	1	1
5-4	2107255	Presser Foot Stitch Tongue(06)	(06)(Extra)爪	1	1
6	2107162	Presser Foot Hinge Spring	押エヒンジバネ	1	1
7	005036	Screw(1/8-44×5.6)	止ネジ	1	1
8	0034535	Presser Foot Chain Shield	空糸押エ	1	1
9	004237	Screw(3/32-56×2.6)	止ネジ	1	1
10-1	2108112	Stitch Plate(05)	針板	1	1
10-2	2108110	Stitch Plate(03)	(03)(Extra)針板(特注品)	1	1
10-3	2108111	Stitch Plate(04)	(04)(Extra)針板	1	1
10-4	2108113	Stitch Plate(06)	(06)(Extra)針板	1	1
11	2109007	Differential Feed Dog(for 03)	前送り(03用)	1	1
12	2108116	Stitch Plate, C. Set	針板(組)	1	1
13	2108114	Stitch Plate	針板	1	1
14	2108115	Stitch Plate Tongue	針板爪	1	1
15	4182	Screw(3/32-56×2.5)	止ネジ	1	1
16	2107256	Presser Foot Stitch Tongue	爪	1	1
17	0020700	Edge Guide, Complete Set	当て定規(組)	1	1
18	110009	Screw(M4-0.7×8)	止ネジ	1	1



AZ6015H-57/B3/K2
AZ6017H-57/B3/K2

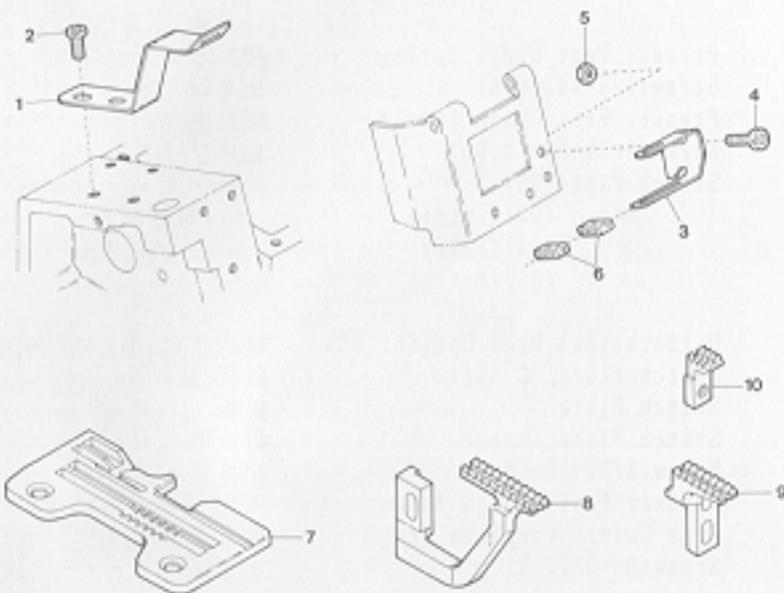

AZ6015H-57/B3/K2

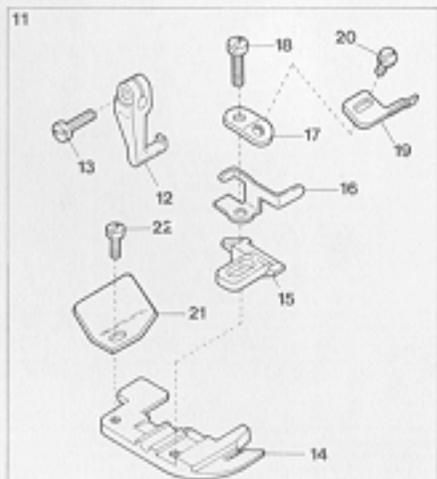

AZ6017H-57/B3/K2

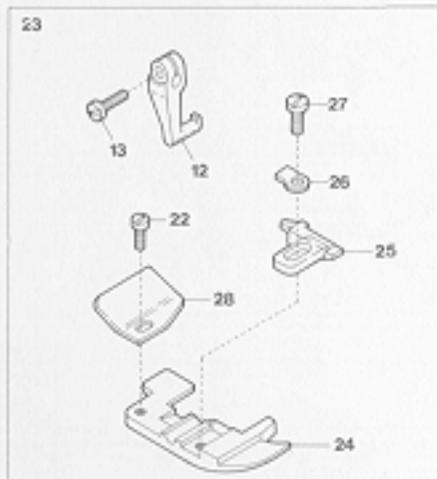

AZ6015H-57, 6017H-57 EXCLUSIVE PARTS

サブモデル専用部品

21

Ref. No.	Parts No.	Description	品名	Amt. Req.
1	0024130	Tape Guide(Upper)	テープガイド(上)	1
2	110012	Screw(M4-0.7×5)	止ネジ	2
3	0024129	Tape Guide(Lower)	テープガイド(下)	1
4	110013	Screw(M4-0.7×8)	止ネジ	2
5	100001	Nut	ナット	2
6	0033738	Tape Guide Tube	テープ支エ	2
7	2108009	Stitch Plate(04)	針板	1
8	2109010	Differential Feed Dog	前送り	1
9	2109011	Main Feed Dog	後送り	1
10	2109052	Auxiliary Feed Dog	小送り	1
11	2107370	Presser Foot, Complete Set(04)	押エ(組)	1
12	0024100	Presser Foot Hinge	押エヒンジ	1
13	004351	Screw(9/64-40×7)	止ネジ	1
14	2107290	Presser Foot(Lower)	押エ(下)	1
15	2107226	Presser Foot Stitch Tongue(04)	爪	1
16	2107162	Presser Foot Hinge Spring	押エヒンジバネ	1
17	2107173	Tape Guide Support	テープガイド取付板	1
18	210005	Screw(1/8-44×7.1)	止ネジ	1
19	2107174	Presser Foot Tape Guide	押エテープガイド	1
20	001228	Screw(3/32-56×3.2)	止ネジ	1
21	2107219	Presser Foot Chain Shield	空糸押エ	1
22	004237	Screw(3/32-56×2.6)	止ネジ	1
23	2107063	Presser Foot, Complete Set(04)	押エ(組)	1
24	2107045	Presser Foot(Lower)	押エ(下)	1
25	2107046	Presser Foot Stitch Tongue(04)	爪	1
26	0021005	Presser Foot Hinge Spring	押エヒンジバネ	1
27	005036	Screw(1/8-44×5.6)	止ネジ	1
28	0034535	Presser Foot Chain Shield	空糸押エ	1

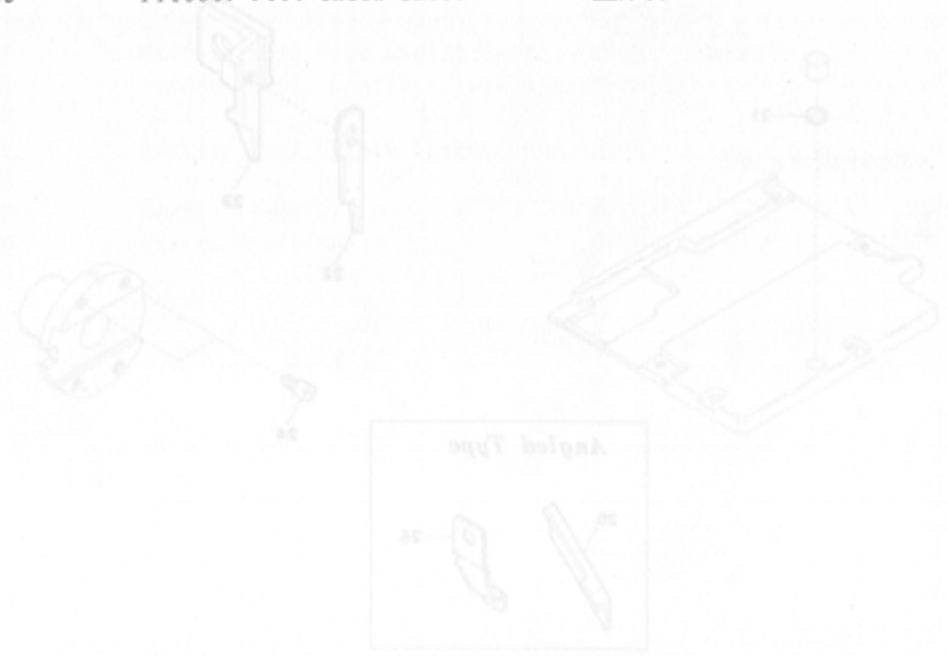

AZ6016H

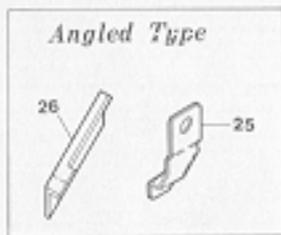
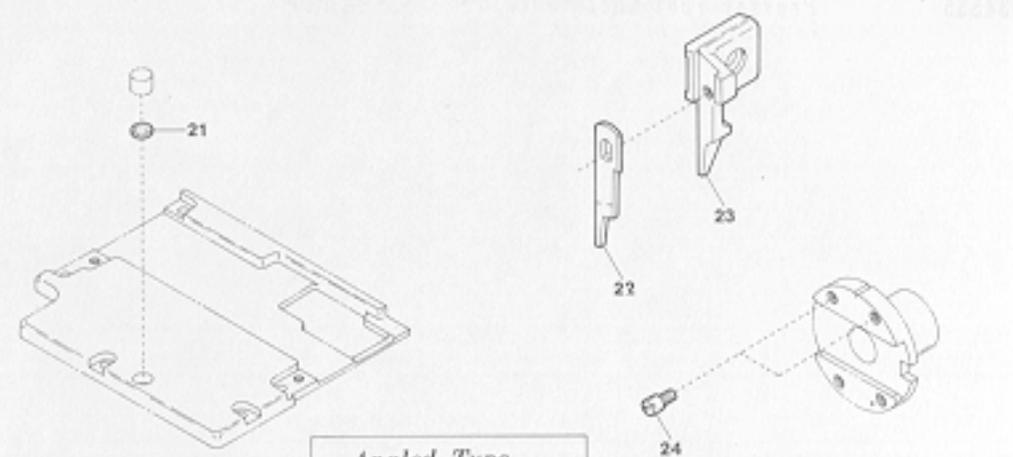
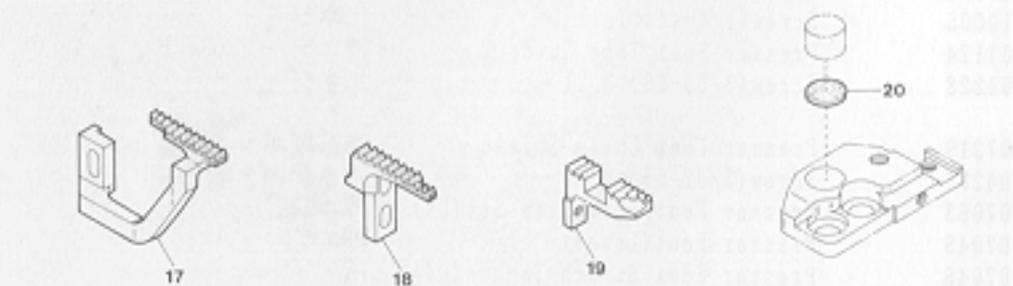
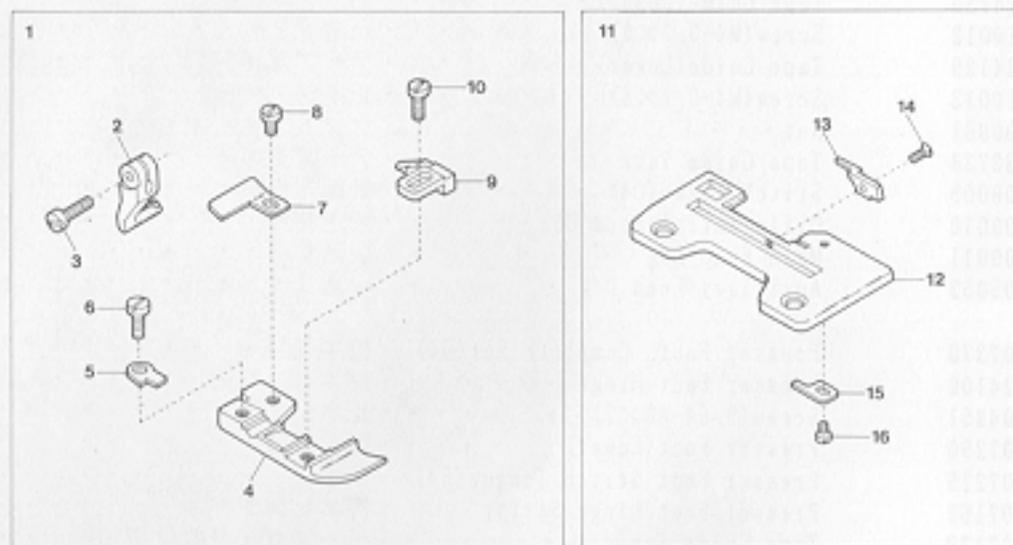

AZ6016H EXCLUSIVE PARTS

Ref. No.	Parts No.	Description	品名	Ant. Req.
1	2107084	Presser Foot, Complete Set(02)	押エ(組)	1
2	2107085	Presser Foot Hinge	押エヒンジ	1
3	004351	Screw(9/64-40×7)	止ネジ	1
4	0024505	Presser Foot(Lower)	押エ(下)	1
5	0024421	Presser Foot Hinge Spring	押エヒンジバネ	1
6	004131	Screw(1/8-44×6)	止ネジ	1
7	0022156	Presser Foot Chain Shield	空糸押エ	1
8	004237	Screw(3/32-56×2.6)	止ネジ	1
9	0024506	Presser Foot Stitch Tongue	爪	1
10	004138	Screw(1/8-44×5)	止ネジ	1
11	2108016	Stitch Plate, Complete Set	針板(組)	1
12	2108017	Stitch Plate	針板	1
13	2108015	Stitch Plate Tongue	針板爪	1
14	004204	Screw(3/32-100×2.2)	止ネジ	1
15	0024503	Stitch Plate Tongue Stop	針板爪ストッパ	1
16	001228	Screw(3/32-56×3.2)	止ネジ	1
17	2109017	Differential Feed Dog(with Rubber Face)	前送り(ゴム送り)	1
18	2109018	Main Feed Dog(with Rubber Face)	後送り(ゴム送り)	1
19	2109019	Auxiliary Feed Dog	小送り	1
20	000932	Rubber Cushion(Large)	埋メ座(大)	1
21	000933	Rubber Cushion(Medium)	埋メ座(中)	1
22	0023580	Upper Knife	上メス	1
23	2100346	Upper Knife Holder	上メスホルダ	1
24	180002	Screw(M3-0.5×4)	止ネジ	2
25	2100347	Upper Knife Chip Guard(Angled Type)	切屑押シ(角メス用)	1
26	2020003	Upper Knife(Angled Type)	上メス(角メス用)	1

AZ6020H-Y, X

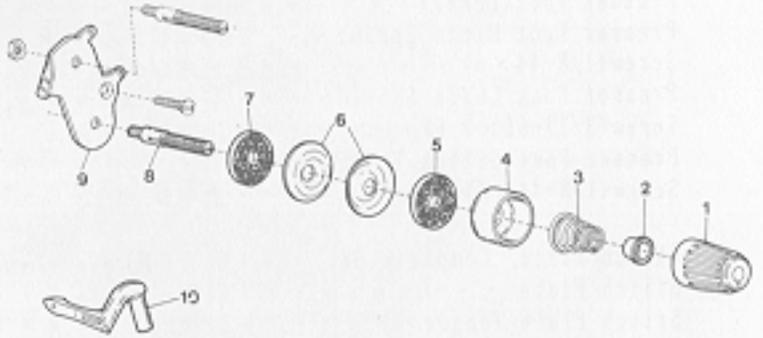

AZ6020H-Y4, Y5, Y6

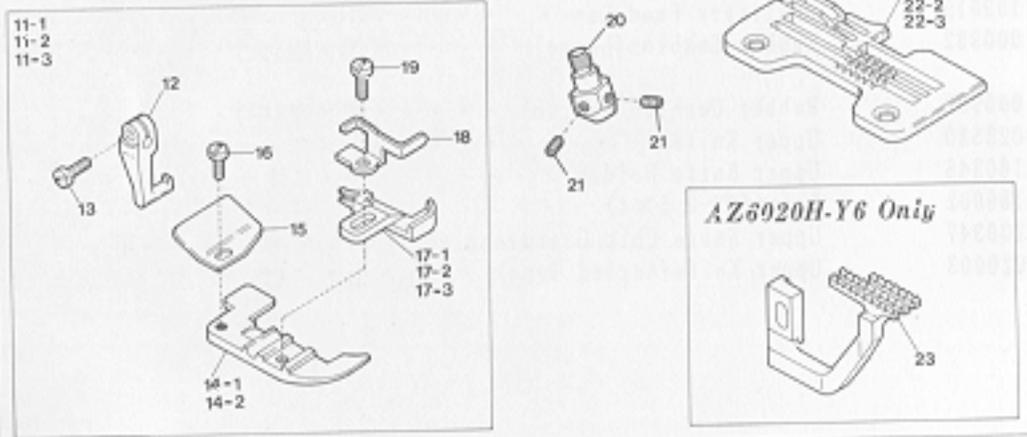

AZ6020H-X4, X5

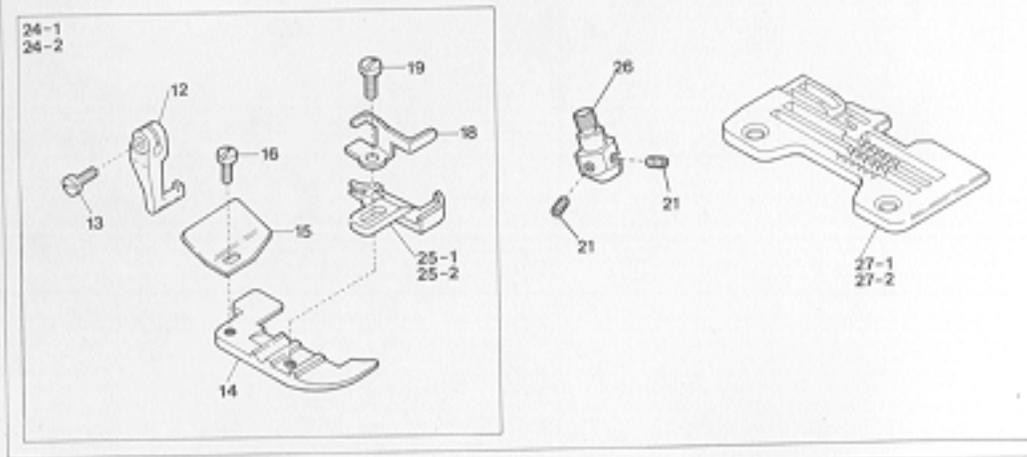

AZ6020H-Y, X EXCLUSIVE PARTS

Ref. No.	Parts No.	Description	品名	Amt. Req.
1	0024084	Thread Tension Spring Cap	糸調子バネキャップ(上)	1
2	0024083	Tension Spring Bushing	糸調子ナット回り止メ	1
3	0032971	Needle Thread Tension Spring	針糸調子バネ	1
4	0030118	Thread Tension Spring Retainer	糸調子バネキャップ(下)	1
5	000178	Felt	フェルト	1
6	0031111	Tension Disc	糸調子皿	2
7	000177	Felt	フェルト	1
8	004265	Tension Post(Short)	糸調子棒(短)	1
9	2100074	Tension Disc Eyelet(Large)	調子台糸道(大)	1
10	2109322	Upper Looper(for Needle Size #9~14)	上ルーパ(針番手#9~14用)	1
11-1	2117012	Presser Foot, Complete Set(Y4)	押エ(組)	1
11-2	2107310	" " (Y5)	"	1
11-3	2107311	" " (Y6)	"	1
12	0024100	Presser Foot Hinge	押エヒンジ	1
13	004351	Screw(9/64-40×7)	止ネジ	1
14-1	2117000	Presser Foot(Lower)(Y4)	押エ(下)	1
14-2	2107280	" " (Y5, Y6)	"	1
15	0034535	Presser Foot Chain Shield	空糸押エ	1
16	004237	Screw(3/32-56×2.6)	止ネジ	1
17-1	2117011	Presser Foot Stitch Tongue(Y4)	爪	1
17-2	2107230	" " (Y5)	"	1
17-3	2107231	" " (Y6)	"	1
18	2107162	Presser Foot Hinge Spring	押エヒンジバネ	1
19	005036	Screw(1/8-44×5.6)	止ネジ	1
20	2109130	Needle Clamp(Y)	針止メ	1
21	003637	Screw(1/8-44×2.5)	止ネジ	2
22-1	2108120	Stitch Plate(Y4)	針板	1
22-2	2108004	" (Y5)	"	1
22-3	2108005	" (Y6)	"	1
23	2109009	Differential Feed Dog(Y6 Only)	前送り(Y6のみ)	1
24-1	2107312	Presser Foot, Complete Set(X4)	押エ(組)	1
24-2	2107313	" " (X5)	"	1
25-1	2107232	Presser Foot Stitch Tongue(X4)	爪	1
25-2	2107233	" " (X5)	"	1
26	2109131	Needle Clamp(X)	針止メ	1
27-1	2108006	Stitch Plate(X4)	針板	1
27-2	2108014	" (X5)	"	1



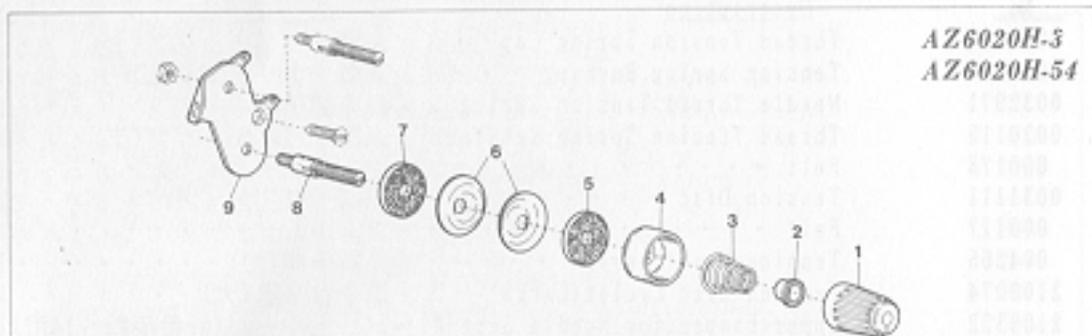

AZ6020H-3
AZ6020H-54

AZ6020H-Y-3

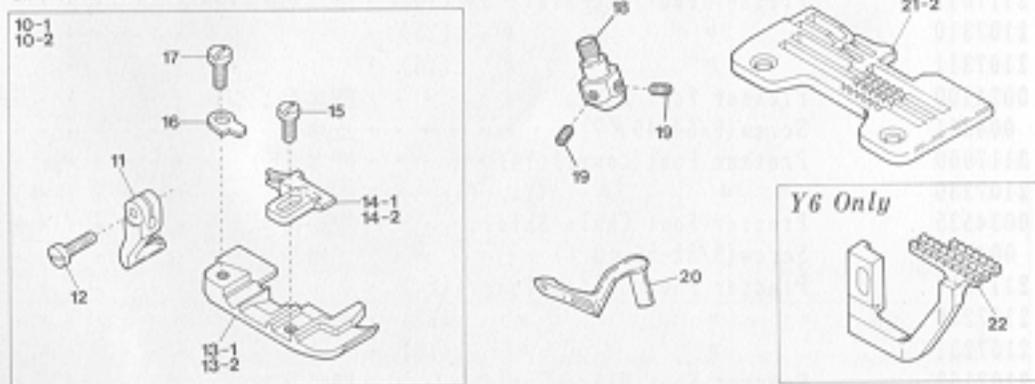

AZ6020H-X-3

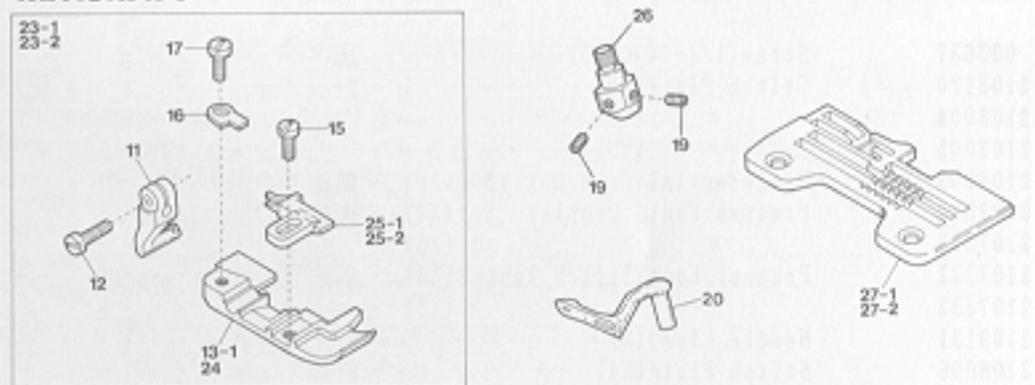

AZ6020H-Y-54

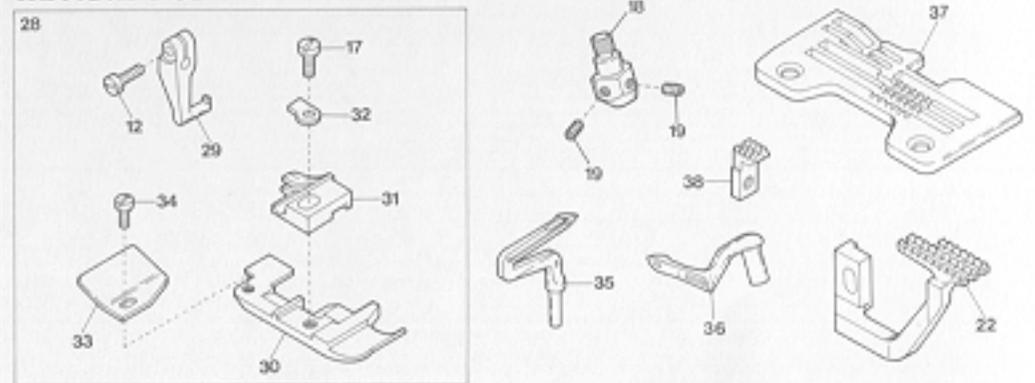

Ref. No.	Parts No.	Description	品名	Amt. Req.
1	0024084	Thread Tension Spring Cap	糸調子バネキャップ(上)	1
2	0024083	Tension Spring Bushing	糸調子ナット回り止メ	1
3	0032971	Needle Thread Tension Spring	針糸調子バネ	1
4	0020118	Thread Tension Spring Retainer	糸調子バネキャップ(下)	1
5	000178	Felt	フェルト	1
6	0031111	Tension Disc	糸調子皿	2
7	000177	Felt	フェルト	1
8	004265	Tension Post (Short)	糸調子棒(短)	1
9	2100074	Tension Disc Eyelet (Large)	調子台糸道(大)	1
10-1	2107356	Presser Foot, Complete Set (Y5)	押エ(組)	1
10-2	2107357	" " (Y6)	"	1
11	0024420	Presser Foot Hinge	押エヒンジ	1
12	004351	Screw (9/64-40×7)	止ネジ	1
13-1	2107037	Presser Foot (Lower) (Y5, X5)	押エ(下)	1
13-2	0024425	" " (Y6)	"	1
14-1	2107011	Presser Foot Stitch Tongue (Y5)	爪	1
14-2	2107019	" " (Y6)	"	1
15	009730	Screw (1/8-44×5, 3)	止ネジ	1
16	0024421	Presser Foot Hinge Spring	押エヒンジバネ	1
17	005036	Screw (1/8-44×5, 6)	止ネジ	1
18	2109130	Needle Clamp (Y)	針止メ	1
19	003637	Screw (1/8-44×2, 5)	止ネジ	2
20	2109322	Upper Loper (for Needle Size #9~14)	上ルーバ(針番手 #9~14用)	1
21-1	2108004	Stitch Plate (Y5)	針板	1
21-2	2108005	" (Y6)	"	1
22	2109009	Differential Feed Dog (Y6 Only)	前送り (Y6のみ)	1
23-1	2107354	Presser Foot, Complete Set (X4)	押エ(組)	1
23-2	2107355	" " (X5)	"	1
24	0024422	Presser Foot (Lower) (X4)	押エ(下)	1
25-1	2107017	Presser Foot Stitch Tongue (X4)	爪	1
25-2	2107023	" " (X5)	"	1
26	2109131	Needle Clamp (X)	針止メ	1
27-1	2108006	Stitch Plate (X4)	針板	1
27-2	2108014	" (X5)	"	1
28	2107044	Presser Foot, Complete Set (Y6)	押エ(組)	1
29	0024100	Presser Foot Hinge	押エヒンジ	1
30	2107039	Presser Foot (Lower)	押エ(下)	1
31	2107042	Presser Foot Stitch Tongue (Y6)	爪	1
32	0021005	Presser Foot Hinge Spring	押エヒンジバネ	1
33	0034535	Presser Foot Chain Shield	空糸押エ	1
34	004237	Screw (3/32-56×2, 6)	止ネジ	1
35	2109331	Lower Loper (for Thick Thread)	下ルーバ(太糸用)	1
36	2109326	Upper Loper (for Thick Thread) (#9~14)	上ルーバ(太糸用) (#9~14)	1
37	2108021	Stitch Plate (Y6)	針板	1
38	2109052	Auxiliary Feed Dog	小送り	1

AZ6021H-A

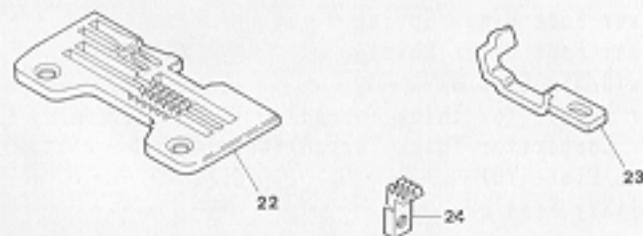
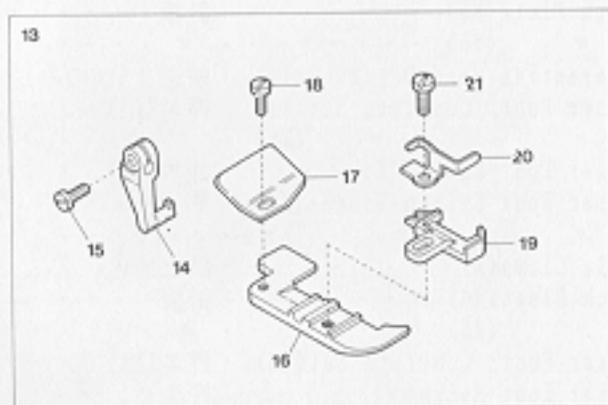
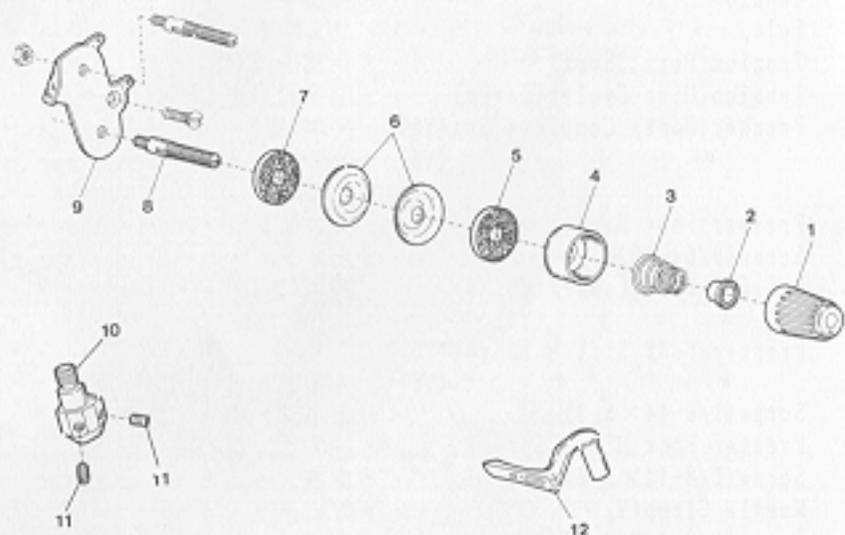

AZ6021H-A EXCLUSIVE PARTS

サブモデル専用部品

Ref. No.	Parts No.	Description	品名	Amt. Req.
1	0024084	Thread Tension Spring Cap	糸調子バネキャップ(上)	1
2	0024083	Tension Spring Bushing	糸調子ナット回り止メ	1
3	0032971	Needle Thread Tension Spring	針糸調子バネ	1
4	0020118	Thread Tension Spring Retainer	糸調子バネキャップ(下)	1
5	000178	Felt	フェルト	1
6	0031111	Tension Disc	糸調子皿	2
7	000177	Felt	フェルト	1
8	004265	Tension Post (Short)	糸調子棒(短)	1
9	2100074	Tension Disc Eyelet (Large)	調子台糸道(大)	1
10	2109135	Needle Clamp(A)	針止メ	1
11	003637	Screw(1/8-44x2.5)	止ネジ	2
12	2109341	Upper Looper(for Needle Size #9~14) 上ルーバ(針番手 #9~14用)	上ルーバ(針番手 #9~14用)	1
13	2107314	Presser Foot, Complete Set(A6)	押エ(組)	1
14	0024100	Presser Foot Hinge	押エヒンジ	1
15	004351	Screw(9/64-40x7)	止ネジ	1
16	2107282	Presser Foot(Lower)	押エ(下)	1
17	0034535	Presser Foot Chain Shield	空糸押エ	1
18	004237	Screw(3/32-56x2.6)	止ネジ	1
19	2107234	Presser Foot Stitch Tongue(A6)	爪	1
20	2107162	Presser Foot Hinge Spring	押エヒンジバネ	1
21	005036	Screw(1/8-44x5.6)	止ネジ	1
22	2108030	Stitch Plate(A6)	針板	1
23	2109202	Needle Guard(Front)	針受ケ(前)	1
24	2109052	Auxiliary Feed Dog	小送り	1

AZ6025H

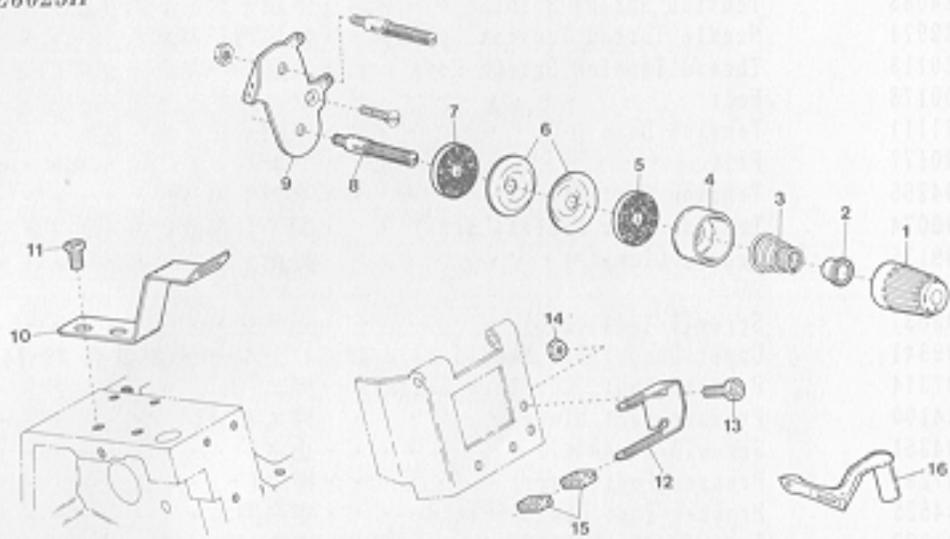

AZ6025H-Y5, Y6

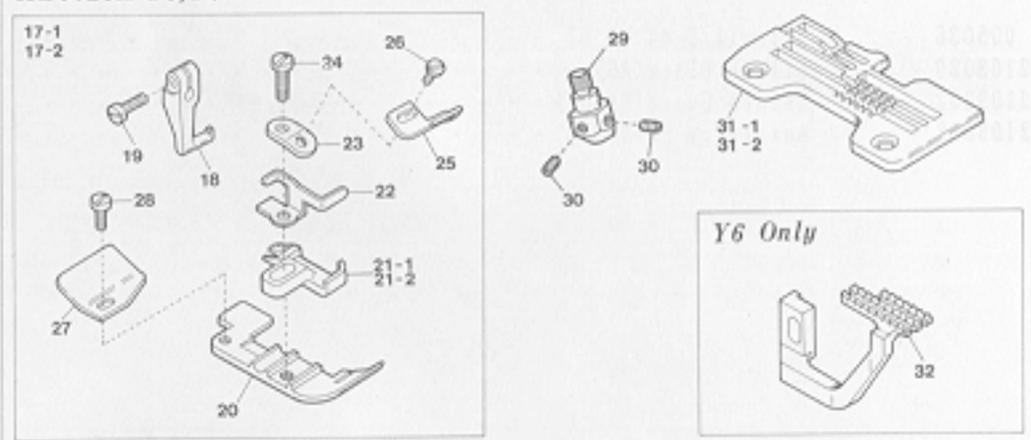

AZ6025H-X4

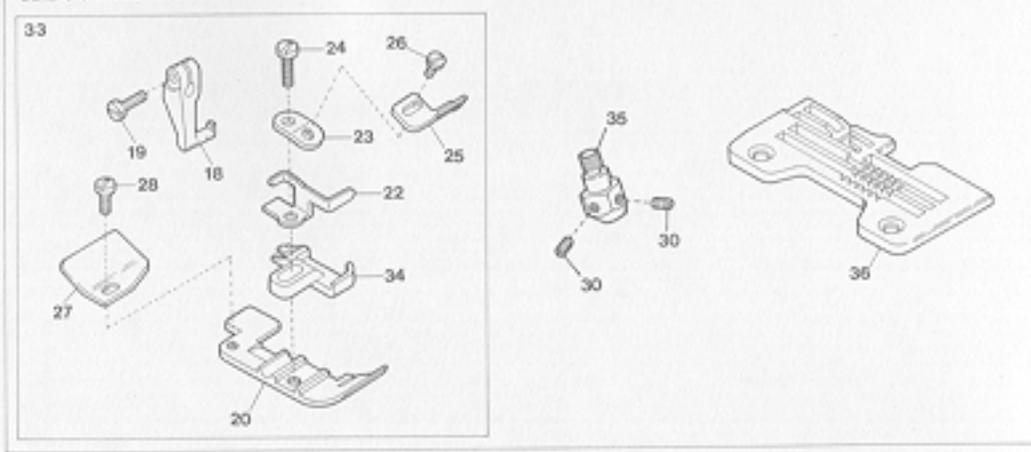

AZ6025H-Y, X EXCLUSIVE PARTS

サブモデル専用部品

Ref. No.	Parts No.	Description	品名	Amt. Req.
1	0024094	Thread Tension Spring Cap	糸調子バネキャップ(上)	1
2	0024083	Tension Spring Bushing	糸調子ナット回り止メ	1
3	0032971	Needle Thread Tension Spring	針糸調子バネ	1
4	0020118	Thread Tension Spring Retainer	糸調子バネキャップ(下)	1
5	000178	Felt	フェルト	1
6	0031111	Tension Disc	糸調子皿	2
7	000177	Felt	フェルト	1
8	004265	Tension Post(Short)	糸調子棒(短)	1
9	2100074	Tension Disc Eyelet(Large)	調子台糸道(大)	1
10	0024130	Tape Guide(Upper)	テープガイド(上)	1
11	110012	Screw(M4-0.7×5)	止ネジ	2
12	0024129	Tape Guide(Lower)	テープガイド(下)	1
13	110013	Screw(M4-0.7×8)	止ネジ	2
14	100001	Nut	ナット	2
15	0033738	Tape Guide Tube	テープ支エ	2
16	2109322	Upper Looter(for Needle Size #9~14)	上ルーバ(針番手 #9~14用)	1
17-1	2107308	Presser Foot, Complete Set(Y5)	押エ(組)	1
17-2	2107309	" " (Y6)	" "	1
18	0024100	Presser Foot Hinge	押エヒンジ	1
19	004351	Screw(9/64-40×7)	止ネジ	1
20	2107290	Presser Foot(Lower)	押エ(下)	1
21-1	2107240	Presser Foot Stitch Tongue(Y5)	爪	1
21-2	2107241	" " (Y6)	" "	1
22	2107162	Presser Foot Hinge Spring	押エヒンジバネ	1
23	2107173	Tape Guide Support	テープガイド取付板	1
24	210005	Screw(1/8-44×7.1)	止ネジ	1
25	2107174	Presser Foot Tape Guide	押エテープガイド	1
26	001228	Screw(3/32-56×3.2)	止ネジ	1
27	0034535	Presser Foot Chain Shield	空糸押エ	1
28	004237	Screw(3/32-56×2.6)	止ネジ	1
29	2109130	Needle Clamp(Y)	針止メ	1
30	003637	Screw(1/8-44×2.5)	止ネジ	2
31-1	2108004	Stitch Plate(Y5)	針板	1
31-2	2108005	" " (Y6)	" "	1
32	2109009	Differential Feed Dog(Y6 Only)	前送り(Y6のみ)	1
33	2107306	Presser Foot, Complete Set(X4)	押エ(組)	1
34	2107238	Presser Foot Stitch Tongue(X4)	爪	1
35	2109131	Needle Clamp(X)	針止メ	1
36	2108006	Stitch Plate(X4)	針板	1

AZ6032H, 6035H(1)

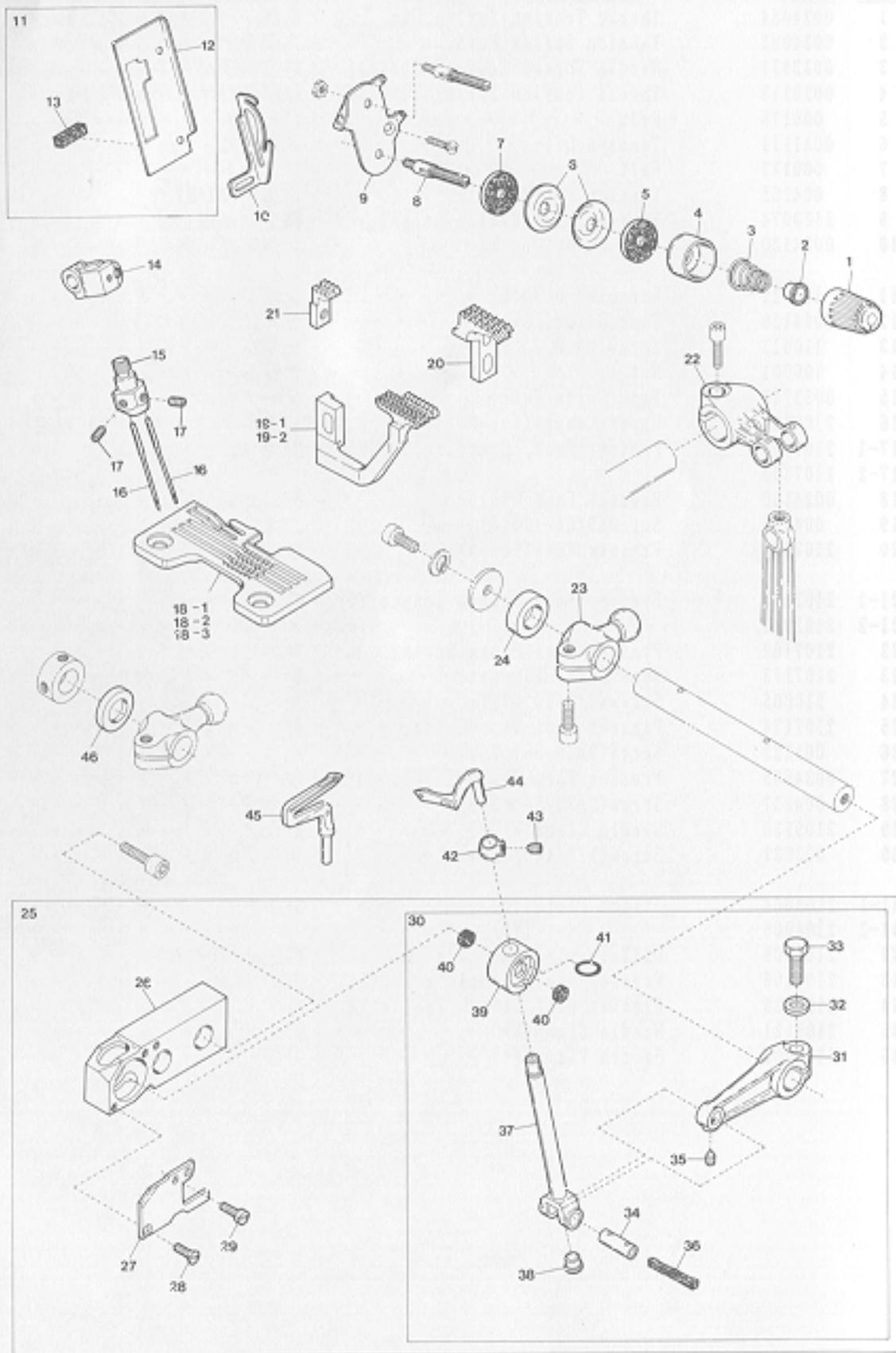

AZ6032H, 6035H EXCLUSIVE PARTS(1)

Ref. No.	Parts No.	Description	品名	Amt. Req.
1	0024084	Thread Tension Spring Cap	糸調子バネキャップ(上)	1
2	0024083	Tension Spring Bushing	糸調子ナット回り止メ	1
3	0032971	Needle Thread Tension Spring	針糸調子バネ	1
4	0020118	Thread Tension Spring Retainer	糸調子バネキャップ(下)	1
5	000178	Felt	フェルト	1
6	0031111	Tension Disc	糸調子皿	2
7	000177	Felt	フェルト	1
8	004265	Tension Post(Short)	糸調子棒(短)	1
9	2100074	Tension Disc Eyelet(Large)	調子台糸道(大)	1
10	2101140	Needle Thread Pull-off	針糸繰リ	1
11	2101431	Connecting Link Cover(Front), C. Set	針棒カバー(前)(組)	1
12	2101432	Connecting Link Cover(Front)	針棒カバー(前)	1
13	2101433	Needle Bar Oiling Felt(Front)	針棒フェルト(前)	1
14	2101407	Needle Bar Connecting Bracket	針棒抱キ	1
15	2109134	Needle Clamp(Y)	針止メ	1
16	---	Needle(System: DC×27)	針	2
17	003637	Screw(1/8-44×2.5)	止ネジ	2
18-1	2108062	Stitch Plate(Y5)	針板	1
18-2	2108063	" (Y6)	"	1
18-3	2108064	" (Y7)	"	1
19-1	2109084	Differential Feed Dog(Y5, Y6)	前送り	1
19-2	2109085	" " (Y7)	"	1
20	2109086	Main Feed Dog	後送り	1
21	2109052	Auxiliary Feed Dog	小送り	1
22	2101405	Needle Bar Driving Lever	針棒クランク軸腕	1
23	2101141	Upper Looper Driving Lever	上ルーパー軸腕	1
24	2101142	Driving Shaft Thrust Ring	上ルーパースラストリング	1
25	2101146	Upper Looper Bar Crank Arm, C. Set	上ルーパークランク(組)	1
26	2100226	Upper Looper Bar Guide Bushing	ルーパー案内メタル	1
27	2100227	Upper Looper Bar Guide Cover	ルーパー案内蓋	1
28	130001	Screw(M2.5-0.45×6)	止ネジ	1
29	110071	Screw(M2.5-0.45×6)	止ネジ	1
30	2101147	Upper Looper Bar Guide, Complete Set	ルーパー案内(組)	1
31	2101089	Upper Looper Bar Crank Arm	上ルーパークランク	1
32	300008	Washer	ワッシャ	1
33	140002	Screw(M6-1×14)	止ネジ	1
34	2100176	Upper Looper Bar Crank Arm Pin	上ルーパークランクピン	1
35	160002	Screw(M4-0.7×5)	止ネジ	1
36	310048	Oil Wick	油芯	1
37	2100506	Upper Looper Bar Unit	ルーパー棒(組)	1
38	330011	Seal Plug	詰栓	1
39	2100565	Upper Looper Bar Guide	ルーパー案内	1
40	310049	Oiling Felt	フェルト	2
41	0020538	O-ring(P7)	Oリング	1
42	2100516	Upper Looper Holder Collar	上ルーパー止メカラー	1
43	160010	Screw(M4-0.7×3)	止ネジ	1
44	2109342	Upper Looper(for Needle Size #11~14)	上ルーパー(針番手#11~14用)	1
45	2109331	Lower Looper	下ルーパー	1
46	2101143	Lower Looper Driving Shaft Thrust Ring	下ルーパースラストリング	1

AZ6032H(2)

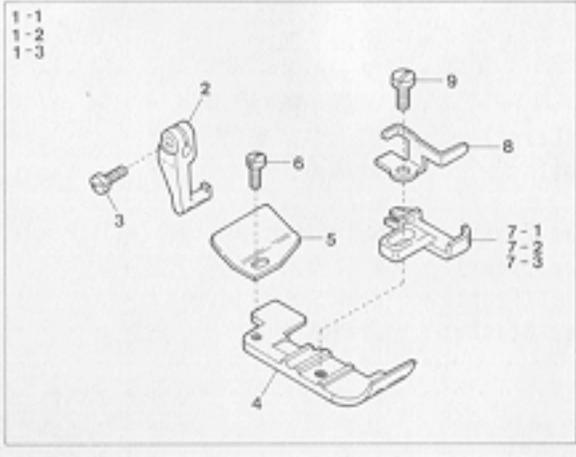

AZ6035H(2)

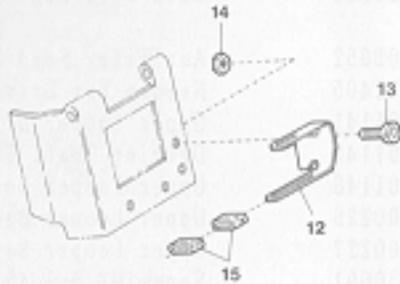
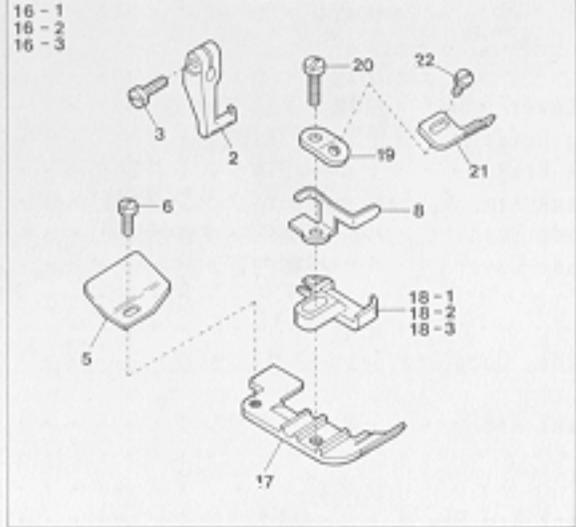
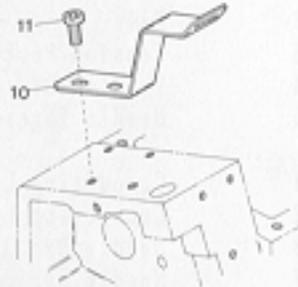

EXTRA PARTS

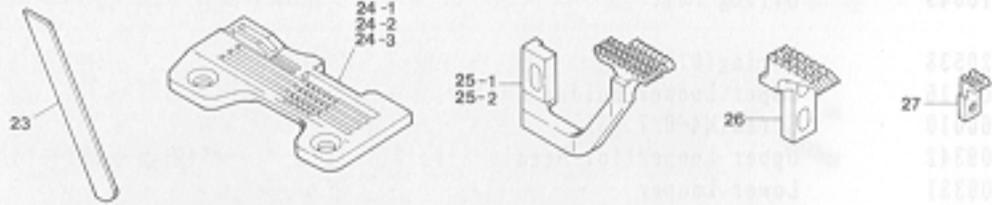

AZ6032H, 6035H EXCLUSIVE PARTS(2)

サブモデル専用部品(2)

Ref. No	Parts No	Description	品名	Amt.	Req.
1-1	2107347	Presser Foot, Complete Set (Y5)	押エ(組)	1	1
1-2	2107348	" " " " (Y6)	"	1	1
1-3	2107349	" " " " (Y7)	"	1	1
2	0024100	Presser Foot Hinge	押エヒンジ	1	1
3	004351	Screw(9/64-40x7)	止ネジ	1	1
4	2107289	Presser Foot (Lower)	押エ(下)	1	1
5	0034535	Presser Foot Chain Shield	空糸押エ	1	1
6	004237	Screw(3/32-56x2.6)	止ネジ	1	1
7-1	2107244	Presser Foot Stitch Tongue (Y5)	爪	1	1
7-2	2107245	" " " " (Y6)	"	1	1
7-3	2107246	" " " " (Y7)	"	1	1
8	2107162	Presser Foot Hinge Spring	押エヒンジバネ	1	1
9	005036	Screw(1/8-44x5.6)	止ネジ	1	1
10	0024130	Tape Guide (Upper)	テープガイド(上)	1	1
11	110012	Screw(M4-0.7x5)	止ネジ	2	1
12	0024129	Tape Guide (Lower)	テープガイド(下)	1	2
13	110013	Screw(M4-0.7x8)	止ネジ	2	2
14	100001	Nut	ナット	2	2
15	0033738	Tape Guide Tube	テープ支エ	1	1
16-1	2107332	Presser Foot, Complete Set (Y5)	押エ(組)	1	1
16-2	2107333	" " " " (Y6)	"	1	1
16-3	2107334	" " " " (Y7)	"	1	1
17	2107284	Presser Foot (Lower)	押エ(下)	1	1
18-1	2107240	Presser Foot Stitch Tongue (Y5)	爪	1	1
18-2	2107241	" " " " (Y6)	"	1	1
18-3	2107242	" " " " (Y7)	"	1	1
19	2107173	Tape Guide Support	テープガイド取付板	1	1
20	210005	Screw(1/8-44x7.1)	止ネジ	1	1
21	2107174	Presser Foot Tape Guide	押エテープガイド	1	1
22	001228	Screw(3/32-56x3.2)	止ネジ	1	1
23	2101091	Lower Knife	下メス	1	1
24-1	2108043	Stitch Plate (Y5)	針板	1	1
24-2	2108044	" " (Y6)	"	1	1
24-3	2108045	" " (Y7)	"	1	1
25-1	2109033	Differential Feed Dog (Y5)	前送り	1	1
25-2	2109030	" " " " (Y6, Y7)	"	1	1
26	2109031	Main Feed Dog	後送り	1	1
27	2109032	Auxiliary Feed Dog	小送り	1	1



AZ6035H-54(1)

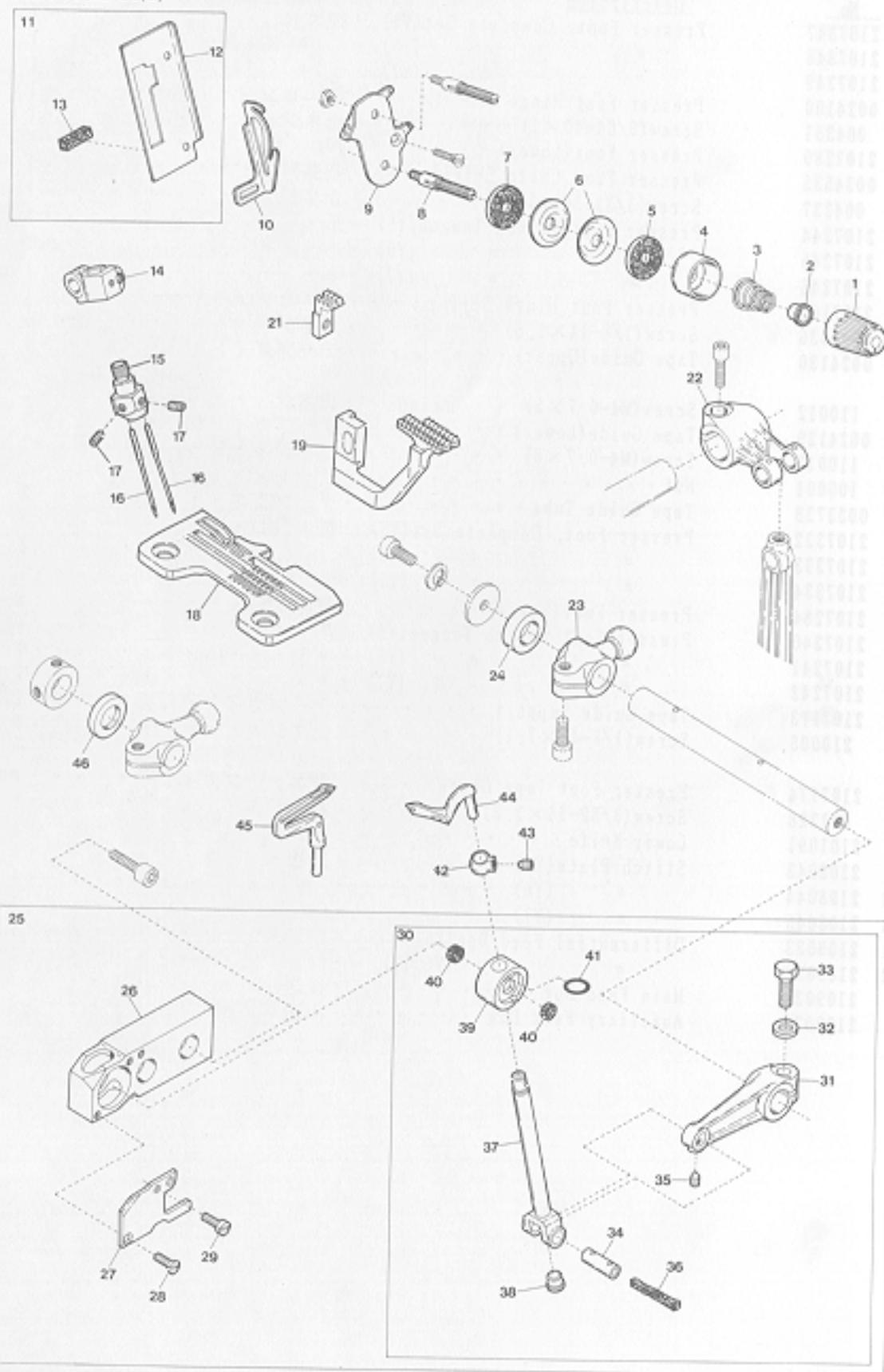

AZ6035H-54 EXCLUSIVE PARTS(1)

サブモデル専用部品(1)

29

Ref. No.	Parts No.	Description	品名	Ant. Req.
1	0024084	Thread Tension Spring Cap	糸調子バネキャップ(上)	1
2	0024083	Tension Spring Bushing	糸調子ナット回り止メ	1
3	0032971	Needle Thread Tension Spring	針糸調子バネ	1
4	0020118	Thread Tension Spring Retainer	糸調子バネキャップ(下)	1
5	000178	Felt	フェルト	1
6	0031111	Tension Disc	糸調子皿	2
7	000177	Felt	フェルト	1
8	004265	Tension Post(Short)	糸調子棒(短)	1
9	2100074	Tension Disc Eyelet(Large)	調子台糸道(大)	1
10	2101140	Needle Thread Pull-off	針糸繰り	1
11	2101431	Connecting Link Cover(Front), C. Set	針棒カバー(前)(組)	1
12	2101432	Connecting Link Cover(Front)	針棒カバー(前)	1
13	2101433	Needle Bar Oiling Felt(Front)	針棒フェルト(前)	1
14	2101407	Needle Bar Connecting Bracket	針棒抱キ	1
15	2109134	Needle Clamp(Y)	針止メ	1
16	---	Needle(System: DC×27)	針	2
17	003637	Screw(1/8-44×2.5)	止ネジ	2
18	2128010	Stitch Plate(Y7)	針板	1
19	2109009	Differential Feed Dog(for 06)	前送り(06用)	1
20	---	---	---	---
21	2109052	Auxiliary Feed Dog	小送り	1
22	2101405	Needle Bar Driving Lever	針棒クランク軸腕	1
23	2101141	Upper Looper Driving Lever	上ルーバ軸腕	1
24	2101142	Driving Shaft Thrust Ring	上ルーバスラストリング	1
25	2101146	Upper Looper Bar Crank Arm, C. Set	上ルーバクランク(組)	1
26	2100226	Upper Looper Bar Guide Bushing	ルーバ案内メタル	1
27	2100227	Upper Looper Bar Guide Cover	ルーバ案内蓋	1
28	130001	Screw(M2.5-0.45×6)	止ネジ	1
29	110071	Screw(M2.5-0.45×6)	止ネジ	1
30	2101147	Upper Looper Bar Guide, Complete Set	ルーバ案内(組)	1
31	2101089	Upper Looper Bar Crank Arm	上ルーバクランク	1
32	300008	Washer	ワッシャ	1
33	140002	Screw(M6-1×14)	止ネジ	1
34	2100176	Upper Looper Bar Crank Arm Pin	上ルーバクランクピン	1
35	160002	Screw(M4-0.7×5)	止ネジ	1
36	310048	Oil Wick	油芯	1
37	2100506	Upper Looper Bar Unit	ルーバ棒(組)	1
38	330011	Seal Plug	詰栓	1
39	2100565	Upper Looper Bar Guide	ルーバ案内	1
40	310049	Oiling Felt	フェルト	2
41	0020538	O-ring(P7)	Oリング	1
42	0021705	Upper Looper Holder Collar	上ルーバ止メカラー	1
43	004144	Screw(11/64-40×5)	止ネジ	1
44	2109342	Upper Looper(for Needle Size #11-14)	上ルーバ(針番手#11~14用)	1
45	2109331	Lower Looper	下ルーバ	1
46	2101143	Lower Looper Driving Shaft Thrust Ring	下ルーバスラストリング	1

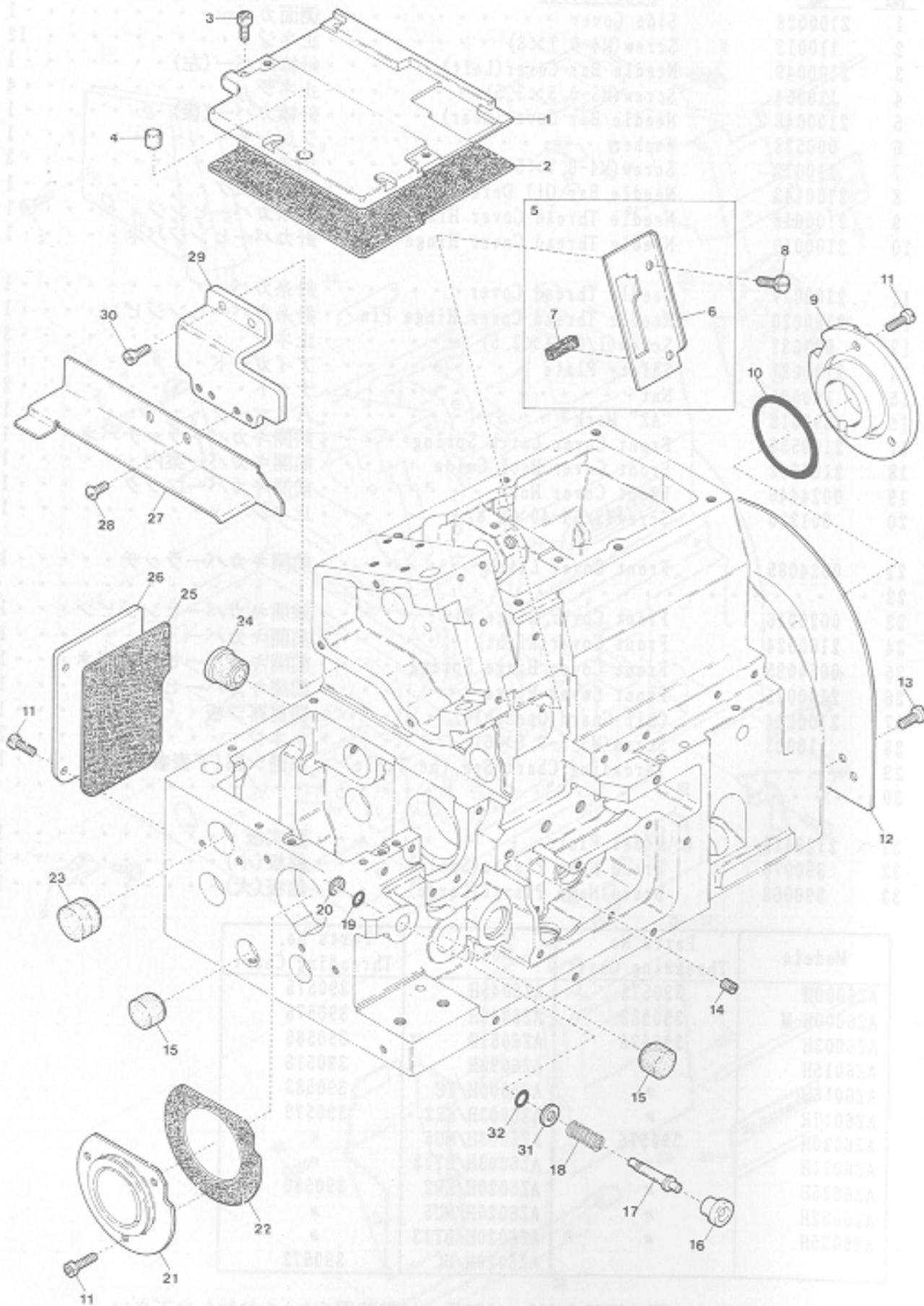

MISCELLANEOUS COVERS(3)

Ref. No	Parts No	Description	品名	Amt.	Req.
1	2100035	Feed Mechanism Cover	送り上カバー	1	3
2	2100036	Feed Mechanism Cover Gasket	送り上カバーパッキン	1	
3	110048	Screw(M4-0.7×10)	止ネジ	5	
4	2100047	Rubber Cushion	埋メ座(中)	1	
5	2100525	Connecting Link Cover(Front), C. Set	針棒カバー(前)(組)	1	
6	2100039	Connecting Link Cover(Front)	針棒カバー(前)	1	
7	2100526	Needle Bar Oiling Felt(Front)	針棒フェルト(前)	1	
8	110001	Screw(M4-0.7×5.4)	止ネジ	2	
9	2100093	Ball Bearing Holder	ベアリング押エ	1	
10	2100122	O-ring(P35)	Oリング	1	
11	110013	Screw(M4-0.7×8)	止ネジ	10	
12	2100318	Fan Cover	ファンカバー	1	
13	110012	Screw(M4-0.7×5)	止ネジ	2	
14	150001	Screw(M4-0.7×4)	止ネジ	1	
15	0020052	Seal Plug	詰栓	2	
16	2100045	Pushbutton	プッシュボタン	1	
17	2100044	Pushbutton Pin	プッシュボタン軸	1	
18	2100043	Pushbutton Spring	プッシュボタンバネ	1	
19	0020472	O-ring(P6)	Oリング	1	
20	0033024	Retaining Ring	ストッピング	1	
21	2100041	Ball Bearing Housing	ハウジング	1	
22	2100042	Ball Bearing Housing Gasket	ハウジングパッキン	1	
23	0036518	Seal Plug	詰栓	1	
24	2100110	Seal Plug	詰栓	1	
25	2100038	Tail Cover Gasket	後カバーパッキン	1	
26	2100037	Tail Cover	後カバー	1	
27	2100029	Fabric Guide Plate	布案内板	1	
28	001331	Screw(9/64-40×3.8)	止ネジ	2	
29	2100030	Fabric Guide Plate Support	布案内台	1	
30	110009	Screw(M4-0.7×8)	止ネジ	2	
31	000520	Washer	ワッシャ	1	
32	2100080	O-ring(S6)	Oリング	1	

AZ6035H-54(2)

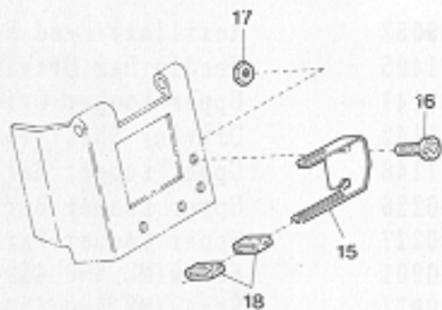
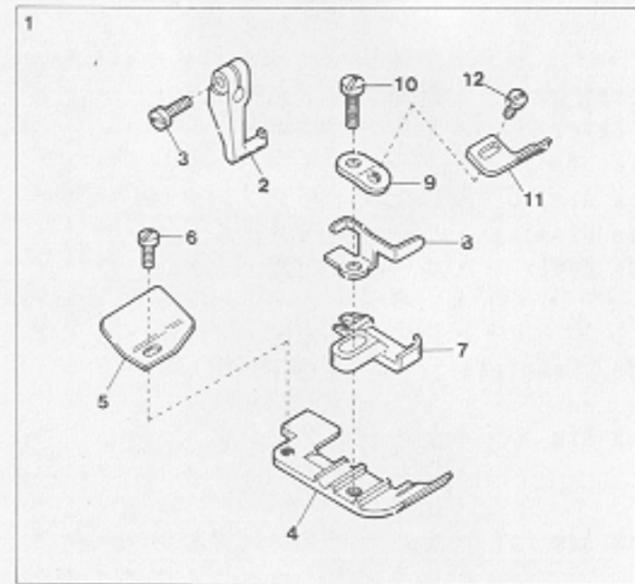
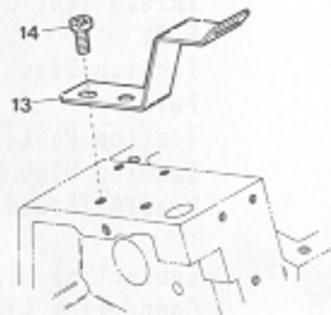

AZ6035H-54 EXCLUSIVE PARTS(2)

サブモデル専用部品(2)

Ref. No.	Parts No.	Description	品名	Amt. Req.
1	2107334	Presser Foot, Complete Set(Y7)	押エ(組)	1
2	0024100	Presser Foot Hinge	押エヒンジ	1
3	004351	Screw(9/64-40×7)	止ネジ	1
4	2107284	Presser Foot(Lower)	押エ(下)	1
5	0034535	Presser Foot Chain Shield	空糸押エ	1
6	004237	Screw(3/32-56×2.6)	止ネジ	1
7	2107242	Presser Foot Stitch Tongue(Y7)	爪	1
8	2107162	Presser Foot Hinge Spring	押エヒンジバネ	1
9	2107173	Tape Guide Support	テープガイド取付板	1
10	210005	Screw(1/8-44×7.1)	止ネジ	1
11	2107174	Presser Foot Tape Guide	押エテープガイド	1
12	001228	Screw(3/32-56×3.2)	止ネジ	1
13	0024130	Tape Guide(Upper)	テープガイド(上)	1
14	110012	Screw(M4-0.7×5)	止ネジ	2
15	0024129	Tape Guide(Lower)	テープガイド(下)	1
16	110013	Screw(M4-0.7×8)	止ネジ	2
17	100001	Nut	ナット	2
18	0033738	Tape Guide Tube	テープ支エ	2

(注) カラーの寸法は内径×外径×幅を表しています。
 (Note) Use of Collar Inside dia. × Outside dia. × Width

AZ6045H, 6046H(1)

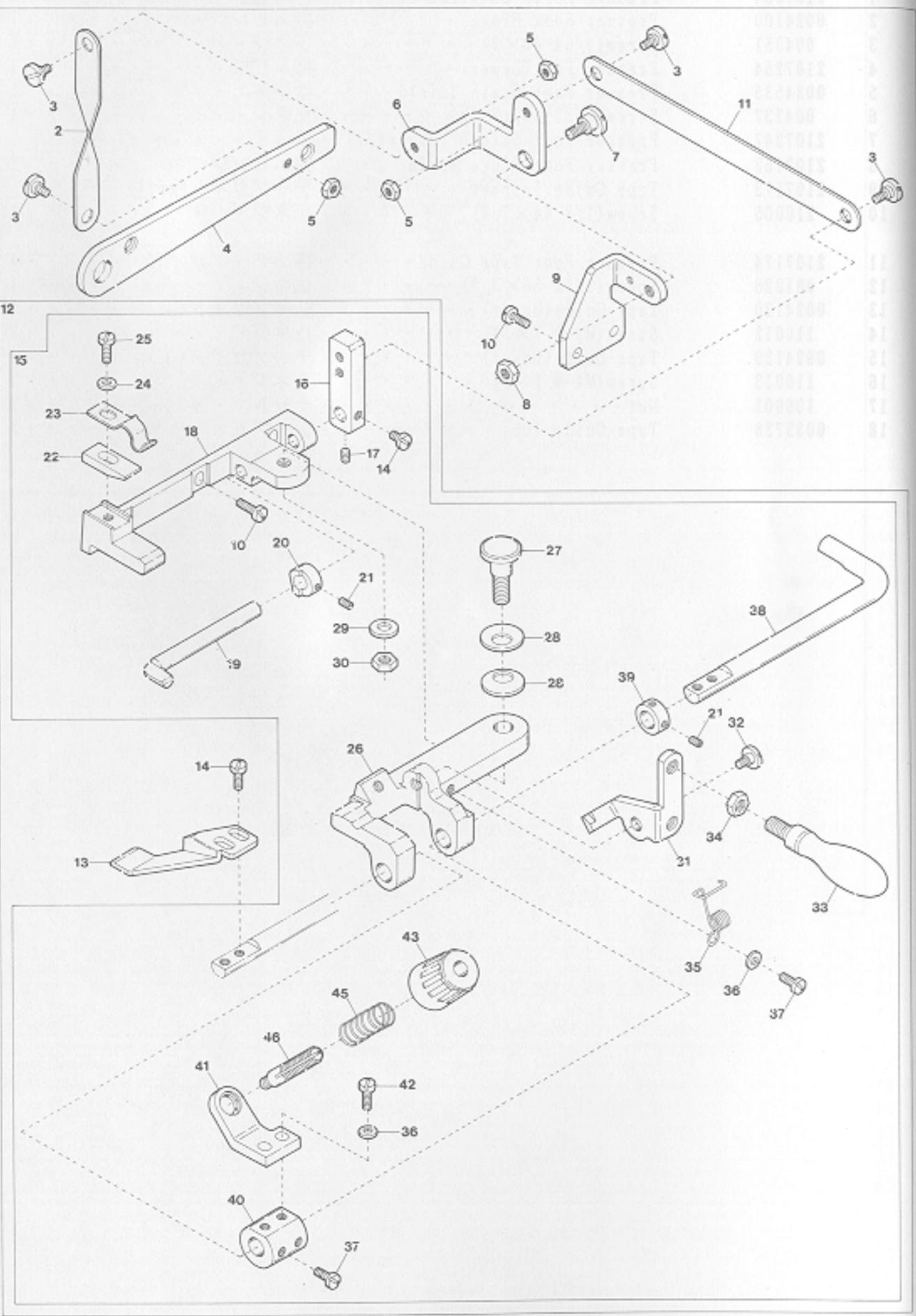

AZ6045H, 6046H EXCLUSIVE PARTS(1)

サブモデル専用部品(1)

Ref. No.	Parts No.	Description	品名	Amt. Req.
1	2101240	Ruffling Mechanism, C. Set(3)	ラフリング装置(組3)	1
2	2101243	Connecting Plate(Short)	連結板(短)	1
3	170005	Screw(M4-0.7×6)	止ネジ	4
4	2120111	Presser Foot Lifter Lever	押エ揚ゲレバー	1
5	100001	Nut	ナット	3
6	2101241	Connecting Plate Lever	連結板レバー	1
7	170031	Screw(M5-0.8×8.5)	止ネジ	1
8	100002	Nut	ナット	1
9	2101242	Connecting Plate Lever Support	連結板レバー取付台	1
10	110047	Screw(M4-0.7×10)	止ネジ	4
11	2101244	Connecting Plate(Long)	連結板(長)	1
12	2101246	Ruffling Mechanism, C. Set(2)	ラフリング装置(組2)	1
13	2101260	Ruffling Presser	ラフリング押エ	1
14	110001	Screw(M4-0.7×5.4)	止ネジ	3
15	2101245	Ruffling Mechanism, C. Set(1)	ラフリング装置(組1)	1
16	2101259	Ruffling Presser Lifter Shaft Lever	ラフリング押エ揚ゲ軸レバー	1
17	160001	Screw(M4-0.7×4)	止ネジ	1
18	2101248	Bracket Holder	ブラケット取付台	1
19	2101258	Ruffling Presser Lifter Shaft	ラフリング押エ揚ゲ軸	1
20	0020616	Step Collar	ストッパカラー	1
21	003637	Screw(1/8-44×25)	止ネジ	3
22	2101249	Bracket Fixing Piece	ブラケット固定片	1
23	2101250	Bracket Spring Plate	ブラケット止メバネ	1
24	000538	Washer	ワッシャ	1
25	110031	Screw(M4-0.7×12)	止ネジ	1
26	2101247	Bracket	ブラケット	1
27	005589	Screw(1/4-40×14.5)	止ネジ	1
28	000621	Conical Spring Washer	皿バネワッシャ	2
29	000613	Washer	ワッシャ	1
30	000306	Nut	ナット	1
31	2101252	Handle Holder	押エ揚ゲハンドル取付台	1
32	170032	Screw(M4-0.7×5)	止ネジ	1
33	2101255	Ruffling Swing-out Handle	押エ揚ゲハンドル	1
34	000234	Nut	ナット	1
35	2101253	Swing-out Handle Holder Spring	ハンドル取付台バネ	1
36	000530	Washer	ワッシャ	3
37	007627	Screw(M4-0.7×6)	止ネジ	3
38	2101257	Ruffling Presser Shaft	ラフリング押エ軸	1
39	0094562	Collar(8×13×6mm)	カラー	1
40	2101254	Lifter Lever Holder	ラフリング押エ揚ゲレバー取付台	1
41	2101251	Ruffling Presser Lifter Lever	ラフリング押エ揚ゲレバー	1
42	110009	Screw(M4-0.7×8)	止ネジ	2
43	0093863	Spring Cap	押エバネキャップ	1
44				
45	2101268	Ruffling Presser Spring	ラフリング押エバネ	1
46	004125	Tension Post	調子棒	1

(注) カラーの寸法は内径×外径×幅を表しています。
 Note: Size of Collar Inside dia.×Outside dia.×Thickness

AZ6045H(2)

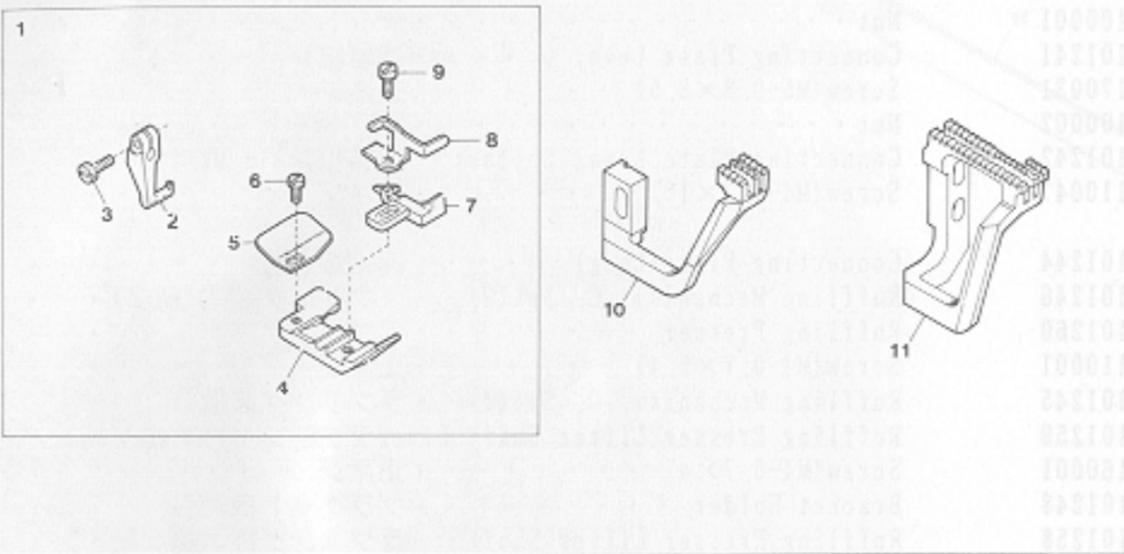

AZ6045H EXCLUSIVE PARTS(2)

Ref. No.	Parts No.	Description	品名	Amt. Req.
1	0024354	Presser Foot, Complete Set(04)	押エ(組)	1
2	0024100	Presser Foot Hinge	押エヒンジ	1
3	004351	Screw(9/64-40x7)	止ネジ	1
4	0022153	Presser Foot(Lower)	押エ(下)	1
5	0034535	Presser Foot Chain Shield	空糸押エ	1
6	004237	Screw(3/32-56x2.6)	止ネジ	1
7	0021876	Presser Foot Stitch Tongue(04)	爪	1
8	0021005	Presser Foot Hinge Spring	押エヒンジバネ	1
9	004131	Screw(1/8-44x6)	止ネジ	1
10	2109020	Differential Feed Dog	前送り	1
11	2109021	Main Feed Dog	後送り	1

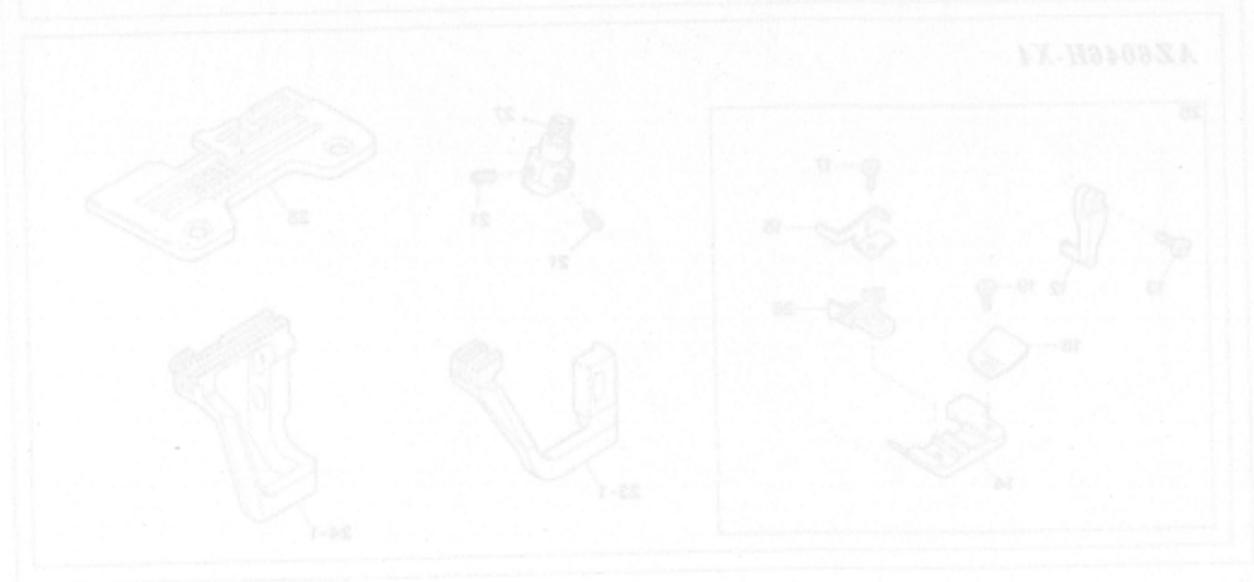

AZ6046H(2)

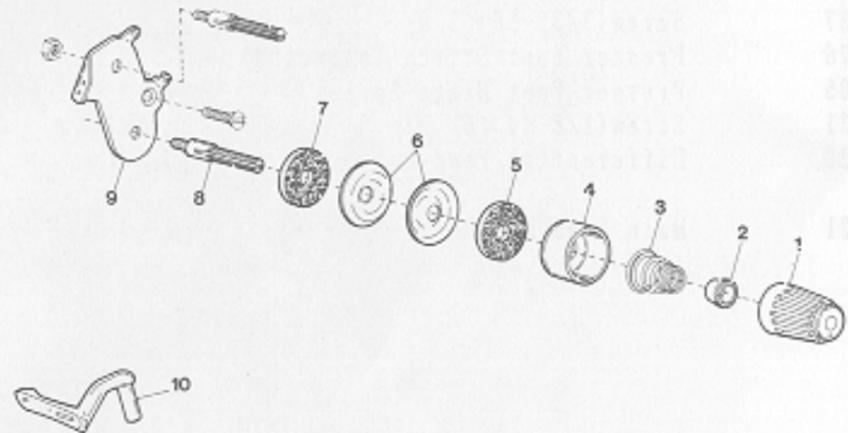

AZ6046H-Y5, Y6

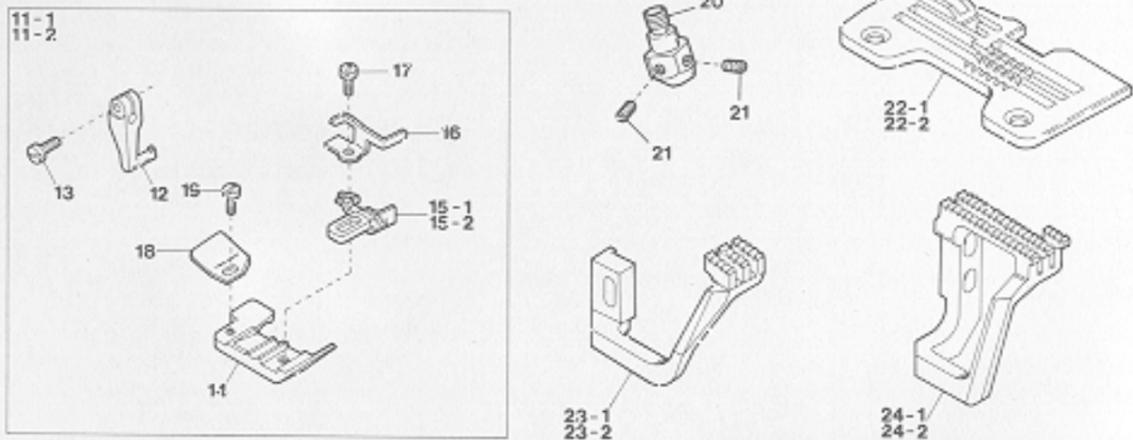

AZ6046H-X4

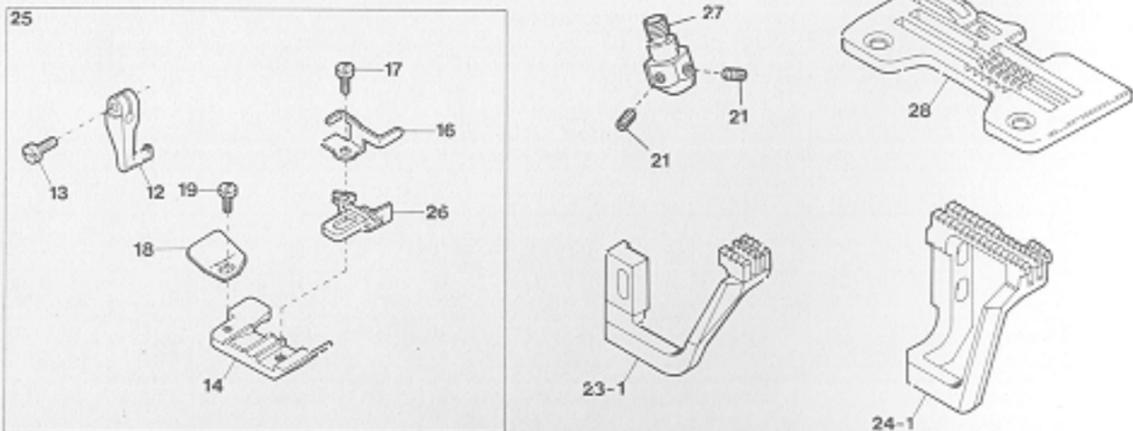

AZ6046H EXCLUSIVE PARTS(2)

サブモデル専用部品(2)

Ref. No.	Parts No.	Description	品名	Amt. Req.
1	0024084	Thread Tension Spring Cap	糸調子バネキャップ(上)	1
2	0024083	Tension Spring Bushing	糸調子ナット回り止メ	1
3	0032971	Needle Thread Tension Spring	針糸調子バネ	1
4	0020118	Thread Tension Spring Retainer	糸調子バネキャップ(下)	1
5	000178	Felt	フェルト	1
6	0031111	Tension Disc	糸調子皿	2
7	000177	Felt	フェルト	1
8	004265	Tension Post (Short)	糸調子棒(短)	1
9	2100074	Tension Disc Eyelet (Large)	調子台糸道(大)	1
10	2109322	Upper Looper(for Needle Size #9~14)上ルーバ(針番手 #9~14用)		1
11-1	2107059	Presser Foot, Complete Set (Y5)	押エ(組)	1
11-2	2107390	" " (Y6)	"	1
12	0024100	Presser Foot Hinge	押エヒンジ	1
13	004351	Screw(9/64-40×7)	止ネジ	1
14	0022153	Presser Foot (Y6)	押エ	1
15-1	2107068	Presser Foot Stitch Tongue (Y5)	爪	1
15-2	0021879	" " (Y6)	"	1
16	2107162	Presser Foot Hinge Spring	押エヒンジバネ	1
17	004131	Screw(1/8-44×5.6)	止ネジ	1
18	0034535	Presser Foot Chain Shield	空糸押エ	1
19	004237	Screw(3/32-56×2.6)	止ネジ	1
20	2109130	Needle Clamp (Y)	針止メ	1
21	003637	Screw(1/8-44×2.5)	止ネジ	2
22-1	2108004	Stitch Plate (Y5)	針板	1
22-2	2108005	" (Y6)	"	1
23-1	2109020	Differential Feed Dog (Y5, X4)	前送り	1
23-2	2109022	" " (Y6)	"	1
24-1	2109021	Main Feed Dog (Y5, X4)	後送り	1
24-2	2109023	" (Y6)	"	1
25	2107389	Presser Foot, Complete Set (X4)	押エ(組)	1
26	2107250	Presser Foot Stitch Tongue (X4)	爪	1
27	2109131	Needle Clamp (X)	針止メ	1
28	2108006	Stitch Plate	針板	1

AZ6051H(1)

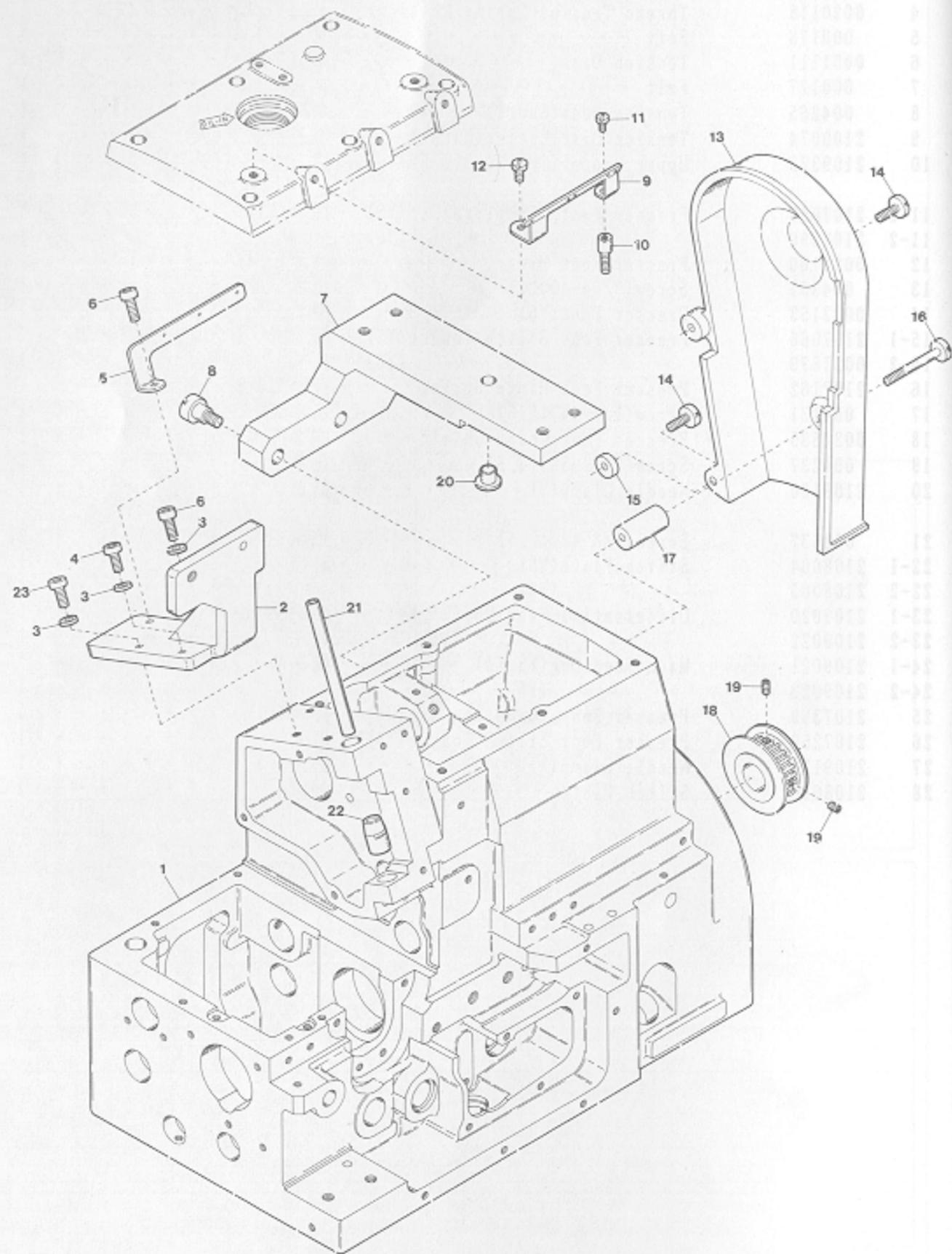

AZ6051H EXCLUSIVE PARTS(1)

Ref. No.	Parts No.	Description	品名	Amt. Req.
1	2101462	Machine Frame	フレーム	1
2	2101571	Tension Roller Bracket	ローラ台取付台	1
3	000665	Washer	ワッシャ	3
4	120018	Screw(M4-0.7×12)	止ネジ	1
5	2101573	Thread Guide Plate(Rear)	糸案内板(後)	1
6	120001	Screw(M4-0.7×14)	止ネジ	2
7	2101570	Bracket	ゼロマックス取付台	1
8	170034	Screw(M6-1×9)	止ネジ	2
9	2101572	Thread Guide Plate(Front)	糸案内板(前)	1
10	190046	Screw(M4-0.7×15)	止ネジ	1
11	110003	Screw(M3.5-0.6×6)	止ネジ	1
12	110013	Screw(M4-0.7×8)	止ネジ	1
13	2101574	Timing Belt Cover	タイミングベルトカバー	1
14	110074	Screw(M4-0.7×12.5)	止ネジ	2
15	300028	Spacer	スペーサ	1
16	110075	Screw(M4-0.7×10)	止ネジ	1
17	2101575	Timing Belt Cover Spacer	タイミングベルトカバースペーサ	1
18	2101463	Timing Pulley(Small)	タイミングプーリ(小)	1
19	009736	Screw(M4-0.7×6)	止ネジ	2
20	2101576	Bracket Stay	取付台支エ	1
21	2100642	Needle Bar	針棒	1
22	2100641	Needle Bar Bushing(Lower)	止ネジ	1
23	120009	Screw(M4-0.7×12)	止ネジ	1
15	005005	Screw(1/4-40×12.5)	止ネジ	1
16	000528	Washer	ワッシャ	1
17	003156	Screw(11/64-40×18.3)	止ネジ	1
18	2101578	Connector Case Support	コネクタケース取付板	1
19	120023	Screw(M4-0.7×8)	止ネジ	1
20	000665	Washer	ワッシャ	1
21	004127	Screw(M4-0.7×8)	止ネジ	1
22	2101581	Rubber Cushion	防振ゴム	1
23	2101582	Universal Joint	ユニバーサルジョイント	1

サブモデル専用部品(1)

34

Amt.
Req.

051H(2)

with "MT2" Device

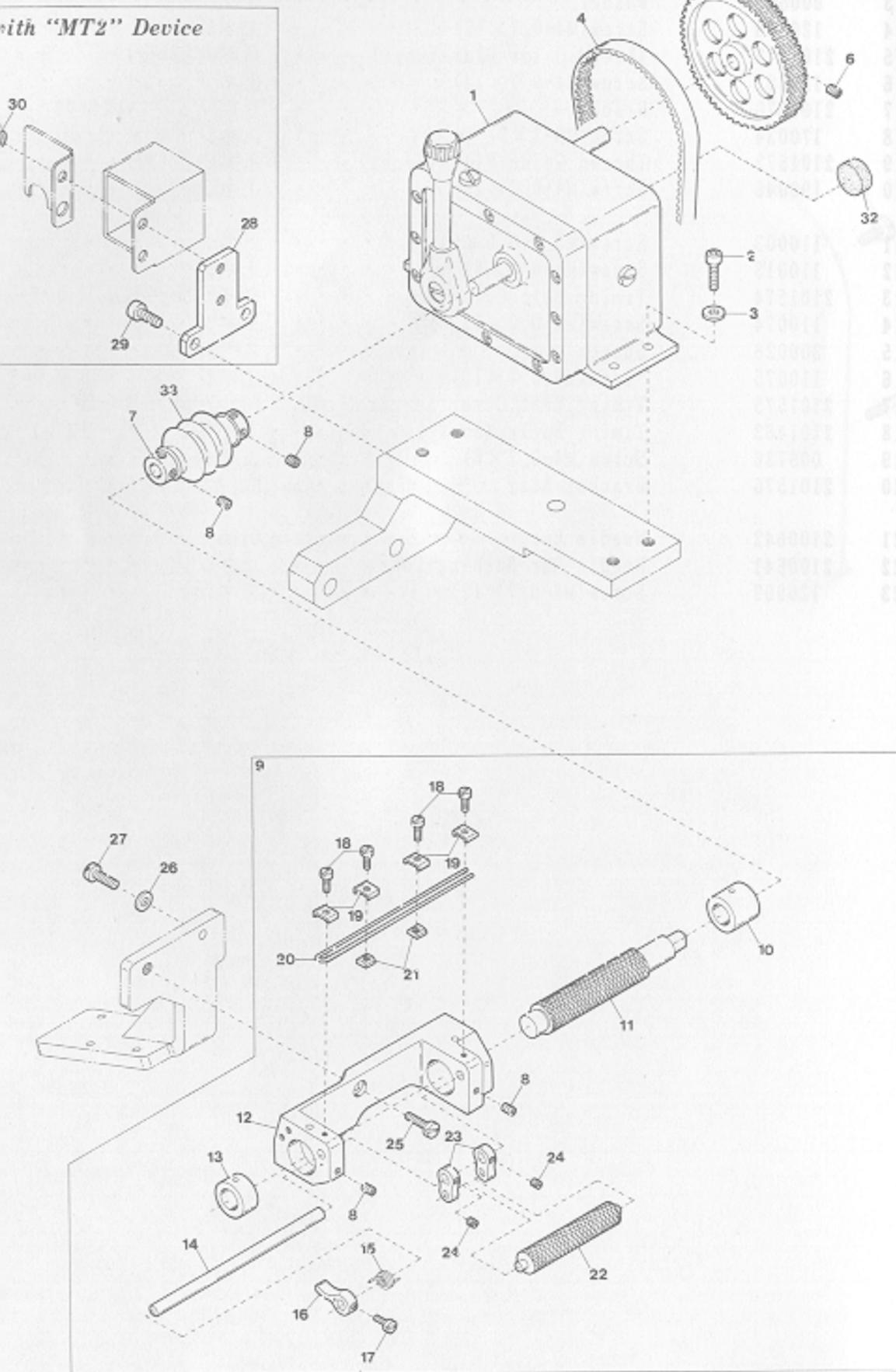

AZ6051H EXCLUSIVE PARTS(2)

サブモデル専用部品(2) 35

Ref. No.	Parts No.	Description	品名	Amt. Req.
1	0036820	"ZERO-MAX" (E2 Type)	ゼロマックス(E2型)	1
2	120013	Screw(M6-1×15)	止ネジ	4
3	000613	Washer	ワッシャ	4
4	2101579	Timing Belt	タイミングベルト	1
5	0036816	Timing Pulley(Large)	タイミングプーリ(大)	1
6	003635	Screw(1/4-40×6)	止ネジ	2
7	2101577	Universal Joint	ユニバーサルジョイント	1
8	003638	Screw(11/64-40×4)	止ネジ	6
9	2101580	Tension Roller, Complete Set	ローラ台(組)	1
10	0095068	Clutch Frame Bushing(Right)	ローラ台ブッシュ(右)	1
11	0036827	Tension Roller(Large)	ローラ(大)	1
12	0095072	Clutch Frame	ローラ台	1
13	0095069	Clutch Frame Bushing(Left)	ローラ台ブッシュ(左)	1
14	0094548	Tension Link Shaft	リンクシャフト	1
15	0091932	Tension Link Shaft Spring	リンクシャフトバネ	1
16	0094549	Spring Latch	バネ掛ケ	1
17	009604	Screw(11/64-40×5.5)	止ネジ	1
18	001196	Screw(1/8-44×6)	止ネジ	4
19	0094556	Tape Guide Washer	テープガイドワッシャ	4
20	0094553	Tape Guide	テープガイド	1
21	0094557	Tape Guide Nut	テープガイドナット	2
22	0094546	Tension Roller(Small)	ローラ(小)	1
23	0094547	Tension Link	ローラリンク	2
24	001457	Screw(11/64-40×3.3)	止ネジ	2
25	005089	Screw(1/4-40×12.5)	止ネジ	1
26	000538	Washer	ワッシャ	1
27	001156	Screw(11/64-40×13.3)	止ネジ	1
28	2101578	Connector Case Support	コネクタケース取付板	1
29	110009	Screw(M4-0.7×8)	止ネジ	2
30	000665	Washer	ワッシャ	2
31	004127	Screw(M4-0.7×6)	止ネジ	2
32	2101581	Rubber Cushion	防振ゴム	1
33	2101582	Universal Joint Cover	ユニバーサルジョイントカバー	1

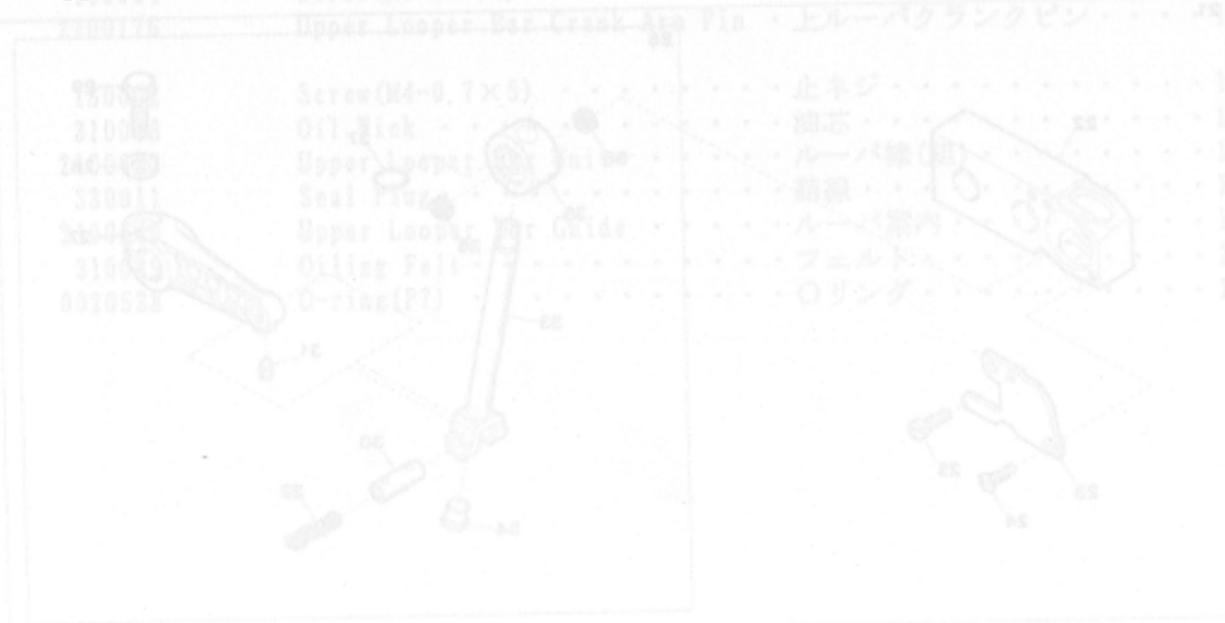

AZ6051H(3)

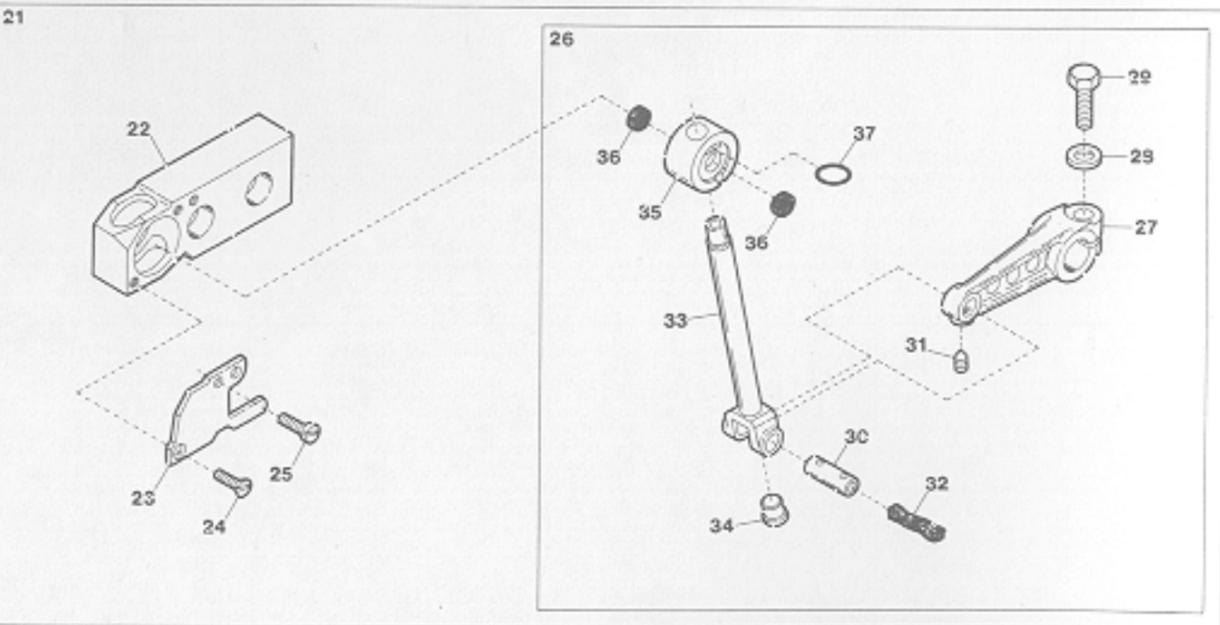
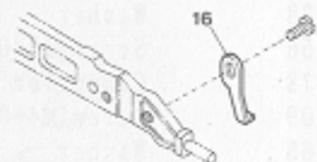
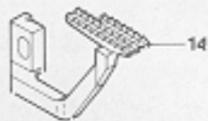
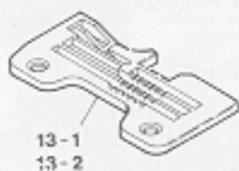
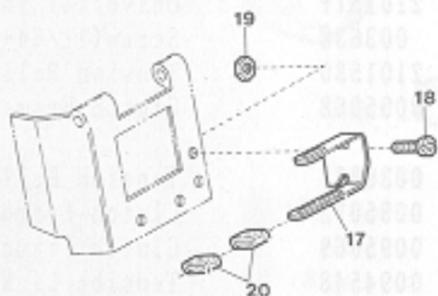
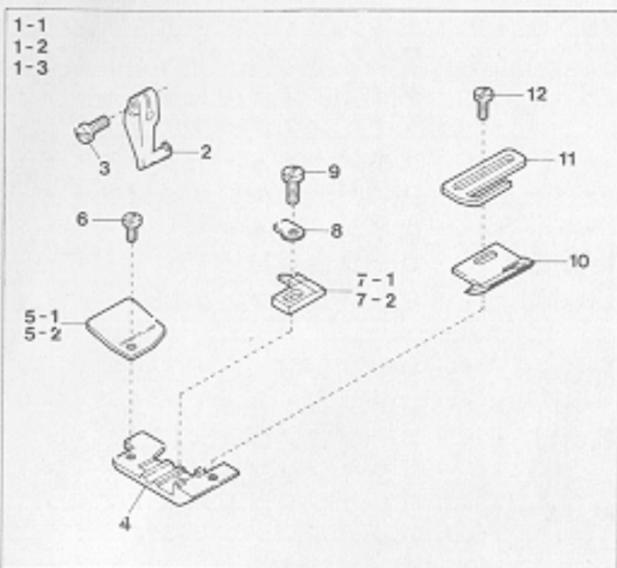

AZ6051H EXCLUSIVE PARTS (3)

Ref. No.	Parts No.	Description	品名	Amt. Req.
1-1	2107385	Presser Foot, Complete Set (04)	押エ(組)	1
1-2	2107386	" " (05)	" "	1
1-3	2107305	" " (04) (with MT2)	押エ(組)	1
2	0024100	Presser Foot Hinge	押エヒンジ	1
3	004351	Screw (9/64-40×7)	止ネジ	1
4	2107279	Presser Foot (Lower)	押エ(下)	1
5-1	2107203	Presser Foot Chain Shield	空糸押エ	1
5-2	0022416	" " (with MT2)	" "	1
6	004237	Screw (3/32-56×1.7)	止ネジ	1
7-1	0036822	Presser Foot Stitch Tongue (04)	爪	1
7-2	0034257	" " (05)	" "	1
8	0021005	Presser Foot Hinge Spring	押エヒンジバネ	1
9	005036	Screw (1/8-44×5.6)	止ネジ	1
10	0038805	Tape Guide (Right)	テープガイド(右)	1
11	0038806	Tape Guide (Left)	テープガイド(左)	1
12	004236	Screw (3/32-56×4.2)	止ネジ	1
13-1	2108010	Stitch Plate (04)	針板	1
13-2	2108026	" (05)	" "	1
14	2109005	Differential Feed Dog (04, 05)	前送り	1
15	2109052	Auxiliary Feed Dog	小送り	1
16	0021301	Presser Foot Stay	押エ固定片	1
17	0024129	Tape Guide (Lower)	テープガイド(下)	1
18	110013	Screw (M4-0.7×8)	止ネジ	2
19	100001	Nut	ナット	2
20	0033738	Tape Guide Tube	テープ支エ	2
21	2100638	Upper Looper Bar Crank Arm, C. Set	上ルーパクランク(組)	1
22	2100226	Upper Looper Bar Guide Bushing	ルーパ案内メタル	1
23	2100227	Upper Looper Bar Guide Cover	ルーパ案内蓋	1
24	130001	Screw (M2.5-0.45×6)	止ネジ	1
25	110071	Screw (M2.5-0.45×6)	止ネジ	1
26	2100639	Upper Looper Bar Guide, C. Set	ルーパ案内(組)	1
27	2100221	Upper Looper Bar Crank Arm	上ルーパクランク	1
28	300008	Washer	ワッシャ	1
29	140004	Screw (M6-1×14)	止ネジ	1
30	2100176	Upper Looper Bar Crank Arm Pin	上ルーパクランクピン	1
31	160002	Screw (M4-0.7×5)	止ネジ	1
32	310048	Oil Wick	油芯	1
33	2100643	Upper Looper Bar Unit	ルーパ棒(組)	1
34	330011	Seal Plug	詰線	1
35	2100640	Upper Looper Bar Guide	ルーパ案内	1
36	310049	Oiling Felt	フェルト	1
37	0020538	O-ring (P7)	Oリング	1

AZ6098H

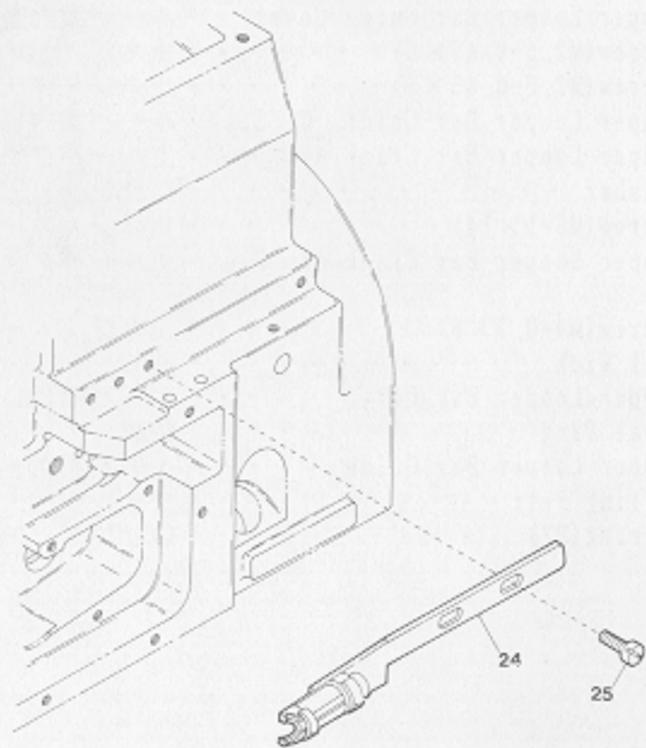
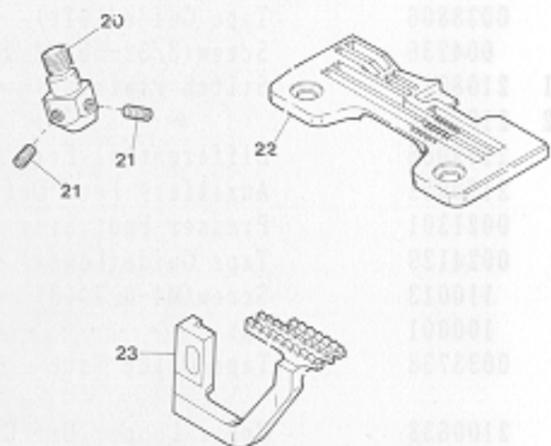
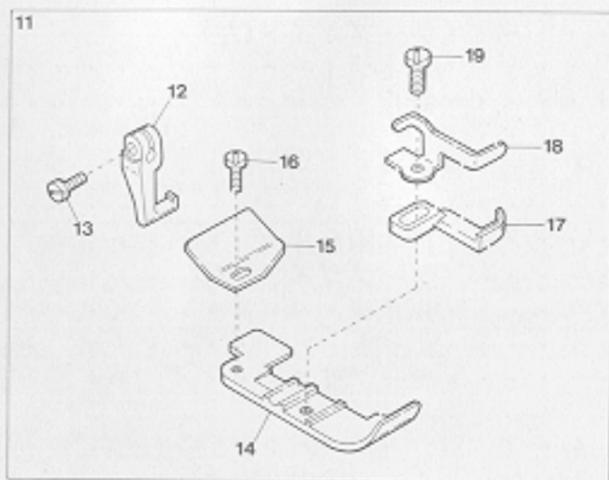
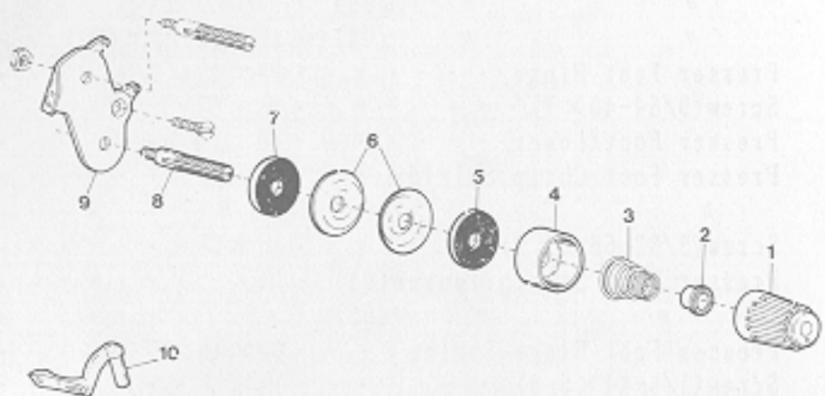

AZ6098H-Y EXCLUSIVE PARTS

サブモデル専用部品

Ref. No.	Parts No.	Description	品名	Amt. Req.
1	0024084	Thread Tension Spring Cap	糸調子バネキャップ(上)	1
2	0024083	Tension Spring Bushing	糸調子ナット回り止メ	1
3	0032971	Needle Thread Tension Spring	針糸調子バネ	1
4	0020118	Thread Tension Spring Retainer	糸調子バネキャップ(下)	1
5	000178	Felt	フェルト	1
6	0031111	Tension Disc	糸調子皿	1
7	000177	Felt	フェルト	2
8	004265	Tension Post (Short)	糸調子棒(短)	1
9	2100074	Tension Disc Eyelet (Large)	調子台糸道(大)	1
10	2109322	Upper Loper (for Needle Size #9~14)	上ルーパ(針番手 #9~14用)	1
11	2107397	Presser Foot, Complete Set (Y5)	押エ(組)	1
12	0024100	Presser Foot Hinge	押エヒンジ	1
13	004351	Screw (9/64-40x7)	止ネジ	1
14	2107278	Presser Foot (Lower)	押エ	1
15	0034535	Presser Foot Chain Shield	空糸押エ	1
16	004237	Screw (3/32-56x2.6)	止ネジ	1
17	2107229	Presser Foot Stitch Tongue (Y5)	爪	1
18	2107198	Presser Foot Hinge Spring	押エヒンジバネ	1
19	005036	Screw (1/8-44x5.6)	止ネジ	2
20	2109130	Needle Clamp (Y)	針止メ	1
21	003637	Screw (1/8-44x2.5)	止ネジ	2
22	2108118	Stitch Plate (Y5)	針板	1
23	2109068	Differential Feed Dog	前送り	1
24	2100478	Folder	定規	1
25	110047	Screw (M4-0.7x10)	止ネジ	2



"K2" DEVICE (1)

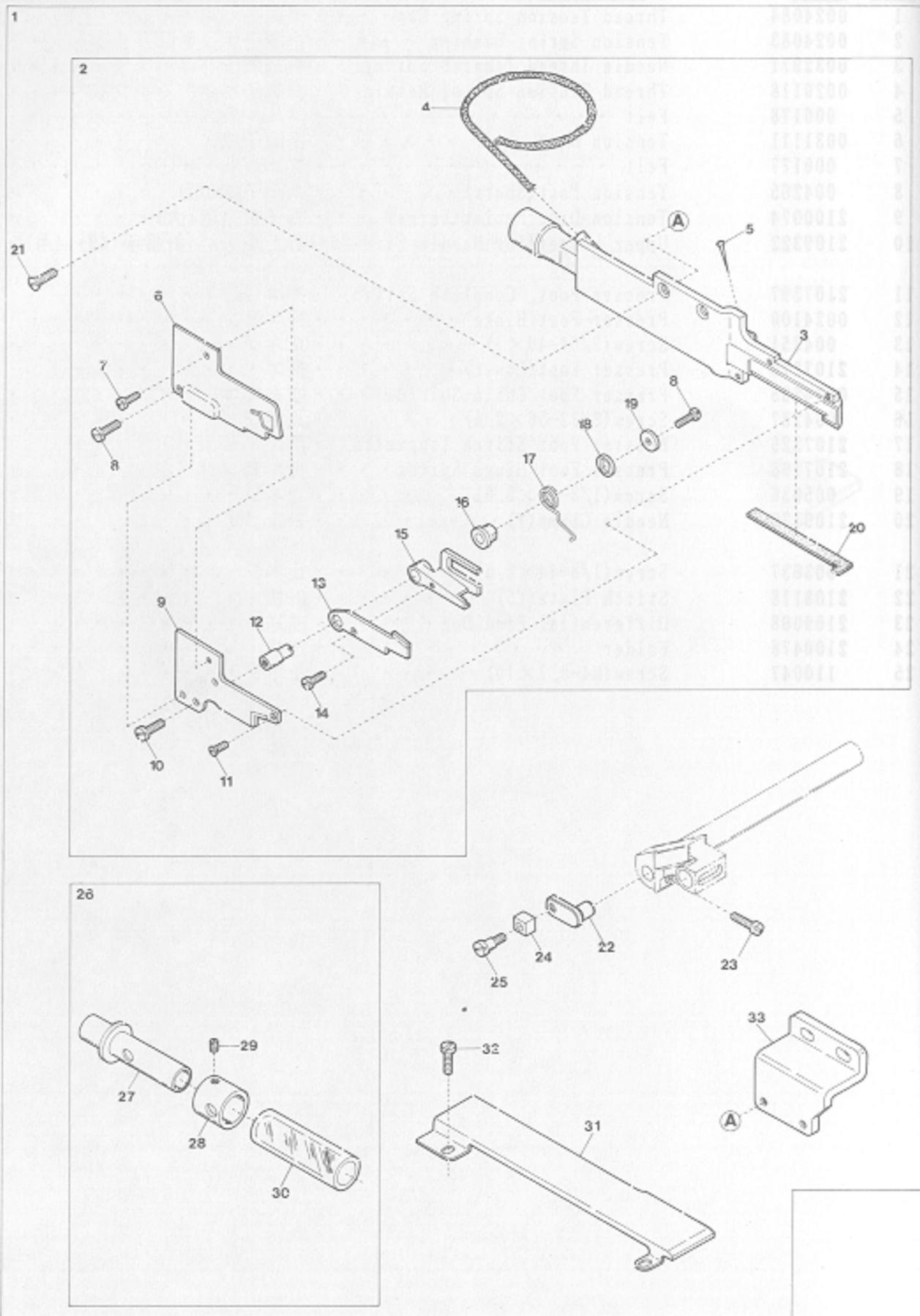

"K2" DEVICE (1)

Ref. No.	Parts No.	Description	品名	Amt. Req.
1	2109917	"K2" Device, Complete Set	"K2"装置(組)	1
2	2111050	Suction Pipe, Complete Set	吸込管(組)	1
3	2111051	Suction Pipe	吸込管本体	1
4	310017	Oil Wick	油芯	1
5	000755	Oil Wick Pin	止メピン	1
6	2111063	Suction Pipe Cover	吸込管カバー	1
7	004237	Screw (3/32-56×1.7)	止ネジ	1
8	004404	Screw (3/32-56×5.1)	止ネジ	2
9	2111055	Upper Trimming Knife	上刃	1
10	004131	Screw (1/8-44×6)	止ネジ	1
11	004139	Screw (3/32-56×3)	止ネジ	2
12	2111059	Lower Trimming Knife Holder Pin	下刃支持ピン	1
13	2111056	Lower Trimming Knife	下刃	1
14	004236	Screw (3/32-56×4.2)	止ネジ	1
15	2111057	Lower Trimming Knife Driving Plate	下刃駆動板	1
16	2111062	Spring Sleeve	下刃バネスリーブ	1
17	2111061	Lower Trimming Knife Pushing Spring	下刃圧着バネ	1
18	2111066	Spring Protect Washer	下刃バネワッシャ	1
19	2111060	Washer	ワッシャ	1
20	2111067	Air Shield Rubber	隙間防止ゴム	1
21	007623	Screw (9/64-40×5.3)	止ネジ	2
22	2111058	Lower Trimming Knife Guide Support	下刃ガイド取付台	1
23	110068	Screw (M4-0.7×8)	止ネジ	1
24	2101011	Lower Trimming Knife Guide	下刃ガイド	1
25	270001	Screw (1/8-44×3)	止ネジ	1
26	0021451	Suction Power Control Tube, C. Set	吸引力調整管(組)	1
27	0021457	Suction Power Control Tube (Inner)	吸引力調整管	1
28	0021456	Suction Power Control Tube	吸引力調整管	1
29	001892	Screw (1/8-44×2.9)	止ネジ	1
30	0021450	Nylon Hose	吸引チューブ	1
31	2101059	Cloth Plate Spacer	クロスプレートスペーサ	1
32	110042	Screw (M3.5-0.6×4)	止ネジ	2
33	2101058	Suction Pipe Support	吸込管取付台	1

"K2"装置(1)

Amt.

Req.

3-1	2107359	Presser Foot (Lower) (04)		
3-1	2107286	Presser Foot (Upper) (04)		
3-1	2107039	Presser Foot (04)		
3-1	2107243	Presser Foot Stitch Tongue (04)		
3-1	2107042	Presser Foot (04)		
3-1	0021805	Presser Foot Hinge Spring		
3-1	2107372	Presser Foot, Complete Set (03)		
3-1	2107373	Presser Foot, Complete Set (04)		
3-1	2107324	Presser Foot Stitch Tongue (03)		
3-1	2107223	Presser Foot (04)		

"K2" DEVICE (2)

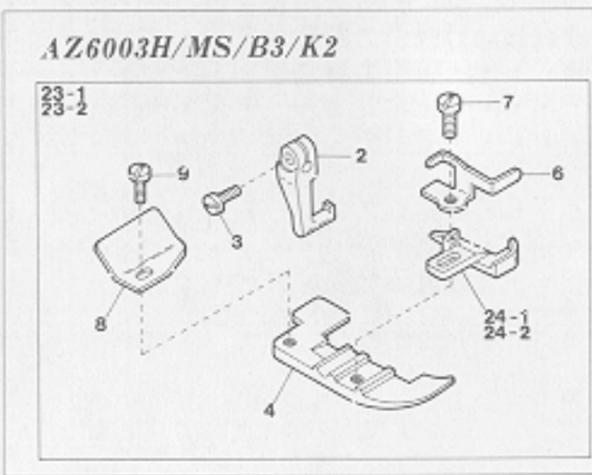
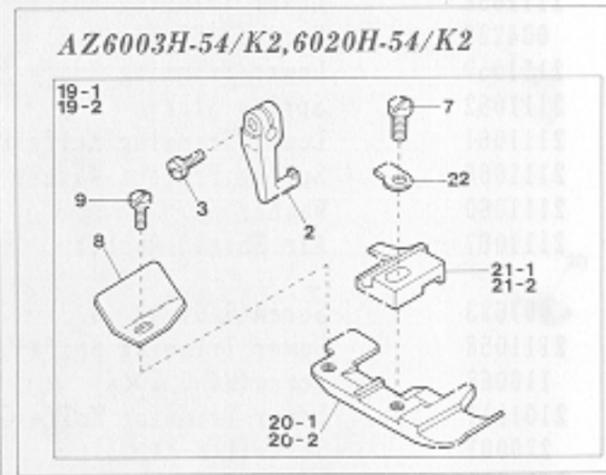
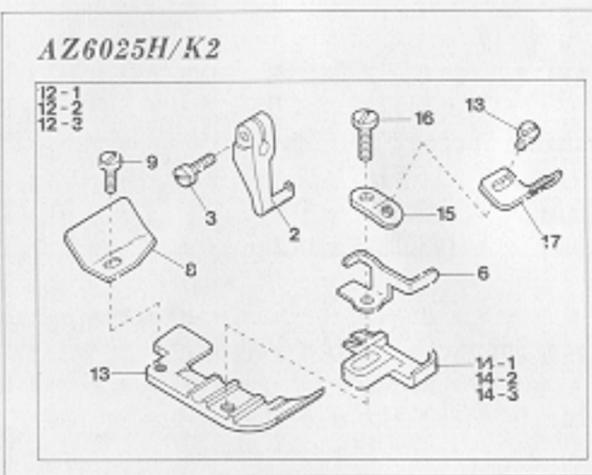
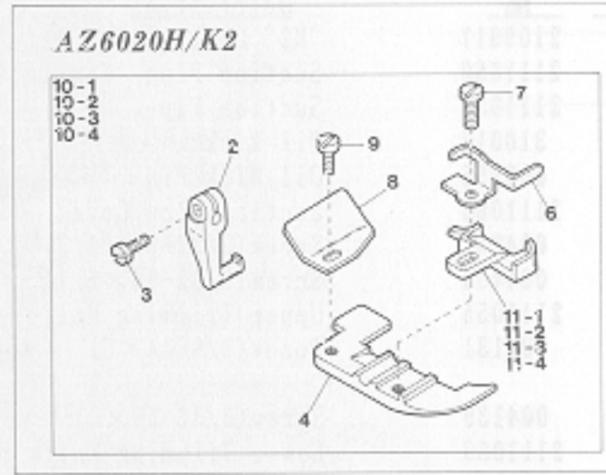
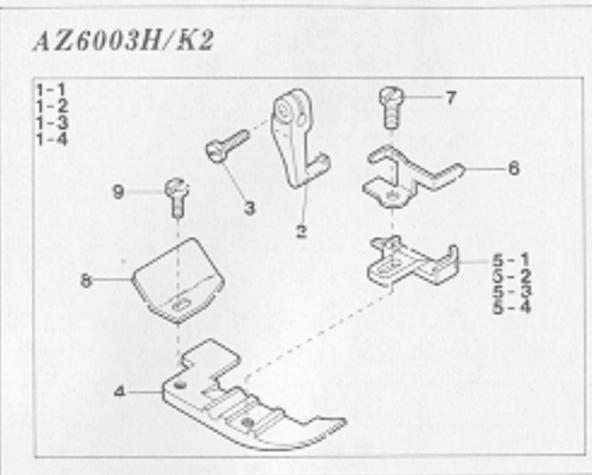

"K2" DEVICE (2)

Ref. No	Parts No	Description	品名	Amt. Req.
1-1	2107335	Presser Foot, Complete Set (03)	押エ(組)	1
1-2	2107336	" " " " (04)	"	1
1-3	2107337	" " " " (05)	"	1
1-4	2107338	" " " " (06)	"	1
2	0024100	Presser Foot Hinge	押エヒンジ	1
3	004351	Screw(9/64-40×7)	止ネジ	1
4	2107280	Presser Foot(Lower)	押エ(下)	1
5-1	2107220	Presser Foot Stitch Tongue(03)	爪	1
5-2	2107221	" " " " (04)	"	1
5-3	2107222	" " " " (05)	"	1
5-4	2107223	" " " " (06)	"	1
6	2107162	Presser Foot Hinge Spring	押エヒンジバネ	1
7	005036	Screw(1/8-44×5.6)	止ネジ	1
8	2107219	Presser Foot Chain Shield	空糸押エ	1
9	004237	Screw(3/32-56×2.6)	止ネジ	1
10-1	2107339	Presser Foot, Complete Set (Y5)	押エ(組)	1
10-2	2107340	" " " " (Y6)	"	1
10-3	2107341	" " " " (X4)	"	1
10-4	2107342	" " " " (X5)	"	1
11-1	2107230	Presser Foot Stitch Tongue(Y5)	爪	1
11-2	2107231	" " " " (Y6)	"	1
11-3	2107232	" " " " (X4)	"	1
11-4	2107233	" " " " (X5)	"	1
12-1	2107363	Presser Foot, Complete Set(Y5)	押エ(組)	1
12-2	2107364	Lower " " " " (Y6)	"	1
12-3	2107361	Screw " " " " (X4)	"	1
13	2107290	Presser Foot(Lower)	押エ(下)	1
14-1	2107240	Presser Foot Stitch Tongue(Y5)	爪	1
14-2	2107241	" " " " (Y6)	"	1
14-3	2107238	Screw " " " " (X4)	"	1
15	2107173	Tape Guide Support	テープガイド取付板	1
16	210005	Screw(1/8-44×7.1)	止ネジ	1
17	2107174	Presser Foot Tape Guide	押エテープガイド	1
18	001228	Screw(3/32-56×3.2)	止ネジ	1
19-1	2107358	Presser Foot, Complete Set(04)	押エ(組)	1
19-2	2107359	" " " " (Y6)	"	1
20-1	2107286	Presser Foot(Lower) (04)	押エ(下)	1
20-2	2107039	" " " " (Y6)	"	1
21-1	2107243	Presser Foot Stitch Tongue(04)	爪	1
21-2	2107042	" " " " (Y6)	"	1
22	0021005	Presser Foot Hinge Spring	押エヒンジバネ	1
23-1	2107372	Presser Foot, Complete Set(03)	押エ(組)	1
23-2	2107373	" " " " (04)	"	1
24-1	2107224	Presser Foot Stitch Tongue(03)	爪	1
24-2	2107225	" " " " (04)	"	1

"K2"装置(2)

Amt. Req.

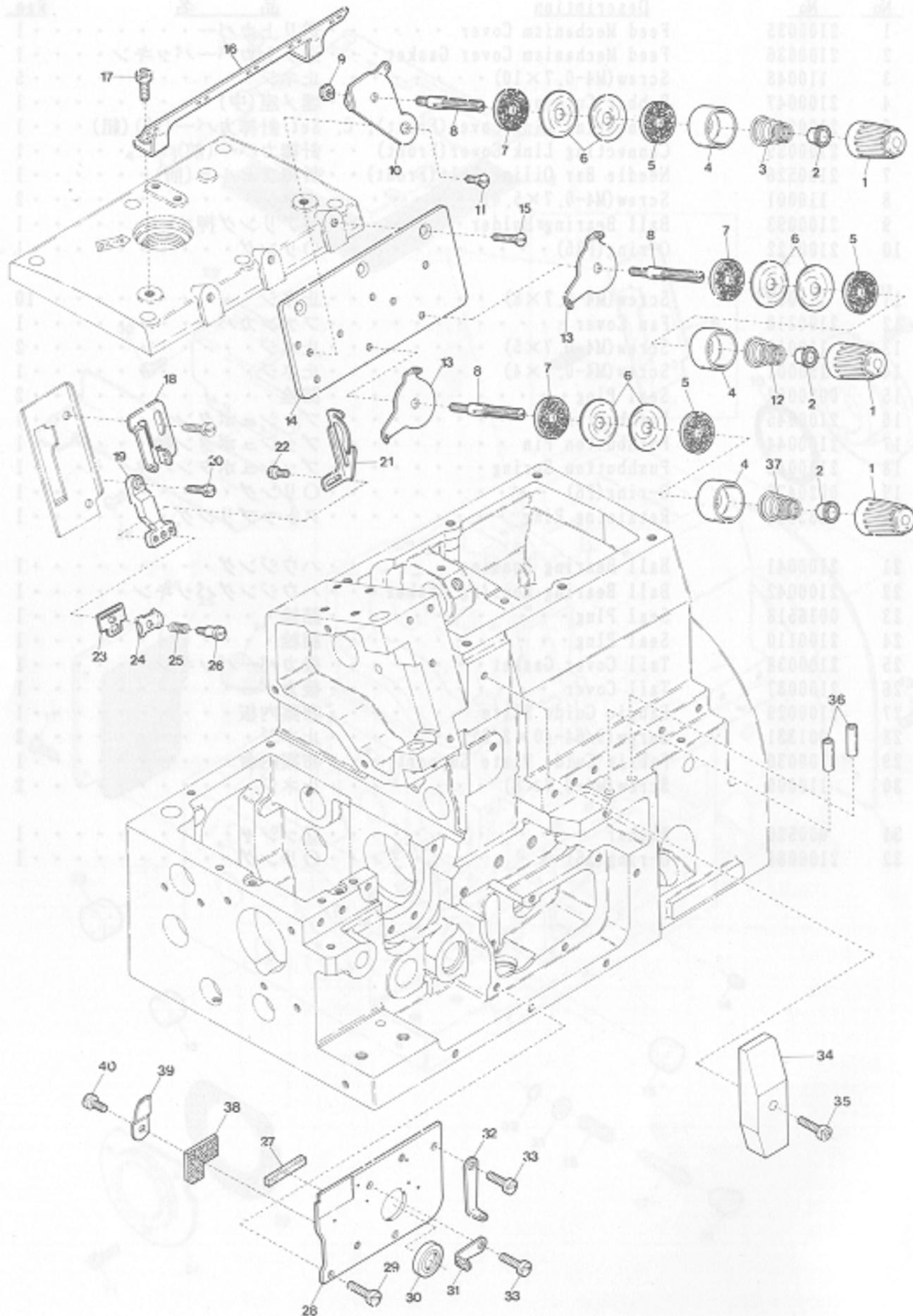

MISCELLANEOUS THREAD EYELETS

糸道関係

4

Amt.

Req.

Ref. No	Parts No	Description	品名	Amt. Req.
1	0024084	Thread Tension Spring Cap	糸調子バネキャップ(上)	3
2	0024083	Tension Spring Bushing	糸調子ナット回り止め	3
3	0024156	Needle Thread Tension Spring	針糸調子バネ	1
4	0020118	Thread Tension Spring Retainer	糸調子バネキャップ(下)	3
5	000178	Felt	フェルト	3
6	0031111	Tension Disc	糸調子皿	6
7	000177	Felt	フェルト	3
8	004265	Tension Post (Short)	糸調子棒(短)	3
9	000340	Nut	ナット	1
10	2100073	Tension Disc Eyelet for Needle Thread	針糸調子台糸道	1
11	001396	Screw(11/64-40×6.5)	止ネジ	1
12	0024157	Lower Loper Thread Tension Spring	下ルーパ糸調子バネ	1
13	0020101	Tension Disc Eyelet for Loper Thread	ルーパ糸調子台糸道	2
14	2100062	Tension Disc Eyelet Support	調子台糸道取付板	1
15	130007	Screw(M4-0.7×10)	止ネジ	3
16	2100063	Thread Guide Plate	糸案内板	1
17	110013	Screw(M4-0.7×8)	止ネジ	2
18	2100520	Needle Thread Eyelet(Large)	針糸道(大)	1
19	2100071	Needle Bar Thread Retainer Bracket	小調子台	1
20	110029	Screw(M3.5-0.6×6)	止ネジ	1
21	2100519	Needle Thread Pull-off	針糸繰り	1
22	001228	Screw(3/32-56×3.2)	止ネジ	2
23	2100592	Thread Retainer Plate Support	小調子板	1
24	0032425	Thread Retainer Plate	小調子皿	1
25	0020131	Thread Retainer Spring	小調子皿バネ	1
26	001095	Screw(1/8-44×8.5)	止ネジ	1
27	2100229	Looper Holder Cover Spacer(Rubber)	ルーパ台カバースペース	1
28	2100060	Looper Holder Cover	ルーパ台カバー	1
29	110009	Screw(M4-0.7×8)	止ネジ	2
30	0093303	Looper Driving Shaft Oil Seal	ルーパ軸オイルシール	1
31	2100521	Looper Thread Eyelet	ルーパ糸道	1
32	2100065	Lower Loper Thread Eyelet	下ルーパ糸道	1
33	110035	Screw(M4-0.7×10)	止ネジ	2
34	2100606	Dust-proof Cover	防塵カバー	1
35	110012	Screw(M4-0.7×8)	止ネジ	1
36	0022215	Looper Thread Pipe	糸道パイプ	2
37	0032952	Upper Loper Thread Tension Spring	上ルーパ糸調子バネ	1
38	2100586	Looper Holder Cover Felt	ルーパ台カバーフェルト	1
39	2100524	Felt Clamp	フェルト押エ	1
40	110030	Screw(M3-0.5×2.6)	止ネジ	1

"KR2" DEVICE (1)

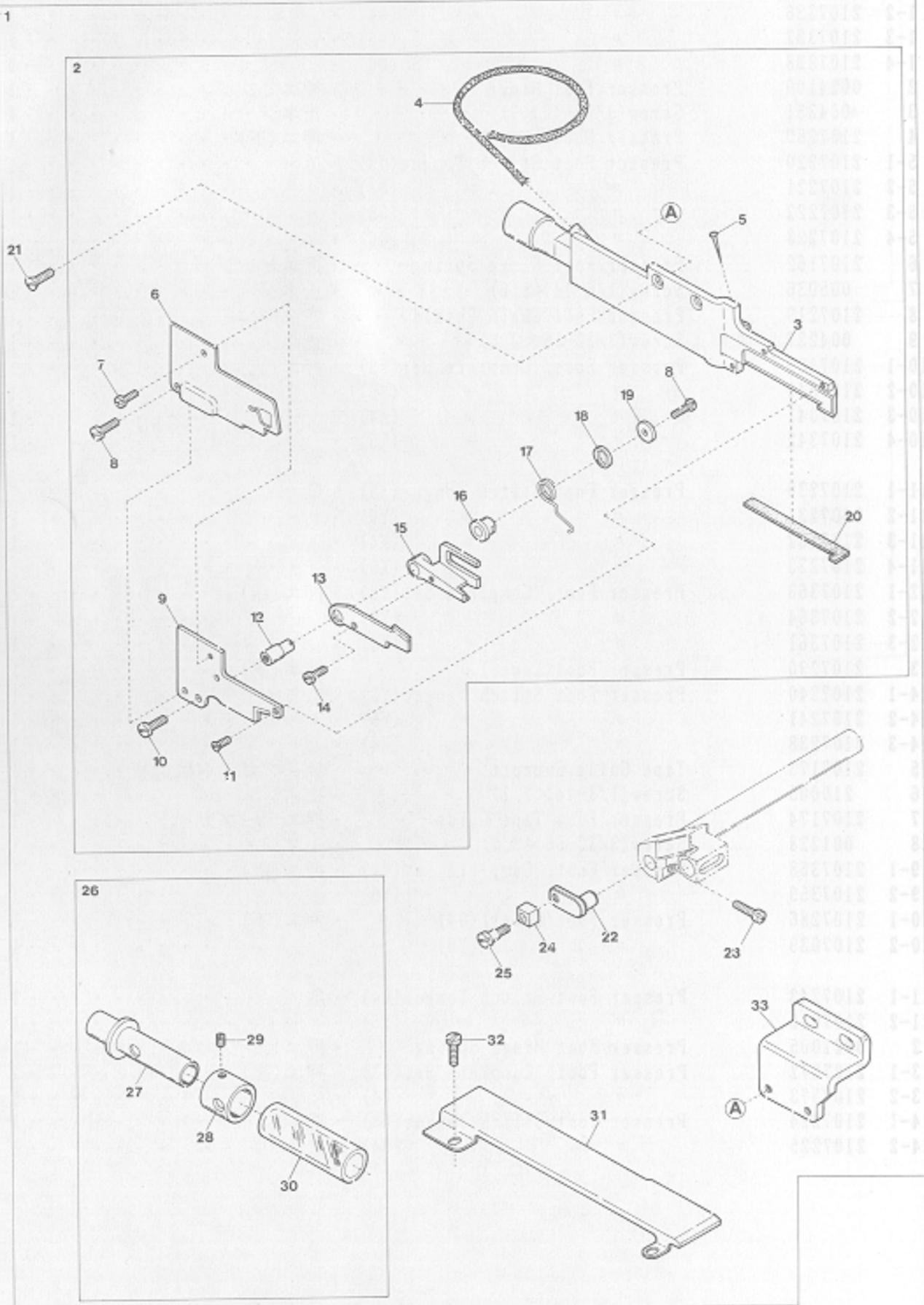

"KR2" DEVICE(1)

Ref. No.	Parts No.	Description	品名	Amt. Req.
1	2109917	"K2" Device, Complete Set	"K2"装置(組)	1
2	2111050	Suction Pipe, Complete Set	吸込管(組)	1
3	2111051	Suction Pipe	吸込管本体	1
4	310017	Oil Wick	油芯	1
5	000755	Oil Wick Pin	止メピン	1
6	2111063	Suction Pipe Cover	吸込管カバー	1
7	004237	Screw(3/32-56×1.7)	止ネジ	1
8	004404	Screw(3/32-56×5.1)	止ネジ	2
9	2111055	Upper Trimming Knife	上刃	1
10	004131	Screw(1/8-44×6)	止ネジ	1
11	004139	Screw(3/32-56×3)	止ネジ	2
12	2111059	Lower Trimming Knife Holder Pin	下刃支持ピン	1
13	2111056	Lower Trimming Knife	下刃	1
14	004236	Screw(3/32-56×4.2)	止ネジ	1
15	2111057	Lower Trimming Knife Driving Plate	下刃駆動板	1
16	2111062	Spring Sleeve	下刃バネスリーブ	1
17	2111061	Lower Trimming Knife Pushing Spring	下刃圧着バネ	1
18	2111066	Spring Protect Washer	下刃バネワッシャ	1
19	2111060	Washer	ワッシャ	1
20	2111067	Air Shield Rubber	隙間防止ゴム	1
21	007623	Screw(9/64-40×5.3)	止ネジ	2
22	2111058	Lower Trimming Knife Guide Support	下刃ガイド取付台	1
23	110068	Screw(M4-0.7×8)	止ネジ	1
24	2101011	Lower Trimming Knife Guide	下刃ガイド	1
25	270001	Screw(1/8-44×3)	止ネジ	1
26	0021451	Suction Power Control Tube, C. Set	吸引力調整管(組)	1
27	0021457	Suction Power Control Tube(Inner)	吸引力調整台	1
28	0021456	Suction Power Control Tube	吸引力調整管	1
29	001892	Screw(1/8-44×2.9)	止ネジ	1
30	0021450	Nylon Hose	吸引チューブ	1
31	2101059	Cloth Plate Spacer	クロスプレートスペーサ	1
32	110042	Screw(M3.5-0.6×4)	止ネジ	2
33	2101058	Suction Pipe Support	吸込管取付台	1

"KR2"装置(1)

40

Amt. Req.

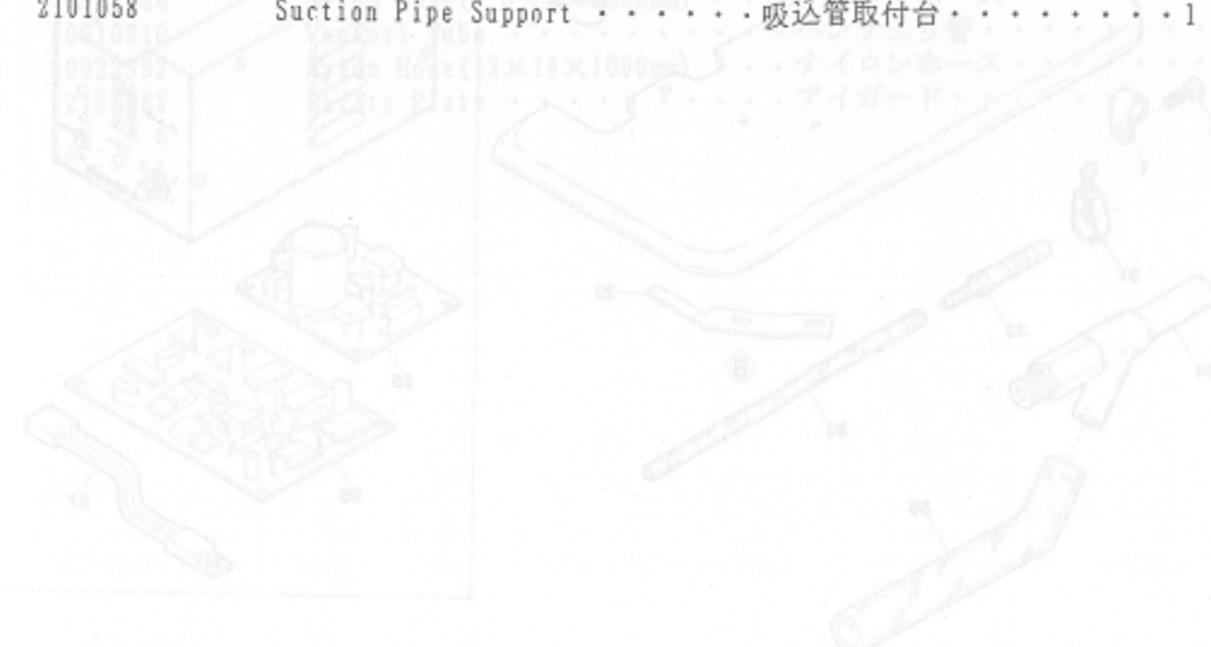

"KR2" DEVICE(2)

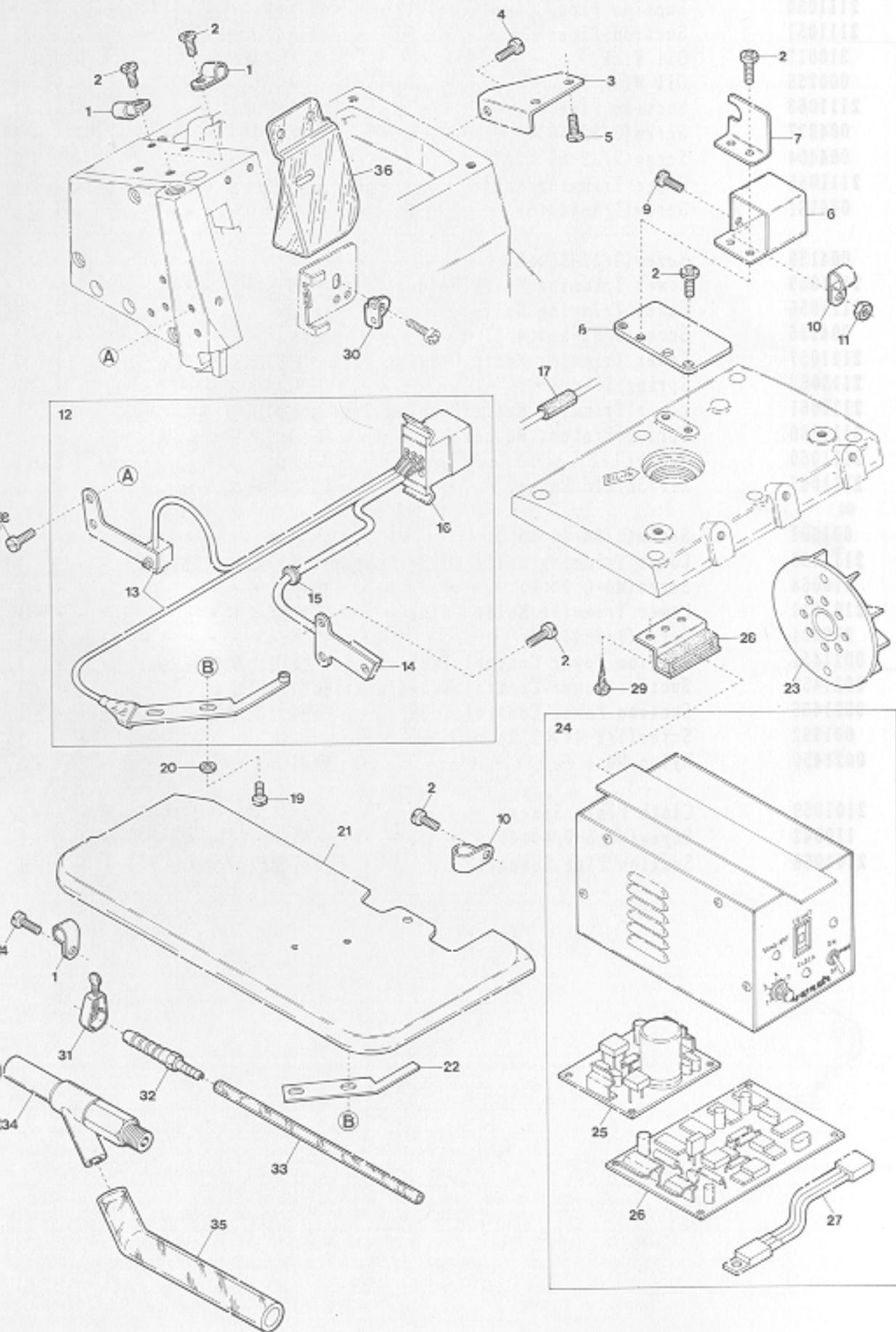

"KR2" DEVICE(2)

Ref. No.	Parts No.	Description	Amt. Req.
1	0094491	Cord Clamp(φ 3.4-2N)	3
2	110038	Screw(M4-0.7×8)	9
3	2101138	Solenoid Stay	1
4	110012	Screw(M4-0.7×5)	2
5	004358	Screw(9/64-40×5.6)	1
6	0011840	Connector Case	1
7	0011841	Connector Case Lid	1
8	2101452	Connector Case Support	1
9	110048	Screw(M4-0.7×10)	1
10	0036133	Cord Clamp(φ 8.4-5N)	2
11	100001	Nut	1
12	1200011	Rotation & Fabric Detector Switch, C. Set	1
13	1200009	Fabric Detector Switch Unit	1
14	1200008	Rotation Detector Unit	1
15	0035722	Cord Bushing	1
16	1070001	Connector(9P)	1
17	2101124	Cord Bushing	1
18	110001	Screw(M4-0.7×5.4)	2
19	110102	Screw(M2.5-0.45×5)	2
20	300007	Washer	2
21	2101113	Cloth Plate	1
22	0011995	Insulating Plate	1
23	2101043	Oil Cooling Fan Magnet Unit	1
24	0011323	Control Box, Complete Set	1
25	0011324	Power Board	1
26	0011970	Control Board	1
27	0011974	Voltage Regulator	1
28	0011709	Control Box Stay	2
29	006910	Wood Screw(φ 6.8×26)	4
30	2101116	Tension Disc Auxiliary Eyelet	1
31	0033939	Hose Band(1/4 inch)	1
32	0033932	Joint	1
33	0022404	Nylon Hose(3.8×6×1000mm)	1
34	0010310	Venturi Tube	1
35	0022392	Nylon Hose(12×18×1000mm)	1
36	2100082	Safety Plate	1

"KR2" 装置(2)

品名	Amt. Req.
コードクランプ	3
止ネジ	9
ソレノイド支エ	1
止ネジ	2
止ネジ	1
コネクタケース	1
コネクタケース蓋	1
コネクタケース取付板	1
止ネジ	1
コードクランプ	2
ナット	1
ホMIC・焼スイッチ(組)	1
光電スイッチ(組)	1
ホールIC(組)	1
コードブッシュ	1
コネクタ	1
コードブッシュ	1
止ネジ	2
止ネジ	2
ワッシャ	2
クロスプレート	1
絶縁板	1
ファンマグネット(組)	1
制御装置(組)	1
電源基板	1
制御基板	1
定電圧IC	1
制御ボックスステイ	2
木ネジ	4
調子台補助糸道	1
ホースバンド	1
ジョイント	1
ナイロンホース	1
ベンチュリ管	1
ナイロンホース	1
アイガード	1

“KR2” DEVICE (3)

AZ6003H/KR2

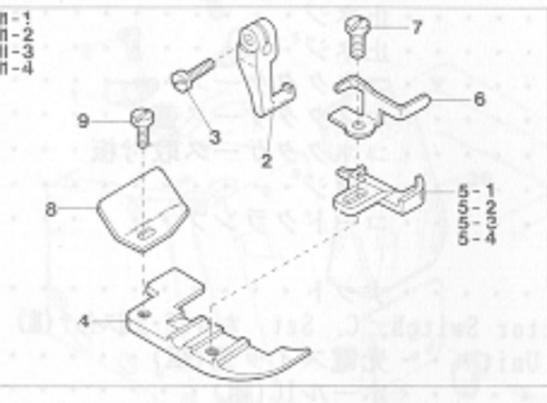

AZ6020H/KR2

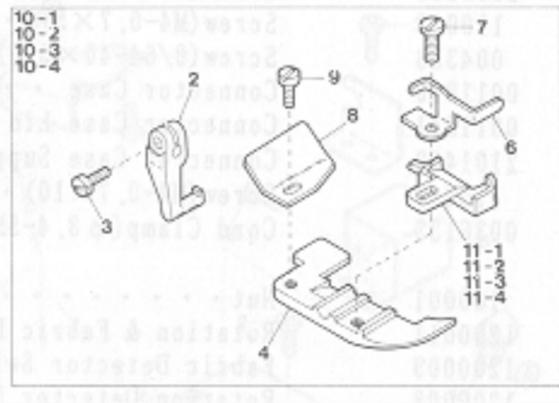

“KR2” DEVICE(3)

Ref. No	Parts No	Description
1-1	2107335	Presser Foot, Complete Set(03)
1-2	2107336	Thrd " Tension Spr " (04)
1-3	2107337	Thrd " Tension Spr " (05)
1-4	2107338	Thrd " Tension Spr " (06)
2	0024100	Presser Foot Hinge
3	004351	Screw(9/64-40×7)
4	2107280	Presser Foot(Lower)
5-1	2107220	Presser Foot Stitch Tongue(03)
5-2	2107221	" " " (04)
5-3	2107222	" " " (05)
5-4	2107223	" " " (06)
6	2107162	Presser Foot Hinge Spring
7	005036	Screw(1/8-44×5.6)
8	2107219	Presser Foot Chain Shield
9	004237	Screw(3/32-56×2.6)
10-1	2107339	Presser Foot, Complete Set(Y5)
10-2	2107340	Sol " " " (Y6)
10-3	2107341	Nut " " " (X4)
10-4	2107342	Sol " Spring " " (X5)
11-1	2107230	Presser Foot Stitch Tongue(Y5)
11-2	2107231	" " " (Y6)
11-3	2107232	Nut " " " (X4)
11-4	2107233	Thrd " " " " (X5)

“KR2”装置(3)

Ref. No	Parts No	Description	品名	Amt. Req.
1-1	2107335	Presser Foot, Complete Set(03)	押エ(組)	1
1-2	2107336	Thrd " Tension Spr " (04)	"	1
1-3	2107337	Thrd " Tension Spr " (05)	"	1
1-4	2107338	Thrd " Tension Spr " (06)	"	1
2	0024100	Presser Foot Hinge	押エヒンジ	1
3	004351	Screw(9/64-40×7)	止ネジ	1
4	2107280	Presser Foot(Lower)	押エ(下)	1
5-1	2107220	Presser Foot Stitch Tongue(03)	爪	1
5-2	2107221	" " " (04)	"	1
5-3	2107222	" " " (05)	"	1
5-4	2107223	" " " (06)	"	1
6	2107162	Presser Foot Hinge Spring	押エヒンジバネ	1
7	005036	Screw(1/8-44×5.6)	止ネジ	1
8	2107219	Presser Foot Chain Shield	空糸押エ	1
9	004237	Screw(3/32-56×2.6)	止ネジ	1
10-1	2107339	Presser Foot, Complete Set(Y5)	押エ(組)	1
10-2	2107340	Sol " " " (Y6)	"	1
10-3	2107341	Nut " " " (X4)	"	1
10-4	2107342	Sol " Spring " " (X5)	"	1
11-1	2107230	Presser Foot Stitch Tongue(Y5)	爪	1
11-2	2107231	" " " (Y6)	"	1
11-3	2107232	Nut " " " (X4)	"	1
11-4	2107233	Thrd " " " " (X5)	"	1

Note: (G) Green colored, (W) White colored.
 (注) (G)緑色, (W)白色。

"KR2"DEVICE(4) for AZ6003H

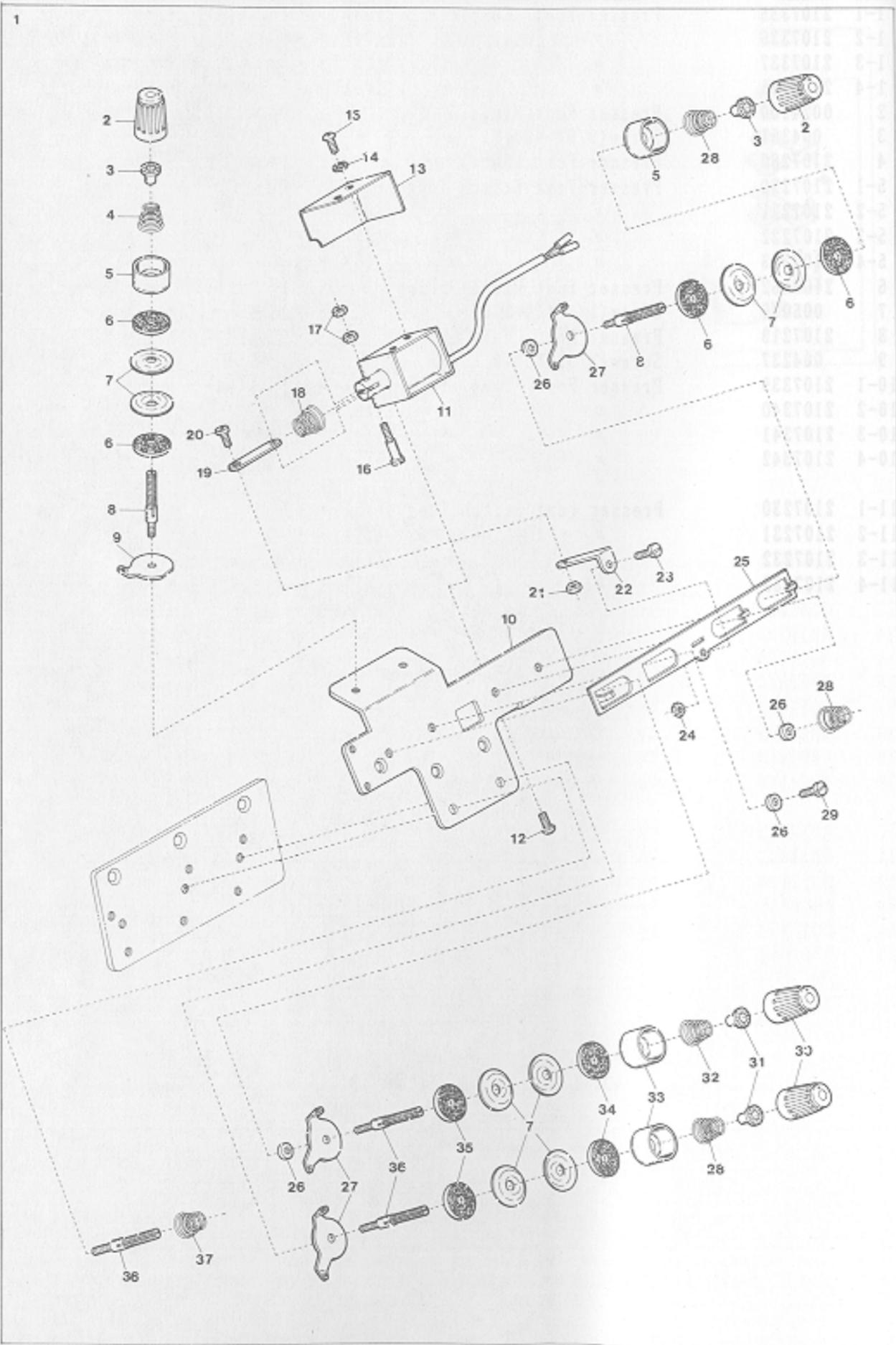

"KR2" DEVICE(4) for AZ6003H

"KR2"装置(4)

Ref. No.	Parts No.	Description	品名	Amt. Req.
1	2101056	Thread Tension Release, C.Set	糸緩メ装置(組)	1
2	0033806	Thread Tension Spring Cap(G)	糸調子バネキャップ(上)(緑)	3
3	0033890	Thread Tension Spring Bushing	糸調子ナット回り止メ	3
4	0020103	Thread Tension Spring	糸調子バネ	1
5	0033807	Thread Tension Spring Retainer(G)	糸調子バネキャップ(下)(緑)	3
6	000286	Felt(G)	フェルト(緑)	6
7	0031111	Tension Disc	糸調子皿	12
8	007904	Tension Post(Short)	糸調子棒(短)	3
9	0036853	Tension Disc Eyelet	調子台糸道	1
10	0023185	Thread Tension Release Supporting Board	糸緩メ台	1
11	0011839	Thread Tension Release Solenoid	ソレノイド	1
12	009994	Screw(M3-0.5×8)	止ネジ	2
13	0023189	Solenoid Cover	ソレノイドカバー	1
14	000014	Washer	ワッシャ	2
15	009995	Screw(M3-0.5×5)	止ネジ	2
16	005128	Solenoid Connecting Pin	ソレノイド連結ピン	1
17	000021	Nut	ナット	2
18	0032971	Solenoid Spring	ソレノイドバネ	1
19	0023187	Thread Tension Release Link	糸緩メリンク	1
20	006092	Screw(1/8-44×4)	止ネジ	1
21	000230	Nut	ナット	1
22	2101148	Thread Tension Release Plate Guide	糸緩メ板ガイド	1
23	009746	Screw(M4-0.7×8)	止ネジ	1
24	000015	Nut	ナット	1
25	2101329	Thread Tension Release Plate	糸緩メ板	1
26	000496	Spacer	スペーサ	4
27	0020101	Tension Disc Eyelet	調子台糸道	5
28	0024157	Thread Tension Spring	糸調子バネ	3
29	009853	Screw(11/64-40×6.5)	止ネジ	1
30	0024084	Thread Tension Spring Cap(W)	糸調子バネキャップ(上)(白)	3
31	0024083	Thread Tension Spring Bushing	糸調子ナット回り止メ	3
32	0024156	Thread Tension Spring	糸調子バネ	1
33	0020118	Thread Tension Spring Retainer(W)	糸調子バネキャップ(下)(白)	3
34	000178	Felt(W)(2.5mm)	フェルト(白)	3
35	000177	Felt(W)(1.0mm)	フェルト(白)	3
36	007903	Tension Post(Long)	糸調子棒(長)	3
37	0032952	Thread Tension Spring	糸調子バネ	1

Note:(G).....Green colored, (W).....White colored.
 (注) (G)は緑色、(W)は白色を表わします。

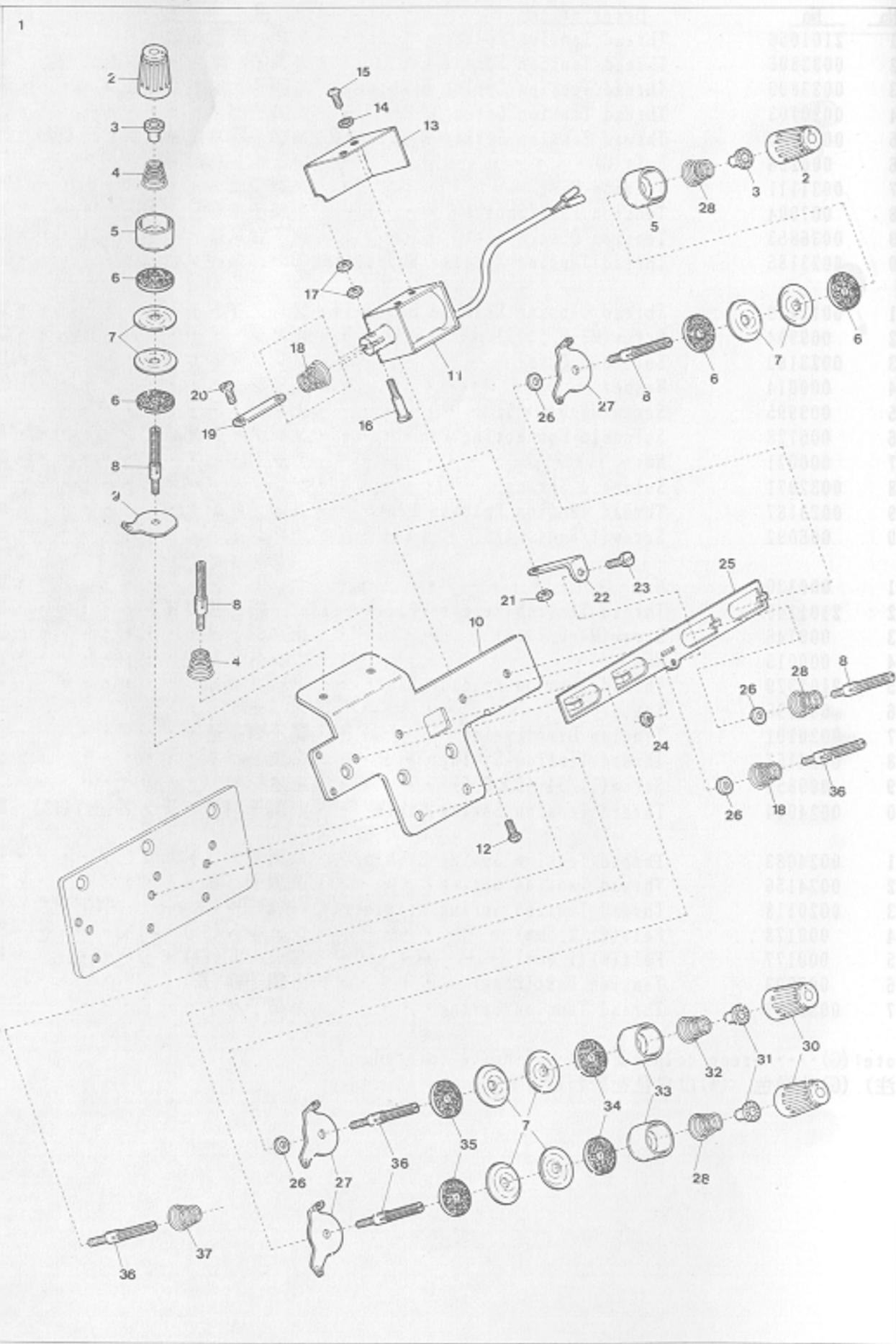

Ref. No.	Parts No.	Description	品名	Amt.	Req.
1	2101057	Thread Tension Release, C. Set	糸緩メ装置(組)	1	1
2	0033806	Thread Tension Spring Cap(G)	糸調子バネキャップ(上)(緑)	4	4
3	0033890	Thread Tension Spring Bushing	糸調子ナット回り止メ	4	4
4	0020103	Thread Tension Spring	糸調子バネ	2	2
5	0033807	Thread Tension Spring Retainer(G)	糸調子バネキャップ(下)(緑)	4	4
6	000286	Felt(G)	フェルト(緑)	8	8
7	0031111	Tension Disc	糸調子皿	16	16
8	007904	Tension Post(Short)	糸調子棒(短)	4	4
9	0036853	Tension Disc Eyelet	調子台糸道	2	2
10	0023185	Thread Tension Release Supporting Board	糸緩メ台	1	1
11	0011839	Thread Tension Release Solenoid	ソレノイド	1	1
12	009994	Screw(M3-0.5×8)	止ネジ	2	2
13	0023189	Solenoid Cover	ソレノイドカバー	1	1
14	000014	Washer	ワッシャ	2	2
15	009995	Screw(M3-0.5×5)	止ネジ	2	2
16	005128	Solenoid Connecting Pin	ソレノイド連結ピン	1	1
17	000021	Nut	ナット	2	2
18	0032971	Solenoid Spring & Thread Tension Spring	ソレノイドバネ、糸調子バネ	2	2
19	0023187	Thread Tension Release Link	糸緩メリンク	1	1
20	006092	Screw(1/8-44×4)	止ネジ	1	1
21	000330	Nut	ナット	1	1
22	2101148	Thread Tension Release Guide Plate	糸緩メ板ガイド	1	1
23	009746	Screw(M4-0.7×8)	止ネジ	1	1
24	000015	Nut	ナット	1	1
25	2101330	Thread Tension Release Plate	糸緩メ板	1	1
26	000496	Spacer	スペーサ	4	4
27	0020101	Tension Disc Eyelet	調子台糸道	6	6
28	0024157	Thread Tension Spring	糸調子バネ	3	3
29					
30	0024084	Thread Tension Spring Cap(W)	糸調子バネキャップ(上)(白)	4	4
31	0024083	Thread Tension Spring Bushing	糸調子ナット回り止メ	4	4
32	0024156	Thread Tension Spring	糸調子バネ	1	1
33	0020118	Thread Tension Spring Retainer(W)	糸調子バネキャップ(下)(白)	4	4
34	000178	Felt(W)(2.5mm)	フェルト(白)	4	4
35	000177	Felt(W)(1.0mm)	フェルト(白)	4	4
36	007903	Tension Post(Long)	糸調子棒(長)	4	4
37	0032952	Thread Tension Spring	糸調子バネ	1	1

Note: (G).....Green colored, (W).....White colored.
(注) (G)は緑色、(W)は白色を表わします。

"C" DEVICE

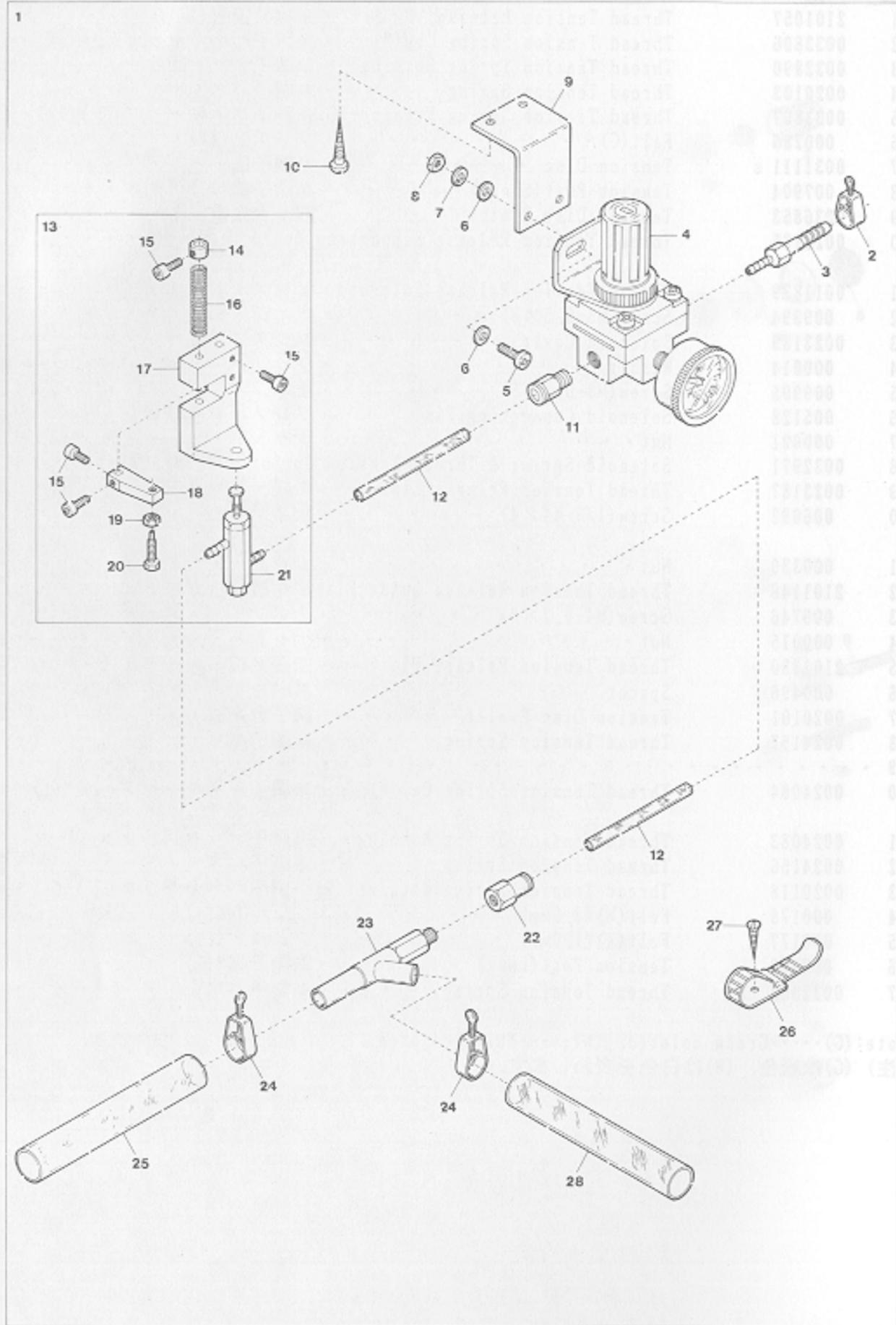

"C" DEVICE

Ref. No.	Parts No.	Description	品名	Amt. Req.
1	2109930	"C" Device, Complete Set	"C"装置(組)	1
2	0033939	Hose Band(1/4 inch)	ホースバンド(1/4インチ)	1
3	1094011	Hose Nipple(PT1/8)	ホースニップル	1
4	1097000	Regulator	レギュレータ	1
5	009960	Screw(M5-0.8×16)	止ネジ	2
6	000669	Washer	ワッシャ	4
7	000600	Spring Washer	スプリングワッシャ	2
8	000009	Nut	ナット	2
9	1097001	Regulator Support	レギュレータ取付板	1
10	006905	Wood Screw(φ5.1×20)	木ネジ	2
11	0010263	Connector(φ6-PT1/8)	コネクタ	1
12	1096000	Nylon Hose(4×6×2000mm)	ナイロンホース	1
13	0033953	Air Valve, Complete Set	エアバルブ(組)	1
14	0033938	Collar	エアバルブ補助パネカラー	1
15	005040	Screw(11/64-40×8.5)	止ネジ	5
16	0033937	Return Spring	エアバルブ補助パネ	1
17	0033936	Air Valve Holder	エアバルブ取付台	1
18	0033935	Air Valve Stop	エアバルブストップ	1
19	000334	Nut	ナット	1
20	005505	Adjusting Screw(11/64-40×16)	調節ネジ	1
21	0033934	Air Valve	エアバルブ	1
22	0010290	Connector(φ6-PT1/8)	継手	1
23	0010310	Venturi Tube	ベンチュリ管	1
24	0033940	Hose Band(3/8 inch)	ホースバンド(3/8インチ)	2
25	1096004	Vinyl Hose(12×18×1500mm)	ビニールホース	1
26	0011987	UL Clamp	ULクランプ	3
27	009814	Wood Screw(φ3.1×20)	木ネジ	3
28	1096005	Vinyl Hose(12×18×500mm)	ビニールホース	1

"C"装置

Note: Size of Collar ... (A) Dia. × (B) Dia. × (C) Thickness

"MT2" DEVICE(1)

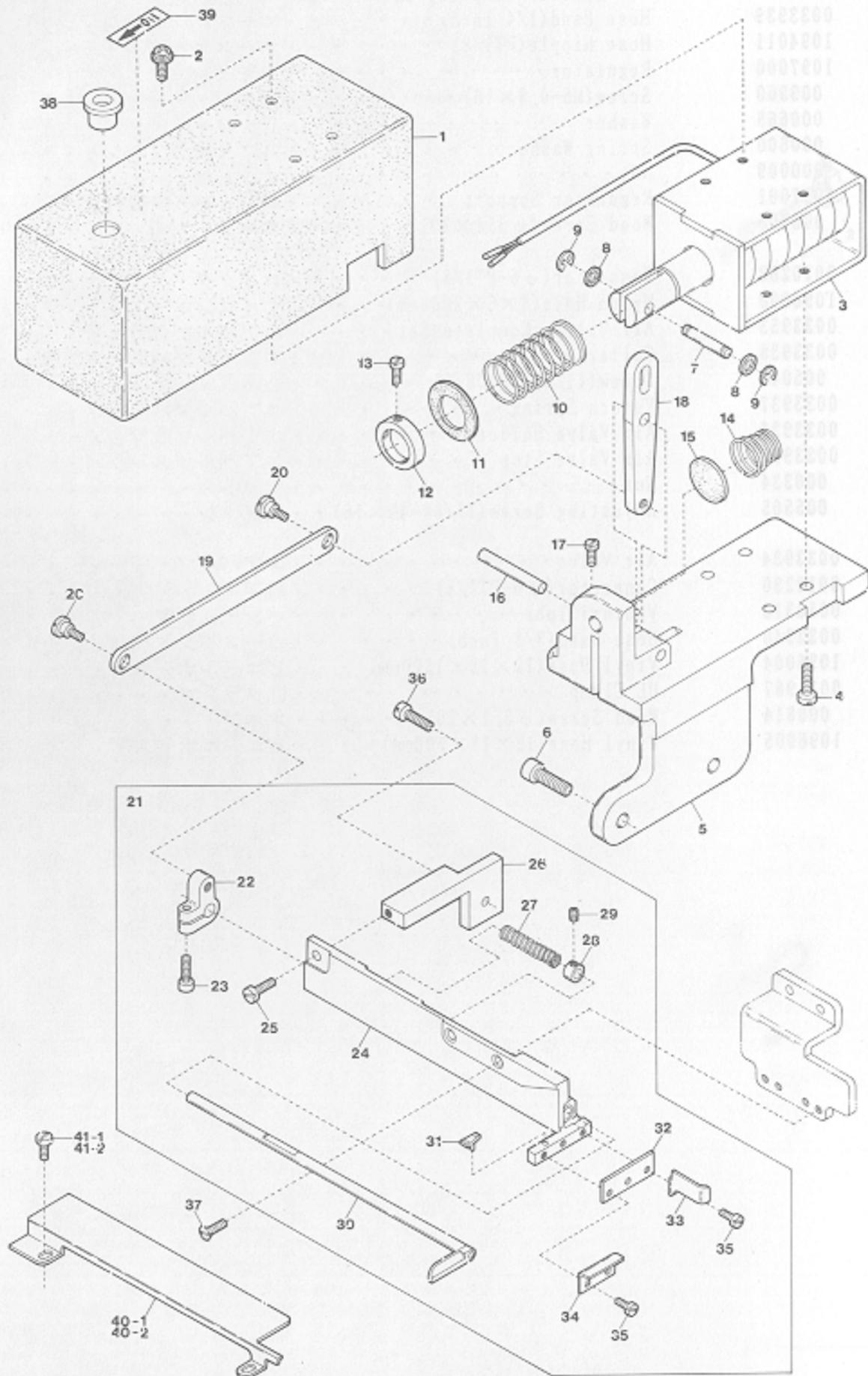

"MT2" DEVICE(1)

Ref.	Parts	Description	品名	Amt.
No.	No.			Req.
1	2101101	Solenoid Cover	ソレノイドカバー	1
2	005625	Screw(M4-0.7×12)	止ネジ	4
3	1062000	Solenoid	ソレノイド	1
4	110016	Screw(M4-0.7×15)	止ネジ	4
5	2101100	Solenoid Holder	ソレノイド取付台	1
6	120013	Screw(M6-1×15)	止ネジ	4
7	2101109	Solenoid Connecting Pin	連結ピン	1
8	000187	Fiber Cushion	防振ファイバー	2
9	0033024	Retaining Ring	ストップリング	2
10	2101106	Solenoid Spring	ソレノイドバネ	1
11	2101105	Spring Receiver	バネ受ケゴム	1
12	0026312	Collar(15.1×21×6mm)	カラー	1
13	005036	Screw(1/8-44×5.6)	止ネジ	2
14	2101137	Anti-shock Spring	緩衝バネ	1
15	2101104	Soundproof Rubber	防音ゴム	1
16	2101103	Solenoid Lever Shaft	ソレノイドレバー軸	1
17	110022	Screw(M3-0.5×10)	止ネジ	1
18	2101171	Solenoid Lever	ソレノイドレバー	1
19	2101107	Upper Knife Connecting Plate	上メス連結板	1
20	004100	Screw(11/64-40×3.2)	止ネジ	2
21	2101121	Trimming Device, Complete Set	メス装置(組)	1
22	2101108	Upper Knife Driving Lever	上メス腕	1
23	120018	Screw(M4-0.7×10)	止ネジ	1
24	2101119	Upper Knife Holder	上メス台	1
25	110039	Screw(M3.5-0.6×10)	止ネジ	1
26	2101136	Upper Knife Holder Fixing Block	上メス台固定台	1
27	0023369	Upper Knife Spring	上メスバネ	1
28	0023368	Collar(6×9×5mm)	上メスカラー	1
29	003637	Screw(1/8-44×2.5)	止ネジ	1
30	2121034	Upper Knife	上メス	1
31	0023220	Upper Knife Rubber Cushion	上メスクッション	1
32	0023370	Lower Knife	下メス	1
33	0026184	Fabric Guide	布ガイド	1
34	0023399	Lower Knife Fabric Guide	下メス布案内板	1
35	001230	Screw(3/32-56×3.8)	止ネジ	3
36	110048	Screw(M4-0.7×10)	止ネジ	1
37	007623	Screw(9/64-40×5.3)	止ネジ	2
38	2101131	Seal Plug	詰栓	1
39	390014	Sticker	貼リマーク	1
40-1	2101122	Cloth Plate Spacer	クロスプレートスペーサ	1
40-2	2101145	" (A26016H)	"	1
41-1	110042	Screw(M3.5-0.6×4)	止ネジ	2
41-2	110050	" (M3.5-0.6×4.5) (A26016H)	"	2

(注) カラーの寸法は内径×外径×幅を表しています。
 Note: Size of Collar ... Inside dia. × Outside dia. × Thickness

"MT2" DEVICE(2)

"MT2"装置(2)

Amt. Req.

"MT2" DEVICE(2)

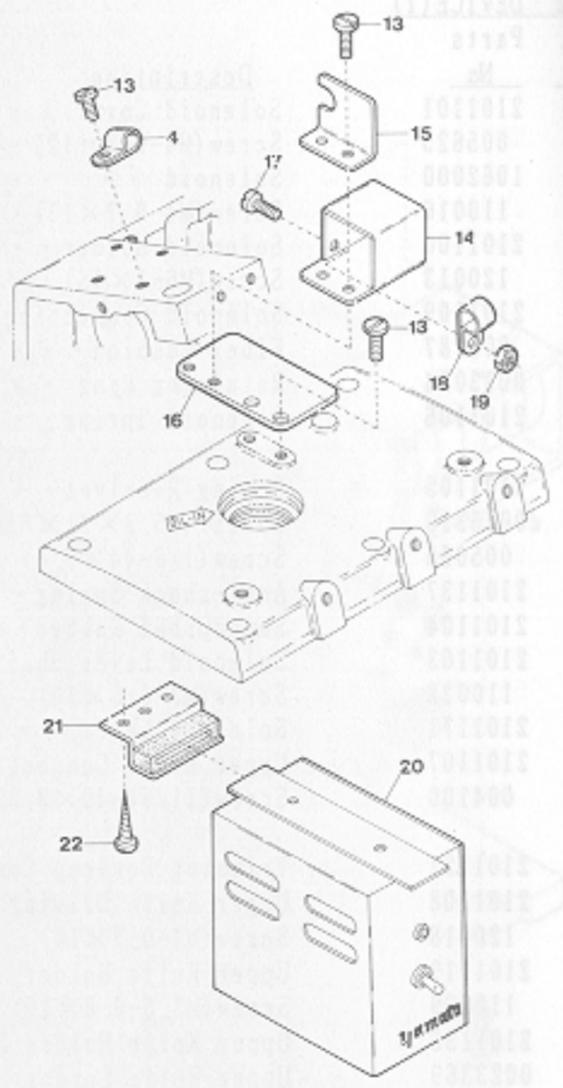
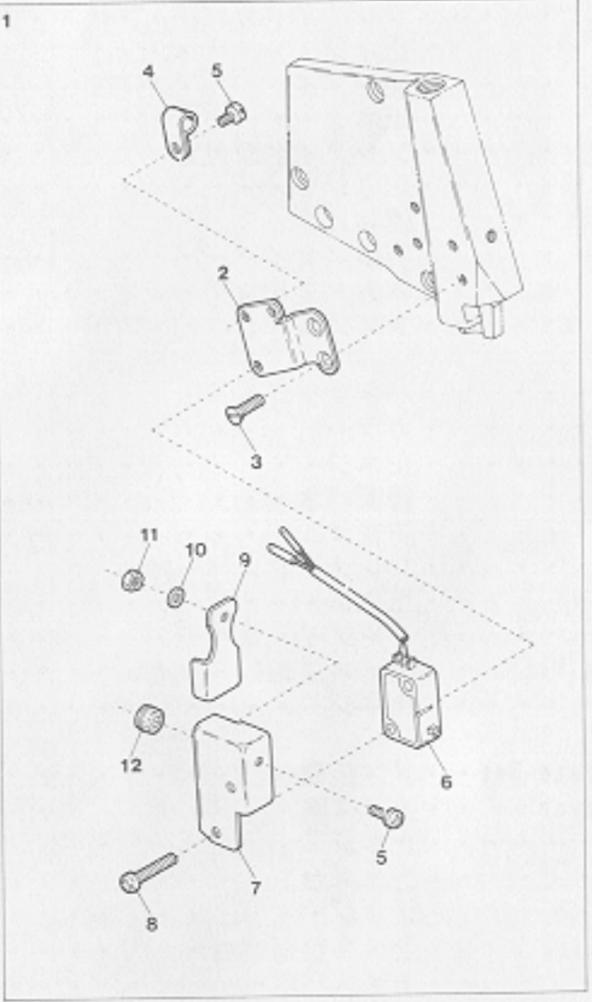

EXTRA PARTS

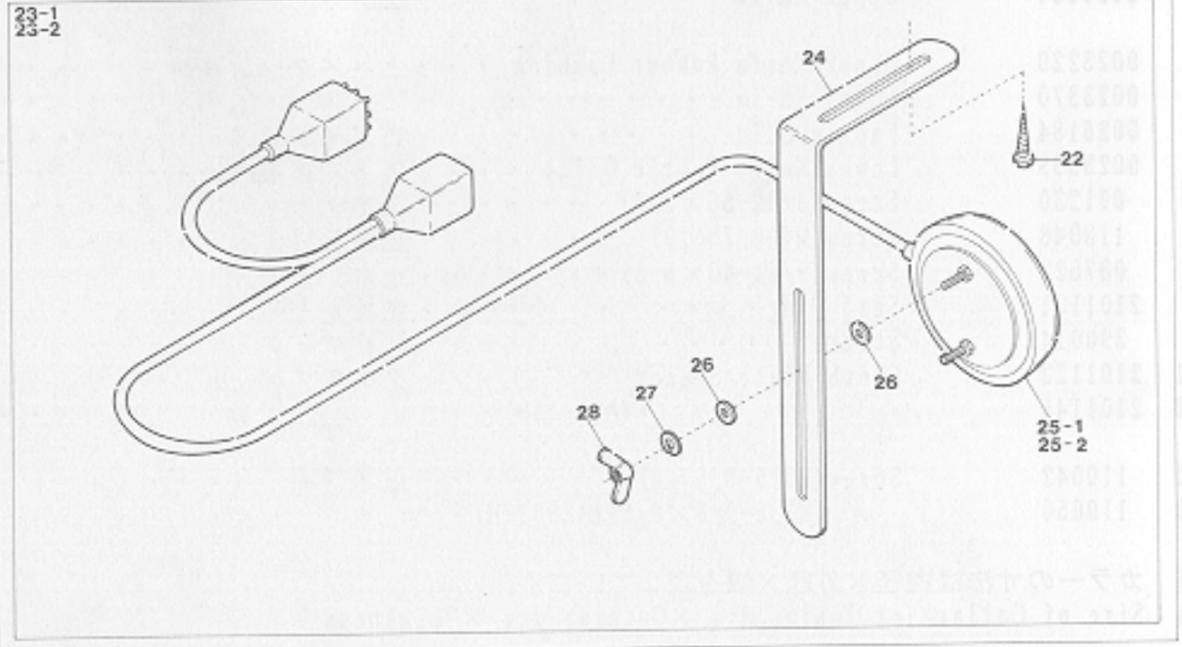

Ref. No.	Parts No.	Description	品名	Amt. Req.
1	1200004	Manual Switch, Complete Set	スイッチ(組)	1
2	2101123	Switch Support	スイッチ取付板	1
3	130003	Screw(M4-0.7×7.3)	止ネジ	2
4	0094491	Cord Clamp(φ3.4-2N)	コードクランプ	2
5	009995	Screw(M3-0.5×5)	止ネジ	2
6	0011967	Switch	スイッチ	1
7	0020989	Switch Cover	スイッチカバー	1
8	009993	Screw(M3-0.5×16)	止ネジ	2
9	0035719	Manual Switch Plate	スイッチ板	1
10	000002	Spring Washer	スプリングワッシャ	1
11	000488	Nut	ナット	1
12	0035722	Cord Bushing	コードブッシュ	1
13	110013	Screw(M4-0.7×8)	止ネジ	5
14	0011840	Connector Case	コネクタケース	1
15	0011841	Connector Case Lid	コネクタケース蓋	1
16	2101452	Connector Case Support	コネクタケース取付板	1
17	110048	Screw(M4-0.7×10)	止ネジ	1
18	0036133	Cord Clamp(φ8.4-5N)	コードクランプ	1
19	100001	Nut	ナット	1
20	0011954	Control Box, Complete Set	MT制御装置(組)	1
21	0011709	Control Box Stay	制御ボックスステイ	2
22	006910	Wood Screw(φ6.8×26)	木ネジ	6
23-1	0011335	Knee Switch, C. Set(for Knee Only)	膝スイッチ(組)(膝のみ)	1
23-2	0011336	" " (for Knee or Finger)	膝スイッチ(組)(膝又は指)	1
24	0092232	Knee Switch Holder	スイッチ取付板	1
25-1	0011338	Knee Switch(for Knee only)	膝スイッチ(膝のみ)	1
25-2	0011339	" " (for Knee or Finger)	膝スイッチ(膝又は指)	1
26	000538	Washer	ワッシャ	4
27	000644	Spring Washer	スプリングワッシャ	2
28	000023	Wing Nut	チョウナット	2

31	0023320	Upper Knife	上メス	1
32	0023370	Lower Knife	下メス	1
33	0020184	Fabric Guide	布ガイド	1
34	0023399	Lower Knife Fabric Guide	下メス布案内板	1
35	0012328	Screw(3/32×2.8)	止ネジ	2
36	1100014	Screw(M4-0.7×10)	止ネジ	2
37	005013	Screw(5/64-16×3.3)	止ネジ	2
38	2101381	Seal Plug	密封栓	2
39	200014	Striker	打リマーク	2

(注) カラーの寸法は内径×外径×長さです。
 Note: Size of Balls: ...



MU5" DEVICE (1)

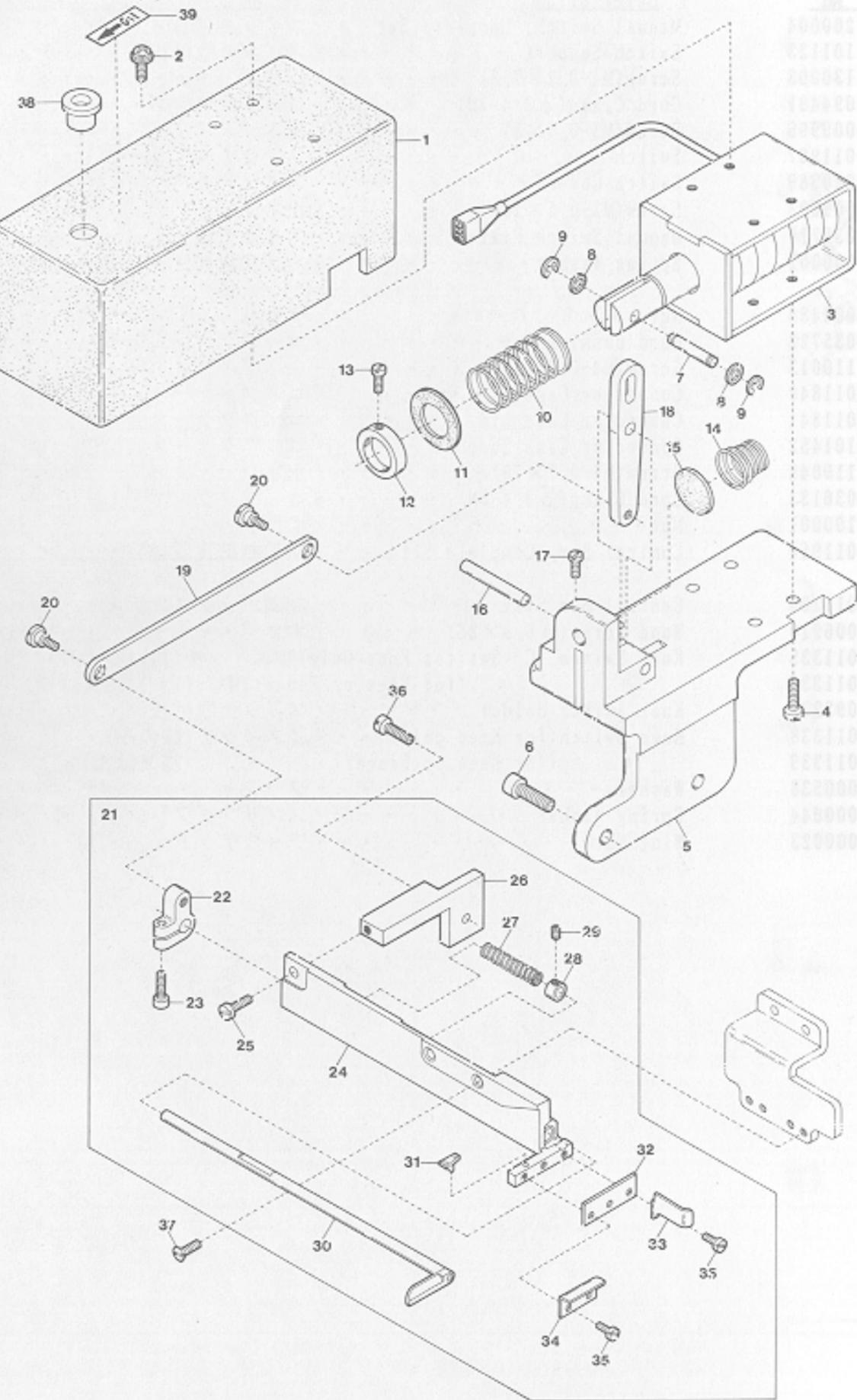

"MU5" DEVICE (1)

Ref. Parts

No.	No.
1	2101101
2	005625
3	1062001
4	110016
5	2101100
6	120013
7	2101109
8	000187
9	0033024
10	2101106
11	2101105
12	0026312
13	005036
14	2101137
15	2101104
16	2101103
17	110022
18	2101171
19	2101107
20	004100
21	2101121
22	2101108
23	120018
24	2101119
25	110039
26	2101136
27	0023369
28	0023368
29	003637
30	2121034
31	0023220
32	0023370
33	0026184
34	0023399
35	001230
36	110048
37	007623
38	2101131
39	390014

Description

Description	品名	Amt.
Solenoid Cover	ソレノイドカバー	1
Screw(M4-0.7×12)	止ネジ	4
Solenoid	ソレノイド	1
Screw(M4-0.7×15)	止ネジ	4
Solenoid Holder	ソレノイド取付台	1
Screw(M6-1×15)	止ネジ	4
Solenoid Connecting Pin	連結ピン	1
Fiber Cushion	防振ファイバー	2
Retaining Ring	ストップリング	2
Solenoid Spring	ソレノイドバネ	1
Spring Receiver	バネ受ケゴム	1
Collar(15.1×21×6mm)	カラー	1
Screw(1/8-44×5.6)	止ネジ	2
Anti-shock Spring	緩衝バネ	1
Soundproof Rubber	防音ゴム	1
Solenoid Lever Shaft	ソレノイドレバー軸	1
Screw(M3-0.5×10)	止ネジ	1
Solenoid Lever	ソレノイドレバー	1
Upper Knife Connecting Plate	上メス連結板	1
Screw(11/64-40×3.2)	止ネジ	2
Trimming Device, Complete Set	メス装置(組)	1
Upper Knife Driving Lever	上メス腕	1
Screw(M4-0.7×10)	止ネジ	1
Upper Knife Holder	上メス台	1
Screw(M3.5-0.6×10)	止ネジ	1
Upper Knife Holder Fixing Block	上メス台固定台	1
Upper Knife Spring	上メスバネ	1
Collar(6×9×5mm)	上メスカラー	1
Screw(1/8-44×2.5)	止ネジ	1
Upper Knife	上メス	1
Upper Knife Rubber Cushion	上メスクッション	1
Lower Knife	下メス	1
Fabric Guide	布ガイド	1
Lower Knife Fabric Guide	下メス布案内板	1
Screw(3/32-56×3.8)	止ネジ	3
Screw(M4-0.7×10)	止ネジ	1
Screw(9/64-40×5.3)	止ネジ	2
Seal Plug	詰栓	1
Sticker	貼りマーク	1

(注) カラーの寸法は内径×外径×幅を表しています。
 Note: Size of Collar ... Inside dia. × Outside dia. × Thickness

"MU5"装置(1)

Amt.

Req.

"MU5" DEVICE (2)

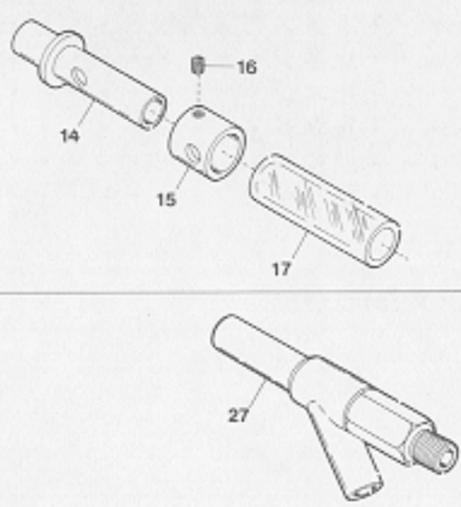
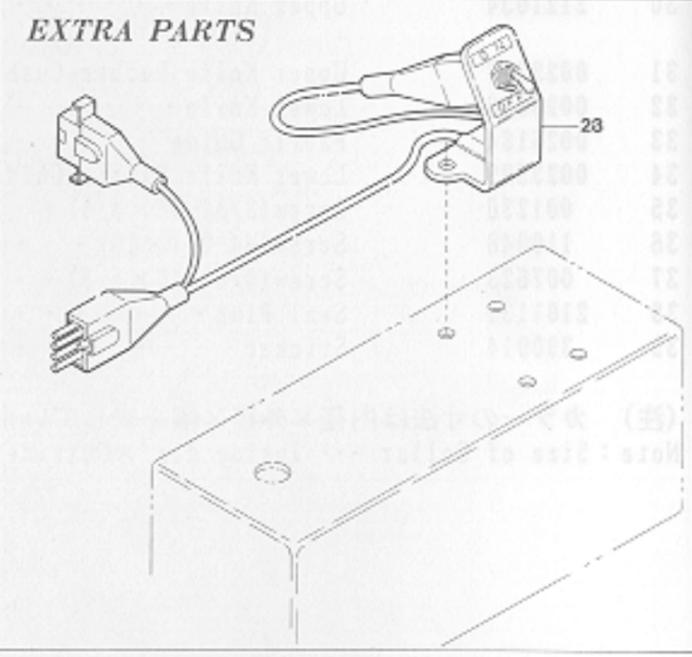
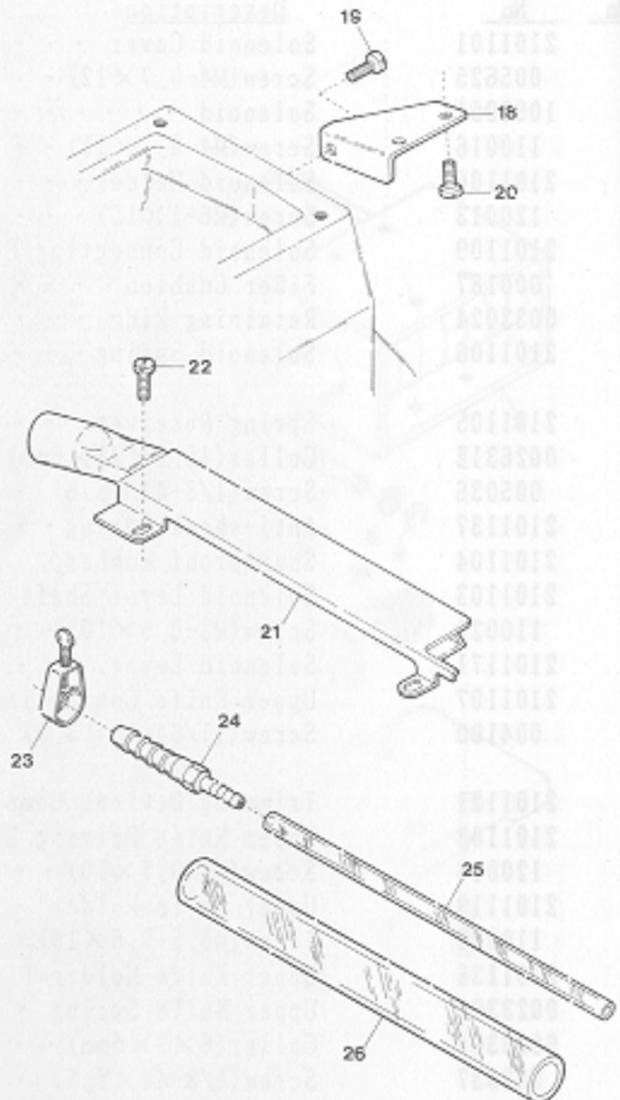
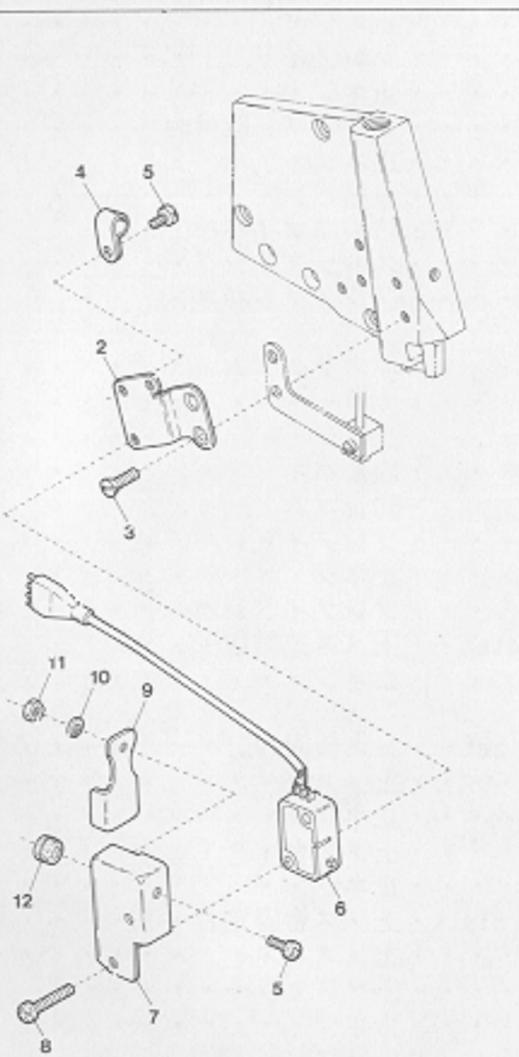

"MU5" DEVICE (2)

Ref. No.	Parts No.
1	1200005
2	2101123
3	130003
4	0094491
5	009995
6	1200021
7	0020989
8	009993
9	0035719
10	000002
11	000488
12	0035722
13	0021451
14	0021457
15	0021456
16	001892
17	0021450
18	2101138
19	110012
20	004358
21	2101115
22	110042
23	0033939
24	0033932
25	0022404
26	0022392
27	0010310
28	1066063

Description	品名	Amt. Req.
Manual Switch, Complete Set	スイッチ(組)	1
Switch Support	スイッチ取付板	1
Screw(M4-0.7×7.3)	止ネジ	2
Cord Clamp(φ3.4-2N)	コードクランプ	1
Screw(M3-0.5×5)	止ネジ	2
Switch	スイッチ	1
Switch Cover	スイッチカバー	1
Screw(M3-0.5×16)	止ネジ	2
Manual Switch Plate	スイッチ板	1
Spring Washer	スプリングワッシャー	1
Nut	ナット	1
Cord Bushing	コードブッシュ	1
Suction Power Control Tube, C. Set	吸引力調整管(組)	1
Suction Power Control Tube(Inner)	吸引力調整台	1
Suction Power Control Tube	吸引力調整管	1
Screw(1/8-44×2.9)	止ネジ	1
Nylon Hose(12×16×50mm)	ナイロンホース	1
Solenoid Stay	ソレノイド支エ	1
Screw(M4-0.7×5)	止ネジ	1
Screw(9/64-40×5.6)	止ネジ	1
Suction Pipe	吸込管	1
Screw(M3.5-0.6×4)	止ネジ	2
Hose Band(1/4 inch)	ホースバンド	1
Joint	ジョイント	1
Nylon Hose(3.8×6×1000mm)	ナイロンホース	1
Nylon Hose(12×18×1000mm)	ナイロンホース	2
Venturi Pipe Unit	ベンチュリ管(組)	1
Supplementary Switch Unit	補助スイッチ(組)	1

"MU5"装置(2)

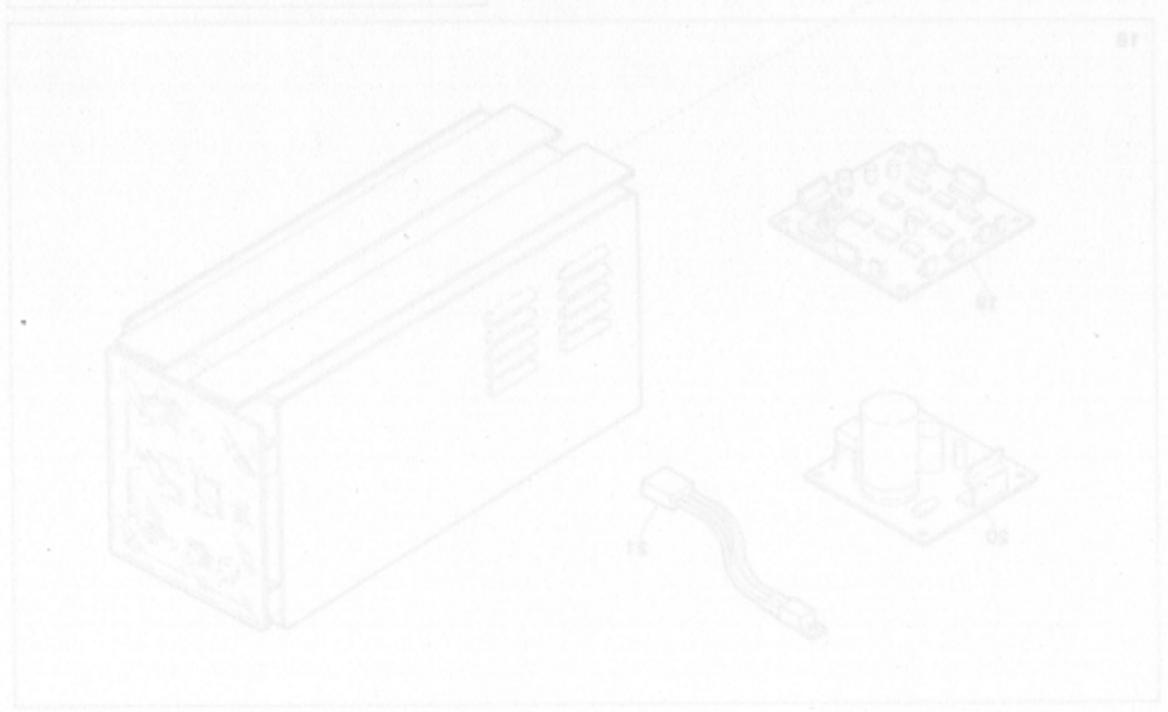

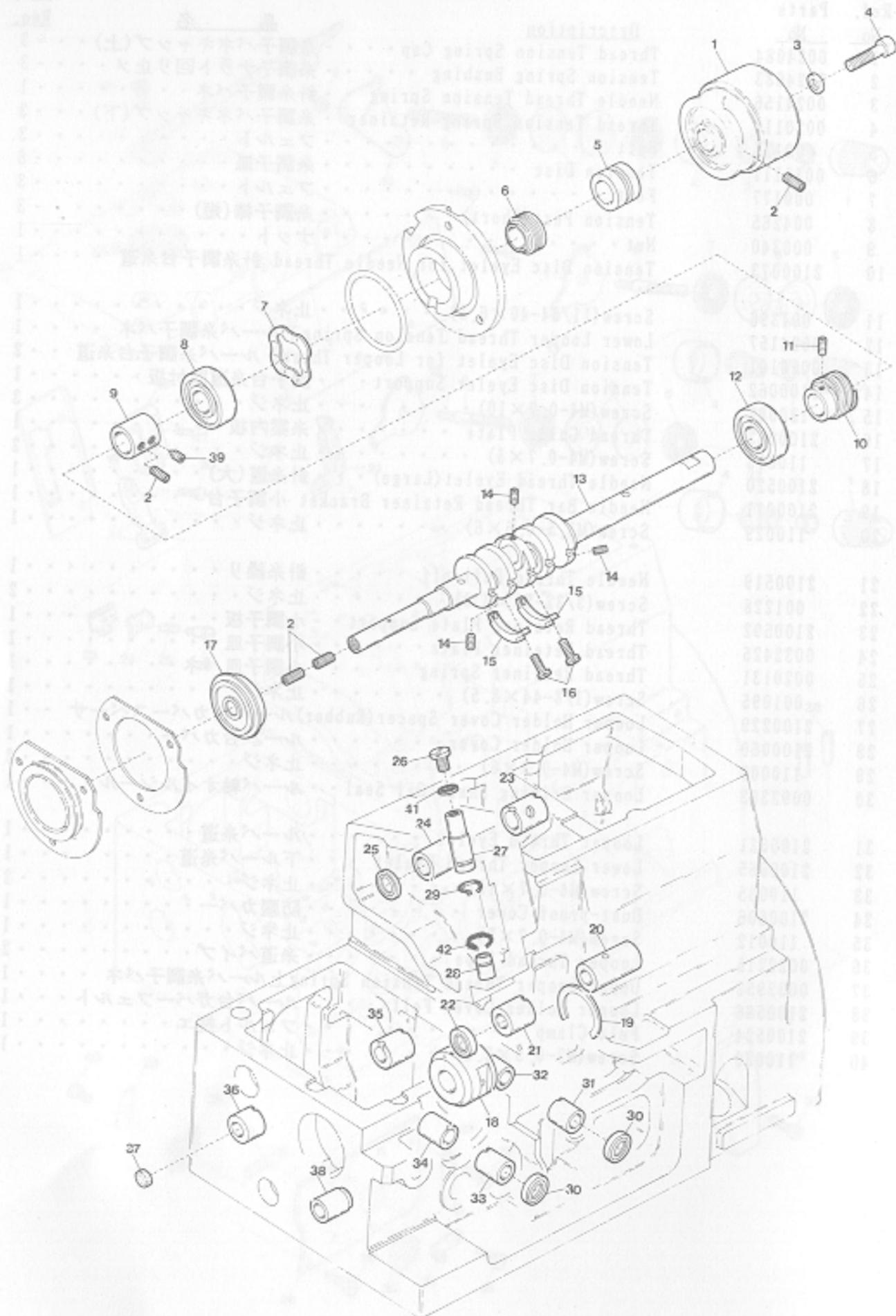

MISCELLANEOUS CRANKSHAFT & BUSHINGS

主軸及びブッシュ関係

Ref. No.	Parts No.	Description	品名	Amt. Req.
1	2100090	Pulley	プーリ	1
2	160007	Screw(M6-1×6)	止ネジ	5
3	000474	Washer	ワッシャ	1
4	009753	Screw(M6-1×30)	止ネジ	1
5	2100625	Mechanical Oil Shield Sleeve	油切りスリーブ	1
6	2100092	Mechanical Oil Shield	油切り	1
7	2100113	Corrugated Washer	波形ワッシャ	1
8	2100121	Crankshaft Ball Bearing(Right)	ボールベアリング(右)	1
9	2100312	Positioning Collar	位置決メカラー	1
10	2100364	Oil Pump Driving Worm	ウォーム	1
11	160001	Screw(M4-0.7×4)	止ネジ	2
12	2100120	Crankshaft Ball Bearing(Center)	ボールベアリング(中)	1
13	2100501	Crankshaft	クランクシャフト	1
14	160000	Screw(M3-0.5×3)	詰ネジ	3
15	2100111	Crankshaft Counterweight	バランスウエイト	2
16	110036	Screw(M3-0.5×6.5)	止ネジ	4
17	2100095	Crankshaft Ball Bearing(Left)	ボールベアリング(左)	1
18	2100109	Crankshaft Bushing	小ブッシュ	1
19	2100112	Retaining Ring	止メ輪	1
20	2100615	Upper Knife Driving Shaft Bushing(Right)	上メス軸ブッシュ(右)	1
21	2100104	Upper Knife Driving Shaft Bushing(Left)	上メス軸ブッシュ(左)	1
22	2100117	Upper Knife Driving Shaft Oil Seal	上メス軸オイルシール	1
23	2110242	Needle Bar Driving Shaft Bushing(Right)	針棒クランク軸ブッシュ(右)	1
24	2110243	Needle Bar Driving Shaft Bushing(Left)	針棒クランク軸ブッシュ(左)	1
25	0032684	Needle Bar Driving Shaft Oil Seal	針棒クランク軸オイルシール	1
26	003636	Cap Screw(5/16-32×3.5)	蓋ネジ	1
27	2100613	Needle Bar Bushing(Upper)	針棒ブッシュ(上)	1
28	2100614	Needle Bar Bushing(Lower)	針棒ブッシュ(下)	1
29	310009	Oil Wick	油芯	1
30	2100272	Looper Driving Shaft Oil Seal	ルーバ軸オイルシール	2
31	2100202	Upper Looper Driving Shaft Bushing(Front)	上ルーバ軸ブッシュ(前)	1
32	2100370	Upper Looper Driving Shaft Bushing(Rear)	上ルーバ軸ブッシュ(後)	1
33	2100114	Lower Looper Driving Shaft Bushing(Front)	下ルーバ軸ブッシュ(前)	1
34	2100617	Lower Looper Driving Shaft Bushing(Rear)	下ルーバ軸ブッシュ(後)	1
35	2100609	Feed Bar Driving Shaft Bushing(Right)	送り軸ブッシュ(右)	1
36	2100096	Feed Bar Driving Shaft Bushing(Left)	送り軸ブッシュ(左)	1
37	2100034	Seal Plug	詰栓	1
38	2100610	Control Lever Shaft Bushing	送り調節レバー軸ブッシュ	1
39	160005	Screw(M6-1×8)	止ネジ	1
40				
41	000526	Casket	パッキン	1
42	310021	Oil Wick(Laced Wire)	油芯(モール)	1

Note: Size

"MU5" DEVICE(3)

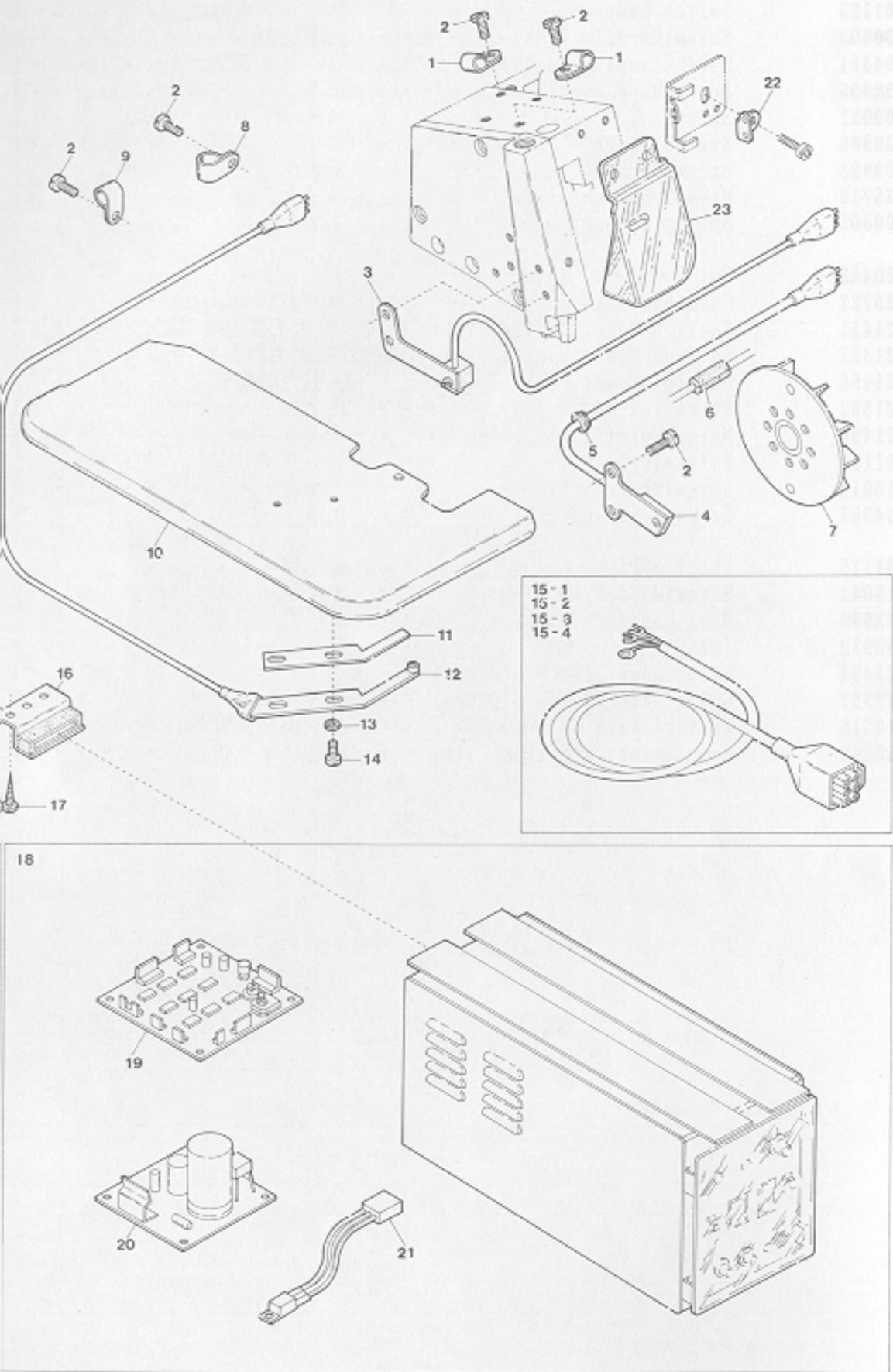

"MU5" DEVICE(3)

Ref. Parts

No	No
1	0060248
2	110013
3	1200202
4	1200001
5	0035722
6	2101124
7	2101045
8	0010291
9	0094491
10	2101113
11	0011995
12	1200198
13	300007
14	110102
15-1	0011943
15-2	0011944
15-3	0011945
15-4	0011946
16	0011709
17	006910
18	0011930
19	1057086
20	0011973
21	0011974
22	2101116
23	2100082

Description

Cord Clamp(φ 5.3-3N)	コードクランプ	2
Screw(M4-0.7×8)	止ネジ	6
Light Emitter Unit	投光器(組)	1
Rotation Detector Unit	ホールIC(組)	1
Cord Bushing	コードブッシュ	1
Cord Bushing	コードブッシュ	1
Oil Cooling Fan Magnet Unit	ファンマグネット(組)	1
Cord Clamp(φ 13.2-8N)	コードクランプ	1
Cord Clamp(φ 3.4-2N)	コードクランプ	1
Cloth Plate	クロスプレート	1
Insulating Plate	絶縁板	1
Emission Catcher Unit	受光器(組)	1
Washer	ワッシャ	2
Screw(M2.5-0.45×5)	止ネジ	2
Power Cord(for 100 Voltage)	電源コード(100V用)	1
" (" 200 ")	" (200")	1
" (" 220 ")	" (220")	1
" (" 380 ")	" (380")	1
Control Box Stay	制御ボックスステイ	4
Wood Screw(φ 6.8×26)	木ネジ	8
Control Box, Complete Set	制御装置(組)	1
Control Board	MU制御基板	1
Power Board	MU電源基板	1
Voltage Regulator	定電圧IC	1
Tension Disc Auxiliary Eyelet	調子台補助糸道	1
Safety Plate	アイガード	1

"MU5"装置(3)

Amt. Req.

"MU5" DEVICE (4)

AZ6003H/MU5

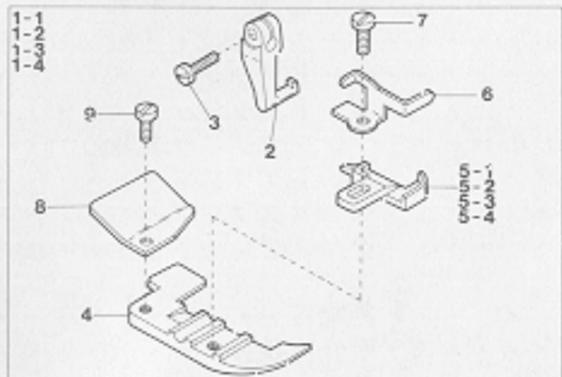

AZ6020H/MU5

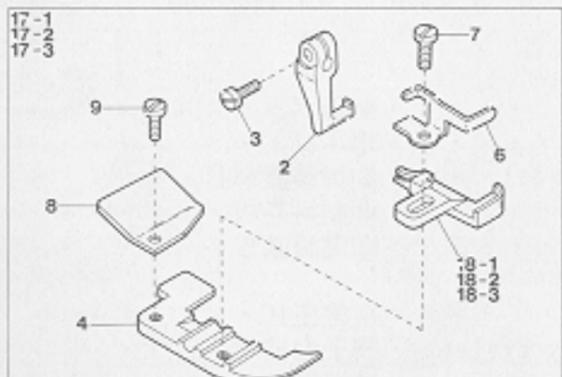

AZ6025H/MU5

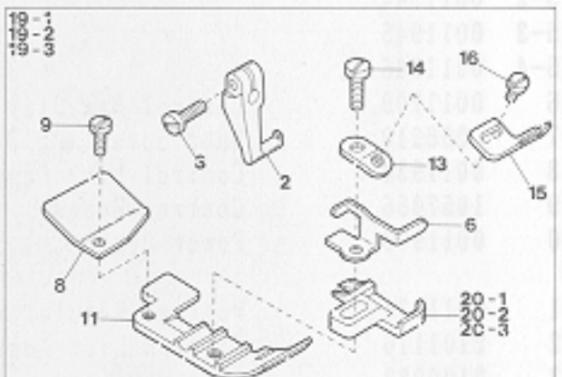

"MU5" DEVICE(4)

Ref. No.	Parts No.	Description	品名	51 Amt. Req.
1-1	2107320	Presser Foot, Complete Set(03)	押エ(組)	1
1-2	2107321	Thread Tension Spring " (04)	"	1
1-3	2107322	Thread Tension Spring " (05)	"	1
1-4	2107323	Thread Tension Spring " (06)	"	1
2	0024100	Presser Foot Hinge	押エヒンジ	1
3	004351	Screw(9/64-40×7)	止ネジ	1
4	2107280	Presser Foot(Lower)	押エ(下)	1
5-1	2107220	Presser Foot Stitch Tongue(03)	爪	1
5-2	2107221	" " (04)	"	1
5-3	2107222	Thread Tension Spring " (05)	"	1
5-4	2107223	" " (06)	"	1
6	2107162	Presser Foot Hinge Spring	押エヒンジバネ	1
7	005036	Screw(1/8-44×5.6)	止ネジ	1
8	0022416	Presser Foot Chain Shield	空糸押エ	1
9	004237	Screw(3/32-56×2.6)	止ネジ	1
10				
11	2107290	Presser Foot(Lower)	押エ(下)	1
12				
13	2107173	Tape Guide Support	テープガイド取付板	1
14	210005	Screw(1/8-44×7.1)	止ネジ	1
15	2107174	Presser Foot Tape Guide	押エテープガイド	1
16	001228	Screw(3/32-56×3.2)	止ネジ	1
17-1	2107324	Presser Foot, Complete Set(Y5)	押エ(組)	1
17-2	2107325	" " (Y6)	"	1
17-3	2107326	" " (X4)	"	1
18-1	2107230	Presser Foot Stitch Tongue(Y5)	爪	1
18-2	2107231	" " (Y6)	"	1
18-3	2107232	" " (X4)	"	1
19-1	2107330	Presser Foot, Complete Set(Y5)	押エ(組)	1
19-2	2107331	Screw " (Y6)	"	1
19-3	2107328	Thread " " (X4)	"	1
20-1	2107240	Presser Foot Stitch Tongue(Y5)	爪	1
20-2	2107241	Thread " " (Y6)	"	1
20-3	2107238	Thread " " (X4)	"	1

Note: (G) Green (W) White colored.

(注) (G)緑色 (W)白色

"MU5"装置(4)

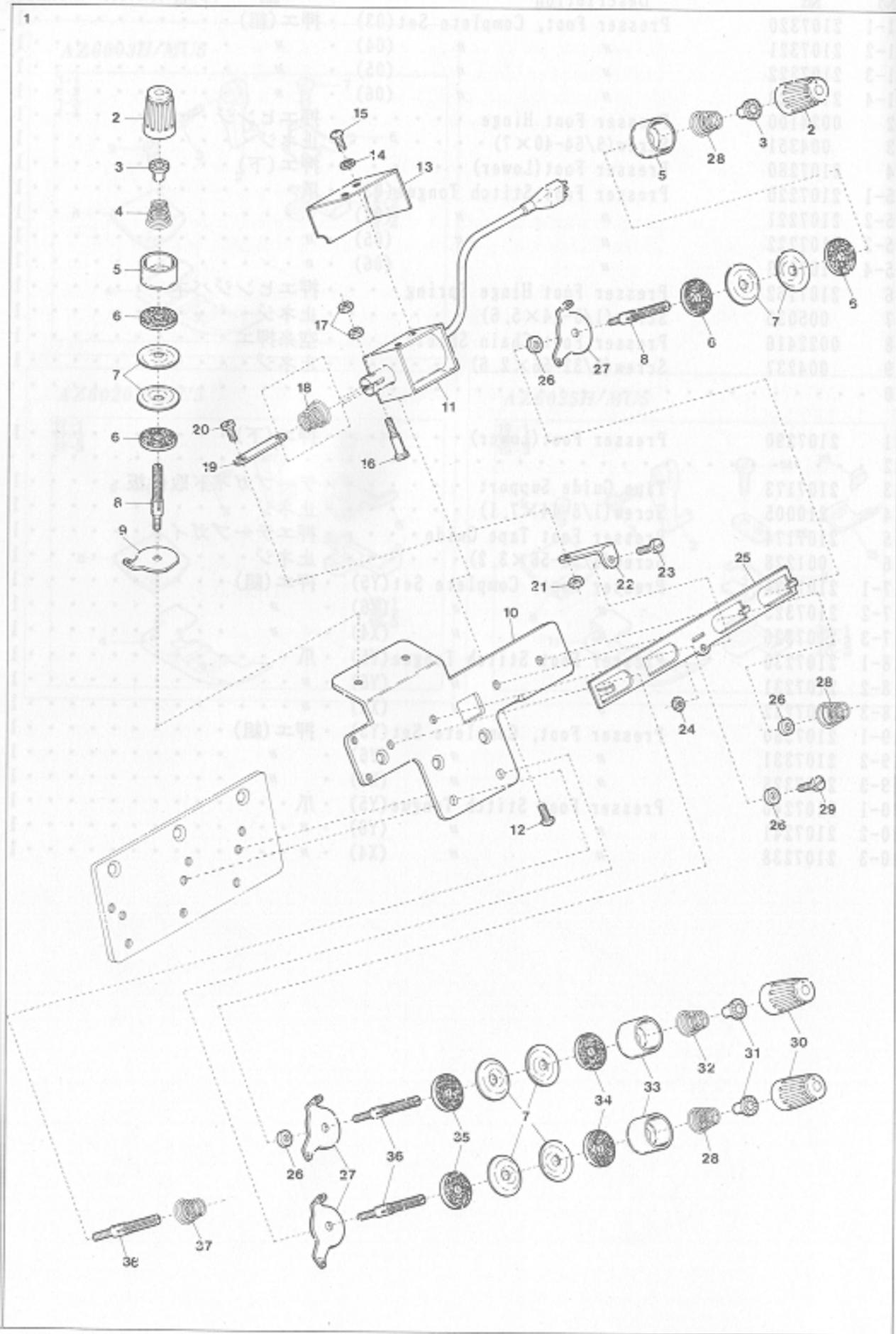

Ref. No.	Parts No.	Description	品名	Amt.	Req.
1	2101117	Thread Tension Release, C. Set	糸緩メ装置(組)	1	1
2	0033806	Thread Tension Spring Cap(G)	糸調子バネキャップ(上)(緑)	3	3
3	0033890	Thread Tension Spring Bushing	糸調子ナット回り止メ	3	3
4	0020103	Thread Tension Spring	糸調子バネ	1	1
5	0033807	Thread Tension Spring Retainer(G)	糸調子バネキャップ(下)(緑)	3	3
6	000286	Felt(G)	フェルト(緑)	6	6
7	0031111	Tension Disc	糸調子皿	12	12
8	007904	Tension Post(Short)	糸調子棒(短)	3	3
9	0036853	Tension Disc Eyelet	調子台糸道	1	1
10	0023185	Thread Tension Release Supporting Board	糸緩メ台	1	1
11	0011942	Thread Tension Release Solenoid	ソレノイド	1	1
12	009994	Screw(M3-0.5×8)	止ネジ	2	2
13	0023189	Solenoid Cover	ソレノイドカバー	1	1
14	000014	Washer	ワッシャ	2	2
15	009995	Screw(M3-0.5×5)	止ネジ	2	2
16	005128	Solenoid Connecting Pin	ソレノイド連結ピン	1	1
17	000021	Nut	ナット	2	2
18	0032971	Solenoid Spring	ソレノイドバネ	1	1
19	0023187	Thread Tension Release Link	糸緩メリンク	1	1
20	006092	Screw(1/8-44×4)	止ネジ	1	1
21	000330	Nut	ナット	1	1
22	2101148	Thread Tension Release Plate Guide	糸緩メ板ガイド	1	1
23	009746	Screw(M4-0.7×8)	止ネジ	1	1
24	000015	Nut	ナット	1	1
25	2101329	Thread Tension Release Plate	糸緩メ板	1	1
26	000496	Spacer	スペーサ	4	4
27	0020101	Tension Disc Eyelet	調子台糸道	5	5
28	0024157	Thread Tension Spring	糸調子バネ	3	3
29	009853	Screw(11/64-40×6.5)	止ネジ	1	1
30	0024084	Thread Tension Spring Cap(W)	糸調子バネキャップ(上)(白)	3	3
31	0024083	Thread Tension Spring Bushing	糸調子ナット回り止メ	3	3
32	0024156	Thread Tension Spring	糸調子バネ	1	1
33	0020118	Thread Tension Spring Retainer(W)	糸調子バネキャップ(下)(白)	3	3
34	000178	Felt(W)(2.5mm)	フェルト(白)	3	3
35	000177	Felt(W)(1.0mm)	フェルト(白)	3	3
36	007903	Tension Post(Long)	糸調子棒(長)	3	3
37	0032952	Thread Tension Spring	糸調子バネ	1	1

Note:(G).....Green colored, (W).....White colored.
 (注) (G)は緑色、(W)は白色を表わします。

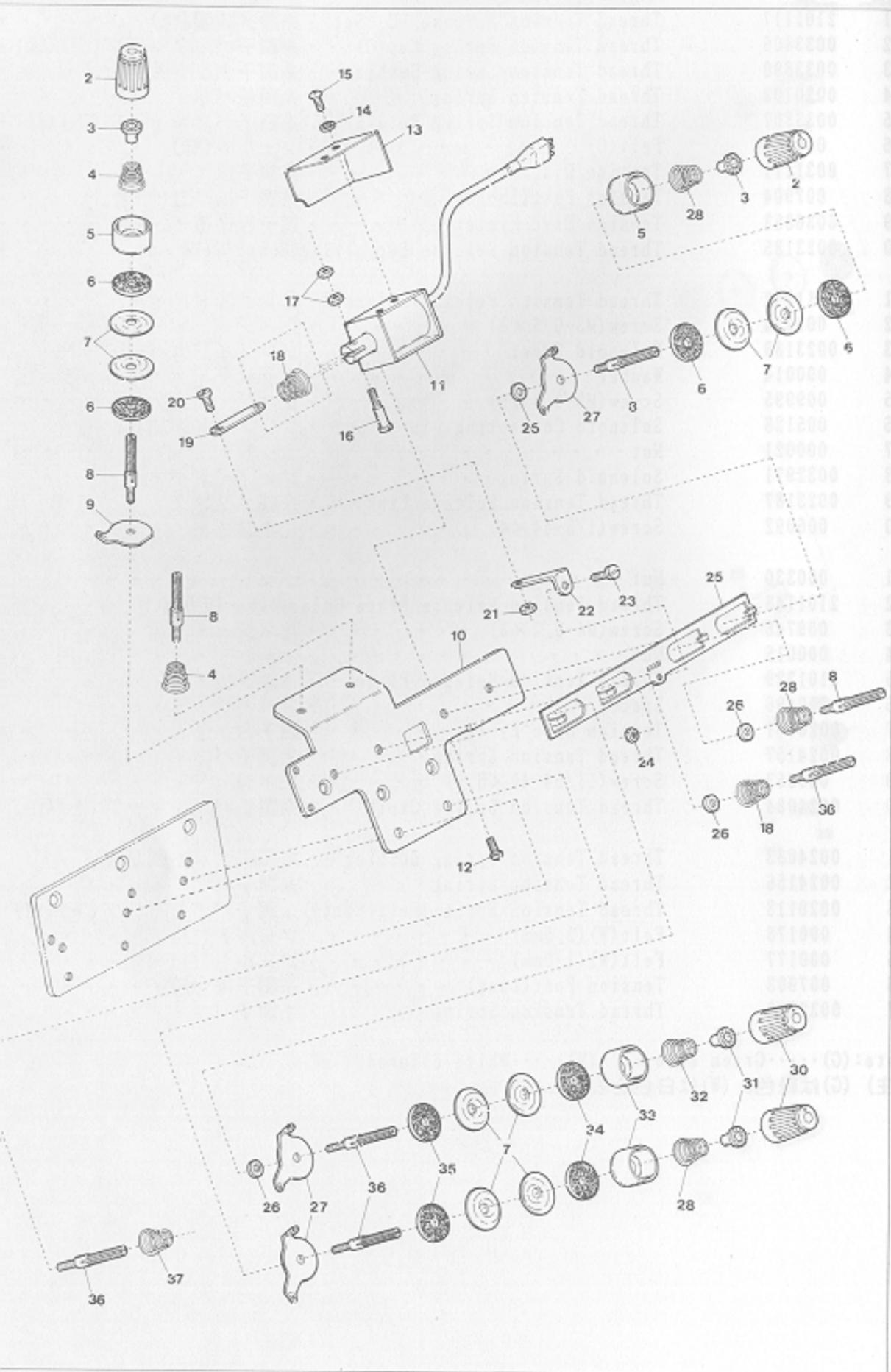

Ref. No.	Parts No.	Description	品名	Amt. Req.
1	2101118	Thread Tension Release, C. Set	糸緩メ装置(組)	1
2	0033806	Thread Tension Spring Cap(G)	糸調子バネキャップ(上)(緑)	4
3	0033890	Thread Tension Spring Bushing	糸調子ナット回り止メ	4
4	0020103	Thread Tension Spring	糸調子バネ	2
5	0033807	Thread Tension Spring Retainer(G)	糸調子バネキャップ(下)(緑)	4
6	000286	Felt(G)	フェルト(緑)	8
7	0031111	Tension Disc	糸調子皿	16
8	007904	Tension Post(Short)	糸調子棒(短)	4
9	0036853	Tension Disc Eyelet	調子台糸道	2
10	0023185	Thread Tension Release Supporting Board	糸緩メ台	1
11	0011942	Thread Tension Release Solenoid	ソレノイド	1
12	009994	Screw(M3-0.5×8)	止ネジ	2
13	0023189	Solenoid Cover	ソレノイドカバー	1
14	000014	Washer	ワッシャ	2
15	009995	Screw(M3-0.5×5)	止ネジ	2
16	005128	Solenoid Connecting Pin	ソレノイド連結ピン	1
17	000021	Nut	ナット	2
18	0032971	Solenoid Spring & Thread Tension Spring	ソレノイドバネ、糸調子バネ	2
19	0023187	Thread Tension Release Link	糸緩メリンク	1
20	006092	Screw(1/8-44×4)	止ネジ	1
21	000330	Nut	ナット	1
22	2101148	Thread Tension Release Guide Plate	糸緩メ板ガイド	1
23	009746	Screw(M4-0.7×8)	止ネジ	1
24	000015	Nut	ナット	1
25	2101330	Thread Tension Release Plate	糸緩メ板	1
26	000496	Spacer	スペーサ	4
27	0020101	Tension Disc Eyelet	調子台糸道	6
28	0024157	Thread Tension Spring	糸調子バネ	3
29				
30	0024084	Thread Tension Spring Cap(W)	糸調子バネキャップ(上)(白)	4
31	0024083	Thread Tension Spring Bushing	糸調子ナット回り止メ	4
32	0024156	Thread Tension Spring	糸調子バネ	1
33	0020118	Thread Tension Spring Retainer(W)	糸調子バネキャップ(下)(白)	4
34	000178	Felt(W)(2.5mm)	フェルト(白)	4
35	000177	Felt(W)(1.0mm)	フェルト(白)	4
36	007903	Tension Post(Long)	糸調子棒(長)	4
37	0032952	Thread Tension Spring	糸調子バネ	1

Note: (G).....Green colored, (W).....White colored.
 (注) (G)は緑色、(W)は白色を表わします。

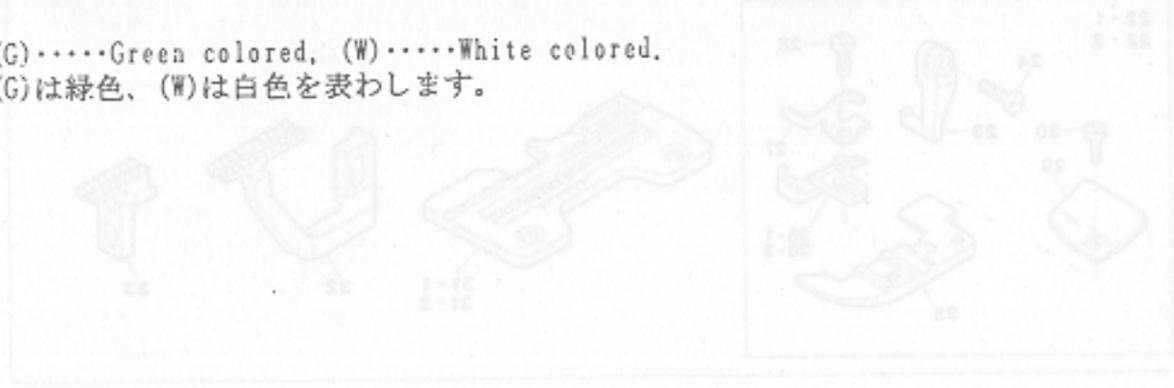

“MS” DEVICE

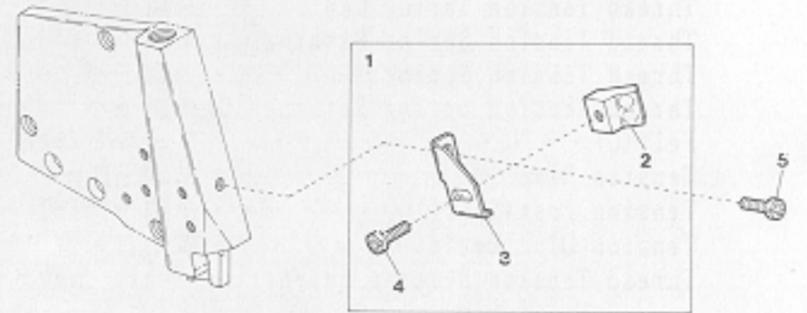

“B3” DEVICE

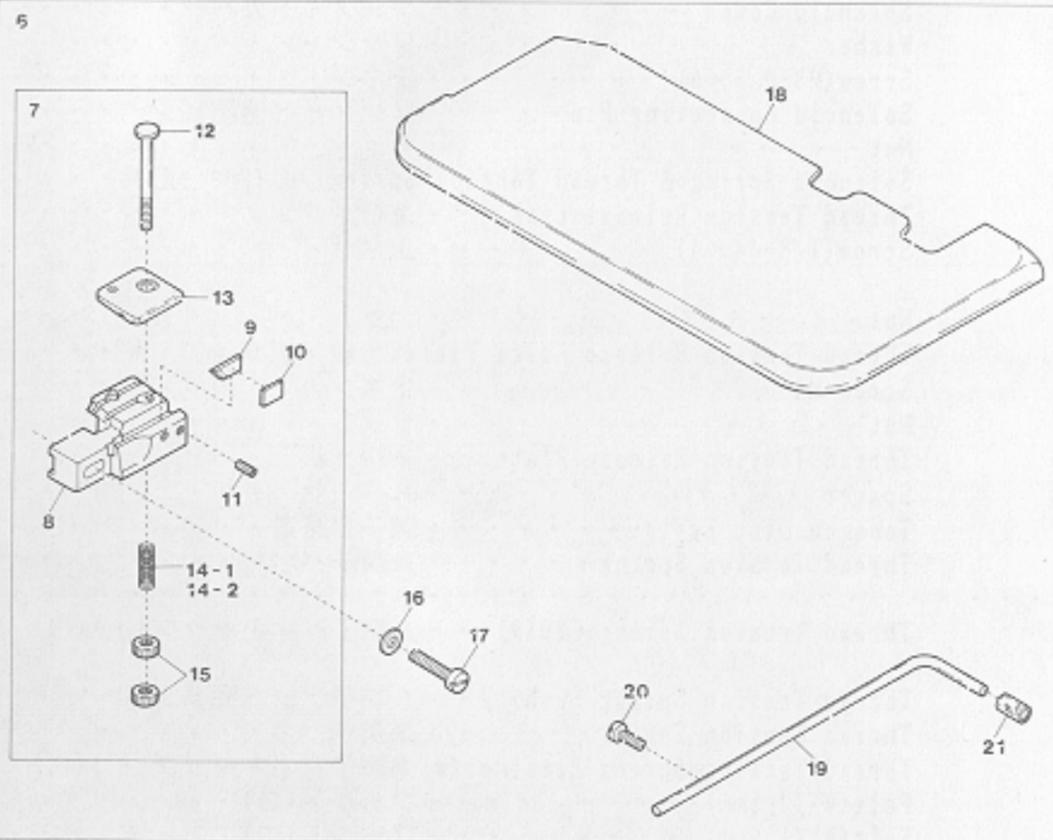

AZ6003H/MS/B3

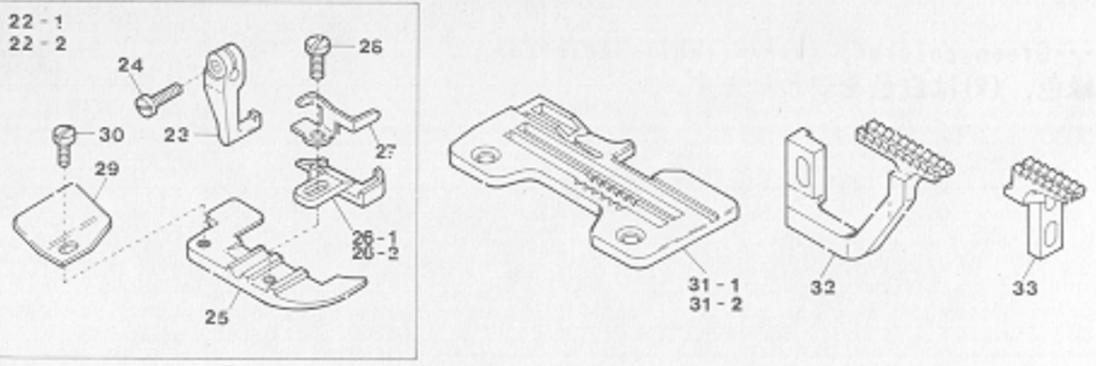

“MS” & “B3” DEVICE

Ref. No	Parts No	Description	品名	Amt. Req
1	2101182	“MS” Device, Complete Set	“MS”装置(組)	1
2	2100079	Magnet Unit	マグネット	1
3	2100076	Magnet Unit Support	マグネット受ケ	1
4	110012	Screw(M4-0.7×5)	止ネジ	1
5	110013	Screw(M4-0.7×8)	止ネジ	1
6	2109907	“B3” Device, Complete Set	“B3”装置(組)	1
7	2101133	Back Tuck Cutting Unit	空環切り装置(組)	1
8	2101134	Chain-off Cutting Knife Holder	刃取付台	1
9	0023184	Chain-off Cutting Knife	刃	1
10	0023169	Chain-off Cutting Knife Holder Spacer	刃取付台スペーサ	1
11	003637	Screw(1/8-44×2.5)	止ネジ	2
12	004205	Screw(11/64-40×18)	止ネジ	1
13	0024308	Chain-off Holder	空環押エ	1
14-1	0023182	Chain-off Holder Spring(Standard)	空環押エバネ(標準)	1
14-2	0033711	“ ” (with Stronger Pressure)	空環押エバネ(バネ強い)	1
15	000361	Adjusting Nut	空環押エバネ調節ナット	2
16	000535	Washer	ワッシャ	1
17	110044	Screw(M3.5-0.6×14)	止ネジ	1
18	2101050	Cloth Plate	クロスプレート	1
19	0036905	Synchronizer Positioning Pin	ポジションナピン	1
20	110009	Screw(M4-0.7×8)	止ネジ	1
21	0022837	Synchronizer Cushion	ポジションナピンクッション	1
22-1	2107317	Presser Foot, Complete Set(03)	押エ(組)	1
22-2	2107318	“ ” “ ” (04)	“ ”	1
23	0024100	Presser Foot Hinge	押エヒンジ	1
24	004351	Screw(9/64-40×7)	止ネジ	1
25	2107280	Presser Foot(Lower)(03)(04)	押エ(下)	1
26-1	2107224	Presser Foot Stitch Tongue(03)	爪	1
26-2	2107225	“ ” “ ” (04)	“ ”	1
27	2107162	Presser Foot Hinge Spring	押エヒンジバネ	1
28	005036	Screw(1/8-44×5.6)	止ネジ	1
29	0034535	Presser Foot Chain Shield	空糸押エ	1
30	004237	Screw(3/32-56×1.7)	止ネジ	1
31-1	2108011	Stitch Plate(03)	針板	1
31-2	2108008	“ ” (04)	“ ”	1
32	2109010	Differential Feed Dog	前送り	1
33	2109011	Main Feed Dog	後送り	1

"BT13" DEVICE(1)

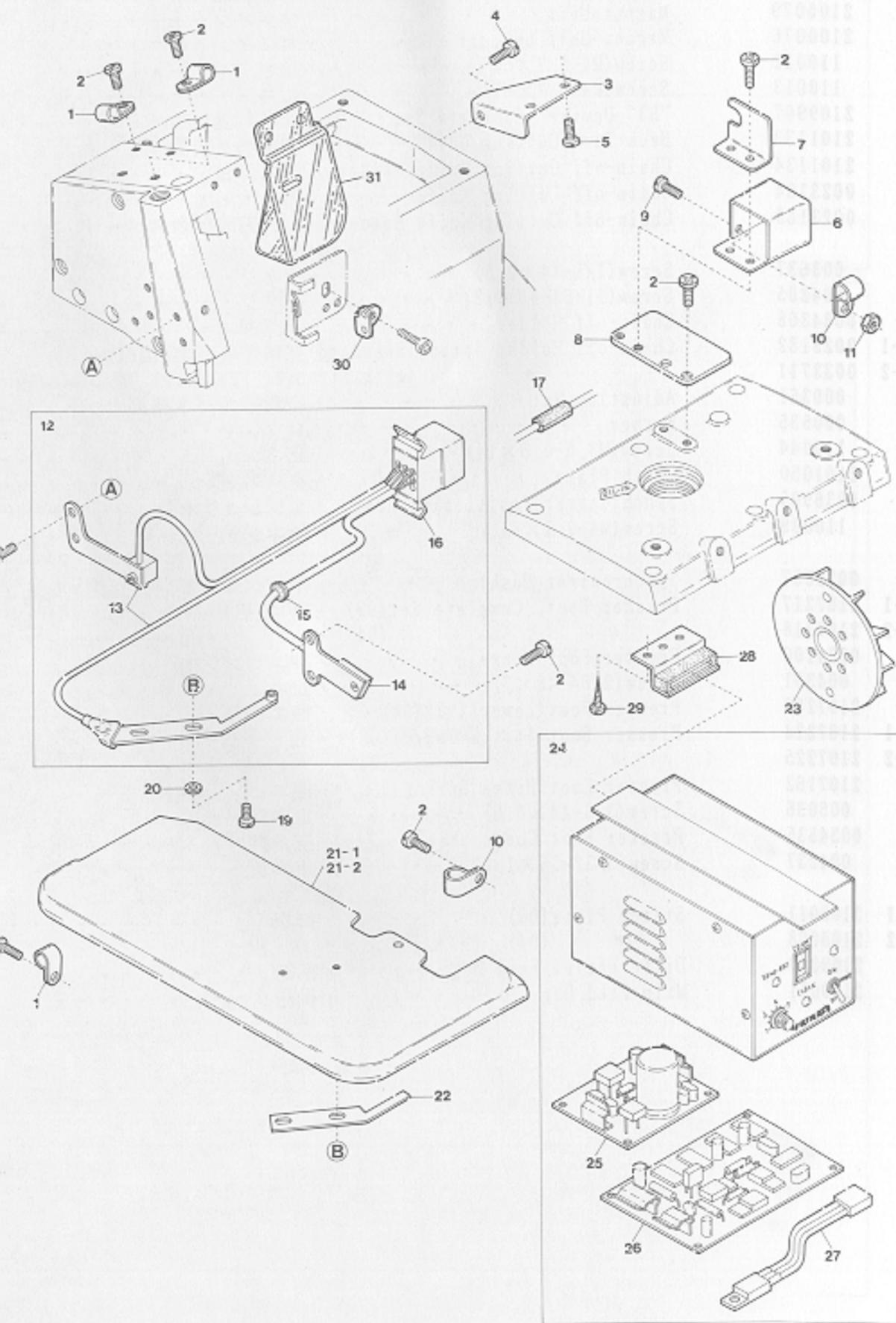

"BT13" DEVICE(1)

Ref. Parts

No.	No.
1	0094491
2	110013
3	2101138
4	110012
5	004358
6	0011840
7	0011841
8	2101452
9	110048
10	0036133
11	100001
12	1200011
13	1200009
14	1200008
15	0035722
16	1070001
17	2101124
18	110001
19	110102
20	300007

21-1	2101054
21-2	2101055
22	0011995
23	2101045
24	0011322
25	0011324
26	1057013
27	0011974
28	0011709
29	006910
30	2101116

31	2100082
----	---------

"BT13"装置(1)

5 5

Amt.

Req.

Description	品名	Amt.
Cord Clamp(φ 3.4-2N)	コードクランプ	3
Screw(M4-0.7×8)	止ネジ	9
Solenoid Stay	ソレノイド支エ	1
Screw(M4-0.7×5)	止ネジ	2
Screw(9/64-40×5.6)	止ネジ	1
Connector Case	コネクタケース	1
Connector Case Lid	コネクタケース蓋	1
Connector Case Support	コネクタケース取付板	1
Screw(M4-0.7×10)	止ネジ	1
Cord Clamp(φ 8.4-5N)	コードクランプ	2
Nut	ナット	1
Rotation & Fabric Detector Switch, C. Set	ホムIC・輝スイッチ(組)	1
Fabric Detector Switch Unit	光電スイッチ(組)	1
Rotation Detector Unit	ホールIC(組)	1
Cord Bushing	コードブッシュ	1
Connector(9P)	コネクタ	1
Cord Bushing	コードブッシュ	1
Screw(M4-0.7×5.4)	止ネジ	2
Screw(M2.5-0.45×5)	止ネジ	2
Washer	ワッシャ	2
Cloth Plate(AZ6003H)	クロスプレート	1
" (AZ6020H)	"	1
Insulating Plate	絶縁板	1
Oil Cooling Fan Magnet Unit	ファンマグネット(組)	1
Control Box, Complete Set	制御装置(組)	1
Power Board	電源基板	1
Control Board	制御基板	1
Voltage Regulator	定電圧IC	1
Control Box Stay	制御ボックスステイ	2
Wood Screw(φ 6.3×26)	木ネジ	4
Tension Disc Auxiliary Eyelet	調子台補助糸道	1
Safety Plate	アイガード	1

"BT13" DEVICE(2)

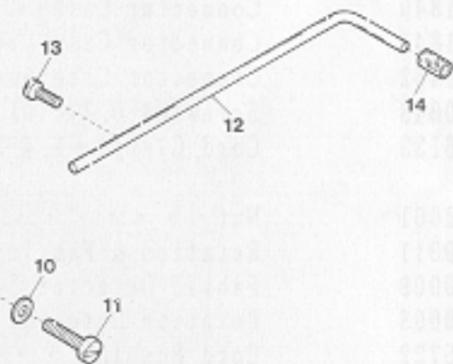
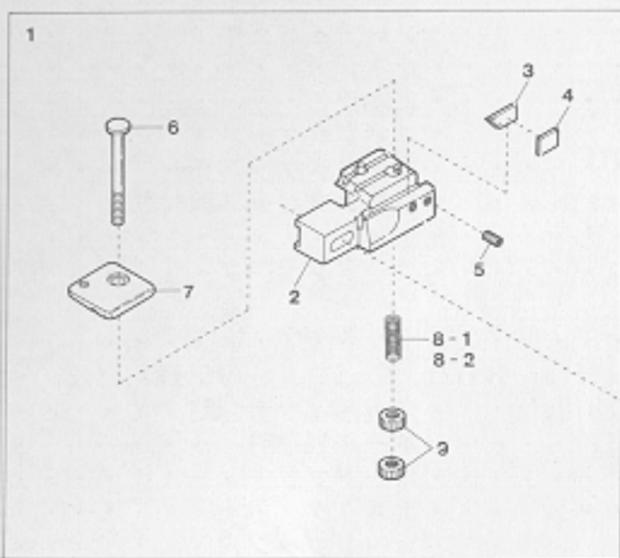

AZ6003H/BT13

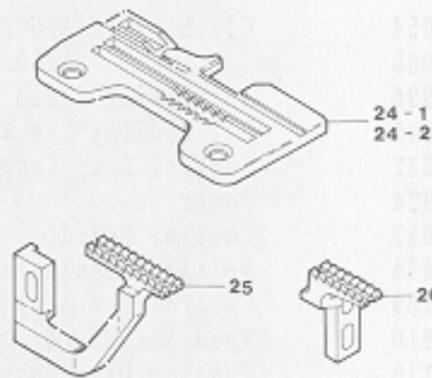
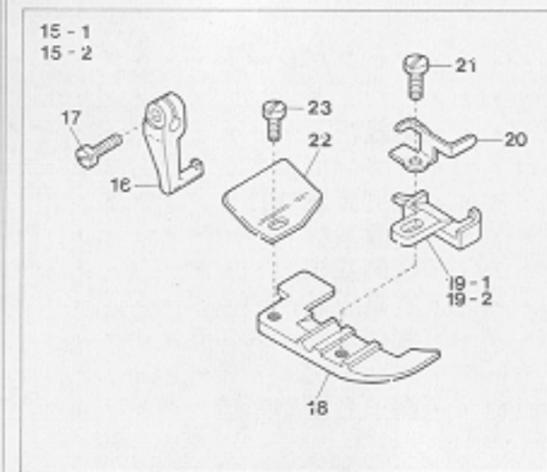

AZ6020H/BT13

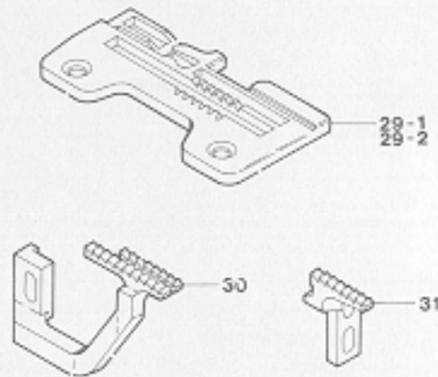
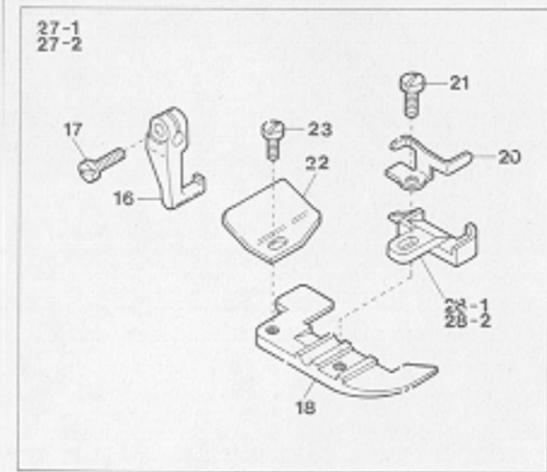

"BT13" DEVICE(2)

Ref. No.	Parts No.	Description	品名	Amt. Req.
1	2101133	Back Tuck Cutting Unit	空糸切り装置(組)	1
2	2101134	Chain-off Cutting Knife Holder	刃取付台	1
3	0023184	Chain-off Cutting Knife	刃	1
4	0023169	Chain-off Cutting Knife Holder Spacer	刃取付台スペーサ	1
5	003637	Screw(1/8-44×2.5)	止ネジ	2
6	004205	Screw(11/64-40×18)	止ネジ	1
7	0024308	Chain-off Holder	空糸押エ	1
8-1	0023182	Chain-off Holder Spring(Standard)	空糸押エパネ(標準)	1
8-2	0033711	" " (with Stronger Pressure)	空糸押エパネ(バネ強い)	1
9	000361	Adjusting Nut	空糸押エパネ調節ナット	2
10	000535	Washer	ワッシャ	1
11	110044	Screw(M3.5-0.6×14)	止ネジ	1
12	0036905	Synchronizer Positioning Pin	ポジションナピン	1
13	110009	Screw(M4-0.7×8)	止ネジ	1
14	0022837	Synchronizer Cushion	ポジションナピンクッション	1
15-1	2107317	Presser Foot, Complete Set(03)	押エ(組)	1
15-2	2107318	" " (04)	"	1
16	0024100	Presser Foot Hinge	押エヒンジ	1
17	004351	Screw(9/64-40×7)	止ネジ	1
18	2107280	Presser Foot(Lower)	押エ(下)	1
19-1	2107224	Presser Foot Stitch Tongue(03)	爪	1
19-2	2107225	" " (04)	"	1
20	2107162	Presser Foot Hinge Spring	押エヒンジバネ	1
21	005036	Screw(1/8-44×5.6)	止ネジ	1
22	0034535	Presser Foot Chain Shield	空糸押エ	1
23	004237	Screw(3/32-56×2.6)	止ネジ	1
24-1	2108011	Stitch Plate(03)	針板	1
24-2	2108008	" (04)	"	1
25	2109010	Differential Feed Dog	前送り	1
26	2109011	Main Feed Dog	後送り	1
27-1	2107319	Presser Foot, Complete Set(X4)	押エ(組)	1
27-2	2107398	" " (X5)	"	1
28-1	2107247	Presser Foot Stitch Tongue(X4)	爪	1
28-2	2107257	" " (X5)	"	1
29-1	2108013	Stitch Plate(X4)	針板	1
29-2	2108119	" (X5)	"	1
30	2109015	Differential Feed Dog	前送り	1
31	2109016	Main Feed Dog	後送り	1

"BT13" DEVICE (3) for AZ6003H

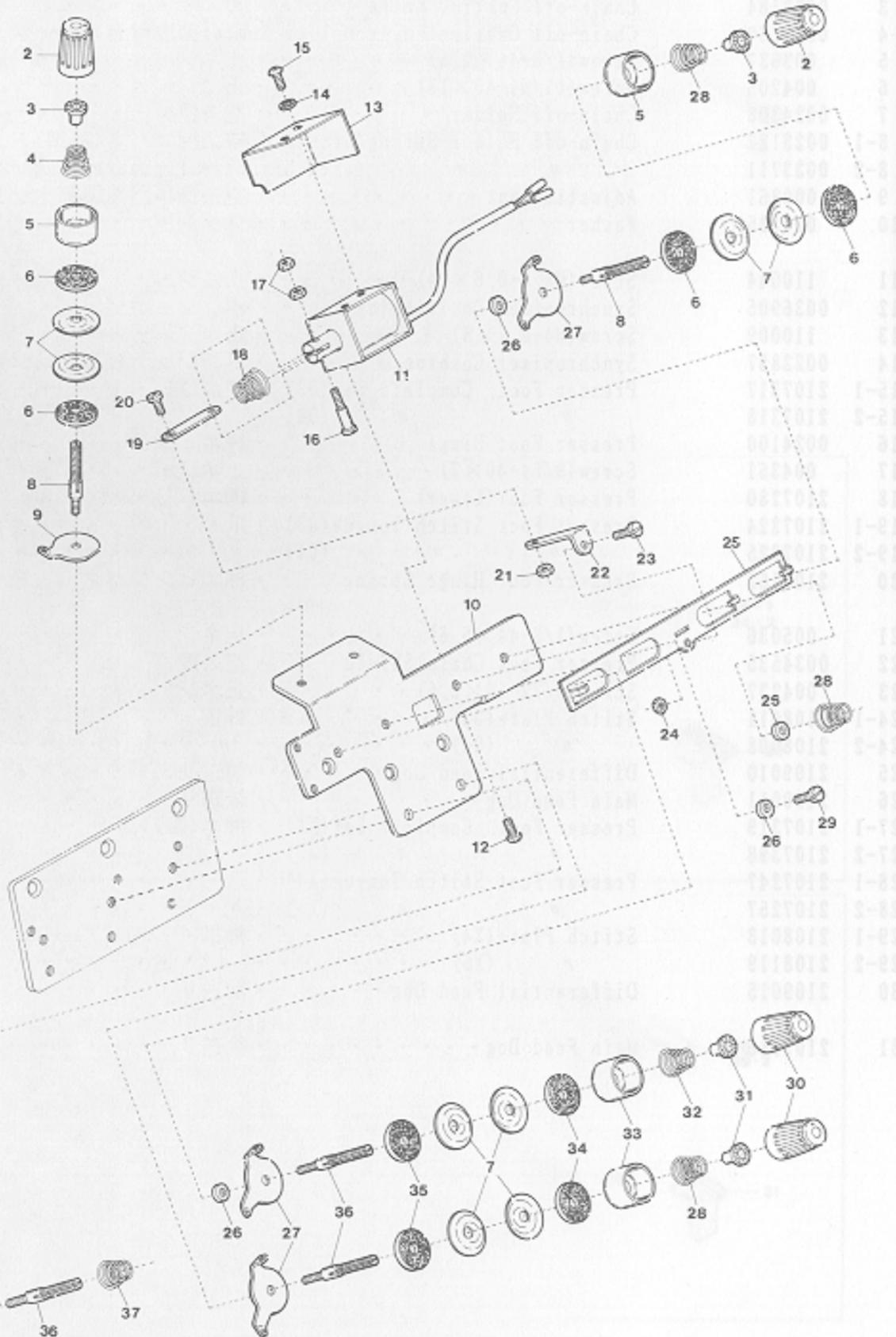

"BT13" DEVICE (3) for AZ6003H

Ref. No.	Parts No.	Description	品名	Amt. Req.
1	2101056	Thread Tension Release, C. Set	糸緩メ装置(組)	1
2	0033806	Thread Tension Spring Cap(G)	糸調子バネキャップ(上)(緑)	3
3	0033890	Thread Tension Spring Bushing	糸調子ナット回り止メ	3
4	0020103	Thread Tension Spring	糸調子バネ	1
5	0033807	Thread Tension Spring Retainer(G)	糸調子バネキャップ(下)(緑)	3
6	000286	Felt(G)	フェルト(緑)	6
7	0031111	Tension Disc	糸調子皿	12
8	007904	Tension Post(Short)	糸調子棒(短)	3
9	0036853	Tension Disc Eyelet	調子台糸道	1
10	0023185	Thread Tension Release Supporting Board	糸緩メ台	1
11	0011839	Thread Tension Release Solenoid	ソレノイド	1
12	009994	Screw(M3-0.5×8)	止ネジ	2
13	0023189	Solenoid Cover	ソレノイドカバー	1
14	000014	Washer	ワッシャ	2
15	009995	Screw(M3-0.5×5)	止ネジ	2
16	005128	Solenoid Connecting Pin	ソレノイド連結ピン	1
17	000021	Nut	ナット	2
18	0032971	Solenoid Spring	ソレノイドバネ	1
19	0023187	Thread Tension Release Link	糸緩メリンク	1
20	006092	Screw(1/8-44×4)	止ネジ	1
21	000330	Nut	ナット	1
22	2101148	Thread Tension Release Plate Guide	糸緩メ板ガイド	1
23	009746	Screw(M4-0.7×8)	止ネジ	1
24	000015	Nut	ナット	1
25	2101329	Thread Tension Release Plate	糸緩メ板	1
26	000496	Spacer	スペーサ	4
27	0020101	Tension Disc Eyelet	調子台糸道	5
28	0024157	Thread Tension Spring	糸調子バネ	3
29	009853	Screw(11/64-40×6.5)	止ネジ	1
30	0024084	Thread Tension Spring Cap(W)	糸調子バネキャップ(上)(白)	3
31	0024083	Thread Tension Spring Bushing	糸調子ナット回り止メ	3
32	0024156	Thread Tension Spring	糸調子バネ	1
33	0020118	Thread Tension Spring Retainer(W)	糸調子バネキャップ(下)(白)	3
34	000178	Felt(W)(2.5mm)	フェルト(白)	3
35	000177	Felt(W)(1.0mm)	フェルト(白)	3
36	007903	Tension Post(Long)	糸調子棒(長)	3
37	0032952	Thread Tension Spring	糸調子バネ	1

Note: (G).....Green colored. (W).....White colored.

(注) (G)は緑色、(W)は白色を表わします。

"BT13"DEVICE(4) for AZ6020H

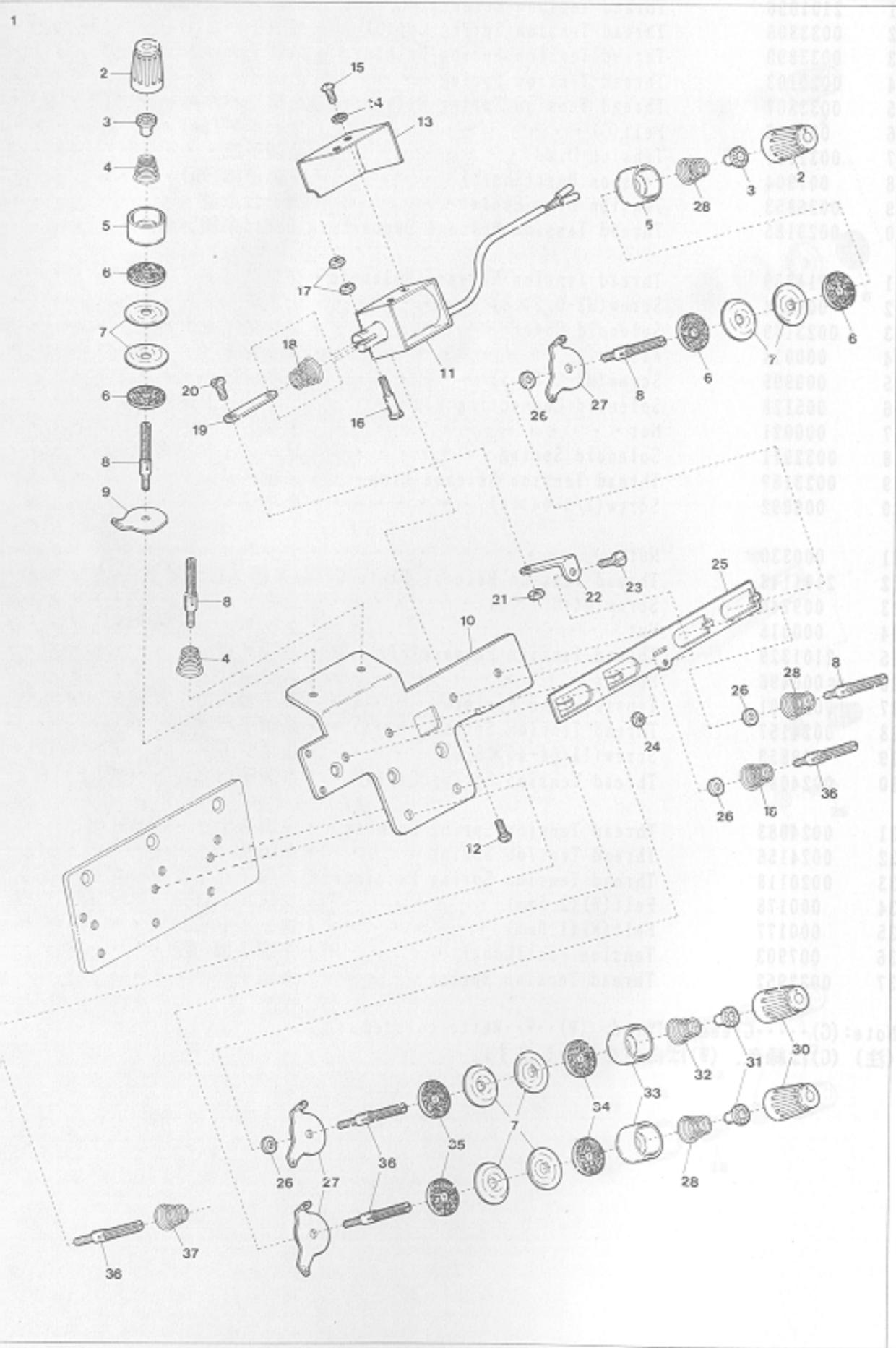

"BT13" DEVICE(4) for AZ6020H

"BT13"装置(4)

Ref. No	Parts No	Description	品名	Amt. Req.
1	2101057	Thread Tension Release, C. Set	糸緩メ装置(組)	1
2	0033806	Thread Tension Spring Cap(G)	糸調子バネキャップ(上)(緑)	4
3	0033890	Thread Tension Spring Bushing	糸調子ナット回り止メ	4
4	0020103	Thread Tension Spring	糸調子バネ	2
5	0033807	Thread Tension Spring Retainer(G)	糸調子バネキャップ(下)(緑)	4
6	000286	Felt(G)	フェルト(緑)	8
7	0031111	Tension Disc	糸調子皿	16
8	007904	Tension Post(Short)	糸調子棒(短)	4
9	0036853	Tension Disc Eyelet	調子台糸道	2
10	0023185	Thread Tension Release Supporting Board	糸緩メ台	1
11	0011839	Thread Tension Release Solenoid	ソレノイド	1
12	009994	Screw(M3-0.5×8)	止ネジ	2
13	0023189	Solenoid Cover	ソレノイドカバー	1
14	000014	Washer	ワッシャ	2
15	009995	Screw(M3-0.5×5)	止ネジ	2
16	005128	Solenoid Connecting Pin	ソレノイド連結ピン	1
17	000021	Nut	ナット	2
18	0032971	Solenoid Spring & Thread Tension Spring	ソレノイドバネ、糸調子バネ	2
19	0023187	Thread Tension Release Link	糸緩メリンク	1
20	006092	Screw(1/8-44×4)	止ネジ	1
21	000330	Nut	ナット	1
22	2101148	Thread Tension Release Guide Plate	糸緩メ板ガイド	1
23	009746	Screw(M4-0.7×8)	止ネジ	1
24	000015	Nut	ナット	1
25	2101330	Thread Tension Release Plate	糸緩メ板	1
26	000496	Spacer	スペーサ	4
27	0020101	Tension Disc Eyelet	調子台糸道	6
28	0024157	Thread Tension Spring	糸調子バネ	3
29				
30	0024084	Thread Tension Spring Cap(W)	糸調子バネキャップ(上)(白)	4
31	0024083	Thread Tension Spring Bushing	糸調子ナット回り止メ	4
32	0024156	Thread Tension Spring	糸調子バネ	1
33	0020118	Thread Tension Spring Retainer(W)	糸調子バネキャップ(下)(白)	4
34	000178	Felt(W)(2.5mm)	フェルト(白)	4
35	000177	Felt(W)(1.0mm)	フェルト(白)	4
36	007903	Tension Post(Long)	糸調子棒(長)	4
37	0032952	Thread Tension Spring	糸調子バネ	1

Note:(G).....Green colored, (W).....White colored.
 (注) (G)は緑色、(W)は白色を表わします。

Ref. No. 44 to 57 See the following page.

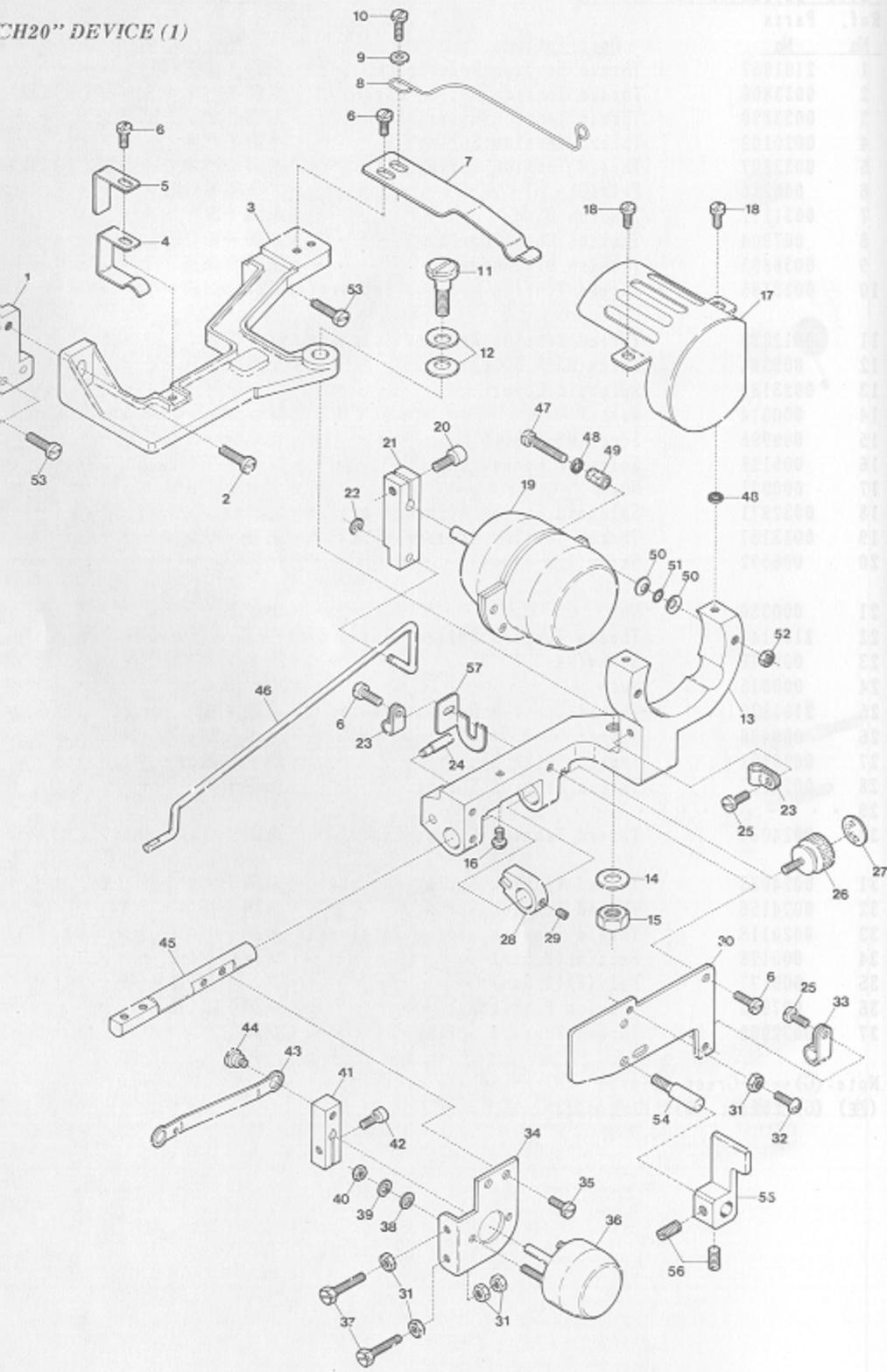

"TC/CH20" DEVICE(1) for AZ6000H

Ref. No.	Parts No.	Description	品名	Amt. Req.
1	0023714	Device Supporting Plate	装置取付板	1
2	009150	Screw(11/64-40×11)	止ネジ	1
3	0023726	Device Holder Base	装置取付台	1
4	0023750	Device Holder Base Fixing Spring Plate	装置取付台固定バネ	1
5	0023763	Supplementary Fixing Spring Plate	補助バネ	1
6	004353	Screw(9/64-40×7)	止ネジ	5
7	0023715	Solenoid Holder Fixing Spring Plate	ソレノイド取付台固定バネ	1
8	0023769	Fixing Spring	定規連結軸固定バネ	1
9	000533	Washer	ワッシャ	1
10	001175	Screw(9/64-40×8)	止ネジ	1
11	005589	Screw(1/4-40×14.5)	止ネジ	1
12	000621	Conical Spring Washer	皿バネワッシャ	2
13	0023725	Solenoid Holder	ソレノイド取付台	1
14	000613	Washer	ワッシャ	1
15	000306	Nut	ナット	1
16	001333	Stop Screw(3/32-56×3.9)	ストップネジ	1
17	0026470	Rotary Solenoid Cover	ロータリソレノイドカバー	1
18	005000	Screw(9/64-40×5.7)	止ネジ	2
19	0011190	Rotary Solenoid(Large)	ロータリソレノイド(大)	1
20	005550	Screw(11/64-40×13.5)	止ネジ	1
21	0036111	Hemming Guide Interlocking Lever	定規連動レバー	1
22	0036132	Retaining Ring	ストップリング	1
23	0094491	Cord Clamp(φ3.4-2N)	コードクランプ	2
24	0023711	Guide Pin	ガイドピン	1
25	004358	Screw(9/64-40×5.6)	止ネジ	2
26	005585	Adjusting Screw(11/64-40×10)	調節ネジ	1
27	001049	Sticker	貼リマーク	1
28	0023723	Guide Collar	ガイドカラー	1
29	003638	Screw(11/64-40×4)	止ネジ	1
30	0023717	Solenoid Holder Cover	ソレノイド取付台カバー	1
31	000335	Lock Nut	ロックナット	5
32	001326	Positioning Screw(9/64-40×7.5)	位置決メネジ	1
33	0036133	Cord Clamp(φ8.4-5N)	コードクランプ	1
34	0023722	Solenoid Supporting Plate	ソレノイド取付板	1
35	004406	Screw(11/64-40×8)	止ネジ	2
36	0011191	Rotary Solenoid(Small)	ロータリソレノイド(小)	1
37	007606	Adjusting Screw(9/64-40×20)	調節ネジ	2
38	000014	Washer	ワッシャ	2
39	000002	Spring Washer	スプリングワッシャ	2
40	000012	Nut	ナット	2

※ Ref. No. 41 to 57 See the following page.

"TC/CH20"装置(1)

"TC/CH20" DEVICE(1) for AZ6000H

Ref. No.	Parts No.	Description	品名	Amt. Req.
41	0023718	Edge Guide Interlocking Lever	スライド定規レバー	1
42	005038	Screw(11/64-40×8)	止ネジ	1
43	0023712	Edge Guide Interlocking Plate	スライド定規連結板	1
44	005588	Screw(11/64-40×2.1)	止ネジ	1
45	0023713	Edge Guide Holding Shaft	定規台取付軸	1
46	0023709	Hemming Guide Interlocking Shaft	定規連結軸	1
47	009931	Screw(11/64-40×26)	止ネジ	2
48	000550	Fiber Cushion	防振ファイバ	4
49	0023799	Cushion(Vinyl)	ソレノイドクッション	2
50	000010	Conical Spring Washer	皿バネワッシャ	4
51	0020539	Rubber Cushion	防振ゴム	2
52	000334	Nut	ナット	2
53	110047	Screw(M4-0.7×10)	止ネジ	3
54	280000	Screw Pin(11/64-40×12)	ピンネジ	1
55	2110327	Adjusting Lever	調節レバー	1
56	160001	Screw(M4-0.7×4)	止ネジ	2
57	2101038	Adjusting Screw Guide	調節ネジガイド	1

※ Ref. No. 1 to 40 See the preceding page.



(注) カラーの寸法は内径×外径×厚さを表しています。
 Note: Size of Collar ... Inside dia. × Outside dia. × Thickness

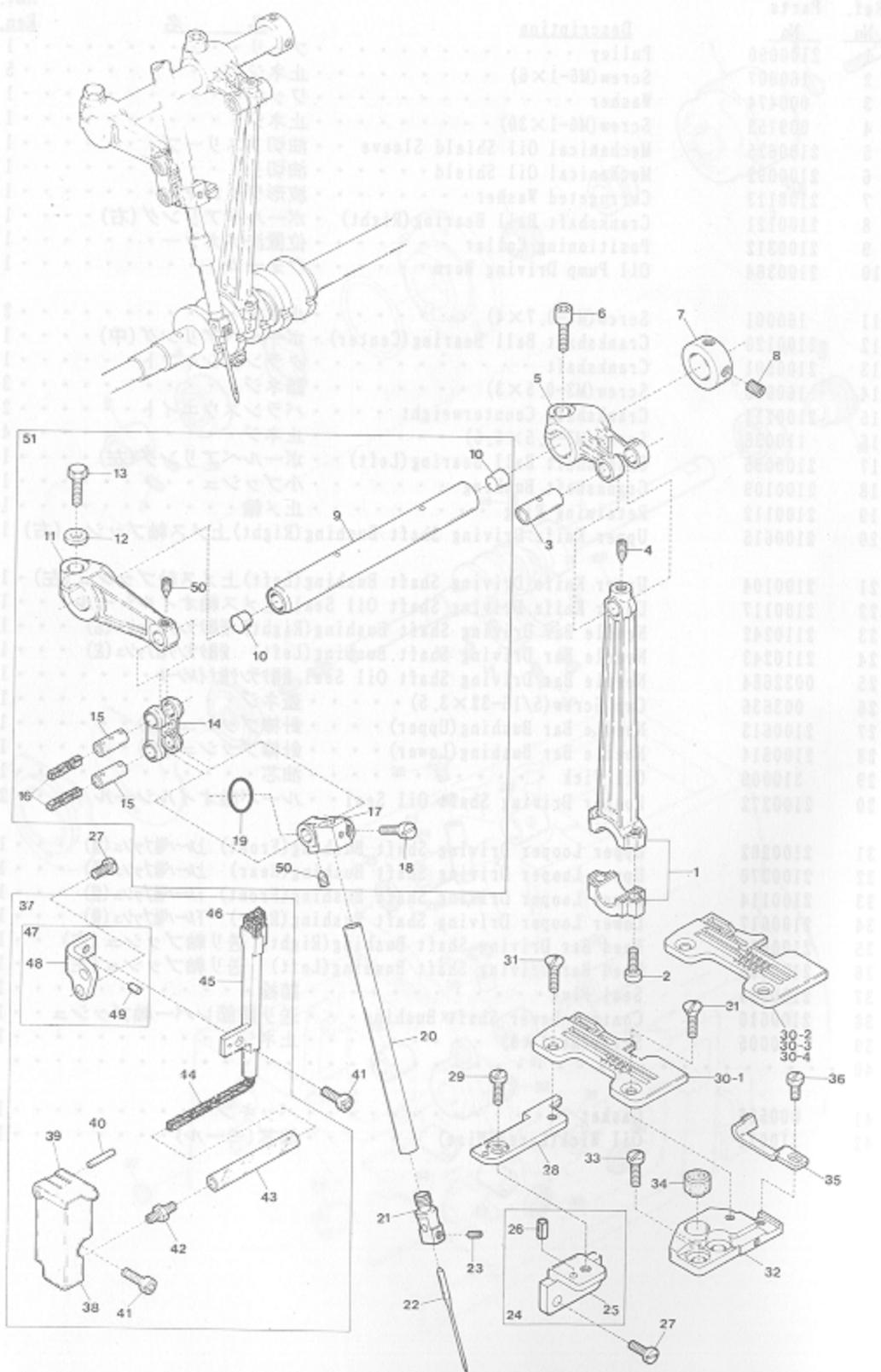

NEEDLE BAR DRIVING MECHANISM

Ref. No.	Parts No.	Description	品名	Amt. Req.
1	2100132	Needle Bar Driving Connecting Rod	針棒ロッド	1
2	120001	Screw(M4-0.7×14)	止ネジ	2
3	2100144	Needle Bar Driving Connecting Rod Pin	針棒クランクピン	1
4	160002	Screw(M4-0.7×5)	止ネジ	1
5	2100134	Needle Bar Driving Lever	針棒クランク軸腕	1
6	120006	Screw(M6-1×12)	止ネジ	1
7	2100137	Collar(12×20×10mm)	針棒クランク軸カラー	1
8	160003	Screw(M5-0.8×5)	止ネジ	2
9	2100540	Needle Bar Driving Shaft	針棒クランク軸	1
10	330006	Seal Plug	詰栓	2
11	2100136	Needle Bar Crank Arm	針棒クランク	1
12	300008	Washer	ワッシャー	1
13	140003	Screw(M6-1×18)	止ネジ	1
14	2100138	Needle Bar Connecting Link	針棒リンク	1
15	2100620	Needle Bar Connecting Link Pin	針棒リンクピン	2
16	310051	Oil Wick	油芯	2
17	2100140	Needle Bar Connecting Bracket	針棒抱キ	1
18	110006	Screw(M3.5-0.6×10)	止ネジ	1
19	0068079	O-ring(P9)	Oリング	1
20	0037372	Needle Bar	針棒	1
21	2109132	Needle Clamp	針止メ	1
22	---	Needle(System:DC×1)	針	1
23	003637	Screw(1/8-44×2.5)	止ネジ	1
24	2100503	Stitch Plate Support Stay, C. Set	針板取付台支エ(組)	1
25	2100504	Stitch Plate Support Stay	針板取付台支エ	1
26	000035	Roll Pin	ロールピン	1
27	110009	Screw(M4-0.7×8)	止ネジ	4
28	2100502	Stitch Plate Support(Rear)	針板取付台(後)	1
29	110001	Screw(M4-0.7×5.4)	止ネジ	1
30-1	2108002	Stitch Plate(03)	針板(03)	1
30-2	2108003	" (04)	" (04)	1
30-3	2108007	" (05)	" (05)	1
30-4	2108012	" (06)	" (06)	1
31	005345	Screw(11/64-40×8.3)	止ネジ	2
32	2100145	Stitch Plate Support(Front)	針板取付台(前)	1
33	110011	Screw(M5-0.8×10)	止ネジ	2
34	0032604	Rubber Cushion	埋メ座	1
35	2109200	Needle Guard(Front)	針受ケ(前)	1
36	110002	Screw(M3-0.5×5)	止ネジ	1
37	2100532	HR Unit, Complete Set	HR装置(組)	1
38	2100148	HR Cup	HRカップ	1
39	0033968	HR Cup Lid	HRカップ蓋	1
40	000693	Pin	ピン	1

※ Ref. No. 41 to 51 See the following page.

(注) カラーの寸法は内径×外径×幅を表しています。
 Note: Size of Collar ... Inside dia.×Outside dia.×Thickness

NEEDLE BAR DRIVING MECHANISM

Ref. No.	Parts No.	Description	品名	Amt. Req.
41	110013	Screw(M4-0.7×8)	止ネジ	2
42	009909	Tube Joint	パイプ継手	1
43	2100152	Oil Tube(70mm)	給油パイプ(70mm)	1
44	310005	Oil Wick	油芯	1
45	2100533	HR Felt Holder	HRフェルト受ケ	1
46	310001	HR Felt	HRフェルト	1
47	2100535	HR Felt Holder Bracket, C. Set	HR取付台(組)	1
48	2100536	HR Felt Holder Bracket	HR取付台	1
49	000293	Roll Pin	ロールピン	1
50	160016	Screw(M4-0.7×4.5)	止ネジ	2
51	2100621	Needle Bar Crank Arm, C. Set	針棒クランク(組)	1

※ Ref. No. 1 to 40 See the preceding page.

20" DEVICE (2)

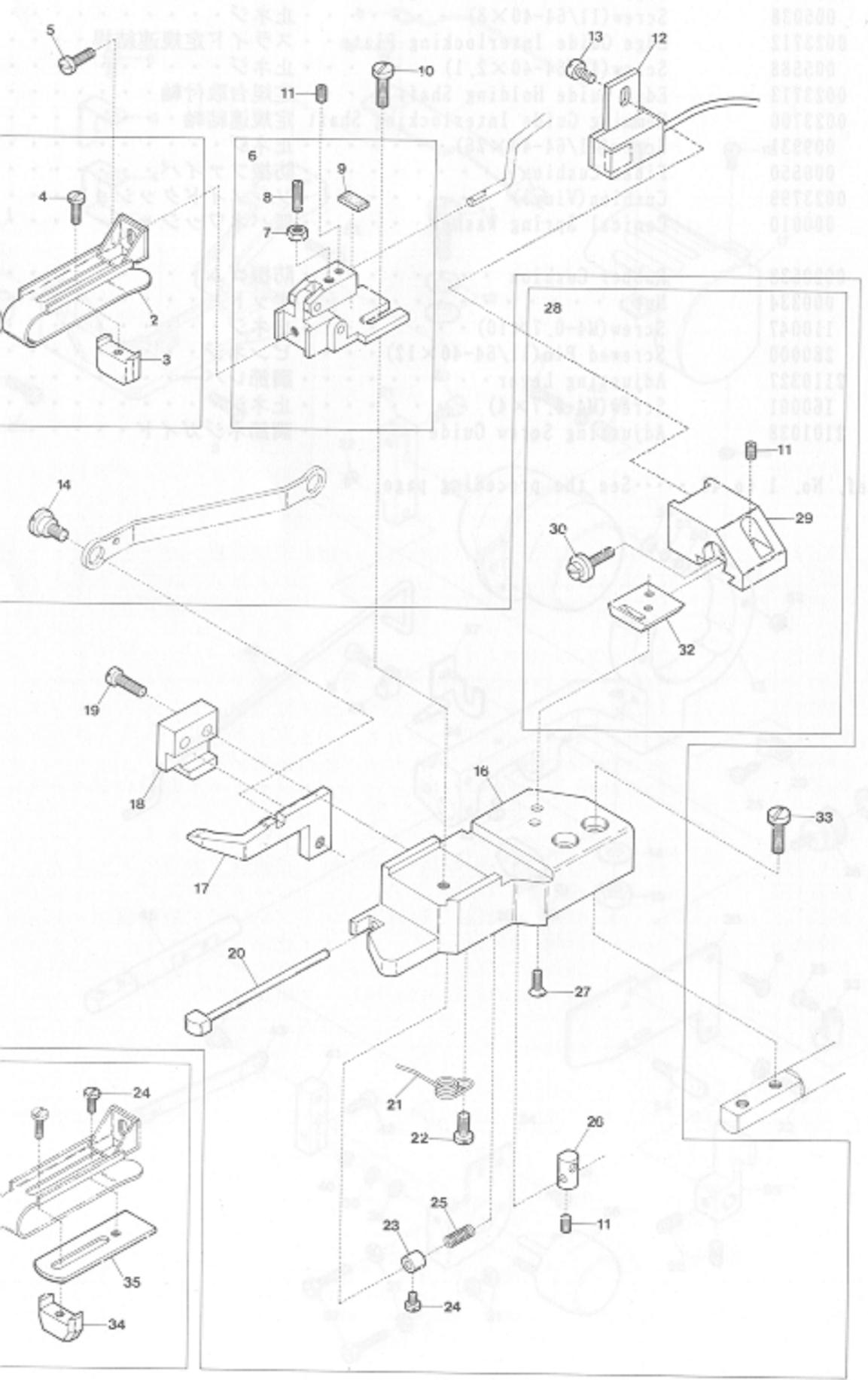

"TC/CH20" DEVICE(2) for A26000H

"TC/CH20"装置(2)

60
Amt.
Req.

Ref. No.	Parts No.	Description	品名	Req.
1	0023740	Blind-Hemming Guide, Complete Set	定規(組)	1
2	0023739	Blind-Hemming Guide	定規	1
3	0023741	Hemming Positioner	裾引幅調節片	1
4	004236	Screw(3/32-56×4.2)	止ネジ	1
5	005036	Screw(1/8-44×5.6)	止ネジ	1
6	0023744	Hemming Guide Bracket, C. Set	定規調節台(組)	1
7	000335	Lock Nut	ロックナット	1
8	006820	Adjusting Screw(9/64-40×12.3)	調節ネジ	1
9	0036161	Anti-shock Rubber	定規緩衝ゴム	1
10	001202	Screw(9/64-40×6.6)	止ネジ	1
11	003637	Screw(1/8-44×2.5)	止ネジ	3
12	1200182	Side Seam Detector Unit	ホールIC(組)	1
13	005036	Screw(1/8-44×5.6)	止ネジ	1
14	005588	Screw(11/64-40×2.1)	止ネジ	1
15	0023747	Blind-Hemming Edge Guide, C. Set	定規台(組)	1
16	0023724	Blind-Hemming Edge Guide	定規台	1
17	0023707	Slide Edge Guide	スライド定規	1
18	0023705	Slide Edge Guide Holder	スライド定規受け	1
19	007609	Screw(9/64-40×9)	止ネジ	2
20	0023708	Sensor	感知子	1
21	0023737	Slide Edge Guide Pressing Spring	スライド定規戻シバネ	1
22	005000	Screw(9/64-40×5.7)	止ネジ	1
23	0023709	Collar(2×5×5mm)	感知子調節カラー	1
24	004237	Screw(3/32-56×2.6)	止ネジ	2
25	0023710	Sensor Spring	感知子戻シバネ	1
26	0023756	Magnet Unit	マグネット(組)	1
27	001613	Screw(3/32-56×4.5)	止ネジ	2
28	2101394	IC Positioner, Complete Set	IC調節台(組)	1
29	2101395	IC Positioner	IC調節台	1
30	005591	Adjusting Screw(1/8-44×6.2)	調節ネジ	1
31				
32	0023703	Raterally Sliding Plate	左右スライド板	1
33	004440	Screw(11/64-40×8.3)	止ネジ	2
34	0023767	Hemming Positioner(for Light Materials)	裾引幅調節片(薄物用)	1
35	0023768	Spacer(for Light Materials)	定規スペーサ(薄物用)	1

(注) カラーの寸法は内径×外径×幅を表しています。
 Note: Size of Collar ... Inside dia. × Outside dia. × Thickness

"CH20" DEVICE(3)

"TC" DEVICE

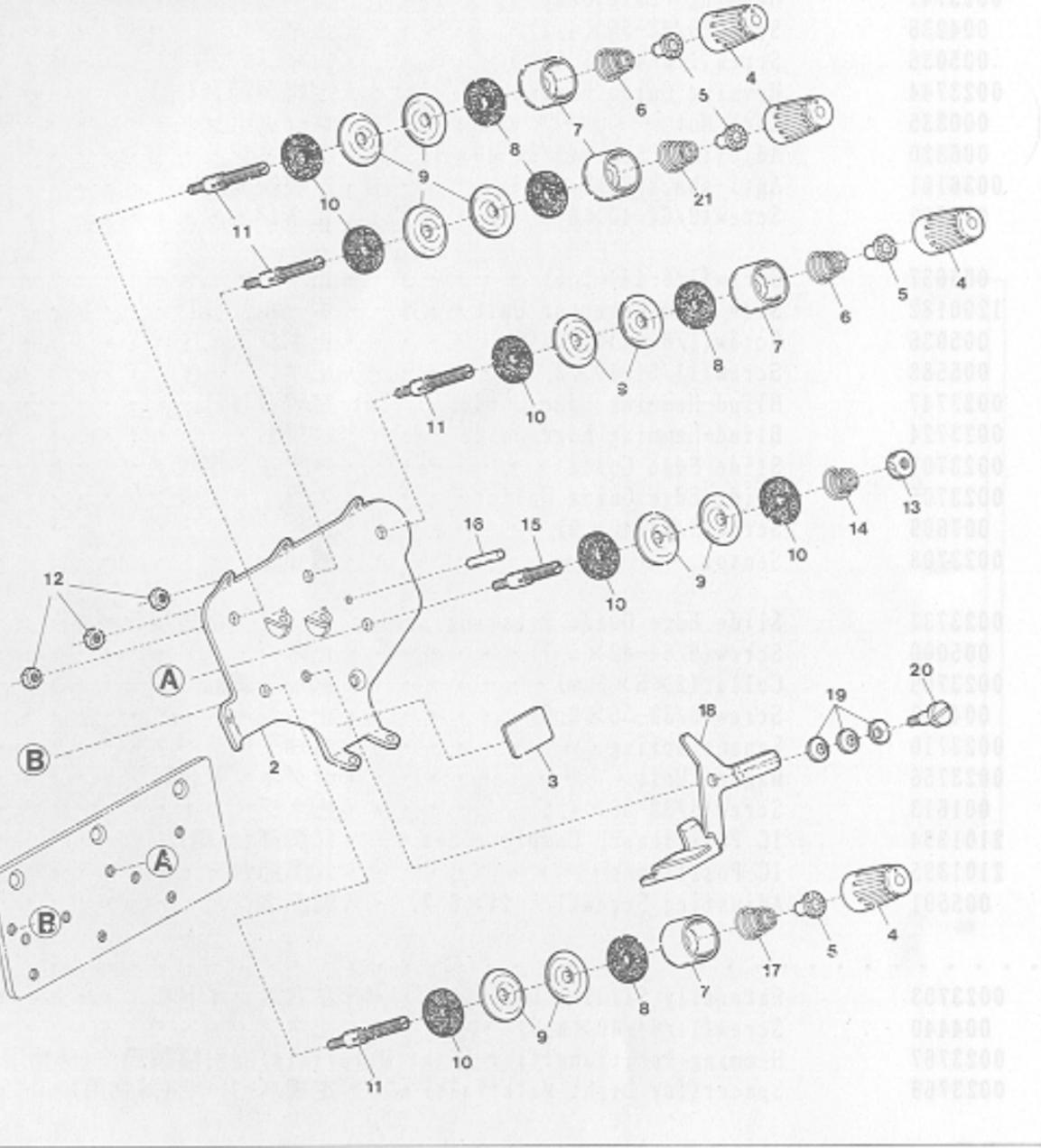

"TC/CH20" DEVICE(3) for AZ6000H

"TC/CH20"装置(3)

Ref. No.	Parts No.	Description	品名	Amt. Req.
1	0026467	Tension Change Device, C. Set	"TC"装置(組)	1
2	0026466	Thread Tension Disc Eyelet	調子台糸道	1
3	000622	Sticker	貼りマーク	1
4	0024084	Thread Tension Spring Cap	糸調子バネキャップ(上)	4
5	0024083	Thread Tension Spring Bushing	糸調子ナット回り止メ	4
6	0024157	Thread Tension Spring	糸調子バネ	2
7	0020118	Thread Tension Spring Retainer	糸調子バネキャップ(下)	4
8	000178	Felt	フェルト	4
9	0031111	Tension Disc	糸調子皿	10
10	000177	Felt	フェルト	6
11	007903	Tension Post	糸調子棒	4
12	000334	Nut	ナット	3
13	000056	Adjusting Nut	調節ナット	1
14	0037114	Thread Tension Spring	糸調子バネ	1
15	001904	Tension Post	糸調子棒	1
16	0023766	Thread Guide Pin	糸ガイドピン	1
17	0024156	Thread Tension Spring	糸調子バネ	1
18	0023728	Tension Change Lever	TCレバー	1
19	000010	Conical Spring Washer	皿バネワッシャ	3
20	004100	Screw(11/64-40×3.2)	止ネジ	1
21	0032952	Thread Tension Spring	糸調子バネ	1

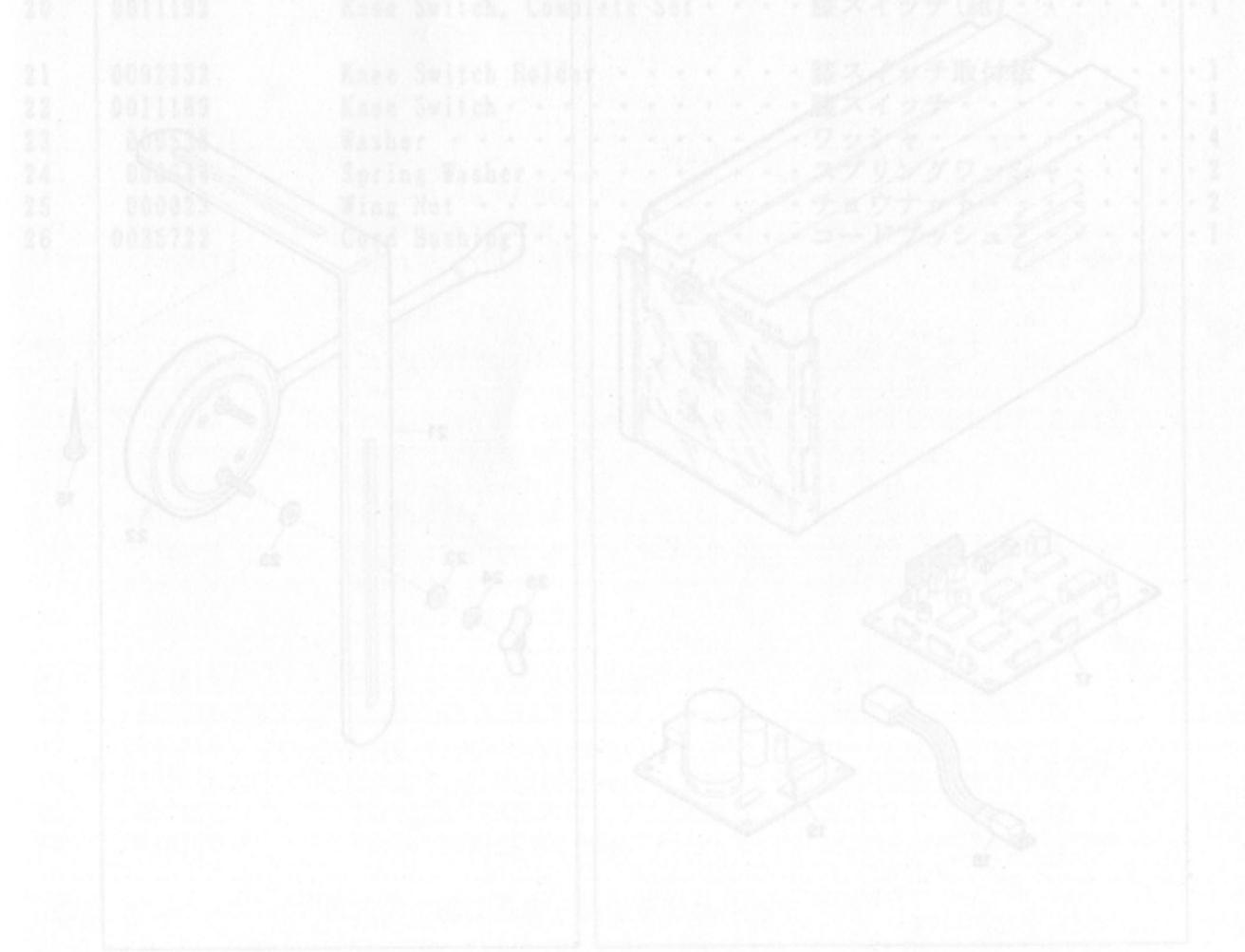

"CH20" DEVICE(4)

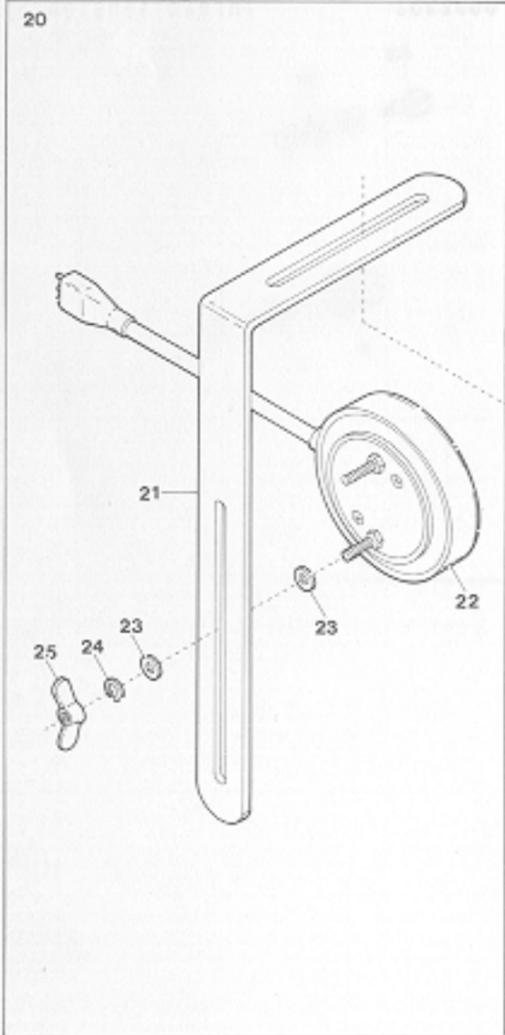
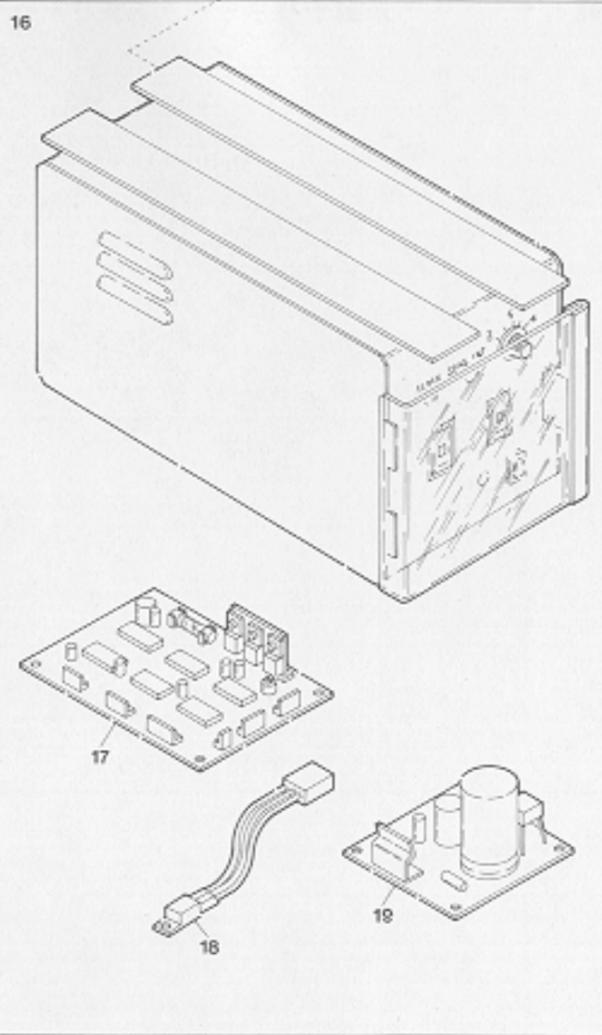
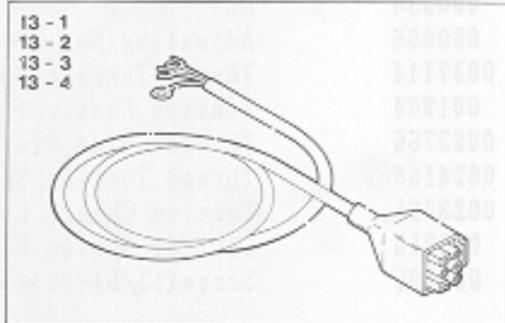
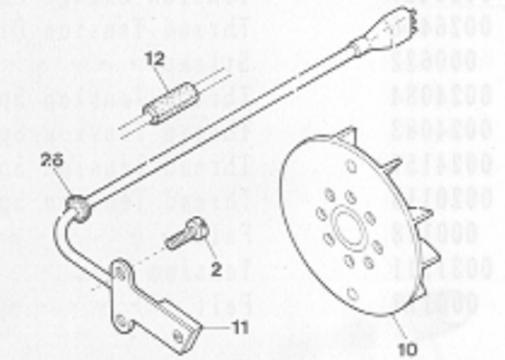
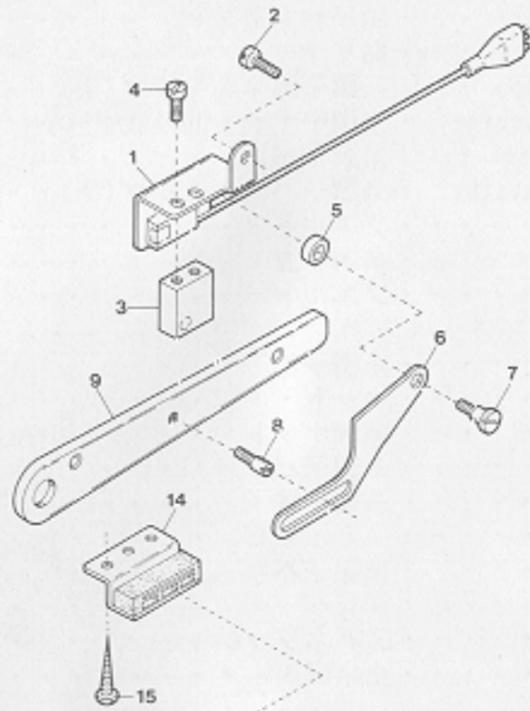

"TC/CH20" DEVICE(4) for AZ6000H

"TC/CH20"装置(4)

Ref. No.	Parts No.	Description	品名	Amt. Req.
1	1200006	Presser Foot Switch Unit	押エスイッチ(組)	1
2	110013	Screw(M4-0.7×8)	止ネジ	3
3	0023734	Magnet for Presser Foot Switch	マグネット	1
4	004353	Screw(9/64-40×7)	止ネジ	2
5	0023720	Switch Plate Spacer	スイッチ板スペーサ	1
6	2121021	Switch Plate	スイッチ板	1
7	005587	Screw(9/64-40×8.6)	止ネジ	1
8	005512	Guide Screw(11/64-40×3)	ガイドネジ	1
9	2101040	Presser Foot Lifter Lever	押エ揚グレバー	1
10	2101043	Oil Cooling Fan Magnet Unit	ファンマグネット(組)	1
11	1200001	Rotation Detector Unit	ホールIC(組)	1
12	2101124	Cord Bushing	コードブッシュ	1
13-1	0011943	Power Cord(for 100 Voltage)	電源コード(100V用)	1
13-2	0011944	" (" 200 ")	" (200")	1
13-3	0011945	" (" 220 ")	" (220")	1
13-4	0011946	" (" 380 ")	" (380")	1
14	0011709	Control Box Stay	制御ボックスステイ	2
15	006910	Wood Screw(φ6.8×26)	木ネジ	10
16	0011180	Control Box, Complete Set	制御装置(組)	1
17	0011182	Control Board	CH制御基板	1
18	0011974	Voltage Regulator	定電圧IC	1
19	0011183	Power Board	CH電源基板	1
20	0011192	Knee Switch, Complete Set	膝スイッチ(組)	1
21	0092232	Knee Switch Holder	膝スイッチ取付板	1
22	0011189	Knee Switch	膝スイッチ	1
23	000538	Washer	ワッシャ	4
24	000644	Spring Washer	スプリングワッシャ	2
25	000023	Wing Nut	チョウナット	2
26	0035722	Cord Bushing	コードブッシュ	1

(注) ビニールパイプ類注文の際は品番と長さをお知らせ下さい。
 Note: Is for Vinyl Tube, your order must be accompanied with size and length.

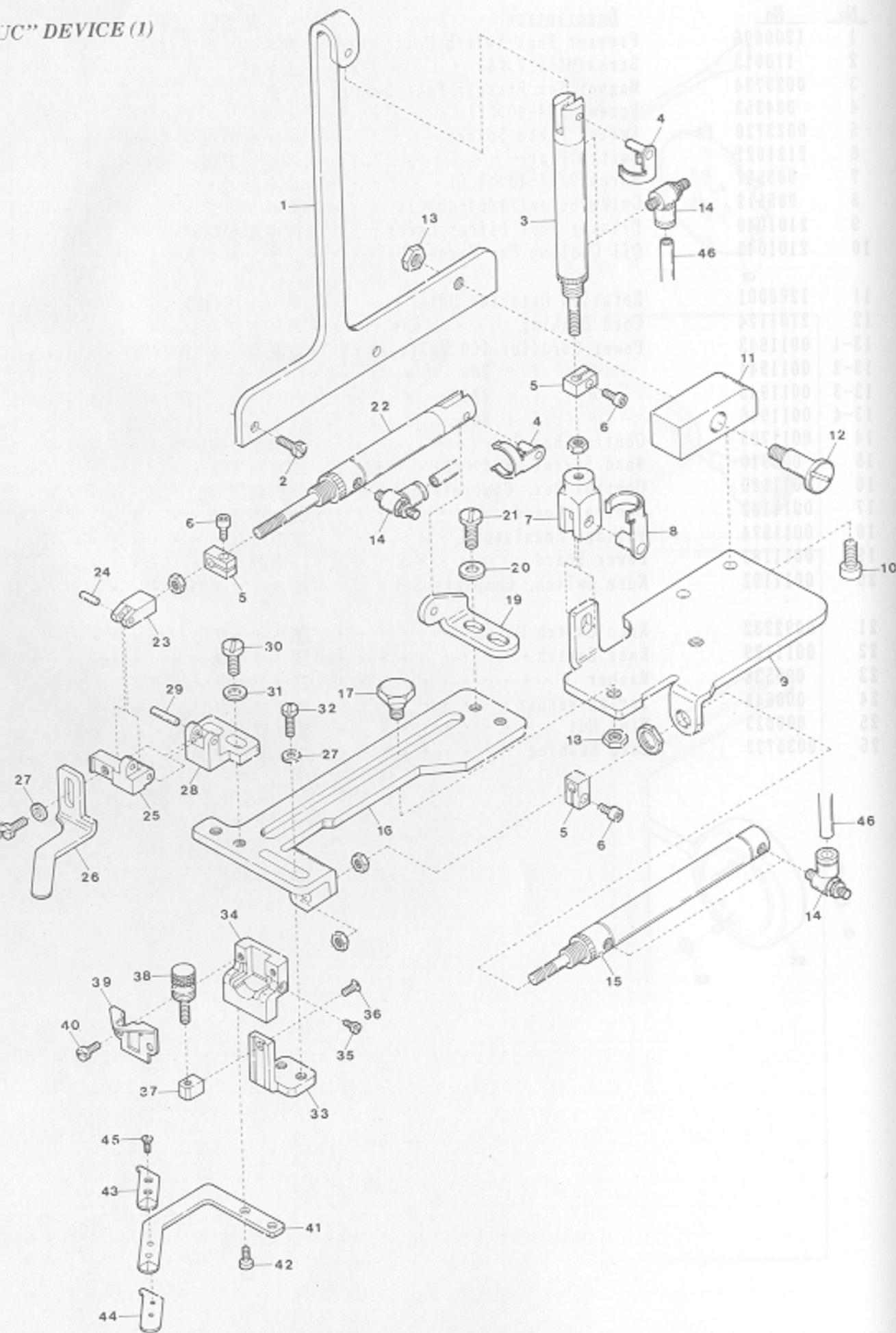

“UC” DEVICE (1)

Ref. No	Parts No	Description	品名	Amt. Req.
1	2101600	Cylinder Support (Vertical)	シリンダ取付板(縦)	1
2	110009	Screw (M4-0.7×8)	止ネジ	3
3	0010327	Cylinder (MS10-PD-30)	シリンダ	1
4	0010287	Cylinder Joint Pin	ピン金具	2
5	0013085	Cylinder Collar	カラー	3
6	005037	Screw (9/64-40×8)	止ネジ	3
7	2101616	Y-Knuckle	Yナックル	1
8	1255174	Cylinder Joint Pin	ピン金具	1
9	2101602	Cylinder Holder (Large)	シリンダ取付台(大)	1
10	005650	Screw (M5-0.8×14)	止ネジ	2
11	2101601	Cylinder Holder Block	シリンダ取付台ブロック	1
12	004103	Screw (1/4-40×8)	止ネジ	1
13	000419	Nut	ナット	1
14	1095001	Speed Controller (AS1201F-M5-04)	スピードコントローラ	5
15	1091025	Cylinder (MS-10-ND-60-P)	シリンダ	1
16	2101603	Slider	左右スライダ	1
17	006188	Screw (M6-1×8)	止ネジ	2
18	000011	Nut	ナット	2
19	2101604	Cylinder Holder (Small)	シリンダ取付台(小)	1
20	300000	Washer	ワッシャ	2
21	110103	Screw (M5-0.8×8)	止ネジ	2
22	1091071	Cylinder (MS-10-PRS-20)	シリンダ	1
23	2101607	Uncurling Plate (Upper) Connector	連結軸継手	1
24	0036092	Connecting Pin	連結ピン	1
25	2101606	Uncurling Plate (Upper) Bracket	カール防止板(上)取付片	1
26	2101608	Uncurling Plate (Upper)	カール防止板(上)	1
27	000665	Washer	ワッシャ	3
28	2101605	Adjusting Block	カール防止調節台	1
29	0036091	Connecting Pin	連結ピン	1
30	110011	Screw (M5-0.8×10)	止ネジ	2
31	000669	Washer	ワッシャ	2
32	110035	Screw (M4-0.7×10)	止ネジ	2
33	2101613	Uncurling Plate (Lower) Adjuster	カール防止板(下)調節台	1
34	2101612	Uncurling Plate (Lower) Bracket	カール防止板(下)取付台	1
35	009624	Screw (1/8-44×5.3)	止ネジ	1
36	007619	Screw (9/64-40×6.3)	止ネジ	1
37	0022443	Adjusting Screw Guide Piece	調節ネジガイド	1
38	006444	Adjusting Screw (1/8-44×12.9)	調節ネジ	1
39	0022444	Bracket Cover	取付台蓋	1
40	001196	Screw (1/8-44×6)	止ネジ	2
41	2101609	Uncurling Plate (Lower)	カール防止板(下)	1
42	009779	Screw (M3-0.5×6)	止ネジ	2
43	2101610	Uncurling Chip (Upper)	カール防止チップ(上)	1
44	2101611	Uncurling Chip (Lower)	カール防止チップ(下)	1
45	005112	Screw (3/32-56×6)	止ネジ	2
46	0010260	Vinyl Tube (4×2.5mm)	ビニールパイプ	-

(注) ビニールパイプ御注文の際は品番と長さをお知らせ下さい。
 Note: As for Vinyl Tube, your order must be accompanied with No. and length.

"C" DEVICE (2)

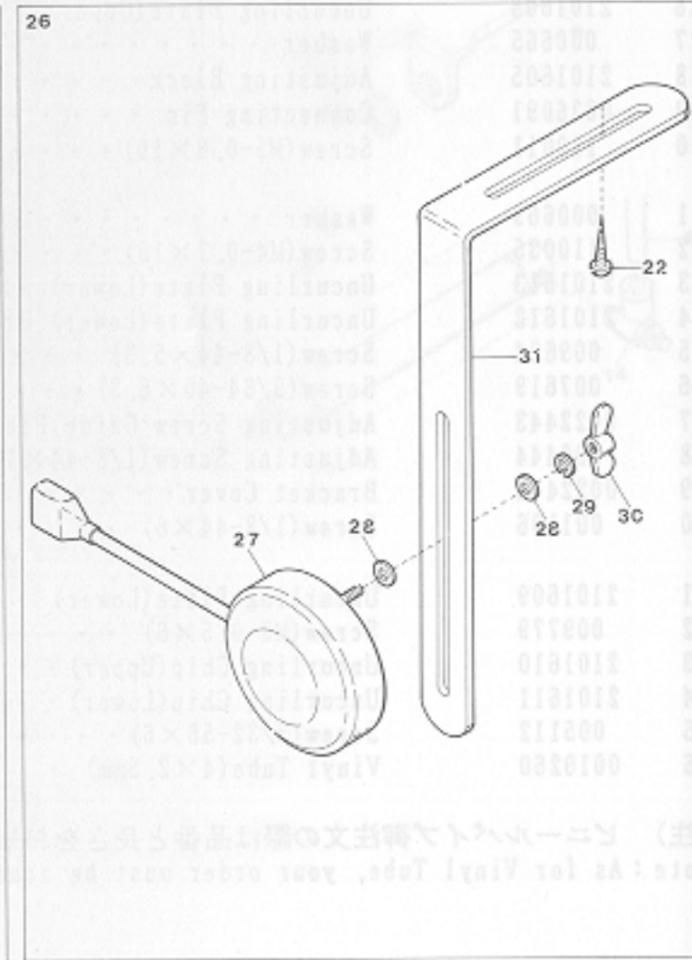
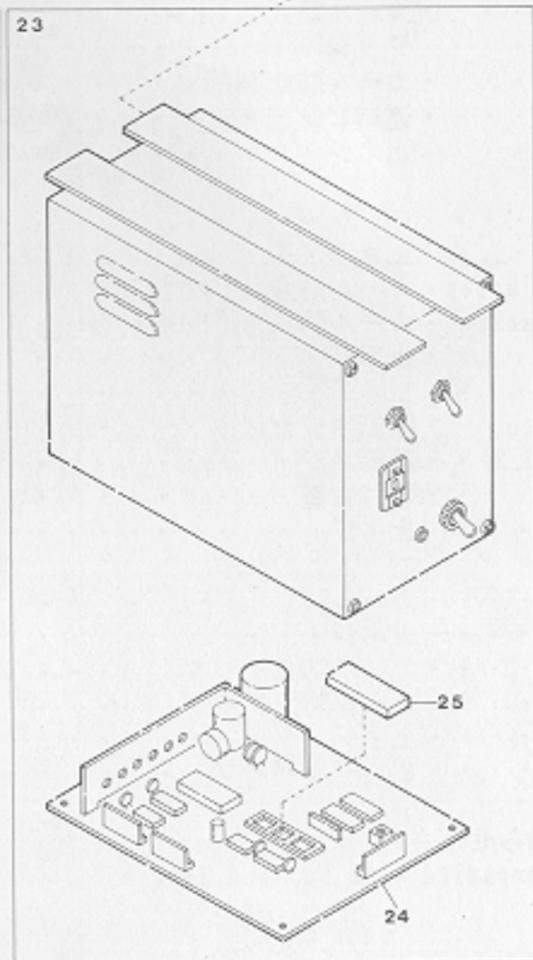
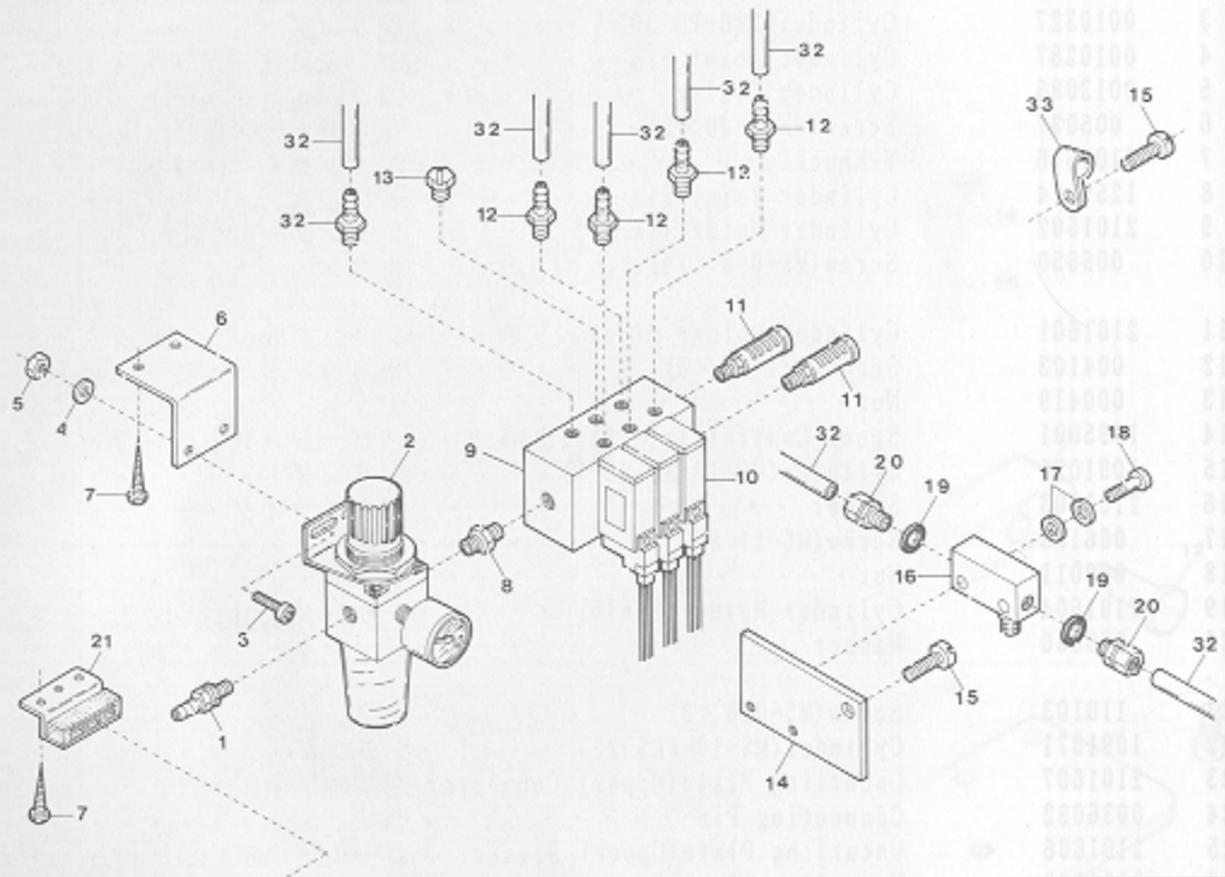

"UC" DEVICE (2)

Ref. No.	Parts No.
1	0010108
2	0010073
3	009960
4	000669
5	000009
6	0013218
7	006905
8	1094017
9	1090038
10	1090035
11	0010143
12	0010018
13	1094009
14	1260062
15	110013
16	0010054
17	000014
18	009993
19	000623
20	0010258
21	0011709
22	006910
23	1249031
24	1057050
25	1050027
26	0011883
27	0011882
28	000538
29	000644
30	000023
31	0092232
32	0010260
33	0036133

Description

Description	品名	Amt. Req.
Hose Joint (φ8-PT 1/4)	ホースユニオン	1
Regulator	レギュレータ	1
Screw (M5-0.8×16)	止ネジ	2
Washer	ワッシャ	2
Nut	ナット	2
Regulator Support	レギュレータ取付板	1
Wood Screw (φ5.1×20)	木ネジ	10
Nipple	ニップル	1
Manifold (VV5J3-S41-3-M5)	マニフォルド	1
Electromagnetic Valve (5 Port)	電磁弁 (5方口)	3
Silencer (MF-6)	サイレンサ	2
Bamboo Joint (M5-4×2.5)	bambu継手	5
Seal Plug	メクラプラグ	1
Speed Controller Support	スピードコントローラ取付板	1
Screw (M4-0.7×8)	止ネジ	2
Speed Controller (SP-01-M5)	スピードコントローラ	1
Washer	ワッシャ	4
Screw (M3-0.5×16)	止ネジ	2
Gasket	パッキン	2
Connector (M5-4×2.5)	継手	2
Control Box Stay	制御ボックスステイ	4
Wood Screw (φ6.8×26)	木ネジ	2
Control Box, Complete Set	制御装置 (組)	1
Control Board	制御基板	1
Single Chip Micro Computer	マイコン	1
Knee Switch, Complete Set	膝スイッチ (組)	1
Knee Switch	膝スイッチ	1
Washer	ワッシャ	4
Spring Washer	スプリングワッシャ	2
Wing Nut	チョウナット	2
Knee Switch Holder	スイッチ取付板	1
Vinyl Tube (4×2.5mm)	ビニールパイプ	-
Cord Clamp (φ8.4-5N)	コードクランプ	1

(注) ビニールパイプ御注文の際は品番と長さをお知らせ下さい。
 Note: As for Vinyl Tube, your order must be accompanied with No. and length.

"UC"装置 (2)

"UC"DEVICE(3)

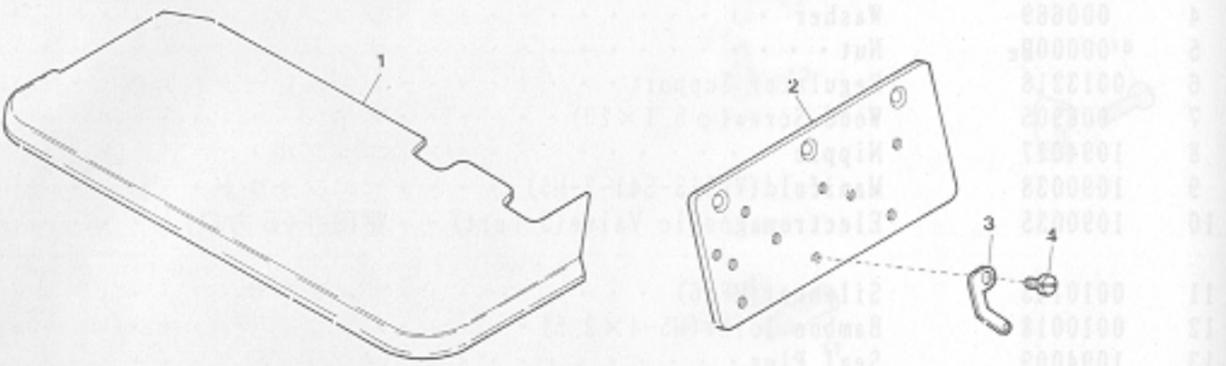

Ref. No.	Parts No.	Description	Amt.	Req.
1	0018108	Hose Joint (ø 5-5)	1	
2	0010073	Regulator	1	
3	0008880	Screw (M3-0.5x10)	3	
4	0008889	Washer	4	
5	0000008	Nut	5	
6	0013218	Return Spring (Large)	1	
7	0003005	Air Valve Support	1	
8	0008887	Air Valve Support	1	
9	0008888	Air Valve Support	1	
10	0008885	Air Valve Support	1	
11	0010017	Bamboo Joint (ø 5-5x4)	1	
12	0008881	Gasket	1	
13	0008889	Seal Ring	1	
14	0008882	Speed Controller (2 part)	1	
15	0008883	Speed Controller (2 part)	1	
16	0008884	Speed Controller (2 part)	1	
17	0008886	Washer	1	
18	0008887	Screw (M3-0.5x10)	1	
19	0008888	Gasket	1	
20	0008889	Connector (ø 5-5x2.5)	1	
21	0011788	Control Box Step	1	
22	0008810	Wood Screw (ø 5x10)	1	
23	0008811	Control Box (Composite)	1	
24	0008812	Control Board	1	
25	0008813	Single Clip Micro Switch	1	
26	0008814	Micro Switch	1	
27	0008815	Micro Switch	1	
28	0008816	Washer	1	
29	0008817	Spring Washer	1	
30	0008818	Wing Nut	1	
31	0008819	Knee Switch Holder	1	
32	0008820	Vinyl Tubing (ø 4-5mm)	1	
33	0008821	Cord Clamp (ø 4-5mm)	1	

(注) ニースイッチの取付文は別紙を参照してください。
 Note: As for Vinyl Tube, your order must be accurate.

"UC" DEVICE (3)

Ref. No.	Parts No.	Description	品名	Amt.	Req.
1	2101614	Cloth Plate	クロスプレート	1	
2	2101615	Tension Disc Eyelet Support	調子台糸道取付板	1	
3	2100537	Upper Looer Supplementary Thread Eyelet	上ルーパ補助糸道	1	
4	009853	Screw (11/64-40x6.5)	止ネジ	1	
5	0033938	Collar (ø 4x13x3mm)	エアバルブ補助カラー	1	
6	004406	Screw (11/64-40x8)	止ネジ	1	
7	0033937	Return Spring (Large)	補助バネ(大)	1	
8	2101548	Air Valve Support	エアバルブ取付	1	
9	2101549	Air Valve Support	エアバルブ取付	1	
10	110049	Screw (M3-0.7x10)	止ネジ	1	
11	0010017	Bamboo Joint (ø 5-5x4)	バンプ継手	1	
12	0008881	Gasket	パッキン	1	
13	0010018	Air Valve (4 part)	エアバルブ	1	
14	0016158	Connector (ø 5-5x2.5)	継手	1	
15	2101548	Air Valve Press Plate	エアバルブ押込板	1	
16	110010	Screw (M3-0.7x10)	止ネジ	1	
17	100001	Nut	ナット	1	
18	0010019	Air Valve (2 part)	エアバルブ	1	

(注) "CL"装置(組)の品名
 Note: Parts No. of "CL" Device
 for AL/R2.....2101542
 for AZ/R2.....2121005

(注) カラーの寸法は内径×外径×厚を表しています。
 Note: Size of Collar ... Inside dia. × Outside dia. × Thickness



"L" DEVICE(1)

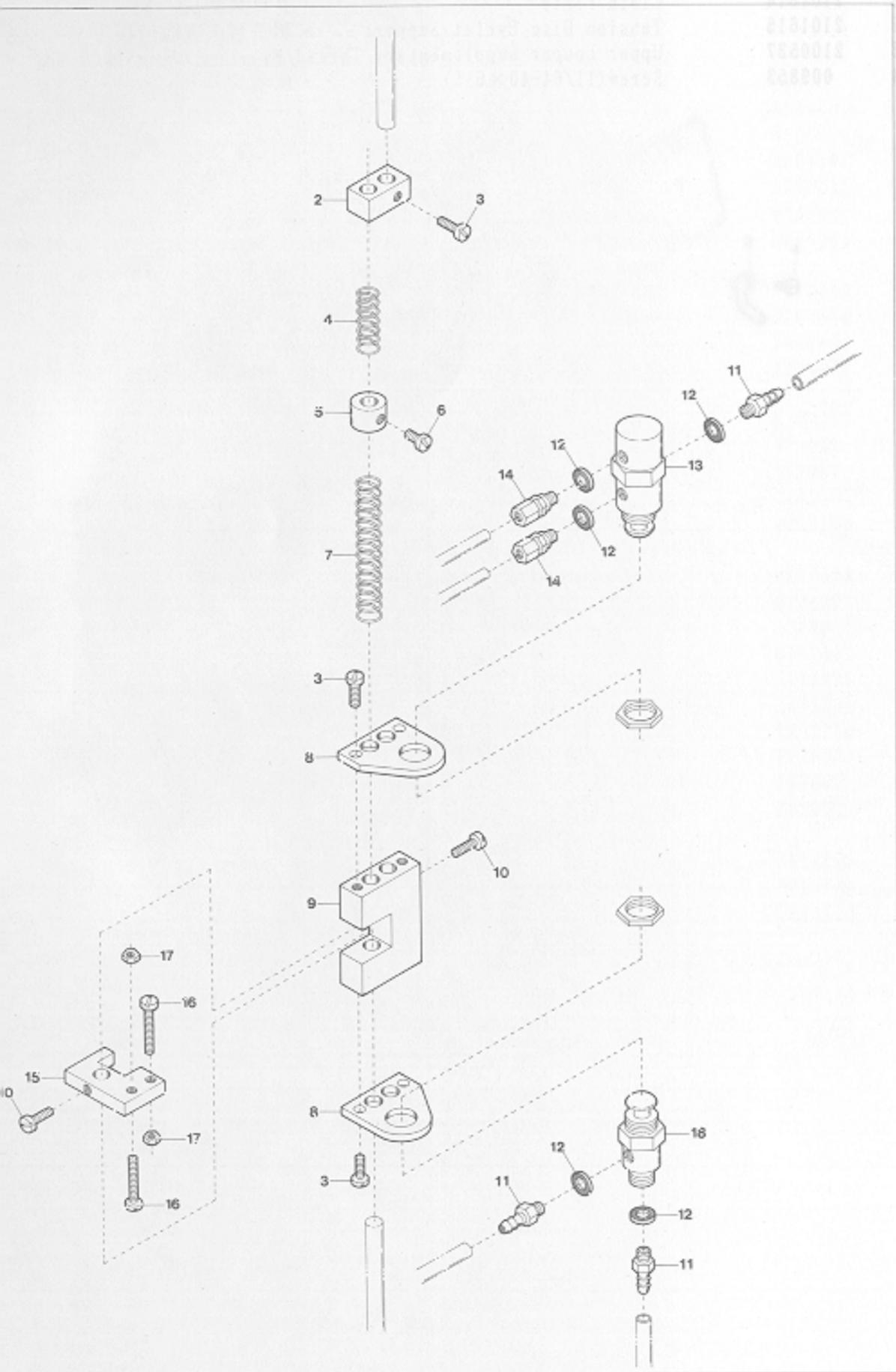

"CL" DEVICE(1)

Ref. No.	Parts No.	Description	品名	Amt. Req.
1	2101547	Air Valve, Complete Set	エアバルブ(組)	1
2	2101551	Return Spring Stop	補助バネストッパ	1
3	007627	Screw(M4-0.7×6)	止ネジ	6
4	0068181	Return Spring(Small)	補助バネ(小)	1
5	0033938	Collar(6.4×13×9mm)	エアバルブ補助カラー	1
6	004406	Screw(11/64-40×8)	止ネジ	1
7	0033937	Return Spring(Large)	補助バネ(大)	1
8	2101548	Air Valve Support	エアバルブ取付	2
9	2101549	Air Valve Basement	エアバルブ装置	1
10	110049	Screw(M4-0.7×10)	止ネジ	4
11	0010017	Bamboo Joint(M5-6×4)	bambu継手	3
12	000623	Gasket	パッキン	5
13	0010333	Air Valve(4 port)	エアバルブ	1
14	0010258	Connector(M5-4×2.5)	継手	2
15	2101550	Air Valve Press Plate	エアバルブ押し板	1
16	110010	Screw(M4-0.7×16)	止ネジ	2
17	100001	Nut	ナット	2
18	0010052	Air Valve(2 port)	エアバルブ	1

(注) "CL"装置(組)の品番

Note: Parts No. of "CL" Device, C. Set
 for AZ/K2.....2101552
 for AZF/K2.....2121005

(注) カラーの寸法は内径×外径×幅を表しています。

Note: Size of Collar ... Inside dia. × Outside dia. × Thickness

(注) ビニールパイプ製注文の際は品番と長さをお知らせください。

Note: As for Vinyl tube, your order must be accompanied with No. and length.

"CL" DEVICE(2)

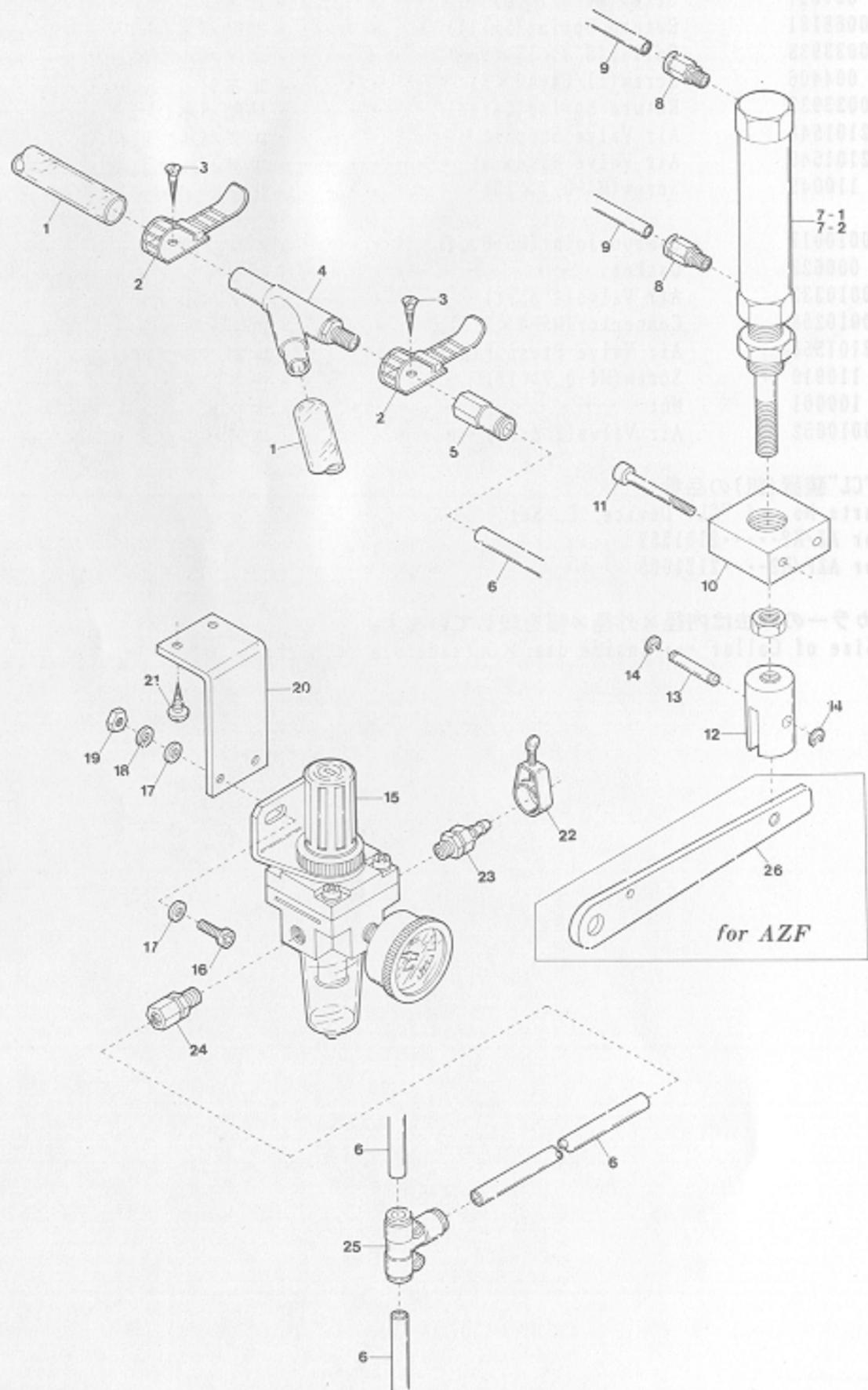

"CL"装置(2)

67

"CL" DEVICE(2)

Ref. No.	Parts No.	Description	品名	Amt. Req.
1	0022392	Nylon Hose	ナイロンホース	2
2	0011987	UL Clamp	ULクランプ	2
3	009142	Screw(9/64-40×7.1)	止ネジ	2
4	0010310	Venturi Tube	ベンチュリ管	1
5	0010290	Connector(φ6-PT1/8)	コネクタ	1
6	0010261	Vinyl Tube(6×4mm)	ビニールパイプ	-
7-1	1091082	Presser Foot Lifter Cylinder(for AZF)	押エ揚ゲシリンダ(AZF用)	1
7-2	1091013	" " (for AZ)	" " (AZ用)	1
8	0010055	Connector(φ4-PT1/8)	コネクタ	2
9	0010260	Vinyl Tube(4×2.5mm)	ビニールパイプ	-
10	1260000	Cylinder Holder	押エ揚ゲシリンダ取付台	1
11	006219	Screw(M4-0.7×30)	止ネジ	2
12	0012029	Presser Lifter Holder	押エ揚ゲホルダ	1
13	0012030	Presser Lifter Holder Pin	押エ揚ゲホルダピン	1
14	0033024	Retaining Ring	ストップリング	2
15	0010073	Regulator	レギュレータ	1
16	009960	Screw(M5-0.8×16)	止ネジ	2
17	000669	Washer	ワッシャ	4
18	000600	Spring Washer	スプリングワッシャ	2
19	000009	Nut	ナット	2
20	0013218	Regulator Support	レギュレータ取付板	1
21	006905	Screw(φ5.1×20)	止ネジ	2
22	0033939	Hose Band(1/4 inch)	ホースバンド	1
23	0010108	Hose Connector(φ3-1/4)	ホースユニオン	1
24	0010264	Connector(φ6-1/4)	コネクタ	1
25	1094008	T-Joint(φ6)	ユニオンT継手	1
26	2100193	Presser Foot Lifter Lever(for AZF)	押エ揚ゲレバー(AZF用)	1

(注) ビニールパイプ御注文の際は品番と長さをお知らせ下さい。
 Note: As for Vinyl Tube, your order must be accompanied with No. and length.

EXTRA PARTS

Feed Dog plated with Rubber ラバー送り

AZ6000H

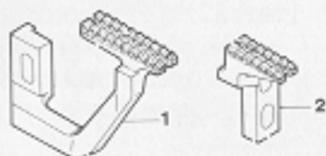

AZ6003H, 6020H

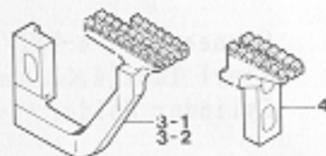

EXTRA PARTS

Ref. Parts

Ref. No.	Parts No.
1	2109070
2	2109074
3-1	2109072
3-2	2109078
4	2109076

Description

Description	品名	Amt. Req.
Differential Feed Dog	前送り	1
Main Feed Dog	後送り	1
Differential Feed Dog	前送り	1
" "	"	1
Main Feed Dog	後送り	1

特注部品

68

Amt. Req.

Parts No.	Applicable Model 適用機種
2109070 2109074	AZ6000H-03, 04
2109072	AZ6003H-04, 05 6020H-X4, X5, Y5 6025H-X4, X5, Y5
2109078	AZ6003H-06 6020H-Y6
2109076	AZ6003H-04, 05, 06 6020H-X4, X5, Y5, Y6 6025H-X4, X5, Y5, Y6



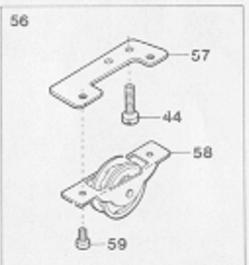
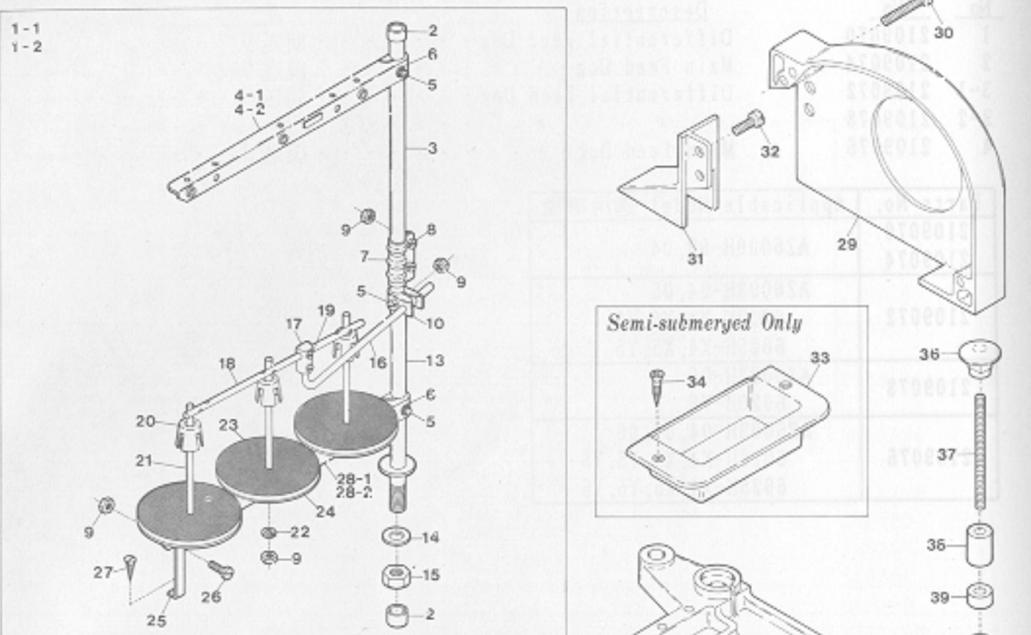

Full-submerged Setting

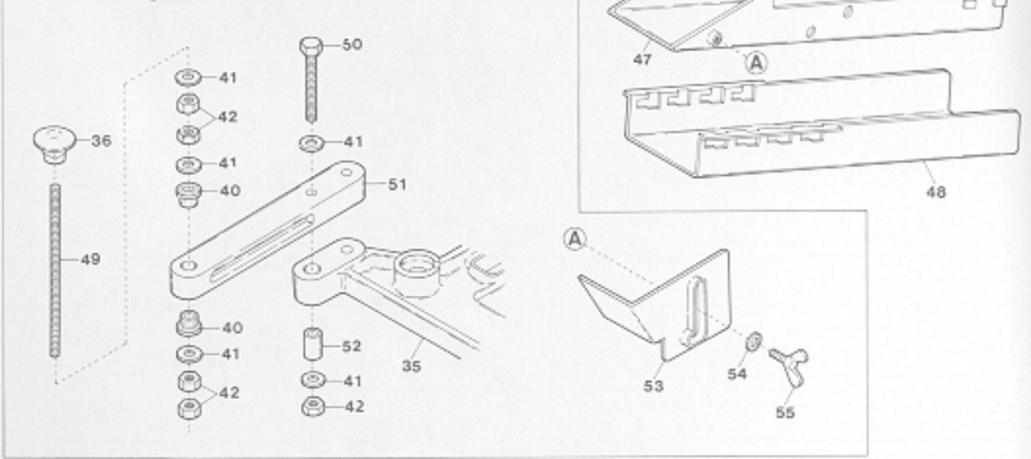

THREAD STAND & SUPPORTING BOARD

糸立台及び受ケ板

Ref. No.	Parts No.	Description	品名	Amt. Req.
1-1	0099072	Thread Stand, C. Set(3 Spools Type)	糸立台(組)(3本糸用)	1
1-2	0099073	" " (4 Spools Type)	" (4本糸用)	1
2	0099057	Column Cap	コラムキャップ	2
3	0099058	Column Pipe(Upper)	コラムパイプ(上)	1
4-1	0099060	Thread Hanger(3 Spools Type)	スレッドハンガ(3本糸用)	1
4-2	0099059	" (2 Spools Type)	" (2本糸用)	2
5	000147	Screw	止ネジ	3
6	000148	Washer	ワッシャ	2
7	0099061	Column Pipe Connector	コラムパイプ継手	1
8	000149	Screw	止ネジ	2
9	000152	Nut	ナット	7
10	0099062	Thread Guide Holder	糸案内ホルダ	1
11				
12				
13	0099063	Column Pipe(Lower)	コラム(下)	1
14	300027	Washer	ワッシャ	1
15	000153	Nut	ナット	1
16	0099030	Thread Guide Bar	糸案内支エ棒	1
17	0099031	Thread Guide Bar Bracket	支エ棒接点	1
18	0099064	Thread Guide	糸案内	1
19	003632	Screw	止ネジ	2
20	0099065	Spool Cushion	スプールクッション	3
21	0099066	Spool Pin	スプール軸	3
22	000600	Spring Washer	スプリングワッシャ	3
23	0099067	Spool Mat	スプールマット	3
24	0099068	Spool Seat Disc	受ケ皿	3
25	0099069	Spool Holder Stay	スプールホルダ支エ	1
26	000158	Screw	止ネジ	1
27	000159	Wood Screw	木ネジ	1
28-1	0099070	Spool Holder(3 Spools Type)	スプールホルダ(3本糸用)	1
28-2	0099071	" (2 Spools Type)	" (2本糸用)	2
29	2100381	Belt Cover	ベルトカバー	1
30	110015	Screw(M4-0.7x25)	止ネジ	2

※ Ref. No. 31 to 59 See the following page.

THREAD STAND & SUPPORTING BOARD

糸立台及び受ケ板

Ref. No.	Parts No.	Description	品名	Amt. Req.
31	2100382	Supplementary Belt Cover	ベルト補助カバー	1
32	110013	Screw(M4-0.7x8)	止ネジ	2
33	2100376	Chip Receiver(Semi-submerged only)	切屑受ケ(半沈式のみ)	1
34	009929	Wood Screw(φ3.5x24)	木ネジ	2
35	2100339	Supporting Board	受ケ板	1
36	000070	Hanging Nut	吊りナット	4
37	009861	Hanging Bolt(Semi-submerged only)	吊りボルト(半沈式のみ)	4
38	2101450	Spacer(15mm)	受ケ板スペーサ	4
39	2101451	Spacer(5mm)(See the below)	受ケ板スペーサ(下記参照)	4
40	0020064	Supporting Board Rubber Cushion	受ケ板ゴム座	8
41	000162	Washer(Semi-submerged)	ワッシャ(半沈式)	4
41	000162	" (Full-submerged)	ワッシャ(全沈式)	20
42	000016	Nut(Semi-submerged)	ナット(半沈式)	8
42	000016	Nut(Full-submerged)	ナット(全沈式)	20
43	2100375	Chute(Upper) Support	シュート(上)取付板	1
44	009992	Screw(M4-0.7x10)	止ネジ	6
45	000644	Spring Washer	スプリングワッシャ	2
46				
47	2100337	Chute(Upper)	シュート(上)	1
48	2100338	Chute(Lower)	シュート(下)	1
49	009864	Hanging Bolt(Full-submerged only)	吊りボルト(全沈式のみ)	4
50	009871	Bolt(Full-submerged only)	ボルト(全沈式のみ)	4
51	0020057	Supporting Board Connector(Full-submerged only)	受ケ板コネクタ(全沈式のみ)	2
52	0020045	Supporting Board Sleeve(Full-submerged only)	受ケ板スリーブ(全沈式のみ)	2
53	2100335	Supplementary Chute Cover	シュート補助カバー	1
54	000538	Washer	ワッシャ	1
55	140011	Wing Bolt	蝶ボルト	1
56	0020078	Idler, C. Set(for Left Footing Pedal)(Extra 7付(1個)(特品)	アイドラ取付板	1
57	0020077	Idler Support	アイドラ取付板	1
58	0020076	Idler	アイドラ	1
59	009995	Screw(M3-0.6x5)	止ネジ	2

※ Ref. No. 1 to 20 See the preceding page.

(注) テーブルの厚さ45mmの場合は不要
Note: Not necessary when the thickness of Table is 45mm.



KNIFE DRIVING MECHANISM

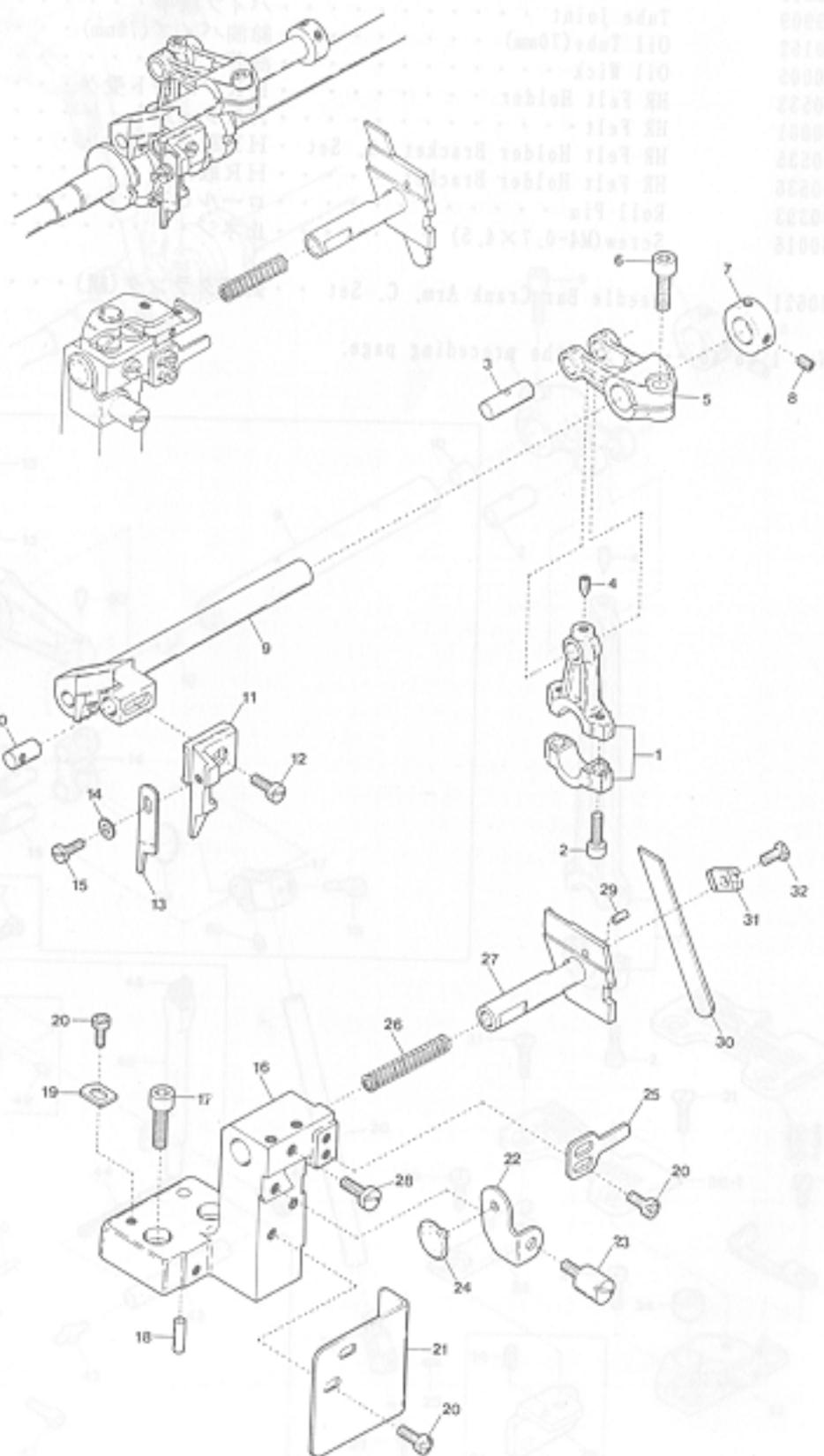

KNIFE DRIVING MECHANISM

メス機構

Ref. No.	Parts No.	Description	品名	Amt. Req.
1	2100160	Upper Knife Driving Connecting Rod	上メスロッド	1
2	120001	Screw(M4-0.7×14)	止ネジ	2
3	2100173	Driving Lever Pin	上メス軸腕ピン	1
4	160002	Screw(M4-0.7×5)	止ネジ	1
5	2100162	Upper Knife Driving Lever	上メス軸腕	1
6	120006	Screw(M6-1×12)	止ネジ	1
7	2100161	Collar(10×19×9mm)	上メス軸カラー	1
8	160003	Screw(M5-0.8×5)	止ネジ	2
9	2120024	Upper Knife Driving Shaft	上メス軸	1
10	2100165	Upper Knife Holder Positioner	上メスホルダピン	1
11	2100164	Upper Knife Holder(Flat Type)	上メスホルダ(平)	1
12	110035	Screw(M4-0.7×10)	止ネジ	1
13	0020496	Upper Knife(Flat Type)	上メス(平)	1
14	000532	Washer	ワッシャ	1
15	110004	Screw(M3.5-0.6×8)	止ネジ	1
16	2100171	Lower Knife Holder Basement	下メス取付台	1
17	120011	Screw(M6-1×18)	止ネジ	2
18	000779	Knock Pin	ノックピン	1
19	2100172	Holder Basement Positioner	下メス取付台ストッパ	1
20	110012	Screw(M4-0.7×5)	止ネジ	5
21	2100021	Front Cover	前カバー	1
22	2100170	Lower Knife Holder Spring Stop	下メスバネ受け	1
23	2100009	Cloth Plate Spring Pin	バネ受けピン	1
24	2100174	Cloth Plate Rubber Cushion	緩衝ゴム	1
25	2100169	Lower Knife Holder Locking Plate	下メス台回り止め	1
26	0032919	Lower Knife Holder Spring	下メスバネ	1
27	2100166	Lower Knife Holder	下メス台	1
28	110046	Screw(M5-0.8×12)	止ネジ	1
29	000688	Guide Pin	ガイドピン	1
30	2100167	Lower Knife	下メス	1
31	2100168	Lower Knife Clamp	下メス押エ	1
32	140014	Scwer(M4-0.7×8)	止ネジ	1

(注) カラーの寸法は内径×外径×幅を表しています。
 Note: Size of Collar ... Inside dia.×Outside dia.×Thickness

AZ6000H Class LIST of MAIN SPARE PARTS(主要部品リスト)(1)

Models	Main Parts	Needle Clamp	Presser Foot, C. Set	Presser Foot Hinge	Presser Foot (Lower)	Stitch Tongue
		針止メ	押エ(組)	押エヒンジ	押エ(下)	押エの爪
AZ6003H-03		2109132	2107300	0024100	2107280	2107220
03/K2 (KR2)		"	2107335	"	"	"
03/MU5		"	2107320	"	"	"
03/MS/B3		"	2107317	"	2107280	2107224
03/MS/B3/K2		"	2107372	"	"	"
03/BT13		"	2107317	"	"	"
03-3		"	2107350	0024420	2107036	2107006
04		"	2107301	0024100	2107280	2107221
04/K2 (KR2)		"	2107336	"	"	"
04/MU5		"	2107321	"	"	"
04/MS/B3		"	2107318	"	"	2107225
04/MS/B3/K2		"	2107373	"	"	"
04/BT13		"	2107318	"	"	"
04-3		"	2107351	0024420	0024422	2107008
04-54		"	2107346	0024100	2107286	2107243
04-54/K2		"	2107358	"	"	"
05		"	2107302	"	2107280	2107222
05/K2 (KR2)		"	2107337	"	"	"
05/MU5		"	2107322	"	"	"
05-3		"	2107352	0024420	2107037	2107009
05-61		"	2107393	0024100	2107291	2107254
05-3/MT2		"	2107381	0024420	2107037	2107009
06		"	2107303	0024100	2107280	2107223
06/K2		"	2107338	"	"	"
06/MU5		"	2107323	"	"	"
06-3		"	2107353	0024420	0024425	2107020
6000H-03		"	2107031	0024100	2107030	2107000
04		"	2107032	"	"	2107004
04-M		"	"	"	"	"
04-54		"	"	"	"	"

Presser Foot Chain Shield	Stitch Plate	Differential	Main	Auxiliary	Upper	Lower
		Feed Dog	Feed Dog	Feed Dog	Looper	Looper
空糸押エ	針板	前送り	後送り	小送り	上ルーパ	下ルーパ
0034535	2108002	2109007	2109006	2109067	2109320	2109300
2107219	"	"	"	"	"	"
0022416	"	"	"	"	"	"
0034535	2108011	2109010	2109011	"	"	"
2107219	"	"	"	"	"	"
0034535	"	"	"	"	"	"
	2108002	2109007	2109006	"	"	"
0034535	2108003	2109005	"	"	"	"
2107219	"	"	"	"	"	"
0022416	"	"	"	"	"	"
0034535	2108008	2109010	2109011	"	"	"
2107219	"	"	"	"	"	"
0034535	"	"	"	"	"	"
	2108003	2109005	2109006	"	"	"
0034535	2108010	"	"	2109052	2109324	2109331
2107219	"	"	"	"	"	"
0034535	2108007	"	"	2109067	2109320	2109300
2107219	"	"	"	"	"	"
0022416	"	"	"	"	"	"
	"	"	"	"	"	"
0034535	2108112	2109007	"	"	"	"
0022156	2108007	2109005	"	"	"	"
0034535	2108012	2109009	"	"	"	"
2107219	"	"	"	"	"	"
0022416	"	"	"	"	"	"
	"	"	"	"	"	"
	2108001	2109000	2109001	"	"	"
	2108000	"	"	"	"	"
	2108032	"	"	"	"	"
	2108100	"	"	2109052	"	"

1
AZ6000H Class LIST of MAIN SPARE PARTS(主要部品リスト)(2)

Models	Main Parts	Needle Clamp	Presser Foot, C. Set	Presser Foot Hinge	Presser Foot (Lower)	Stitch Tongue
		針止メ	押エ(組)	押エヒンジ	押エ(下)	押エの爪
AZ6015H-04-57/B3/K2		2109132	2107370	0024100	2107290	2107226
6016H-02		"	2107084	2107085	0024505	0024506
6017H-04-57/B3/K2		"	2107063	0024100	2107045	2107046
AZ6020H-Y4		2109130	2117012	0024100	2117000	2117011
Y5		"	2107310	"	2107280	2107230
Y5/K2(KR2)		"	2107339	"	"	"
Y5/MU5		"	2107324	"	"	"
Y5-3		"	2107356	0024420	2107037	2107011
Y6		"	2107311	0024100	2107280	2107231
Y6/K2(KR2)		"	2107340	"	"	"
Y6/MU5		"	2107325	"	"	"
Y6-3		"	2107357	0024420	0024425	2107019
Y6-54		"	2107044	0024100	2107039	2107042
Y6-54/K2		"	2107359	"	"	"
X4		2109131	2107312	"	2107280	2107232
X4/K2(KR2)		"	2107341	"	"	"
X4/MU5		"	2107326	"	"	"
X4/BT13		"	2107319	"	"	2107247
X4-3		"	2107354	0024420	0024422	2107017
X5		"	2107313	0024100	2107280	2107233
X5/K2(KR2)		"	2107342	"	"	"
X5/BT13		"	2107398	"	"	2107257
X5-3		"	2107355	0024420	2107037	2107023

Presser Foot Chain Shield	Stitch Plate	Differential	Main	Auxiliary	Upper	Lower
		Feed Dog	Feed Dog	Feed Dog	Looper	Looper
空系押エ	針板	前送り	後送り	小送り	上ルーバ	下ルーバ
2107219	2108009	2109010	2109011	2109052	2109320	2109300
0022156	2108016	2109017	2109018	2109019	"	"
0034535	2108009	2109010	2109011	2109052	"	"
0034535	2108120	2109005	2109006	2109067	2109322	"
"	2108004	"	"	"	"	"
2107219	"	"	"	"	"	"
0022416	"	"	"	"	"	"
0034535	2108005	2109009	"	"	"	"
2107219	"	"	"	"	"	"
0022416	"	"	"	"	"	"
0034535	2108021	"	"	2109052	2109326	2109331
2107219	"	"	"	"	"	"
0034535	2108006	2109005	"	2109067	2109322	2109300
2107219	"	"	"	"	"	"
0022416	"	"	"	"	"	"
0034535	2108013	2109015	2109016	"	"	"
0034535	2108006	2109005	2109006	"	"	"
0034535	2108014	"	"	"	"	"
2107219	"	"	"	"	"	"
0034535	2108119	2109015	2109016	"	"	"
0034535	2108014	2109005	2109006	"	"	"

5000H Class LIST of MAIN SPARE PARTS(主要部品リスト)(3)

Main Parts	Needle Clamp	Presser Foot, C. Set	Presser Foot Hinge	Presser Foot (Lower)	Stitch Tongue
	針止メ	押エ(組)	押エヒンジ	押エ(下)	押エの爪
21H-A6	2109135	2107314	0024100	2107282	2107234
25H-Y5	2109130	2107308	"	2107290	2107240
Y5/K2	"	2107363	"	"	"
Y5/MU5	"	2107330	"	"	"
Y6	"	2107309	"	"	2107241
Y6/K2	"	2107364	"	"	"
Y6/MU5	"	2107331	"	"	"
X4	2109131	2107306	"	"	2107238
X4/K2	"	2107361	"	"	"
X4/MU5	"	2107328	"	"	"
032H-Y5	2109134	2107347	0024100	2107289	2107244
Y6	"	2107348	"	"	2107245
Y7	"	2107349	"	"	2107246
035H-Y5	2109134	2107332	"	2107284	2107240
Y6	"	2107333	"	"	2107241
Y7	"	2107334	"	"	2107242
Y7-54	"	"	"	"	"
045H-04	2109132	0024354	"	0022153	0021876
046H-Y5	2109130	2107069	"	"	2107068
Y6	"	2107390	"	"	0021879
X4	2109131	2107389	"	"	2107250
051H-04	2109132	2107385	"	2107279	0036822
04/MT2	"	2107305	"	"	"
05	"	2107386	"	"	0034257
098H-Y5	2109130	2107397	"	2107278	2107229

Presser Foot Chain Shield	Stitch Plate	Differential Feed Dog	Main Feed Dog	Auxiliary Feed Dog	Upper Looper	Lower Looper
空糸押エ	針板	前送り	後送り	小送り	上ルーバ	下ルーバ
0034535	2108030	2109009	2109006	2109052	2109341	2109300
"	2108004	2109005	"	2109067	2109322	"
2107219	"	"	"	"	"	"
0022416	"	"	"	"	"	"
0034535	2108005	2109009	"	"	"	"
2107219	"	"	"	"	"	"
0022416	"	"	"	"	"	"
0034535	2108006	2109005	"	"	"	"
2107219	"	"	"	"	"	"
0022416	"	"	"	"	"	"
0034535	2108062	2109084	2109086	2109052	2109342	2109331
"	2108063	"	"	"	"	"
"	2108064	2109085	"	"	"	"
"	2108062	2109084	"	"	"	"
"	2108063	"	"	"	"	"
"	2108064	2109085	"	"	"	"
"	2128010	2109009	2109006	"	"	"
"	2108003	2109020	2109021	2109067	2109320	2109300
"	2108004	"	"	"	2109322	"
"	2108005	2109022	2109023	"	"	"
"	2108006	2109020	2109021	"	"	"
2107203	2108010	2109005	2109006	2109052	2109320	"
0022416	"	"	"	"	"	"
2107203	2108026	"	"	"	"	"
0034535	2108118	2109068	"	2109067	2109322	"

Parts No.	Page No.	Ref. No.	Weight (g)	Parts No.	Page No.	Ref. No.	Weight (g)	Parts No.	Page No.	Ref. No.	Weight (g)
000002	47	10		000177	26	7		000340	4	9	
000002	49	10		000177	27	7		000361	16	48	
000002	59	39		000177	29	7		000361	54	15	
000009	45	8		000177	33	7		000361	56	9	
000009	64	5		000177	37	7		000393	6	49	
000009	67	19		000177	43	35		000419	63	13	
000010	17	19		000177	44	35		000456	13	6	
000010	59	50		000177	52	35		000474	5	3	
000010	61	19		000177	53	35		000487	8	18	
000011	63	18		000177	57	35		000488	47	11	
000012	59	40		000177	58	35		000488	49	11	
000014	43	14		000177	61	10		000496	43	26	
000014	44	14		000178	4	5		000496	44	26	
000014	52	14		000178	17	8		000496	52	26	
000014	53	14		000178	23	5		000496	53	26	
000014	57	14		000178	24	5		000496	57	26	
000014	58	14		000178	25	5		000496	58	26	
000014	59	38		000178	26	5		000520	3	31	
000014	64	17		000178	27	5		000520	11	38	
000015	43	24		000178	29	5		000526	5	41	
000015	44	24		000178	33	5		000530	31	36	
000015	52	24		000178	37	5		000532	7	14	
000015	53	24		000178	43	34		000533	15	27	
000015	57	24		000178	44	34		000533	16	15	
000015	58	24		000178	52	34		000533	18	18	
000016	69	42		000178	53	34		000533	59	9	
000021	43	17		000178	57	34		000535	16	49	
000021	44	17		000178	58	34		000535	54	16	
000021	52	17		000178	61	8		000535	56	10	
000021	53	17		000187	46	8		000538	2	6	
000021	57	17		000187	48	8		000538	13	9	
000021	58	17		000234	31	34		000538	31	24	
000023	47	28		000286	43	6		000538	35	26	
000023	62	25		000286	44	6		000538	47	26	
000023	64	30		000286	52	6		000538	62	23	
000035	6	26		000286	53	6		000538	64	28	
000056	17	13		000286	57	6		000538	69	54	
000056	61	13		000286	58	6		000550	59	48	
000070	69	36		000306	31	30		000561	11	39	
000147	69	5		000306	59	15		000567	14	5	
000148	69	6		000330	43	21		000600	45	7	
000149	69	8		000330	44	21		000600	67	18	
000152	69	9		000330	52	21		000690	69	22	
000153	69	15		000330	53	21		000613	31	29	
000158	69	26		000330	57	21		000613	35	3	
000159	69	27		000330	58	21		000613	59	14	
000162	69	41		000334	15	35		000621	31	28	
000172	15	34		000334	16	23		000621	59	12	
000172	16	22		000334	17	12		000622	17	3	
000172	18	25		000334	18	26		000622	61	3	
000177	4	7		000334	45	19		000623	64	19	
000177	17	10		000334	59	52		000623	66	12	
000177	23	7		000334	61	12		000644	1	31	
000177	24	7		000335	59	31		000644	47	27	
000177	25	7		000335	60	7		000644	62	24	

Parts No.	Page No.	Ref. No.	Weight (g)	Parts No.	Page No.	Ref. No.	Weight (g)	Parts No.	Page No.	Ref. No.	Weight (g)
000644	64	29		001892	40	29		004150	18	24	
000644	69	45		001892	49	16		004182	20	15	
000665	34	3		001904	17	15		004204	22	14	
000665	35	30		001904	61	15		004205	16	45	
000665	63	27						004205	54	12	
000669	11	6		003632	69	19		004205	56	6	
000669	45	6		003635	35	6		004236	36	12	
000669	63	31		003636	5	26		004236	38	14	
000669	64	4		003637	1	9		004236	40	14	
000669	67	17		003637	2	13		004236	60	4	
000688	7	29		003637	6	23		004237	3	43	
000690	11	34		003637	16	44		004237	19	19	
000693	6	40		003637	23	21		004237	20	9	
000755	38	5		003637	24	19		004237	21	22	
000755	40	5		003637	25	11		004237	22	8	
000779	7	18		003637	26	30		004237	23	16	
000779	9	33		003637	27	17		004237	24	34	
000932	22	20		003637	29	17		004237	25	18	
000933	22	21		003637	31	21		004237	26	28	
				003637	33	21		004237	28	6	
001049	59	27		003637	37	21		004237	30	6	
001095	4	26		003637	46	29		004237	32	6	
001123	1	4		003637	48	29		004237	33	19	
001156	35	27		003637	54	11		004237	36	6	
001175	59	10		003637	56	5		004237	37	16	
001196	15	43		003637	60	11		004237	38	7	
001196	16	31		003638	35	8		004237	39	9	
001196	18	34		003638	59	29		004237	40	7	
001196	35	18						004237	51	9	
001196	63	40		004096	8	37		004237	54	30	
001202	60	10		004097	8	35		004237	56	23	
001225	15	42		004100	17	20		004237	60	24	
001225	16	30		004100	46	20		004265	4	6	
001225	18	33		004100	48	20		004265	23	8	
001228	4	22		004100	61	20		004265	24	8	
001228	21	20		004103	63	12		004265	25	8	
001228	22	16		004106	15	45		004265	26	8	
001228	26	26		004106	16	33		004265	27	8	
001228	28	22		004106	18	36		004265	29	8	
001228	30	12		004125	31	46		004265	33	8	
001228	39	18		004127	35	31		004265	37	8	
001228	51	16		004131	15	16		004327	42	9	
001230	46	35		004131	16	7		004351	8	40	
001230	48	35		004131	18	7		004351	15	12	
001326	59	32		004131	22	6		004351	16	3	
001330	2	20		004131	32	9		004351	18	3	
001330	15	37		004131	33	17		004351	19	3	
001330	16	25		004131	38	10		004351	20	3	
001330	18	28		004131	40	10		004351	21	13	
001331	3	28		004138	22	10		004351	22	3	
001333	59	16		004139	38	11		004351	23	13	
001396	4	11		004139	40	11		004351	24	12	
001457	35	24		004144	29	43		004351	25	15	
001613	60	27		004150	15	33		004351	26	19	
001892	38	29		004150	16	21		004351	28	3	

INDEX

Page = 3

Parts No.	Page No.	Ref. No.	Weight (g)	Parts No.	Page No.	Ref. No.	Weight (g)	Parts No.	Page No.	Ref. No.	Weight (g)
004351	30	3		005128	53	16		007627	31	37	
004351	32	3		005128	57	16		007627	66	3	
004351	33	13		005128	58	16		007903	17	11	
004351	36	3		005345	6	31		007903	43	36	
004351	37	13		005505	45	20		007903	44	36	
004351	39	3		005512	62	8		007903	52	36	
004351	42	3		005550	59	20		007903	53	36	
004351	51	3		005585	59	26		007903	57	36	
004351	54	24		005587	62	7		007903	58	36	
004351	56	17		005588	59	44		007903	61	11	
004353	59	6		005588	60	14		007904	43	8	
004353	62	4		005589	31	27		007904	44	8	
004358	41	5		005589	59	11		007904	52	8	
004358	49	20		005591	60	30		007904	53	8	
004358	55	5		005625	46	2		007904	57	8	
004358	59	25		005625	48	2		007904	58	8	
004404	38	8		005650	63	10					
004404	40	8						009142	67	3	
004406	59	35		006092	43	20		009150	59	2	
004406	66	6		006092	44	20		009604	35	17	
004440	60	33		006092	52	20		009624	15	31	
				006092	53	20		009624	16	19	
				006092	57	20		009624	18	22	
				006092	58	20		009624	63	35	
				006188	63	17		009730	19	6	
				006219	67	11		009730	24	15	
				006444	15	48		009736	34	19	
				006444	16	36		009746	43	23	
				006444	18	39		009746	44	23	
				006444	63	38		009746	52	23	
				006816	1	22		009746	53	23	
				006820	60	8		009746	57	23	
				006905	45	10		009746	58	23	
				006905	64	7		009753	5	4	
				006905	67	21		009779	63	42	
				006910	41	29		009814	45	27	
				006910	47	22		009853	43	29	
				006910	50	17		009853	52	29	
				006910	55	29		009853	57	29	
				006910	62	15		009853	65	4	
				006910	64	22		009861	69	37	
								009864	69	49	
				007006	15	28		009871	69	50	
				007006	16	16		009909	6	42	
				007006	18	19		009909	14	13	
				007606	59	37		009929	69	34	
				007609	60	19		009931	59	47	
				007619	15	46		009960	45	5	
				007619	16	34		009960	64	3	
				007619	18	37		009960	67	16	
				007619	63	36		009992	69	44	
				007623	38	21		009993	47	8	
				007623	40	21		009993	49	8	
				007623	46	37		009993	64	18	
				007623	48	37		009994	43	12	

INDEX

Page = 4

Parts No.	Page No.	Ref. No.	Weight (g)	Parts No.	Page No.	Ref. No.	Weight (g)	Parts No.	Page No.	Ref. No.	Weight (g)
009994	44	12		0011335	47	23-1		0020005	1	15	
009994	52	12		0011336	47	23-2		0020016	2	23	
009994	53	12		0011338	47	25-1		0020045	69	52	
009994	57	12		0011339	47	25-2		0020052	3	15	
009994	58	12		0011709	41	28		0020057	69	51	
009995	43	15		0011709	47	21		0020064	69	40	
009995	44	15		0011709	50	16		0020076	69	58	
009995	47	5		0011709	55	28		0020077	69	57	
009995	49	5		0011709	62	14		0020078	69	56	
009995	52	15		0011709	64	21		0020101	4	13	
009995	53	15		0011839	43	11		0020101	43	27	
009995	57	15		0011839	44	11		0020101	44	27	
009995	58	15		0011839	57	11		0020101	52	27	
009995	69	59		0011839	58	11		0020101	53	27	
				0011840	41	6		0020101	57	27	
0010017	66	11		0011840	47	14		0020101	58	27	
0010018	64	12		0011840	55	6		0020103	43	4	
0010052	66	18		0011841	41	7		0020103	44	4	
0010054	64	16		0011841	47	15		0020103	52	4	
0010055	67	8		0011841	55	7		0020103	53	4	
0010073	64	2		0011882	64	27		0020103	57	4	
0010073	67	15		0011883	64	26		0020103	58	4	
0010108	64	1		0011930	50	18		0020118	4	4	
0010108	67	23		0011942	52	11		0020118	17	7	
0010143	64	11		0011942	53	11		0020118	23	4	
0010258	64	20		0011943	50	15-1		0020118	24	4	
0010258	66	14		0011943	62	13-1		0020118	25	4	
0010260	63	46		0011944	50	15-2		0020118	26	4	
0010260	64	32		0011944	62	13-2		0020118	27	4	
0010260	67	9		0011945	50	15-3		0020118	29	4	
0010261	67	6		0011945	62	13-3		0020118	33	4	
0010263	45	11		0011946	50	15-4		0020118	37	4	
0010264	67	24		0011946	62	13-4		0020118	43	33	
0010287	63	4		0011954	47	20		0020118	44	33	
0010290	45	22		0011967	47	6		0020118	52	33	
0010290	67	5		0011970	41	26		0020118	53	33	
0010291	50	8		0011973	50	20		0020118	57	33	
0010310	41	34		0011974	41	27		0020118	58	33	
0010310	45	23		0011974	50	21		0020118	61	7	
0010310	49	27		0011974	55	27		0020131	4	25	
0010310	67	4		0011974	62	18		0020137	1	29	
0010327	63	3		0011987	45	26		0020271	8	34	
0010333	66	13		0011987	67	2		0020350	11	45	
				0011995	41	22		0020401	12	11	
0011180	62	16		0011995	50	11		0020472	3	19	
0011182	62	17		0011995	55	22		0020491	15	2	
0011183	62	19						0020496	7	13	
0011189	62	22		0012029	67	12		0020538	9	29	
0011190	59	19		0012030	67	13		0020538	11	36	
0011191	59	36						0020538	27	41	
0011192	62	20		0013085	63	5		0020538	29	41	
0011322	55	24		0013218	64	6		0020538	36	37	
0011323	41	24		0013218	67	20		0020538	59	51	
0011324	41	25						0020616	31	20	
0011324	55	25		0020004	1	14		0020700	20	17	

INDEX

Page = 5

Parts No.	Page No.	Ref. No.	Weight (g)	Parts No.	Page No.	Ref. No.	Weight (g)	Parts No.	Page No.	Ref. No.	Weight (g)
0020989	47	7		0022446	15	36		0023707	60	17	
0020989	49	7		0022446	16	24		0023708	60	20	
				0022446	18	27		0023709	60	23	
0021005	19	17		0022447	15	38		0023710	60	25	
0021005	21	26		0022447	16	26		0023711	59	24	
0021005	24	32		0022447	18	29		0023712	59	43	
0021005	32	8		0022448	15	39		0023713	59	45	
0021005	36	8		0022448	16	27		0023714	59	1	
0021005	39	22		0022448	18	30		0023715	59	7	
0021015	8	36		0022837	16	56		0023717	59	30	
0021301	36	16		0022837	54	21		0023718	59	41	
0021450	38	30		0022837	56	14		0023720	62	5	
0021450	40	30						0023722	59	34	
0021450	49	17		0023169	16	43		0023723	59	28	
0021451	38	26		0023169	54	10		0023724	60	16	
0021451	40	26		0023169	56	4		0023725	59	13	
0021451	49	13		0023182	16	47-1		0023726	59	3	
0021456	38	28		0023182	54	14-1		0023728	17	18	
0021456	40	28		0023182	56	8-1		0023728	61	18	
0021456	49	15		0023184	16	42		0023734	62	3	
0021457	38	27		0023184	54	9		0023737	60	21	
0021457	40	27		0023184	56	3		0023739	60	2	
0021457	49	14		0023185	43	10		0023740	60	1	
0021705	29	42		0023185	44	10		0023741	60	3	
0021876	32	7		0023185	52	10		0023744	60	6	
0021879	33	15-2		0023185	53	10		0023747	60	15	
				0023185	57	10		0023750	59	4	
0022153	32	4		0023185	58	10		0023756	60	26	
0022153	33	14		0023187	43	19		0023763	59	5	
0022156	22	7		0023187	44	19		0023766	17	16	
0022215	4	36		0023187	52	19		0023766	61	16	
0022392	41	35		0023187	53	19		0023767	60	34	
0022392	49	26		0023187	57	19		0023768	60	35	
0022392	67	1		0023187	58	19		0023769	59	8	
0022404	41	33		0023189	43	13		0023799	59	49	
0022404	49	25		0023189	44	13					
0022416	36	5-2		0023189	52	13		0024083	4	2	
0022416	51	8		0023189	53	13		0024083	17	5	
0022435	15	40		0023189	57	13		0024083	23	2	
0022435	16	28		0023189	58	13		0024083	24	2	
0022435	18	31		0023220	46	31		0024083	25	2	
0022436	15	41		0023220	48	31		0024083	26	2	
0022436	16	29		0023368	46	23		0024083	27	2	
0022436	18	32		0023368	48	28		0024083	29	2	
0022443	15	47		0023369	46	27		0024083	33	2	
0022443	16	35		0023369	48	27		0024083	37	2	
0022443	18	38		0023370	46	32		0024083	43	31	
0022443	63	37		0023370	48	32		0024093	44	31	
0022444	15	49		0023399	46	34		0024083	52	31	
0022444	16	37		0023399	48	34		0024083	53	31	
0022444	18	40		0023473	12	19		0024083	57	31	
0022444	63	39		0023580	22	22		0024083	58	31	
0022445	15	32		0023700	59	46		0024083	61	5	
0022445	16	20		0023703	60	32		0024084	4	1	
0022445	18	23		0023705	60	18		0024084	17	4	

INDEX

Page = 6

Parts No.	Page No.	Ref. No.	Weight (g)	Parts No.	Page No.	Ref. No.	Weight (g)	Parts No.	Page No.	Ref. No.	Weight (g)
0024084	23	1		0024156	58	32		0031111	61	9	
0024084	24	1		0024156	61	17		0031831	14	3	
0024084	25	1		0024157	4	12					
0024084	26	1		0024157	17	6		0032425	4	24	
0024084	27	1		0024157	43	28		0032604	6	34	
0024084	29	1		0024157	44	28		0032684	5	25	
0024084	33	1		0024157	52	28		0032879	1	23	
0024084	37	1		0024157	53	28		0032919	7	26	
0024084	43	30		0024157	57	28		0032952	4	37	
0024084	44	30		0024157	58	28		0032952	17	21	
0024084	52	30		0024157	61	6		0032952	43	37	
0024084	53	30		0024308	16	46		0032952	44	37	
0024084	57	30		0024308	54	13		0032952	52	37	
0024084	58	30		0024308	56	7		0032952	53	37	
0024084	61	4		0024354	32	1		0032952	57	37	
0024085	2	21		0024420	19	2		0032952	58	37	
0024095	2	25		0024420	24	11		0032952	61	21	
0024100	8	39		0024421	19	7		0032971	23	3	
0024100	15	11		0024421	22	5		0032971	24	3	
0024100	16	2		0024421	24	16		0032971	25	3	
0024100	18	2		0024422	19	4-2		0032971	26	3	
0024100	19	14		0024422	24	24		0032971	27	3	
0024100	20	2		0024425	19	4-4		0032971	29	3	
0024100	21	12		0024425	24	13-2		0032971	33	3	
0024100	23	12		0024446	2	19		0032971	37	3	
0024100	24	29		0024503	22	15		0032971	43	18	
0024100	25	14		0024505	22	4		0032971	44	18	
0024100	26	18		0024506	22	9		0032971	52	18	
0024100	28	2						0032971	53	18	
0024100	30	2		0026184	46	33		0032971	57	18	
0024100	32	2		0026184	48	33		0032971	58	18	
0024100	33	12		0026312	46	12					
0024100	36	2		0026312	48	12		0033024	3	20	
0024100	37	12		0026466	17	2		0033024	46	9	
0024100	39	2		0026466	61	2		0033024	48	9	
0024100	42	2		0026467	17	1		0033024	67	14	
0024100	51	2		0026467	61	1		0033627	1	24	
0024100	54	23		0026470	59	17		0033711	16	47-2	
0024100	56	16						0033711	54	14-2	
0024129	21	3		0031111	4	6		0033711	56	8-2	
0024129	26	12		0031111	17	9		0033738	21	6	
0024129	28	12		0031111	23	6		0033738	26	15	
0024129	30	15		0031111	24	6		0033738	28	15	
0024129	36	17		0031111	25	6		0033738	30	18	
0024130	21	1		0031111	26	6		0033738	36	20	
0024130	26	10		0031111	27	6		0033806	43	2	
0024130	28	10		0031111	29	6		0033806	44	2	
0024130	30	13		0031111	33	6		0033806	52	2	
0024156	4	3		0031111	37	6		0033806	53	2	
0024156	17	17		0031111	43	7		0033806	57	2	
0024156	43	32		0031111	44	7		0033806	58	2	
0024156	44	32		0031111	52	7		0033807	43	5	
0024156	52	32		0031111	53	7		0033807	44	5	
0024156	53	32		0031111	57	7		0033807	52	5	
0024156	57	32		0031111	58	7		0033807	53	5	

INDEX

Page = 7

Parts No.	Page No.	Ref. No.	Weight (g)	Parts No.	Page No.	Ref. No.	Weight (g)	Parts No.	Page No.	Ref. No.	Weight (g)
0033807	57	5		0036092	63	24		0094547	35	23	
0033807	58	5		0036111	59	21		0094548	35	14	
0033890	43	3		0036132	59	22		0094549	35	16	
0033890	44	3		0036133	41	10		0094553	35	20	
0033890	52	3		0036133	47	18		0094556	35	19	
0033890	53	3		0036133	55	10		0094557	35	21	
0033890	57	3		0036133	59	33		0094562	31	39	
0033890	58	3		0036133	64	33					
0033932	41	32		0036161	60	9		0095068	35	10	
0033932	49	24		0036518	3	23		0095069	35	13	
0033934	45	21		0036816	35	5		0095072	35	12	
0033935	45	18		0036820	35	1					
0033936	45	17		0036822	36	7-1		0099030	69	16	
0033937	45	16		0036827	35	11		0099031	69	17	
0033937	66	7		0036853	43	9		0099057	69	2	
0033938	45	14		0036853	44	9		0099058	69	3	
0033938	66	5		0036853	52	9		0099059	69	4-2	
0033939	41	31		0036853	53	9		0099060	69	4-1	
0033939	45	2		0036853	57	9		0099061	69	7	
0033939	49	23		0036853	58	9		0099062	69	10	
0033939	67	22		0036905	16	54		0099063	69	13	
0033940	45	24		0036905	54	19		0099064	69	18	
0033953	45	13		0036905	56	12		0099065	69	20	
0033968	6	39						0099066	69	21	
				0037114	17	14		0099067	69	23	
0034257	36	7-2		0037114	61	14		0099068	69	24	
0034535	8	42		0037372	6	20		0099069	69	25	
0034535	19	18		0037668	14	16		0099070	69	28-1	
0034535	20	8		0037669	14	2		0099071	69	28-2	
0034535	21	28						0099072	69	1-1	
0034535	23	15		0038805	36	10		0099073	69	1-2	
0034535	24	33		0038806	36	11					
0034535	25	17						100000	11	40	
0034535	26	27		0060248	50	1		100001	1	12	
0034535	28	5						100001	2	15	
0034535	30	5		0068079	6	19		100001	8	13	
0034535	32	5		0068181	66	4		100001	21	5	
0034535	33	18		0068202	11	29		100001	26	14	
0034535	37	15						100001	28	14	
0034535	54	29		0091932	35	15		100001	30	17	
0034535	56	22						100001	31	5	
0034867	15	25		0092232	47	24		100001	36	19	
0034867	16	13		0092232	62	21		100001	41	11	
0034867	18	16		0092232	64	31		100001	47	19	
								100001	55	11	
0035719	47	9		0093303	4	30		100001	66	17	
0035719	49	9		0093363	31	43		100002	11	7	
0035722	41	15						100002	31	8	
0035722	47	12		0094491	41	1		100007	8	2	
0035722	49	12		0094491	47	4		100020	8	47	
0035722	50	5		0094491	49	4					
0035722	55	15		0094491	50	9		110001	3	8	
0035722	62	26		0094491	55	1		110001	6	29	
				0094491	59	23		110001	31	14	
0036091	63	29		0094546	35	22		110001	41	18	

INDEX

Page = 8

Parts No.	Page No.	Ref. No.	Weight (g)	Parts No.	Page No.	Ref. No.	Weight (g)	Parts No.	Page No.	Ref. No.	Weight (g)
110001	55	18		110013	47	13		110065	8	27	
110002	6	36		110013	50	2		110068	38	23	
110003	2	28		110013	54	5		110068	40	23	
110003	34	11		110013	55	2		110070	12	17	
110004	7	15		110013	62	2		110071	9	17	
110004	12	24		110013	64	15		110071	27	29	
110006	6	18		110013	69	32		110071	29	29	
110009	3	30		110015	69	30		110071	36	25	
110009	4	29		110016	1	17		110074	34	14	
110009	6	27		110016	11	43		110075	34	16	
110009	9	12		110016	13	4		110102	41	19	
110009	10	14		110016	46	4		110102	50	14	
110009	16	55		110016	48	4		110102	55	19	
110009	20	18		110017	11	46		110103	63	21	
110009	31	42		110022	46	17					
110009	35	29		110022	48	17		120001	6	2	
110009	54	20		110026	12	26		120001	7	2	
110009	56	13		110029	4	20		120001	9	2	
110009	63	2		110030	4	40		120001	10	2	
110010	1	13		110031	31	25		120001	34	6	
110010	8	14		110033	11	26		120006	6	6	
110010	66	16		110035	4	33		120006	7	6	
110011	6	33		110035	7	12		120006	9	5	
110011	63	30		110035	63	32		120006	10	5	
110012	1	11		110036	5	16		120006	11	4	
110012	2	7		110036	10	17		120006	62	1	
110012	3	13		110038	15	8		120008	9	10	
110012	4	35		110039	46	25		120009	34	23	
110012	7	20		110039	48	25		120010	8	20	
110012	8	8		110042	12	33		120011	7	17	
110012	14	10		110042	38	32		120013	35	2	
110012	17	25		110042	40	32		120013	46	6	
110012	19	23		110042	46	41-1		120013	48	6	
110012	21	2		110042	49	22		120017	1	28	
110012	26	11		110044	16	50		120017	8	23	
110012	28	11		110044	54	17		120018	34	4	
110012	30	14		110044	56	11		120018	46	23	
110012	41	4		110045	1	5		120018	48	23	
110012	49	19		110046	7	28					
110012	54	4		110047	15	50		130001	9	16	
110012	55	4		110047	16	38		130001	27	28	
110013	2	2		110047	18	41		130001	29	28	
110013	3	11		110047	31	10		130001	36	24	
110013	4	17		110047	37	25		130002	12	7	
110013	6	41		110047	59	53		130003	12	35	
110013	13	10		110048	3	3		130003	47	3	
110013	17	26		110048	41	9		130003	49	3	
110013	19	24		110048	46	36		130007	4	15	
110013	21	4		110048	47	17					
110013	26	13		110048	48	36		140000	11	17	
110013	28	13		110048	55	9		140001	11	11	
110013	30	16		110049	66	10		140002	10	12	
110013	34	12		110050	46	41-2		140002	27	33	
110013	36	18		110054	2	4		140002	29	33	
110013	41	2		110064	12	28		140003	6	13	

INDEX

Page = 7

Parts No.	Page No.	Ref. No.	Weight (g)	Parts No.	Page No.	Ref. No.	Weight (g)	Parts No.	Page No.	Ref. No.	Weight (g)
0033807	57	5		0036092	63	24		0094547	35	23	
0033807	58	5		0036111	59	21		0094548	35	14	
0033890	43	3		0036132	59	22		0094549	35	16	
0033890	44	3		0036133	41	10		0094553	35	20	
0033890	52	3		0036133	47	18		0094556	35	19	
0033890	53	3		0036133	55	10		0094557	35	21	
0033890	57	3		0036133	59	33		0094562	31	39	
0033890	58	3		0036133	64	33					
0033932	41	32		0036161	60	9		0095068	35	10	
0033932	49	24		0036518	3	23		0095069	35	13	
0033934	45	21		0036816	35	5		0095072	35	12	
0033935	45	18		0036820	35	1					
0033936	45	17		0036822	36	7-1		0099030	69	16	
0033937	45	16		0036827	35	11		0099031	69	17	
0033937	66	7		0036853	43	9		0099057	69	2	
0033938	45	14		0036853	44	9		0099058	69	3	
0033938	66	5		0036853	52	9		0099059	69	4-2	
0033939	41	31		0036853	53	9		0099060	69	4-1	
0033939	45	2		0036853	57	9		0099061	69	7	
0033939	49	23		0036853	58	9		0099062	69	10	
0033939	67	22		0036905	16	54		0099063	69	13	
0033940	45	24		0036905	54	19		0099064	69	18	
0033953	45	13		0036905	58	12		0099065	69	20	
0033968	6	39						0099066	69	21	
				0037114	17	14		0099067	69	23	
0034257	36	7-2		0037114	61	14		0099068	69	24	
0034535	8	42		0037372	6	20		0099069	69	25	
0034535	19	19		0037668	14	16		0099070	69	28-1	
0034535	20	8		0037669	14	2		0099071	69	28-2	
0034535	21	28						0099072	69	1-1	
0034535	23	15		0038805	36	10		0099073	69	1-2	
0034535	24	33		0038806	36	11					
0034535	25	17						100000	11	40	
0034535	26	27		0060248	50	1		100001	1	12	
0034535	28	5						100001	2	15	
0034535	30	5		0068079	6	19		100001	8	13	
0034535	32	5		0068181	66	4		100001	21	5	
0034535	33	18		0068202	11	29		100001	26	14	
0034535	37	15						100001	28	14	
0034535	54	29		0091932	35	15		100001	30	17	
0034535	56	22						100001	31	5	
0034867	15	25		0092232	47	24		100001	36	19	
0034867	16	13		0092232	62	21		100001	41	11	
0034867	18	16		0092232	64	31		100001	47	19	
								100001	55	11	
0035719	47	9		0093303	4	30		100001	66	17	
0035719	49	9		0093863	31	43		100002	11	7	
0035722	41	15						100002	31	8	
0035722	47	12		0094491	41	1		100007	8	2	
0035722	49	12		0094491	47	4		100020	8	47	
0035722	50	5		0094491	49	4					
0035722	55	15		0094491	50	9		110001	3	8	
0035722	62	26		0094491	55	1		110001	6	29	
				0094491	59	23		110001	31	14	
0036091	63	29		0094546	35	22		110001	41	18	

INDEX

Page = 8

Parts No.	Page No.	Ref. No.	Weight (g)	Parts No.	Page No.	Ref. No.	Weight (g)	Parts No.	Page No.	Ref. No.	Weight (g)
110001	55	18		110013	47	13		110065	8	27	
110002	6	36		110013	50	2		110068	38	23	
110003	2	28		110013	54	5		110068	40	23	
110003	34	11		110013	55	2		110070	12	17	
110004	7	15		110013	62	2		110071	9	17	
110004	12	24		110013	64	15		110071	27	29	
110006	6	18		110013	69	32		110071	29	29	
110009	3	30		110015	69	30		110071	36	25	
110009	4	29		110016	1	17		110074	34	14	
110009	6	27		110016	11	43		110075	34	16	
110009	9	12		110016	13	4		110102	41	19	
110009	10	14		110016	46	4		110102	50	14	
110009	16	55		110016	48	4		110102	55	19	
110009	20	18		110017	11	46		110103	63	21	
110009	31	42		110022	46	17					
110009	35	29		110022	48	17		120001	6	2	
110009	54	20		110026	12	26		120001	7	2	
110009	56	13		110029	4	20		120001	9	2	
110009	63	2		110030	4	40		120001	10	2	
110010	1	13		110031	31	25		120001	34	6	
110010	8	14		110033	11	26		120006	6	6	
110010	66	16		110035	4	33		120006	7	6	
110011	6	33		110035	7	12		120006	9	5	
110011	63	30		110035	63	32		120006	10	5	
110012	1	11		110036	5	16		120006	11	4	
110012	2	7		110036	10	17		120006	62	1	
110012	3	13		110038	15	8		120008	9	10	
110012	4	35		110039	46	25		120009	34	23	
110012	7	20		110039	48	25		120010	8	20	
110012	8	8		110042	12	33		120011	7	17	
110012	14	10		110042	38	32		120013	35	2	
110012	17	25		110042	40	32		120013	46	6	
110012	19	23		110042	46	41-1		120013	48	6	
110012	21	2		110042	49	22		120017	1	28	
110012	26	11		110044	16	50		120017	8	23	
110012	28	11		110044	54	17		120018	34	4	
110012	30	14		110044	56	11		120018	46	23	
110012	41	4		110045	1	5		120018	48	23	
110012	49	19		110046	7	28					
110012	54	4		110047	15	50		130001	9	16	
110012	55	4		110047	16	38		130001	27	28	
110013	2	2		110047	18	41		130001	29	28	
110013	3	11		110047	31	10		130001	36	24	
110013	4	17		110047	37	25		130002	12	7	
110013	6	41		110047	59	53		130003	12	35	
110013	13	10		110048	3	3		130003	47	3	
110013	17	26		110048	41	9		130003	49	3	
110013	19	24		110048	46	36		130007	4	15	
110013	21	4		110048	47	17					
110013	26	13		110048	48	36		140000	11	17	
110013	28	13		110048	55	9		140001	11	11	
110013	30	16		110049	66	10		140002	10	12	
110013	34	12		110050	46	41-2		140002	27	33	
110013	36	18		110054	2	4		140002	29	33	
110013	41	2		110064	12	28		140003	6	13	

INDEX

Parts No.	Page No.	Ref. No.	Weight (g)	Parts No.	Page No.	Ref. No.	Weight (g)	Parts No.	Page No.	Ref. No.	Weight (g)
140004	9	21		210005	28	20		390010	2	16	
140004	36	29		210005	30	10		390014	46	39	
140011	69	55		210005	39	16		390014	48	39	
140012	15	5		210005	51	14		390068	2	33	
140014	7	32						390070	2	32	
150001	3	14		270001	38	25		1050027	64	25	
				270001	40	25					
160000	5	14		280000	59	54		1057013	55	26	
160001	1	7						1057050	64	24	
160001	5	11		300000	11	10		1057086	50	19	
160001	8	33		300000	63	20					
160001	11	33		300004	1	27		1062000	46	3	
160001	12	3		300005	8	19		1062001	48	3	
160001	13	3		300007	41	20					
160001	31	17		300007	50	13		1066063	49	28	
160001	59	56		300007	55	20					
160002	6	4		300008	6	12		1070001	41	16	
160002	7	4		300008	9	20		1070001	55	16	
160002	9	23		300008	10	11					
160002	27	35		300008	27	32		1090035	64	10	
160002	29	35		300008	29	32		1090038	64	9	
160002	36	31		300008	36	28					
160003	6	8		300009	9	9		1091013	67	7-2	
160003	7	8		300027	69	14		1091025	63	15	
160003	10	8		300028	34	15		1091071	63	22	
160003	11	2						1091082	67	7-1	
160003	12	10		310001	6	46		1094008	67	25	
160005	5	39		310005	6	44		1094009	64	13	
160007	5	2		310009	5	29		1094011	45	3	
160007	8	26		310017	38	4		1094017	64	8	
160007	11	21		310017	40	4					
160007	12	2		310021	5	42		1095001	63	14	
160010	9	31		310023	13	14					
160010	27	43		310048	9	24		1096000	45	12	
160016	6	50		310048	27	36		1096004	45	25	
				310048	29	36		1096005	45	28	
				310048	36	32					
170000	8	11		310048	36	32		1097000	45	4	
170005	31	3		310049	9	28		1097001	45	9	
170031	31	7		310049	27	40					
170032	31	32		310049	29	40		1200001	50	4	
170034	34	8		310049	36	36		1200001	62	11	
				310051	6	16		1200004	47	1	
								1200005	49	1	
180001	8	6						1200008	41	14	
180002	12	16		320000	14	6		1200008	55	14	
180002	22	24		320001	14	7		1200009	41	13	
180003	12	21		320002	14	18		1200009	55	13	
180014	10	18		320003	14	19		1200011	41	12	
								1200011	55	12	
190001	11	41		330006	6	10		1200021	49	6	
190003	8	1		330011	9	26		1200182	60	12	
190046	34	10		330011	27	38					
				330011	29	38					
210005	21	18		330011	36	34					
210005	26	24		330014	1	33					

INDEX

Parts No.	Page No.	Ref. No.	Weight (g)	Parts No.	Page No.	Ref. No.	Weight (g)	Parts No.	Page No.	Ref. No.	Weight (g)
1200198	50	12		2100051	16	52		2100138	6	14	
1200202	50	3		2100051	18	9		2100140	6	17	
				2100052	15	19		2100142	13	13	
1249031	64	23		2100052	16	53		2100143	2	8	
				2100052	18	10		2100144	6	3	
1255174	63	8		2100053	1	16		2100145	6	32	
				2100054	1	18		2100148	6	38	
1260000	67	10		2100059	1	26		2100152	6	43	
1260062	64	14		2100060	4	28		2100160	7	1	
				2100062	4	14		2100161	7	7	
2020003	22	26		2100063	4	16		2100161	11	1	
				2100065	4	32		2100162	7	5	
2100001	1	19		2100071	4	19		2100164	7	11	
2100002	1	21		2100073	4	10		2100165	7	10	
2100003	1	20		2100074	23	9		2100166	7	27	
2100006	1	1		2100074	24	9		2100167	7	30	
2100008	1	10		2100074	25	9		2100168	7	31	
2100009	7	23		2100074	26	9		2100169	7	25	
2100011	1	6		2100074	27	9		2100170	7	22	
2100012	1	8		2100074	29	9		2100171	7	16	
2100013	1	2		2100074	33	9		2100172	7	19	
2100014	1	3		2100074	37	9		2100173	7	3	
2100017	2	11		2100076	17	24		2100174	7	24	
2100018	2	9		2100076	19	22		2100176	9	22	
2100019	2	10		2100076	54	3		2100176	27	34	
2100020	2	12		2100079	17	23		2100176	29	34	
2100021	7	21		2100079	19	21		2100176	36	30	
2100022	2	18		2100079	54	2		2100179	8	28	
2100024	2	24		2100080	3	32		2100181	8	3	
2100025	2	26		2100081	2	14		2100184	8	7	
2100027	15	9		2100082	41	36		2100186	8	10	
2100027	16	57		2100082	50	23		2100187	8	9	
2100027	18	43		2100082	55	31		2100188	8	31	
2100028	2	1		2100088	9	3		2100189	8	30	
2100029	3	27		2100088	10	3		2100190	8	29	
2100030	3	29		2100090	5	1		2100192	8	24	
2100032	13	11		2100092	5	6		2100193	8	17	
2100033	11	22		2100093	3	9		2100193	67	26	
2100034	5	37		2100095	5	17		2100194	8	15	
2100035	3	1		2100096	5	36		2100195	8	12	
2100036	3	2		2100104	5	21		2100197	8	21	
2100037	3	26		2100109	5	18		2100199	8	32	
2100038	3	25		2100110	3	24		2100201	9	4	
2100039	3	6		2100111	5	15		2100202	5	31	
2100041	3	21		2100112	5	19		2100204	9	7	
2100042	3	22		2100113	5	7		2100205	9	8	
2100043	3	18		2100114	5	33		2100210	10	4	
2100044	3	17		2100117	5	22		2100211	10	10	
2100045	3	16		2100120	5	12		2100215	9	1	
2100047	3	4		2100121	5	8		2100215	10	1	
2100048	2	5		2100122	3	10		2100218	10	6	
2100049	2	3		2100132	6	1		2100219	10	9	
2100050	15	17		2100134	6	5		2100221	9	19	
2100050	18	8		2100136	6	11		2100221	36	27	
2100051	15	18		2100137	6	7		2100226	9	14	

INDEX

Parts No.	Page No.	Ref. No.	Weight (g)	Parts No.	Page No.	Ref. No.	Weight (g)	Parts No.	Page No.	Ref. No.	Weight (g)
2100226	27	26		2100337	69	47		2100566	9	13	
2100226	29	26		2100338	69	48		2100567	9	18	
2100226	36	22		2100339	69	35		2100579	8	4	
2100227	9	15		2100341	14	17		2100580	8	5	
2100227	27	27		2100346	22	23		2100581	9	11	
2100227	29	27		2100347	22	25		2100586	4	38	
2100227	36	23		2100350	15	1		2100592	4	23	
2100229	4	27		2100352	15	6		2100601	11	42	
2100240	11	19		2100353	15	7		2100602	12	4	
2100241	11	14		2100354	15	4		2100603	12	1	
2100242	11	13		2100363	13	2		2100605	13	12	
2100243	11	15		2100364	5	10		2100606	4	34	
2100244	11	16		2100365	13	1		2100607	14	4	
2100245	11	23		2100370	5	32		2100609	5	35	
2100246	11	24		2100375	69	43		2100610	5	38	
2100247	11	25		2100376	69	33		2100611	8	25	
2100248	11	8		2100381	69	29		2100613	5	27	
2100249	11	9		2100382	69	31		2100614	5	28	
2100250	11	3		2100383	13	21		2100615	5	20	
2100251	11	5		2100384	14	15		2100617	5	34	
2100252	11	28		2100478	37	24		2100620	6	15	
2100253	11	30		2100501	5	13		2100621	5	51	
2100255	13	8		2100502	6	28		2100625	5	5	
2100256	11	35		2100503	6	24		2100626	14	1	
2100260	11	18		2100504	6	25		2100631	12	27	
2100262	11	31		2100506	9	25		2100632	12	29	
2100263	11	37		2100506	27	37		2100633	14	12	
2100265	11	44		2100506	29	37		2100634	14	11	
2100266	11	12		2100516	9	30		2100638	36	21	
2100267	11	32		2100516	27	42		2100639	36	26	
2100269	11	27		2100517	9	6		2100640	36	35	
2100272	5	30		2100518	8	22		2100641	34	22	
2100273	10	7		2100519	4	21		2100642	34	21	
2100275	12	14		2100520	4	18		2100643	36	33	
2100276	12	15		2100521	4	31		2100645	13	5	
2100277	12	12		2100522	10	13		2100646	13	7	
2100278	12	13		2100523	13	16					
2100279	12	20		2100524	4	39		2101011	38	24	
2100280	12	8		2100524	13	15		2101011	40	24	
2100281	12	6		2100525	3	5		2101020	15	30	
2100283	12	5		2100526	3	7		2101020	16	18	
2100284	12	9		2100532	6	37		2101020	18	21	
2100285	12	30		2100533	6	45		2101021	15	29	
2100286	12	31		2100534	2	27		2101021	15	17	
2100288	11	20		2100535	6	47		2101021	18	20	
2100289	12	18		2100536	6	48		2101022	15	44	
2100301	12	34		2100537	9	34		2101022	16	32	
2100302	12	32		2100537	65	3		2101022	18	35	
2100313	5	9		2100538	2	17		2101026	15	24	
2100314	13	20		2100540	6	9		2101026	16	12	
2100315	13	17		2100541	14	9		2101026	18	15	
2100316	13	18		2100546	14	14		2101027	15	23	
2100318	3	12		2100565	9	27		2101027	16	11	
2100325	14	8		2100565	27	39		2101027	18	14	
2100336	69	53		2100565	29	39		2101038	59	57	

INDEX

Parts No.	Page No.	Ref. No.	Weight (g)	Parts No.	Page No.	Ref. No.	Weight (g)	Parts No.	Page No.	Ref. No.	Weight (g)
2101040	62	9		2101124	55	17		2101254	31	40	
2101043	41	23		2101124	62	12		2101255	31	33	
2101043	62	10		2101131	46	38		2101257	31	38	
2101045	50	7		2101131	48	38		2101258	31	19	
2101045	55	23		2101133	16	40		2101259	31	16	
2101048	16	51		2101133	54	7		2101260	31	13	
2101050	54	18		2101133	56	1		2101268	31	45	
2101054	55	21-1		2101134	16	41		2101329	43	25	
2101055	55	21-2		2101134	54	8		2101329	52	25	
2101056	43	1		2101134	56	2		2101329	57	25	
2101056	57	1		2101136	46	26		2101330	44	25	
2101057	44	1		2101136	48	26		2101330	53	25	
2101057	58	1		2101137	46	14		2101330	58	25	
2101058	38	33		2101137	48	14		2101394	50	28	
2101058	40	33		2101138	41	3		2101395	60	29	
2101059	38	31		2101138	49	18		2101405	27	22	
2101059	40	31		2101138	55	3		2101405	29	22	
2101089	27	31		2101140	27	10		2101407	27	14	
2101089	29	31		2101140	29	10		2101407	29	14	
2101091	28	23		2101141	27	23		2101431	27	11	
2101100	46	5		2101141	29	23		2101431	29	11	
2101100	48	5		2101142	27	24		2101432	27	12	
2101101	46	1		2101142	29	24		2101432	29	12	
2101101	48	1		2101143	27	46		2101433	27	13	
2101103	46	16		2101143	29	46		2101433	29	13	
2101103	48	16		2101145	46	40-2		2101435	15	3	
2101104	46	15		2101146	27	25		2101450	69	38	
2101104	48	15		2101146	29	25		2101451	69	39	
2101105	46	11		2101147	27	30		2101452	41	8	
2101105	48	11		2101147	29	30		2101452	47	16	
2101106	46	10		2101148	43	22		2101452	55	8	
2101106	48	10		2101148	44	22		2101462	34	1	
2101107	46	19		2101148	52	22		2101463	34	18	
2101107	48	19		2101148	53	22		2101547	66	1	
2101108	46	22		2101148	57	22		2101548	66	8	
2101108	48	22		2101148	58	22		2101549	66	9	
2101109	46	7		2101171	46	18		2101550	66	15	
2101109	48	7		2101171	48	18		2101551	66	2	
2101113	41	21		2101182	17	22		2101570	34	7	
2101113	50	10		2101182	19	20		2101571	34	2	
2101115	49	21		2101182	54	1		2101572	34	9	
2101116	41	30		2101240	31	1		2101573	34	5	
2101116	50	22		2101241	31	6		2101574	34	13	
2101116	55	30		2101242	31	9		2101575	34	17	
2101117	52	1		2101243	31	2		2101576	34	20	
2101118	53	1		2101244	31	11		2101577	35	7	
2101119	46	24		2101245	31	15		2101578	35	28	
2101119	48	24		2101246	31	12		2101579	35	4	
2101121	46	21		2101247	31	26		2101580	35	9	
2101121	48	21		2101248	31	18		2101581	35	32	
2101122	46	40-1		2101249	31	22		2101582	35	33	
2101123	47	2		2101250	31	23		2101600	53	1	
2101123	49	2		2101251	31	41		2101601	63	11	
2101124	41	17		2101252	31	31		2101602	63	9	
2101124	50	6		2101253	31	35		2101603	63	16	

KNIFE DRIVING MECHANISM

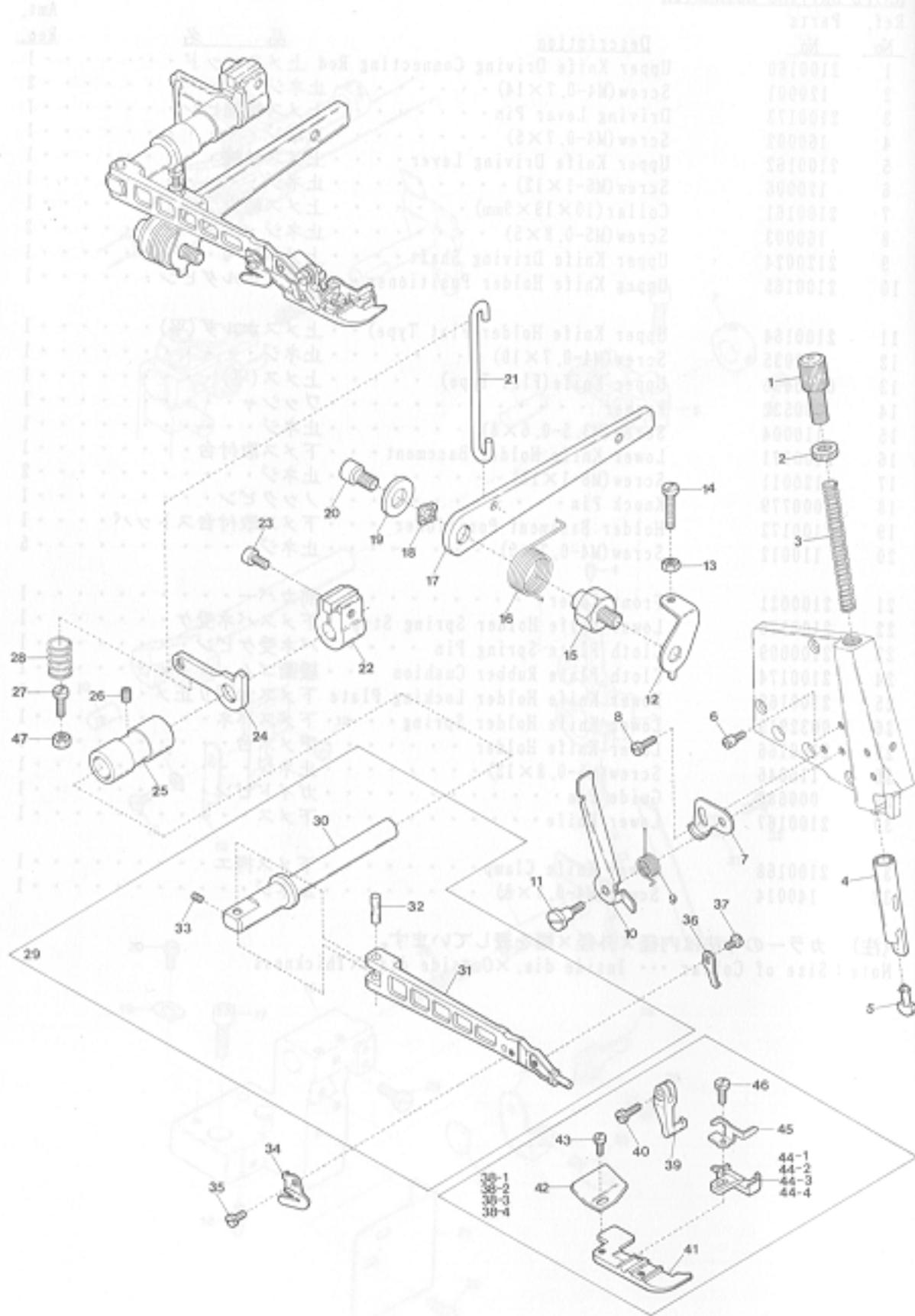

PRESSER FOOT MECHANISM

Ref. No.	Parts No.	Description	品名	Ant. Req.
1	190003	Adjusting Screw(M10-0.75×30)	調節ネジ	1
2	100007	Lock Nut	ロックナット	1
3	2100181	Presser Spring	押エバネ	1
4	2100579	Presser Bar	押エ棒	1
5	2100580	Presser Arm Positioning Guide Pin	押エ腕案内ピン	1
6	180001	Screw(M4-0.7×4.5)	バネ掛ケネジ	1
7	2100184	Presser Arm Stop	押エ腕ストッパ	1
8	110012	Screw(M4-0.7×5)	止ネジ	1
9	2100187	Presser Foot Release Lever Spring	手揚ゲバネ	1
10	2100186	Presser Foot Release Lever	手揚ゲ	1
11	170000	Screw(M4-0.7×13)	止ネジ	1
12	2100195	Presser Foot Lifter Lever Stop	押エ揚ゲレバーストッパ	1
13	100001	Lock Nut	ロックナット	1
14	110010	Stop Screw(M4-0.7×16)	ストップネジ	1
15	2100194	Lifter Lever Holder	押エ揚ゲレバー取付台	1
16	2110361	Presser Foot Lifter Lever Spring	押エ揚ゲレバーバネ	1
17	2100193	Presser Foot Lifter Lever	押エ揚ゲレバー	1
18	000487	Corrugeted Washer	波形ワッシャ	1
19	300005	Washer	ワッシャ	1
20	120010	Screw(M6-1×10)	止ネジ	1
21	2100197	Presser Foot Lifter Lever Link	押エ揚ゲレバーリンク	1
22	2100518	Presser Foot Shaft Collar	押エ軸カラー	1
23	120017	Screw(M5-0.8×15)	止ネジ	1
24	2100192	Intermediate Lever	押エ軸レバー	1
25	2100511	Presser Foot Shaft Bushing	押エ軸ブッシュ	1
26	160007	Screw(M6-1×6)	止ネジ	1
27	110065	Stop Screw(M4-0.7×12)	ストップネジ	1
28	2100179	Intermediate Lever Spring	押エ軸レバーバネ	1
29	2100190	Presser Arm, Complete Set	押エ腕(組)	1
30	2100189	Presser Foot Shaft	押エ軸	1
31	2100188	Presser Arm	押エ腕	1
32	2100199	Presser Arm Hinge Pin	押エ腕ヒンジピン	1
33	160001	Screw(M4-0.7×4)	止ネジ	1
34	0020271	Thread Chain Cutting Knife	チェーンカッタ	1
35	004097	Screw(3/32-56×4.2)	止ネジ	1
36	0021015	Presser Foot Half-stay	半固定片	1
37	004096	Screw(1/8-44×4.5)	止ネジ	1
38-1	2107300	Presser Foot, Complete Set (03)	押エ(組) (03)	1
38-2	2107301	" " (04)	" (04)	1
38-3	2107302	" " (05)	" (05)	1
38-4	2107303	" " (06)	" (06)	1
39	0024100	Presser Foot Hinge	押エヒンジ	1
40	004351	Screw(9/64-40×7)	止ネジ	1
41	2107280	Presser Foot(Lower)	押エ(下)	1
42	0034535	Presser Foot Chain Shield	空糸押エ	1
43	004237	Screw(3/32-56×2.6)	止ネジ	1
44-1	2107220	Presser Foot Stitch Tongue(03)	爪(03)	1
44-2	2107221	" " (04)	" (04)	1
44-3	2107222	" " (05)	" (05)	1
44-4	2107223	" " (06)	" (06)	1
45	2107162	Presser Foot Hinge Spring	押エヒンジバネ	1
46	005036	Screw(1/8-44×5.6)	止ネジ	1
47	100020	Lock Nut	ロックナット	1

INDEX

Page = 11

Parts No.	Page No.	Ref. No.	Weight (g)	Parts No.	Page No.	Ref. No.	Weight (g)	Parts No.	Page No.	Ref. No.	Weight (g)
2100226	27	26		2100337	69	47		2100566	9	13	
2100226	29	26		2100338	69	48		2100567	9	18	
2100226	36	22		2100339	69	35		2100579	8	4	
2100227	9	15		2100341	14	17		2100580	8	5	
2100227	27	27		2100346	22	23		2100581	9	11	
2100227	29	27		2100347	22	25		2100586	4	38	
2100227	36	23		2100350	15	1		2100592	4	23	
2100229	4	27		2100352	15	6		2100601	11	42	
2100240	11	19		2100353	15	7		2100602	12	4	
2100241	11	14		2100354	15	4		2100603	12	1	
2100242	11	13		2100363	13	2		2100605	13	12	
2100243	11	15		2100364	5	10		2100606	4	34	
2100244	11	16		2100365	13	1		2100607	14	4	
2100245	11	23		2100370	5	32		2100609	5	35	
2100246	11	24		2100375	69	43		2100610	5	38	
2100247	11	25		2100376	69	33		2100611	8	25	
2100248	11	8		2100381	69	29		2100613	5	27	
2100249	11	9		2100382	69	31		2100614	5	28	
2100250	11	3		2100383	13	21		2100615	5	20	
2100251	11	5		2100384	14	15		2100617	5	34	
2100252	11	28		2100478	37	24		2100620	6	15	
2100253	11	30		2100501	5	13		2100621	6	51	
2100255	13	9		2100502	6	28		2100625	5	5	
2100256	11	35		2100503	6	24		2100626	14	1	
2100260	11	18		2100504	6	25		2100631	12	27	
2100262	11	31		2100506	9	25		2100632	12	29	
2100263	11	37		2100506	27	37		2100633	14	12	
2100265	11	44		2100506	29	37		2100634	14	11	
2100266	11	12		2100516	9	30		2100638	36	21	
2100267	11	32		2100516	27	42		2100639	36	26	
2100269	11	27		2100517	9	6		2100640	36	35	
2100272	5	30		2100518	8	22		2100641	34	22	
2100273	10	7		2100519	4	21		2100642	34	21	
2100275	12	14		2100520	4	18		2100643	36	33	
2100276	12	15		2100521	4	31		2100645	13	5	
2100277	12	12		2100522	10	13		2100646	13	7	
2100278	12	13		2100523	13	16					
2100279	12	20		2100524	4	39		2101011	38	24	
2100280	12	8		2100524	13	15		2101011	40	24	
2100281	12	6		2100525	3	5		2101020	15	30	
2100283	12	5		2100526	3	7		2101020	16	18	
2100284	12	9		2100532	6	37		2101020	18	21	
2100285	12	30		2100533	6	45		2101021	15	29	
2100286	12	31		2100534	2	27		2101021	16	17	
2100288	11	20		2100535	6	47		2101021	18	20	
2100289	12	18		2100536	6	48		2101022	15	44	
2100301	12	34		2100537	9	34		2101022	16	32	
2100302	12	32		2100537	65	3		2101022	18	35	
2100312	5	9		2100538	2	17		2101026	15	24	
2100314	13	20		2100540	6	9		2101026	16	12	
2100315	13	17		2100541	14	9		2101026	18	15	
2100316	13	18		2100546	14	14		2101027	15	23	
2100318	3	12		2100565	9	27		2101027	16	11	
2100325	14	8		2100565	27	39		2101027	18	14	
2100336	69	53		2100565	29	39		2101038	59	57	

INDEX

Page = 12

Parts No.	Page No.	Ref. No.	Weight (g)	Parts No.	Page No.	Ref. No.	Weight (g)	Parts No.	Page No.	Ref. No.	Weight (g)
2101040	62	9		2101124	55	17		2101254	31	40	
2101043	41	23		2101124	62	12		2101255	31	33	
2101043	62	10		2101131	46	38		2101257	31	38	
2101045	50	7		2101131	48	38		2101258	51	19	
2101045	55	23		2101133	16	40		2101259	31	16	
2101048	16	51		2101133	54	7		2101260	31	13	
2101050	54	18		2101133	56	1		2101268	31	45	
2101054	55	21-1		2101134	16	41		2101329	43	25	
2101055	55	21-2		2101134	54	8		2101329	52	25	
2101056	43	1		2101134	56	2		2101329	57	25	
2101056	57	1		2101136	46	26		2101330	44	25	
2101057	44	1		2101136	48	26		2101330	53	25	
2101057	58	1		2101137	46	14		2101330	58	25	
2101058	38	33		2101137	48	14		2101394	60	28	
2101058	40	33		2101138	41	3		2101395	60	29	
2101059	38	31		2101138	49	18		2101405	27	22	
2101059	40	31		2101138	55	3		2101405	29	22	
2101089	27	31		2101140	27	10		2101407	27	14	
2101089	29	31		2101140	29	10		2101407	29	14	
2101091	28	23		2101141	27	23		2101431	27	11	
2101100	46	5		2101141	29	23		2101431	29	11	
2101100	48	5		2101142	27	24		2101432	27	12	
2101101	46	1		2101142	29	24		2101432	29	12	
2101101	48	1		2101143	27	46		2101433	27	13	
2101103	46	16		2101143	29	46		2101433	29	13	
2101103	48	16		2101145	46	40-2		2101435	15	3	
2101104	46	15		2101146	27	25		2101450	69	38	
2101104	48	15		2101146	29	25		2101451	69	39	
2101105	46	11		2101147	27	30		2101452	41	8	
2101105	48	11		2101147	29	30		2101452	47	16	
2101106	46	10		2101148	43	22		2101452	55	8	
2101106	48	10		2101148	44	22		2101462	34	1	
2101107	46	19		2101148	52	22		2101463	34	18	
2101107	48	19		2101148	53	22		2101547	66	1	
2101108	46	22		2101148	57	22		2101548	66	8	
2101108	48	22		2101148	58	22		2101549	66	9	
2101109	46	7		2101171	46	18		2101550	66	15	
2101109	48	7		2101171	48	18		2101551	66	2	
2101113	41	21		2101182	17	22		2101570	34	7	
2101113	50	10		2101182	19	20		2101571	34	2	
2101115	49	21		2101182	54	1		2101572	34	9	
2101116	41	30		2101240	31	1		2101573	34	5	
2101116	50	22		2101241	31	6		2101574	34	13	
2101116	55	30		2101242	31	9		2101575	34	17	
2101117	52	1		2101243	31	2		2101576	34	20	
2101118	53	1		2101244	31	11		2101577	35	7	
2101119	45	24		2101245	31	15		2101578	35	28	
2101119	48	24		2101246	31	12		2101579	35	4	
2101121	45	21		2101247	31	26		2101580	35	9	
2101121	48	21		2101248	31	18		2101581	35	32	
2101122	46	40-1		2101249	31	22		2101582	35	33	
2101123	47	2		2101250	31	23		2101600	63	1	
2101123	49	2		2101251	31	41		2101601	63	11	
2101124	41	17		2101252	31	31		2101602	63	9	
2101124	50	6		2101253	31	35		2101603	63	16	

INDEX

Page = 13

Parts No.	Page No.	Ref. No.	Weight (g)	Parts No.	Page No.	Ref. No.	Weight (g)	Parts No.	Page No.	Ref. No.	Weight (g)
2101604	63	19		2107162	23	18		2107230	51	18-1	
2101605	63	28		2107162	25	20		2107231	23	17-3	
2101606	63	25		2107162	26	22		2107231	39	11-2	
2101607	63	23		2107162	28	8		2107231	42	11-2	
2101608	63	26		2107162	30	8		2107231	51	18-2	
2101609	63	41		2107162	33	16		2107232	23	25-1	
2101610	63	43		2107162	39	6		2107232	39	11-3	
2101611	63	44		2107162	42	6		2107232	42	11-3	
2101612	63	34		2107162	51	6		2107232	51	18-3	
2101613	63	33		2107162	54	27		2107233	23	25-2	
2101614	65	1		2107162	56	20		2107233	39	11-4	
2101615	65	2		2107173	21	17		2107233	42	11-4	
2101616	63	7		2107173	26	23		2107234	25	19	
				2107173	28	19		2107238	26	34	
2107000	15	14-1		2107173	30	9		2107238	39	14-3	
2107000	20	5-2		2107173	39	15		2107238	51	20-3	
2107004	15	14-2		2107173	51	13		2107240	26	21-1	
2107004	16	5		2107174	21	19		2107240	28	18-1	
2107004	18	5		2107174	26	25		2107240	39	14-1	
2107006	19	5-1		2107174	28	21		2107240	51	20-1	
2107008	19	5-2		2107174	30	11		2107241	26	21-2	
2107009	19	5-3		2107174	39	17		2107241	28	18-2	
2107011	24	14-1		2107174	51	15		2107241	39	14-2	
2107017	24	25-1		2107198	37	18		2107241	51	20-2	
2107019	24	14-2		2107203	36	5-1		2107242	28	18-3	
2107020	19	5-4		2107219	21	21		2107242	30	7	
2107023	24	25-2		2107219	39	8		2107243	19	16	
2107030	15	13		2107219	42	8		2107243	39	21-1	
2107030	16	4		2107220	8	44-1		2107244	28	7-1	
2107030	18	4		2107220	39	5-1		2107245	28	7-2	
2107031	15	10-1		2107220	42	5-1		2107246	28	7-3	
2107032	15	10-2		2107220	51	5-1		2107247	56	28-1	
2107032	16	1		2107221	8	44-2		2107250	33	26	
2107032	18	1		2107221	39	5-2		2107253	20	5-3	
2107036	19	4-1		2107221	42	5-2		2107254	20	5-1	
2107037	19	4-3		2107221	51	5-2		2107255	20	5-4	
2107037	24	13-1		2107222	8	44-3		2107256	20	16	
2107039	24	30		2107222	39	5-3		2107257	56	28-2	
2107039	39	20-2		2107222	42	5-3		2107278	37	14	
2107042	24	31		2107222	51	5-3		2107279	36	4	
2107042	39	21-2		2107223	8	44-4		2107280	8	41	
2107044	24	28		2107223	39	5-4		2107280	23	14-2	
2107045	21	24		2107223	42	5-4		2107280	39	4	
2107046	21	25		2107223	51	5-4		2107280	42	4	
2107063	21	23		2107224	39	24-1		2107280	51	4	
2107068	33	15-1		2107224	54	26-1		2107280	54	25	
2107069	33	11-1		2107224	56	19-1		2107280	56	18	
2107084	22	1		2107225	39	24-2		2107282	25	16	
2107085	22	2		2107225	54	26-2		2107284	28	17	
2107162	8	45		2107225	56	19-2		2107284	30	4	
2107162	15	15		2107226	21	15		2107286	19	15	
2107162	16	6		2107229	37	17		2107286	39	20-1	
2107162	18	6		2107230	23	17-2		2107289	28	4	
2107162	20	6		2107230	39	11-1		2107290	21	14	
2107162	21	16		2107230	42	11-1		2107290	26	20	

INDEX

Page = 14

Parts No.	Page No.	Ref. No.	Weight (g)	Parts No.	Page No.	Ref. No.	Weight (g)	Parts No.	Page No.	Ref. No.	Weight (g)
2107290	39	13		2107350	19	1-1		2108021	24	37	
2107290	51	11		2107351	19	1-2		2108024	19	11-1	
2107291	20	4		2107352	19	1-3		2108026	19	11-3	
2107300	8	38-1		2107353	19	1-4		2108026	36	13-2	
2107301	8	38-2		2107354	24	23-1		2108027	19	11-4	
2107302	8	38-3		2107355	24	23-2		2108030	25	22	
2107303	8	38-4		2107356	24	10-1		2108032	16	8	
2107305	36	1-3		2107357	24	10-2		2108043	28	24-1	
2107306	26	33		2107358	39	19-1		2108044	28	24-2	
2107308	26	17-1		2107359	39	19-2		2108045	28	24-3	
2107309	26	17-2		2107361	39	12-3		2108062	27	18-1	
2107310	23	11-2		2107363	39	12-1		2108063	27	18-2	
2107311	23	11-3		2107364	39	12-2		2108064	27	18-3	
2107312	23	24-1		2107370	21	11		2108100	18	11	
2107313	23	24-2		2107372	39	23-1		2108110	20	10-2	
2107314	25	13		2107373	39	23-2		2108111	20	10-3	
2107317	54	22-1		2107385	36	1-1		2108112	20	10-1	
2107317	56	15-1		2107386	36	1-2		2108113	20	10-4	
2107318	54	22-2		2107389	33	25		2108114	20	13	
2107318	56	15-2		2107390	33	11-2		2108115	20	14	
2107319	56	27-1		2107393	20	1		2108116	20	12	
2107320	51	1-1		2107397	37	11		2108118	37	22	
2107321	51	1-2		2107398	56	27-2		2108119	56	29-2	
2107322	51	1-3						2108120	23	22-1	
2107323	51	1-4		2108000	15	20-2					
2107324	51	17-1		2108001	15	20-1		2109000	15	21	
2107325	51	17-2		2108002	6	30-1		2109000	16	9	
2107326	51	17-3		2108003	6	30-2		2109000	18	12	
2107328	51	19-3		2108004	23	22-2		2109001	15	22	
2107330	51	19-1		2108004	24	21-1		2109001	16	10	
2107331	51	19-2		2108004	26	31-1		2109001	18	13	
2107332	28	16-1		2108004	33	22-1		2109005	12	22-2	
2107333	28	16-2		2108005	23	22-3		2109005	36	14	
2107334	28	16-3		2108005	24	21-2		2109006	12	23	
2107334	30	1		2108005	26	31-2		2109007	12	22-1	
2107335	39	1-1		2108005	33	22-2		2109007	20	11	
2107335	42	1-1		2108006	23	27-1		2109009	12	22-3	
2107336	39	1-2		2108006	24	27-1		2109009	23	23	
2107336	42	1-2		2108006	26	36		2109009	24	22	
2107337	39	1-3		2108006	33	28		2109009	26	32	
2107337	42	1-3		2108007	6	30-3		2109009	29	19	
2107338	39	1-4		2108008	54	31-2		2109010	21	8	
2107338	42	1-4		2108008	56	24-2		2109010	54	32	
2107339	39	10-1		2108009	21	7		2109010	56	25	
2107339	42	10-1		2108010	19	11-2		2109011	21	9	
2107340	39	10-2		2108010	36	13-1		2109011	54	33	
2107340	42	10-2		2108011	54	31-1		2109011	56	26	
2107341	39	10-3		2108011	56	24-1		2109015	56	30	
2107341	42	10-3		2108012	6	30-4		2109016	56	31	
2107342	39	10-4		2108013	56	29-1		2109017	22	17	
2107342	42	10-4		2108014	23	27-2		2109018	22	18	
2107346	19	13		2108014	24	27-2		2109019	22	19	
2107347	28	1-1		2108015	22	13		2109020	32	10	
2107348	28	1-2		2108016	22	11		2109020	33	23-1	
2107349	28	1-3		2108017	22	12		2109021	32	11	

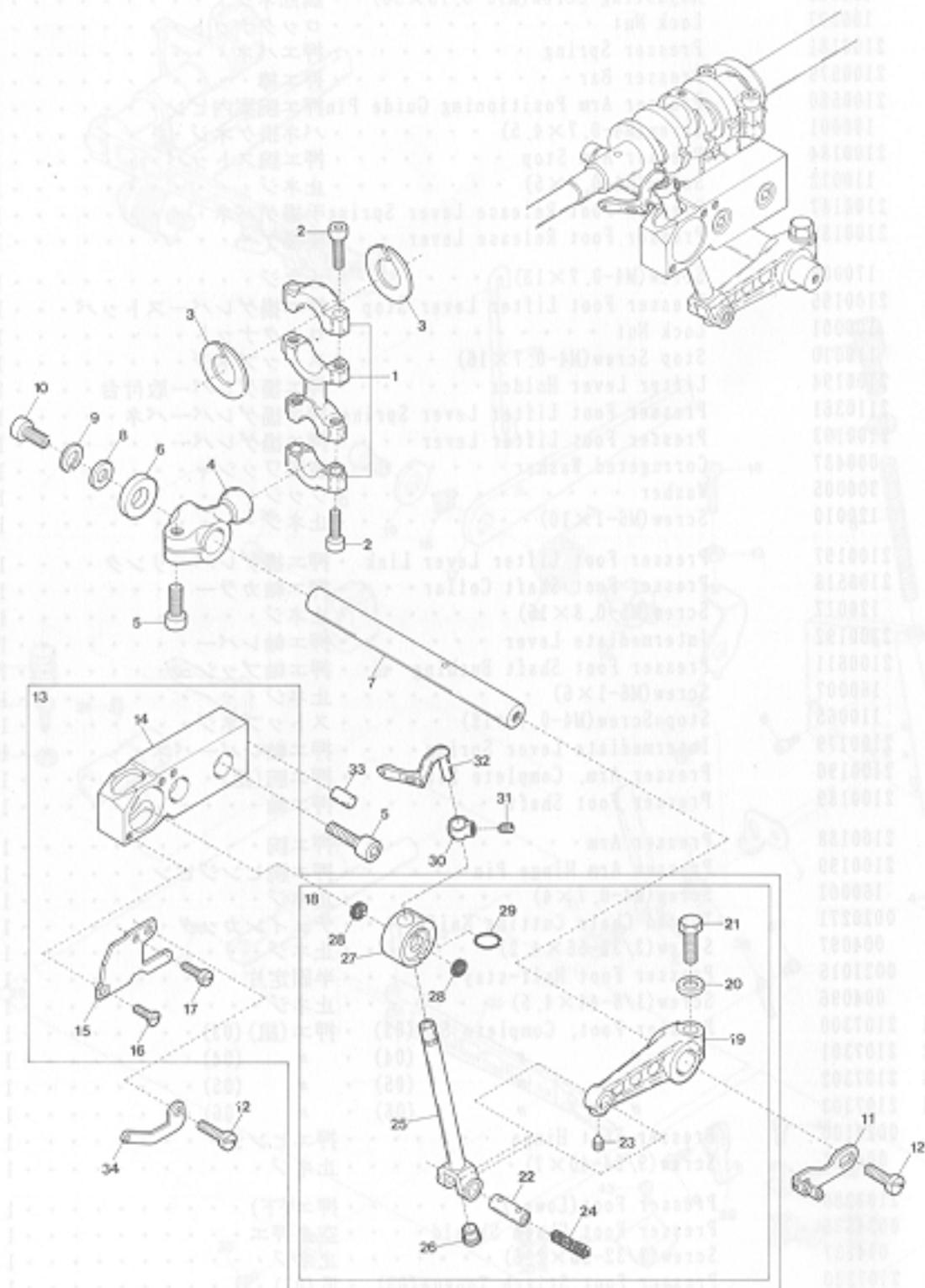

UPPER LOOPER DRIVING MECHANISM

Ref. No.	Parts No.	Description	品名	9
1	2100215	Looper Driving Lever Connecting Rod	ルーパーバロッド	1
2	120001	Screw(M4-0.7×14)	止ネジ	4
3	2100088	Connecting Rod Swing-proof	振レ止メ	2
4	2100201	Upper Looper Driving Lever	上ルーパー軸腕	1
5	120006	Screw(M6-1×12)	止ネジ	3
6	2100517	Driving Shaft Thrust Ring	スラストリング	1
7	2100204	Looper Driving Shaft	上ルーパー軸	1
8	2100205	Driving Shaft Thrust Ring	スラストリング	1
9	300009	Spring Washer	スプリングワッシャ	1
10	120008	Screw(M4-0.7×8)	止ネジ	1
11	2100581	Upper Looper Thread Pull-off	上ルーパー糸繰り	1
12	110009	Screw(M4-0.7×8)	止ネジ	2
13	2100566	Upper Looper Bar Crank Arm, C. Set	上ルーパー crank (組)	1
14	2100226	Upper Looper Bar Guide Bushing	ルーパー案内メタル	1
15	2100227	Upper Looper Bar Guide Cover	ルーパー案内蓋	1
16	130001	Screw(M2.5-0.45×6)	止ネジ	1
17	110071	Screw(M2.5-0.45×6)	止ネジ	1
18	2100567	Upper Looper Bar Guide, Complete Set	ルーパー案内 (組)	1
19	2100221	Upper Looper Bar Crank Arm	上ルーパー crank	1
20	300008	Washer	ワッシャ	1
21	140004	Screw(M6-1×16)	止ネジ	1
22	2100176	Upper Looper Bar Crank Arm Pin	上ルーパー crank ピン	1
23	160002	Screw(M4-0.7×5)	止ネジ	1
24	310048	Oil Wick	油芯	1
25	2100506	Upper Looper Bar Unit	ルーパー棒 (組)	1
26	330011	Seal Plug	詰栓	1
27	2100565	Upper Looper Bar Guide	ルーパー案内	1
28	310049	Oiling Felt	フェルト	2
29	0020538	O-ring(P7)	Oリング	1
30	2100516	Upper Looper Holder Collar	上ルーパー止メカラー	1
31	160010	Screw(M4-0.7×3)	止ネジ	1
32	2109320	Upper Looper(for Needle Size #9~14)	上ルーパー (針番手#9~14用)	1
33	000779	Standard Pin	基準ピン	1
34	2100537	Upper Looper Supplementary Thread Eyelet	上ルーパー補助糸道	1