

Yamato[®]

Instruction Manual

ELECTRIC UNDER THREAD TRIMMING DEVICE
ELECTRIC TOP COVER THREAD TRIMMING DEVICE

UT

UT-2, UT-4/ST2

VC2700M class

Thank you for having purchased UT device.
Before using your UT device, please read the instruction manual and understand the contents well.
After reading the instruction manual, please keep it in a location where it is easily accessible to the operator.

CONTENTS

1. Proper operation	1
1.1 Operating procedure for UT-2 device	1
1.2 Operating procedure for UT-4/ST device	2
2. Wiring	3
2.1 Detector switch	3
2.1.1 Adjusting detector switch	3
2.1.2 Connecting detector switch	3
2.2 Connecting solenoid	4
3. Installing synchronizer	5
4. Adjusting thread trimming mechanism	6
4.1 Installing plunger rod	6
4.2 Stroke of solenoid	6
4.3 Solenoid return spring	6
4.4 Position of lower knife	7
4.5 Relation between upper and lower knives	7
4.6 Positions of clamp spring and clamp spring presser	8
4.7 Pressure of clamp spring	8
4.8 Position of upper knife carrier	8
4.9 Relation between lower knife and needle	9
4.10 Position of lower knife tip	10
4.11 Lower knife carrier guide	11
4.12 Lower knife carrier guide(upper)	11
4.13 Relation between lower knife and needle thread or looper thread	13

CONTENTS

5. Adjusting tension release mechanism	13
5.1 Tension release block	13
5.2 Tension release connecting plate	13
5.3 Thread pull-off lever	13
5.4 Looper thread pull-off (option)	14
5.5 Tension disc separator	15
5.6 Thread pull-off hook unit	15
6. Adjusting wiper	16
6.1 Wiper and needles	16
6.2 Distance of wiper	16
6.3 Wiper and thread clamp rubber	16
6.4 Standard position of solenoid support	17
6.5 Standard position of solenoid lever	17
6.6 Standard position of wiper	17
7. Presser foot lifter mechanism	18
8. ST2 device	19
8.1 Position of movable trimming knife	19
8.2 Engagement between movable and fixed trimming knives	20
8.3 Adjusting stroke of movable trimming knife	21
8.4 Pressure of thread clamp spring	21
8.5 Adjusting spring	22
8.6 Adjusting thread pull-off hook unit	22

Attention

The description in this instruction manual is subject to change for improvements of the commodity without notice.

1. Proper operation

⚠ CAUTION

Be sure to place a fabric under the presser foot when operating.

1.1 Operating procedure for UT-2 device

The motor can be selected 1 position or 2 position. The operating procedure for 1 position and 2 position is mentioned below.

- (1) Place a fabric under the presser foot and toe down the pedal. (Fig. 1 ①)

The machine starts sewing.

- (2) Release the pedal. (Fig. 1 ②)

The needle stops at the lowest point.

(Skip this procedure when 1 position is selected.)

- (3) Heel back the pedal. (Fig. 1 ③)

The needle rises and stops at the highest point.

The trimming knife mechanism operates to cut the needle and the looper threads under the stitch plate. The looper thread is held with the clamp spring.

The wiper operates to hold the needle thread with the clamp spring.

And then, the presser foot is raised.

- (4) Release the pedal. (Fig. 1 ②)

The presser foot is lowered.

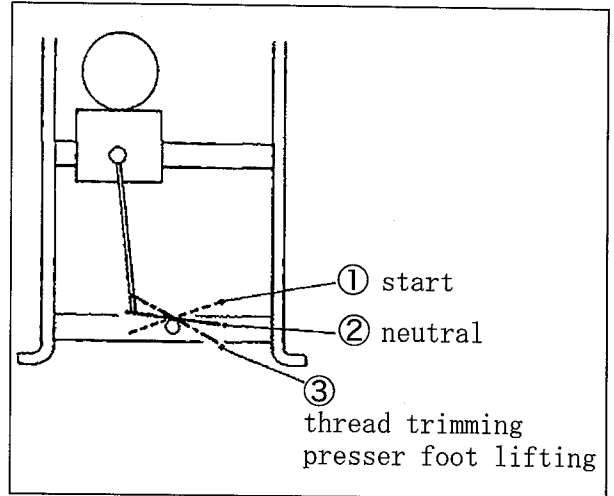

Fig. 1

NOTE

The presser foot can be moved up and down by heeling back the pedal to the positions ② and ③ until the pedal is toed down to the position ①.

1. Proper operation

⚠ CAUTION

Be sure to place a fabric under the presser foot when operating.

1.2 Operating procedure for UT-4/ST device

The motor can be selected 1 position or 2 position. The operating procedure for 1 position and 2 position is mentioned below.

- (1) Place a fabric under the presser foot and toe down the pedal. (Fig. 2 ①)

The machine starts sewing.

- (2) Release the pedal. (Fig. 2 ②)

The needle stops at the lowest point.

(Skip this procedure when 1 position is selected.)

- (3) Heel back the pedal. (Fig. 2 ③)

The needle rises and stops at the highest point.

The trimming knife mechanism operates to cut the needle and the looper threads under the stitch plate. The looper thread is held with the clamp spring.

ST2 device operates to cut and hold the top cover thread.

And then, the presser foot is raised.

- (4) Release the pedal. (Fig. 2 ②)

The presser foot is lowered.

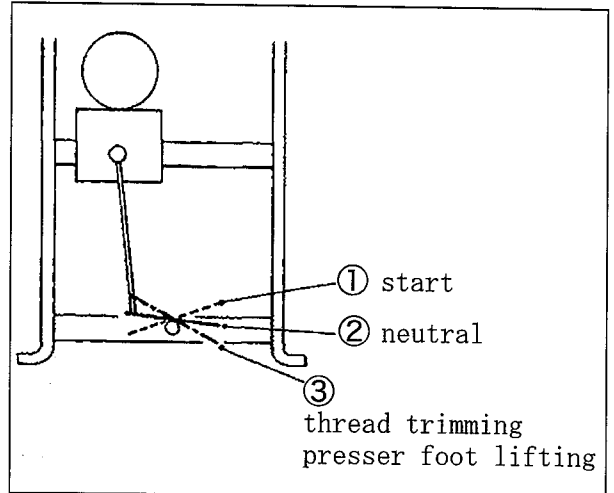

Fig. 2

NOTE

The presser foot can be moved up and down by heeling back the pedal to the positions ② and ③ until the pedal is toed down to the position ①.

2. Wiring

2.1 Detector switch

2.1.1 Adjusting detector switch

The detector switch works so that the machine does not run until the trimming knife returns to its original position.

- (1) Loosen the screws ① and ②.
- (2) Adjust the positions of the detector switch ③ and the switch guide ④ as below.
 - Make the switch turn ON when the trimming knife returns to its original position.
 - Make the switch turn OFF when the front of the upper knife touches the looper with moving the air cylinder by hand.
- (3) Tighten the screws ① and ② securely.

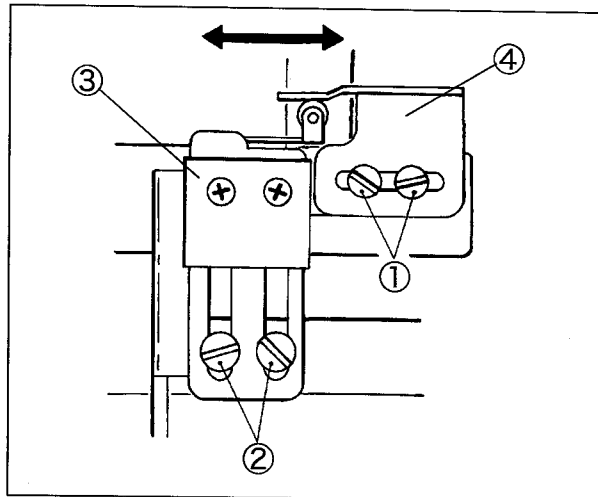

Fig. 3

2.1.2 Connecting detector switch

- (1) Connect the cords of the detector switch to the 3P-connector with the numbers as below.

black cord : ①
white cord : ③
red cord : ②

- (2) Connect the 3P-connector of the detector switch to that of the intermediate cable.

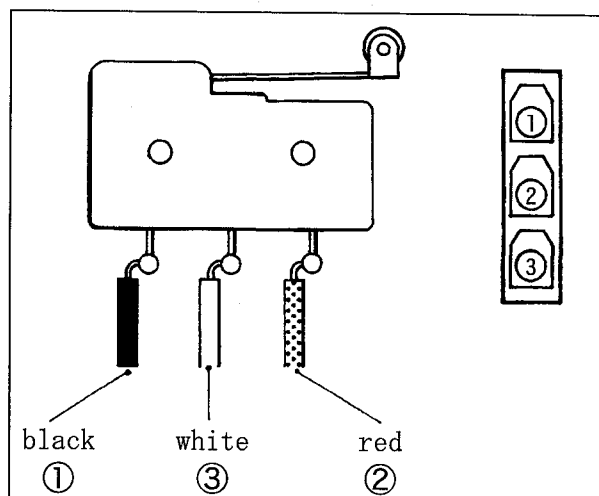

Fig. 4

2.2 Connecting solenoid

NOTE

Never short out black and red, or black and green.
If shorted, it can cause the damage to the internal circuit.

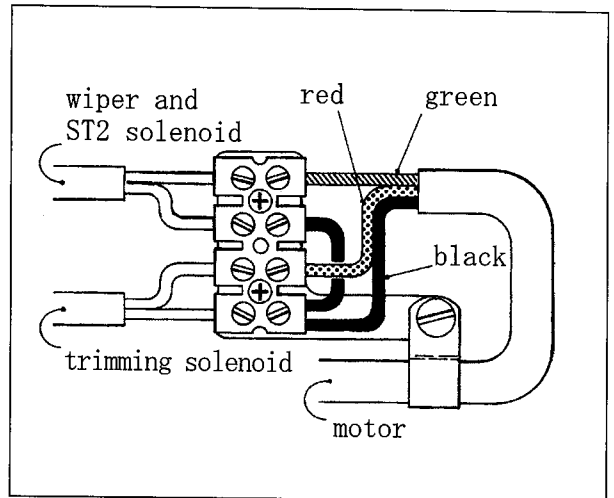

Fig. 5

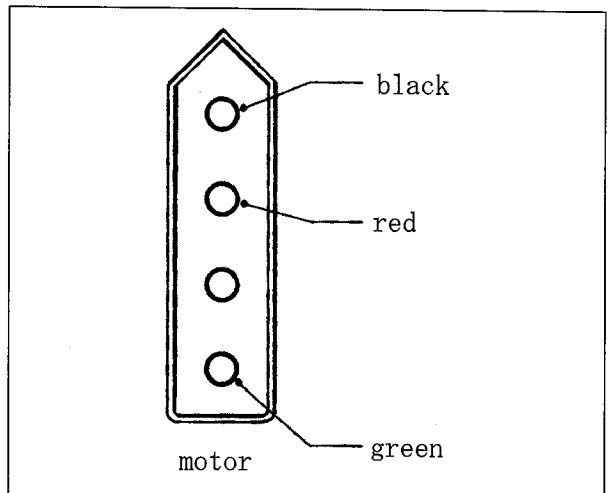

Fig. 6

3. Installing synchronizer

⚠ CAUTION

Unplug the solenoids for trimming and ST2 device from the control box for the motor.
If not, the parts may be touched and broken.

- (1) Install the synchronizer ① on the machine pulley and tighten the screws ② slightly.
- (2) Set the synchronizer positioning pin ③ into the groove of the synchronizer ① and tighten the screw ④ securely.
- (3) Turn the motor switch "ON".
- (4) Toe down the pedal to sew two or three stitches.
- (5) Heel back the pedal. Then the needle stops a certain position.
- (6) Loosen the screws ②. Rotate the pulley clockwise to align the line of the handwheel ⑤ with the dot ⑥ of the machine arm while keeping the positions of the screws ② (be sure not to rotate the shaft of the synchronizer).

NOTES

1. The needle bar is at the highest point at (6).
2. Use this device when the needle bar is at the position 0.5 mm below its highest point by further rotating the pulley.

- (7) Toe down the pedal to sew a few stitches. Check that the needle bar stops at the position 0.5 mm below its highest point.

After installing the synchronizer, plug the solenoids for trimming and ST2 device in the prescribed positions.

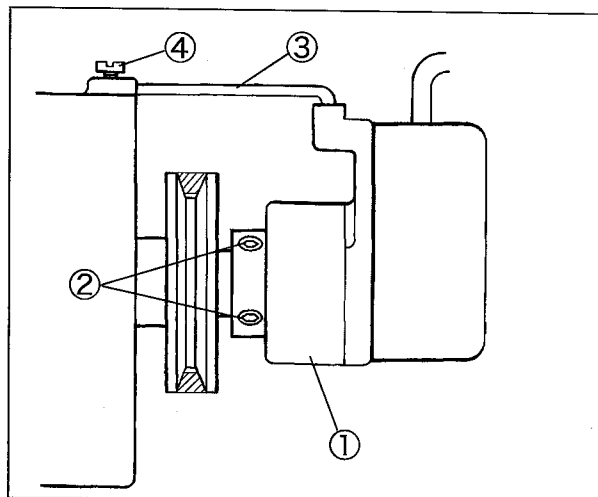

Fig. 7

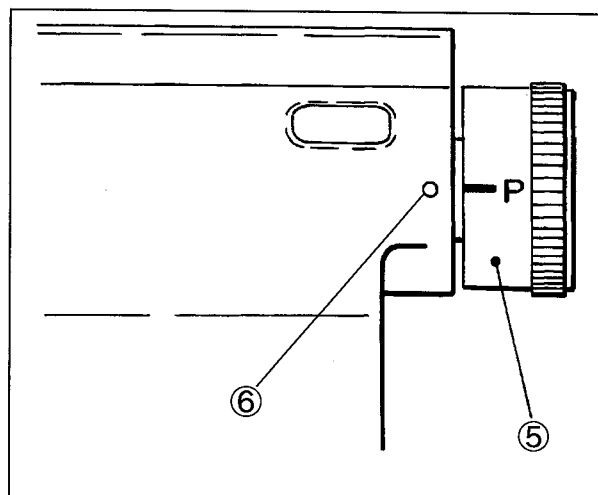

Fig. 8

4. Adjusting thread trimming mechanism

WARNING

ALWAYS turn the motor switch OFF and check that the motor has been already stopped.

4.1 Installing plunger rod

Set the plunger connecting rod ① and the plunger ② to the solenoid return shaft and the trimming solenoid shaft with the nuts ③ and ④ so that the solenoids shift smoothly right and left.

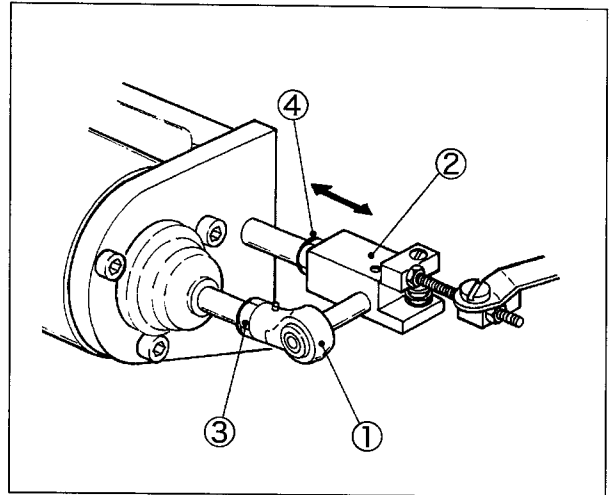

Fig. 9

4.2 Stroke of solenoid

The stroke of the solenoid is 15 mm.
Remove the solenoid dust-proof cover ⑤ and loosen the nuts ⑥ to adjust it.

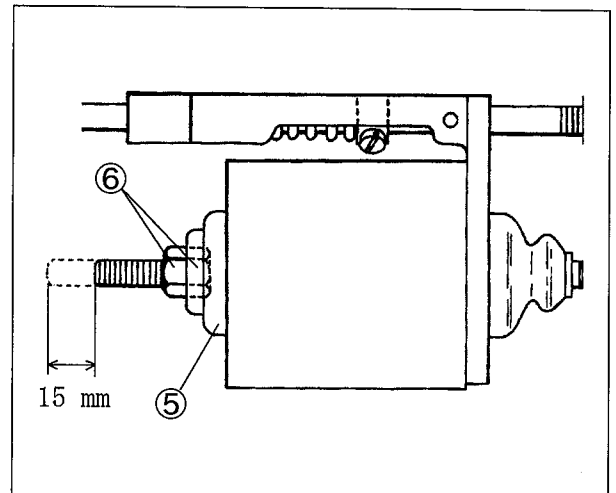

Fig. 10

CAUTION

Readjust the thread trimming mechanism after changing the stroke of the solenoid.

4.3 Solenoid return spring

The standard position of the collar ⑦ is 25 mm apart from the end of trimming solenoid support ⑧ when the plunger of the solenoid is at the left (the solenoid does not operate).

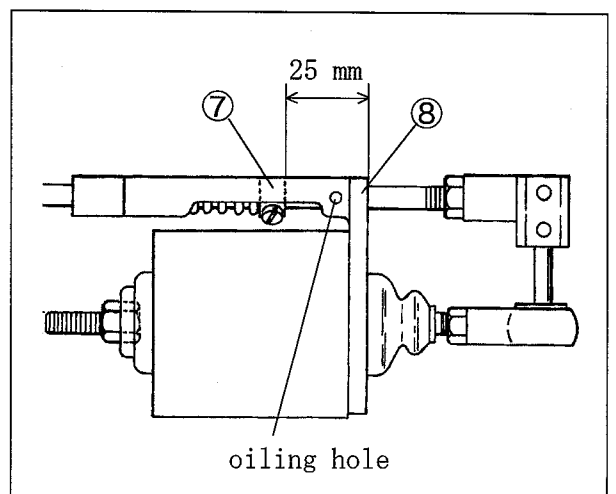

Fig. 11

CAUTION

Supply oil in the oiling hole (red) of the trimming solenoid support ⑧ once a week.

4.4 Position of lower knife

⚠ CAUTION

Operate the trimming knife mechanism manually only when the needle is at the highest point. If not, the parts may be touched and broken.

- (1) Set the part ② on the lower knife ① parallel to the part ④ on the lower knife carrier ③.
- (2) Tighten the screws ⑤ securely.

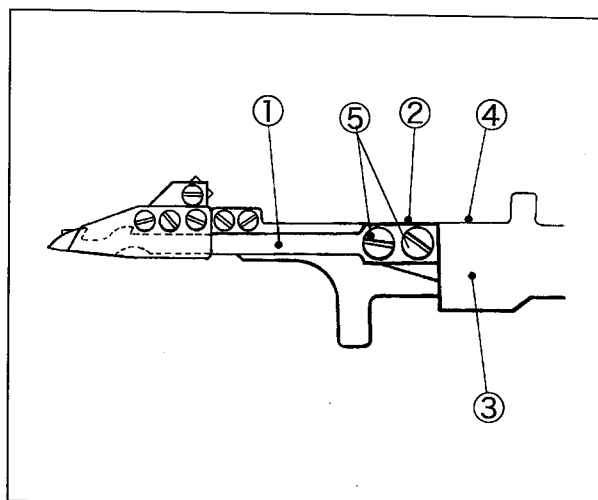

Fig. 12

4.5 Relation between upper and lower knives

- (1) Loosen the screws ⑩.
- (2) Adjust the needle thread hook ⑥ of the lower knife to pass at the corner ⑧ of the upper knife ⑦.
- (3) Move the upper knife ⑦ right or left to make the engagement between the looper thread hook ⑨ and the upper knife ⑦ to 0.5 mm when the lower knife is at the extreme right.
- (4) Tighten the screws ⑩ securely.

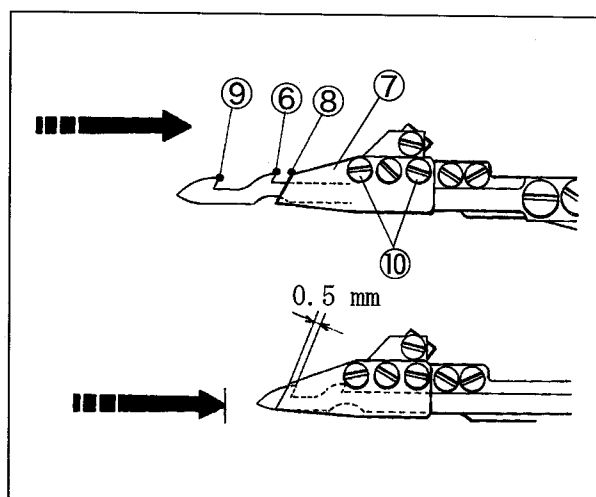

Fig. 13

4.6 Positions of clamp spring and clamp spring presser

- (1) Loosen the screws ②.
- (2) Set the part ④ of the lower knife ① even with the back of the clamp spring ③ when the lower knife moves to the right.
- (3) Tighten the screws ② securely.
- (4) Loosen the screws ⑥.
- (5) Set the back of the clamp spring pressure ⑤ even with the backs of the lower knife ① and the clamp spring ③.
- (6) Make the distance between the left tip of the clamp spring pressure ⑤ and the upper knife tip to 1 mm.
- (7) Tighten the screws ⑥ securely.

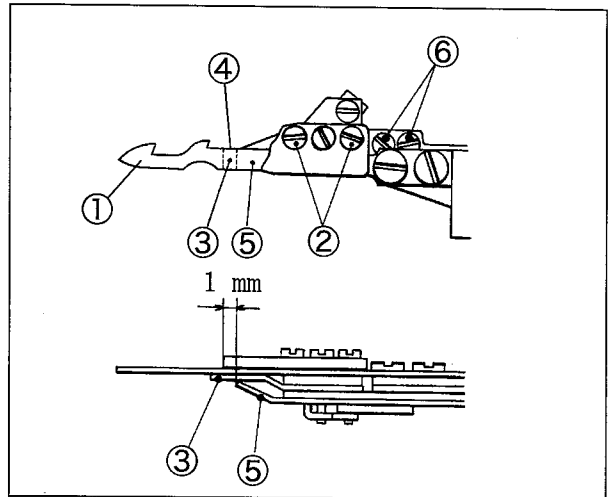

Fig. 14

4.7 Pressure of clamp spring

The looper thread is caught and held with the clamp spring ③ after cutting it.

Turn the adjusting screw ⑦ to adjust the pressure.

- To increase the pressure, turn it clockwise.
- To decrease the pressure, turn it counter-clockwise.

Keep the pressure to a minimum for holding the looper thread.

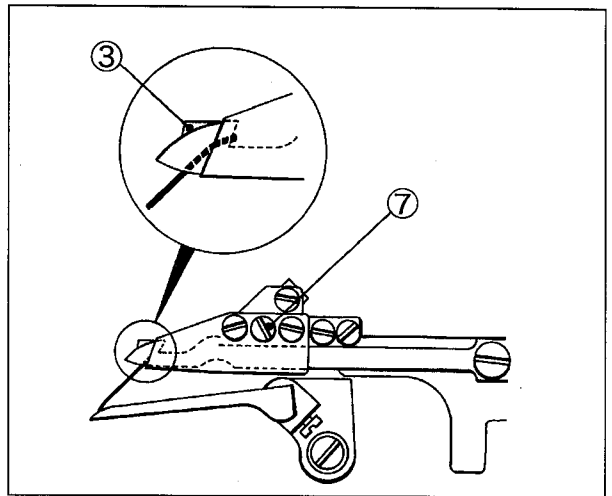

Fig. 15

4.8 Position of upper knife carrier

The upper knife carrier ⑨ slides to the left simultaneously with the lower knife carrier ⑧.

And it stops by touching the upper knife carrier stop ⑩.

The upper knife slides under the stitch plate.

The upper knife carrier stop positions with the screws ⑪ automatically.

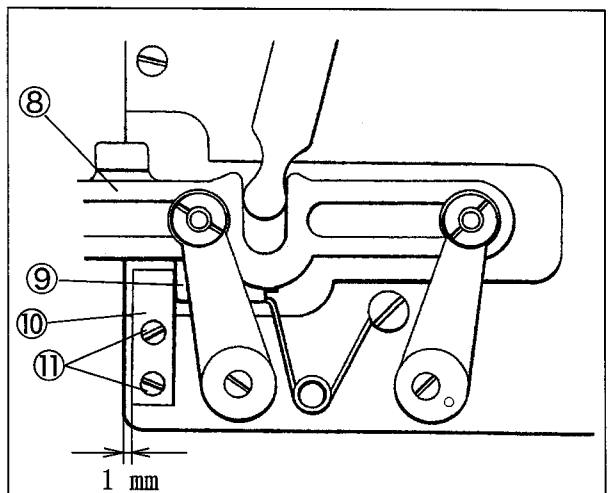

Fig. 16

4.9 Relation between lower knife and needle

- (1) Loosen the nuts ②.
- (2) Move the lower knife ① at the extreme left.
- (3) Move the connecting block ③ right or left to make the distance between the needle thread hook ④ and the left needle to 3.5 - 4.5 mm.
- (4) Tighten the nuts ② securely.

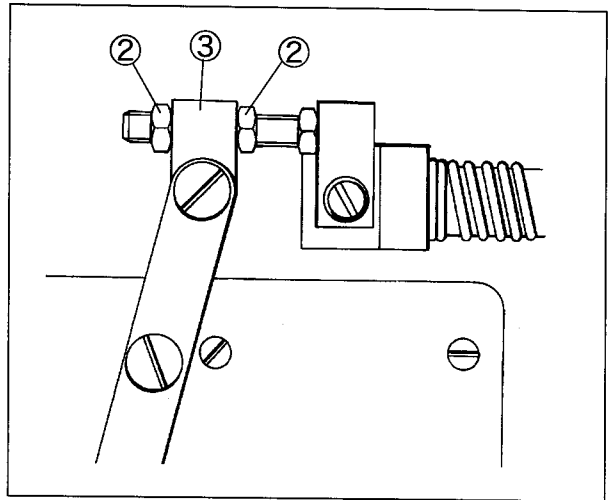

Fig. 17

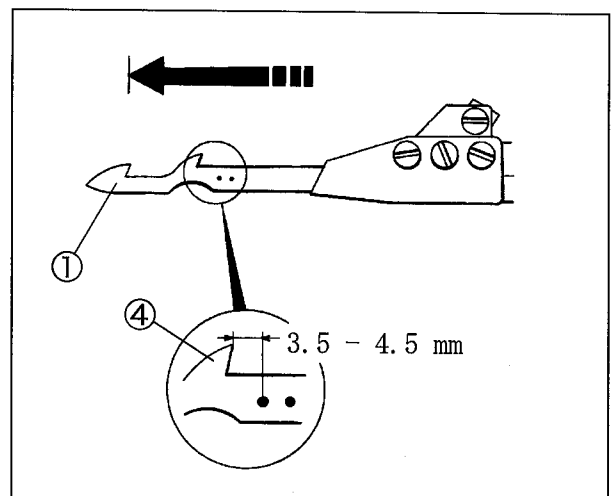

Fig. 18

4.Adjusting thread trimming mechanism

4.10 Position of lower kinfe tip

- (1) Move the lower knife① to the left.
- (2) When the distance between the tip② of the lower knife① and the right end of the looper is 12 mm, center the tip② with the flat part of the looper.
- (3) Loosen the screw③ and turn the knife guide lever ring(right)④ to adjust the tip②.
 - To move the tip backward, turn the ring④ clockwise.
 - To move the tip forward, turn the ring④ counterclockwise.
- (4) Tighten the screw③ securely.

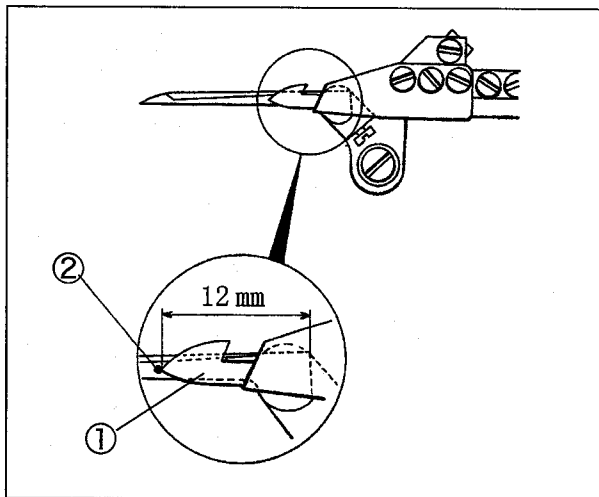

Fig. 19

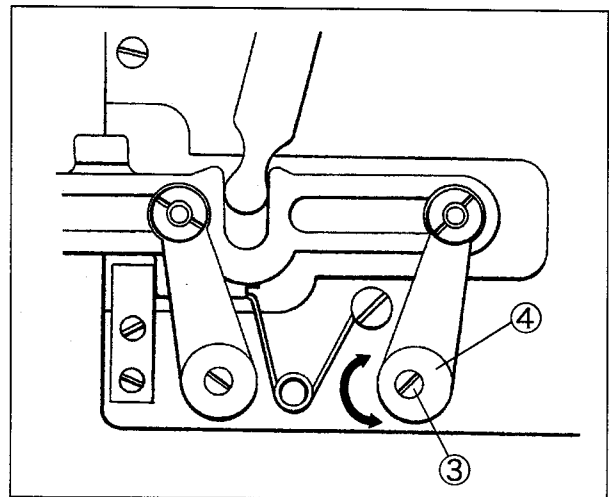

Fig. 20

4.11 Lower knife carrier guide

Make the clearance between the lower knife① and the upper end of the looper to 0.05 - 0.1 mm.

- (1) Loosen the screws②. Move the lower knife carrier guide③ up or down to adjust the clearance.
- (2) Tighten the screws② securely.
- (3) Check the upper and the lower knife carriers move smoothly.

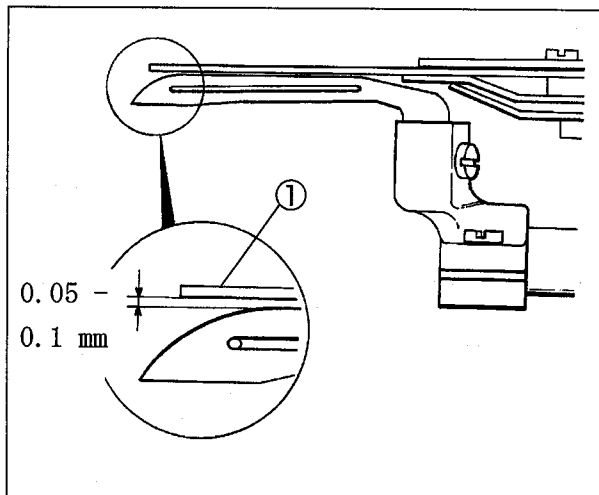

Fig. 21

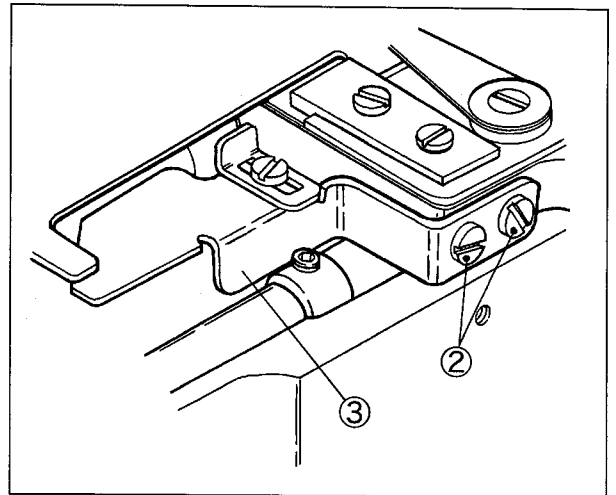

fig. 22

4.12 Lower knife carrier guide (upper)

The upper knife carrier slides to the left simultaneously with the lower knife carrier.

And it stops by touching the upper knife carrier stop.

- (1) Loosen the screw④.
- (2) Make the clearance between the lower knife carrier⑤ and the lower knife carrier guide (upper)⑥ to 0.05 - 0.1 mm when the upper knife carrier stops.
- (3) Tighten the screw④ securely.

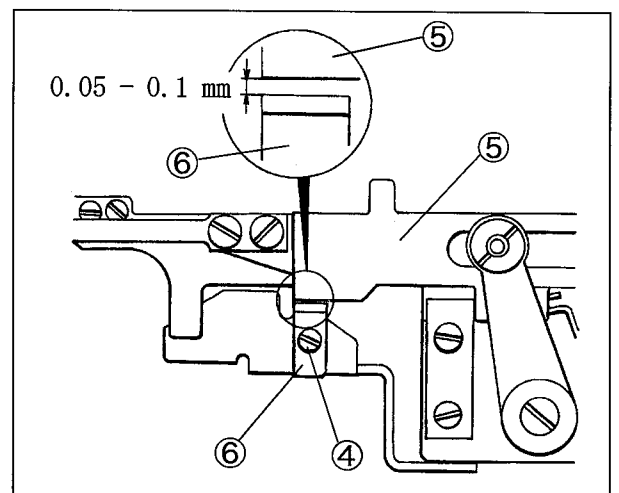

Fig. 23

4.Adjusting thread trimming mechanism

4.13 Relation between lower knife and needle thread or looper thread

After all adjustments, recheck following points before sewing.

★ The lower knife① should pass through the needle thread loops② and ③, and the hook④ should pass in front of the looper thread.

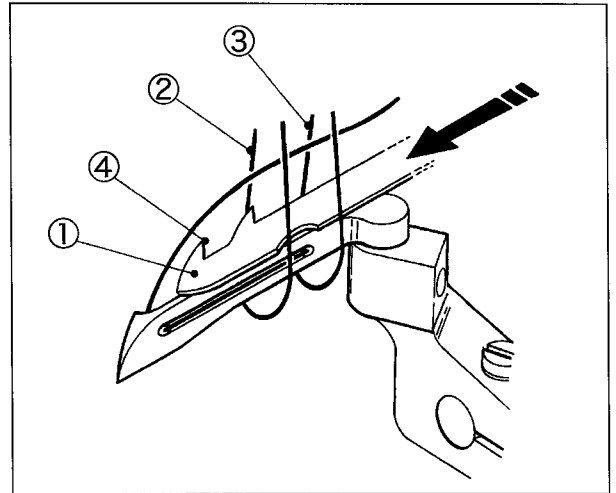

Fig. 24

★ The needle and the looper threads are pulled with the hooks④ and ⑤ to the right when the lower knife① returns. Then the upper knife cuts the threads.

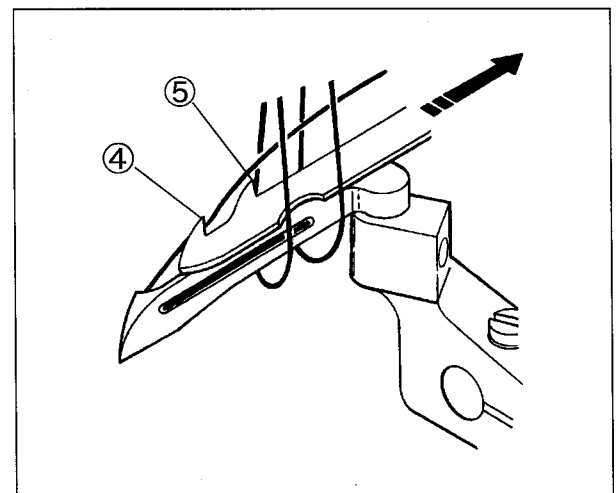

Fig. 25

5. Adjusting tension release mechanism

WARNING

ALWAYS turn the motor switch OFF and check that the motor has been already stopped.

5.1 Tension release block

- (1) Loosen the screw ③.
- (2) Make the clearance between the trimming solenoid support ① and the tension release block ② to 1 mm when the rod of the trimming solenoid is at the left (the trimming mechanism does not operate).
- (3) Tighten the screw ③ securely.

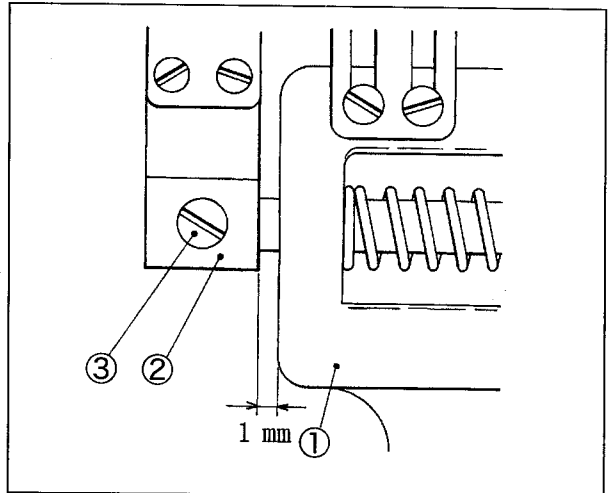

Fig. 26

5.2 Tension release connecting plate

Adjust it referring to Figs. 26 and 81.

- (1) Loosen the screw ③.
- (2) Adjust the position of the tension release block ② so that the tension release connecting plate ④ is in the center between the screw head ⑤ and the tension release lever ⑥.
- (3) Tighten the screw ③ securely.

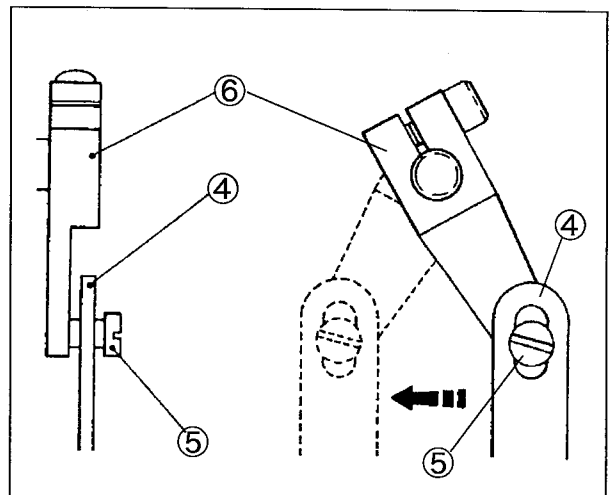

Fig. 27

5.3 Thread pull-off lever

- (1) Loosen the screw ⑧ of the tension release lever on the rear of the machine frame.
- (2) Raise the thread pull-off lever ⑦ at the highest point.
- (3) Tighten the screw ⑧ securely.

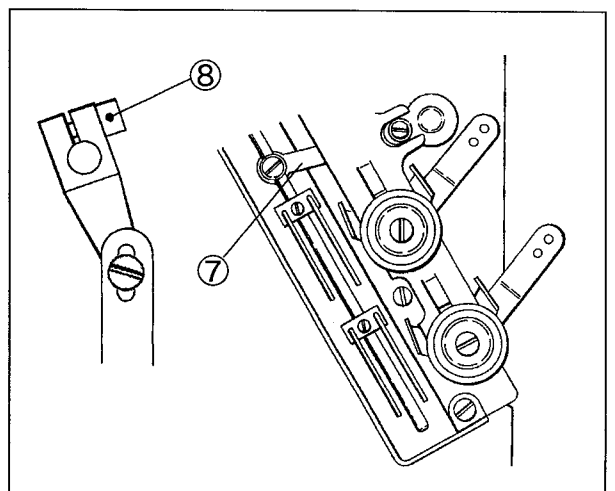

Fig. 28

5.Adjusting tension release mechanism

5.4 Looper thread pull-off (extra parts)

When using stretchable thread like woolly for the looper, use the looper thread pull-off③(No. 3100530) if required.

This is an extra part. Place an order from our agent or directly us.

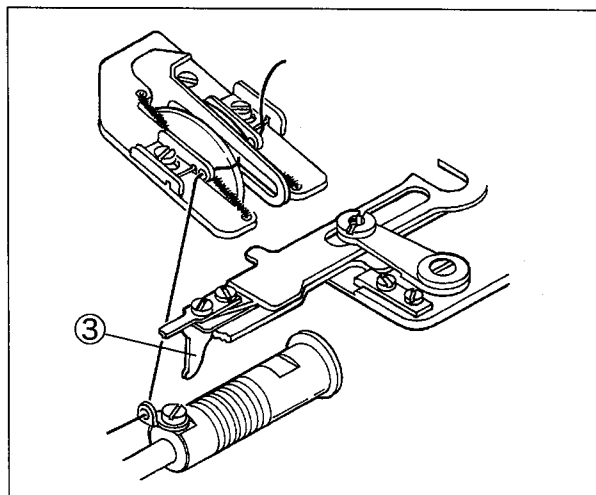

Fig. 29

5.5 Tension disc separator

- (1) Loosen the screw ② of the tension release adjusting eccentric ①.
- (2) Position the tension disc separator ③ by turning the tension release adjusting eccentric ① so that the thread tension discs can open as fast as possible.
To open it fast, lower the tension disc separator ③.
- (3) Loosen the screw ⑦ to set the top of the tension pull-off bar ④ 35 mm extruded from that of the thread pull-off eyelet ⑤.
- (4) Fix the tension pull-off bar ④ to the thread pull-off bar holder ⑥ with the screw ⑦.

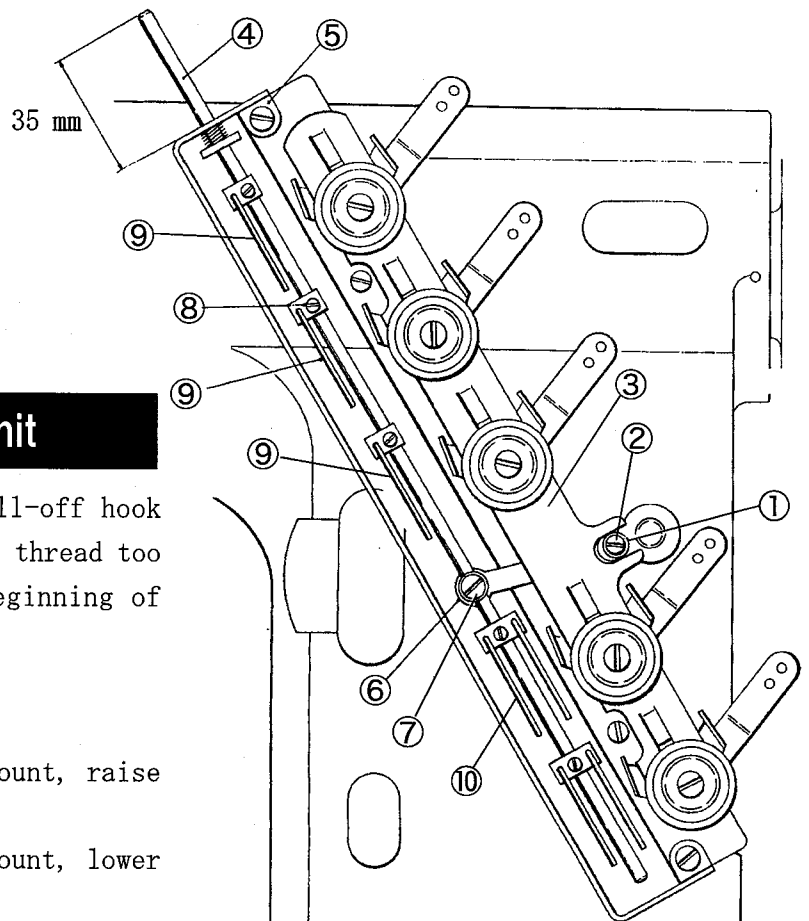

Fig. 30

5.6 Thread pull-off hook unit

Adjust the position of the thread pull-off hook unit ⑨ without remaining of the needle thread too much on the fabric surface at the beginning of sewing.

Loosen the screws ⑧ to adjust them.

- To decrease the thread pull-off amount, raise the thread pull-off hook unit ⑨.
- To increase the thread pull-off amount, lower the unit ⑨.

⚠ CAUTION

1. If the thread pull-off amount of the hook unit ⑨ is too little, the stitch cannot be formed at the beginning of sewing.
2. Use the thread pull-off hook unit ⑩ only when using woolly thread for the looper. When not using, raise it at the position the thread does not pull-off.

6. Adjusting wiper

WARNING

ALWAYS turn the motor switch OFF and check that the motor has been already stopped.

6.1 Wiper and needles

The shaft of the solenoid is out 0.9 mm forward while turning when the solenoid operates.

Turn the solenoid lever ⑨ downward while pulling toward the operator to adjust it.

- (1) Raise the needles at the heighest points.
- (2) Loosen the screw ③ so that the hook ② of the wiper ① passes 2.5 - 3.0 mm from front of the center of the needle. (Figs. 31 and 32)
- (3) Loosen the screw ④ to pass the wiper ① 1.0 mm below the left needle. (Figs. 31 and 32)

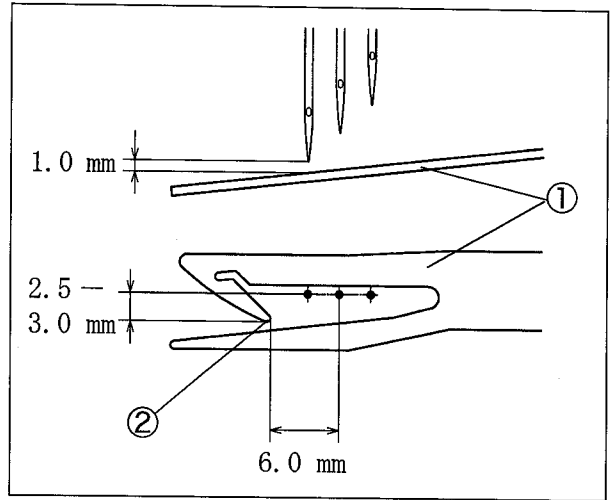

Fig. 31

6.2 Distance of wiper

Adjust the distance from the center of the needle bar to the hook ② to 6.0 mm when the wiper ① is at the extreme left.

Loosen the screw ⑤ of the wiper holder to adjust it. (Figs. 31 and 32)

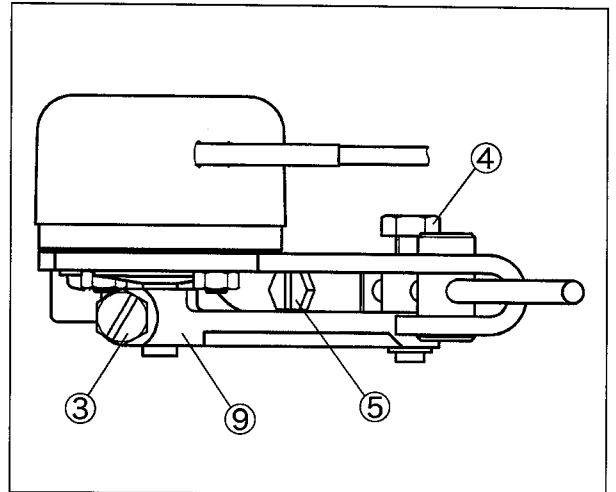

Fig. 32

6.3 Wiper and thread clamp rubber

Loosen the screw ⑦ to hold the needle thread slightly with the thread clamp rubber ⑥ and the wiper ① when the wiper ① returns. (Fig. 33)

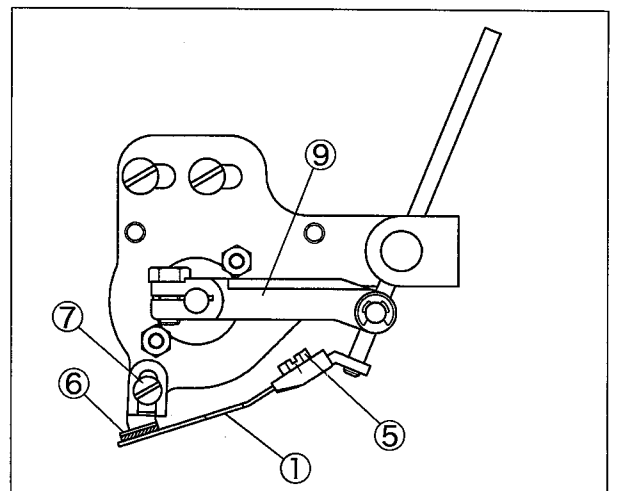

Fig. 33

6.4 Standard position of solenoid support

Make the clearance between the machine arm and the solenoid support ① to 3 mm.

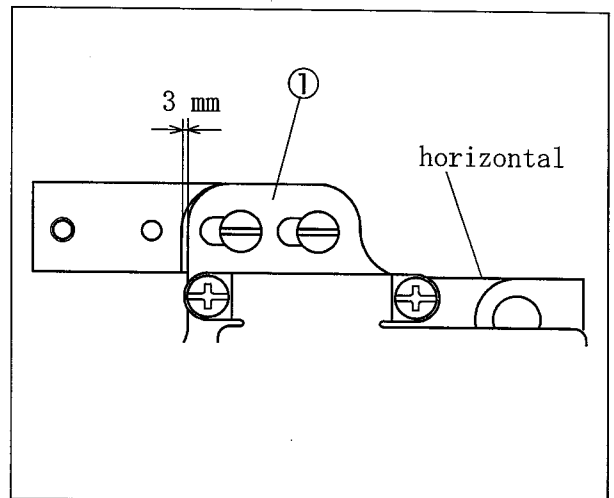

Fig. 34

6.5 Standard position of solenoid lever

Make the clearance between the solenoid support ① and the solenoid lever ② to 2.5 mm. Also set the solenoid lever ② horizontally when it returns.

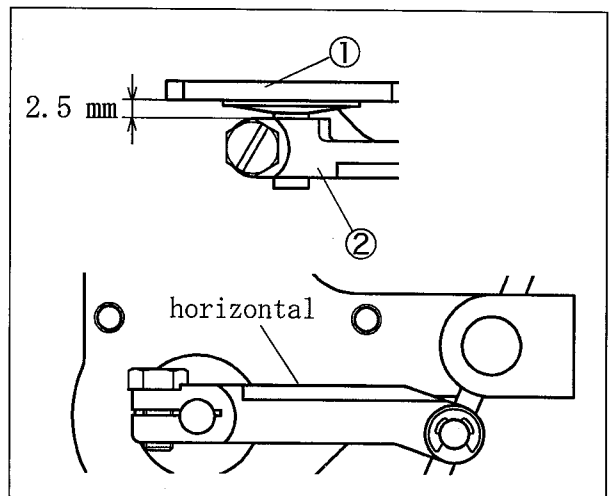

Fig. 35

6.6 Standard position of wiper

Make the distance between the wiper holder ③ and the end of the wiper ④.

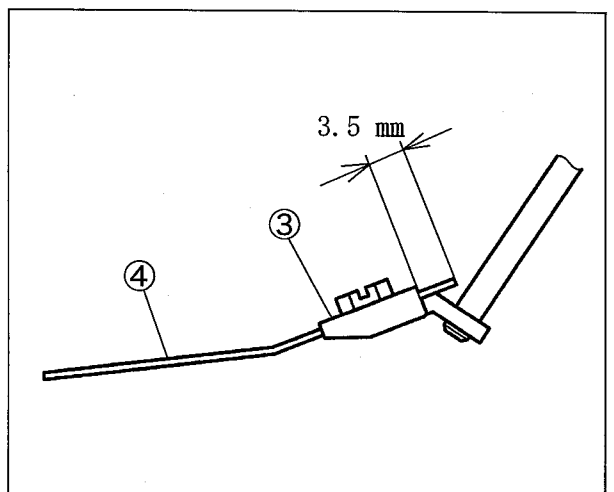

Fig. 36

7. Presser foot lifter mechanism

WARNING

ALWAYS turn the motor switch OFF and check that the motor has been already stopped.

- (1) Fix the plunger ② with the nut ①.
- (2) Adjust the presser foot to raise by 7 mm with the chain ③ when the plunger ② moves in the direction X (the solenoid operates).
- (3) Adjust the chain with slack slightly when the plunger ② moves in the direction Y.

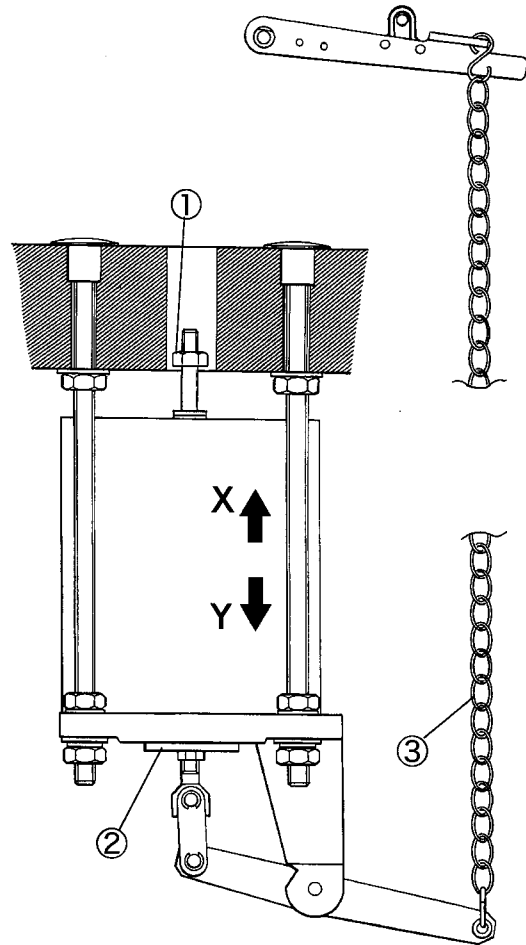

Fig. 37

8.ST2 device

⚠ WARNING

ALWAYS turn the motor switch OFF and check that the motor has been already stopped.

8.1 Position of movable trimming knife

- (1) Align the line of the handwheel ① with the mark ② of the machine arm (the needle is at the highest point).
- (2) Insert a pair of tweezers through the hole ④ to set the movable trimming knife ③ at the lowest point.

⚠ CAUTION

Never touch the movable trimming knife ③ to the presser foot, the left needle ⑤, and the spreader ⑥ when lowering. If touched them, loosen the screws ⑦ and ⑧ to adjust it.

- (3) Loosen the screws ⑧ to cross the movable trimming knife ③ tip over the top cover thread when the movable trimming knife ③ is at the lowest point.

NOTE

Adjust the tip ⑨ of the movable trimming knife ③ 5.5 - 6.0 mm above the top of the stitch plate as standard.

- (4) After that, tighten the screws ⑦, ⑧, and ⑩ securely.
- (5) Check the position of the movable trimming knife ③ while moving it up and down.

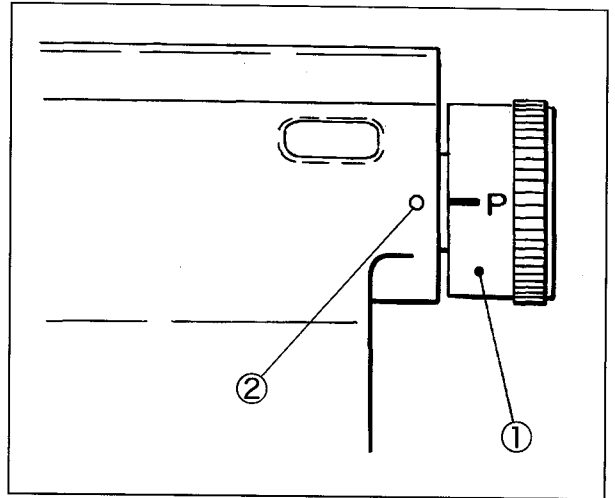

Fig. 38

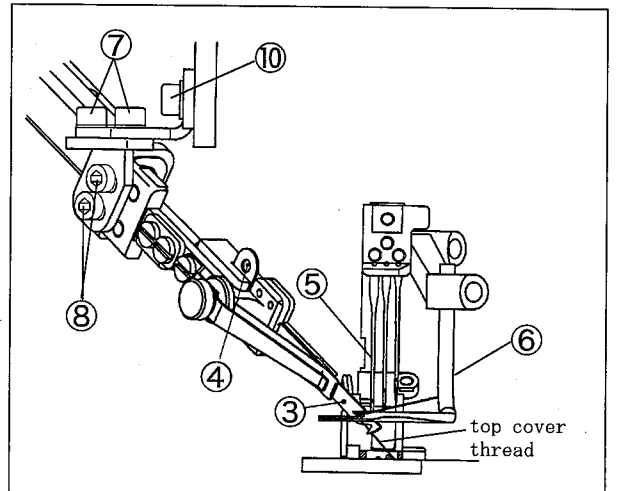

Fig. 39

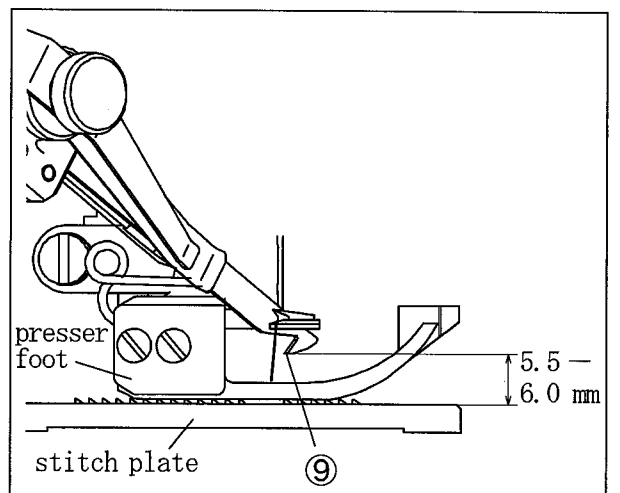

Fig. 40

8.2 Engagement between movable and fixed trimming knives

The engagement between the movable trimming knife ① and the fixed trimming knife ② is set to 0 - 0.5 mm in Fig. 41 at shipment.

- (1) Loosen the screw ③ of the solenoid lever ④.
- (2) Engage the fixed trimming knife ② with the movable trimming knife ① to 0 - 0.5 mm when the knife ① is inmost.
- (3) Tighten the screw ③ securely.

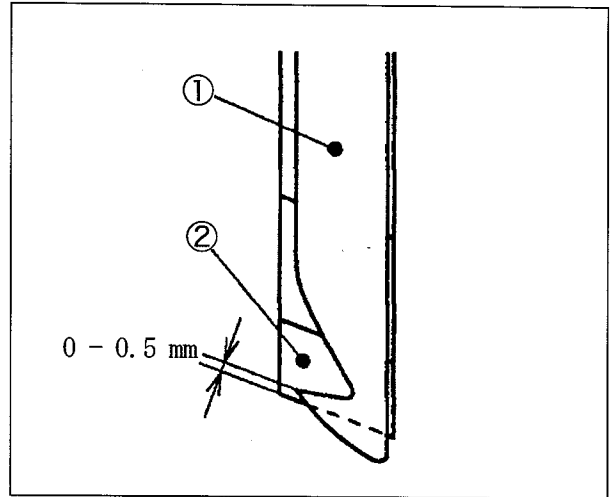

Fig. 41

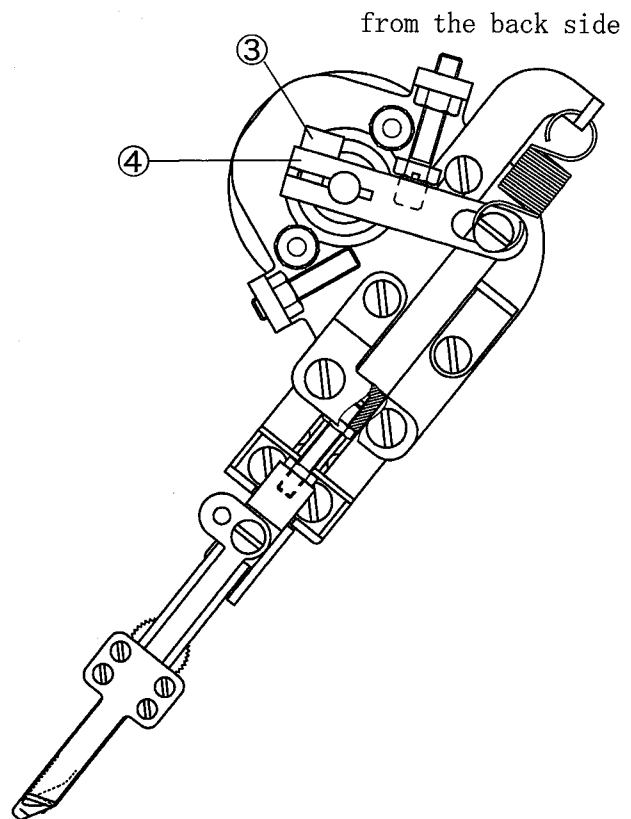

Fig. 42

8.3 Adjusting stroke of movable trimming knife

The stroke from the tip② of the movable trimming knife① to the fixed trimming knife③ is set to 19.5 mm at shipment.

- (1) Loosen the nut④.
- (2) Apply the adjusting screw⑥ tip to the solenoid lever⑤ when the stroke is 19.5 mm and the movable trimming knife① is out fully.
- (3) Tighten the nut④ securely.

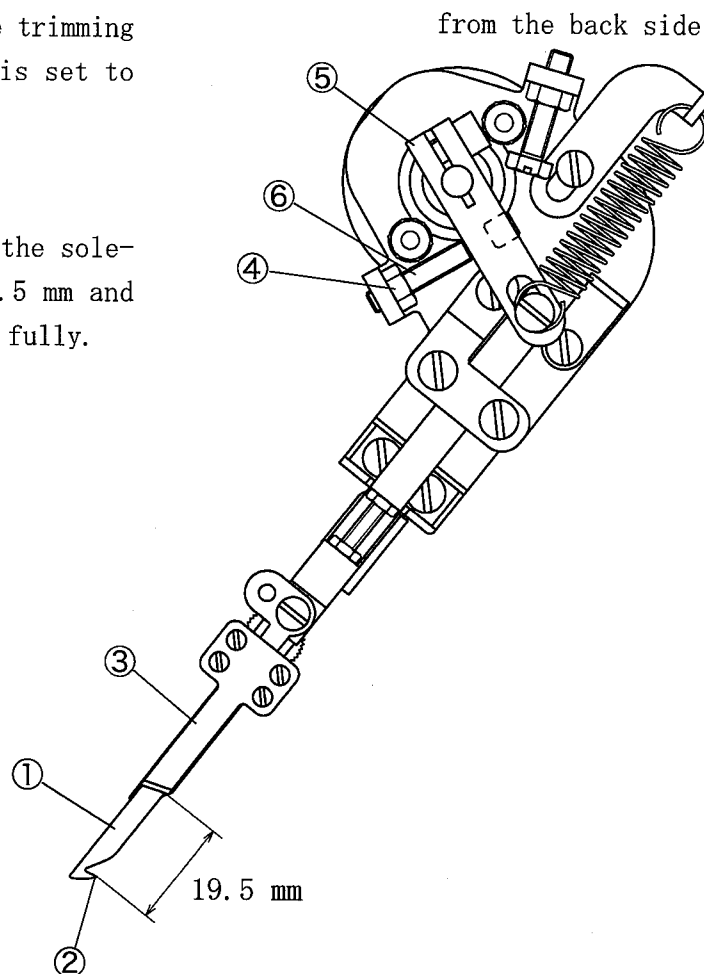

Fig. 43

8.4 Pressure of thread clamp spring

Keep the pressure to a minimum for holding the threads.

- (1) Loosen the nut⑦.
- (2) Adjust the pressure with the adjusting screw⑨ so that the thread clamp spring⑧ and the movable trimming knife① hold the threads cut with the knives.

To increase the pressure, tighten the adjusting screw⑨.

- (3) Tighten the nut⑦ securely.

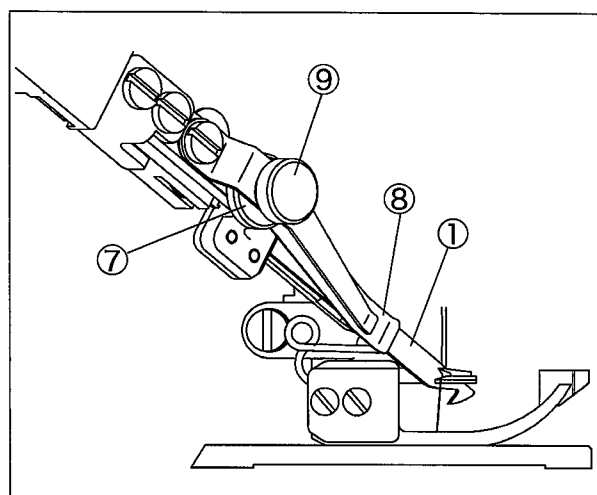

Fig. 44

8.5 Adjusting spring

Loosen the screw① and move the spring hanger② to adjust it.

- To increase the spring pressure, move it upward.
- To decrease the spring pressure, move it downward.

Keep the pressure to a minimum within the range that the movable trimming knife can return.

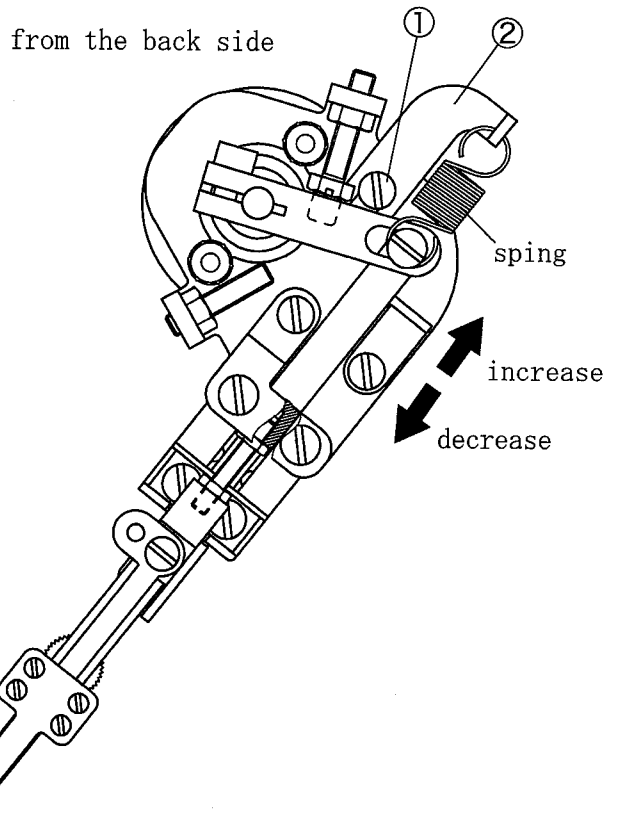

Fig. 45

8.6 Adjusting thread pull-off hook unit

- To decrease the thread pull-off amount, raise the thread pull-off hook unit③.
- To increase the thread pull-off amount, lower it③.

NOTES

1. The feed of the thread should be as much as possible. If not enough, the top cover thread cannot be held after cutting.
2. When using stretchable thread like woolly, thread through the top cover thread eyelet④.

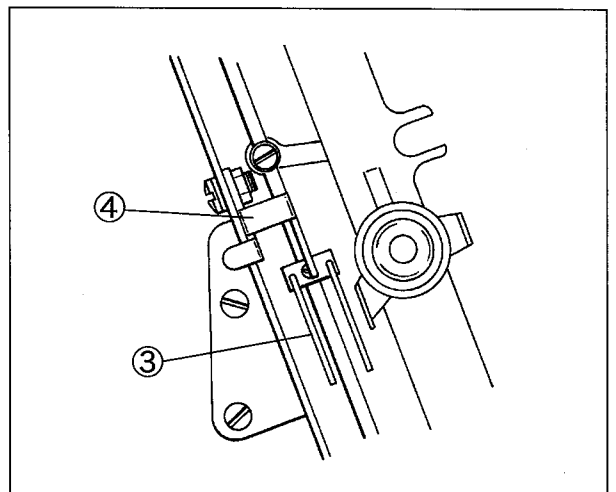

Fig. 46

Yamato

ヤマトマシン製造株式会社

YAMATO SEWING MACHINE MFG. CO., LTD.

4-4-12,NISHITENMA, KITA-KU, OSAKA,JAPAN
TEL : 81-6-6364-1321 FAX : 81-6-6364-1307

〒530-0047 大阪市北区西天満4丁目4番12号
TEL(06)6364-1321(代) FAX(06)6365-5176