



---

## Product Support Manual

# **EPIRB** **Emergency Position Indicating Radio Beacon** **RLB-36**

Y1-03-0233 Rev. T2

### **ACR Electronics, Inc.**

5757 Ravenswood Road  
Fort Lauderdale, FL 33312

Tel : +1(954) 981-3333

Fax: +1 (954) 983-5087

[www.acrelectronics.com](http://www.acrelectronics.com)

Email: [info@acrelectronics.com](mailto:info@acrelectronics.com)

**\* \* \* WARNING \* \* \***

**THIS TRANSMITTER IS AUTHORIZED FOR USE  
ONLY DURING SITUATIONS OF GRAVE  
AND IMMINENT DANGER  
DELIBERATE MISUSE MAY INCUR A SEVERE PENALTY**



**Magnet Safe Distance  
1m (3.3 ft)**

Keep this beacon a safe distance  
away from all magnetic sources



**Stereo Speaker Safe Distance  
1m (3.3 ft)**

Keep this beacon a safe distance away  
from all stereo speakers



**IF YOU HAVE ANY TROUBLE WITH  
YOUR NEW 406 BEACON, DO NOT RETURN  
IT TO THE STORE!  
CALL ACR ELECTRONICS AT  
+1 (800) 432-0227. WE WILL HELP YOU  
RESOLVE ANY PROBLEMS YOU MAY BE  
EXPERIENCING. MANY QUESTIONS CAN BE  
ANSWERED OVER THE PHONE.**

**LIMITED WARRANTY**

This product is warranted against factory defect in material and workmanship for a period of five years from date of purchase or receipt as a gift. During the warranty period ACR Electronics, Inc. will repair or, at its option, replace at no cost to you for labor, materials or return transportation, provided you obtain a Return Authorization from ACR Electronics, Inc., 5757 Ravenswood Road, Ft. Lauderdale, Fl. 33312-6645. To obtain a Return Authorization, call our Customer Service Department at (800) 432-0227. This warranty does not apply if the product has been damaged by accident or misuse, or as a result of service or modification by other than the factory. Except as otherwise expressly stated, the COMPANY MAKES NO REPRESENTATION OR WARRANTY OF ANY KIND, EXPRESS OR IMPLIED, AS TO MERCHANTABILITY, FITNESS FOR A PARTICULAR PURPOSE, OR ANY OTHER MATTER WITH RESPECT TO THIS PRODUCT. The Company shall not be liable for, consequential or special damages.

In order to place the warranty in effect, the accompanying registration card must be returned to us within ten days of purchase.

## TABLE OF CONTENTS

<b>SECTION 1 – FOREWORD AND PRODUCT FEATURES</b>	<b>4</b>
<b>SECTION 2 – REGISTRATION OF 406 MHZ BEACONS</b>	<b>5</b>
2.1 Registration importance	5
2.2 Where to register	5
2.3 Registration in the United States	5
2.4 Leisure vessels in the United States	6
2.5 Commercial vessels in the United States	6
2.6 Do I need a radio station license?	6
2.7 Commercial vessels world wide	6
2.8 Registration outside the United States	6
2.9 Change of ownership or contact information	6
2.10 Lost or stolen EPIRBs	7
<b>SECTION 3 – FALSE ALARMS</b>	<b>7</b>
3.1 Prevention of false alarms	7
3.2 Reporting of false alarms	7
<b>SECTION 4 – INSTALLATION</b>	<b>8</b>
4.1 Mounting location	8
4.2 Visual inspection	8
4.3 Hydrostatic release unit (HRU) category 1 beacon	8
<b>SECTION 5 – ACTIVATION AND DEPLOYMENT</b>	<b>9</b>
5.1 Bracket configuration	9
5.2 Category 1 & 2 bracket dimensions	10
5.3 Configuration overview	11
5.4 Automatic deployment and activation - Category I Beacons	12
5.5 Manual deployment and activation	12
5.6 Manual activation without deployment	13
5.7 Deactivation	13
<b>SECTION - 6 INTERNAL AND EXTERNAL GPS</b>	<b>13</b>
6.1 Self testing the beacon	13
6.2 GPS acquisition with the external GPS	14
6.3 Using the external GPS interface	14
6.4 Testing the external GPS interface	14
6.5 Updating the external GPS position data	14
6.6 Internal GPS navigation system	15
6.7 Internal GPS Testing	15
6.8 LED indication of GPS fix	16
6.9 OLED display	16
<b>SECTION 7 – CARE AND MAINTENANCE</b>	<b>16</b>
7.1 Routine maintenance	16
7.2 Battery replacement	16
7.3 Shore based maintenance for SOLAS Vessels	17
7.4 Annual testing for SOLAS vessels, IMO MSC/Circ. 1040	17
<b>SECTION 8 – THE SEARCH AND RESCUE SYSTEM</b>	<b>17</b>
8.1 General overview	17
8.2 Satellite detection	17
8.3 Global Positioning System (GPS)	18
<b>SECTION 9 – TECHNICAL INFORMATION</b>	<b>19</b>
9.1 Type approvals and standards	19
9.2 Specifications	19
9.3 Support	21
9.4 Beacon Images	21

# SECTION 1 – FOREWORD AND PRODUCT FEATURES

Thank you for purchasing from ACR Electronics, Inc. We design, manufacture and distribute quality products knowing they are used to save lives. Many of our products are required to be tested and approved by regulatory bodies worldwide. We believe in going beyond those specifications to insure our products work when needed in real world conditions. With proper care and maintenance your ACR product will last for years. It is important that you thoroughly read this product support manual to understand the proper care and use of your ACR product.

ACR is proud to be certified to ISO 9001: 2000, the International Standard for Quality.

This manual provides installation, operation and maintenance instructions for the RLB-36 EPIRB, hereinafter referred to as the beacon. This manual also describes the characteristics and details of the beacon system. In the USA, the FCC authorizes the use of 406 MHz Radio beacon by any ship that is also equipped with a VHF ship station. This will make the 406 MHz radio beacon available for use on most U.S. ships and boats. Commercial EPIRB carriage requirements are contained in IMO and/or USCG regulations.

Product	Model Number	Product Number	Category	Class	GPS Interface
GlobalFix™ iPro	RLB-36	xxxx	1	2	Internal and external
GlobalFix™ iPro	RLB-36	xxxx	2	2	Internal and external

## Product Features

1. Sturdy antenna
2. Ultrabright strobe can be seen for over 2 miles
3. Secondary graphical OLED display unit
4. Reflective tape exceeds RTCM specifications
5. Highly visible ACR-truse™ case is durable and withstands the harshest of environments
6. Grips provide ease when holding the beacon while wet.

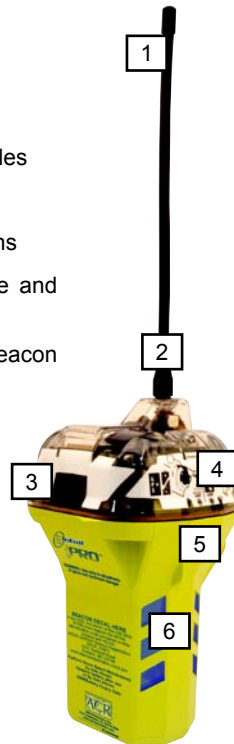

Product Features

Figure 1

# SECTION 2 – REGISTRATION OF 406 MHZ BEACONS

## 2.1 Registration importance

It is mandatory that the owner of this 406 MHz beacon register it with the national authority.\* All 406 MHz beacons transmit a Unique Identifier Number (UIN) when activated. This UIN is programmed in the beacon based on the country in which the beacon was purchased. Registration provides the Search and Rescue (SAR) forces with up to date emergency contact information, which will speed up the launch of a rescue operation. The national authorities

**NOAA SARSAT Beacon Registration**  
**NSOF, E/SP3**  
**4231 Suitland Road**  
**Suitland, MD 20746**

**For Faster Service, Register Online!**  
**In the United States:**  
**[www.beaconregistration.noaa.gov](http://www.beaconregistration.noaa.gov)**

use the information to verify if an actual emergency exists. Valuable search and rescue resources are wasted every year responding to false alarms. SAR forces will know who you are, what type of vessel you have, your homeport, and who to contact that might know of your current situation ONLY if your beacon has been properly registered. This will help expedite the launch of a rescue operation. All 406 MHz beacons are required to have their registration updated every two years.

\*The national authority is the governmental body responsible for EPIRB registration database administration for the country for which the EPIRB is programmed.

## 2.2 Where to register

The owner of a 406 MHz beacon (EPIRB) should register it with the national authority for which the beacon was programmed (typically the country where purchased), regardless of where they do their boating. However, the beacon must be reprogrammed if the boat or its owner moves or sails under a different national authority than the one for which the beacon was previously programmed. Each beacon is programmed with a Unique Identification Number (UIN) for the country that the unit is shipped to, and will only be accepted for registration in that country. To verify the country for which a beacon is programmed, see the label with the UIN on the side of the unit. Units that do not have a country specified on the UIN label are programmed for the United States.

## 2.3 Registration in the United States

It is the owner's responsibility to register 406 MHz beacons that are programmed for and purchased in the United States. The national authority that accepts registrations in the United States is the National Oceanic and Atmospheric Administration (NOAA). The fastest and easiest way to register your beacon with NOAA is to use the online registration database at [www.beaconregistration.noaa.gov](http://www.beaconregistration.noaa.gov). If internet is not accessible then the owner should complete the enclosed registration form (Do not confuse this with the ACR Electronics warranty card) and mail with the pre-addressed, postage paid envelope to:

The information provided on the registration form is used only for rescue purposes. Complete and send the registration immediately! Registration can be expedited by registering online or by faxing the registration form to Fax # (301) 817-4565. If the beacon is going to be placed into immediate service, register online or by fax.

All registration forms will be entered in the 406 MHz beacon registration database within 48 hours of receipt. A confirmation letter, a copy of the actual registration and a proof-of-registration decal will be mailed to you within two weeks. When you receive these documents, please check the information carefully and affix the decal to your beacon in the area marked "BEACON DECAL HERE." If you do not receive confirmation back from NOAA, call toll free 1-888-212-7283 for assistance.

## **2.4 Leisure vessels in the United States**

In the United States, leisure vessels are sometimes required to have a radio station license. Leisure vessels that are required to have a radio station license are required to modify that license when an EPIRB is added to the vessel. For information on whether you need a radio station license, see section 2.6 (below).

## **2.5 Commercial vessels in the United States**

In the United States, commercial vessels that are required to have a radio station license are required to modify that license when an EPIRB is added to the vessel. For information on whether you need a radio station license, see section 2.6 (below).

## **2.6 Do I need a radio station license?**

The information in this section is provided for informational purposes only. Always check the FCC's website at [http://wireless.fcc.gov/services/index.htm?job=licensing&id=ship\\_stations](http://wireless.fcc.gov/services/index.htm?job=licensing&id=ship_stations) or call toll-free 1-888-CALLFCC (225-5322) for the latest information.

You do not need a license to operate a marine VHF radio, radar, or EPIRBs aboard voluntary ships operating domestically. The term "voluntary ships" refers to ships that are not required by law to carry a radio. Generally, this term applies to recreation or pleasure craft. The term "voluntary ships" does not apply to the following:

1. Cargo ships over 300 gross tons navigating in the open sea;
2. Ships certified by the U.S. Coast Guard to carry more than 6 passengers for hire in the open sea or tidewaters of the U.S.;
3. Power driven ships over 20 meters in length on navigable waterways;
4. Ships of more than 100 gross tons certified by the U.S. Coast Guard to carry at least one passenger on navigable waterways;
5. Tow boats of more than 7.8 meters in length on navigable waterways; and,
6. Uninspected commercial fishing industry vessels required to carry a VHF radio.
7. Ships required to carry an Automatic Identification System (AIS) transceiver by the U.S. Coast Guard regulations enacted pursuant to the Maritime Transportation Security Act of 2000.

Ships are considered as operating domestically when they do not travel to foreign ports or do not transmit radio communications to foreign stations. Sailing in international waters is permitted, so long as the previous conditions are met. If you travel to a foreign port (e.g., Canada, Mexico, Bahamas, British Virgin Islands), a license is required. Additionally, if you travel to a foreign port, you are required to have an operator permit.

## **2.7 Commercial vessels world wide**

406 MHz beacons that are carried on commercial vessels world wide should be registered with the country where the vessel is flagged regardless of where the vessel operates. When a commercial vessel acquires a 406 MHz beacon from outside of its home country, the beacon should be reprogrammed for the home country and registered there.

## **2.8 Registration outside the United States**

In countries other than the United States, 406 MHz beacons are registered with that country's national authority at the time of purchase. The sales agent should assist in filling out the forms and sending to that country's national authority. To verify that the unit is properly programmed for that country, view the UIN label on the side of the unit. In the event that the beacon is not programmed for the country it has been purchased in, the sales agent, (if properly equipped) can reprogram the unit for that country.

## **2.9 Change of ownership or contact information**

It is the owner's responsibility to advise the national authority of any change in the information on the registration form. If the current owner of the beacon is transferring the beacon to a new owner, the current owner is required to inform the national authority by using their online database or by letter, fax or telephone, of the name and address of the new

owner. The new owner of the beacon is required to provide the national authority with all of the information requested on the registration form. This obligation transfers to all subsequent owners. Registration forms for the United States are available from NOAA by calling 1 (888) 212-7283 or by visiting the ACR website at [www.acelectronics.com](http://www.acelectronics.com).

## 2.10 Lost or stolen EPIRBs

Inform NOAA immediately at 1-888-212-SAVE (7283), or your national authority, if your EPIRB has been lost or stolen. They will update your EPIRB registration information with the appropriate information.

Stolen EPIRBs - Things That You Need To Do:

- Report to your local authorities that the EPIRB has been stolen.
- Contact NOAA at 1-888-212-SAVE (7283), or your national authority, with the following information so your EPIRB registration information can be updated with the appropriate remarks: Police Department Name, Phone Number, and Case Number

If your EPIRB were to be activated, the information you provided will be forwarded to the appropriate search and rescue authorities who will ensure that your EPIRB gets back to you. If someone attempts to register an EPIRB reported as stolen, NOAA or your national authority will notify the appropriate police department. Visit [www.cospas-sarsat.org](http://www.cospas-sarsat.org) for more detailed information.

## SECTION 3 – FALSE ALARMS

### 3.1 Prevention of false alarms

An ACR 406 MHz EPIRB can be activated in an emergency by two different methods. Whether you have a Category I or II, these methods are the same.

1. When the beacon is out of its bracket and in the water, the unit will start transmitting.
2. When the switch is moved to the “ON” position, in or out of the bracket, the unit will start transmitting.

There are a few precautions that should be taken to prevent false alarms.

- Do not mount or transport beacon within 3.3 ft/1 m of a magnetic source.
- Do not store beacon outside of its bracket if it can get wet.
- Do not mount EPIRB backwards in its bracket (lanyard roll must not be visible).
- Do not clean beacon with a water hose and brush while out of its bracket.

### 3.2 Reporting of false alarms

Should there be, for any reason, an inadvertent activation or false alarm, it must be reported to the nearest search and rescue authorities. The information that should be reported includes the EPIRB 15-digit Unique Identifier Number (UIN), date, time, duration and cause of activation, as well as location of beacon at the time of activation.

To Report False Alarms in the United States Contact any of the Following:

Atlantic Ocean / Gulf of Mexico

USCG Atlantic Area Command Center

Tel: (757) 398-6390

Pacific Ocean Area /

USCG Area Command Center

Tel: (510) 437-3700

USCG HQ Command Center

Tel: (800) 323-7233

To Report False Alarms Worldwide contact the national authority where your beacon is registered.

## SECTION 4 – INSTALLATION

### 4.1 Mounting location

The location selected must be sufficiently rigid to support the weight of the total installation and at the same time consider vibration, exposure to the elements, exposure to surrounding hazards, such as equipment movement, doors being opened, accidental covering, personnel traffic, etc., and yet be readily accessible at all times in the event of an emergency.

Also to be considered in selecting a location for installation is the harmful effect that certain corrosive vapors might have on the beacon. Under no circumstances should a beacon be jeopardized by any foreign articles being temporarily or permanently positioned during “at sea” or “in port” activities.

The beacon should face inboard on rail mount applications and should not be subjected to breaking waves.



**CAUTION:** Care must be taken to prevent any lanyard, line, or other emergency equipment that may be attached to the beacon from becoming entangled or fouled which could prevent the beacon from being removed in an emergency. Do not attach the beacon lanyard to the vessel or mounting bracket.

Do not mount the beacon 3.3 ft/1 m of strong magnetic or electrical fields, such as loud speakers, radar, high power radio transmitter or magnetic navigation compass.

Mount the beacon in a vertical (antenna upward) position. In certain circumstances, such as medical emergencies or disabled vessels, manual activation of the beacon for location and homing purposes is sometimes requested. Mounting in this orientation provides the best homing signal.

The Category I float-free mounting bracket should be mounted securely to a vertical or horizontal surface (the mount has predrilled holes for attachment to a flat surface) where there are no overhead obstructions. Location aboard a vessel must be chosen to allow the beacon to float free of sinking craft and as high as possible, especially on small vessels. This will help ensure operation of the hydrostatic release unit in the event the vessel capsizes without sinking. See section 4.3 on removing the HRU.

The Category I float-free mounting bracket should be securely attached to the vessel. The use of #10 stainless steel hardware (not included) is recommended.

### 4.2 Visual inspection

Visually inspect the area surrounding the mounting bracket installation site for hidden hazards, obstacles, etc., that may have been overlooked during location selection. If there is any doubt as to the ready accessibility to the beacon at all times or if any condition may appear to be questionable, make a complete and thorough investigation before making final approval of the installation.

### 4.3 Hydrostatic release unit (HRU) catagogy 1 beacon

The ACR HydroFix™ HRU has an expiration date of 2 years from the date of installation or 3 years from the date manufactured, whichever comes first. Upon installing your beacon or new HRU, permanently scratch the new expiration date on the HRU date calendar (as seen below).



Model: HRU-100 Part No. 9490

Expiry Date  
Gebrauchszeit

Validite  
Validita

2009		2010		2011	
JAN 1	FEB 2	MAR 3	APR 4	MAY 5	JUN 6
JUL 7	<del>AUG 8</del>	SEP 9	OCT 10	NOV 11	DEC 12

DISPOSE AFTER TWO YEARS FROM INSTALL DATE  
OR 3 YEARS FROM DATE MANUFACTURED

### Date of Installation Example:

Date of installation of New HRU or First Installation of EPIRB including new HRU: **August 1, 2007.**

This unit will need to be replaced in **August of 2009.** Scratch off "AUG 8" and "2006" on the HRU date calendar

### Date of Manufacture Example:

On the bottom of the HRU a date of manufacture is pin stamped: **0806.**

This unit will need to be replaced in **0809.** Scratch off "AUG 8" and "2009" on the HRU date calendar

The hydrostatic release can be replaced by removing the beacon from the bracket. Firmly press down on the spring at the bottom of the shelter, then slide the hydrostatic release assembly out of the keyed opening on the spring and mounting bracket. Discard the old HRU. Check the date manufactured on the bottom of the new HRU and insert the new hydrostatic release assembly in place by engaging it to the opening of the ejection spring and case. When replacing the HRU, ACR requires that you **do not reuse any parts from the previous HRU.** Failure to replace the entire assembly can cause the bracket to malfunction. Always use original ACR replacement parts (Replacement kit P/N 9490). Use of unauthorized replacement parts will void your warranty and may cause the bracket to malfunction. Place the beacon into the mounting bracket, (lanyard facing inward), and replace cover, securing in place with the cotter pin going through the hydrostatic release rod.

## SECTION 5 – ACTIVATION AND DEPLOYMENT

### 5.1 Bracket configuration

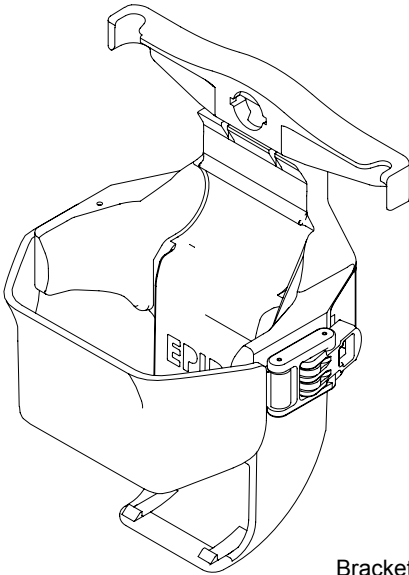

Bracket Configuration

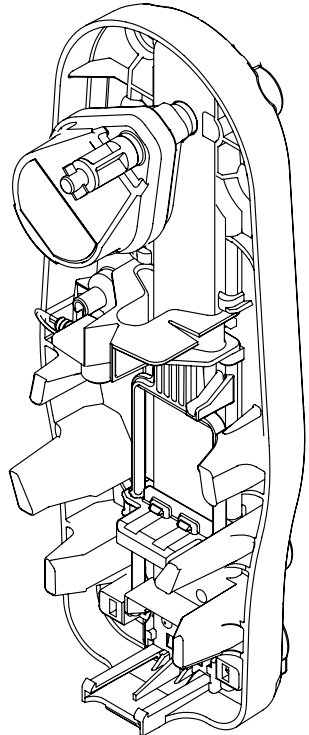
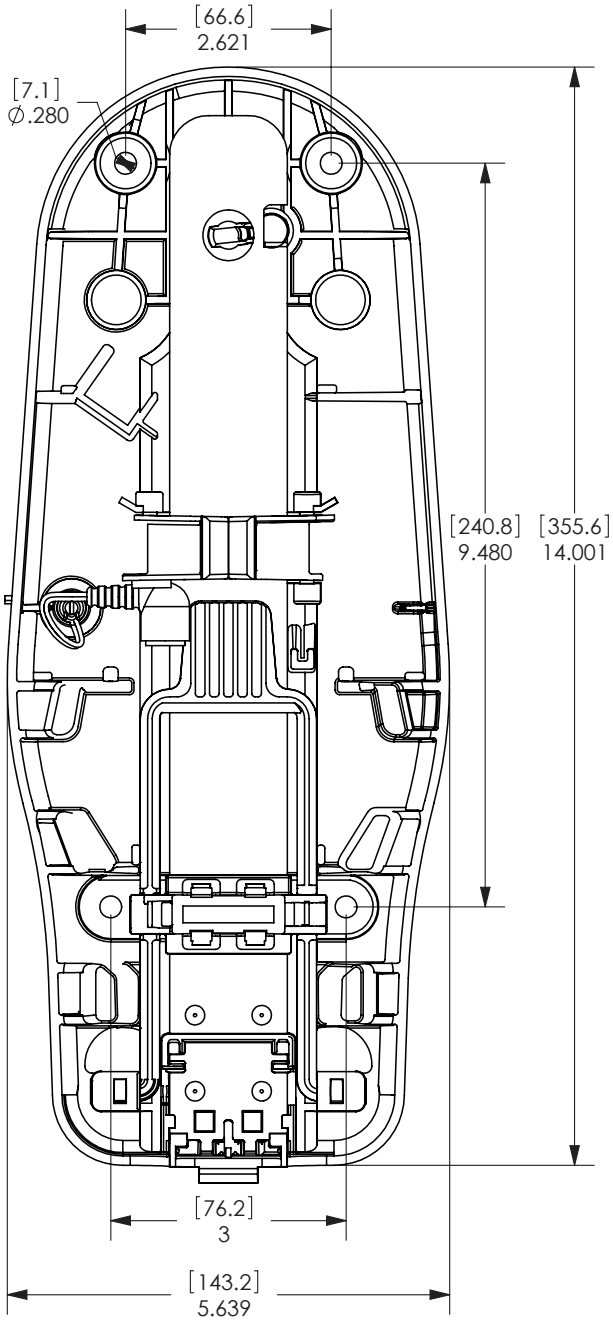

Figure 2

## 5.2 Category I & 2 bracket dimensions



Category I Bracket NOT TO SCALE

Figure 3

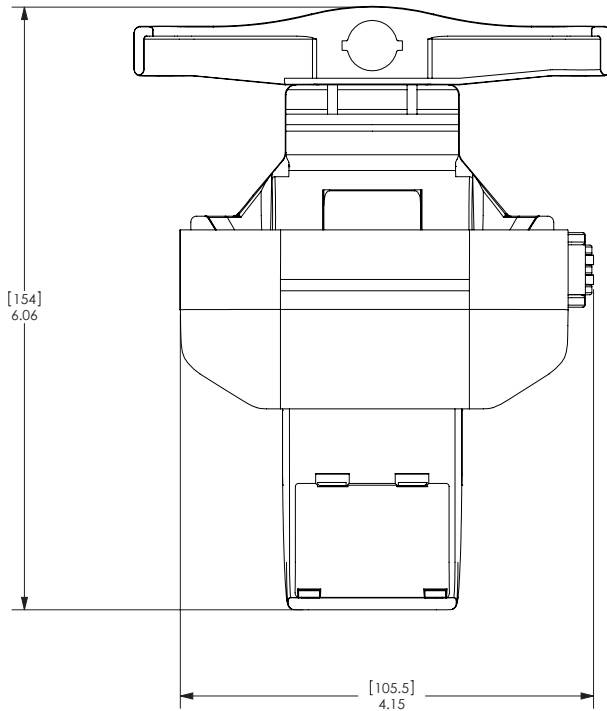

Category II Bracket Dimension Drawing NOT TO SCALE

Figure 4

### 5.3 Configuration overview

Category I beacons are designed to be automatically deployed and activated. The beacon may also be hand held on the deck of vessels, or floated in water and attached to a raft or life vest with the lanyard provided. Category II beacons are designed to be manually deployed from the bracket.

The beacon is designed to operate best while floating in water. Hand held operation should be avoided when possible. Do not operate inside life raft or under any similar cover or canopy. Use the lanyard to attach beacon to life raft or person after deployment. Caution - Do not attach lanyard to bracket or vessel. Both models of the beacon can be deployed and activated manually.

Changes in the laws governing beacons have mandated that the beacon be ready at all times. If certain criteria are met, the beacon will begin transmitting. The beacon is equipped with sensors to determine if it is in water (a deployment condition). Category I and II brackets both contain a magnet that interacts with other sensors in the beacon to prevent activation if it is wet (also a deployment condition).

Two conditions must be satisfied for the beacon to automatically activate:

- 1) **It must be out of its bracket**
- 2) **It must be in the water**

**Note:** Either condition by itself will not automatically activate the beacon.

The beacon is designed to allow the user to perform periodic testing while the beacon is in the release bracket.

**Category I:** Place the beacon into the release bracket with the spooled lanyard inward. The beacon should now be firmly held in the Category I bracket and ready for automatic deployment. Do not attach lanyard to bracket.

**Category II:** Place the beacon into the bracket with the spooled lanyard inward. The beacon should now be firmly held in the Category II bracket and ready for manual deployment. Do not attach lanyard to bracket. Use the strap and buckle to secure the beacon. The strap should be adjusted tight against the beacon; tight enough so that it is almost difficult to engage the buckle. This should be checked periodically.

## 5.4 Automatic deployment and activation - Category I Beacons

Automatic deployment and activation occurs if the vessel sinks and the hydrostatic release device frees the beacon from the bracket allowing it to float to the surface. Built-in sensors detect that the beacon is no longer in its bracket and is in water. This condition will automatically activate the beacon.

A category I RLB-36 automatically activates using the following sequence:

- Hydrostatic Release Unit (HRU) releases beacon
- Beacon becomes wet
- Water acts as conductor, electrical connection is made
- Beacon is activated

**NOTE:** TRANSMISSIONS OF THE 121.5 MHZ AND 406 MHZ SIGNAL WILL NOT OCCUR UNTIL 100 SECONDS AFTER ACTIVATION.

## 5.5 Manual deployment and activation

The Category I beacon can be manually deployed by removing the retaining pin, removing the cover, and then removing the beacon from the bracket. Once removed, both the Category I and Category II beacons can be activated by placing the beacon in water OR by lifting the thumb switch to a vertical position, sliding it toward the antenna and pushing down to the opposite side of the beacon. Activating the beacon in this manner breaks off the Activation Indicator Plastic Pin and allows the switch to properly seat, showing the “” symbol (ON).

A category I or category II RLB-36 manually activates with the following sequence:

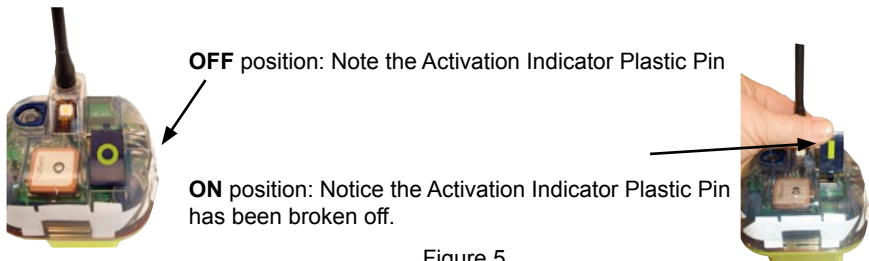

Figure 5

Remove the beacon from its bracket

Activation method one:

- Place beacon in water

Activation method two:

- Lift the switch to a vertical position
- Slide the switch toward the antenna
- Push the switch down to the opposite side of the beacon

Note: Some countries may fine vessel owners for causing false alarms. The permanent breakage of the Activation Indicator Plastic Pin is a positive indication of a manual activation.

## 5.6 Manual activation without deployment

The beacon can be activated while still in its bracket by placing the thumb switch in the ON position. Activation by this method overrides all sensors and turns the beacon “ON.” The caution note above still applies.

## 5.7 Deactivation

If manually activated, return the thumb switch to the “OFF” position.

If automatically activated: remove the beacon from the water. The beacon normally takes up to 12 seconds to deactivate, or place the beacon back into the release bracket.

If the beacon continues to operate after it has been deactivated, remove the four screws holding the unit together and unplug the battery to disable the unit. Return it to a service center for repair.

# SECTION - 6 INTERNAL AND EXTERNAL GPS

## 6.1 Self testing the beacon

The full functional self-test is initiated by momentarily lifting the thumb switch to a vertical position and holding it in this position for at least one second and at most 4 seconds. A beep indicates the initiation of the test, and the self test will attempt 5 functional test sequence as described in Figure 6. The first red/green LED flash indicates if the electronic witness is broken. Then if all tests pass, the buzzer will beep an additional five times as the green LED lights simultaneously. The last green LED flash and the smiley faces shown on the display indicates a successful test. However, if the test fails at any step, there will be no beep and the red LED will flash with the “x” shown on the display. The self-test will stop at that step. During the self-test, an actual satellite message is transmitted while certain key performance parameters are measured and recorded. The self-test message is modified to prevent the satellite from forwarding an alert message during self-test.

The RLB-36 beacon may be self-tested as much as is warranted, up to a maximum of 60 (sixty) times in the 5 (five) year life of the battery, or once per month for the life of the battery.





















TEST	DISPLAY	SUCCESS	FAIL
EEPROM Connect		Beep,  Green LED	Test Stopped  Red LED 
Lock Circuit	<b>PLL</b> <input checked="" type="checkbox"/>	Beep,  Green LED	Test Stopped  Red LED 
Signal Strength	<b>406</b> <input checked="" type="checkbox"/>	Beep,  GreenLED	Test Stopped  Red LED 
GPS Ready	<b>GPS</b> <input checked="" type="checkbox"/>	Beep,  Green LED	Test Stopped  Red LED 
Locator Light	 <input checked="" type="checkbox"/>	Beep,  Green LED, Strobe	Test Stopped  Red LED 
Summary	   <input checked="" type="checkbox"/>	 Green LED	

Figure 6

\*NOTE: The “beeps” are a very high-pitched tone that some people may not hear. When performing the self test, count the red LED flashes .

## 6.2 GPS acquisition with the external GPS

The RLB-36 is fitted with an optical interface to connect with an external Global Positioning System receiver that will determine the latitude and longitude of its position to be transmitted to the emergency system. When RLB-36 is coupled to a working external GPS receiver, it immediately begins downloading data. Once valid position data has been obtained, the beacon will attempt to update the positional data every 20 minutes. The RLB-36 will store the last valid positional data for up to 4 hours, if it becomes unable to obtain new updated data. It will update this data if and only if it receives new good positional data from the external GPS receiver.

The black lead wire with white stripes should be connected to the positive transmitter pin. The black wire should be connected to the negative pin.

If the external GPS receiver is operational and the connection has been correctly made to the optical interface, the green LED in the optical interface will start flashing.

NOTE: The baud rate output for your GPS receiver NMEA 0183 should be 4800 bps. If you are not sure if your receiver is NMEA 0183 compliant, check the interface settings listed in your GPS manual. To optimize your GPS Interface feature be sure that your GPS receiver is equipped with a NMEA 0183 Version 1.5 or higher with GPGGA sentence enabled.

## 6.3 Using the external GPS interface

Once a compatible, operating GPS receiver is connected to RLB-36, the beacon will store data for incorporation into the emergency message, which is transmitted to the satellite when it is activated in an emergency. This can provide more accurate positioning data to the Search and Rescue Authority and may lead to a faster rescue. Since the last valid GPS

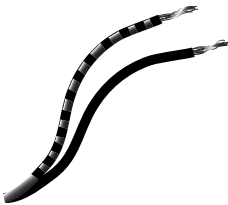

NMEA Cable Wires

Figure 7

position data may stay in the memory for up to 4 hours, the user should take care to make sure that the GPS position data stored is accurate. This can be accomplished by two methods: first, by always leaving a properly functioning GPS connected to the beacon before activation and second, by connecting a properly functioning GPS with a valid position fix and allowing sufficient time to acquire valid GPS position data. This will take a nominal 20 minutes if old GPS position data is stored in the memory. If there is no old GPS position data present, the beacon will acquire current data within a minute of being connected to a GPS with a valid position fix. You can force the beacon to update its position at any time by connecting to a GPS with a valid position

fix and initiating the Self-Test. If no valid GPS position data is available, the beacon will keep the previously stored GPS position data for up to 4 hours. In this case, call ACR Customer Service at +1 (954) 981-3933 for instructions on how to reset the beacon with the default message.

## 6.4 Testing the external GPS interface

Connect the optical interface plug to the beacon bezel and allow sufficient time for the GPS receiver to acquire valid GPS position data (usually less than 1 minute; but it can take up to 20 minutes). Lift the thumb switch to the vertical (Self-Test) position and release. Your beacon will confirm that it has acquired valid GPS data by displaying the latitude and longitude coordinates on the display. This will occur after the “smiley faces” are displayed at the end of Self-Test.

## 6.5 Updating the external GPS position data

When the beacon is properly connected to a functioning and compatible GPS receiver, GPS position data is automatically updated about every 20 minutes, while valid GPS position data

is present. The operator can force the acquisition of new GPS position data, by executing a Self-Test with the beacon connected to a GPS with a valid position fix. This bypasses the normal, programmed, waiting time of 20 minutes for the automatic update of GPS position data. If the new GPS position is acquired, the coordinates will be displayed, after the beacon has completed the Self-Test.

A new beacon is programmed with the GPS position data set to “default.” This default GPS position data indicates, upon activation, to the satellite system that the beacon has no valid GPS position stored in memory. Once a functioning and compatible GPS receiver is properly connected to the beacon, this “default” data will be replaced by valid GPS position data, as described in the previous sections.

## 6.6 Internal GPS navigation system

The RLB-36 is fitted with an internal Global Positioning System receiver that will determine the navigational coordinates, latitude and longitude, of its position on the globe to be transmitted to the emergency system. The internal GPS will be formatted in accordance with the NMEA-0183 interface. The serial rate will be 9600 baud, eight data bits, no parity and one stop bit. When the RLB-36 is turned on the GPS is immediately turned on and it attempts to acquire good navigation data for a period of 30 minutes. If the GPS receiver obtains good data anytime in this period or the 30 minutes elapses, the GPS receiver is turned off for 20 minutes and 45 seconds. This is to prevent an update from happening in less than 20 minutes. GPS data can be acquired anytime the GPS is on, but only good quality factor data is recognized and saved. Once the beacon acquires good quality GPS data in this manner it puts the GPS data into the next transmitted 406 MHz digital message. After the GPS is turned off for 20 minutes and 45 seconds, the GPS is turned on for ten minutes to attempt to acquire or update good navigation data. If the GPS acquires good data or the 10-minute period elapses, the GPS is turned off for another 20 minutes and 45 seconds. The third time the beacon looks for GPS data the GPS is turned on for 5 minutes. From then on each GPS on time is 5 minutes and each following off period is increased by an additional 9 minutes until the GPS has been on for a total of 18 periods, at this time the off time the GPS engine reaches 2.5 hours, then it turns on for 5 minutes then off for 2.5 hours, till the battery dies out.

## 6.7 Internal GPS Testing

This test is NOT required as 100% of all GPS receivers that leave ACR have been tested to ensure they perform perfectly. However, if you would like to ensure your GPS receiver is working, please follow these instructions very closely.



**Warning:** To conserve battery power the following test should not be performed more than once during the five-year life of the battery pack!

Note: The GPS receiver is located under the top cap (next to the thumb switch). It is imperative that the receiver is not obstructed during self test or activation to ensure that the GPS receiver is acquiring your latitude (LAT) and longitude (LON) position. **This test must be performed outside with a clear view of the sky.**

To test the internal GPS you must be outdoors and have a clear view of the sky. Observe the beacon for the entire GPS test. Lift the thumb switch to vertical position and hold it in this position for at least 9 seconds. The “GPS” will display on the OLED and a beep will indicate that the GPS has been turned on. The GPS will remain ON until LAT/LON coordinates have been obtained or until 10 minutes have elapsed. If good navigation data has been obtained, the GPS will be turned OFF and the coordinates will be displayed on the OLED display. The LAT/LON data is not saved for use when then beacon is turned on and there is no RF burst during this GPS test. This is only to proof that the GPS is functioning properly and that the beacon is in a location or environment where it can receive the necessary signals from satellites. If the GPS does not acquire good navigation data, the GPS will turn OFF after 10 minutes.

## 6.8 LED indication of GPS fix

When the RLB-36 is in On mode, the red LED, Light Emitting Diode, flashes every 1 second for the first hour then 3 seconds after to indicate the RLB-36 is turned on and operating. As soon as the GPS receiver acquires good navigational data the red LED stops blinking and the green LED flashes once every two seconds to indicate that the internal GPS receiver has acquired good navigational data. The color of the On mode LED that flashes once every 1 or 3 seconds in On mode always indicates whether the 406 message being transmitted contains good navigation data or default data. Green indicates good navigation data, red indicates default data. Once good navigation data is acquired, the data is put into the digital message of the next 406 MHz transmitted burst. If for any reason a time period of 4 hours passes without the GPS receiver being able to update the last good set of navigational data, the message transmitted by the RLB-36 will revert back to default data. At this point the green LED will stop blinking and the red LED will flash 1 every 3 seconds. If at any time after this, good navigational data is obtained, the green LED will flash, this new data will be transmitted in the following burst and the green LED will continue to flash once every 3 seconds.

## 6.9 OLED display

The Organic Light- Emitting Diode (OLED) display in the beacon is used as a secondary indicator, supporting the green/red LED and the beep sound to indicate the status of the beacon during the self test and emergency operation.

In self test, the OLED displays the test result of each step with “√” indicating a pass and “X” indicating a failure. There are total five test steps: EEPROM content, phase locker loop, 406 power output, internal GPS module and the strobe light. If all tests pass, “smiley face” emoticons will be displayed at the end of the self test mode. This will be followed by the GPS coordinates horizontally scrolling through the display, provided the beacon has a downloaded external GPS location.

A long GPS test may be invoked by holding the switch in test position after self test completes. The display will show the letters “GPS” moving left and right while the internal GPS is acquiring coordinates data. Once the data is acquired, the coordinates will scroll through the display as a confirmation that the data was successfully acquired.

When the beacon is activated, the display will show a brief welcome message. The beacon then begins to send 406 MHz emergency signal bursts. After each 406 burst, indicated by a beep, GPS coordinates will be displayed, provided the data was acquired. The display animates the sending of the 406 message. The display also provides a battery gauge which appears for approximately 10 seconds each time between the 406 bursts.

# SECTION 7 – CARE AND MAINTENANCE

## 7.1 Routine maintenance

At least every ninety days, the float free mounting bracket and beacon should be inspected for deterioration and/or residue buildup that may affect the function of the beacon or automatic release. Part of the visual check includes checking the antenna for tightness. Clean the beacon and the mounting bracket to remove residue buildups. It is recommended that the beacon and mounting bracket be wiped with a damp cloth.

Carefully inspect the beacon case for any visible cracks. Cracks may admit moisture, which could falsely activate the beacon or otherwise cause a malfunction. Any cracking observed should be immediately referred to ACR for evaluation by calling 1-800-432-0227 ext. 2155 in the US, or +1-954-981-3333 ext 2155 elsewhere.

## 7.2 Battery replacement

The battery must be replaced by the date indicated on the beacon or every five (5) years, whichever occurs first. At each inspection, check the time remaining until replacement is required. The battery should be replaced if the beacon has been activated for any use other than the self test.



Always refer all long life battery replacement and other beacon service to a factory authorized service center. Battery replacement includes servicing the beacon by replacing all o-rings, testing the water seal and the electrical properties.

**NOTE:** There are no user serviceable items inside the beacon. DO NOT OPEN THE BEACON UNLESS TO DISABLE IN CASE OF FAULTY ACTIVATION.

For the nearest location of a Battery Replacement Center, visit our website at [www.acelectronics.com](http://www.acelectronics.com)

The beacon may or may not require special shipping instructions due to the lithium batteries and changes in shipping regulations. Please refer to ACR's website [www.acelectronics.com](http://www.acelectronics.com) for proper shipping instructions.

### 7.3 Shore based maintenance for SOLAS Vessels

SBM) IMO MSC/Circ. 1039

The Maritime Safety Committee approved guidelines for shore-based maintenance of satellite beacons, for the purpose of establishing standardized procedures and minimum levels of service for the testing and maintenance of satellite beacons. First Shore Based Maintenance on all ACR EPIRBs is due at the date of the first battery replacement.

### 7.4 Annual testing for SOLAS vessels, IMO MSC/Circ. 1040

SOLAS regulation IV/15.9 dictates annual testing of 406 MHz satellite EPIRBs. Testing should be carried out using suitable test equipment capable of performing the relevant measurements. All checks of electrical parameters should be performed in the self-test mode, if possible.

## SECTION 8 – THE SEARCH AND RESCUE SYSTEM

### 8.1 General overview

Beacons provide distress alerts via radio transmission on 406 MHz to the LEOSAR satellites of the COSPAS-SARSAT network. The beacon can also transmit a distress alert (acquired by the internal or external GPS) to the GEOSAR network that includes GPS latitude and longitude coordinates.

The message transmitted is unique for each beacon, which provides identification of the transmitter through computer access of registration files maintained by the National Oceanic and Atmospheric Administration or other national authority\*. Remember, SAR forces will know who you are, what type of vessel you have, your home port, and who to contact that might know of your current situation ONLY if your beacon has been properly registered. This will help expedite the launch of a rescue operation. 406 MHz beacons are required to have their registration updated every two years.

\*The national authority is the governmental body responsible for EPIRB registration database administration for the country for which the EPIRB is programmed.

Once the 406 MHz signal is relayed through the LEOSAR and/or GEOSAR network, SAR forces determine who is closest, and then proceed to the beacon using the 121.5 MHz homing frequency.

### 8.2 Satellite detection

EPIRBs transmit to the satellite portion of the COSPAS-SARSAT system. COSPAS-SARSAT is an international

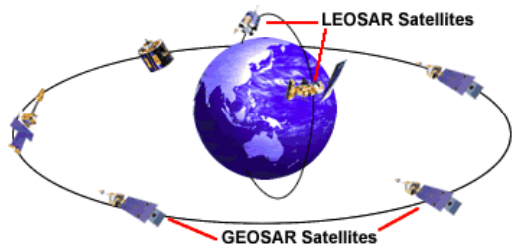

Figure 9 - Satellite Coverage

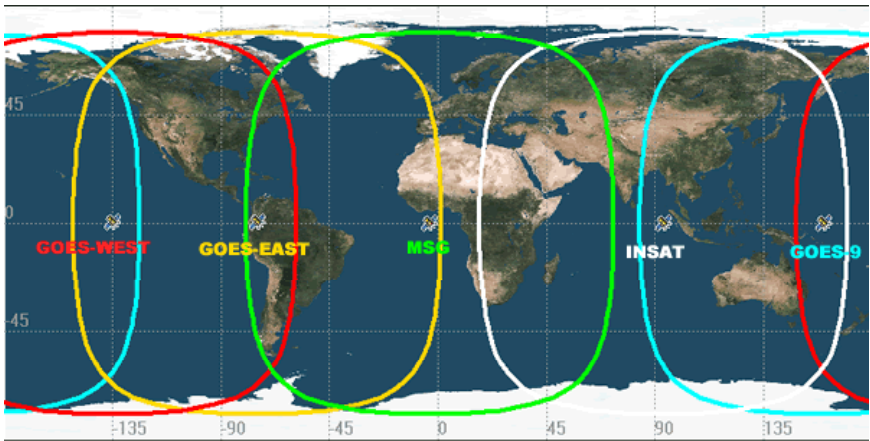

Figure 10 - GEOSAR Satellite Orbits

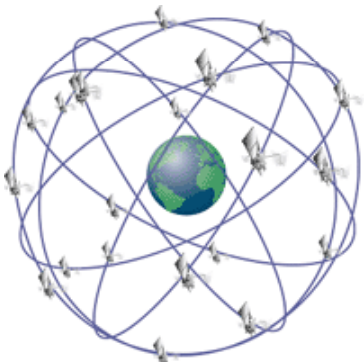

Figure 11 - GPS Satellite Orbits

system that utilizes Russian Federation and United States' low altitude, near-polar orbiting satellites (LEOSAR). These satellites assist in detecting and locating activated 406 MHz satellite beacons.

COSPAS and SARSAT satellites receive distress signals from EPIRBs transmitting on the frequency of 406 MHz. The COSPAS-SARSAT 406 MHz beacon signal consists of a transmission of non-modulated carriers followed by a digital message format that provides identification data. The 406 MHz system uses Satellite-borne equipment to measure and store the Doppler-shifted frequency along with the beacon's digital

data message and time of measurement. This information is transmitted in real time to an earth station called the Local User Terminal (LUT), which may be within the view of the satellite, as well as being stored for later transmission to other LUTs.

The LUT processes the Doppler-shifted signal from the LEOSAR and determines the location of the beacon, then the LUT relays the position of the distress to a Mission Control Center (MCC) where the distress alert and location information is immediately forwarded to an appropriate Rescue Coordination Center (RCC). The RCC dispatches Search and Rescue (SAR) forces.

The addition of the GEOSAR satellite system greatly improves the reaction time for a SAR event. This satellite system has no Doppler capabilities at 406 MHz, but will relay the distress alert to any of the LUT stations. When there is GPS data included in the distress message, SAR authorities instantly know your location to within 110 yards (100 m). This speeds up the reaction time by not having to wait for one of the LEOSAR satellite to pass overhead. Because most of the search and rescue forces presently are not equipped to home in on the 406 MHz Satellite beacons signal, homing must be accomplished at 121.5 MHz.

### 8.3 Global Positioning System (GPS)

The GPS system is a satellite group that enables a GPS receiver to determine its exact position to within 30 m (100 ft.) anywhere on earth. With a minimum of 24 GPS satellites orbiting the earth at an altitude of approximately 11,000 miles they provide users with accurate information on position, velocity, and time anywhere in the world and in all weather conditions.

The GlobalFix™ stores this data into its distress transmission allowing search and rescue forces to narrow the search into a very small area and thus minimize the resources required and dramatically increase the effectiveness of the overall operation.

## SECTION 9 – TECHNICAL INFORMATION

### 9.1 Type approvals and standards

The RLB-35 meets the requirements of Federal Communication Commission (FCC) Part 80 and Category I EPIRBs meet the GMDSS requirements:

TYPE APPROVALS	
FCC	FCC ID: B66ACR-RLB35 (RLB-35)
COSPAS-SARSAT	Certificate Nos. 136, 173
MED	BSH Certificate No. 4612/506 0016/2005 Notified Body: 0735 

Copies of certificates and additional worldwide type approvals are available at: [www.acelectronics.com](http://www.acelectronics.com).

APPLICABLE STANDARDS	
FCC	Part 80 Subpart V – EPIRBs Part 80 Subpart W – GMDSS (Cat. 1 only)
RTCM	RTCM Recommended Standards for 406 MHz Satellite EPIRBs
COSPAS/SARSAT	C/S T.001 – Specification for C/S 406 MHz Distress Beacons C/S T.007 – C/S 406 MHz Distress Beacon Type Approval Standard
MED	Annex A.1, Item No. A.1/5.6 – 406 MHz (C/S) Satellite EPIRB

### 9.2 Specifications

GENERAL/ENVIRONMENTAL	
Beacon size (without antenna)	17.7 H X 10.67W X 9.09 D cm (6.97 X 4.2 X 3.58 inches)
OLED size	1.0" diagonal
Beacon weight	581 g (18.68 troy oz)
Beacon material	High impact UV resistant polymer
Color	ACR-treuse™ (high visibility yellow)
Waterproof	10 min @10 m (33 ft), exceeds RTCM standard
Buoyant	Yes
Deployment	Category I: Automatic hydrostatic release Category II: Manual
BATTERY	
Operational life	48 hours minimum @-20°C (-4°F) (Class 2)
Battery type	LiMNO2
Battery replacement interval	5 years or after use in an emergency
Operating temperatures	-20° C to +55° C (-4° F to +131° F) (Class 2)
Storage temperatures	-30° C to +70° C (-22° F to +158° F) (Class 2)

<b>406 MHz TRANSMITTER</b>	
Frequency	406 MHz
Power output	5 W
Digital message format	Standard location protocol (for the USA; Beacon can be reprogrammed at a service center to other coded formats, and to national location protocol)
Duration	520 ms
Frequency stability	+/- 2 bp/100 ms
Rate	400 bps
Modulation	+/- 1.1 radians
Encoding	Biphase L
<b>121.5 MHz TRANSMITTER</b>	
Frequency	121.5 MHz
Frequency tolerance	+/-50 ppm
Power output	25 mW PEP
Modulation type	AM (3K20A3X)
Sweep range	400- 1200 Hz
Sweep rate	3 Hz
Duty cycle	37.5%
<b>STROBE</b>	
Light color	White
Output power	0.75 effective candela
Flash rate	20- 30/ min
<b>ANTENNA</b>	
Height	21.21 cm (8.35 in)
Frequency	406 MHz, 121.5 MHz
Polarization	Vertical
VSWR	Less than 1.5/1
GPS antenna	12 channel parallel receiver
<b>GENERAL</b>	
Accessories	Category I Mounting Case, ACR Part Number A3-06-2577 Category II Mounting Brackets, ACR Part Number A3-06-2578 Universal Hydrostatic Release (HRU) Kit, ACR Part Number A3-06-2429-3 Replacement antenna, ACR Part Number A3-06-2554

### 9.3 Support

ISSUE	CONTACT	TELEPHONE or WEBSITE
Possible damage to beacon	ACR Electronics, Inc.	US: 1-800- 432- 0227, extension 2155 Outside the US: +1-954-981-3333, extension 2155
Resetting beacon to allow downloading new GPS coordinates	ACR Electronics, Inc.	+1-954-981-3333
General trouble with new beacon	ACR Electronics, Inc.	1-800- 432- 0227

### 9.4 Beacon Images



Beacon standing upright



Beacon floating in water



Beacon held in hand