

Aviation Communication and Surveillance Systems  
19810 North 7th Avenue  
Phoenix, Arizona 85027-4400  
U.S.A.

# **TCAS 3000 Traffic Alert and Collision Avoidance System**

## **System Description and Installation Manual**

**34-43-23**

TITLE PAGE T-1

15 DECEMBER 2005



**SYSTEM DESCRIPTION AND INSTALLATION MANUAL**  
TCAS 3000 Traffic Alert and Collision Avoidance System

**PROPRIETARY NOTICE**

This document and the information disclosed herein are proprietary data of ACSS. Neither this document nor the information contained herein shall be used, reproduced, or disclosed to others without the written authorization of ACSS, except to the extent required for installation or maintenance of the recipient's equipment.

NOTICE – FREEDOM OF INFORMATION ACT (5 USC 552) AND DISCLOSURE OF  
CONFIDENTIAL INFORMATION GENERALLY (18 USC 1905)

This document is being furnished in confidence by ACSS. The information disclosed herein falls within exemption (b) (4) of 5 USC 552 and the prohibitions of 18 USC 1905.

S2005

*ACSS is a U.S. registered trademark.  
All other marks are owned by their respective companies.*

**34-43-23**  
TITLE PAGE T-2

15 DECEMBER 2005

Copyright 2005 ACSS  
All Rights Reserved





**SYSTEM DESCRIPTION AND INSTALLATION MANUAL**  
TCAS 3000 Traffic Alert and Collision Avoidance System

Blank Page





**SYSTEM DESCRIPTION AND INSTALLATION MANUAL**  
TCAS 3000 Traffic Alert and Collision Avoidance System

Blank Page



**SYSTEM DESCRIPTION AND INSTALLATION MANUAL**  
TCAS 3000 Traffic Alert and Collision Avoidance System

**SERVICE BULLETIN LIST**

Service Bulletin	Identified Mod	Date Included in this Manual	Description



**SYSTEM DESCRIPTION AND INSTALLATION MANUAL**  
TCAS 3000 Traffic Alert and Collision Avoidance System

**LIST OF EFFECTIVE PAGES**

Original - . . . 15 Dec 2005

<u>Subheading and Page</u>	<u>Revision</u>	<u>Subheading and Page</u>	<u>Revision</u>
Title		Introduction	
T-1	-	INTRO-1	-
T-2	-	INTRO-2	-
		INTRO-3	-
Record of Revisions		INTRO-4	-
RR-1	-	INTRO-5	-
RR-2	-	INTRO-6	-
Record of Temporary Revisions		System Description	
RTR-1	-	1-1	-
RTR-2	-	1-2	-
		1-3	-
Service Bulletin List		1-4	-
SBL-1	-	1-5	-
SBL-2	-	1-6	-
		1-7	-
List of Effective Pages		1-8	-
LEP-1	-	1-9	-
LEP-2	-	1-10	-
LEP-3	-	1-11	-
LEP-4	-	1-12	-
		1-13	-
Table of Contents		1-14	-
TC-1	-	F 1-15/1-16	-
TC-2	-	1-17	-
TC-3	-	1-18	-
TC-4	-	1-19	-
TC-5	-	1-20	-
TC-6	-	1-21	-
TC-7	-	1-22	-
TC-8	-	1-23	-
TC-9	-	1-24	-
TC-10	-	1-25	-
		1-26	-
		1-27	-
		1-28	-

■ indicates changed, added, or deleted page.  
F indicates right foldout page with blank back.





**SYSTEM DESCRIPTION AND INSTALLATION MANUAL**  
 TCAS 3000 Traffic Alert and Collision Avoidance System

<u>Subheading and Page</u>	<u>Revision</u>	<u>Subheading and Page</u>	<u>Revision</u>
1-29	-	2-6	-
1-30	-	F 2-7/2-8	-
1-31	-	F 2-9/2-10	-
1-32	-	F 2-11/2-12	-
1-33	-	F 2-13/2-14	-
1-34	-	F 2-15/2-16	-
1-35	-	F 2-17/2-18	-
1-36	-	2-19	-
1-37	-	2-20	-
1-38	-	F 2-21/2-22	-
1-39	-	F 2-23/2-24	-
1-40	-	F 2-25/2-26	-
1-41	-	F 2-27/2-28	-
1-42	-	F 2-29/2-30	-
1-43	-	F 2-31/2-32	-
1-44	-	F 2-33/2-34	-
1-45	-	F 2-35/2-36	-
1-46	-	F 2-37/2-38	-
1-47	-	F 2-39/2-40	-
1-48	-	F 2-41/2-42	-
1-49	-	F 2-43/2-44	-
1-50	-	F 2-45/2-46	-
1-51	-	F 2-47/2-48	-
1-52	-	F 2-49/2-50	-
1-53	-	F 2-51/2-52	-
1-54	-	F 2-53/2-54	-
1-55	-	F 2-55/2-56	-
1-56	-		
1-57	-	Electrical Installation	
1-58	-	3-1	-
1-59	-	3-2	-
1-60	-	F 3-3/3-4	-
1-61	-	F 3-5/3-6	-
1-62	-	F 3-7/3-8	-
1-63	-	F 3-9/3-10	-
1-64	-	F 3-11/3-12	-
		F 3-13/3-14	-
Mechanical Installation		F 3-15/3-16	-
2-1	-	3-17	-
2-2	-	3-18	-
2-3	-	3-19	-
2-4	-	3-20	-
2-5	-	3-21	-



# SYSTEM DESCRIPTION AND INSTALLATION MANUAL

TCAS 3000 Traffic Alert and Collision Avoidance System

<u>Subheading and Page</u>	<u>Revision</u>	<u>Subheading and Page</u>	<u>Revision</u>
3-22	-	4-5	-
3-23	-	4-6	-
3-24	-	4-7	-
3-25	-	4-8	-
3-26	-	4-9	-
3-27	-	4-10	-
3-28	-	4-11	-
3-29	-	4-12	-
3-30	-	4-13	-
3-31	-	4-14	-
3-32	-	4-15	-
3-33	-	4-16	-
3-34	-	4-17	-
3-35	-	4-18	-
3-36	-	4-19	-
3-37	-	4-20	-
3-38	-	4-21	-
3-39	-	4-22	-
3-40	-	4-23	-
3-41	-	4-24	-
3-42	-	4-25	-
3-43	-	4-26	-
3-44	-	4-27	-
3-45	-	4-28	-
3-46	-	4-29	-
3-47	-	4-30	-
3-48	-	4-31	-
3-49	-	4-32	-
3-50	-	4-33	-
3-51	-	4-34	-
3-52	-	4-35	-
3-53	-	4-36	-
3-54	-	4-37	-
3-55	-	4-38	-
3-56	-	4-39	-
3-57	-	4-40	-
3-58	-	4-41	-
		4-42	-
Loading/Gradient Specifications		4-43	-
4-1	-	4-44	-
4-2	-	4-45	-
4-3	-	4-46	-
4-4	-	4-47	-



**SYSTEM DESCRIPTION AND INSTALLATION MANUAL**  
TCAS 3000 Traffic Alert and Collision Avoidance System

<u>Subheading and Page</u>	<u>Revision</u>	<u>Subheading and Page</u>	<u>Revision</u>
4-48	-	6-17	-
4-49	-	6-18	-
4-50	-	6-19	-
4-51	-	6-20	-
4-52	-	6-21	-
4-53	-	6-22	-
4-54	-	6-23	-
4-55	-	6-24	-
4-56	-		
		Maintenance Practices	
Adjustment/Test		7-1	-
5-1	-	7-2	-
5-2	-	7-3	-
5-3	-	7-4	-
5-4	-	7-5	-
5-5	-	7-6	-
5-6	-	7-7	-
5-7	-	7-8	-
5-8	-	7-9	-
5-9	-	7-10	-
5-10	-	7-11	-
5-11	-	7-12	-
5-12	-		
5-13	-	Inspection/Check	
5-14	-	8-1	-
		8-2	-
Fault Isolation			
6-1	-	Cleaning/Painting	
6-2	-	9-1	-
6-3	-	9-2	-
6-4	-	9-3	-
6-5	-	9-4	-
6-6	-	9-5	-
6-7	-	9-6	-
6-8	-		
6-9	-	Repairs	
6-10	-	10-1	-
6-11	-	10-2	-
6-12	-		
6-13	-		
6-14	-		
6-15	-		
6-16	-		



SYSTEM DESCRIPTION AND INSTALLATION MANUAL
TCAS 3000 Traffic Alert and Collision Avoidance System

TABLE OF CONTENTS

Section Page
INTRODUCTION INTRO-1
1. General INTRO-1
2. Reference Documents INTRO-1
3. Weights and Measurements INTRO-1
4. Acronyms and Abbreviations INTRO-2
5. Special Precautions INTRO-5
SYSTEM DESCRIPTION 1-1
1. General 1-1
2. System Components 1-1
3. System Description 1-7
A. System Functional Description 1-7
B. System Configurations 1-11
4. Component Descriptions 1-17
A. RT-950/951 TCAS Computer Unit 1-17
(1) System Interfaces 1-21
(2) Discrete Inputs 1-24
(3) Program Inputs 1-24
(4) Discrete Outputs 1-24
(5) Self-Test Function 1-24
B. Directional Antenna 1-25
C. ACSS Mode S/TCAS Control Panels 1-28
(1) Functional Description and Operation 1-29
D. Gables ATC/TCAS Dual Mode S Transponder Control Panel 1-30
(1) Functional Description and Operation 1-32
E. VSI/TRA Display 1-34
(1) Functional Description and Operation 1-36
(2) Software Considerations 1-37
(3) Built-In Test Equipment (BITE) and Self-Test Capability 1-37
F. Pressure Transducer Module 1-40
G. XS-950 Mode S Data Link Transponder 1-42
H. RCZ-852 Diversity Mode S Transponder 1-47



**SYSTEM DESCRIPTION AND INSTALLATION MANUAL**  
TCAS 3000 Traffic Alert and Collision Avoidance System

<b>Section</b>	<b>Page</b>
5. System Operation .....	1-51
A. Operational Modes .....	1-51
(1) TCAS Modes .....	1-51
(2) Non-TCAS Modes .....	1-52
(3) Extended Test Mode .....	1-52
B. Display Symbology .....	1-53
(1) Colors .....	1-53
(2) Traffic Identification .....	1-54
(3) Data Tags .....	1-54
(4) VSI Scale Overlays .....	1-55
(5) Reference Graphics and Annunciations .....	1-55
C. Aural Messages .....	1-55
(1) Requirements and Limitations .....	1-55
(2) Traffic Advisory (TA) Message .....	1-56
(3) Resolution Advisory (RA) Messages .....	1-56
(4) Enhanced RA Messages .....	1-57
D. Operating Procedures .....	1-58
(1) Pre-Flight Test .....	1-58
(2) TCAS Mode Activation .....	1-59
(3) TCAS Mode Deactivation .....	1-59
<b>MECHANICAL INSTALLATION .....</b>	<b>2-1</b>
1. General .....	2-1
2. Equipment and Materials .....	2-1
3. Mechanical Installation Design .....	2-1
A. RT-950/951 TCAS Computer Unit Provisions .....	2-1
B. Antenna Provisions .....	2-2
(1) Directional Antenna Installation .....	2-2
(2) Omnidirectional Antenna Installation .....	2-2
C. Control Panel Provisions .....	2-3
D. VSI/TRA Provisions .....	2-3
E. Pressure Transducer Module (PTM) Provisions .....	2-3



# SYSTEM DESCRIPTION AND INSTALLATION MANUAL

TCAS 3000 Traffic Alert and Collision Avoidance System

<u>Section</u>	<u>Page</u>
F. Transponder Provisions .....	2-4
(1) Mode S Data Link Transponder Provisions .....	2-4
(2) Diversity Mode S Transponder Provisions .....	2-4
(3) ATC Transponder Antenna Provisions .....	2-4
<b>ELECTRICAL INSTALLATION .....</b>	<b>3-1</b>
1. General .....	3-1
2. Equipment and Materials .....	3-1
3. Electrical Installation Procedure .....	3-1
4. Electrical Installation .....	3-1
A. RT-950/951 TCAS Computer Units .....	3-1
B. TCAS Antennas .....	3-1
C. Control Panels .....	3-23
D. VSI/TRA Displays .....	3-31
E. Pressure Transducer Module .....	3-39
F. Transponders .....	3-40
(1) XS-950 Data Link Transponder .....	3-40
(2) RCZ-852 Diversity Mode S Transponder .....	3-49
<b>LOADING/GRADIENT SPECIFICATIONS .....</b>	<b>4-1</b>
1. General .....	4-1
2. Loading and Gradient Specifications .....	4-1
<b>ADJUSTMENT/TEST .....</b>	<b>5-1</b>
1. General .....	5-1
2. Equipment and Materials .....	5-1
3. Initial Harness Checkout (New Installations Only) .....	5-1
A. TCAS Computer Unit Harness Checkout .....	5-1
B. TCAS Controller and Display Unit Harness Checkout .....	5-1
C. LRU Preinstallation Power Checkout .....	5-2
D. Initial System Installation Operational Test .....	5-2



**SYSTEM DESCRIPTION AND INSTALLATION MANUAL**  
TCAS 3000 Traffic Alert and Collision Avoidance System

<b>Section</b>	<b>Page</b>
4. System Self-Tests .....	5-3
A. Cockpit Display Test Modes .....	5-3
(1) Short Test Mode .....	5-3
(2) Extended Test Mode .....	5-4
B. TCAS Computer Unit Self-Test .....	5-5
5. Return to Service Test .....	5-6
6. Operational Software Loading Using an ARINC Portable Data Loader .....	5-6
A. Current Software Verification .....	5-6
B. Operational Software Loading (While Installed on Aircraft) .....	5-6
C. Compact Flash Card (while installed on aircraft) .....	5-7
(1) Procedure for Uploading OPS SW Through Compact Flash Card .....	5-7
D. Updated Software Verification .....	5-11
(1) Software Verification Using Cockpit Systems ONLY .....	5-11
(2) Software Verification Using a Stand-Alone PC ONLY .....	5-11
(3) Software Verification Using a Software Verification Fixture ONLY .....	5-13
(4) Software Verification Using a Remote Connected VSI/TRA ONLY .....	5-13
<b>FAULT ISOLATION .....</b>	<b>6-1</b>
1. General .....	6-1
2. Equipment and Materials .....	6-1
3. Procedure .....	6-1
A. CMC or CFDS .....	6-1
B. TCAS Display System .....	6-1
C. TCAS Aural and VSI/TRA Annunciations .....	6-3
D. TCAS Test Menu and System Status Pages .....	6-6
(1) TCAS Test Menu .....	6-6
(2) System Status Page .....	6-7
(3) Display Status Page .....	6-8
(4) RAD/ALT Status Page .....	6-9
(5) Transponder (XPDR) Status Page .....	6-10
(6) Programming Pins Status Pages .....	6-11
(7) Help Reference Page .....	6-16
(8) Suppression Bus Fail Page .....	6-17



SYSTEM DESCRIPTION AND INSTALLATION MANUAL
TCAS 3000 Traffic Alert and Collision Avoidance System

Section Page
(9) Suppression Bus Clear Page 6-18
(10) Antenna Port Status Page 6-18
(11) Option Pins Status Page 6-19
(12) Part Numbers Page 6-20
E. TCAS Computer Unit Self-Test 6-20
F. Directional Antenna Test / Fault Isolation Procedure 6-23
MAINTENANCE PRACTICES 7-1
1. General 7-1
2. Equipment and Materials 7-1
3. Procedure for the RT-950/951 TCAS Computer Unit 7-2
A. Removal and Installation Procedure 7-2
B. Adjustment Procedure 7-2
C. Repair Procedure 7-2
D. Return to Service Procedures 7-2
4. Procedure for the Directional Antenna 7-3
A. Removal and Installation Procedure 7-3
B. Adjustment Procedure 7-4
C. Repair Procedure 7-4
D. Return to Service Procedures 7-4
5. Procedure for the Omnidirectional Antenna 7-4
A. Removal and Installation Procedure 7-4
B. Adjustment Procedure 7-5
C. Repair Procedure 7-5
D. Return to Service Procedures 7-5
6. Procedure for the Control Panel 7-5
A. Removal and Installation Procedure 7-5
B. Adjustment Procedure 7-5
C. Repair Procedure 7-5
D. Return to Service Procedures 7-5
7. Procedure for the VSI/TRA Display 7-6
A. Removal and Installation Procedure 7-6
B. Adjustment Procedure 7-6





**SYSTEM DESCRIPTION AND INSTALLATION MANUAL**  
TCAS 3000 Traffic Alert and Collision Avoidance System

<b>Section</b>	<b>Page</b>
C. Repair Procedure .....	7-6
D. Return to Service Procedures .....	7-6
8. Procedure for the Pressure Transducer Module .....	7-7
A. Removal and Installation Procedure .....	7-7
B. Adjustment Procedure .....	7-7
C. Repair Procedure .....	7-7
D. Return to Service Procedures .....	7-7
9. Procedure for the Transponder .....	7-8
A. Removal and Installation Procedure .....	7-8
B. Adjustment Procedure .....	7-8
C. Repair Procedure .....	7-8
D. Return to Service Procedures .....	7-9
10. Instructions for Continued Airworthiness, FAR Part 25.1529 .....	7-10
<b>INSPECTION/CHECK .....</b>	<b>8-1</b>
1. General .....	8-1
2. Equipment and Materials .....	8-1
3. Procedure .....	8-1
A. Check TCAS Computer Unit .....	8-1
B. Check Antennas .....	8-1
C. Check Control Panel .....	8-1
D. Check VSI/TRA Display .....	8-2
E. Check Transponders .....	8-2
<b>CLEANING/PAINTING .....</b>	<b>9-1</b>
1. General .....	9-1
2. Equipment and Materials .....	9-1
3. Cleaning .....	9-2
A. Clean TCAS Computer Unit and Mounting Tray .....	9-2
B. Clean Antennas .....	9-2
C. Clean Control Panel .....	9-2
D. Clean VSI/TRA Display .....	9-3
E. Clean Transponders .....	9-3
4. Painting .....	9-2



# SYSTEM DESCRIPTION AND INSTALLATION MANUAL

TCAS 3000 Traffic Alert and Collision Avoidance System

A. TCAS Directional Antennas .....	9-3
(1) Scope .....	9-3
(2) Procedure .....	9-3
(3) Performance Verification Testing .....	9-4
B. Other TCAS System LRUs .....	9-5
<b>REPAIRS</b> .....	<b>10-1</b>
1. General .....	10-1

## List of Illustrations

<b>Figure</b>		<b>Page</b>
Figure 1-1.	TCAS II Advisory Capabilities .....	1-8
Figure 1-2.	TCAS/Mode S Communication .....	1-9
Figure 1-3.	TA/RA Airspace Coverage .....	1-10
Figure 1-4.	Basic TCAS II Installation .....	1-11
Figure 1-5.	Typical System Configurations .....	1-12
Figure 1-6.	TCAS 3000 System Block Diagram .....	1-15
Figure 1-7.	RT-950 TCAS Computer Unit .....	1-17
Figure 1-8.	RT-951 TCAS Computer Unit .....	1-18
Figure 1-9.	Directional Antenna .....	1-27
Figure 1-10.	ACSS Control Panels .....	1-28
Figure 1-11.	Typical Gables ATC/TCAS Control Panel .....	1-31
Figure 1-12.	Typical VSI/TRA Display Formats .....	1-35
Figure 1-13.	VSI/TRA Interface Diagram (41-Pin Version) .....	1-38
Figure 1-14.	VSI/TRA Interface Diagram (55-Pin Version) .....	1-39
Figure 1-15.	Pressure Transducer Module .....	1-40
Figure 1-16.	XS-950 Data Link Transponder .....	1-42
Figure 1-17.	RCZ-852 Diversity Mode S Transponder .....	1-47
Figure 1-18.	TCAS II Display Test Pattern .....	1-59
Figure 2-1.	RT-950 TCAS Computer Unit Outline and Installation Drawing .....	2-7
Figure 2-2.	RT-951 TCAS Computer Unit Outline and Installation Diagram .....	2-11
Figure 2-3.	RT-951 TCAS Computer Unit Outline and Installation Diagram .....	2-15
Figure 2-4.	TCAS Directional and Omnidirectional Antenna Locations .....	2-19
Figure 2-5.	Directional Antenna Angular Orientation .....	2-20
Figure 2-6.	Directional Antenna Outline and Installation Diagram .....	2-21



**SYSTEM DESCRIPTION AND INSTALLATION MANUAL**  
TCAS 3000 Traffic Alert and Collision Avoidance System

**List of Illustrations (cont)**

<b>Figure</b>		<b>Page</b>
Figure 2-7.	Directional Antenna Baseplate Outline and Installation Diagram . . . . .	2-31
Figure 2-8.	Control Panel (Dual Mode S) Outline and Installation Diagram . . . . .	2-35
Figure 2-9.	Control Panel (ATCRBS-Mode S) Outline and Installation Diagram . . . . .	2-37
Figure 2-10.	Gables G7130-XX Control Panel Outline and Installation Diagram . . . . .	2-39
Figure 2-11.	VSI/TRA Outline and Installation Diagram . . . . .	2-41
Figure 2-12.	Pressure Transducer Module Outline and Installation Diagram . . . . .	2-43
Figure 2-13.	XS-950 Data Link Transponder Outline and Installation Diagram . . . . .	2-49
Figure 2-14.	RCZ-852 Mode S Transponder Outline and Installation Diagram . . . . .	2-53
Figure 3-1.	Typical Installation Types . . . . .	3-2
Figure 3-2.	TCAS System Interconnect Diagram . . . . .	3-3
Figure 3-3.	TCAS Computer Unit ARINC 600 Connector (P1) Layout . . . . .	3-17
Figure 3-4.	Contact Arrangement for CU Left Top Plug (LTP) Insert . . . . .	3-18
Figure 3-5.	Contact Arrangement for CU Left Middle Plug (LMP) Insert . . . . .	3-18
Figure 3-6.	Contact Arrangement for Left Bottom Plug (LBP) Insert . . . . .	3-19
Figure 3-7.	Contact Arrangement for Right Middle Plug (RMP) Insert . . . . .	3-20
Figure 3-8.	Contact Arrangement for Right Bottom Plug (RBP) Insert . . . . .	3-21
Figure 3-9.	TCAS Computer Unit Data Loader Connector (J1) Pin Layout . . . . .	3-22
Figure 3-10.	VSI/TRA 41-Pin Connector Layout . . . . .	3-34
Figure 3-11.	VSI/TRA 55-Pin Connector Layout . . . . .	3-38
Figure 3-12.	Strap Assembly . . . . .	3-55
Figure 5-1.	VSI/TRA Fault Warning Display . . . . .	5-3
Figure 5-2.	Compact Flash Card Access Port and LRU Identification Label . . . . .	5-8
Figure 5-3.	Compact Flash Card Ejector Location . . . . .	5-9
Figure 5-4.	RS-232 PC to TCAS Interface Cable . . . . .	5-12
Figure 6-1.	TCAS Test Menu Page . . . . .	6-6
Figure 6-2.	Typical System Status Page . . . . .	6-7
Figure 6-3.	Typical Display Status Page . . . . .	6-8
Figure 6-4.	Typical RAD/ALT Status Page . . . . .	6-9
Figure 6-5.	Typical Transponder (XPDR) Status Page . . . . .	6-10
Figure 6-6.	Typical Program Pins 1/3 Page . . . . .	6-11
Figure 6-7.	Typical Program Pins 2/3 Page . . . . .	6-13
Figure 6-8.	Typical Program Pins 3/3 Page . . . . .	6-14



**SYSTEM DESCRIPTION AND INSTALLATION MANUAL**

TCAS 3000 Traffic Alert and Collision Avoidance System

**List of Illustrations (cont)**

<b>Figure</b>		<b>Page</b>
Figure 6-9.	Help Reference Page .....	6-16
Figure 6-10.	Suppression Bus Fail Page .....	6-17
Figure 6-11.	Suppression Bus Clear Page .....	6-18
Figure 6-12.	Typical Antenna Port Status Page .....	6-18
Figure 6-13.	Typical Option Pins Status Page .....	6-19
Figure 6-14.	Typical Option Pins Status Page .....	6-20



**SYSTEM DESCRIPTION AND INSTALLATION MANUAL**  
 TCAS 3000 Traffic Alert and Collision Avoidance System

**List of Tables**

<b><u>Table</u></b>		<b><u>Page</u></b>
Acronyms and Abbreviations Table	.....	INTRO-2
Table 1-1.	System Components Supplied by ACSS .....	1-2
Table 1-2.	System Components Not Supplied by ACSS .....	1-3
Table 1-3.	Directional Antenna Configurations .....	1-3
Table 1-4.	Control Panel Configurations .....	1-5
Table 1-5.	VSI/TRA Display Configurations .....	1-6
Table 1-6.	RT-950/951 TCAS Computer Unit Leading Particulars .....	1-19
Table 1-7.	ACSS Control Panel Leading Particulars .....	1-29
Table 1-8.	Gables G7130 Series Control Panel Leading Particulars .....	1-31
Table 1-9.	VSI/TRA Leading Particulars .....	1-36
Table 1-10.	Pressure Transducer Module Leading Particulars .....	1-41
Table 1-11.	XS-950 Data Link Transponder Leading Particulars .....	1-43
Table 1-12.	RCZ-852 Diversity Mode S Transponder Leading Particulars .....	1-48
Table 1-13.	TCAS Traffic Symbols .....	1-53
Table 3-1.	ACSS Dual Mode S Control Panel Interconnect Data .....	3-23
Table 3-2.	ACSS ATCRBS-Mode S Control Panel Interconnect Data .....	3-26
Table 3-3.	Gables G7130-XX ATC/TCAS Control Panel Interconnect Data .....	3-29
Table 3-4.	41-Pin VSI/TRA Interconnect Data .....	3-31
Table 3-5.	55-Pin VSI/TRA Interconnect Data .....	3-35
Table 3-6.	Pressure Transducer Module Interconnect Data .....	3-39
Table 3-7.	XS-950 Data Link Transponder Interconnect Data .....	3-41
Table 3-8.	RCZ-852 Diversity Mode S Transponder Interconnect Data .....	3-49
Table 3-9.	Strap Assembly Strap Assignments .....	3-54
Table 3-10.	Strap Assembly Programming Instructions .....	3-55
Table 4-1.	RT-950/951 TCAS Computer Unit Loading/Gradient Specifications ..	4-2
Table 4-2.	ACSS Dual Mode S Control Panel Interface Descriptions .....	4-23
Table 4-3.	ACSS ATCRBS-Mode S Control Panel Interface Descriptions .....	4-25
Table 4-4.	Gables Control Panel Interface Descriptions .....	4-28
Table 4-5.	41-Pin VSI/TRA Interface Descriptions .....	4-31
Table 4-6.	55-Pin VSI/TRA Interface Descriptions .....	4-36
Table 4-7.	Pressure Transducer Module Interface Descriptions .....	4-42
Table 4-8.	XS-950 Data Link Transponder Interface Descriptions .....	4-43



## SYSTEM DESCRIPTION AND INSTALLATION MANUAL

TCAS 3000 Traffic Alert and Collision Avoidance System

### List of Tables (cont)

<b><u>Table</u></b>		<b><u>Page</u></b>
Table 4-9.	RCZ-852 Diversity Mode S Transponder Interface Descriptions . . . . .	4-52
Table 5-1.	Equipment and Materials . . . . .	5-1
Table 5-2.	Computer Unit Harness Checkout . . . . .	5-1
Table 5-3.	Extended Test Menu Selections . . . . .	5-5
Table 5-4.	Compact Flash Upload / LED Correlation . . . . .	5-9
Table 6-1.	TCAS Aural and VSI/TRA Annunciations . . . . .	6-3
Table 6-2.	System Status Page Fault Messages . . . . .	6-7
Table 6-3.	Computer Unit Self-Test Execution . . . . .	6-21
Table 6-4.	Computer Unit Fault Reporting and Corrective Actions . . . . .	6-22
Table 6-5.	Antenna Wiring Resistance . . . . .	6-23
Table 7-1.	Materials . . . . .	7-1
Table 9-1.	Equipment and Materials . . . . .	9-1
Table 10-1.	LRU Maintenance Manuals . . . . .	10-1



**SYSTEM DESCRIPTION AND INSTALLATION MANUAL**  
TCAS 3000 Traffic Alert and Collision Avoidance System

## **INTRODUCTION**

### **1. General**

This manual provides general system installation and maintenance instructions and theory of operation for the TCAS 3000 Traffic Alert and Collision Avoidance System. It also provides interface information and interconnect diagrams to permit a general understanding of the overall system.

The purpose of this manual is to help you install, operate, maintain and troubleshoot the TCAS 3000 Traffic Alert and Collision Avoidance System in the aircraft. Common system maintenance procedures are not presented in this manual. The best established shop and flight line practices should be used.

**NOTE:** The conditions and tests required for Technical Standard Order (TSO) approval of this article are minimum performance standards. It is the responsibility of those installing this article either on or within a specific type or class of aircraft to determine that the aircraft installation conditions are within the TSO standards. The article may be installed only if the installation is performed in accordance with the applicable airworthiness and production requirements.

### **2. Reference Documents**

Publications on subsystems installed as part of the TCAS 3000 Traffic Alert and Collision Avoidance System are identified in the list that follows:

<b>Document Title</b>	<b>ACSS Publication Number</b>
Mode S Data Link Transponder System Description and Installation Manual	A09-3839-001
PRIMUS II SRZ-85X Series Integrated Radio System Operation and Installation Manual (Used if transponders or control panel is part of PRIMUS II Integrated Radio System)	A15-3800-001 (Honeywell)
Handling, Storage, and Shipping Procedures Instruction Manual for ACSS Avionics Equipment	A09-1100-001

### **3. Weights and Measurements**

Weights and measurements in this manual use both U.S. and S.I. (metric) values.

### **4. Acronyms and Abbreviations**

The letter symbols for abbreviations are the same as shown in ANSI/IEEE Std 260 and ASME Y1.1, except as identified in the acronyms and abbreviations table.



**SYSTEM DESCRIPTION AND INSTALLATION MANUAL**  
TCAS 3000 Traffic Alert and Collision Avoidance System

**Acronyms and Abbreviations Table**

<b>Term</b>	<b>Definition</b>
ac	alternating current
ADC	air data computer
ADL	airborne data loader
ADLP	airborne data link processor
ADS-B	automatic dependent surveillance broadcast
AGL	above ground level
ALT	altitude
AMM	aircraft maintenance manual
AMN	ACSS Material Number
ANT	antenna
ATC	air traffic control
ATCRBS	air traffic control radar beacon system
ATN	Aircraft Telecommunications Network
BITE	built-in test equipment
BOT	bottom
CAS	collision avoidance system
CFDIU	centralized fault display interface unit
CFDS	central fault display system
CMC	central maintenance computer
CMM	component maintenance manual
COMM	communication
CU	computer unit
DADC	digital air data computer
dc	direct current
DISP	display
DLP	data link processor
EFIS	electronic flight instrument system
ELM	extended length message
EPROM	erasable programmable read-only memory
FAA	Federal Aviation Administration
FPM	feet per minute





**SYSTEM DESCRIPTION AND INSTALLATION MANUAL**  
TCAS 3000 Traffic Alert and Collision Avoidance System

**Acronyms and Abbreviations Table (cont)**

<b>Term</b>	<b>Definition</b>
HDG	heading
I/O	input/output
INH	inhibit
IPC	illustrated parts catalog
IRS	inertial reference system
LBP	left bottom plug
LCD	liquid crystal display
LMP	left middle plug
LRU	line replaceable unit
LTP	left top plug
MCU	modular concept unit
MEL	minimum equipment list
Mode S	mode select transponder
MTBF	mean time between failures
MTL	minimum trigger level
PDL	portable data loader
PMS	performance management system
POST	power-on self-test
PROG	program
PTM	pressure transducer module
RA	resolution advisory
RAD ALT	radio altimeter
RBP	right bottom plug
RCB	radio communication bus
RMP	right middle plug
RMU	radio management unit
RNG	range
RTP	right top plug
SPI	special pulse identifier
SSM	sign status matrix



**SYSTEM DESCRIPTION AND INSTALLATION MANUAL**  
TCAS 3000 Traffic Alert and Collision Avoidance System

**Acronyms and Abbreviations Table (cont)**

<b>Term</b>	<b>Definition</b>
STBY	standby
TA	traffic advisory
TCAS	traffic alert and collision avoidance system
TRA	traffic resolution advisory
TSO	Technical Standard Order
VSI	vertical speed indicator
VSWR	voltage standing wave ratio
WOW	weight-on-wheels
XPDR/XPNDR	transponder



**SYSTEM DESCRIPTION AND INSTALLATION MANUAL**  
TCAS 3000 Traffic Alert and Collision Avoidance System

## 5. Special Precautions

Warnings, cautions, and notes in this manual give the data that follows:

- A **WARNING** is an operation or maintenance procedure or condition, which, if not obeyed, can cause injury or death
- A **CAUTION** is an operation or maintenance procedure or condition, which, if not obeyed, can cause damage to the equipment
- A **NOTE** gives data to make the work easier or gives directions to go to a procedure.

All personnel who operate and do maintenance on the TCAS components and on the applicable test equipment, must know and obey the safety precautions. The warnings and cautions that follow apply to all parts of this manual.

**WARNING: HIGH VOLTAGES MAY BE PRESENT ON SYSTEM INTERCONNECT CABLES. MAKE SURE THAT SYSTEM POWER IS OFF BEFORE YOU DISCONNECT LRU MATING CONNECTORS.**

**CAUTION: ACSS HAS PREPARED AN AIRWORTHINESS CRITICAL REQUIREMENTS ANALYSIS FOR THIS AIRBORNE EQUIPMENT TO MAKE SURE THAT IT WILL NOT CAUSE A DANGEROUS IN-FLIGHT CONDITION. SPECIFIC PARTS, TESTS, AND PROCEDURES THAT ARE IDENTIFIED AS *INSTALLATION* CRITICAL IN THE ANALYSIS ARE CHANGED TO AIRWORTHINESS CRITICAL IN THIS MANUAL. IT IS NECESSARY TO DO THESE PROCEDURES AND TESTS TO GET THE APPROVED RESULTS.**

**CAUTION: THE TCAS 3000 SYSTEM CONTAINS LRUS THAT ARE ELECTROSTATIC DISCHARGE SENSITIVE (ESDS). IF YOU DO NOT OBEY THE NECESSARY CONTROLS, A FAILURE OR UNSATISFACTORY OPERATION OF THE UNIT CAN OCCUR FROM ELECTROSTATIC DISCHARGE. USE APPROVED INDUSTRY PRECAUTIONS TO KEEP THE RISK OF DAMAGE TO A MINIMUM WHEN YOU TOUCH, REMOVE, OR INSTALL LRUS.**



**SYSTEM DESCRIPTION AND INSTALLATION MANUAL**  
TCAS 3000 Traffic Alert and Collision Avoidance System

Blank Page



**SYSTEM DESCRIPTION AND INSTALLATION MANUAL**  
TCAS 3000 Traffic Alert and Collision Avoidance System

**SYSTEM DESCRIPTION**

**1. General**

The purpose of the TCAS 3000 Traffic Alert and Collision Avoidance System is to determine the range, altitude, and bearing of other aircraft equipped with Mode S/Air Traffic Control Radar Beacon System (ATCRBS) transponders, with respect to the location of own aircraft. It also monitors the trajectory of these aircraft for the purpose of determining if any of them constitute a potential collision hazard. The TCAS is responsible for estimating the projected intruder track and determining if a potential conflict exists. If so, the system displays an advisory to the pilot. The system also provides guidance for the optimum vertical avoidance maneuver. Complementary avoidance maneuvers between two TCAS equipped aircraft are ensured by coordination of mutual intentions with the other aircraft through the Mode S transponders.

**2. System Components**

Table 1-1 gives the components that are supplied by ACSS. Table 1-2 gives the components that are necessary, but are not supplied by ACSS.

Table 1-3 thru Table 1-5 provide additional component descriptions as follows:

- Table 1-3. Directional Antenna Configurations
- Table 1-4. Control Panel Configurations
- Table 1-5. VSI/TRA Display Configurations.



**SYSTEM DESCRIPTION AND INSTALLATION MANUAL**  
 TCAS 3000 Traffic Alert and Collision Avoidance System

**Table 1-1. System Components Supplied by ACSS**

Component	Model No.	ACSS Part No.
TCAS Computer Unit (6-MCU size unit)	----	9003000-10yyy (Note 1.)
TCAS Computer Unit (4-MCU size unit)	----	9003000-55yyy, -65yyy (Note 1.)
Directional Antenna (See Table 1-3 for configuration descriptions)	--	7514081-VAR or 7514060-VAR
Control Panel (See Table 1-4 for configuration descriptions)	--	4052190-VAR
VSI/TRA Display (See Table 1-5 for configuration descriptions)	--	4067241-VAR
Pressure Transducer Module (PTM)	--	4067487-901 (Note 2.)
PTM Mounting Bracket, Right Angle	--	4067487-901
PTM Mounting Plate, 3-ATI Panel Mount	--	4067492-VAR (Note 3.)
Mode S Data Link Transponder (4-MCU size unit)	XS-950	7517800-xyyyy
Diversity Mode S Transponder	RCZ-852	7510700-850/-951
Installation Kit for RCZ-852 Mode S Transponder (Contains mounting tray, 106 pin ARINC 404 mating connector and two TNC RF jack connectors)	IK-415	7510707-968
<b>NOTES:</b>		
<ol style="list-style-type: none"> <li>1. The last three digits of the five digit dash number (yyy) correspond to the unit software version.</li> <li>2. The PTM is only required on installations that use a ACSS VSI/TRA display where no electrical vertical speed data in a compatible format is available.</li> <li>3. The 3-ATI panel mount comes in three different color options: -901 (gray), -902 (brown), and -903 (black).</li> </ol>		



**SYSTEM DESCRIPTION AND INSTALLATION MANUAL**  
TCAS 3000 Traffic Alert and Collision Avoidance System

**Table 1–2. System Components Not Supplied by ACSS**

Component	Comments
Gables G7130 Series ATC/TCAS Dual Transponder Control Panel (Note 1.)	General aviation type controller that operates from 28 V dc aircraft power (Note 2.)
Gables G6990, G6991, G6992, G6993, and 7490 Series Mode S/TCAS Control Panels (Note 1.)	Commercial aviation type controllers that operate from 115 V ac aircraft power (Note 2.)
Omnidirectional TCAS Antenna (Note 3.)	ATC blade antenna, dc shorted, TSO C119a compliant, 1030 to 1090 MHz. Installer to supply antenna.
Omnidirectional ATC Antennas (Note 4.)	ATC blade antenna, dc shorted, TSO C112 compliant, 1030 to 1090 MHz. Installer to supply antenna.
Mounting Tray, TCAS Computer (6–MCU size unit)	ARINC 600 6–MCU Mount, cooling air required. Installer to supply mount.
Mounting Tray, TCAS Computer (4–MCU size unit)	ARINC 600 4–MCU Mount, no cooling air required. Installer to supply mount.
Mounting Tray, Data Link Transponder (4–MCU size unit)	ARINC 600 4–MCU Mount, cooling air recommended but not required. Installer to supply mount.
<b>NOTES:</b>	
<ol style="list-style-type: none"> <li>1. Refer to Table 1–4 for individual part number descriptions.</li> <li>2. For additional information, pricing and availability contact: Gables Engineering, Inc. 247 Greco Avenue, Coral Gables, Florida 33146 Telephone (305) 774–4400 Fax (305) 774–4465</li> <li>3. A bottom omnidirectional antenna can be used as an optional replacement for the directional antenna.</li> <li>4. A diversity transponder installation requires both a top and bottom ATC antenna.</li> </ol>	

**Table 1–3. Directional Antenna Configurations**

Antenna Part Number	Description
7514081–901	Directional antenna with flat base, four hole mounting pattern, and 1.560–inch connector extension length
7514081–902	Directional antenna with flat base, eight hole mounting pattern, and 1.560–inch connector extension length
7514081–903	Directional antenna with a curved 61.52–inch radius base, eight hole mounting pattern, and 1.560–inch connector extension length
7514081–904	Directional antenna with a curved 66.52–inch radius base, eight hole mounting pattern, and 1.560–inch connector extension length



**SYSTEM DESCRIPTION AND INSTALLATION MANUAL**  
 TCAS 3000 Traffic Alert and Collision Avoidance System

**Table 1–3. Directional Antenna Configurations (cont)**

<b>Antenna Part Number</b>	<b>Description</b>
7514081–905	Directional antenna with a curved 74.02–inch radius base, eight hole mounting pattern, and 1.560–inch connector extension length
7514081–906	Directional antenna with a curved 77.78–inch radius base, eight hole mounting pattern, and 1.560–inch connector extension length
7514081–907	Directional antenna with a curved 99.02–inch radius base, eight hole mounting pattern, and 1.560–inch connector extension length
7514081–908	Directional antenna with a curved 111.02–inch radius base, four hole mounting pattern, and 1.560–inch connector extension length
7514081–909	Directional antenna with a curved 118.52–inch radius base, eight hole mounting pattern, and 1.560–inch connector extension length
7514081–910	Directional antenna with a flat base, eight hole mounting pattern, and 0.705–inch connector extension length
7514081–911	Directional antenna with a curved 77.78–inch radius base, eight hole mounting pattern, special 0.015–inch Teflon gasket, and 1.560–inch connector extension length
7514081–912	Directional antenna with a curved 111.02–inch radius base, eight hole mounting pattern, special 0.015–inch Teflon gasket, and 1.560–inch connector extension length
7514081–913	Directional antenna with a flat base, four hole mounting pattern, and 0.705–inch connector extension length
7514081–914	Directional antenna with a curved 53.02–inch radius base, eight hole mounting pattern, and 0.705–inch connector extension length
7514081–915	Directional antenna with a curved 44.80–inch radius base, eight hole mounting pattern, and 0.705–inch connector extension length
7514081–916	Directional antenna with a curved 42.00–inch radius base, eight hole mounting pattern, and 0.705–inch connector extension length
7514081–917	Directional antenna with a curved 85.06–inch radius base, eight hole mounting pattern, and 1.560–inch connector extension length
7514060–901	Directional antenna with no adapter plate and 1.560–inch connector extension length. Installer must supply adapter plate to mate with aircraft fuselage.
7514060–902	Directional antenna with no adapter plate and 0.705–inch connector extension length. Installer must supply adapter plate to mate with aircraft fuselage.





**SYSTEM DESCRIPTION AND INSTALLATION MANUAL**  
TCAS 3000 Traffic Alert and Collision Avoidance System

**Table 1-4. Control Panel Configurations**

<b>Control Panel Part Number</b>	<b>Description</b>
4052190-902	Control Panel, Dual Mode S/TCAS, Brown Bezel
4052190-903	Control Panel, Single Mode S-Single ATCRBS/TCAS, Brown Bezel
4052190-904	Control Panel, Dual Mode S/TCAS, Gray Bezel
4052190-905	Control Panel, Single Mode S-Single ATCRBS/TCAS, Gray Bezel
4052190-906	Control Panel, Dual Mode S/TCAS, Black Bezel
4052190-907	Control Panel, Single Mode S-Single ATCRBS/TCAS, Black Bezel
4052190-908	Control Panel, Dual Mode S/TCAS, Dark Gray Bezel
4052190-909	Control Panel, Single Mode S-Single ATCRBS/TCAS, Dark Gray Bezel
<b>Gables Control Panels</b>	
Gables G7130-02	Control Panel, Dual Mode S/TCAS, Rotary knob 4096 code entry, Black Bezel, Operates from +28 V dc aircraft power
Gables G7130-05	Control Panel, Dual Mode S/TCAS, Rotary knob 4096 code entry, Gray Bezel, Operates from +28 V dc aircraft power
Gables G7130-06	Control Panel, Dual Mode S/TCAS, Rotary knob 4096 code entry, Black Bezel, Extended Range (80, 120 Mi), Operates from +28 V dc aircraft power
Gables G7130-07	Control Panel, Dual Mode S/TCAS, Rotary knob 4096 code entry, Gray Bezel, Extended Range (80, 120 Mi), Operates from +28 V dc aircraft power
Gables G6990-XX	Control Panel, Dual Mode S/TCAS, Pushbutton 4096 code entry, Operates from 115 V ac aircraft power
Gables G6991-XX	Control Panel, Single Mode S-Single ATCRBS/TCAS, Pushbutton 4096 code entry, Operates from 115 V ac aircraft power
Gables G6992-XX	Control Panel, Dual Mode S/TCAS, Rotary knob 4096 code entry, Operates from 115 V ac aircraft power
Gables G6993-XX	Control Panel, Single Mode S-Single ATCRBS/TCAS, Rotary knob 4096 code entry, Operates from 115 V ac aircraft power
Gables G7490-XX	Control Panel, Dual Mode S/TCAS, Push Button 4096 code entry, Operates from 115 V ac aircraft power



**SYSTEM DESCRIPTION AND INSTALLATION MANUAL**  
 TCAS 3000 Traffic Alert and Collision Avoidance System

**Table 1-5. VSI/TRA Display Configurations**

<b>VSI/TRA Part Number</b>	<b>Description</b>
4067241-84X  -840 -841 -842 -843 -844 -845	The VSI/TRA Display provides continuous TCAS symbology and non-ARINC display control features: 6, 14, 40 mile ranges and above/normal/below display volumes. It has pin programmable altitude band, range, lighting curve, and VSI source selection.  Gray bezel, 55-pin connector (contains bootstrap function) Black bezel, 55-pin connector (contains bootstrap function) Brown bezel, 55-pin connector (contains bootstrap function) Gray bezel, 41-pin connector Black bezel, 41-pin connector Brown bezel, 41-pin connector
4067241-86X  -860 -861 -862 -863 -864 -865	This VSI/TRA Display provides a single range default (6.0 miles), continuous or "POP-UP" TCAS symbology, and a test mode display. ARINC display control features include: 6, 12, 14, 20, and 40 mile ranges and above/normal/below display volumes. It has pin programmable VSI source selection, lighting curve, format mode, and traffic filter.  Gray bezel, 41-pin connector Black bezel, 41-pin connector Brown bezel, 41-pin connector Gray bezel, 55-pin connector (contains bootstrap function) Black bezel, 55-pin connector (contains bootstrap function) Brown bezel, 55-pin connector (contains bootstrap function)
4067241-88X  -880 -881 -882 -883 -884 -885	This VSI/TRA Display provides a single range default (6.0 miles), continuous or "POP-UP" TCAS symbology, and a test mode display. ARINC display control features include: 6, 12, 14, 20, and 40 mile ranges and above/normal/below display volumes. It has pin programmable VSI source selection, lighting curve, format mode, traffic filter, and a 1.6, 3.2, 5.0, or 6.4 second time constants.  Gray bezel, 41-pin connector Black bezel, 41-pin connector Brown bezel, 41-pin connector Gray bezel, 55-pin connector (contains bootstrap function) Black bezel, 55-pin connector (contains bootstrap function) Brown bezel, 55-pin connector (contains bootstrap function)
4067241-89X  -890 -891 -892 -893 -894 -895	This VSI/TRA Display provides a single range default (6.0 miles), continuous or "POP-UP" TCAS symbology, and a test mode display. ARINC display control features include: 6, 12, 14, 20, and 40 mile ranges and above/normal/below display volumes. It has pin programmable VSI display (English/Metric) VSI source selection, format mode, traffic filter, and a 1.6, 3.2, 5.0, or 6.4 second time constants.  Gray bezel, 41-pin connector Black bezel, 41-pin connector Brown bezel, 41-pin connector Gray bezel, 55-pin connector (contains bootstrap function) Black bezel, 55-pin connector (contains bootstrap function) Brown bezel, 55-pin connector (contains bootstrap function)



## SYSTEM DESCRIPTION AND INSTALLATION MANUAL

### TCAS 3000 Traffic Alert and Collision Avoidance System

### 3. System Description

The TCAS 3000 is an onboard advisory system designed to act as a backup to the air traffic control (ATC) radar and the “see and avoid” procedures. By computing the closure rate and altitude of all transponder equipped aircraft in the surrounding airspace, the TCAS can anticipate a potential midair collision before it has a chance to materialize.

TCAS 3000 continually plots local air traffic on the associated display, and in the event of a conflicting flightpath, guides the pilot towards the correct avoidance maneuver. If the intruding aircraft is also equipped with a TCAS II compatible system, the two systems can communicate their mutual intentions through the Mode S transponders. The coordinated advisories that result allow the two pilots to execute complementary avoidance maneuvers.

TCAS 3000 complies with ARINC Characteristic 735A and TSO-C119-b.

#### A. System Functional Description

Vertical guidance to avoid midair collisions is accomplished by interrogating the Mode A, Mode C, and Mode S transponders of potential threat aircraft, tracking their responses, and providing advisories to the flight crew to assure vertical separation. Two levels of advisories are provided:

- Traffic advisories (TA), indicate the range, bearing, and relative altitude of the intruder to aid in visual acquisition of the intruder
- Resolution advisories (RA) indicate a vertical maneuver to be performed or avoided in order to assure safe separation.

Traffic advisories can be displayed on ACSS Vertical Speed Indicator/Traffic and Resolution Advisory (VSI/TRA) display, Electronic Flight Instrument System (EFIS) or any instrument that displays the appropriate symbology and conforms to the definition of ARINC Characteristic 735.

Resolution advisories can be displayed on the ACSS VSI/TRA display, EFIS or any other indicator that displays the appropriate symbology and conforms to the definition of ARINC Characteristic 735.

Figure 1-1 shows the various types of intruder equipment and the resulting advisories. It should be noted that Mode A equipped intruders result in detection and display of TAs only. An intruder not equipped with a transponder is invisible to TCAS.

Communication with another TCAS equipped aircraft is provided by an onboard diversity Mode S transponder. Only one onboard Mode S transponder is required for TCAS operation. However, the ACSS TCAS 3000 operates with either of two onboard Mode S transponders, one of which operates as a spare. The transponder in use is selectable from the cockpit. Figure 1-2 shows the communication between two TCAS equipped aircraft.



**SYSTEM DESCRIPTION AND INSTALLATION MANUAL**  
TCAS 3000 Traffic Alert and Collision Avoidance System

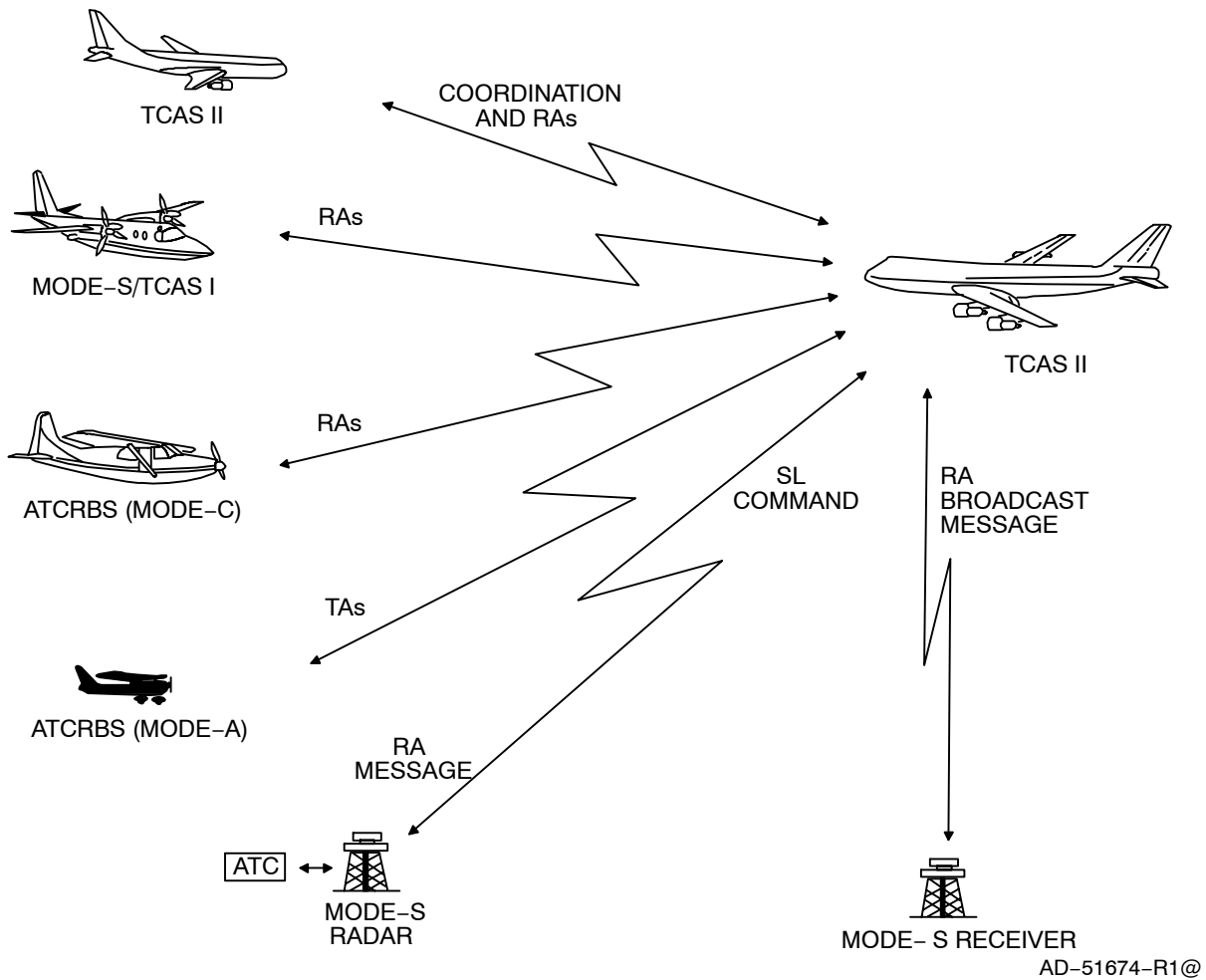
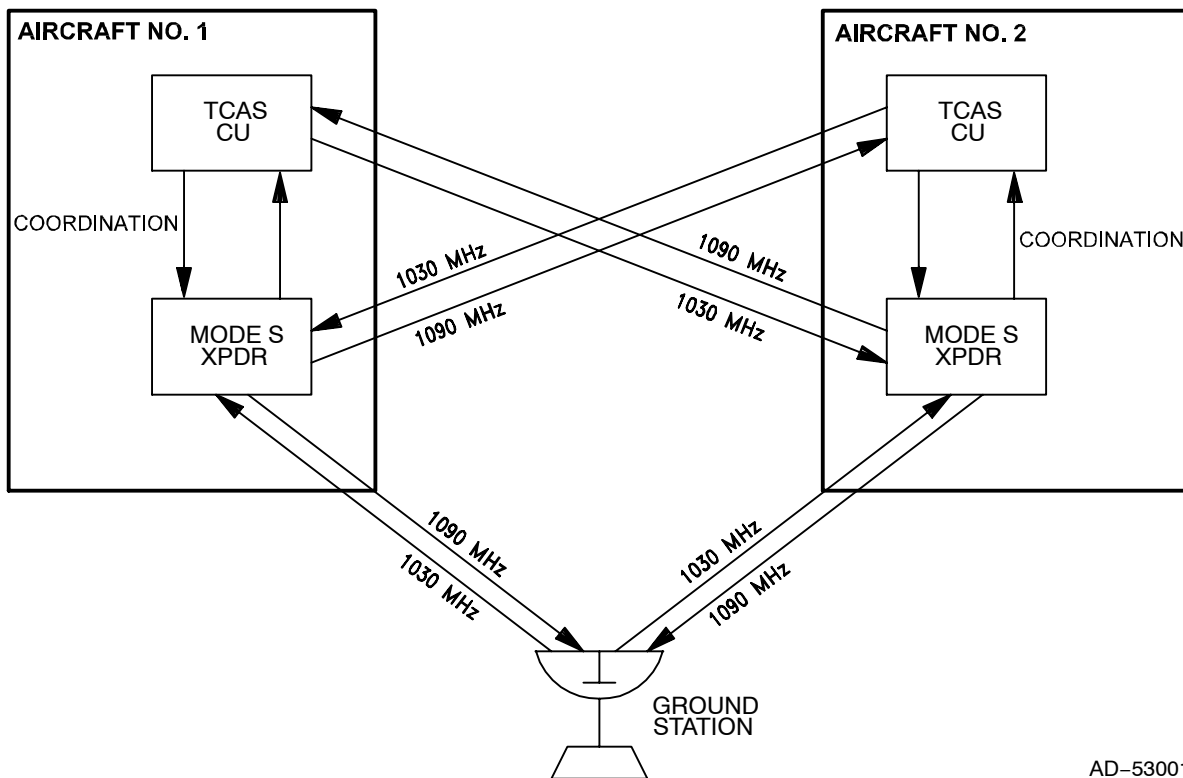

**Figure 1-1. TCAS II Advisory Capabilities**



## SYSTEM DESCRIPTION AND INSTALLATION MANUAL

### TCAS 3000 Traffic Alert and Collision Avoidance System



AD-53001@

**Figure 1-2. TCAS/Mode S Communication**

The TCAS 3000 generates both RAs and TAs when the TA/RA mode is selected. The two types of advisories correspond to time-based protection zones around the aircraft. The airspace around the TCAS aircraft where an RA is annunciated represents the warning area, while the larger airspace which results in a TA being annunciated is the caution area. Figure 1-3 contrasts the airspace covered by the two types of advisories.

The onboard equipment listed below must be linked to the TCAS 3000 as shown in Figure 1-4.

- Mode S transponder with associated antennas
- Radio altimeter
- Air Data Computer (ADC) (digital or analog). If an ADC does not support vertical speed rate data, an optional PTM must be used if the display is a ACSS VSI/TRA.
- ATC/TCAS control panel. A separate control panel is not the only method of control for the TCAS. Other components, such as a Honeywell Radio Management Unit (RMU) as part of a Primus II Integrated Radio System, can be used.
- Omnidirectional antenna. The TCAS 3000 accepts two types of bottom antennas: A standard directional antenna or an optional ATC-type omnidirectional antenna. If an omnidirectional antenna is installed, it must be supplied by the installer. If a directional antenna is installed at both top and bottom antenna locations, a bottom omnidirectional antenna is not needed.



**SYSTEM DESCRIPTION AND INSTALLATION MANUAL**  
TCAS 3000 Traffic Alert and Collision Avoidance System

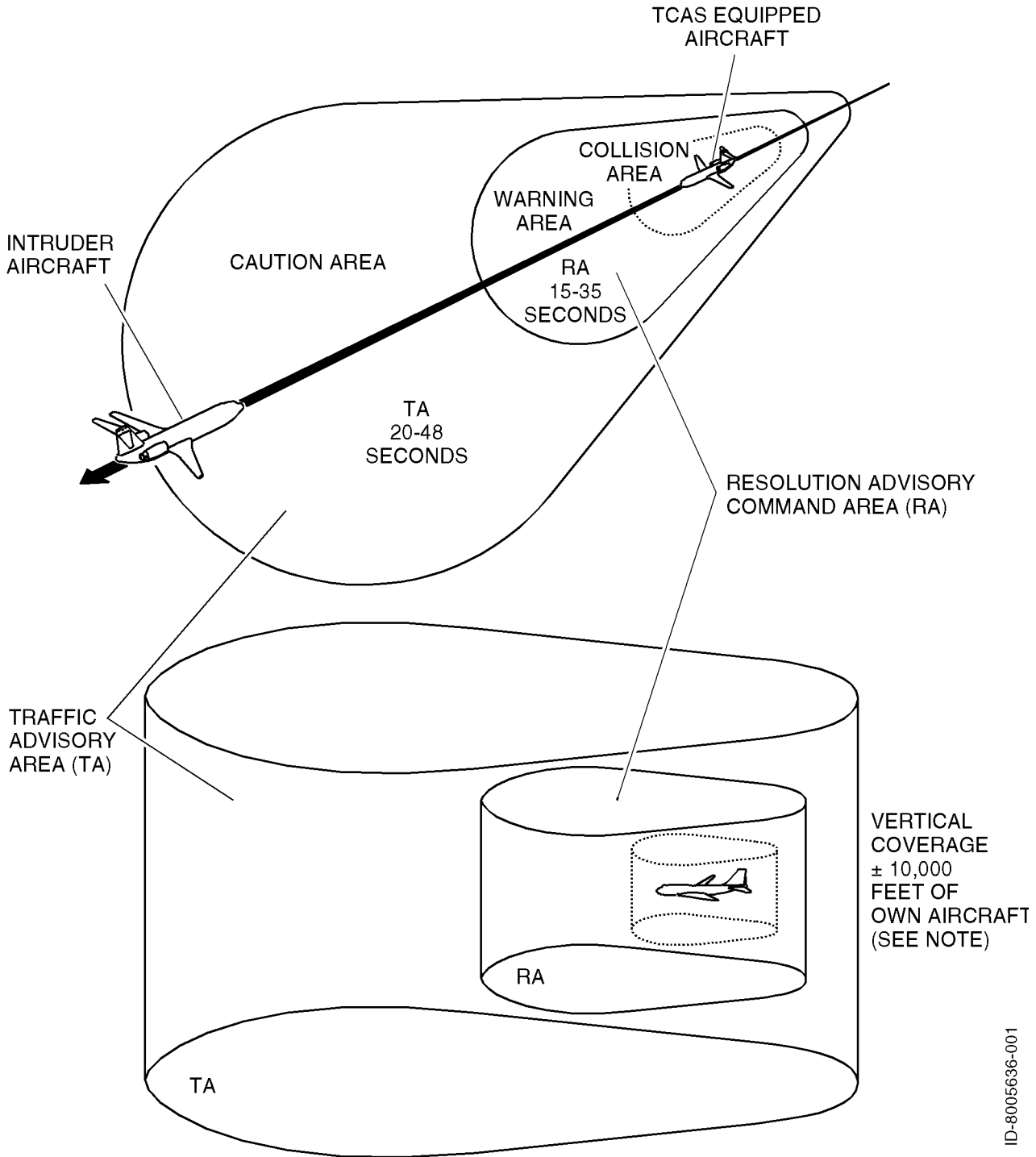

**Figure 1-3. TA/RA Airspace Coverage**

ID-8005636-001



## SYSTEM DESCRIPTION AND INSTALLATION MANUAL

### TCAS 3000 Traffic Alert and Collision Avoidance System

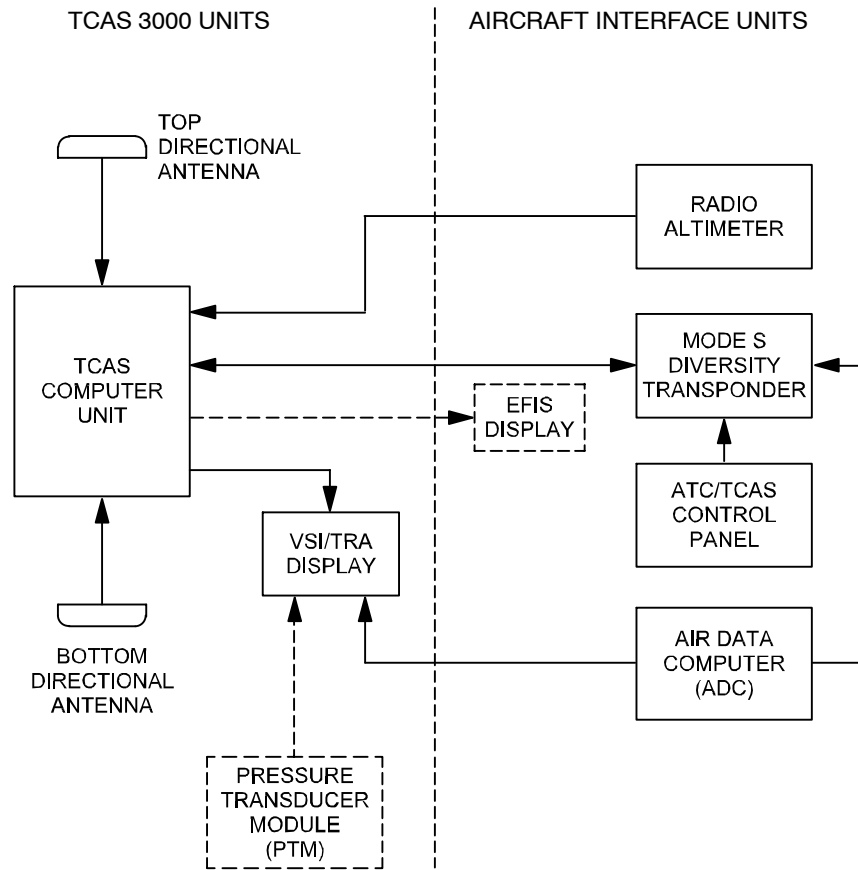

NOTE: DASHED BOXES / LINES DENOTE OPTIONAL ALTERNATE COMPONENTS. THE PTM IS AN ALTERNATE FOR THE ADC AND THE EFIS IS AN ALTERNATE FOR THE VSI/TRA.

AD-31666-R2@

**Figure 1-4. Basic TCAS II Installation**

### B. System Configurations

The TCAS 3000 may be installed in several different configurations depending on the transponders used and the choice of antennas and displays. Some typical configurations are shown in Figure 1-5. Other combinations are feasible. Figure 1-6 shows the signals and overall interconnects for a typical TCAS 3000 installation with dual transponders.

- Configuration A shows the TCAS linked to dual Mode S transponders. The system operates with either transponder, depending on the control panel selection. The second transponder is used as a backup.
- Configuration B shows the TCAS linked to a single transponder Mode S transponder system.
- Configuration C shows the TCAS linked to a single Mode S transponder (active) and an ATRBS transponder (backup). The TCAS only operates when the Mode S transponder is selected.



# SYSTEM DESCRIPTION AND INSTALLATION MANUAL

## TCAS 3000 Traffic Alert and Collision Avoidance System

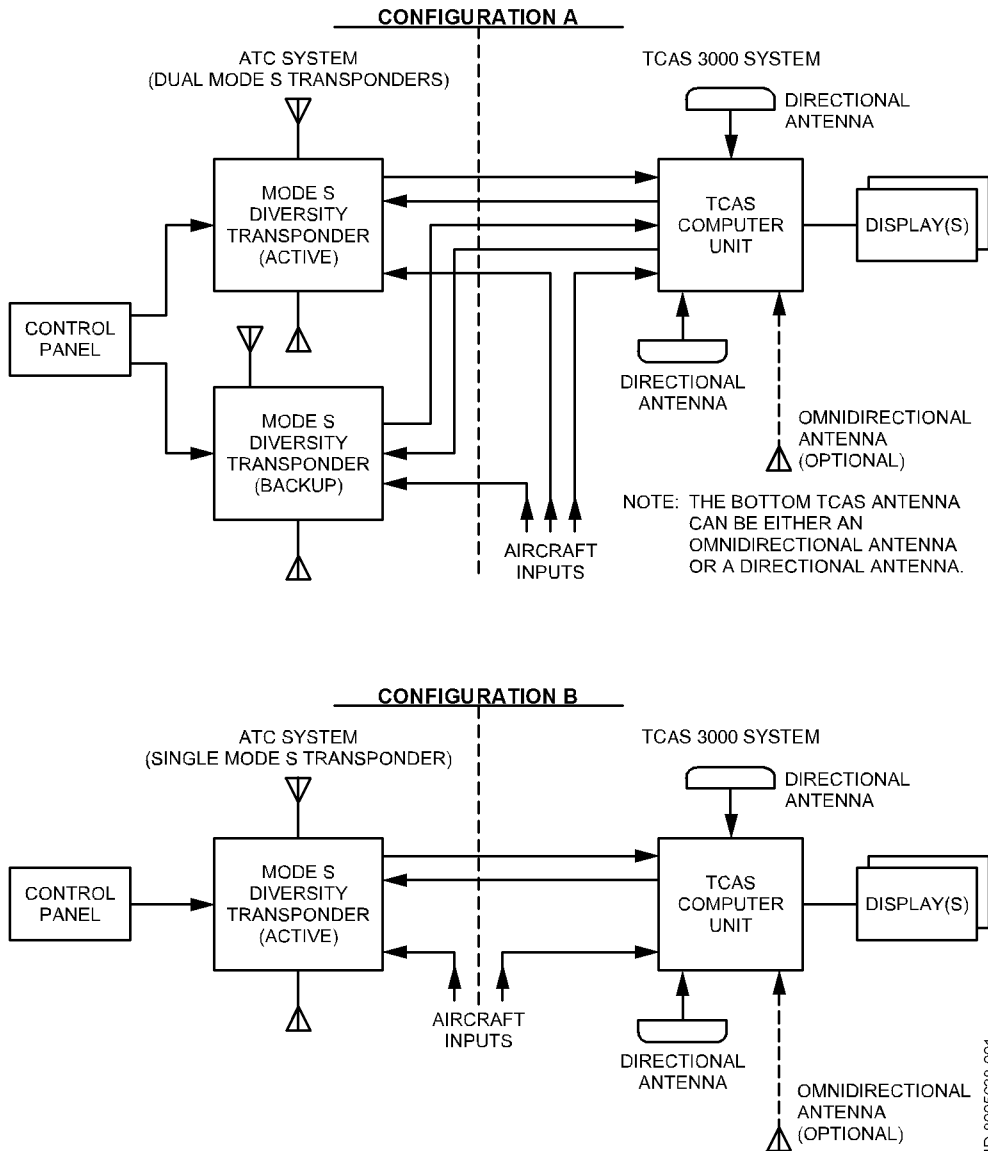

Figure 1-5 (Sheet 1). Typical System Configurations





**SYSTEM DESCRIPTION AND INSTALLATION MANUAL**  
TCAS 3000 Traffic Alert and Collision Avoidance System

**Configuration C**

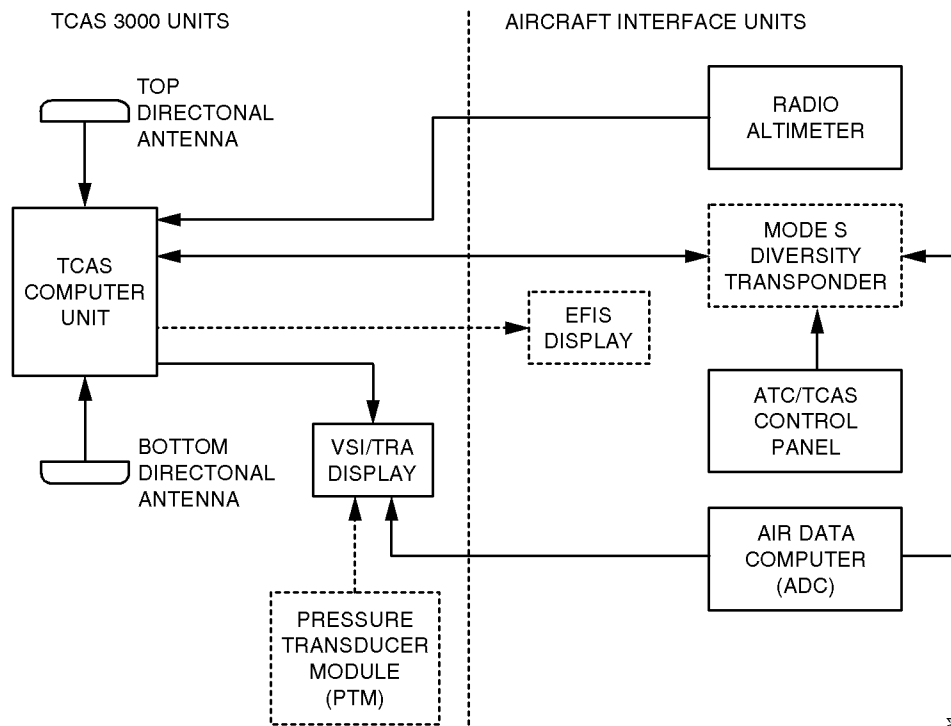

NOTE: DASHED BOXES / LINES DENOTE OPTIONAL ALTERNATE COMPONENTS. THE PTM IS AN ALTERNATE FOR THE ADC AND THE EFIS IS AN ALTERNATE FOR THE VSI/TRA.

ID-8005637-001

**Figure 1-5 (Sheet 2). Typical System Configurations**



**SYSTEM DESCRIPTION AND INSTALLATION MANUAL**  
TCAS 3000 Traffic Alert and Collision Avoidance System

Blank Page



**SYSTEM DESCRIPTION AND INSTALLATION MANUAL**  
 TCAS 3000 Traffic Alert and Collision Avoidance System

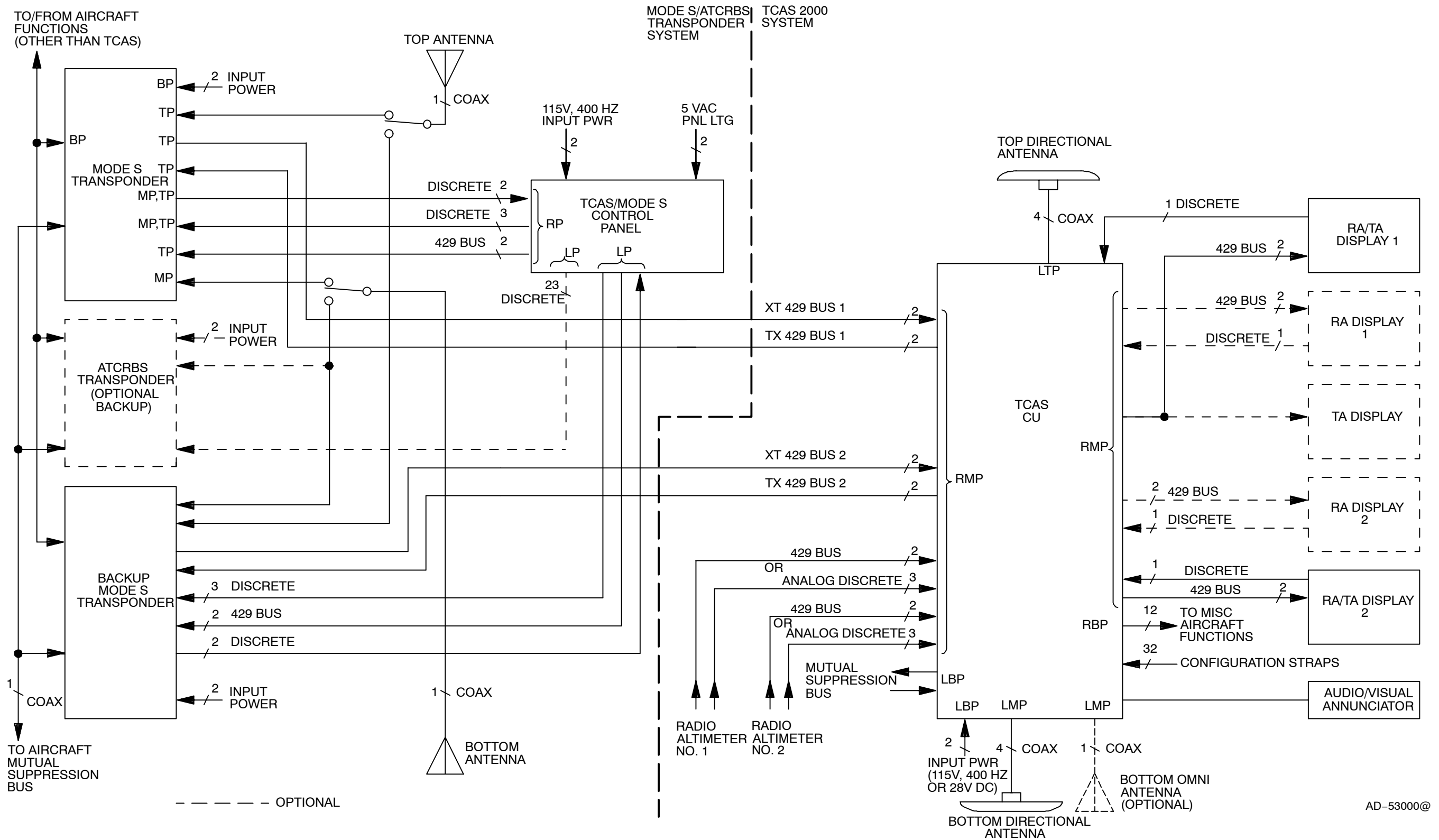

AD-53000@

Figure 1-6. TCAS 3000 System Block Diagram



**SYSTEM DESCRIPTION AND INSTALLATION MANUAL**  
TCAS 3000 Traffic Alert and Collision Avoidance System

#### 4. Component Descriptions

##### A. TCAS 3000 Computer Unit

The TCAS Computer Unit (CU) is the heart of the TCAS 3000 system. It contains the RF transmitter and the receivers necessary to interrogate and receive replies from other transponder equipped aircraft. Dual microprocessors are utilized to implement the surveillance and collision avoidance algorithms. The algorithms determine whether an intruder aircraft should be considered a threat and then determine the appropriate vertical response to avoid a midair or near midair collision. In addition, output data is provided to drive displays that inform the flight crew what action to take or avoid.

An interface is provided with an onboard Mode S transponder in order to communicate with other TCAS II equipped aircraft. The ACSS TCAS Computer Unit also provides past and present LRU and system status through the front panel mounted TEST switch and PASS/FAIL annunciators. Software updates can be incorporated into the computer by an ARINC 615 data loader port through either the connector mounted on the front panel of the computer or the port provided on the LRU rear connector or with a compact flash card inserted into the slot on the front of the LRU.

Figure 1-7 shows a graphical view of the 6MCU TCAS Computer Unit and Figure 1-8 shows a graphical view of the 4MCU TCAS Computer Unit. Table 1-6 provides items and specifications that are particular to the computer.

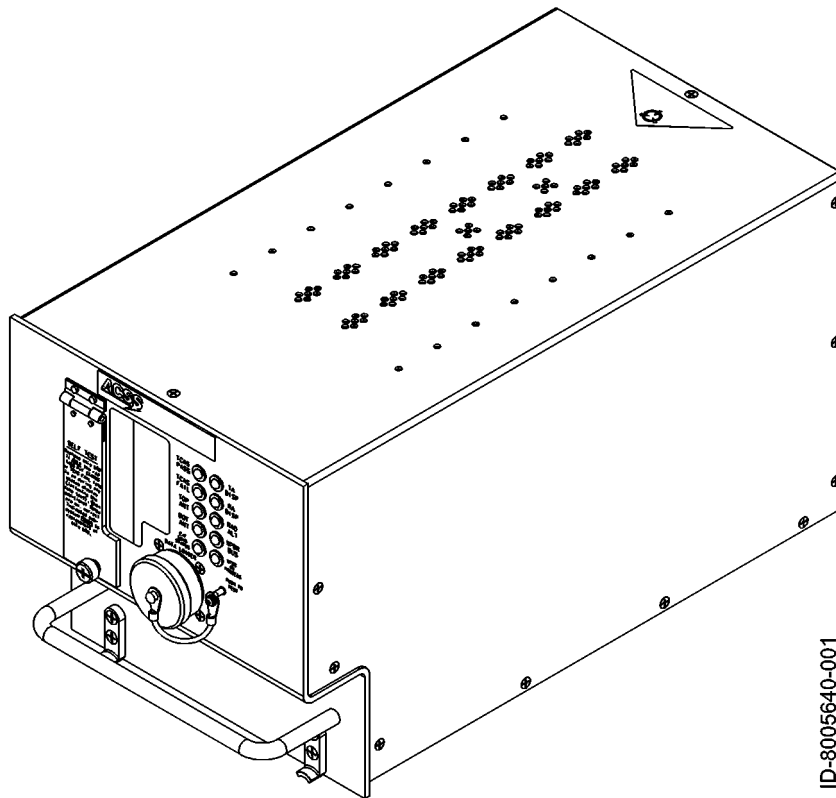

**Figure 1-7. 6MCU TCAS Computer Unit**



**SYSTEM DESCRIPTION AND INSTALLATION MANUAL**  
TCAS 3000 Traffic Alert and Collision Avoidance System

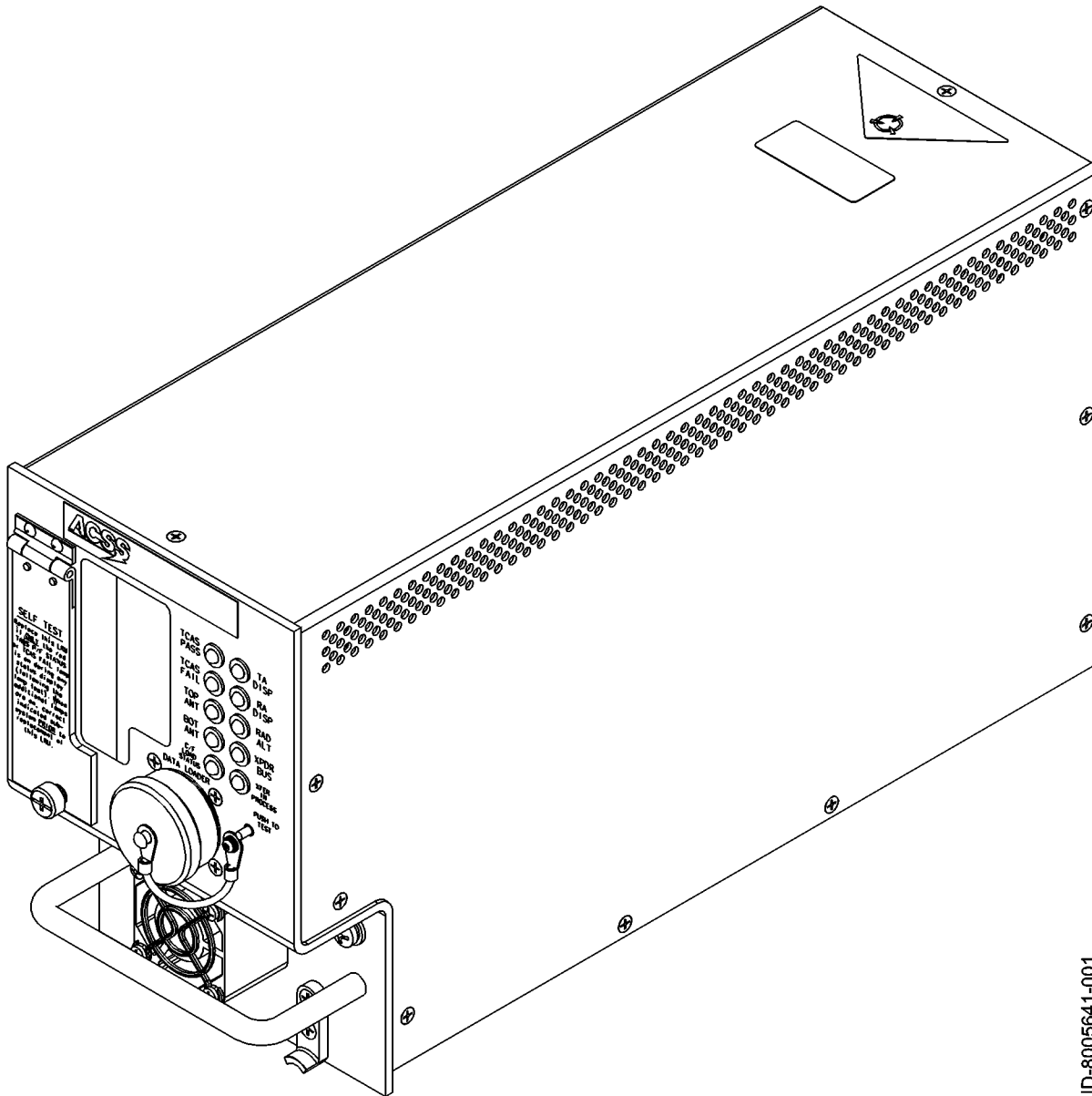

ID-8005641-001

**Figure 1-8. 4MCU TCAS Computer Unit**



**SYSTEM DESCRIPTION AND INSTALLATION MANUAL**  
TCAS 3000 Traffic Alert and Collision Avoidance System

**Table 1-6. TCAS 3000 Computer Unit Leading Particulars**

Item	Specification
Dimensions (maximum):	
• Height .....	7.64 in. (194.1 mm)
• Width (4MCU) .....	4.90 in. (124.5 mm)
• Width (6MCU) .....	7.52 in. (191.0 mm)
• Length (4MCU) .....	15.26 in. (387.6 mm)
• Length (6MCU) .....	15.76 in. (400.3 mm)
Weight (maximum):	
• 4MCU DC only version .....	14.0 lb (6.37 kg)
• 4MCU DC/AC version .....	14.7 lb (6.66 kg)
• 6MCU .....	17.6 lb (8.00 kg)
Operating Voltage:	
• dc Voltage .....	+20.5 V dc minimum, +27.5 V dc nominal, +32.2 V dc maximum
• ac Voltage .....	97 V rms minimum, 115 V rms nominal, 134 V rms maximum at 400 ± 80 Hz
Power Consumption .....	70 Watts standby, 100 Watts maximum
Circuit Breaker Ratings:	
• 115 V ac Circuit Breaker .....	5 Amp Typical
• 28 V dc Circuit Breaker .....	10 Amp Typical
Mating Connector:	
• P1 (Rear Connector) .....	Radial Part No. 620-800-066
• J1 (Front Connector) .....	ACSS Part No. 4004295-160, ITT Part No. KJ6F18A53P
Mounting:	
• 6MCU .....	ARINC 600 6-MCU Tray Assembly
• 4MCU .....	ARINC 600 4-MCU Tray Assembly
TSO:	
• All units .....	C119b
ETSO .....	C119b
Software Development Specification .....	DO-178B, Level B
Environmental Specifications .....	DO-160D Environmental Category [A2F2]YBB [CLMY][E1]XXXXXZ [EBZ]A[EZ]ZRZA3EXX



**SYSTEM DESCRIPTION AND INSTALLATION MANUAL**  
TCAS 3000 Traffic Alert and Collision Avoidance System

**Table 1-6. TCAS 3000 Computer Unit Leading Particulars (cont)**

Item	Specification
• Temperature / Altitude [A2F2]:	
- Operating Temperature .....	-55 to +70 degrees C
- Ground Survival Temperature .....	-55 to +85 degrees C
- Altitude .....	Sea Level to 55,000 feet
- Loss of Cooling .....	+40 degrees C for 300 minutes minimum
RF Transmitter Characteristics:	
• Transmitter Frequency .....	1030 ± 0.01 MHz
• RF Peak Output Power:	
- Minimum .....	53.3 dBm (210 Watts)
- Nominal .....	55.3 dBm (335 Watts)
- Maximum .....	57.3 dBm (540 Watts)
• Unwanted Output Power in an Inactive State .....	-72 dBm
• Pulse Timing Characteristics:	
- Pulse Rise Time .....	0.05 to 0.10 microseconds
- Pulse Fall Time .....	0.05 to 0.20 microseconds
- ATCRBS S1, P1, P3, P4 Duration .....	0.08 ± 0.05 microseconds
- Mode S P1, P2 Duration .....	0.08 ± 0.05 microseconds
- Mode S P6 Duration .....	16.25 ± 0.125 microseconds (short) 30.25 ± 0.125 microseconds (long)
• Whisper-Shout Characteristics:	
- Range .....	0 to 26 dB attenuation by 1 dB steps
- Absolute Tolerance .....	Relative to the 0 dB step, the attenuation of each step does not exceed the nominal attenuation by more than ±2 dB
- Relative Tolerance .....	Step increments are ±0.5 dB and monotonic
RF Receiver Characteristics:	
• Receiver Frequency Range .....	1087 to 1093 MHz
• Receiver MTL Over Frequency (Normal Operation) .....	-77 ± 2 dBm (≥90% Mode S and ATCRBS replies decoded)
• Receiver Dynamic Range (Normal Operation) .....	-77 to -23 dBm (≥99% Mode S and ATCRBS replies for signal levels greater than MTL +3 dB)



**SYSTEM DESCRIPTION AND INSTALLATION MANUAL**  
TCAS 3000 Traffic Alert and Collision Avoidance System

**Table 1–6. TCAS 3000 Computer Unit Leading Particulars (cont)**

Item	Specification
• Extended Range Reception Capability . . . . . (Optional Mode)	–82 ± 2 dBm (≥90% Mode S squitter replies decoded)
• Low Level Receiver Signal Rejection . . . . . (Normal Operation)	–81 dBm (≤10% Mode S and ATCRBS replies decoded)
• Receiver Signal Processing . . . . .	Amplitude Mono–pulse
• System Bearing Accuracy . . . . .	Error less than 9 degrees RMS, 27 degrees peak from –10 to +10 degrees elevation

(1) System Interfaces

The TCAS 3000 Computer Unit supports the external system interfaces that follow. Unless otherwise specified, the specifications apply to both the 6–MCU and 4–MCU computers. All interfaces are per ARINC 735A.

(a) Radio Altimeter Interface

The TCAS 3000 Computer Unit accepts either analog or digital radio altimeter inputs. For each type of input, dual input ports are provided.

Each of the military radio altimeter types provide two outputs that are connected to the TCAS CU input pins. The two altimeter outputs are the Analog Data Output and Analog Data Reliability signal. The TCAS CU uses the Data Reliability signal in conjunction with the Analog Data Output to determine radio altimeter failures.

A condition exists for several military radio altimeters known as Out of Track. This condition occurs when the radio altimeter has not failed and the altimeter is not reading a valid altitude. Altitude data for an Out of Track condition should be considered invalid and not used.

The digital radio altimeter interface accepts inputs from an ARINC 707 radio altimeter on ARINC 429 low speed input busses.

(b) Mode S Transponder Interface

The TCAS 3000 computer contains two sets of ARINC 429 high speed busses for communication with two Mode S transponders. It uses ARINC 718–A/735 communication protocol (2 inputs, 2 outputs).

(c) Onboard Maintenance System Interface

The TCAS 3000 computer contains a set of ARINC 429 low speed busses for communication with an onboard maintenance system (1 input, 1 output). The unit interfaces with all major airframe manufacturers maintenance computer systems. Since the maintenance computer protocol for each airframe manufacturer is different, the TCAS 3000 automatically detects the type of airframe from the data received from the maintenance computer and sets its protocol accordingly.





## SYSTEM DESCRIPTION AND INSTALLATION MANUAL

TCAS 3000 Traffic Alert and Collision Avoidance System

### (d) Data Loader Interface

The TCAS 3000 computer contains a set of ARINC 429 busses and discrete inputs that interface to either an airborne data loader (ADL) through pins on the rear connector, or a portable data loader (PDL) through the 53-pin circular connector on the front panel of the unit. The computer works with ARINC 615 data loader protocol (high speed bus). The unit software part number can be output on the data loader port by grounding a discrete input.

### (e) RS-232 / Compact Flash Card Data Recorder Interface

The Data Recorder Interface can be utilized for either internal or external data recording.

The TAWS/RWS event log contains event information due to TAWS or windshear cautions or warnings (internal data recording). The log can hold approximately three events that last up to 45 seconds each (assuming GCAM Event, GCAM parameter data, and GFM parameter data selected for recording). The event log data may be downloaded to a Laptop PC over the RS-232 port, or downloaded to a Compact Flash card using the slot on the front of the unit.

The external data recording provides the capability to perform real-time recording of various T<sup>2</sup>CAS input, output, and internal data. This data may be recorded using the Compact Flash card or RS-232 interface.

In addition, the RS-232 interface allows for LRU maintenance and troubleshooting. The maintenance log and RA event log can also be downloaded to a PC using this port. The RS-232 interface is connected to the 53-pin PDL connector on the front of the unit.

### (f) TCAS Display Bus interface

The TCAS 3000 computer has four sets of ARINC output busses for display of traffic and resolution advisories.

The TA/RA Display No. 1 and No. 2 busses are high speed ARINC 429 busses that contain both traffic information and resolution advisory information. The busses function according to either the ARINC 735 characteristics, or can optionally be set for the Honeywell EFIS characteristics through a program input pin (RMP-12C). For each bus, a valid discrete input is provided that indicates whether the display is functional.

The RA Display No. 1 and No. 2 busses are low speed ARINC 429 busses that contain only resolution advisory information. The busses function according to the ARINC 735 characteristics. For each bus, a valid discrete is provided that indicates whether the display is functional.

The RA Display No. 1 and No. 2 busses can be configured for a 429 Data Recorder function by grounding programming pin (RMP-11D). In this mode, the busses are configured for high speed operation.



## SYSTEM DESCRIPTION AND INSTALLATION MANUAL

TCAS 3000 Traffic Alert and Collision Avoidance System

(g) Performance Management Bus Interface

The TCAS 3000 computer contains a low speed ARINC 429 bus input (RMP-6A,6B) that is reserved for connection to a performance management system. The input is provisioned to obtain maximum rate of climb information from a FMS or Performance Management System (PMS.) The input is provided for future system enhancements and is currently not used.

(h) Magnetic Heading/Attitude Bus Interface

The TCAS 3000 computer contains a high speed ARINC 429 bus input (RMP-7A, 7B) that is reserved for connection to an Inertial Reference System (IRS). The input lets aircraft heading and attitude data be input for the purpose of providing for future horizontal maneuvers. This function has not been implemented on TCAS II installations, so these pins are reserved for future use.

(i) Compact Flash Flight Data Recorder Interface

The TCAS 3000 computer contains a Compact Flash card interface that provides flight data recording capability.

(j) ARINC 573 Flight Data Recorder Interface

The TCAS 3000 computer contains 12 discrete outputs that can be connected to an ARINC 573 flight data recorder. The outputs are used to record information during a resolution advisory event.

(k) ARINC 429 Flight Data Recorder Interface

The TCAS 3000 computer contains an interface for an ARINC 429 flight data recorder. The flight data recorder function is activated by grounding a discrete input pin (RMP-11D) on the rear connector. With the discrete input grounded, flight data is output as high speed ARINC 429 data on the RA Display No. 1 and No. 2 busses. With the discrete grounded, the normal RA Display bus operation is not available.

(l) Voice Audio Outputs

The TCAS 3000 computer contains two analog audio outputs that provide TCAS aural traffic advisories and resolution advisories. The 8-Ohm output has the capability to supply up to 4 Watts RMS into a speaker. The 600-Ohm output has the capability to supply up to 80 milliwatts RMS into an audio distribution system.

(m) RS-232 Interface

The TCAS 3000 computer has an RS-232 input/output for connection to a personal computer. The interface allows for LRU maintenance and troubleshooting. The maintenance log and RA event log can also be downloaded to a PC using this port. The RS-232 interface is connected to the 53-pin PDL connector on the front of the unit.



## SYSTEM DESCRIPTION AND INSTALLATION MANUAL

### TCAS 3000 Traffic Alert and Collision Avoidance System

#### (n) Altitude Alerter Interface

The TCAS 3000 computer contains an ARINC 429 low speed input bus that is reserved for receiving selected altitude information from an altitude control source or flight control computer. The TCAS computer uses the selected altitude information to inhibit the weakening of a resolution advisory by determining the selected altitude limits for the aircraft.

#### (o) Reserved ARINC 429 Bus Interface

The TCAS 3000 computer has four sets of reserved ARINC 429 input busses that can be configured as either high speed or low speed. These busses allow for future upgrades to the TCAS 3000 system without hardware modification.

#### (2) Discrete Inputs

The TCAS 3000 has various discrete inputs available for implementing various TCAS functions. The input logic status is defined according to ARINC 735 definition.

#### (3) Program Inputs

The TCAS 3000 has various program inputs available for unit configuration and installation programming. Input logic status is defined according to ARINC 735 definition.

#### (4) Discrete Outputs

The TCAS 3000 has a number of discrete outputs that are used for unit status annunciation and data output functions. The output logic status is defined according to ARINC 735 definition.

#### (5) Self-Test Function

By momentarily pushing the TEST switch on the front panel of the TCAS Computer Unit, maintenance personnel can display fault data for the current and preceding flight legs. When TEST is initially activated, all annunciators (pass/fail lamps on front of unit) are ON for a 3-second lamp test, then current fault data is displayed for 10 seconds. If no further activations of the TEST switch are made, the LRU display cycle is terminated at the end of the 10-second fault display period, and all annunciators are extinguished.

If during the 10-second fault display period, the TEST button is activated again, the fault display period is aborted, a 2-second lamp test cycle is done, and the fault data recorded for the preceding flight leg is displayed for 10 seconds. This procedure can be repeated up to 10 times to obtain recorded data from the previous 10 flight legs. If the TEST button is not activated again during the fault display period, the fault display cycle is terminated at the end of the 10-second fault display period and all annunciators are extinguished. If an attempt is made to display fault data for the preceding flight leg when the tenth preceding flight leg fault data is displayed, all annunciators flash for a 3-second period at a 2.5-Hz rate, after which all annunciators are extinguished.



## SYSTEM DESCRIPTION AND INSTALLATION MANUAL

### TCAS 3000 Traffic Alert and Collision Avoidance System

When less than 10 flight legs have been flown since the TCAS Computer Unit was shop tested and recertified, less than 10 previous flight legs of recorded fault data may be available for display. In this case, if an attempt is made to display fault data for the preceding flight leg when the earliest flight leg is displayed, all annunciators flash for 3 seconds at a 2.5-Hz rate and then all annunciators are extinguished.

The TCAS PASS and TCAS FAIL annunciators indicate the status of the TCAS Computer Unit only. All other annunciators reflect the condition of the respective sub-system. During troubleshooting, the TCAS Computer should not be removed if the TCAS PASS lamp is on.

#### B. Directional Antenna

The TCAS directional antenna, Figure 1-9, is a four-element, vertically polarized, monopole array capable of transmitting in four selectable directions at 1030 MHz. The antenna is capable of receiving replies from all directions simultaneously with bearing information at 1090 MHz, using amplitude-ratio monopulse techniques.

The antenna consists of a molded radome with radiating/receiving elements and is completely filled with a rigid foam. The antenna assembly uses five or nine screws to attach the radome and either four or eight screws to attach the antenna to the aircraft fuselage.

The ACSS directional antenna has a small frontal area. The circular radome has a 3:1 elliptical leading edge and an extremely low profile height of only 0.806 inch. This yields excellent aerodynamic performance with a minimum possibility of icing, which could be a hazard for rear mounted engines.

For TCAS 3000 system installations, the top antenna must be a directional antenna. The bottom antenna can be either a directional or omnidirectional antenna. The TCAS Computer Unit has the capability of automatically sensing which version is installed.

The directional antenna mounting screws (not included with the directional antenna) are standard #10-32 UNF-2A pan head, corrosion-resistant (stainless) steel screws in accordance with Military Specification MS51958. The appropriate length is determined by the installer allowing 0.5-inch for the thickness of the antenna and adapter plate. A washer must be installed under the head of each mounting screw. The washer must be made of passivated, corrosion-resistant steel in accordance with MIL-S-5059 or MIL-S-6721. The Air Force-Navy Aeronautical Standard part number is AN960C10L. The washer has an outer diameter of 0.438 inch, an inner diameter of 0.203 inch, and a thickness of 0.032 inch.



**SYSTEM DESCRIPTION AND INSTALLATION MANUAL**  
TCAS 3000 Traffic Alert and Collision Avoidance System

An O-ring (included with the directional antenna) is required to be installed between the directional antenna and the aircraft fuselage. The Navy Aeronautical Standard part number for the O-ring is NAS 1611-240. The ACSS part number for the O-ring is 4000171-240.

**NOTE:** For directional antennas, ACSS Part No. 7514060-90X, the customer must provide an adapter plate for mounting to the aircraft. For details of the antenna base plate, to which the adapter must mate, refer to Section 2. Directional antennas, ACSS Part No. 7514081-9XX, come with a preinstalled adapter plate.

The average unit weight of an antenna with adapter plate is approximately 3.0 pounds.



**SYSTEM DESCRIPTION AND INSTALLATION MANUAL**  
TCAS 3000 Traffic Alert and Collision Avoidance System

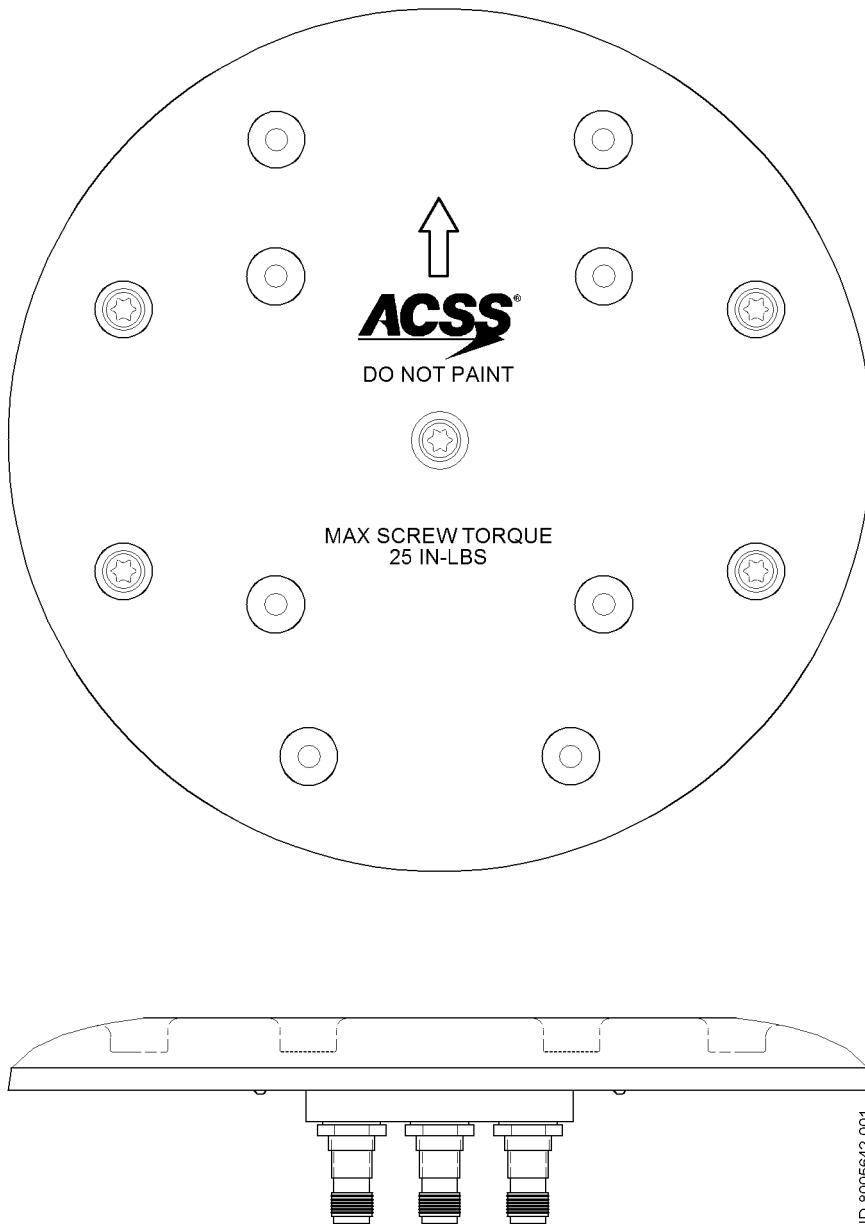

**Figure 1-9. Directional Antenna**



**SYSTEM DESCRIPTION AND INSTALLATION MANUAL**  
TCAS 3000 Traffic Alert and Collision Avoidance System

**C. ACSS Mode S/TCAS Control Panels**

The ACSS control panels for the transponder and TCAS systems provide mode control for dual or single ATC Mode S Transponders and TCAS II systems. Figure 1-10 shows a typical front panel layout of the two configurations. It is usually mounted in the aircraft instrument panel or the pedestal. Table 1-7 gives items and specifications particular to the unit.

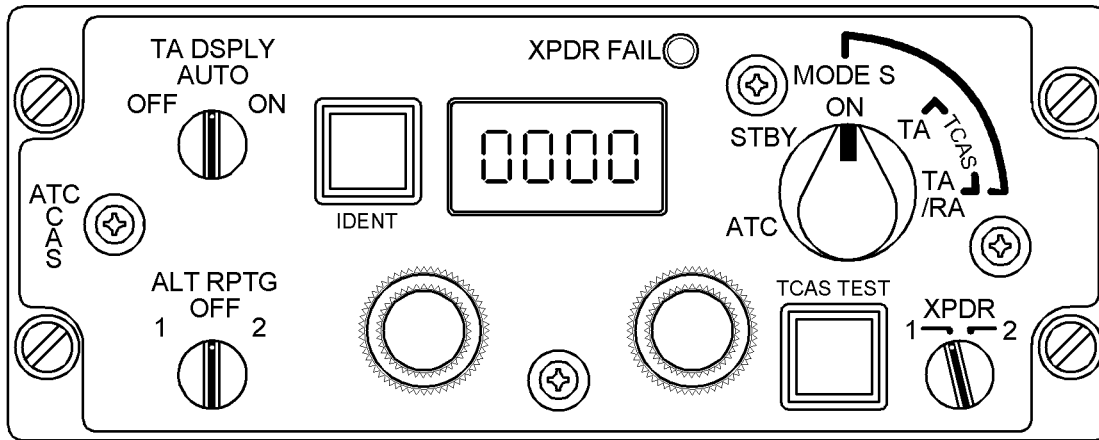

**DUAL MODE S/TCAS CONTROL PANEL**  
PART NO. 4052190-902, -904, -906, -908

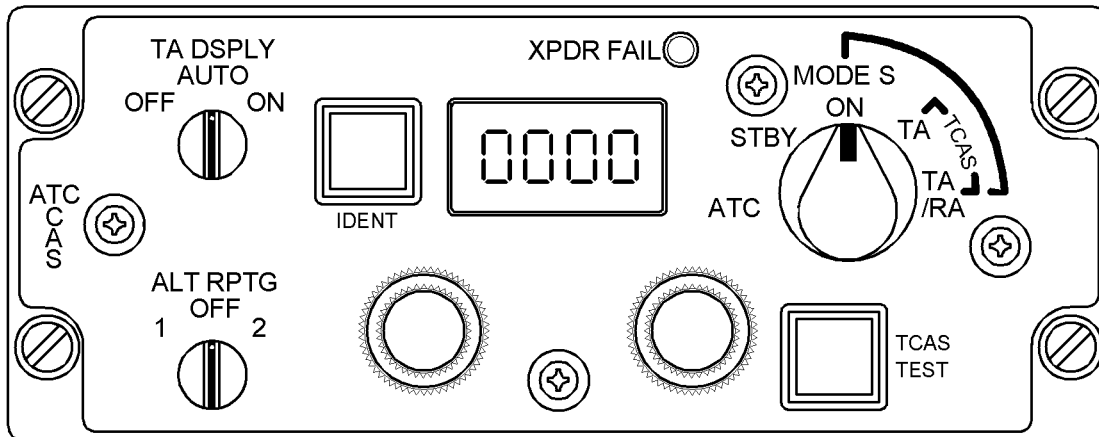

**ATCRBS AND MODE S/TCAS CONTROL PANEL**  
PART NO. 4052190-903, -905, -907, -909

AD-26785@

**Figure 1-10. ACSS Control Panels**



**SYSTEM DESCRIPTION AND INSTALLATION MANUAL**  
TCAS 3000 Traffic Alert and Collision Avoidance System

**Table 1–7. ACSS Control Panel Leading Particulars**

Item	Specification
Dimensions (maximum):	
• Height .....	2.25 in. (57.2 mm)
• Width .....	5.75 in. (146.1 mm)
• Length .....	5.00 in. (127.0 mm)
Weight (maximum) .....	2.1 lb (0.953 kg)
Power Requirements:	
• Primary .....	115 V, 400 Hz (2.0 Watts maximum)
• Lighting .....	5 V, 400 Hz (3.0 Watts maximum)
Mating Connectors:	
• J1 .....	M83723/75R1624S7
• J2 (Dual Mode S Version) .....	M83723/75R1624S8
• J2 (ATCRBS/Mode S Version) .....	MS3476L2041S
Mounting .....	Unit Dzus Fasteners

(1) Functional Description and Operation

Communication with Mode S transponders is accomplished through an ARINC 429 bus as defined in ARINC Characteristic 718–A. Control panel functions include 4096 ident code selection and display, altitude source and reporting inhibit selection, selection between two onboard transponders, TCAS TA or TA/RA advisory selection, and selection of TCAS test. A listing of the control panel switch functions is as follows:

(a) ALT RPGT Switch – 1, OFF, 2

Used to select between altitude sources 1 and 2, or to disable altitude reporting in transponder replies.

(b) XPDR FAIL – Annunciator

The illumination of the annunciator is an indication of a performance monitor failure detection.

(c) Mode Control – Rotary Switch

Disables reply capability in STANDBY mode. Enables MODE S transponder in ON mode. Enables ATCRBS transponder in ATC mode. The TA mode enables the TCAS computer, in conjunction with the Mode S transponder, to provide traffic advisories. The TA/RA mode enables the TCAS computer, in conjunction with the Mode S transponder, to provide traffic and resolution advisories. The TA and TA/RA modes are electrically tied to the ON mode and enable the Mode S transponder when selected.





## SYSTEM DESCRIPTION AND INSTALLATION MANUAL

TCAS 3000 Traffic Alert and Collision Avoidance System

(d) XPDR – Selector Switch (Dual Mode S Versions Only)

Selects the transponder, 1 or 2, that is used for reporting replies.

(e) TA DSPLY – OFF, AUTO, ON

Controls the operation of the navigation or traffic advisory display for a TCAS system.

(f) TCAS TEST – Button

Used to select the TCAS system self-test function.

(g) IDENT – Button

When pushed, this button causes an ATCRBS reply, or Mode S UF-4 and UF-5 replies, to contain a special identifier pulse (SPI) as an identifier to the ground according to ARINC 718-A Draft 5 of Supplement 4.

(h) 4096 Ident Code – Dual Concentric Rotary Knobs

Each rotary switch is used to set each individual digit of the four-digit ident code. The left inner knob selects the thousands digit, left outer knob selects the hundreds digit, right inner knob selects the tens digit, and the right outer knob selects the ones digit.

### D. Gables ATC/TCAS Dual Mode S Transponder Control Panel

The Gables ATC/TCAS Mode S control panel is used to independently control two Mode S transponders, and to interface with a Mode S installation with TCAS capabilities.

The control panel contains two isolated electronic modules each dedicated to a given transponder. Each module derives its input ATC code data from two dual concentric knobs. The selected code is then displayed on a four digit Liquid Crystal Display (LCD), and subsequently transmitted to each transponder.

Figure 1-11 shows a typical front panel layout of a Gables G7130 series control panel. Table 1-8 gives items and specifications that are particular to these units.

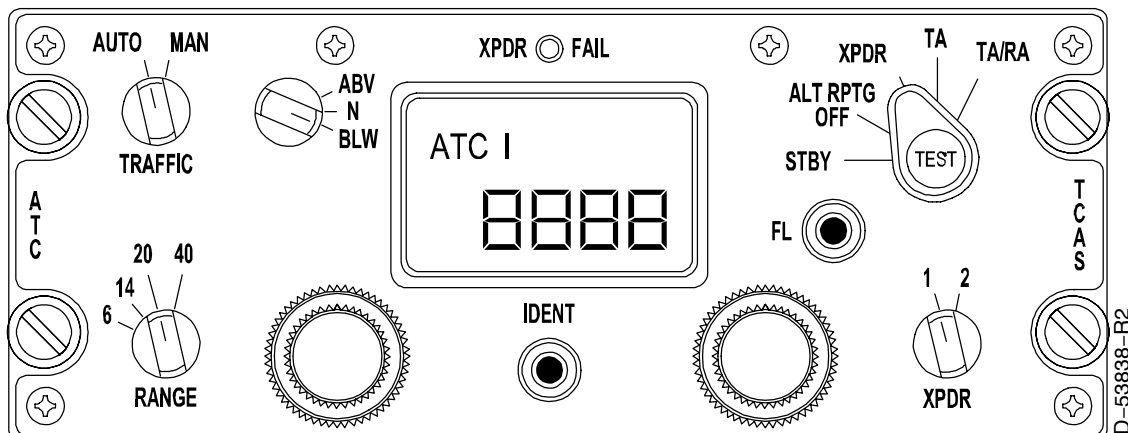



**SYSTEM DESCRIPTION AND INSTALLATION MANUAL**  
TCAS 3000 Traffic Alert and Collision Avoidance System

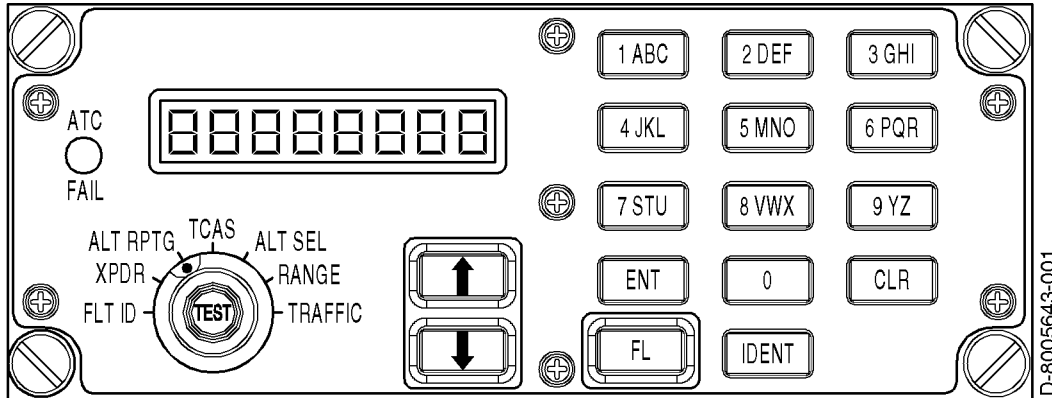

**Figure 1-11. Typical Gables ATC/TCAS Control Panel**

**Table 1-8. Gables G7130/G7490 Series Control Panel Leading Particulars**

Item	Specification
Dimensions (maximum):	
• Height .....	2.25 in. (57.2 mm)
• Width .....	5.75 in. (146.1 mm)
• Length .....	5.80 in. (147.3 mm)
Weight (maximum) .....	2.0 lb (0.907 kg)
Power Requirements:	
• Primary .....	+28 V dc, 0.25 Amps maximum current
• Display and Overlay Lighting .....	5 V, 400 Hz, 2.3 Amps maximum
Display Type .....	Four Digit, Dichroic LCD
Code Select Range .....	0000 to 7777 (octal)
Transmitted ARINC 429 Labels .....	013, 015, 016, 031 (octal)
TSO .....	C112/C119
Environmental Specifications .....	/A2D1/BB/MB·/XXXXXXZZAZZRZ/xxZZ
Mating Connectors:	
• J1 .....	M83723/75R16247 or MS24266R16B24S7
• J2 .....	M83723/75R16248 or MS24266R16B24S8
Mounting .....	Four Unit Dzus Fasteners



## SYSTEM DESCRIPTION AND INSTALLATION MANUAL

### TCAS 3000 Traffic Alert and Collision Avoidance System

#### (1) Functional Description and Operation

Communication with Mode S transponders is accomplished through an ARINC 429 bus as defined in ARINC Characteristic 718–A. Control panel functions include 4096 ident code selection and display, altitude source and reporting inhibit selection, selection between two onboard transponders, TCAS TA or TA/RA advisory selection, range selection (in nautical miles) and a system functional test selection. A description of the front panel annunciator and switch functions follows:

##### (a) Transponder Code Display

The control panel has a single LCD display that is common to both modules within the unit. The display shows the ATC code selected by the user and consequently transmitted to the transponders. Input to the display is controlled by the system select switch (XPNDR 1–2).

In addition, certain fault indications are also indicated on the display. After a functional test has been initiated, PASS shows on the display after a successful test, or it shows FAIL if a high level failure is detected under normal operating conditions. It also shows which transponder is active by displaying ATC 1 or 2.

##### (b) ATC Code Selection

The ATC four digit code is selected with two dual concentric sets of knobs. Each knob is dedicated to a single liquid crystal display (LCD) digit on the LCD code display. The two smaller knobs control the inner digits of the LCD (tens and hundreds) while the two larger knobs control the outer most digits (units and thousands).

##### (c) XPNDR 1–2 Switch

The XPNDR switch is a two position switch that allows the selection of one Mode–S module in the control panel, and the activation of its associated transponder (System 1 or System 2).

##### (d) Mode Control Selector Switch

The rotary switch labeled STBY–ALT RPTG OFF–XPNDR–TA ONLY–TA/RA allows the operator to activate the TCAS system by selecting TA, or traffic and resolution advisory (TA/RA). When STBY is selected, both transponders are selected inactive or in standby mode. Altitude reporting off (ALT RPTG OFF) selection disables the altitude data sources interrupting transmission of aircraft altitude and location information to ground controllers.

##### (e) ABV/N/BLW Switch

The ABV/N/BLW switch selects an altitude range (from aircraft) for traffic display on the TCAS displays. Range limits are 9900 feet above and 2700 feet below the aircraft when in ABV mode and 2700 feet above and 9900 below the aircraft when in BLW mode. When the normal (N) position is selected, the display range is 2700 feet above and below the aircraft.



## SYSTEM DESCRIPTION AND INSTALLATION MANUAL

TCAS 3000 Traffic Alert and Collision Avoidance System

(f) Traffic Display Switch

The TRAFFIC AUTO–MAN switch is a two position rotary switch that controls the TCAS traffic display mode of operation. When the AUTO mode is selected, the TCAS computer sets the TCAS displays to pop–up mode under a traffic/resolution advisory condition. If the MAN mode is selected, then the TCAS displays will be constantly activated advising of any near by traffic detected within the horizontal and vertical range limits.

(g) Range Switch

The RANGE switch is a four or six position rotary switch used to select among different nautical mile (NM) traffic advisory horizontal range displays.

(h) IDENT Key

The IDENT key is a momentary button. When pushed, the IDENT key causes an ATCRBS reply or Mode S UF–4 and UF–5 replies to contain a special pulse identifier pulse (SPI) as an identifier to be transmitted to ground controllers in accordance with ARINC 718–A Draft 5 of Supplement 4.

(i) Flight Level Button

The FL button is a momentary button used to select between relative and absolute altitude information. When absolute is selected, this mode is enabled for approximately 20 seconds and then reverts back to relative.

(j) Test Button

The TEST button enables the user to initiate a system functional test. When the TEST button is pushed, the control panel initiates an internal test while a functional test output is also transmitted through ARINC 429 labels.

When installed with a TCAS system, an extended test can be initiated by continuously pushing the TEST button for at least eight seconds.

(k) XPNDR FAIL Annunciator

The XPNDR FAIL annunciator displays the functional status of the active transponder. The fail annunciator lights only when a failed transponder is selected on the XPNDR 1–2 switch.

(l) FID Switch

The Keypad is used to create or enter the Flight ID for output by the transponder. The display will show the Flight ID code that has been entered by the crew. The FID light will illuminate when in this mode.

When FID mode is selected, all keys are active. The active keys are used to create the Aircraft Flight ID code for transmission to ATC.



## SYSTEM DESCRIPTION AND INSTALLATION MANUAL

### TCAS 3000 Traffic Alert and Collision Avoidance System

For 0 thru 9, press the appropriate digit to enter a new code. When the first digit of a new code is pressed, the digit display field is cleared, the display shows that digit in the left-most digit field with the other digits blanked and the FID indicator will flash. CLR can be pressed while in the process of entering digits to clear the digit field and allow entry of a new code. Pressing CLR again will result in the display of the previously active code. Upon completing entry of the FID code, pressing ENT results in transmission of the new FID in about five (5) seconds. If the ATC mode is selected before pressing ENT, the partial entry is retained in memory and the FID indicator continues to flash. Upon returning to the FID mode, the new FID code entry process can be completed. The FID indicator will stop flashing when ENT is pressed.

For letters A–Z, repeatedly press the appropriate key until the desired letter appears in the display. The first press of any key will cause the digit to appear in the display. The second press of the same key within 2 seconds will cause the digit to change to the first letter on that key. The third press of the same key within 2 seconds will cause the letter to change to the second letter on that key. The next press within 2 seconds will cause the letter to change to the third letter on the key pad (if applicable). The next press within 2 seconds will cause the letter to change back to the digit on the key. Waiting 2 seconds between key presses, or pressing another key at any time, will advance the cursor to the next character space or will cause the digit of the key pressed to appear in the next location on the display. Flight ID can be between 1 and 8 characters in length.

#### E. VSI/TRA Display

The VSI/TRA display, Figure 1–12, is used to display current vertical speed and TCAS traffic/warning information. The display consists of a full color, active matrix, liquid crystal display panel. The display quality compares favorably to CRT displays but requires less power, weight, and volume than a CRT with a similar display area. Table 1–9 gives items and specifications particular to the unit. Figure 1–13 contains an interface block diagram of the 41-pin version VSI/TRA and Figure 1–14 contains an interface block diagram of the 55-pin (bootstrap) version of the VSI/TRA.



**SYSTEM DESCRIPTION AND INSTALLATION MANUAL**  
TCAS 3000 Traffic Alert and Collision Avoidance System

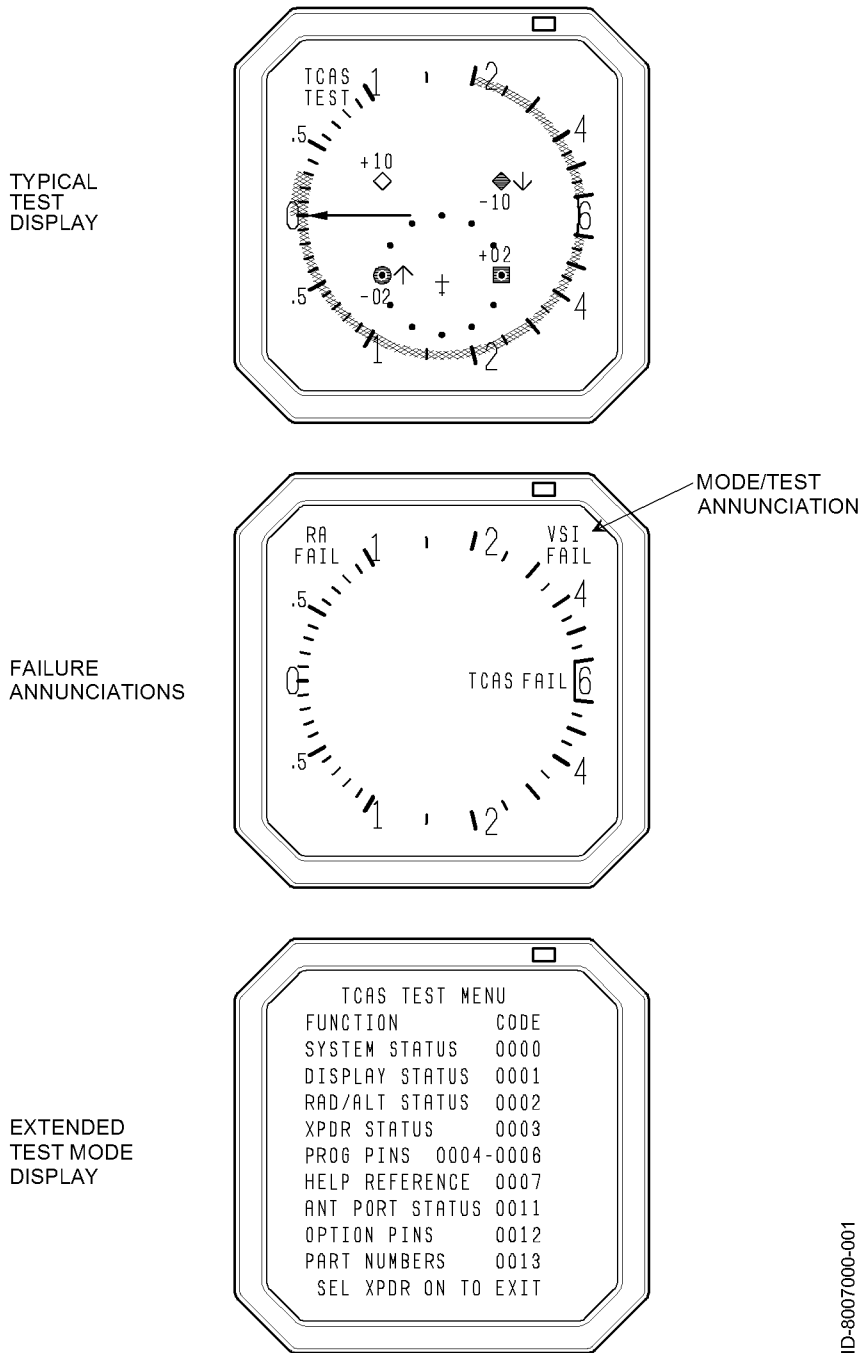

**Figure 1-12. Typical VSI/TRA Display Formats**



**SYSTEM DESCRIPTION AND INSTALLATION MANUAL**  
TCAS 3000 Traffic Alert and Collision Avoidance System

**Table 1–9. VSI/TRA Leading Particulars**

Item	Specification
Dimensions (maximum):	
• Height .....	3.26 in. (82.8 mm)
• Width .....	3.26 in. (82.8 mm)
• Length .....	9.42 in. (239.3 mm)
Weight (maximum) .....	4.0 lb (1.81 kg)
Power Requirements:	
• Primary .....	115 V, 400 Hz; 18 Watts nominal, 31 Watts maximum
• External Circuit Breaker Rating .....	1 Amp at 115 V ac
Display Type .....	Liquid Crystal
Mating Connectors:	
• J1 (41 Pin Version) .....	M83723/75R–20–41N
• J1 (55 Pin Version) .....	M83723/75R–22–55N
Mounting .....	3–ATI Clamp, Marmon NH1004994–30 or MSP 64311B
Environmental Specifications (DO–160B) .....	(A2F1)AKXXXXXXAEAEZZK

(1) Functional Description and Operation

The VSI/TRA has three functions. It continuously displays rate of climb or rate of descent. Traffic information is displayed and resolution advisory information is displayed against vertical speed to allow the flight crew to avoid threats.

The vertical speed display is generated from signals applied directly to the indicator. The VSI/TRA is designed to be used in place of a conventional vertical speed indicator. Four possible sources exist for vertical speed data including ARINC 429 data, DC analog signals in accordance with ARINC 575 (approximately 500 mV per 1000 ft/min), ac analog signals in accordance with ARINC 565 (approximately 250 mV per 1000 ft/min), and ARINC 429 signals from the ACSS Pressure Transducer Module. The VSI/TRA computes vertical rate from electrical static pressure when a remote static sensor is used. These four program pin selectable configurations provide compatibility with most aircraft.

Bootstrapping of vertical speed inputs as currently implemented on L–1011, A300, A310 and A300–600 aircraft, is provided with a larger 55–pin unit connector. These units have a unique dash number assigned to them.

Various dash number VSI/TRA Displays are available that provide unique design characteristics, which include VSI rate filter programming and selection of an English or metric rate scale. Table 1–5 contain a listing of all the VSI/TRA configurations.



## SYSTEM DESCRIPTION AND INSTALLATION MANUAL

### TCAS 3000 Traffic Alert and Collision Avoidance System

The VSI/TRA also displays symbology corresponding to traffic in the vicinity of the aircraft. Threat information is received from the TCAS Computer Unit on a dedicated high-speed ARINC 429 bus. The display uses the bearing, altitude, and range data for each threat to provide an indication of the proximity of the threat. Allowable (nonilluminated or green illuminated bands) and prohibited (red illuminated bands) vertical rates are displayed based on information received from the TCAS computer unit. The VSI/TRA can be pin programmed to provide vertical speed data only, vertical speed and resolution advisory data, or vertical speed, resolution advisory and traffic advisory data. Display of the TCAS system fault status is provided on the VSI/TRA in response to extended TCAS control panel TEST activation.

Display dimming is controlled from several inputs consisting of an internal light sensor mounted on the bezel of the LRU, a remote light sensor, and the aircraft dimming bus. The display is dimmed by varying the brightness of the LCD panel backlighting.

#### (2) Software Considerations

VSI/TRA software is developed to a DO-178A category of Level II (essential). The software continually monitors and displays vertical speed and TCAS information. Output discretes supply user components with the status of the LRU. TCAS valid indicates that the LRU is displaying valid TCAS information. On the 55-pin version, VSI valid indicates that the LRU is displaying valid vertical speed information. This is needed to support the bootstrap feature, which is exclusive to the 55-pin version of the VSI/TRA display.

#### (3) Built-In Test Equipment (BITE) and Self-Test Capability

The LRU has input discretes that allow a calibration and test program to be run. This mode allows the display to be adjusted and various diagnostic tests to be performed. These tests and adjustments can only be done in a shop on a dedicated test fixture.

When the LRU application program is operating in the aircraft, the background loop continuously monitors the power supply status, the ROM integrity, and the analog range limits. A failure results in the setting of bad status output discretes. A cold start will continuously be attempted until the LRU passes the built-in test. There is a dedicated self-test input for both versions of the VSI/TRA Display. When this pin is activated, the unit will display symbology that aids in the detection of unit faults.





**SYSTEM DESCRIPTION AND INSTALLATION MANUAL**  
TCAS 3000 Traffic Alert and Collision Avoidance System

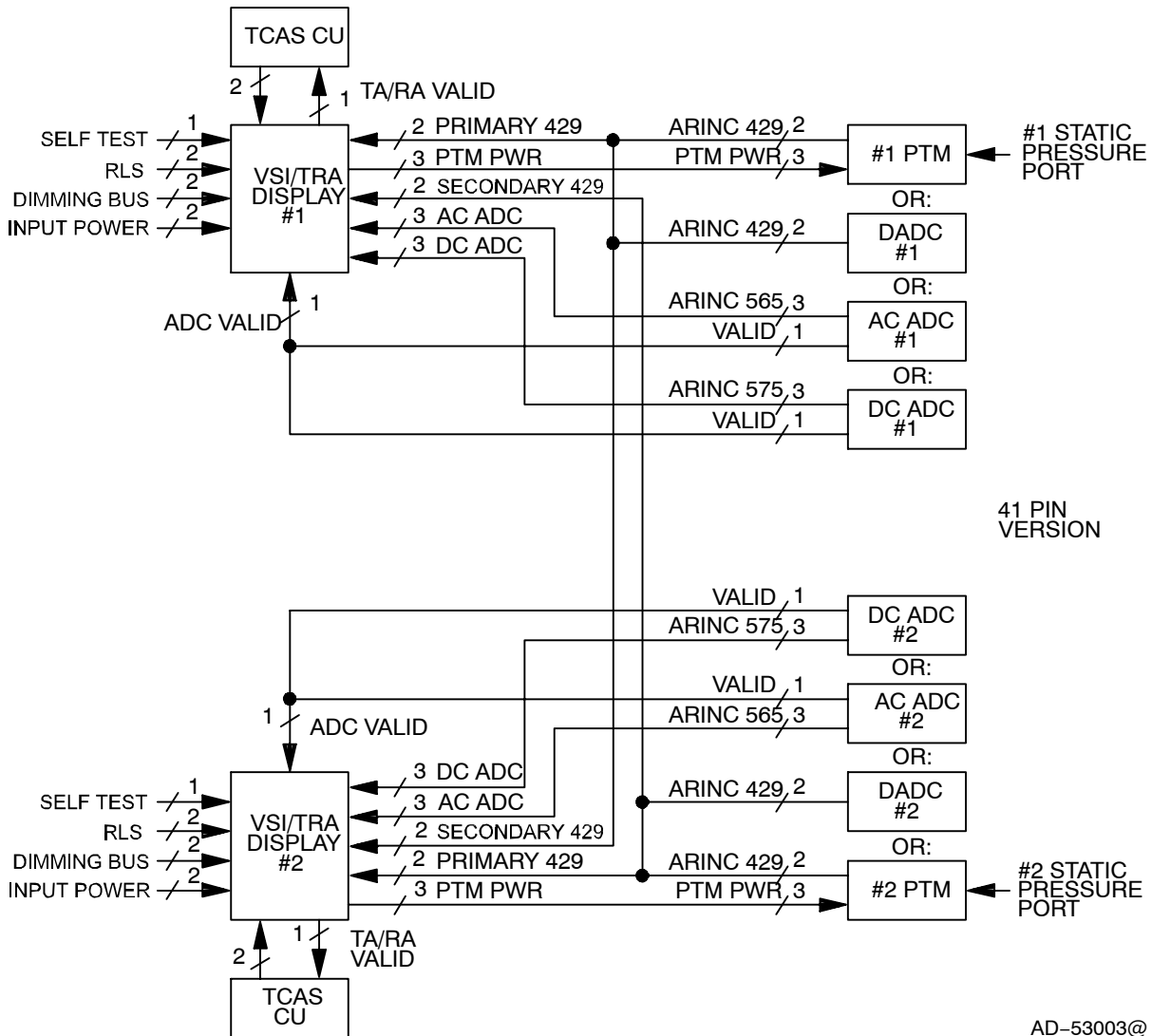

**Figure 1-13. VSI/TRA Interface Diagram (41-Pin Version)**



**SYSTEM DESCRIPTION AND INSTALLATION MANUAL**  
TCAS 3000 Traffic Alert and Collision Avoidance System

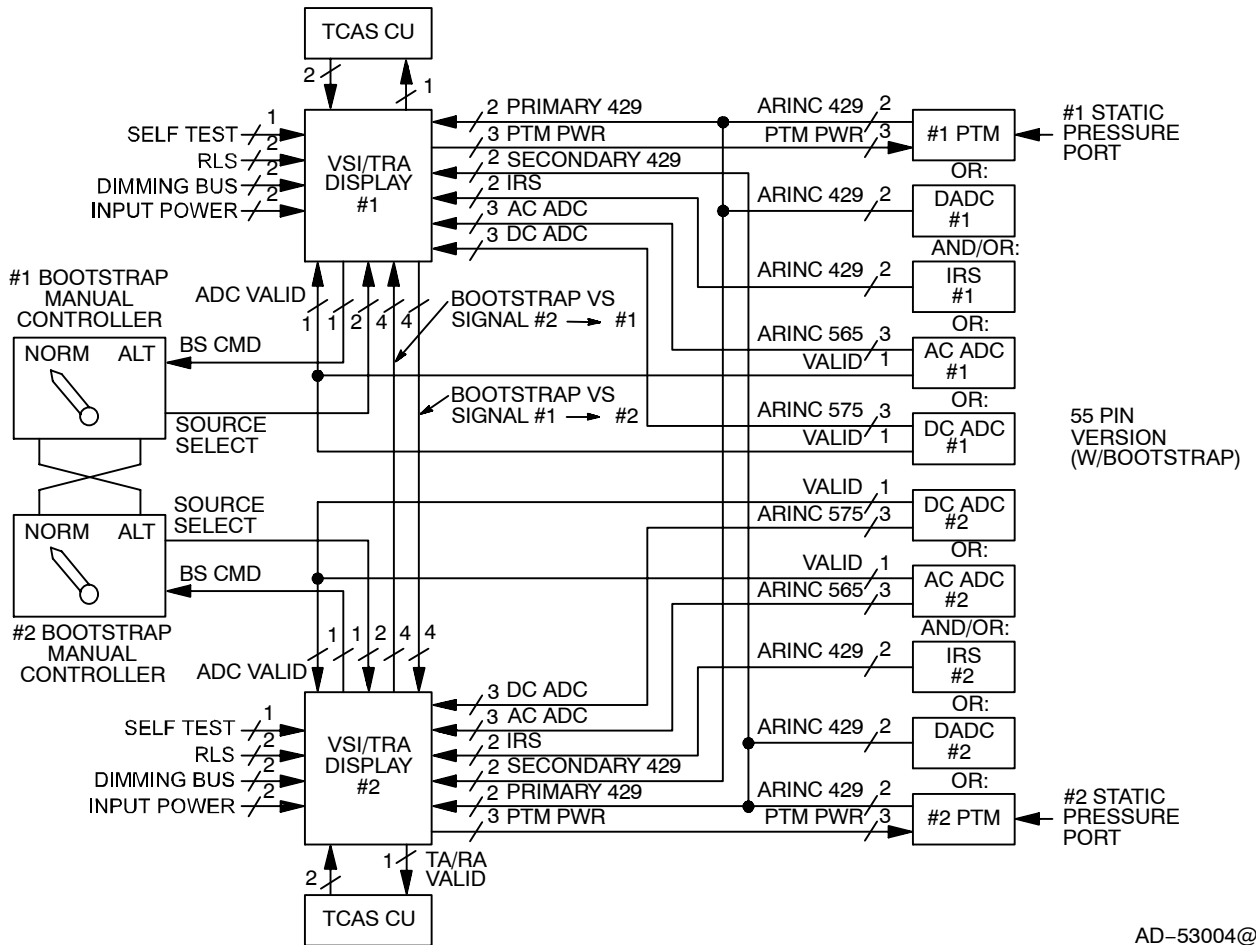

AD-53004@

**Figure 1-14. VSI/TRA Interface Diagram (55-Pin Version)**



**SYSTEM DESCRIPTION AND INSTALLATION MANUAL**  
TCAS 3000 Traffic Alert and Collision Avoidance System

**F. Pressure Transducer Module**

The Pressure Transducer Module (PTM) converts static pressure to a low speed ARINC 429 signal used by the VSI/TRA to calculate altitude rate. Figure 1-15 shows a graphical view of the PTM. The PTM can be mounted in any pressurized area of the aircraft. Table 1-10 gives items and specifications particular to the unit.

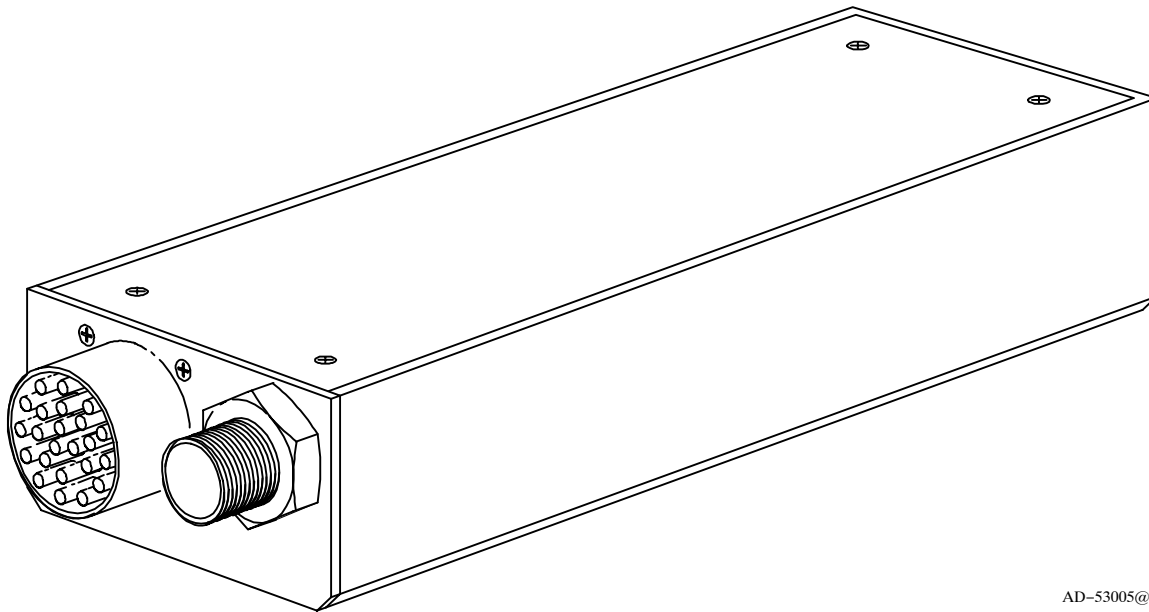

AD-53005@

**Figure 1-15. Pressure Transducer Module**



**SYSTEM DESCRIPTION AND INSTALLATION MANUAL**  
TCAS 3000 Traffic Alert and Collision Avoidance System

**Table 1-10. Pressure Transducer Module Leading Particulars**

Item	Specification
Dimensions (maximum):	
• Height .....	1.6 in. (40.6 mm)
• Width .....	2.8 in. (71.1 mm)
• Length .....	7.5 in. (190.5 mm)
Weight (maximum) .....	2.0 lb (0.091 kg)
Power Requirements .....	±12 V DC derived from VSI/TRA ±15 V power supply
Power Consumption .....	2.0 Watts nominal
Mating Connectors:	
• J1 (Electrical Connector) .....	15 Pin Round, M83723/75A1415N
• (Pneumatic Fitting) .....	Flareless nipple, NAS 1760-06
Mounting .....	A mounting bracket is available for use in a limited access area or an ARINC 408A 3-ATI round plate is available for mounting in the instrument panel

The PTM contains a pressure sensor packaged in a TO-8 header case and measures by a strain gage mechanism. The pressure sensor converts pressure that range from 3.0 to 33.0 inHg into a differential output voltage. Contained within the sensor are the strain sensing element, sensor heater, and temperature sensing diode.

The PTM meets the specifications that follow after the altitude rate has been calculated from the static pressure source:

- The input pressure range is from 3.0 to 33.0 inHg, which covers the altitude range of -2,000 to +50,000 feet
- The applied altitude rate ranges from 0 to ±6000 ft/min
- The PTM is capable of detecting and input pressure variation of 25 ft/min
- The PTM is capable of tracking input signals of 40 ft/sec without performance degradation.

The PTM is designed to send a power down message to the VSI/TRA. This is the only BITE capability of this unit.



## SYSTEM DESCRIPTION AND INSTALLATION MANUAL

TCAS 3000 Traffic Alert and Collision Avoidance System

### G. XS-950 Mode S Data Link Transponder

The XS-950 Data Link Transponder provides surveillance functions to ground based and airborne interrogators, and communication functions to various onboard systems. The transponder contains data link functions that allow it to function as part of the Aircraft Telecommunications Network (ATN). The data link functions allow communication with a Communication Management Unit (CMU) through a Mode S Airborne Data Link Processor (ADLP). The transponder also contains Mode S specific functions that are dedicated links to onboard systems. The XS-950 Transponder has the capability to be upgraded to provide an internal airborne data link processor (ADLP) function.

The XS-950 Transponder conforms to the ARINC 718-A Mode S Transponder Characteristic for form, fit and function, and is backward compatible with existing ARINC 718-A installations. It is certified to ICAO level IV data link capability and can be upgraded to level V data link capability.

The XS-950 Data Link Transponder is packaged in a 4-MCU (Modular Concept Unit) outline as defined in ARINC Characteristic 600-7. The unit is able to utilize ARINC 404 cooling air moving through the LRU in a downward direction as well as ARINC 600 cooling air moving through the LRU in an upward direction. The rear connector receptacle is an ARINC 600 size 2 shell assembly with inserts and contacts as defined in ARINC Characteristic 718-A. The unit also features a fixed carrying handle and self-test button with discrete LRU STATUS annunciators.

Figure 1-16 shows a graphical view of the XS-950 Data Link Transponder and Table 1-11 gives items and specifications that are particular to the transponder.

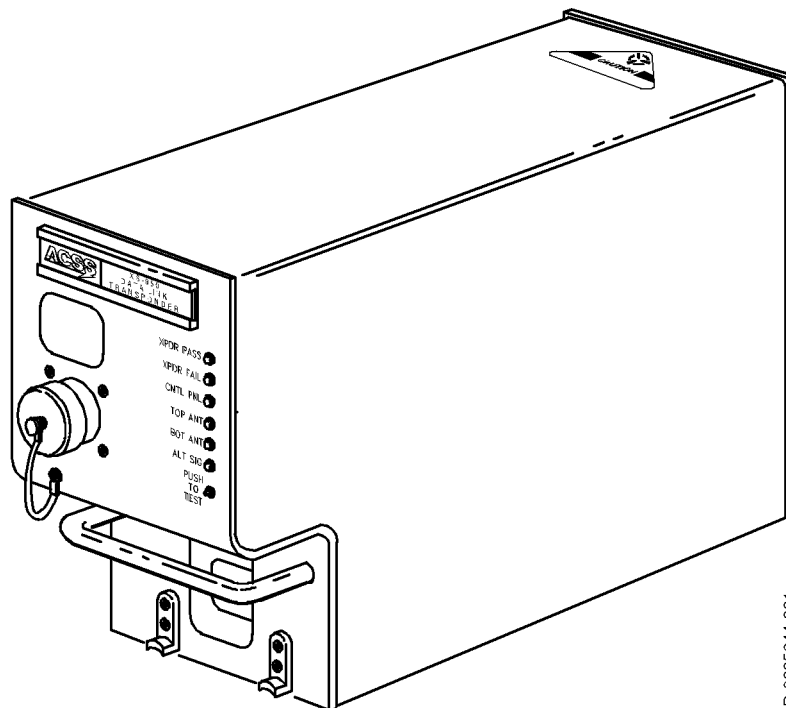

Figure 1-16. XS-950 Data Link Transponder



**SYSTEM DESCRIPTION AND INSTALLATION MANUAL**  
TCAS 3000 Traffic Alert and Collision Avoidance System

**Table 1–11. XS–950 Data Link Transponder Leading Particulars**

Item	Specification
Dimensions (maximum):	
• Height .....	7.6 in. (192 mm)
• Width .....	4.9 in. (124.5 mm)
• Length .....	15.2 in. (386 mm)
Weight .....	11.5 lb (5.2 kg)
Power Requirements (115 V ac version):	
• Operating Voltage .....	97 to 134 V rms, 115 V rms nominal
• Operating Frequency .....	320 to 480 Hz, 400 Hz nominal
• Power Consumption:	
– Standby Mode (No Replies) .....	40 Watts maximum
– Active mode (Maximum Load) .....	85 Watts maximum
• External Circuit Breaker Rating .....	5 A at 115 V ac, 400 Hz
Power Requirements (28 V dc version):	
• Operating Voltage .....	+18.0 to +32.2 V dc, +27.5 V dc nominal
• Power Consumption:	
– Standby Mode (No Replies) .....	40 Watts maximum
– Active mode (Maximum Load) .....	85 Watts maximum
• External Circuit Breaker Rating .....	7 A at 28 V dc
Mating Connector .....	Radial Part No. NSXN2P203X0005
Mounting .....	ARINC 600 4MCU Tray Assembly
TSO .....	C112, CL043, 121, F11
Environmental Specifications: .....	
– 115 V ac version .....	[A2E1]–BB[CLMY]XXXXXXZEAZRZA3E3XX
– 28 V dc version .....	[A2E1]–BB[CLMY]XXXXXXZ[BZ]AZZRZA3E3XX
• Temperature / Altitude [A2E1]:	
– Operating Temperature .....	–55 to +70 degrees C
– Ground Survival Temperature .....	–55 to +85 degrees C
– Altitude .....	Sea Level to 70,000 feet
– Loss of Cooling .....	+40 degrees C for 30 minutes minimum



**SYSTEM DESCRIPTION AND INSTALLATION MANUAL**  
TCAS 3000 Traffic Alert and Collision Avoidance System

**Table 1-11. XS-950 Data Link Transponder Leading Particulars(cont)**

Item	Specification
• Vibration [CLMY]:	
– Category C .....	Fixed wing turbojet engine, fuselage mounting
– Category L .....	Fixed wing reciprocating and turboprop multi and single engine over 12,500 pounds, fuselage mounting
– Category M .....	Fixed wing reciprocating and turboprop multi and single engine less than 12,500 pounds, instrument panel/console and equipment rack mounting
– Category Y .....	Helicopter, reciprocating and turbojet, fuselage mounting
Operating Modes:	
• STANDBY .....	Ready but not replying
• ATC ON .....	Transponder Modes A and S, no altitude reporting
• ATC ALT .....	Transponder Modes A, C, and S. Altitude reporting is enabled
Transmitter Frequency .....	1090 ±1.0 MHz
Transmitter Power .....	640 Watts maximum peak pulse, 250 Watts minimum
Receiver Frequency .....	1030 MHz
Minimum Trigger Level (MTL) .....	-76 ± 3 dBm
Mutual Suppression .....	Bidirectional, accepts +18 to +70 volt pulse input; provides +28 volt nominal output
Controller Interface:	
• Circuit Configuration .....	Two ARINC 429 control data input ports. 12.5 K bits/s (low-speed ARINC)
• Bus Protocol .....	Bus protocol meets requirements defined in ARINC 718-A for receiving transponder and TCAS control information.
TCAS II Interface:	
• Circuit Configuration .....	ARINC 429 input and output bus. 100 K bits/s (high-speed ARINC)
• Bus Protocol .....	Bus protocol meets requirements defined in ARINC 718-A and ARINC 735A-1 for standard transponder to TCAS interface



**SYSTEM DESCRIPTION AND INSTALLATION MANUAL**  
TCAS 3000 Traffic Alert and Collision Avoidance System

**Table 1-11. XS-950 Data Link Transponder Leading Particulars(cont)**

Item	Specification
Airborne Data Link Processor (ADLP) Interface:	
<ul style="list-style-type: none"> <li>• Circuit Configuration .....</li> </ul>	COMM-A/B messages have an ARINC 429 input and output bus. COMM-C/D messages have an ARINC 429 input and output bus. Both sets of busses are 100 K bits/s (high-speed ARINC).
<ul style="list-style-type: none"> <li>• Bus Protocol .....</li> </ul>	Bus protocol meets requirements defined in ARINC 718-A for standard transponder to ADLP bus interface.
Altimeter Interface:	
<ul style="list-style-type: none"> <li>• Digital Air Data .....</li> </ul>	ARINC 429 or 575 data format. 12.5 K bits/s (low-speed ARINC). Two altimeter inputs (left and right altimeters).
<ul style="list-style-type: none"> <li>• Synchro Altitude .....</li> </ul>	ARINC 407 data format. Fine and course 3-wire synchro inputs and a synchro valid flag discrete input. Two sets of synchro altimeter inputs (left and right altimeters).
<ul style="list-style-type: none"> <li>• Analog Altitude (-20012, -65012 Only) .....</li> </ul>	Three wire proportional input with valid flag discrete input. Two altimeter inputs (left and right altimeters). Discrete input to enable altitude comparison.
<ul style="list-style-type: none"> <li>• Encoding Altimeter .....</li> </ul>	Gillham altitude data format. 11-wire discrete input. Two altimeter inputs (left and right altimeters).
<ul style="list-style-type: none"> <li>• Altitude Selection .....</li> </ul>	Altitude source (left and right) selected by discrete input.
Airframe Parameter Data Interface:	
<ul style="list-style-type: none"> <li>• Circuit Configuration .....</li> </ul>	ARINC 429 input busses. High (100K bits/s) or Low (12.5 K bits/s). Speed, auto-detected by transponder.
<ul style="list-style-type: none"> <li>• Bus Protocol .....</li> </ul>	Aircraft parameters required to support Elementary and Enhanced Surveillance (ELS/EHS) as well as Extended Squitter. Bus protocol and input ports as defined in ARINC 718-A, minimum subset..
Aircraft Air/Ground Status Interface .....	Two discrete inputs used to indicate the aircraft air/ground status.
Maintenance Computer Interface:	
<ul style="list-style-type: none"> <li>• Circuit Configuration .....</li> </ul>	ARINC 429 input and output bus. 12.5 K bits/s (low-speed ARINC).





**SYSTEM DESCRIPTION AND INSTALLATION MANUAL**  
 TCAS 3000 Traffic Alert and Collision Avoidance System

**Table 1-11. XS-950 Data Link Transponder Leading Particulars(cont)**

Item	Specification
<ul style="list-style-type: none"> <li>• Bus Protocol . . . . .</li> </ul>	The maintenance computer interface meets protocol requirements for all model Airbus, Boeing, and McDonnell Douglas maintenance computers.
Onboard Software Uploading / Maintenance Log Downloading:	
<ul style="list-style-type: none"> <li>• Circuit Configuration . . . . .</li> </ul>	<u>Portable Data Loader thru ARINC 615 Front Panel Connector</u> ARINC 429 input and output bus (100 K bits/s) PDL Link A discrete input RS-232 input/output bus (38.4 K bits/s) at 53-pin PDL connector <u>Airborne Data Loader thru Unit Rear Connector</u> ARINC 429 input and output bus (100 K bits/s) ADL Link A discrete input
<ul style="list-style-type: none"> <li>• Bus Protocol . . . . .</li> </ul>	Software uploads thru ARINC 429 PDL (front panel) port or ARINC 429 ADL (rear connector) port per the protocol in ARINC 615 high-speed data loader  Maintenance log downloads thru ARINC 429 PDL port or ARINC 429 ADL port per the protocol in ARINC 615 high-speed data loader  Software uploads and maintenance log downloads can be accomplished through the PDL front panel port with an RS-232 interface bus and a PC with terminal emulation software



## SYSTEM DESCRIPTION AND INSTALLATION MANUAL

TCAS 3000 Traffic Alert and Collision Avoidance System

### H. RCZ-852 Diversity Mode S Transponder

The RCZ-852 Diversity Mode S Transponder is an airborne transponder designed to perform both conventional and advanced air traffic control (ATC) functions. It receives coded radar signals from ATC ground stations and other aircraft and transmits coded replies. The replies contain information such as aircraft identity, altitude, and data communication messages.

The transponder works with the air traffic control radar beacon system (ATCRBS) and mode select (Mode S) system to provide enhanced surveillance and communications capability required for air traffic control system automation and onboard collision avoidance systems. It has antenna diversity and is defined as a Class 3A transponder with TCAS interface capability. The RCZ-852 Diversity Mode S Transponder has the capabilities that follow:

- Surveillance functions of both ATCRBS and Mode S ground sensors
- Surveillance functions of airborne interrogators
- Bi-directional air-to-air information exchanges, COMM-U/V
- Ground-to-Air data uplink, COMM-A
- Air-to-Ground data downlink, COMM-B
- Multisite message protocol
- Ground-to-Air extended length message (ELM), COMM-C.

The transponder does not support COMM-D extended length message (ELM) communication.

Figure 1-17 shows a graphical view of the RCZ-852 Diversity Mode S Transponder and Table 1-12 gives items and specifications that are particular to the transponder.

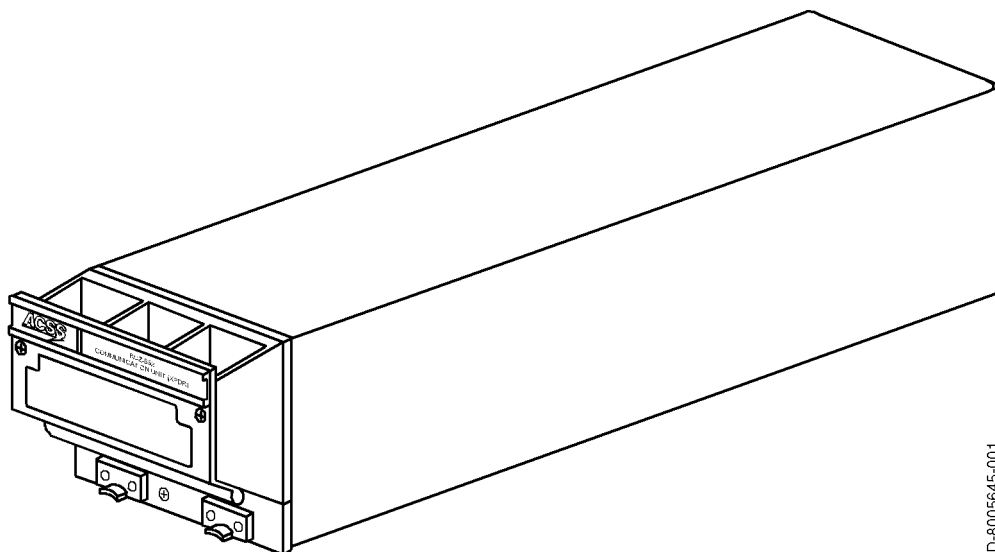

ID-8005645-001

Figure 1-17. RCZ-852 Diversity Mode S Transponder



**SYSTEM DESCRIPTION AND INSTALLATION MANUAL**  
TCAS 3000 Traffic Alert and Collision Avoidance System

**Table 1–12. RCZ–852 Diversity Mode S Transponder Leading Particulars**

Item	Specification
Dimensions (maximum):	
• Height .....	3.38 in. (86 mm)
• Width .....	4.10 in. (104 mm)
• Length .....	14.1 in. (358 mm)
Weight .....	5.0 lb (2.27 kg)
Power Requirements:	
• Operating Voltage .....	+18.0 to +30.3 V dc, +27.5 V dc nominal
• Power Consumption:	
– Standby Mode (No Replies) .....	28 Watts nominal
– Active Mode (Maximum Load) .....	55 Watts maximum
• External Circuit Breaker Rating .....	5 A at +27.5 V dc
Mating Connector .....	ACSS Part No. 7500294–106, Tri–Star Part No. TRAP–106P–26(200); Cannon Part No. DPXAMA–21000–2491 (Part of Installation Kit, ACSS Part No. 7510707–968)
Mounting .....	Mount Assembly, ACSS Part No. 7517455–902
TSO .....	C112
Environmental Specifications .....	DO–160B Environmental Category /A2E1/B/JLMY/E1XXXXXZ/BZ/AZZ
• Temperature / Altitude [A2E1]:	
– Operating Temperature .....	–55 to +70 degrees C
– Ground Survival Temperature .....	–55 to +85 degrees C
– Altitude .....	Sea Level to 70,000 feet
– Decompression .....	8,000 to 70,000 feet
– Overpressure .....	–15,000 feet
• Vibration [JLMY]:	
– Category J .....	Fixed wing turbojet, subsonic and supersonic, fuselage mounting
– Category L .....	Fixed wing reciprocating and turboprop multi and single engine over 12,500 pounds, fuselage mounting



**SYSTEM DESCRIPTION AND INSTALLATION MANUAL**  
TCAS 3000 Traffic Alert and Collision Avoidance System

**Table 1–12. RCZ–852 Diversity Mode S Transponder Leading Particulars (cont)**

Item	Specification
- Category M .....	Fixed wing reciprocating and turboprop multi and single engine less than 12,500 pounds, instrument panel/console and equipment rack mounting
- Category Y .....	Helicopter, reciprocating and turbojet, fuselage mounting
Operating Modes:	
• STANDBY .....	Ready but not replying.
• ATC ON .....	Transponder Modes A and S. No altitude reporting.
• ATC ALT .....	Transponder Modes A, C, and S. Altitude reporting is enabled.
Transmitter Frequency .....	1090 ± 0.5 MHz
Transmitter Power .....	500 Watts peak pulse, 250 Watts minimum
Receiver Frequency .....	1030 MHz
Minimum Trigger Level (MTL) .....	-77 ± 3 dBm
Mutual Suppression .....	Bidirectional, accepts +18 to +70 volt pulse input, provides +28 volt nominal output
Controller interface:	
• Circuit Configuration .....	Two ARINC 429 control data input ports. 12.5 K bits/s (low-speed ARINC)
• Bus Protocol .....	Bus protocol meets requirements defined in ARINC 718–A for receiving transponder and TCAS control information.
TCAS II Interface:	
• Circuit Configuration .....	ARINC 429 input and output bus. 100 K bits/s (high-speed ARINC).
• Bus Protocol .....	Bus protocol meets requirements defined in ARINC 718–A and ARINC 735 for standard transponder to TCAS interface.
Airborne Data Link Processor (ADLP) Interface:	
• Circuit Configuration .....	COMM–A/B messages have an ARINC 429 input and output bus. COMM–C/D messages have an ARINC 429 input and output bus. Both sets of busses are 100 K bits/s (high-speed ARINC).
• Bus Protocol .....	Bus protocol meets requirements defined in ARINC 718–A for standard transponder to ADLP bus interface.



**SYSTEM DESCRIPTION AND INSTALLATION MANUAL**  
 TCAS 3000 Traffic Alert and Collision Avoidance System

**Table 1–12. RCZ–852 Diversity Mode S Transponder Leading Particulars (cont)**

Item	Specification
• Exception .....	COMM–D messages are not processed by this transponder.
Altimeter Interface:	
• Digital Air Data .....	ARINC 429 or 575 data format. 12.5 K bits/s (low–speed ARINC). Two altimeter inputs (left and right altimeters).
• IAC Air Data .....	Radio System Bus (RSB) interface supplies the Honeywell Integrated Avionics Computer (IAC) digital air data information. Two altimeter inputs (left and right altimeters).
• Encoding Altimeter .....	Gillham altitude data format. 11–wire discrete input. Two altimeter inputs (left and right altimeters).
• Altitude Selection .....	Altitude source (left or right) selected by a discrete input.
Flight Identifier Interface:	
• From Radio Management (RMU) .....	Flight identifier input from the RMU in RSB data format.
• From Flight Management System (FMS) .....	Flight identifier input from the FMS in ARINC 429 data format. 12.5 K bits/s (low–speed ARINC).
Aircraft Air/Ground Status Interface .....	Two discrete inputs used to indicate the aircraft air/ground status.
Antenna Selection Interface .....	A discrete output supplies a GROUND when transponder is active.
RCB Interface:	
• Circuit Configuration .....	2–wire full duplex RS–232 serial link to/from internal radio communications bus (RCB).
• Transmission Rate .....	187.5 K baud
• Transmission Format .....	1 start bit, 8 data bits and 1 stop bit
Shop Flash Memory Programming Interface:	
• Circuit Configuration .....	2–wire full duplex RS–232 serial port
• Transmission Rate .....	19.2 K baud
• Transmission Format .....	1 start bit, 7 data bits, odd parity and 1 stop bit



**SYSTEM DESCRIPTION AND INSTALLATION MANUAL**  
TCAS 3000 Traffic Alert and Collision Avoidance System

## **5. System Operation**

The principal modes of operation and display features of the TCAS 3000 are discussed in the paragraphs that follow. In-flight procedures with display examples are contained in the TCAS Pilot's Manual, ACSS Publication No. C28-3841-005.

### **A. Operational Modes**

The TCAS 3000 can operate in several different modes, depending on control panel selection. Several control panels are available. Only the ACSS single Mode S control panel is discussed. Other control panels provide similar features.

Four switches directly affect the TCAS operational mode: TCAS/XPDR mode selector, TA DSPLY selector, ALT RPTG selector, and TCAS TEST switch. To distinguish the modes that provide TCAS advisories from those that do not, the operational modes are discussed under TCAS modes and non-TCAS modes. The non-TCAS modes are annunciated TCAS OFF at the center of the display.

The extended test mode is mentioned for reference. A detailed description of its use can be found in the FAULT ISOLATION section.

#### **(1) TCAS Modes**

The TA/RA and the TA-only modes are the two TCAS operational modes. The TA/RA mode gives traffic information and warnings of hazardous traffic conflicts, while the TA mode gives only traffic information. A third mode, the TEST mode, can be temporarily activated from any mode including standby (STBY). The TEST mode does not inhibit the generation of advisories. Functions available in the operational and test modes are as follows:

##### **(a) TA/RA Mode**

This mode is the normal operation mode providing full TCAS coverage. In this mode, TCAS tracks all aircraft in the surrounding airspace and generates traffic advisories or resolution advisories, as the situation requires. Figure 1-3 contrasts the airspace covered for each kind of advisory.

For normal TA/RA operation, the TA/DSPLY selector must be set to AUTO or ON and the ALT/RPTG selector must be set to 1 or 2.

##### **(b) TA Mode**

The TA mode provides only surveillance of the surrounding airspace. In this mode, TCAS tracks all proximate aircraft and generates traffic advisories; no resolution advisories are issued in this mode.

The flight crew uses the TA-only mode when resolution advisories would be a nuisance, or when flying over an area where only TCAS surveillance is allowed. Also, the system automatically selects this mode when the aircraft is flying under 1000 feet above ground level (AGL).

The TA mode is annunciated TA ONLY at the upper left corner of the display.



## SYSTEM DESCRIPTION AND INSTALLATION MANUAL

### TCAS 3000 Traffic Alert and Collision Avoidance System

#### (c) Test Mode

Pushing the TEST button on the control panel starts a self-test program which verifies proper operation of the TA and RA displays and of the aural advisories on the audio system.

The test mode does not affect normal TCAS operation, provided the selected transponder remains in normal operation during the test cycle. Should a TA or RA occur during the test sequence, the test aborts, and the advisory is announced and displayed.

The test mode just described excludes extended self-tests performed on the ground, where TCAS is inoperative.

#### (2) Non-TCAS Modes

The control panel selections that follow disable TCAS operation and all advisories:

- MODE S ON activates a Mode S transponder only
- STBY sets the selected transponder in standby mode
- ATC activates an ATCRBS transponder only
- ALT RPTG set to OFF inhibits altitude reporting.

When TCAS is inoperative as a result of control panel selection, TCAS OFF is annunciated on the display. When TCAS is inoperative due to a system failure, TA FAIL, RA FAIL, or TCAS FAIL is annunciated on the display. In addition, if the transponder or the altitude data source fails, the XPDR FAIL light on the control panel comes on.

#### (3) Extended Test Mode

The purpose of the extended test mode is to facilitate diagnosis in the event self-test has failed. Like self-test, this mode is enabled by pushing the TCAS TEST button, but only when TCAS is inoperative. The aircraft must be on the ground, and the transponder must be set to STBY. Holding TCAS TEST pushed for longer than eight seconds in this condition activates the extended tests. This feature is not available on all systems. Refer to the TESTING AND FAULT ISOLATION section for system requirements and test description.



## SYSTEM DESCRIPTION AND INSTALLATION MANUAL

TCAS 3000 Traffic Alert and Collision Avoidance System

### B. Display Symbolology

The TCAS modes use color-coded symbols and data tags to map air traffic and locate threat aircraft on the VSI/TRA display.

Four traffic symbols are used: solid circle, solid square, solid diamond, and hollow diamond. See Figure 1-18 for examples. A different color is assigned to each symbol type, as listed in Table 1-13.

**Table 1-13. TCAS Traffic Symbols**

Graphic Symbol	Color	Display Function
Solid Circle	Amber	Traffic Advisory (TA)
Solid Square	Red	Resolution Advisory (RA)
Solid Diamond	Blue	Proximate Traffic
Hollow Diamond	Blue	Other Traffic

**NOTE:** TCAS traffic information displayed on EFIS displays such as crew alerting system display, navigation display, electronic horizontal situation display or multifunction display, is similar to that on combined VSI/TRA indicators. Traffic symbology is identical to that displayed on the VSI/TRA.

#### (1) Colors

##### (a) Amber

Represents a moderate threat to a TCAS-equipped aircraft. A visual search is recommended to prepare for intruder avoidance. Amber is used only in conjunction with a traffic advisory.

##### (b) Red

Represents an immediate threat to a TCAS-equipped aircraft. Prompt action is required to avoid the intruder. This color is only used in conjunction with a resolution advisory.

##### (c) Blue

Represents proximate traffic and other traffic the TCAS surveillance logic has in its track file.

##### (d) White

Used only for mode annunciations and for reference graphics, including aircraft home position, range ring, and VSI scale.





**SYSTEM DESCRIPTION AND INSTALLATION MANUAL**  
TCAS 3000 Traffic Alert and Collision Avoidance System

(2) Traffic Identification

(a) Traffic Advisory

Intruder aircraft entering the caution area, 20 to 48 seconds from the TCAS 3000 collision area are represented as a solid amber circle. This type of traffic results in a traffic advisory.

(b) Resolution Advisory

Intruder aircraft entering the warning area, 15 to 35 seconds from the TCAS 3000 collision area are represented as a solid red square. This type of traffic results in a resolution advisory.

(c) Proximate Traffic

Aircraft within 6.0 nautical miles and  $\pm 1200$  feet vertically are represented as a solid cyan diamond. Proximate traffic is shown to improve situational awareness in the event of a potential conflict with higher priority RA or TA aircraft.

(d) Other Traffic

Any transponder replying to traffic not classified as an intruder or proximate traffic, and within  $\pm 2700$  feet vertically and the range of the display are represented as hollow cyan diamonds (only in view with the traffic switch ON and no TA or RA in process). The predicted flightpaths of proximate and other traffic do not penetrate the collision area of the TCAS aircraft.

(3) Data Tags

A data tag, made up of a two-digit number, a plus (+) or a minus (-) sign, and may also include an arrow, appears either above or below the intruder aircraft symbol. The data tag appears in the same color as the advisory.

(a) Two-digit Number (Relative Altitude)

Represents the relative altitude difference, in hundreds of feet, either above or below the TCAS aircraft of an intruder aircraft. For an intruder above the TCAS aircraft, the data tag is placed above the traffic symbol and preceded by a plus (+) sign; for one below, the tag is placed below the traffic symbol and be preceded by a minus (-) sign.

(b) Plus (+) or Minus (-) Sign

Appears adjacent to the relative altitude number and indicates whether the displayed aircraft is above (plus) or below (minus) the TCAS aircraft.

(c) Arrow

A vertical arrow is placed to the immediate right of the traffic symbol if the intruder is either climbing (up arrow) or descending (down arrow) in excess of 500 feet per minute.



## SYSTEM DESCRIPTION AND INSTALLATION MANUAL

TCAS 3000 Traffic Alert and Collision Avoidance System

### (4) VSI Scale Overlays

During a resolution advisory, red and green bands overlay the VSI scale. The red band indicates what vertical speed range is to be avoided by the pilot (prohibited vertical speed). The green band indicates the vertical speed the pilot is to attain to achieve safe separation from a threat aircraft (recommended vertical speed). The red/green band reflects the RA in progress and acts as a vertical speed advisory for the pilot.

### (5) Reference Graphics and Annunciations

A white airplane symbol is displayed in the lower center of the VSI representing the aircraft own position. A white range ring made up of 12 dots, each corresponding to a normal clock position, is included. The range ring surrounds the airplane with a radius of 2 nautical miles and is intended to assist in interpreting TCAS traffic information.

The scale of the VSI display is 6.0 nautical miles to the top display edge of the VSI (ahead of the aircraft), 4 miles to the left and right edges, and 2.5 nautical miles to the bottom (behind the aircraft).

Annunciations in white letters serve as a reminder of the current operation mode. They include TCAS OFF, TA only and RA only. Fault annunciations in amber letters replace the mode annunciations in case of system failure. They include TCAS FAIL, RA FAIL, VSI FAIL, and TA FAIL (traffic display failure). Figure 1–12 shows a typical failure display.

## C. Aural Messages

The TCAS generates aural alerts or messages announced over the aircraft audio system. These messages accompany the visual TA or RA display and are softened or strengthened, depending on the urgency of the situation. The TCAS audio level is preset and is not adjustable by the aircrew.

If a logic change occurs before a message is completed and a new message is initiated, the original alert is terminated and the new alert announced immediately.

### (1) Requirements and Limitations

The following is a list of the requirements and limitations for issuing an aural advisory by the TCAS Computer Unit:

- (a) Voice announcements are inhibited below 500 feet above ground level (AGL).
- (b) The CANCEL BUTTON, halts voice announcements after the CANCEL BUTTON is activated. An aural advisory in progress is terminated and not repeated after deactivation of the CANCEL BUTTON.
- (c) During TCAS computer unit self-test, an aural advisory confirms proper operation of the aural advisory system by annunciating the message "TCAS TEST". The aural advisory system annunciates the pass/fail status of any monitored functions with the messages "TCAS TEST PASS" and "TCAS TEST FAIL", respectively.



## SYSTEM DESCRIPTION AND INSTALLATION MANUAL

### TCAS 3000 Traffic Alert and Collision Avoidance System

- (d) An aural advisory tone will precede each aural advisory when the audio tone enable program pin has been activated.
- (e) TCAS computer unit aural alerts are inhibited when the advisory inhibit discrete input No. 4 is grounded. An aural advisory in progress is disabled after the grounding of advisory inhibit discrete No. 4. The truncated message is annunciated in its entirety once the inhibit discrete has been released. This capability is used to defer all advisory (TA and RA), aural alert, and visual alert outputs until another, higher priority announcement/alert is completed.
- (f) Increases and decreases in the threat level are aurally annunciated. However, decreases in threat level are annunciated once and are not preceded by setting the audio tone discrete. For example, a vertical speed restriction following a climb RA is annunciated once.

#### (2) Traffic Advisory (TA) Message

The traffic advisory aural alert, TRAFFIC – TRAFFIC is spoken once, and then inhibited until the next TA occurs. This alert occurs when TCAS predicts an intruder will enter the collision area within 20 to 48 seconds. Simultaneously, the TCAS traffic display shows the location of the intruder.

#### (3) Resolution Advisory (RA) Messages

Resolution advisories indicate evasive vertical maneuvers calculated to increase separation between the TCAS aircraft and the intruder (corrective advisory), or to indicate certain changes in vertical speed are not recommended (preventive). Resolution advisory messages made up of a single word are repeated three times; longer messages are repeated twice.

RAs are annunciated on the TCAS computer unit using the voice messages listed below as determined by Collision Avoidance System (CAS) data. The following messages will not immediately follow another message from this paragraph if it causes a reversal of sense. For example, a “CLIMB, CLIMB, CLIMB” message cannot immediately follow a :”DESCEND, DESCEND, DESCEND” message.

- (a) “CLIMB, CLIMB, CLIMB”: Climb at the rate shown on the VSI or other suitable indicator. The –XX003 TCAS CU message is “CLIMB, CLIMB”.
- (b) “DESCEND, DESCEND, DESCEND”: Descend at the rate shown on the VSI or other suitable indicator. The –XX003 TCAS CU message is :”DESCEND, DESCEND”.
- (c) “MONITOR VERTICAL SPEED”: Verify that vertical speed is out of the illuminated red VSI arc, or comply with another suitable indicator. Additional messages are “MAINTAIN VERTICAL SPEED, MAINTAIN: MAINTAIN VERTICAL SPEED, CROSSING MAINTAIN”: or “ADJUST VERTICAL SPEED, ADJUST”. Safe separation is based upon maintaining the current vertical speed.
- (d) “ADJUST VERTICAL SPEED, ADJUST”: Reduce vertical speed to a speed out of the illuminated red arc.



## SYSTEM DESCRIPTION AND INSTALLATION MANUAL

TCAS 3000 Traffic Alert and Collision Avoidance System

- (e) “ADJUST VERTICAL SPEED, ADJUST”: Reduce vertical speed to a speed out of the illuminated red arc.
  - (f) “ADJUST VERTICAL SPEED, ADJUST”: Reduce climb or descent rate.
  - (g) “MAINTAIN VERTICAL SPEED, MAINTAIN”: Safe separation is based upon maintaining the current vertical speed.
  - (h) “MAINTAIN VERTICAL SPEED, CROSSING, MAINTAIN”: Maintain vertical speed while crossing the intruder’s flight path.
  - (i) “CLEAR OF CONFLICT”: Range is increasing, and separation is adequate; return to assigned clearance.
  - (j) “CLIMB, CROSSING CLIMB—CLIMB, CROSSING CLIMB”: Safe separation is best be achieved by climbing through intruder’s flight path.
  - (k) “DESCEND, CROSSING DESCEND, DESCEND, CROSSING DESCEND”: Safe separation is best achieved by descending through the intruder’s flight path.
- (4) Enhanced RA Messages

Enhanced RAs are annunciated on the TCAS computer unit using the voice messages listed below as designated by the CAS data when the initial resolution advisory does not provide sufficient vertical separation. These messages are annunciated to convey a sense of urgency. The following messages can immediately follow a message from the previous paragraph and have a reversal of sense.

**NOTE:** These advisories are expected to occur only on rare occasions, usually when an intruder suddenly changes its current flightpath. (Maneuvering intruder)

- (a) “INCREASE CLIMB, INCREASE CLIMB”: (Received after a “CLIMB” advisory) Indicates additional climb rate required to achieve safe vertical separation from a maneuvering intruder.
- (b) “INCREASE DESCENT, INCREASE DESCENT”: (Repeated two times, received after “DESCEND” advisory) Indicates additional descent rate required to achieve safe vertical separation from a maneuvering intruder.
- (c) “CLIMB, CLIMB NOW!—CLIMB, CLIMB NOW!”: (Received after a “DESCEND” resolution advisory) Indicates a reversal in sense is required to achieve safe vertical separation from a maneuvering intruder.
- (d) “DESCEND, DESCEND NOW!—DESCEND, DESCEND NOW!”: (Received after a “CLIMB” resolution advisory) Indicates a reversal in sense is required to achieve safe vertical separation from a maneuvering intruder.

### D. Operating Procedures

Basic TCAS operating procedures on the ground include pre-flight test, TCAS activation before takeoff, and TCAS deactivation after landing. In-flight procedures are contained in the pilot’s manual.



## SYSTEM DESCRIPTION AND INSTALLATION MANUAL

### TCAS 3000 Traffic Alert and Collision Avoidance System

#### (1) Pre-Flight Test

The VSI/TRA self-test feature provides a convenient method to test the TCAS system before takeoff.

**NOTE:** Self-test can be initiated at any time, on the ground or in flight (if not disabled in air by grounding pin RBP-8E), by momentarily pushing TCAS TEST. If TAs and RAs occur while self-test is activated in flight, the test aborts, and the advisories are processed and displayed.

To perform self-test, push the TCAS TEST button on the control panel and monitor the sequence that follows:

- Aural annunciation TCAS TEST is heard on audio system.
- Test pattern with fixed traffic and advisory symbols appears on the display for eight seconds.
- Make sure the test pattern is as shown in Figure 1-18. The test pattern includes:
  - An RA symbol at 3 o'clock, 2 nm, 200 ft above, in level flight
  - A TA symbol at 9 o'clock, 2 nm, 200 ft below, climbing
  - A proximate traffic symbol at 3.6 nm, 33 degrees right of the aircraft heading (approximately 1 o'clock), 1000 ft below, descending
  - A non-threat intruder (other traffic symbol) at 3.6 nm, 33 degrees left of the aircraft heading (approximately 11 o'clock), 1000 ft above, in level flight
  - Red and green resolution advisory VSI overlay indicating a don't descend, don't climb > 2000 ft/min advisory
  - TCAS TEST or RA OFF annunciation, depending on the capabilities of the display.
- After 8 seconds, TCAS TEST PASS is announced, and the test pattern is replaced with the normal VSI display.
- If self-test fails, TCAS TEST FAIL is announced, and TCAS FAIL appears on the display. To obtain failure data, perform the extended test mode procedure in the next section.



**SYSTEM DESCRIPTION AND INSTALLATION MANUAL**  
TCAS 3000 Traffic Alert and Collision Avoidance System

(2) TCAS Mode Activation

Prior to takeoff, activate TCAS as follows:

- Set TCAS/XPDR mode selector to TA/RA
- Set TA/DSPLY to AUTO
- Set ALT/RPTG to 1 or 2.

(3) TCAS Mode Deactivation

After clearing the runway following landing, set the TCAS/XPDR mode selector to STBY to disable Mode S communication.

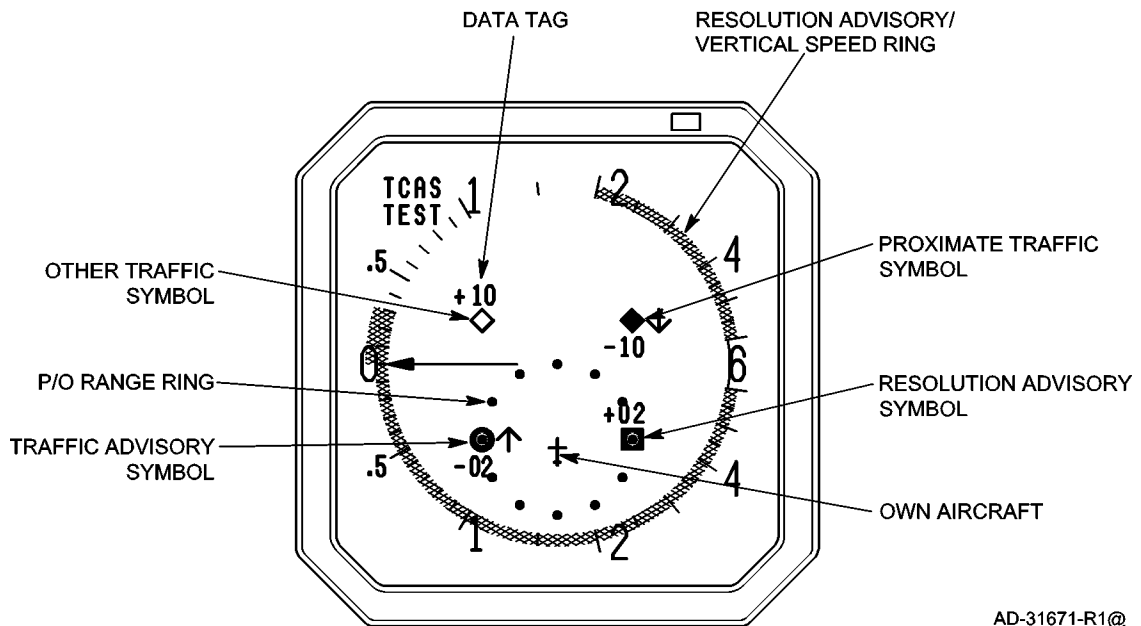

**Figure 1-18. TCAS II Display Test Pattern**



**SYSTEM DESCRIPTION AND INSTALLATION MANUAL**  
TCAS 3000 Traffic Alert and Collision Avoidance System

## **MECHANICAL INSTALLATION**

### **1. General**

This section contains information on how and where to mount each component of the TCAS 3000 system. For new installations, plan installation in two stages. First, determine location of the LRUs in the aircraft. Next, determine the length of RF and electrical interconnections for selected locations.

**NOTE:** The TCAS 3000 LRU, ACSS Part No. 9003000-10XXX can functionally replace a TCAS 2000 LRU, Part No. 4066010-904, -905, or -907, in existing installations. Certification approval must be obtained.  
TCAS 2000 LRUs, Part No. 4066010-904, -905, -907, -910, or 7517900-10XXX may replace the TCAS 3000 if properly demonstrated and certified.

### **2. Equipment and Materials**

For new TCAS 3000 installations, refer to Table 1-1 for RCZ-852 Transponder Installation Kit information and Table 1-2 for mounting tray information. For all other components, refer to the applicable Outline and Installation drawing in this section for mounting information. The Outline and Installation drawings show connector and connector contact pin/socket part number information, where applicable.

### **3. Mechanical Installation Design**

**NOTE:** To assure proper grounding of the TCAS 3000 system, the aircraft surface to which all mountings or units are attached must be clean bare metal. Mount to the airframe with a resistance of 5 milliohms or less.

#### **A. TCAS 3000 Computer Unit Provisions**

Mechanical installation data for the TCAS 3000 Computer Unit (6-MCU) is shown in Figure 2-1. Data for the TCAS 3000 Computer Unit (4-MCU) is shown in Figure 2-2.

The computer unit can be mounted in any convenient location in the aircraft; however, it must be located so as to maintain an antenna coaxial cable insertion loss of  $2.5 \pm 0.5$  dB in accordance with DO-185. This is approximately within 50 feet of the antenna unless low loss coaxial cable is used. Top and bottom coaxial delay timing differences can be compensated for by use of the antenna delay program pins.

The TCAS Computer Unit, Part No. 9003000-10XXX, is mounted in an ARINC 600 6-MCU mounting tray. The computer unit requires external cooling air in accordance with ARINC 600 or ARINC 404 to maintain the highest possible Mean Time Between Failures (MTBF). In those installations where this is not available, a mounting tray with an integral fan is required.

The TCAS Computer Unit, Part No. 9003000-55XXX or 65XXX, is mounted in an ARINC 600 4-MCU mounting tray. This unit contains an internal temperature controlled fan, so it does not require any external cooling.





## SYSTEM DESCRIPTION AND INSTALLATION MANUAL

### TCAS 3000 Traffic Alert and Collision Avoidance System

#### B. Antenna Provisions

The TCAS top directional antenna should, ideally, be the most forward antenna on the top of the aircraft and should be located as close to the longitudinal centerline as possible. See Figure 2-4. A 5-degree tilt angle is allowed laterally, with 2-degree positive and 5-degree negative tilt angles allowed longitudinally. See Figure 2-5.

If a bottom directional antenna is used, it should also be the most forward antenna on the fuselage bottom. Tilt angle allowances are the same as on the top antenna. A bottom omnidirectional antenna need not be the most forward antenna, but it should be separated by at least 20-inches from any other L-band antenna.

Since the bottom antenna may be either a directional (standard) or an omnidirectional (optional) antenna, dual notation is shown in the wiring diagram. Only one coax cable is needed for an omnidirectional antenna installation.

##### (1) Directional Antenna Installation

The top directional antenna mounting and installation data is given in Figure 2-6. Figure 2-6 contains the maximum radius dimensions for the various curved antenna base part number units, the number of aircraft mounting holes and the length of the connector extension for the various part number units. The antenna must be electrically bonded (less than 5.0 milliohms bonding resistance) to the airframe to provide a good ground contact for lightning protection.

The directional antenna must be separated by a least 30-inches from any other L-band antenna, and 60-inches is preferred. If a bottom directional antenna is used, it should be the most forward antenna on the fuselage bottom with tilt angle allowances the same as for a top mounted antenna.

An O-ring (included with the directional antenna) is required to be installed between the directional antenna and the aircraft fuselage. The Navy Aeronautical Standard part number for the O-ring is NAS 1611-240. The ACSS part number for the O-ring is 4000171-240.

**NOTE:** For directional antennas, ACSS Part No. 7514060-90X, the customer must provide an adapter plate for mounting to the aircraft. The antenna base plate, to which the adapter must mate, is detailed in Figure 2-7. Directional antennas, ACSS Part No. 7514081-9XX, come with a preinstalled adapter plate.

##### (2) Omnidirectional Antenna Installation

The bottom omnidirectional antenna is a standard ATC type antenna. It should be qualified to TSO C119a and be dc grounded per MIL-A-90941, B-5087B. All L-band antennas must be separated by at least 20-inches. Only one coax cable is required for installation.

The omnidirectional antenna is not supplied by ACSS. To install, follow the manufacturer's installation instructions.





**SYSTEM DESCRIPTION AND INSTALLATION MANUAL**  
TCAS 3000 Traffic Alert and Collision Avoidance System

**C. Control Panel Provisions**

Mechanical installation data for the ACSS ATC/TCAS Control Panels is shown in Figure 2-8 and Figure 2-9. The control panel is supplied in either a dual Mode S/TCAS configuration shown in Figure 2-8, or an ATRBS-Mode S/TCAS configuration shown in Figure 2-9.

Mechanical installation data a typical Gables GXXXX Series ATC/TCAS control panel is shown in Figure 2-10.

It should be noted that various other types of controllers (Radio Management Units or EFIS Display Controllers) can be used to control the TCAS display. If a controller other than a ACSS ATC/TCAS control panel is used, refer to that particular unit's manual for installation data.

**D. VSI/TRA Provisions**

Mechanical installation data for the ACSS VSI/TRA display is shown in Figure 2-11. The VSI/TRA is usually used as a direct replacement for the existing 3-ATI form VSI indicator currently mounted in the cockpit. Replacement of the installation clamp may be necessary if the previous clamp is less than 2-inches deep. Some older aircraft clamps do not provide sufficient mechanical support.

If a ACSS VSI/TRA is used as the TCAS display source, and an Air Data Computer is not available to provide vertical speed signals to the display, the installation must include a ACSS PTM to supply air data signals to the VSI/TRA. These signals are derived from a static pneumatic input.

**E. Pressure Transducer Module (PTM) Provisions**

Mechanical installation data for the PTM is shown in Figure 2-12. The PTM is configured to be mounted on a mounting bracket designed for use in a restricted access area or on a mounting plate for mounting in an ARINC 408A 3ATI round instrument panel space.

The PTM is conduction, radiation, and natural convection cooled. It does not require any external cooling as long as it is installed in a pressurized area where the ambient temperature is within the established temperature range of the device.



**SYSTEM DESCRIPTION AND INSTALLATION MANUAL**  
TCAS 3000 Traffic Alert and Collision Avoidance System

**F. Transponder Provisions**

This paragraph contains the mechanical installation data for the ACSS Mode S Data Link Transponder, Part No. 7517800-XXYYY and ACSS Diversity Mode S Transponder, Part No. 7510700-850/-951. It also contains provisions for installing the ATC transponder antennas.

(1) Mode S Data Link Transponder Provisions

Mechanical installation data for the ACSS Mode S Data Link Transponder, Part No. 7517800-XXYYY is shown in Figure 2-13. The transponder can be mounted in any convenient location in the aircraft; however, it should be mounted within 30 feet of the antennas unless low loss coaxial cable is used to maintain a worst case loss of 3dB per ARINC 718-A. Top and bottom antenna coaxial run length differences can be compensated for by use of the antenna delay program pins on the transponder. The unit can utilize external cooling air in accordance with ARINC 600 or ARINC 404 or operate in convection-cooled environments. The transponder is mounted in an ARINC 600 4-MCU tray assembly.

(2) Diversity Mode S Transponder Provisions

Mechanical installation data for the ACSS RCZ-852 Diversity Mode S Transponder, Part No. 7510700-850/-951 is shown in Figure 2-14. The transponder can be mounted in any convenient location in the aircraft that allows the unit to be upright during normal flight. The exact location should allow the cabling between the unit, control panel, and antennas to be as short as possible. The location of the mounting tray (part of installation kit, Part No. 7510707-968) should allow adequate space for installation of the transponder, provide reasonable accessibility for servicing, and allow space on top, sides, and rear of unit for adequate ventilation. The location must also provide a solid mechanical mount to prevent vibration amplification. The mounting tray should be electrically bonded to the aircraft frame by a low resistance path of less than 2.5 milliohms.

(3) ATC Transponder Antenna Provisions

When installing transponder antennas, a TSO'd antenna should be selected. The antenna must be vertically polarized and operate in the frequency range of 960 to 1220 MHz. Antenna impedance must be 50 ohms. Voltage standing wave ratio (VSWR) shall not exceed 1.5:1. Selection of a grounded or lightning protected type antenna is required to pass the transponder bite continuity detection circuitry, if enabled.

In dual transponder antenna installations it is important to provide adequate isolation from each other to prevent receiver front-end damage. A 20-inch minimum separation of Mode S antennas from other L-Band antennas, including TCAS antennas, must be maintained. The maximum cable length for RG-214/U is 30 feet (9.144 meters). Allow adequate cable length so bends in cable have a minimum 3-inch (76 mm) radius. Selection of coax cable assemblies with moisture barrier protection is highly recommended to minimize the effects of humidity and corrosion.



## **SYSTEM DESCRIPTION AND INSTALLATION MANUAL**

TCAS 3000 Traffic Alert and Collision Avoidance System

When you install ATC antennas, the mounting area must provide a solid mechanical base for the antenna as well as clearance for the connector. A doubler plate is usually required when the antenna is mounted on an unsupported large fuselage area. Never weaken aircraft structure for the sake of a good location. Refer to the aircraft manufacturer's specifications; reinforcements for antennas are often built into the aircraft structure.

Doubler plates or shims, if used, must be metallic and shaped to interface the antenna base with the contour of the aircraft fuselage. ATC antennas are not supplied by ACSS. All antenna installations should be in accordance with manufacturer installation instructions.

A weather sealant should be applied around the periphery of the antenna base to prevent seepage of water and condensation and preclude corrosion. If a sealant or aerodynamic smoother is used, it should be applied after the antenna has been bolted down.



**SYSTEM DESCRIPTION AND INSTALLATION MANUAL**  
TCAS 3000 Traffic Alert and Collision Avoidance System

Blank Page



**SYSTEM DESCRIPTION AND INSTALLATION MANUAL**  
 TCAS 3000 Traffic Alert and Collision Avoidance System

NOTES:

1. UNIT WEIGHT:  
 UNIT PART NUMBER 9003000-10001 (AC/DC UNIT)  
 NOMINAL 15.61 POUNDS/MAXIMUM 16.08 POUNDS (7.08/7.29 KILOGRAMS).
2. DENOTES APPROXIMATE CENTER OF GRAVITY.
3. DARKENED PORTION INDICATES SOLID PART OF POLARIZING KEYWAY.
4. THE INSTALLATION IS IN ACCORDANCE WITH ARINC 600 6 MCU.
5. DIMENSIONS ARE IN INCHES. SEE METRIC CONVERSION TABLE FOR CORRESPONDING DIMENSIONS IN MILLIMETERS.
6. THE UNIT MAY ACCEPT EITHER BLOW-THRU COOLING PER ARINC 600 OR DRAW-THRU COOLING PER ARINC 404. THE NORMAL OPERATION COOLING AIRFLOW REQUIREMENT PER ARINC 600 IS 485 POUNDS PER HOUR PER KILOWATTS (220 KILOGRAMS/HOUR-KILOWATTS). AT EITHER OF THE AIRFLOW RATES, THE PRESSURE DROP THROUGH THE UNIT IS .20±.12 INCHES OF WATER (5±3 MILLIMETERS OF WATER).
7. UNIT FINISH: CHEM FILM TREATED OVER BARE ALUMINUM.
8. .10 MAX REAR PANEL THICKNESS IS REQUIRED IN CONNECTOR MOUNTING AREA DEFINED AS ZONE A. NO OTHER PROJECTIONS EXCEPT CONNECTOR MOUNTING HARDWARE ARE PERMITTED IN AREA DEFINED AS ZONE A.
9. INFORMATION CONTAINED IN THIS DRAWING IS INTENDED FOR INSTALLATION USE ONLY. IT IS NOT TO BE USED FOR DESIGN OR MANUFACTURING PURPOSES.
10. THIS DRAWING DEFINES END ITEM UNIT 9003001-10XXX  
 XXX = SOFTWARE CONFIGURATION FROM 001 THRU 999, AS DEFINED IN THE END ITEM DRAWING.
11. TYPICAL POWER DISSIPATION IS 85 WATTS
12. THE DIMENSION SHOWN IS TO THE CONNECTOR BOSS AND NOT THE REAR PANEL OPENING.

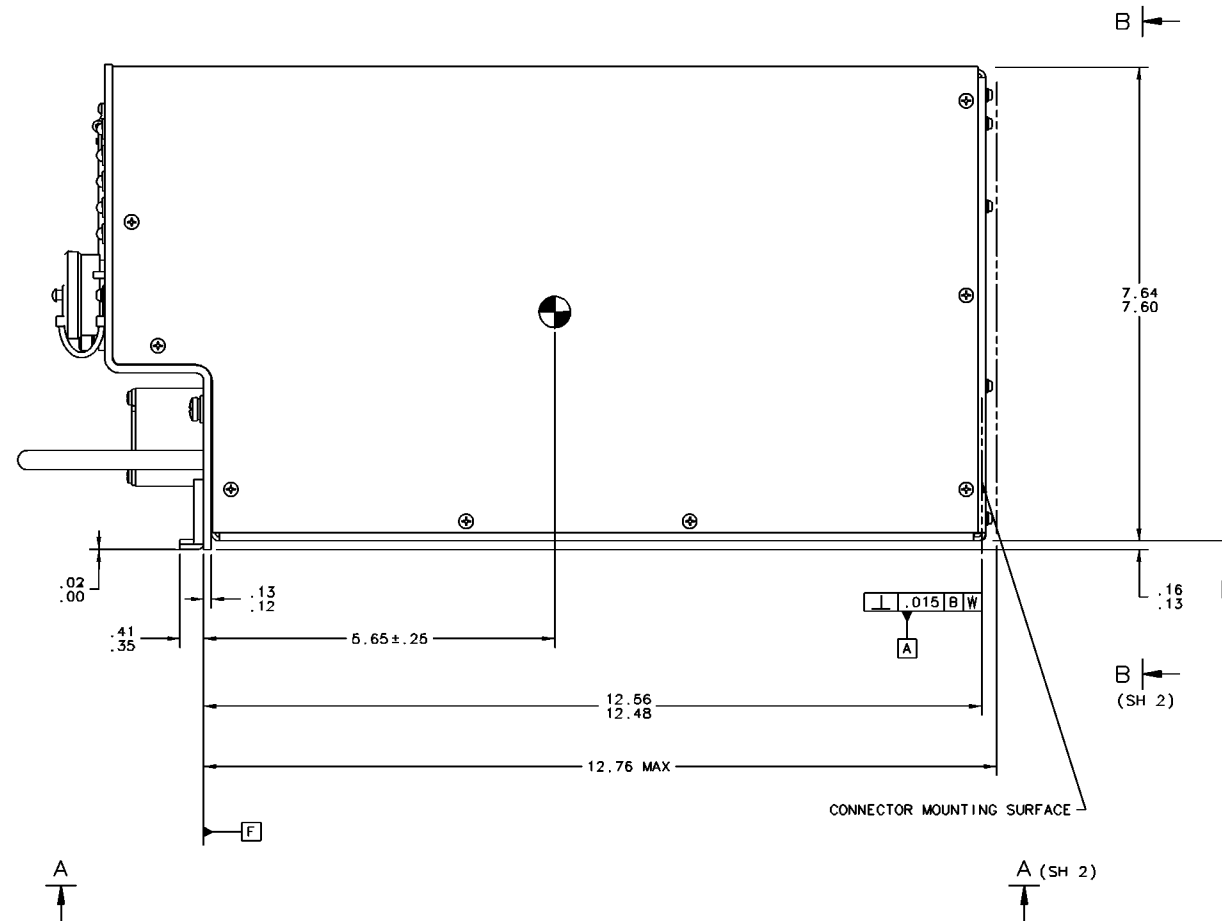
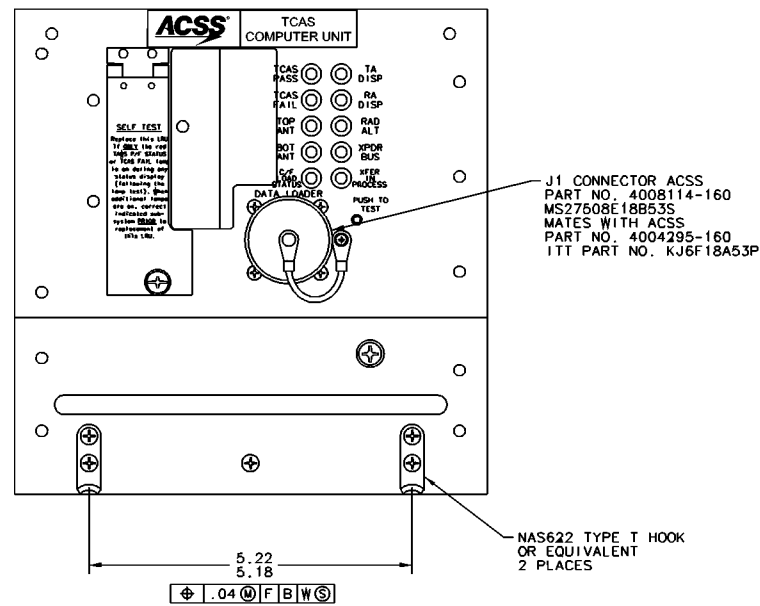
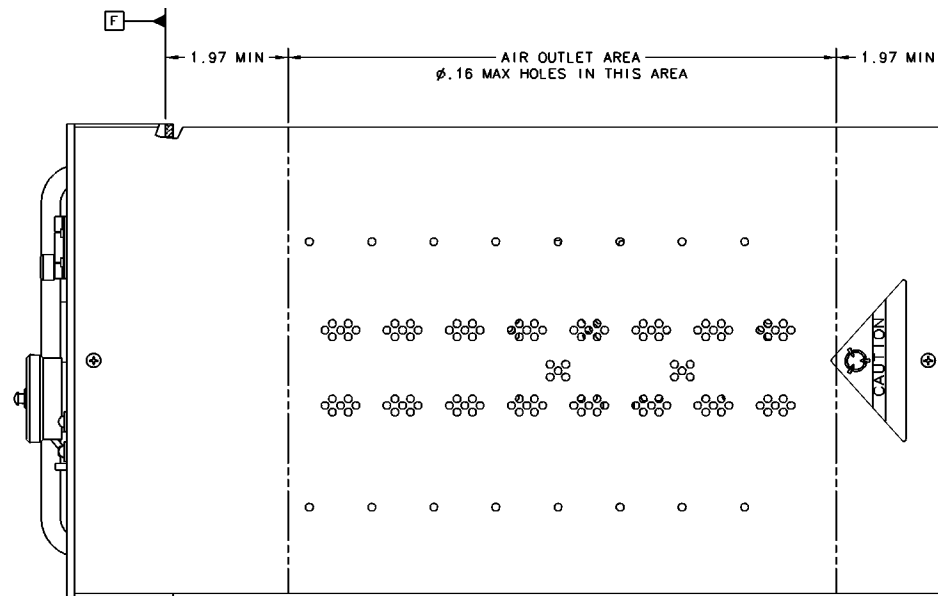

ID-8005646-001

Figure 2-1 (Sheet 1). TCAS 3000 Computer Unit Outline and Installation Drawing



**SYSTEM DESCRIPTION AND INSTALLATION MANUAL**  
 TCAS 3000 Traffic Alert and Collision Avoidance System

CONVERSION TABLE	
INCHES	MILLIMETERS
.010	0.25
.015	0.38
.02	0.51
.025	0.64
.04	1.02
.06	1.52
.08	2.03
.10	2.54
.12	3.05
.13	3.30
.16	4.06
.186	4.72
.25	6.35
.35	8.89
.41	10.41
1.40	35.56
1.542	39.17
1.728	43.89
1.97	50.04
2.50	63.50
3.68	93.47
3.90	99.06
4.50	114.30
5.18	131.57
5.20	132.08
5.22	132.59
5.65	143.51
6.89	175.01
7.48	189.99
7.52	191.01
7.60	193.04
7.64	194.06
11.30	287.02
12.48	316.99
12.56	319.02
12.76	324.10

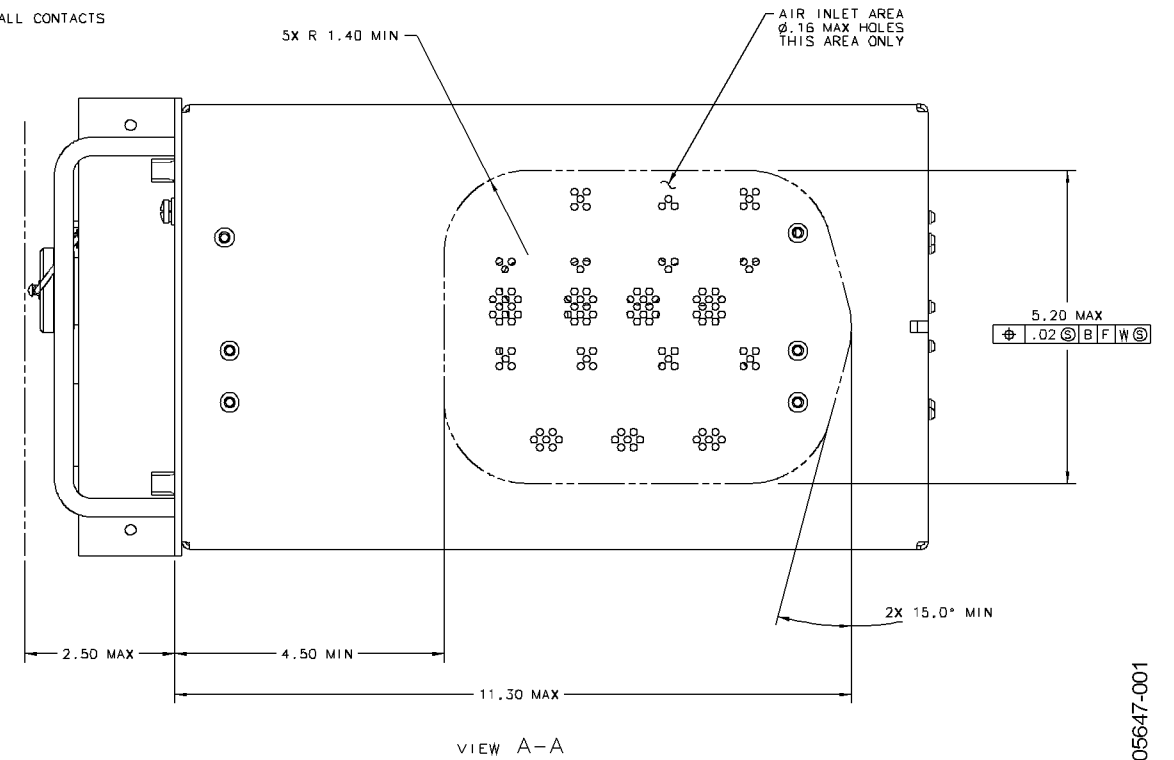
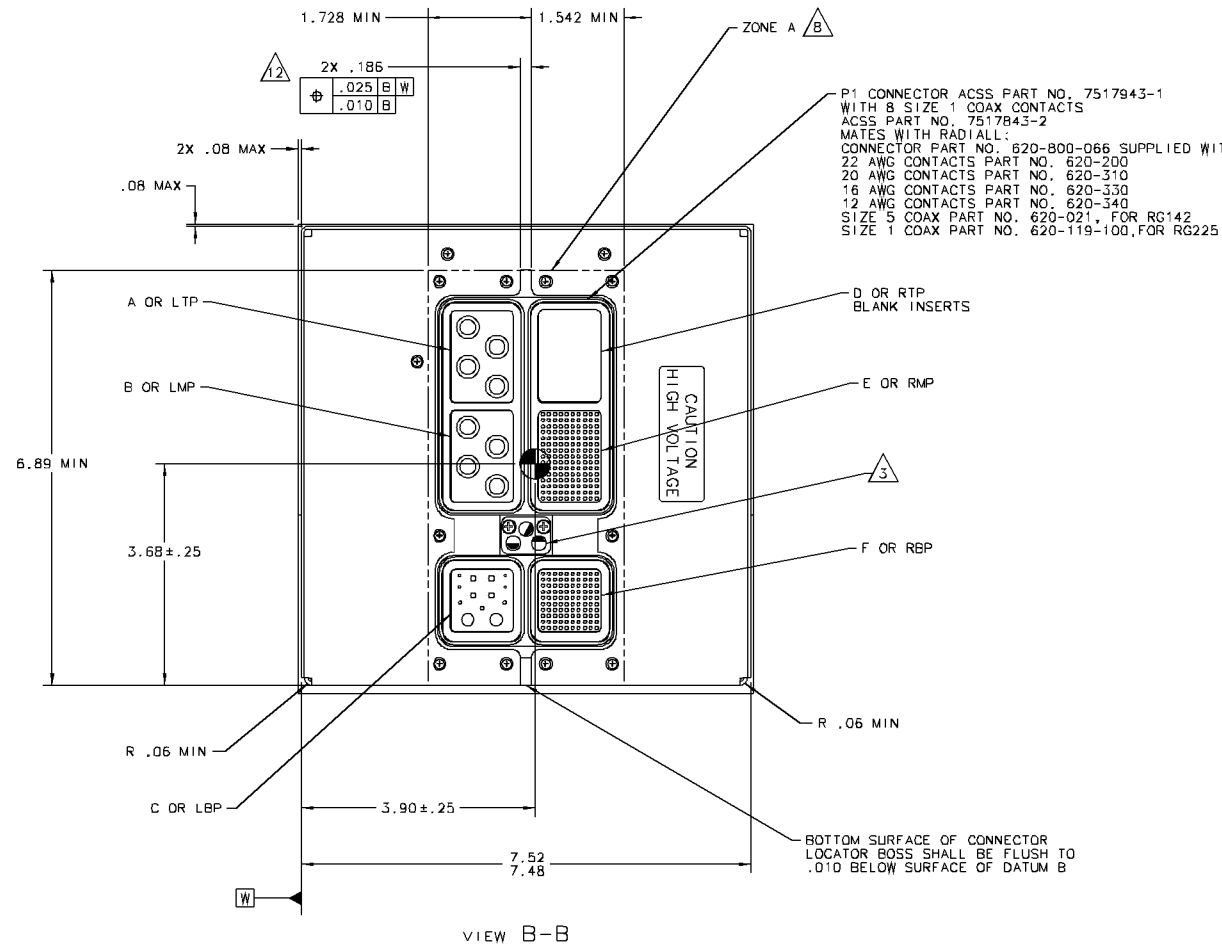

Figure 2-1 (Sheet 2). TCAS 3000 Computer Unit Outline and Installation Drawing





**SYSTEM DESCRIPTION AND INSTALLATION MANUAL**  
 TCAS 3000 Traffic Alert and Collision Avoidance System

CONVERSION TABLE	
INCHES	MILLIMETERS
.010	.254
.015	.381
.02	.51
.025	.635
.04	1.02
.06	1.52
.08	2.03
.10	2.54
.12	3.05
.13	3.30
.16	4.06
.186	4.72
.25	6.35
.35	8.89
.41	10.41
.43	10.92
.46	11.68
.50	12.70
.54	13.72
.55	13.97
1.542	39.17
1.728	43.89
2.58	65.53
2.60	66.04
2.62	66.55
3.03	76.96
3.95	100.33
4.86	123.44
4.90	124.46
5.69	144.53
6.21	157.73
6.29	159.77
6.72	170.69
6.84	173.74
6.89	175.01
7.60	193.04
7.64	194.06
11.21	284.73
11.29	286.77
12.48	316.99
12.56	319.02
12.76	324.10
12.96	329.18
13.04	331.22

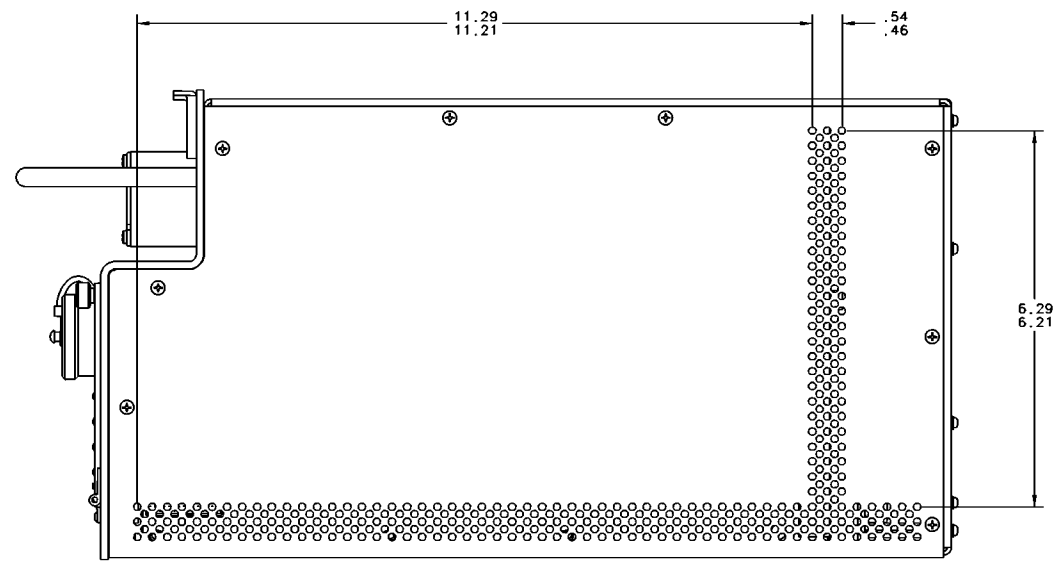

VIEW C-C

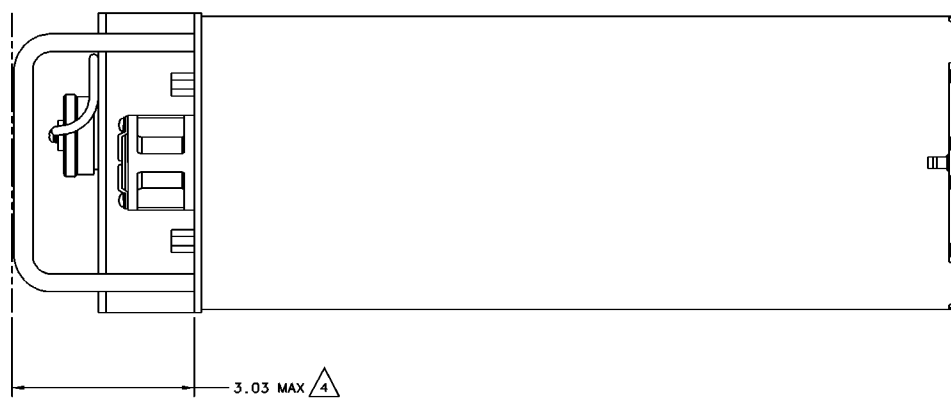

VIEW A-A

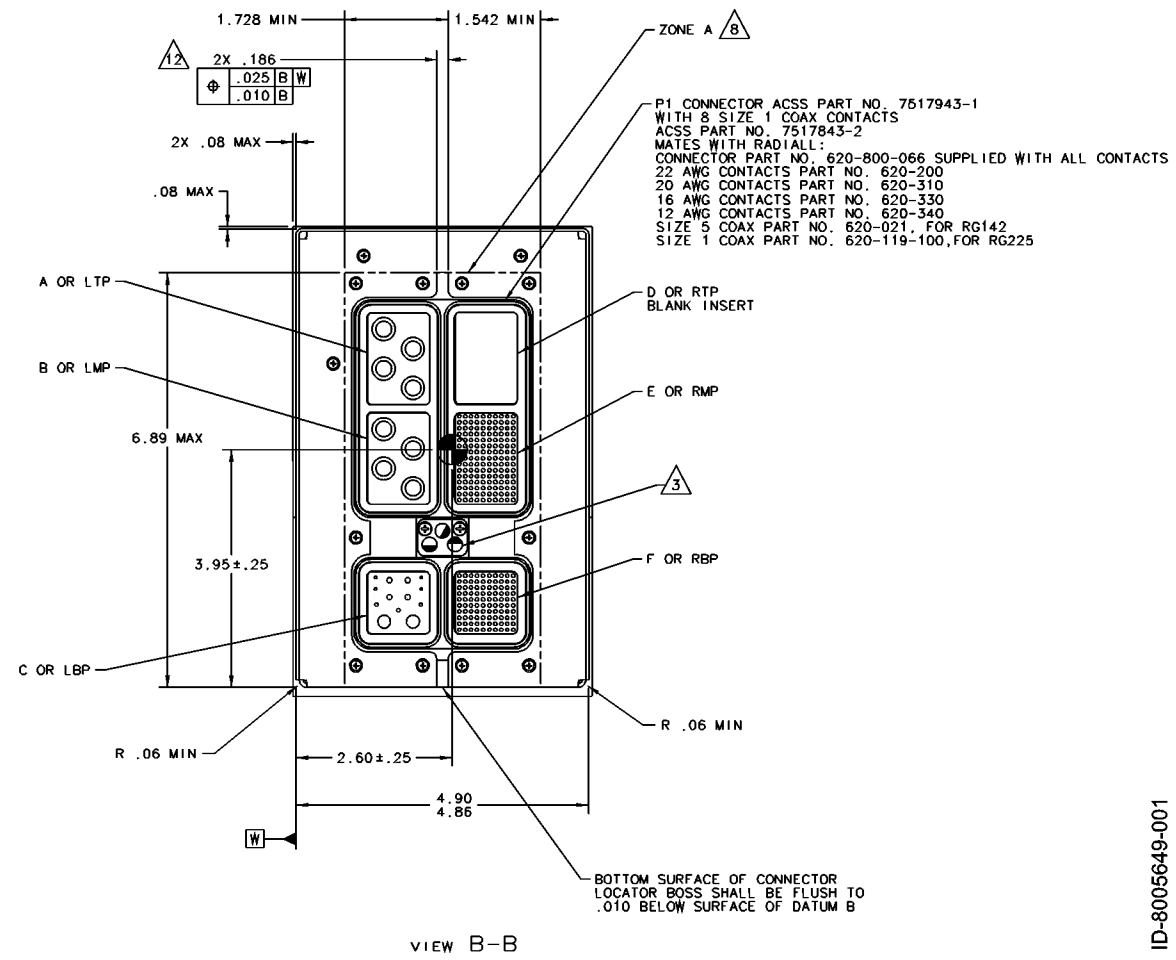

VIEW B-B

Figure 2-2 (Sheet 2). TCAS 3000 Computer Unit Outline and Installation Diagram







**SYSTEM DESCRIPTION AND INSTALLATION MANUAL**  
 TCAS 3000 Traffic Alert and Collision Avoidance System

CONVERSION TABLE	
INCHES	MILLIMETERS
.010	.254
.015	.381
.02	.51
.025	.635
.04	1.02
.06	1.52
.08	2.03
.10	2.54
.12	3.05
.13	3.30
.16	4.06
.186	4.72
.25	6.35
.35	8.89
.41	10.41
.43	10.92
.46	11.68
.50	12.70
.54	13.72
.55	13.97
1.542	39.17
1.728	43.89
2.50	63.50
2.58	65.53
2.62	66.55
3.03	76.96
3.78	96.01
4.86	123.44
4.90	124.46
5.72	145.29
6.21	157.73
6.29	159.77
6.72	170.69
6.84	173.74
6.89	175.01
7.60	193.04
7.64	194.06
11.21	284.73
11.29	286.77
12.48	316.99
12.56	319.02
12.76	324.10
12.96	329.18
13.04	331.22

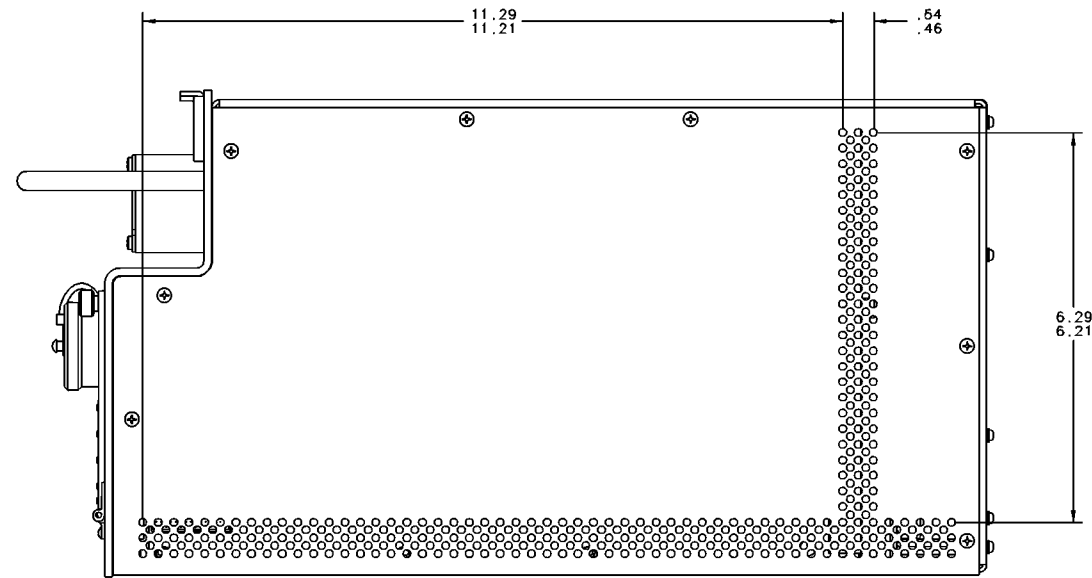

VIEW C-C

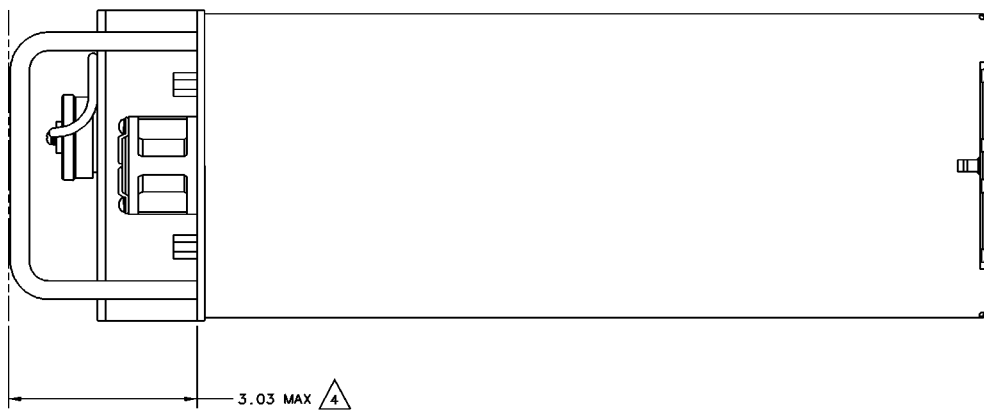

VIEW A-A

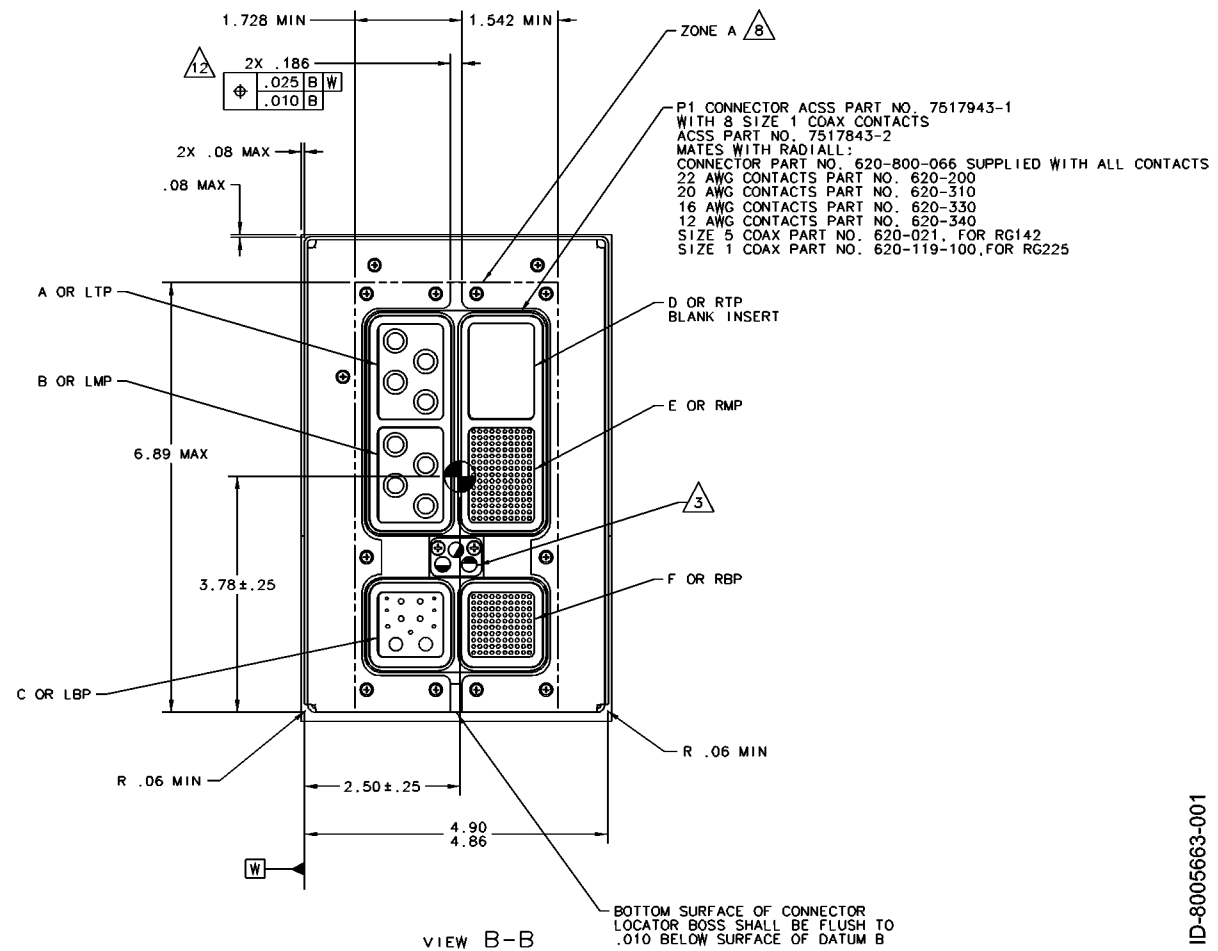

VIEW B-B

Figure 2-3 (Sheet 2). TCAS 3000 Computer Unit Outline and Installation Diagram



**SYSTEM DESCRIPTION AND INSTALLATION MANUAL**  
TCAS 3000 Traffic Alert and Collision Avoidance System

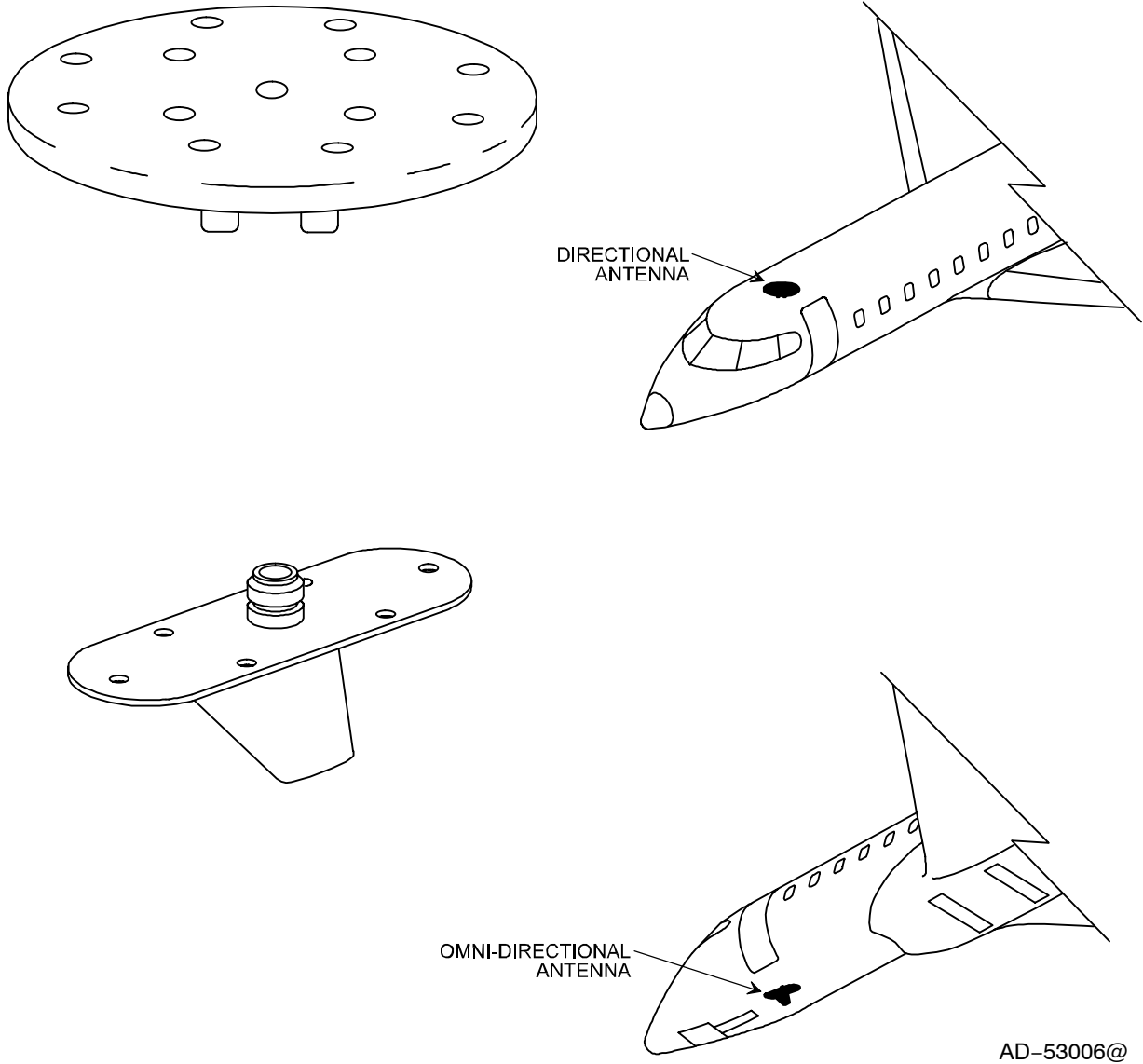
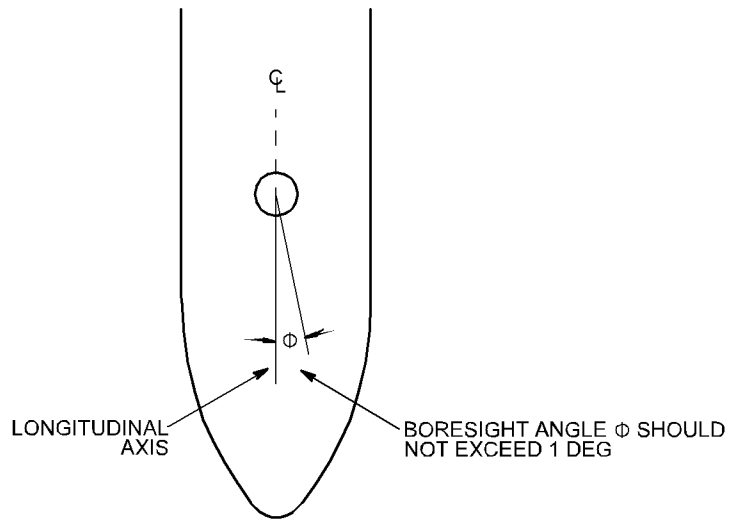
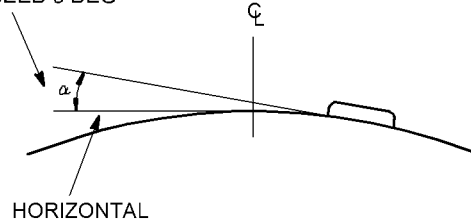

**Figure 2-4. TCAS Directional and Omnidirectional Antenna Locations**



**SYSTEM DESCRIPTION AND INSTALLATION MANUAL**  
TCAS 3000 Traffic Alert and Collision Avoidance System

LATERAL DEVIATION  $\alpha$  SHOULD NOT EXCEED 5 DEG



NOTE: STATED ANGLES REPRESENT ACSS RECOMMENDATIONS BASED UPON NOMINAL ANTENNA COVERAGE OVERLAP AND ANTICIPATED INSTALLATION PROCESSES.

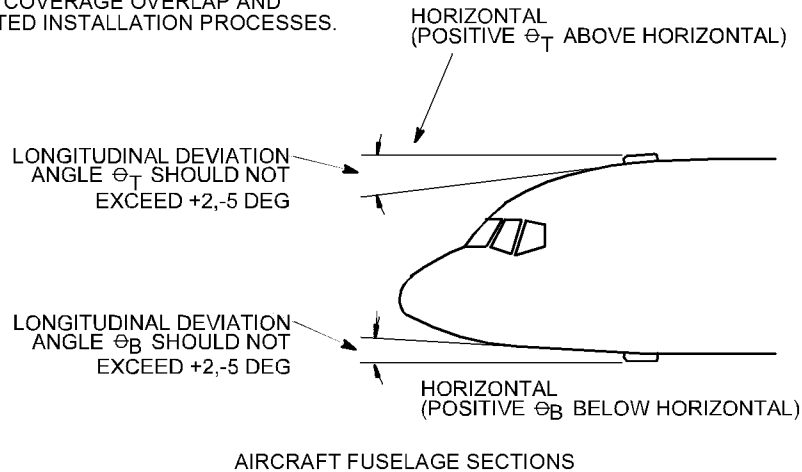



ID-8005664-001

**Figure 2-5. Directional Antenna Angular Orientation**



**SYSTEM DESCRIPTION AND INSTALLATION MANUAL**  
TCAS 3000 Traffic Alert and Collision Avoidance System

NOTES:

1.  DENOTES APPROXIMATE CENTER OF GRAVITY.
2. FOR MAXIMUM UNIT WEIGHT, REFER TO TABLES 3 AND 4.
3. DIMENSIONS SHOWN ARE IN INCHES. REFER TO METRIC CONVERSION TABLE FOR CORRESPONDING DIMENSIONS IN MILLIMETERS.
4.  .
5.  INDICATED ASSEMBLY INCLUDES A .015 INCH (.381 MILLIMETER) TEFLON GASKET FOR PLACEMENT BETWEEN THE ANTENNA/ADAPTER ASSEMBLY AND THE AIRCRAFT.
6.  THE SOLID SQUARE SYMBOL DENOTES A CRITICAL PARAMETER. THE NUMBER IN THE CENTER CORRESPONDS TO THE FOLLOWING SUB-NOTE WITH THE SAME NUMBER, STATING TYPE AND NATURE OF CRITICALITY.
   
  
 INSTALLATION CRITICAL – COMPLIANCE WITH CRITICAL INSTALLATION REQUIREMENTS IS NECESSARY WHEN UTILIZING EITHER AN ACSS OR CUSTOMER SUPPLIED ADAPTER PLATE.
7. MOUNTING SCREWS (NOT SUPPLIED) SHALL BE STANDARD 10-32 UNF-2A PANHEAD CORROSION RESISTING (STAINLESS) STEEL SCREWS PER MILITARY SPECIFICATION MS51958. APPROPRIATE LENGTH WILL BE DETERMINED BY THE INSTALLER ALLOWING 0.5 INCHES FOR THE THICKNESS OF THE ANTENNA AND ADAPTER PLATE. A WASHER SHALL BE INSTALLED UNDER THE HEAD OF EACH MOUNTING SCREW. THE WASHER SHALL BE MADE OF PASSIVATED CORROSION RESISTANT STEEL PER MIL-S-5059 OR MIL-S-6721. THE AIR FORCE-NAVY AERONAUTICAL STANDARD PART NUMBER FOR THE WASHER IS AN960C10L. MOUNTING SCREWS ARE RECOMMENDED TO BE PHILLIPS TYPE TO EASILY DIFFERENTIATE BETWEEN INSTALLER PROVIDED MOUNTING SCREWS AND TORX SCREWS PERMANENTLY INSTALLED BY THE MANUFACTURER.
8. THE MOUNTING SCREWS SHALL BE TIGHTENED TO A TORQUE OF 22 ± 3 INCH-POUNDS (1.8 ± 0.2 FOOT-POUNDS OR 2.5 ± 0.3 NEWTON-METERS).
9. FOR INSTALLATIONS OF ANTENNAS WITH FLAT ADAPTER PLATES (PN 7514081-901, 7514081-902, 7514081-910, 7514081-913), THE SURFACE OF THE AIRCRAFT ADAPTER PLATE TO WHICH THE ANTENNA WILL MATE, IS RECOMMENDED TO BE FLAT WITHIN 0.010 INCHES.
10. MOUNTING SCREWS MUST BE USED TO SECURE THE ANTENNA TO THE AIRCRAFT AT EVERY CLEARANCE HOLE THROUGH THE ANTENNA. REFER TO TABLES 3 AND 4 FOR REQUIRED NUMBER OF AIRCRAFT MOUNTING SCREWS.
11. ALL 7514060 ANTENNAS (WHICH UTILIZE CUSTOMER PROVIDED ADAPTER PLATES) ARE SHIPPED FROM THE MANUFACTURER WITH 12 OPEN SCREW HOLES OF WHICH ALL MUST BE FILLED WITH SCREWS. EITHER FOUR OR EIGHT SCREWS MUST BE USED TO MOUNT THE ANTENNA TO THE AIRCRAFT (SEE PAGE 5 FOR MOUNTING CONFIGURATION). THE ANTENNA MUST BE SECURED TO EITHER THE ANTENNA ADAPTER PLATE OR AIRCRAFT ADAPTER/DOUBLER WITH SCREWS AT EVERY REMAINING ANTENNA CLEARANCE HOLE (EIGHT OR FOUR RESPECTIVELY) THAT IS NOT USED TO MOUNT THE ANTENNA TO THE AIRCRAFT.
12. THE TCAS DIRECTIONAL ANTENNA COMPLIES WITH THE MOUNTING FOOTPRINT OPTIONS SPECIFIED IN RTCA DO-185A.

METRIC CONVERSION TABLE	
INCHES	MILLIMETERS
.010	.254
.028	.71
.238	6.05
.244	6.20
.250	6.35
.360	9.14
.395	10.03
.600	15.24
.705	17.91
.806	20.47
1.560	39.62
1.900	48.26
2.900	73.66
3.000	76.20
5.000	127.00
7.375	187.33
9.310	236.47
42.0	1066.8
44.80	1137.92
61.52	1562.6
66.52	1689.6
74.02	1880.1
77.78	1975.6
85.06	2160.5
99.02	2515.1
111.02	2819.9
118.52	3010.4

**Figure 2-6 (Sheet 1). Directional Antenna Outline and Installation Diagram**



**SYSTEM DESCRIPTION AND INSTALLATION MANUAL**  
TCAS 3000 Traffic Alert and Collision Avoidance System

TABLE 1	
REF DES	SLEEVING COLOR
J1	YELLOW
J2	BLACK
J3	BLUE
J4	RED

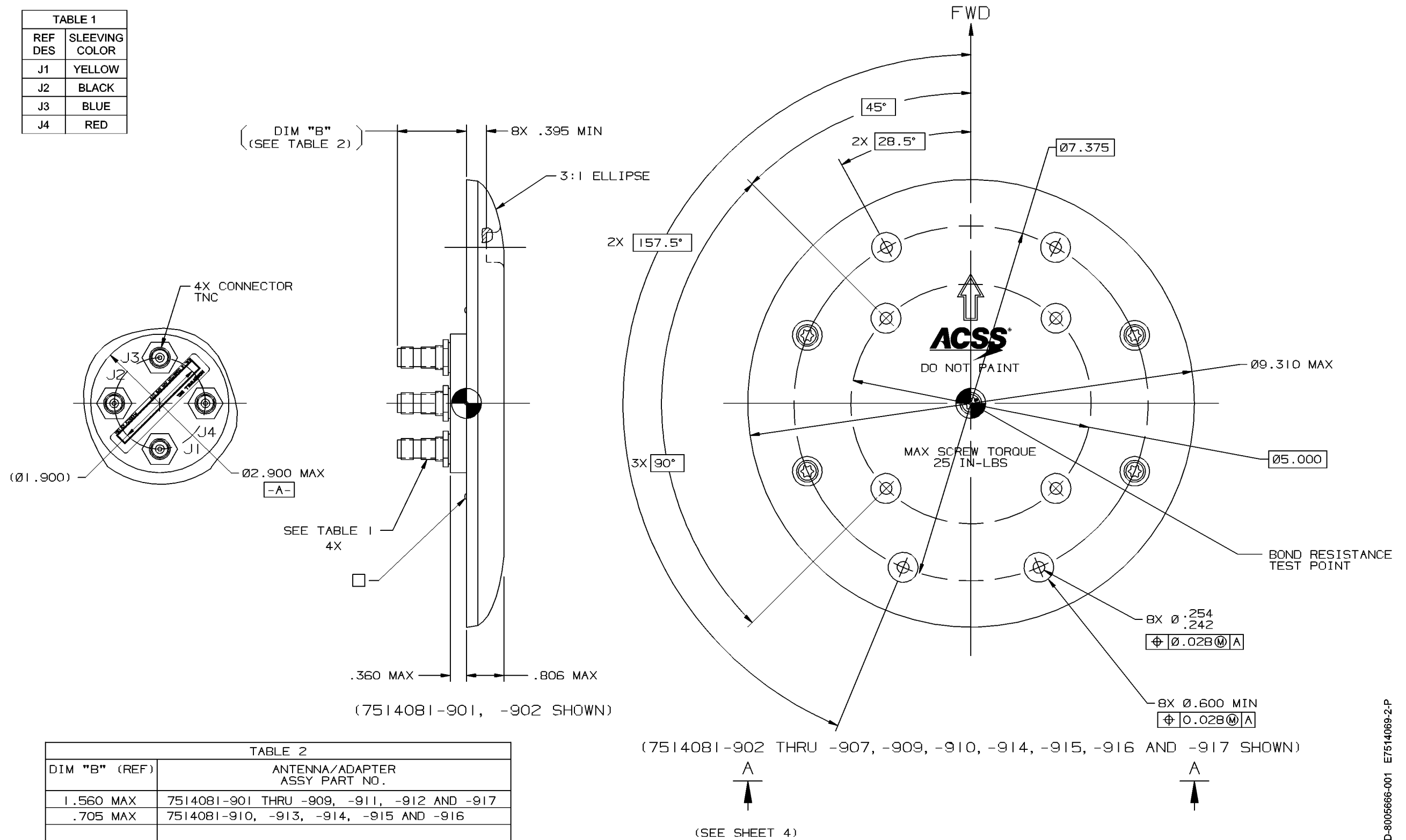

Figure 2-6 (Sheet 2). Directional Antenna Outline and Installation Diagram



**SYSTEM DESCRIPTION AND INSTALLATION MANUAL**  
 TCAS 3000 Traffic Alert and Collision Avoidance System

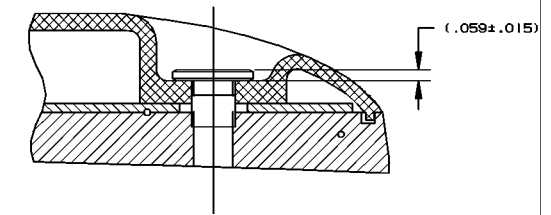
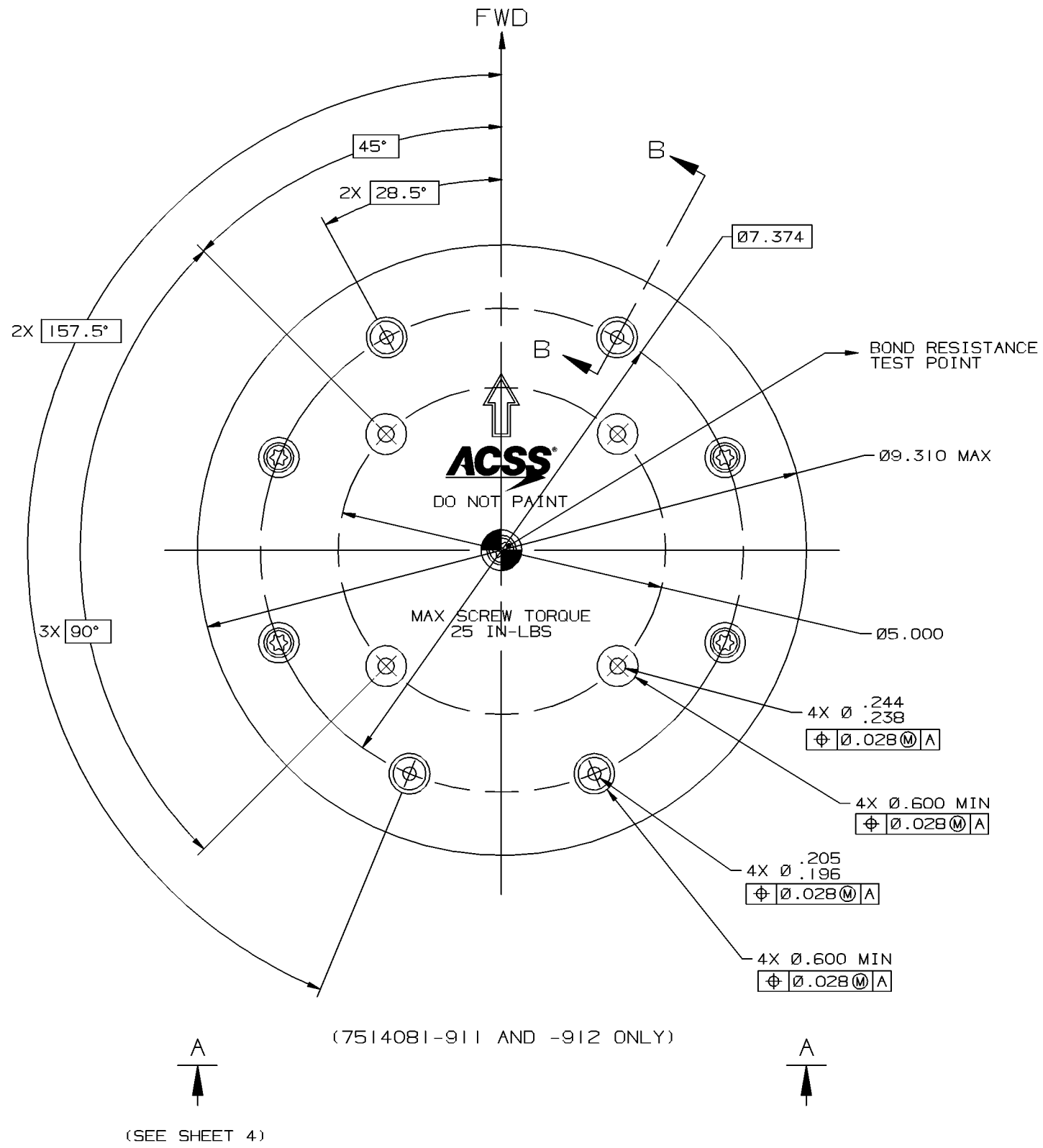

Figure 2-6 (Sheet 3). Directional Antenna Outline and Installation Diagram

**34-43-23**

ID-8005667-001 E7514069-3-K



**SYSTEM DESCRIPTION AND INSTALLATION MANUAL**  
TCAS 3000 Traffic Alert and Collision Avoidance System

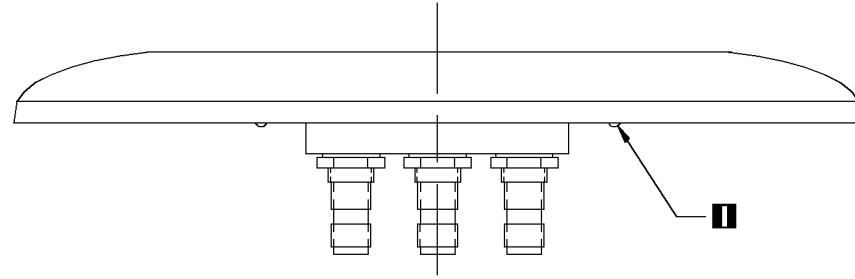

VIEW A-A  
(SEE TABLE 3)

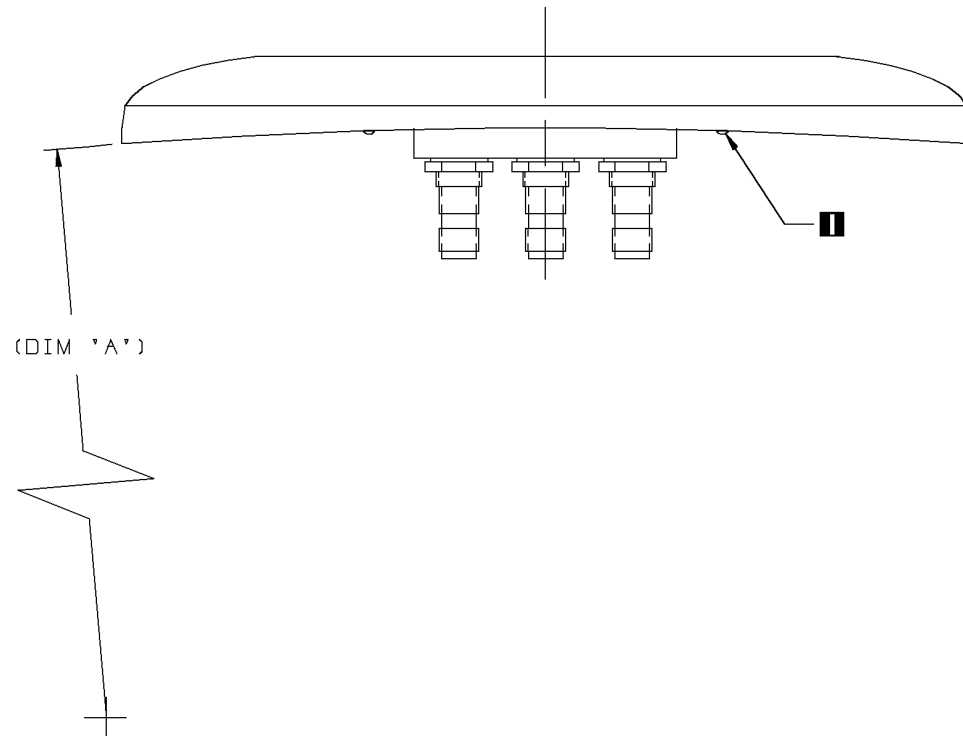

VIEW A-A  
(SEE TABLE 4)

ANTENNA PART NUMBERS  
FLAT ANTENNA BASE  
TABLE 3

NUMBER OF AIRCRAFT MOUNTING SCREWS	ANTENNA/ADAPTER ASSY PART NO. *	CONNECTOR EXTENSION (TABLE 2 DIM "B" REF)	MAXIMUM UNIT WEIGHT LB (KG)
4	7514081-901	1.560 MAX	2.80 (1.27)
4	7514081-913	.705 MAX	2.80 (1.27)
8	7514081-902	1.560 MAX	2.80 (1.27)
8	7514081-910	.705 MAX	2.80 (1.27)

ANTENNA PART NUMBERS  
CURVED ANTENNA BASE  
TABLE 4

NUMBER OF AIRCRAFT MOUNTING SCREWS	DIM "A" (REF)	ANTENNA/ADAPTER ASSY PART NO. *	CONNECTOR EXTENSION (TABLE 2 DIM "B" REF)	MAXIMUM UNIT WEIGHT LB (KG)
8	R 61.52 MAX	7514081-903	1.560 MAX	2.90 (1.32)
8	R 66.52 MAX	7514081-904	1.560 MAX	2.90 (1.32)
8	R 74.02 MAX	7514081-905	1.560 MAX	2.90 (1.32)
8	R 77.78 MAX	7514081-906	1.560 MAX	2.90 (1.32)
8	R 99.02 MAX	7514081-907	1.560 MAX	2.80 (1.27)
4	R 111.02 MAX	7514081-908	1.560 MAX	2.80 (1.27)
8	R 118.52 MAX	7514081-909	1.560 MAX	2.80 (1.27)
8	R 77.78 MAX	7514081-911	1.560 MAX	2.90 (1.32)
8	R 111.02 MAX	7514081-912	1.560 MAX	2.80 (1.27)
8	R 53.02 MAX	7514081-914	.705 MAX	3.00 (1.36)
8	R 44.80 MAX	7514081-915	.705 MAX	3.10 (1.41)
8	R 42.0 MAX	7514081-916	.705 MAX	3.20 (1.45)
8	R 85.06 MAX	7514081-917	1.560 MAX	2.90 (1.32)

\*THIS ASSEMBLY IS A COMPLETE ANTENNA ASSEMBLY READY FOR AIRCRAFT INSTALLATION.

E7514069-4-P  
AD-26792@

Figure 2-6 (Sheet 4). Directional Antenna Outline and Installation Diagram





**SYSTEM DESCRIPTION AND INSTALLATION MANUAL**  
 TCAS 3000 Traffic Alert and Collision Avoidance System

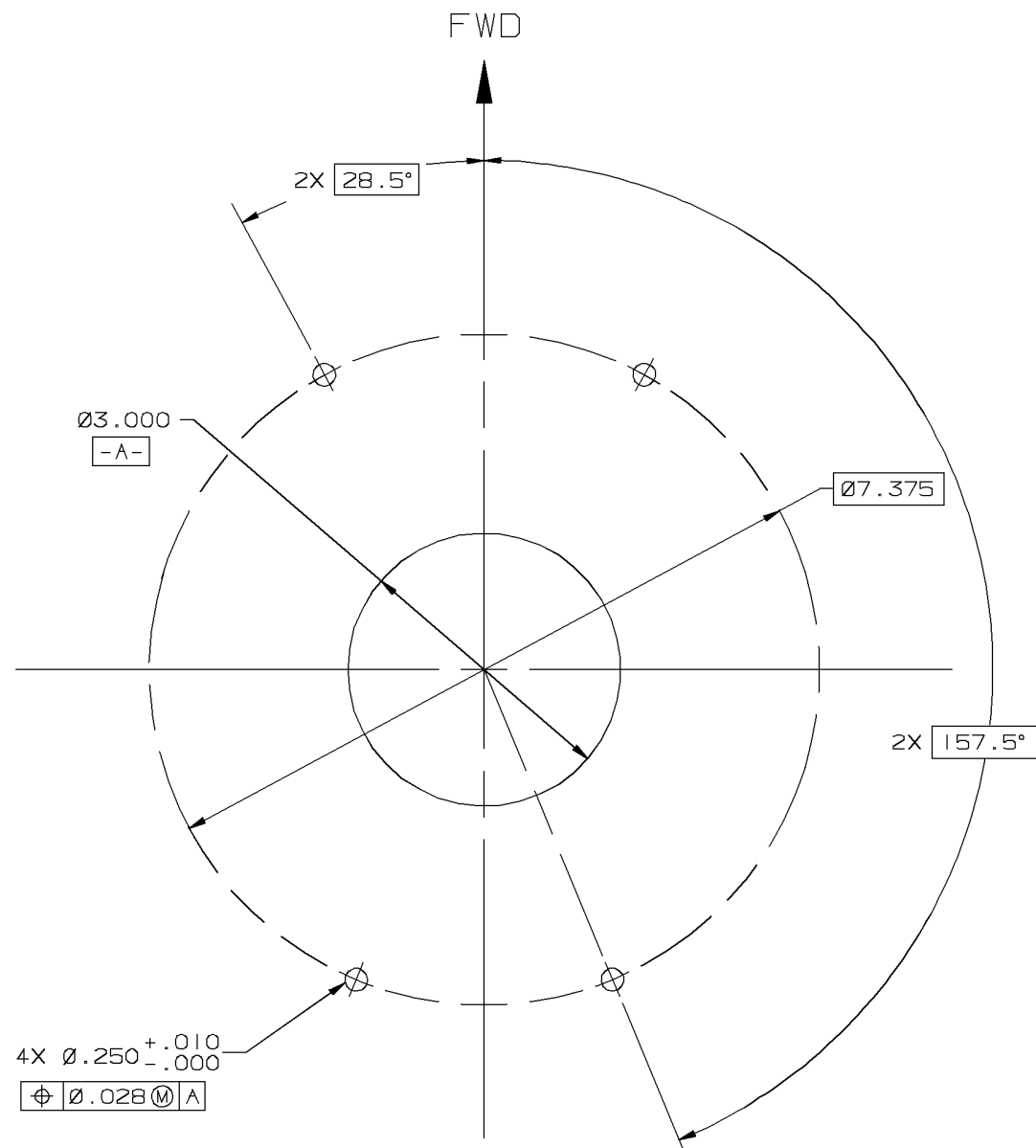

RECOMMENDED MOUNTING PATTERN

THIS CONFIGURATION IS FOR 7514081-901, 908 AND 913

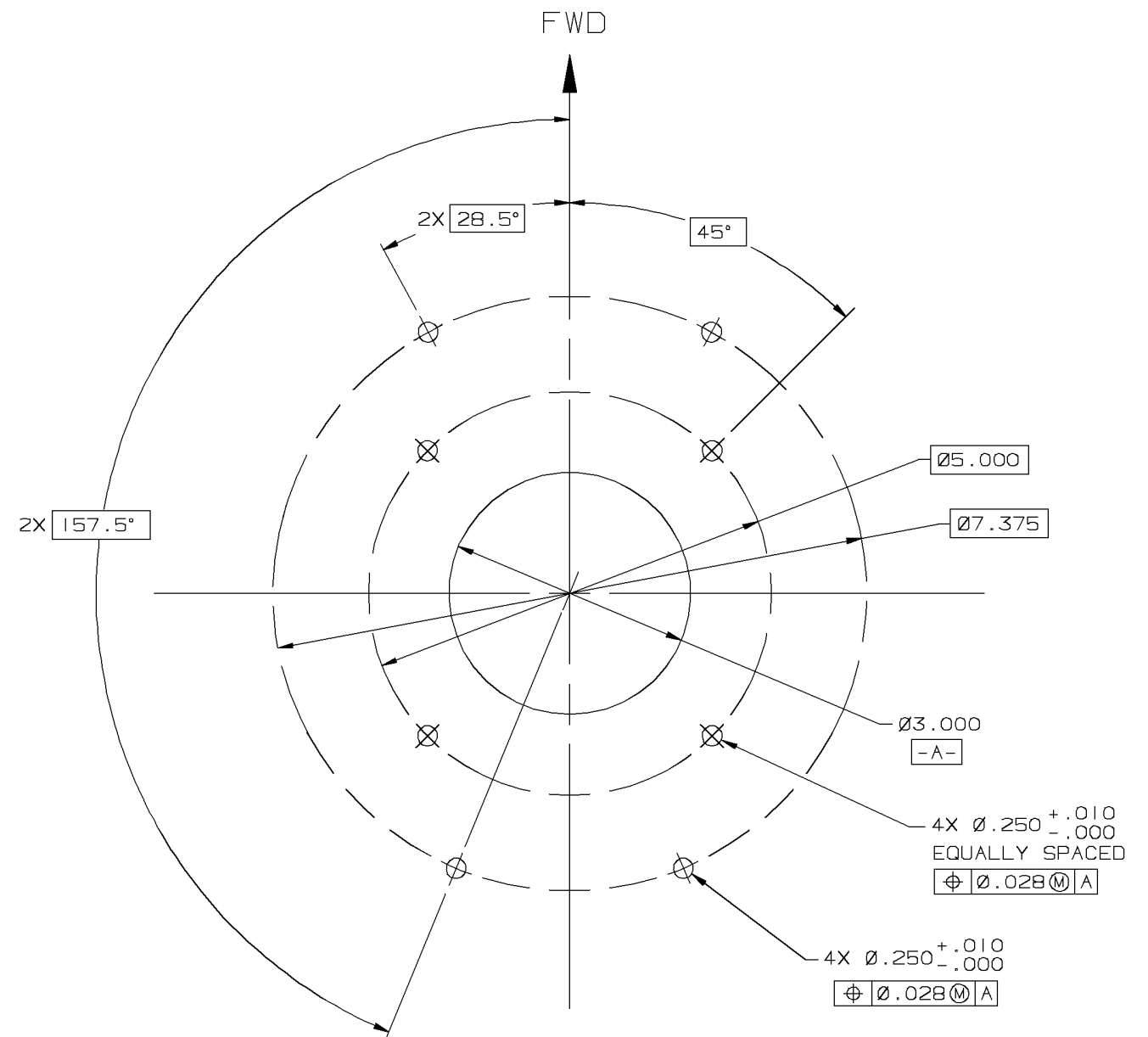

RECOMMENDED MOUNTING PATTERN

THIS CONFIGURATION IS FOR 7514081-902 THRU -907, -909 THRU -912, -914, -915, -916 AND -917

E7514069-5-P  
 AD-26793@

**Figure 2-6 (Sheet 5). Directional Antenna Outline and Installation Diagram**



**SYSTEM DESCRIPTION AND INSTALLATION MANUAL**  
TCAS 3000 Traffic Alert and Collision Avoidance System

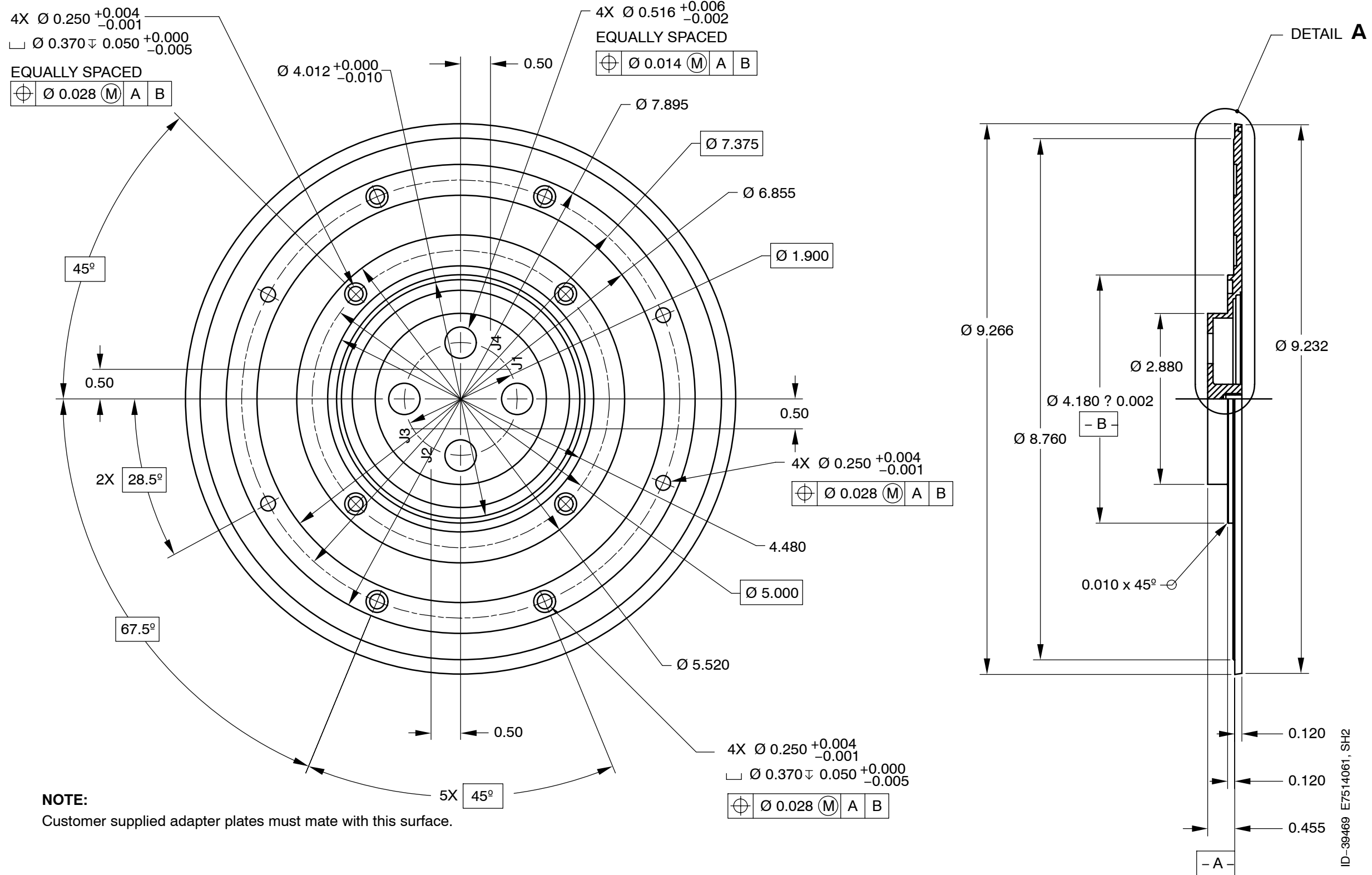
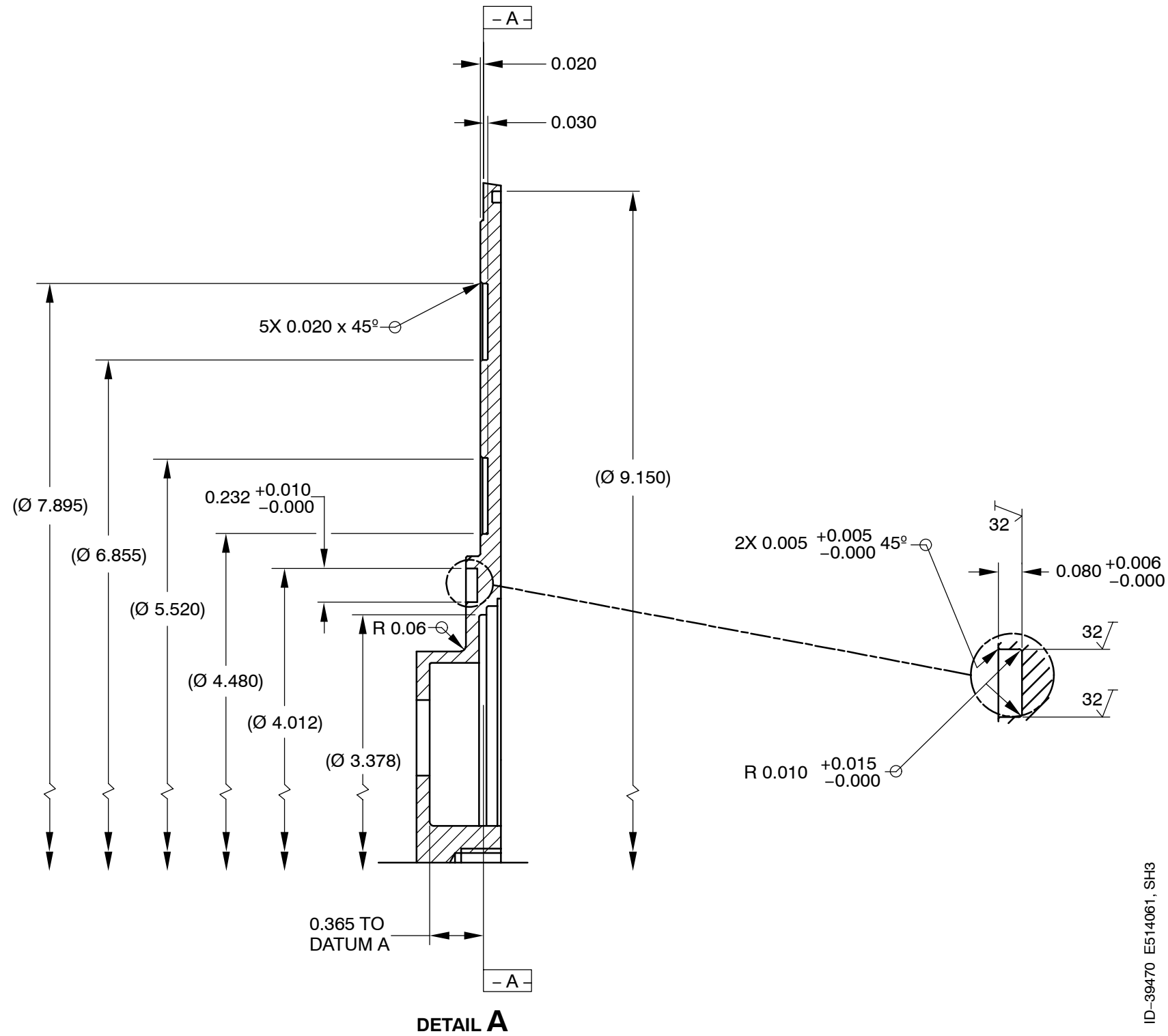

Figure 2-7 (Sheet 1). Directional Antenna Baseplate Outline and Installation Diagram



**SYSTEM DESCRIPTION AND INSTALLATION MANUAL**  
TCAS 3000 Traffic Alert and Collision Avoidance System



ID-39470 E514061, SH3

Figure 2-7 (Sheet 2). Directional Antenna Baseplate Outline and Installation Diagram

**34-43-23**

Page 2-33/(2-34 blank)  
15 Dec 2005



**SYSTEM DESCRIPTION AND INSTALLATION MANUAL**  
TCAS 3000 Traffic Alert and Collision Avoidance System

METRIC CONVERSION TABLE	
INCHES	MILLIMETERS
0.010	0.254
0.015	0.380
0.020	0.510
0.030	0.760
0.062	1.575
0.152	3.861
0.192	4.877
0.250	6.350
0.375	9.530
0.532	13.510
0.562	14.280
1.040	26.416
1.110	28.190
1.125	28.575
1.240	31.496
1.470	37.340
2.090	53.090
2.125	53.980
2.190	55.626
2.250	57.150
2.500	63.500
2.510	63.750
5.000	127.000
5.060	128.524
5.365	136.721
5.750	146.050

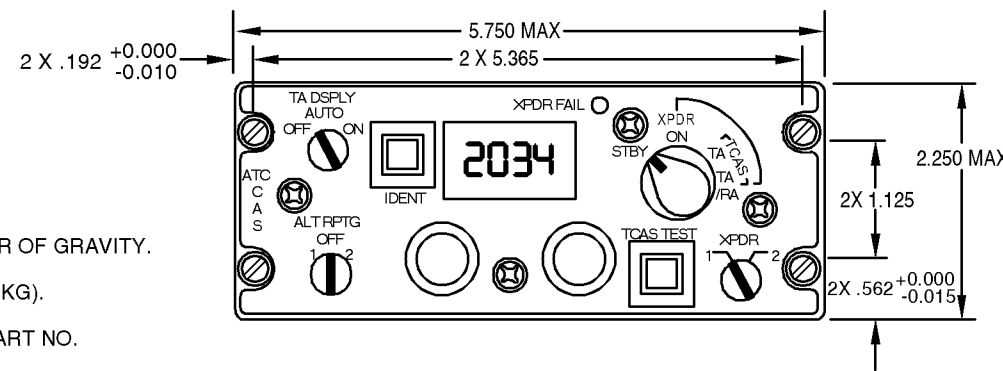
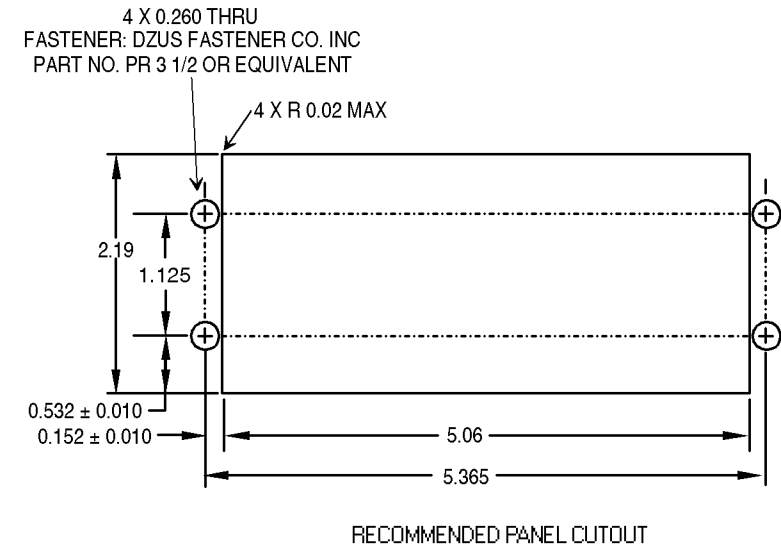
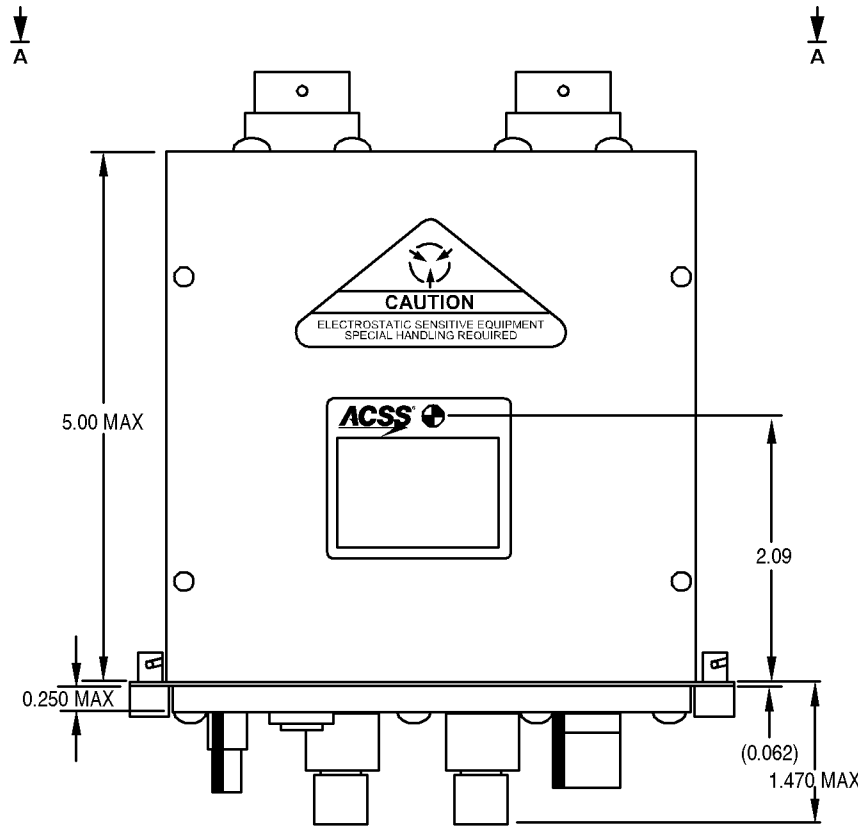

- NOTES: 1. ⊕ DENOTES APPROXIMATE CENTER OF GRAVITY.  
2. MAXIMUM UNIT WEIGHT 2.1 LB (0.95 KG).  
3. THIS DRAWING APPLIES TO ACSS PART NO. 4052190-902,-904,-906,-908.  
4. DIMENSIONS ARE IN INCHES. SEE METRIC CONVERSION TABLE FOR CORRESPONDING DIMENSIONS IN MILLIMETERS.

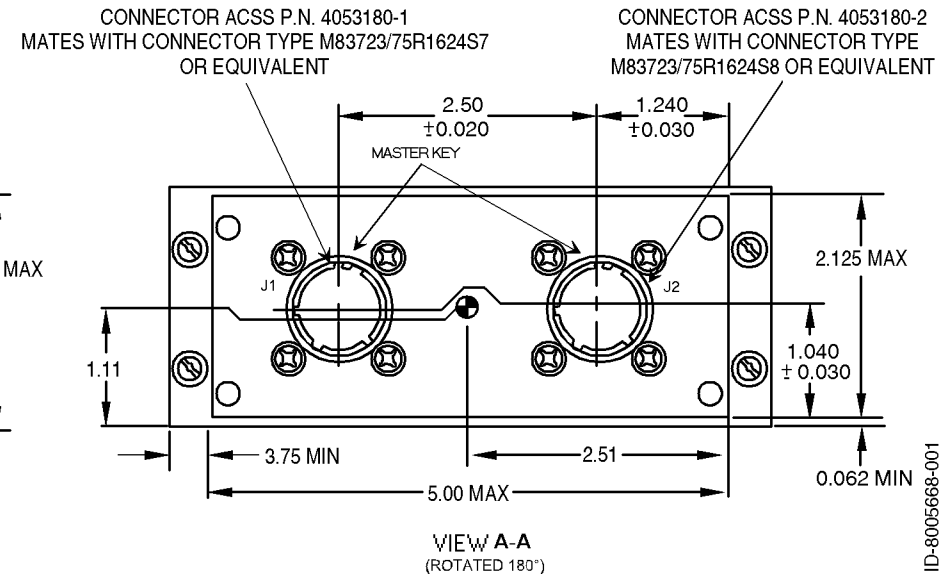
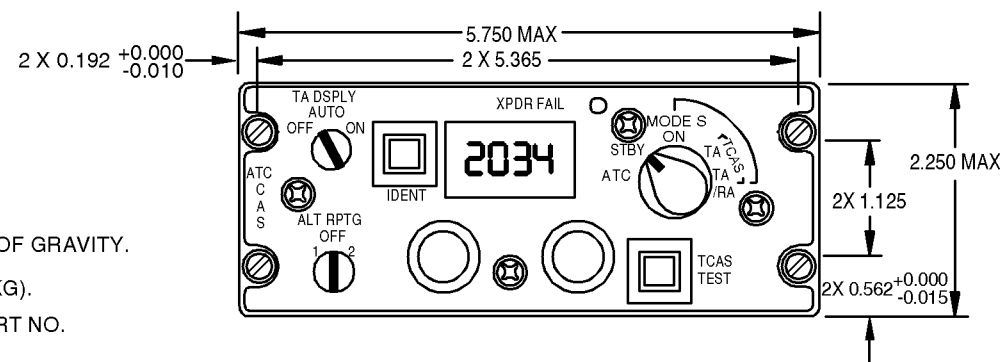
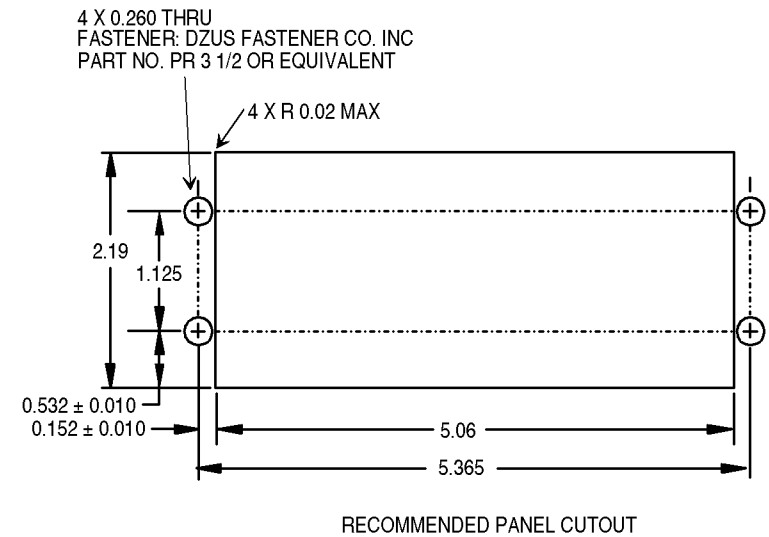
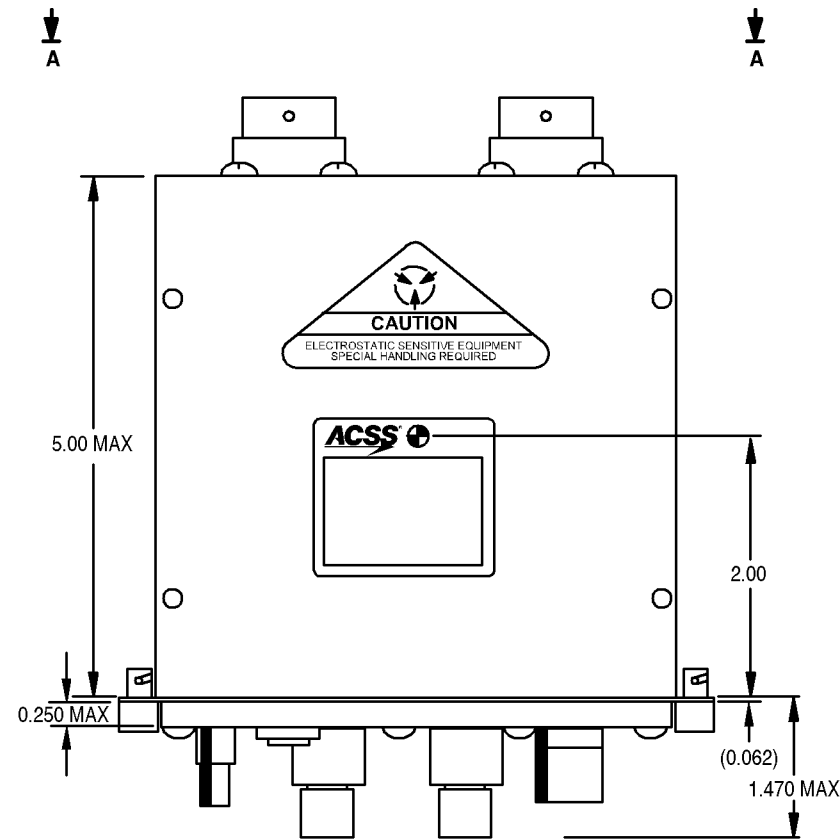

**Figure 2-8. Control Panel (Dual Mode S) Outline and Installation Diagram**



**SYSTEM DESCRIPTION AND INSTALLATION MANUAL**  
 TCAS 3000 Traffic Alert and Collision Avoidance System

METRIC CONVERSION TABLE	
INCHES	MILLIMETERS
0.010	0.254
0.015	0.380
0.020	0.510
0.062	1.575
0.152	3.861
0.192	4.877
0.250	6.350
0.375	9.530
0.532	13.510
0.562	14.280
1.062	26.975
1.110	28.190
1.125	28.575
1.250	31.750
1.470	37.340
2.000	50.800
2.125	53.980
2.190	55.626
2.250	57.150
2.470	62.740
2.500	63.500
5.000	127.000
5.060	128.524
5.365	163.271
5.750	146.050



- NOTES: 1. ● DENOTES APPROXIMATE CENTER OF GRAVITY.  
 2. MAXIMUM UNIT WEIGHT 1.9 LB (0.86 KG).  
 3. THIS DRAWING APPLIES TO ACSS PART NO. 4052190-903,-905,-907,-909.  
 4. DIMENSIONS ARE IN INCHES. SEE METRIC CONVERSION TABLE FOR CORRESPONDING DIMENSIONS IN MILLIMETERS.

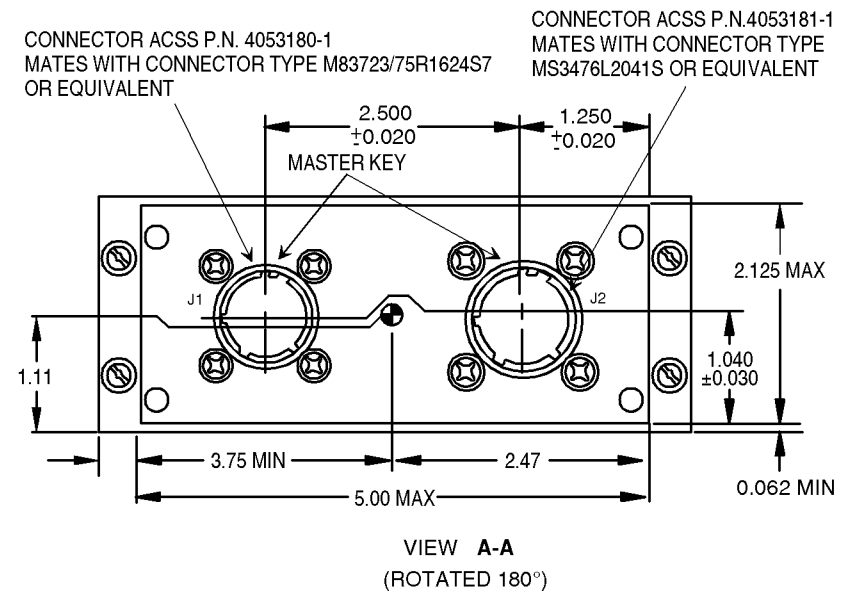

ID-8005669-001

**Figure 2-9. Control Panel (ATCRBS-Mode S) Outline and Installation Diagram**



**SYSTEM DESCRIPTION AND INSTALLATION MANUAL**  
TCAS 3000 Traffic Alert and Collision Avoidance System

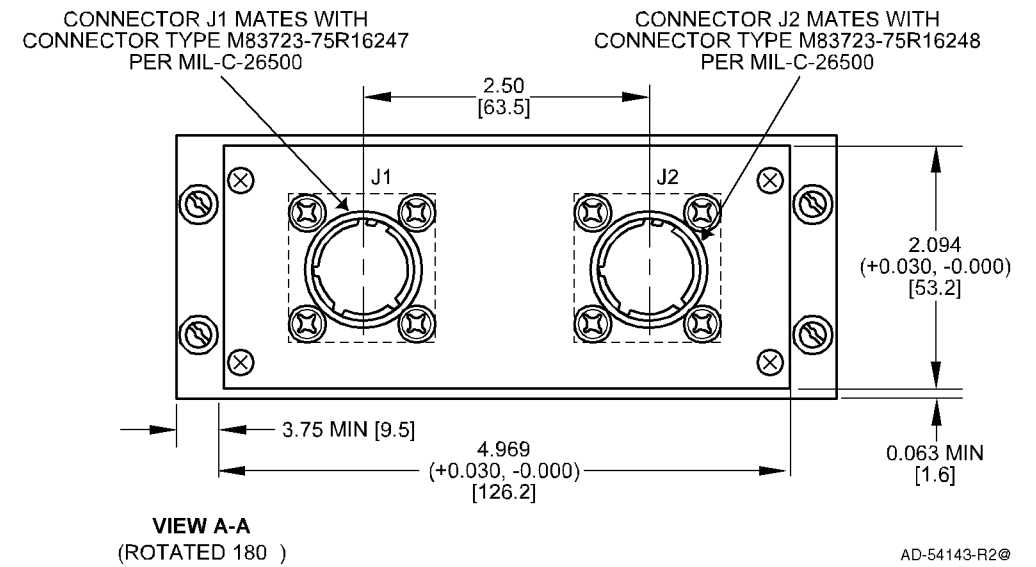
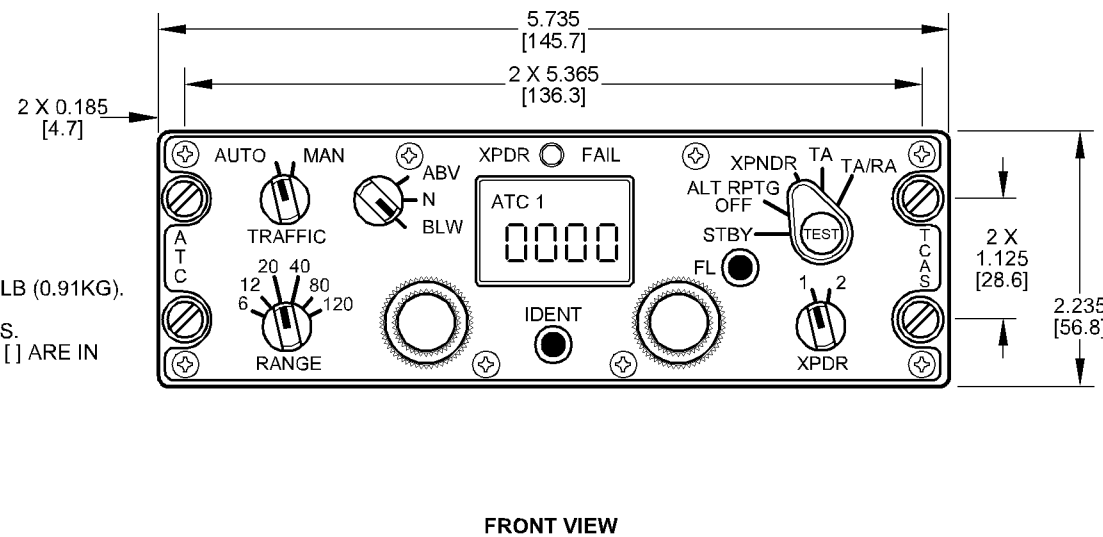
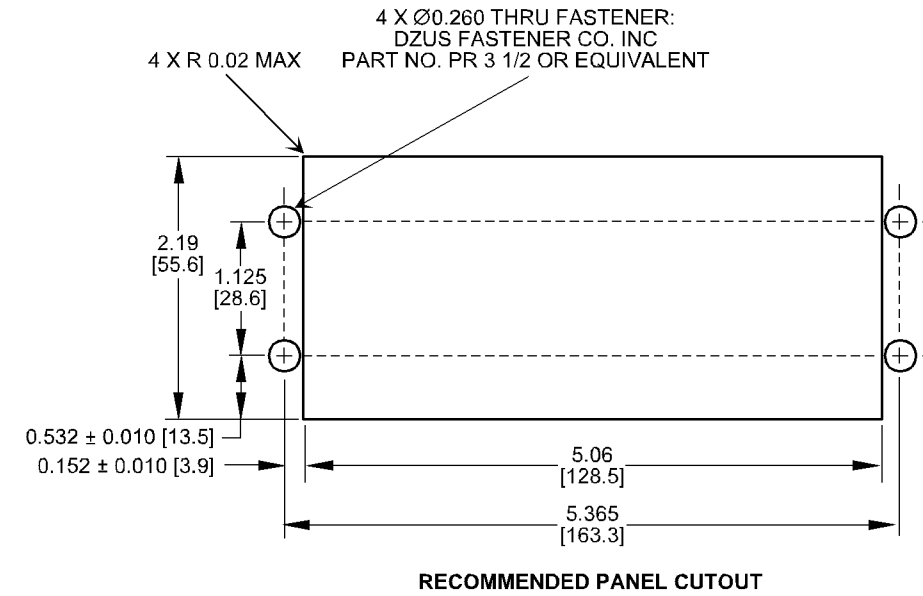
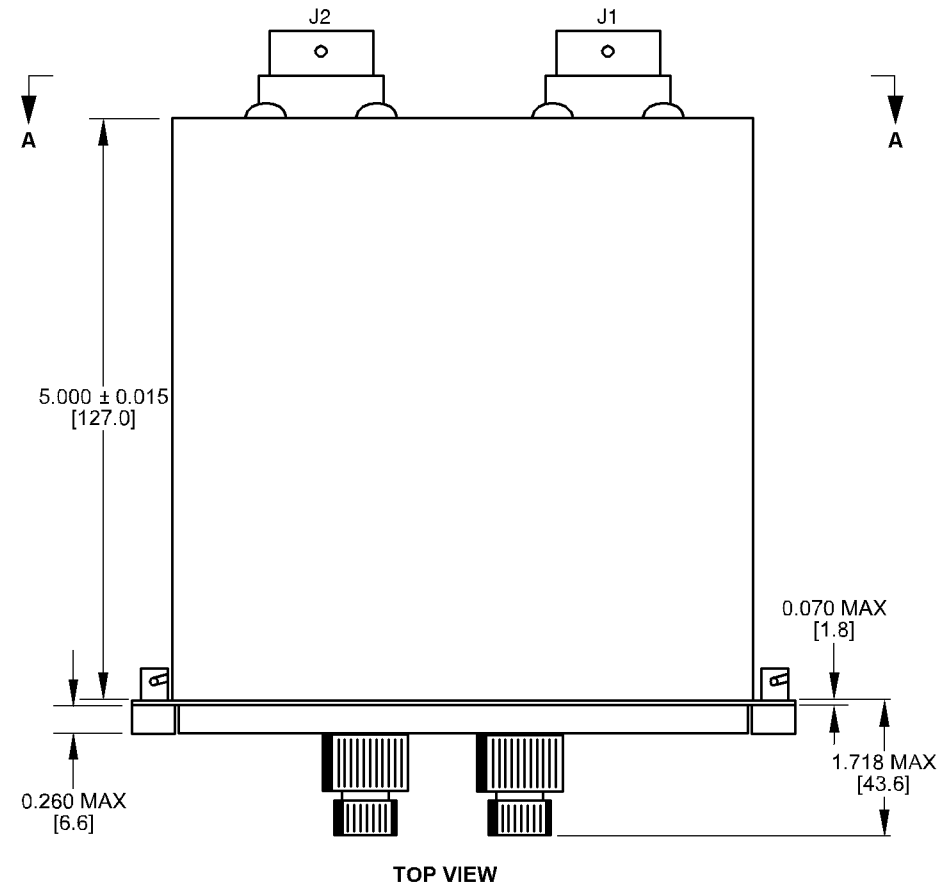

- NOTES:
1. MAXIMUM UNIT WEIGHT 2.0LB (0.91KG).
  2. DIMENSIONS ARE IN INCHES. DIMENSIONS IN BRACKETS [ ] ARE IN MILLIMETERS.

**Figure 2-10.**  
**Gables G7130-XX Control Panel Outline and Installation Diagram**



**SYSTEM DESCRIPTION AND INSTALLATION MANUAL**  
 TCAS 3000 Traffic Alert and Collision Avoidance System

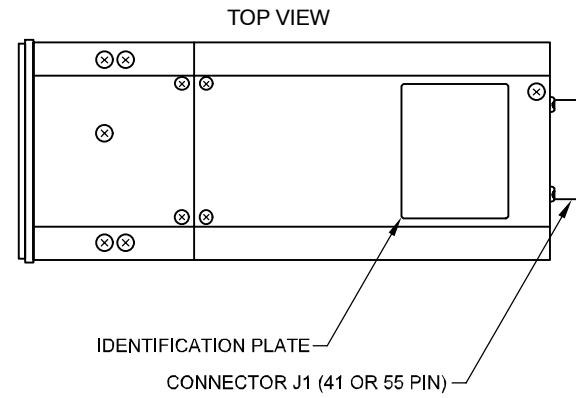
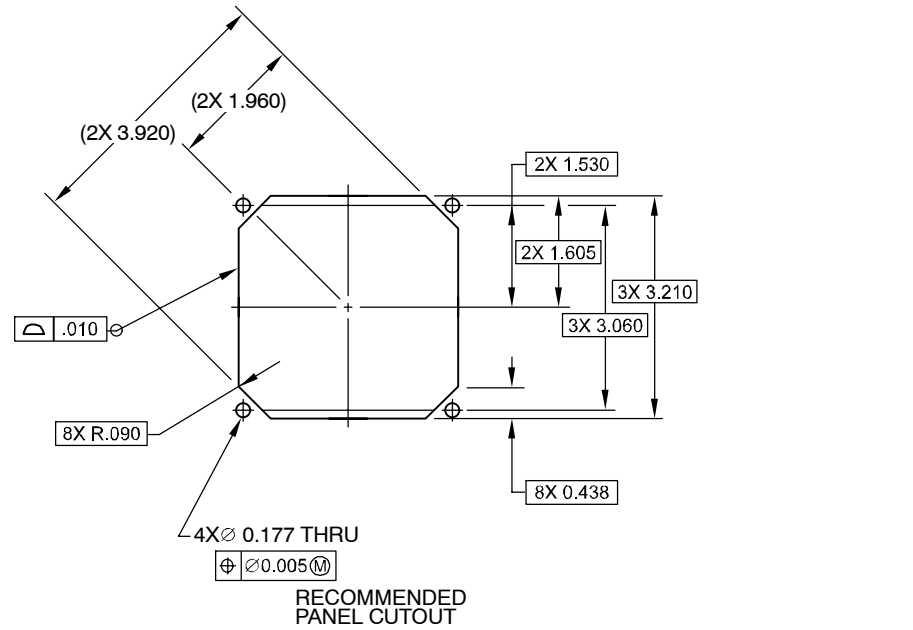

CONVERSION TABLE			
INCHES	MILLIMETERS	INCHES	MILLIMETERS
0.005	0.13	1.530	38.86
0.010	0.25	1.590	40.39
0.015	0.38	1.605	40.77
0.0425	1.08	1.960	49.78
0.090	2.29	3.060	77.72
0.100	2.54	3.175	80.65
0.125	3.18	3.210	81.53
0.135	3.43	3.260	82.80
0.177	4.50	3.885	98.68
0.225	5.72	3.900	99.06
0.428	10.87	3.920	99.57
0.438	11.13	3.970	100.84
0.453	11.51	8.190	208.03

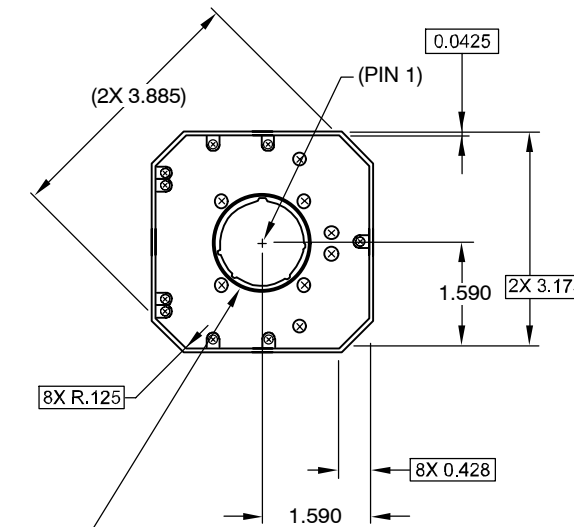
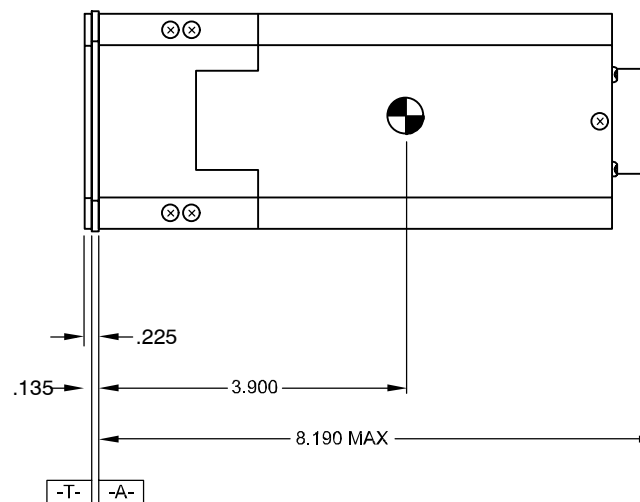
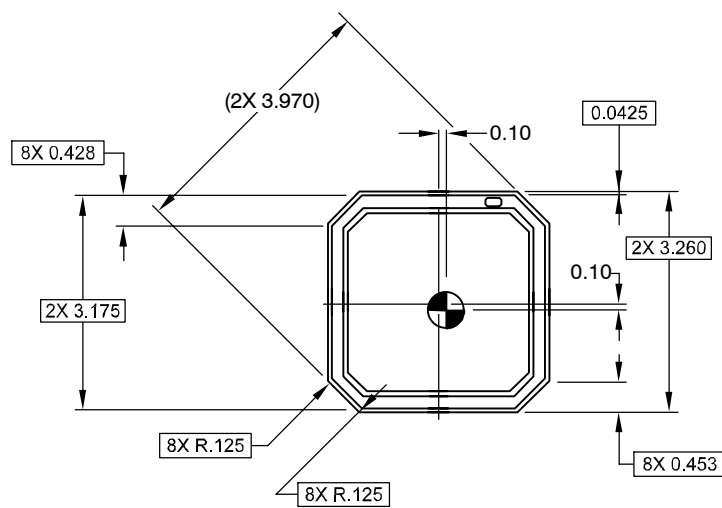

CONNECTOR J1 (41 PIN) MATES WITH M83723/75R2041N OR EQUIVALENT  
 41-PIN CONNECTOR BACKSHELL IS M85049/52-1-20N OR EQUIVALENT  
 CONNECTOR J1 (55 PIN) MATES WITH M83723/75R2255N OR EQUIVALENT  
 55-PIN CONNECTOR BACKSHELL IS M85049/52-1-22N OR EQUIVALENT

- NOTES:
1. MAXIMUM WEIGHT 4.0 LBS (1.81 KG).
  2. DIMENSIONS SHOWN ARE IN INCHES. REFER TO METRIC CONVERSION TABLE FOR CORRESPONDING DIMENSIONS IN MILLIMETERS.
  3. DENOTES APPROXIMATE CENTER OF GRAVITY.

AD-31673-R1@

Figure 2-11. VSI/TRA Outline and Installation Diagram



**SYSTEM DESCRIPTION AND INSTALLATION MANUAL**  
 TCAS 3000 Traffic Alert and Collision Avoidance System

CONVERSION TABLE	
INCHES	MILLIMETERS
0.625	15.88
0.70	17.78
0.825	20.96
0.87	22.10
0.975	24.77
0.985	25.02
1.46	37.08
1.50	38.10
1.57	39.88
2.25	57.15
2.80	71.12
4.02	102.11
7.40	187.96

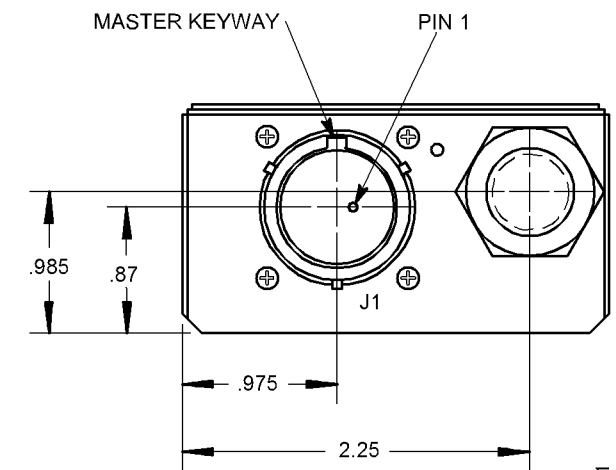
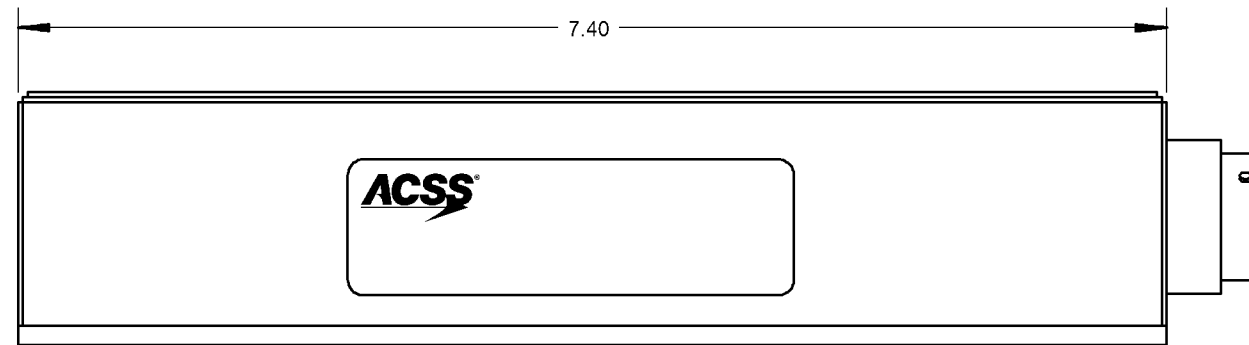
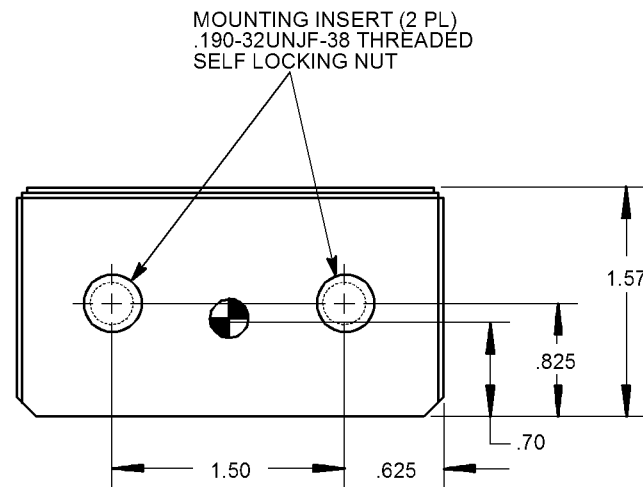
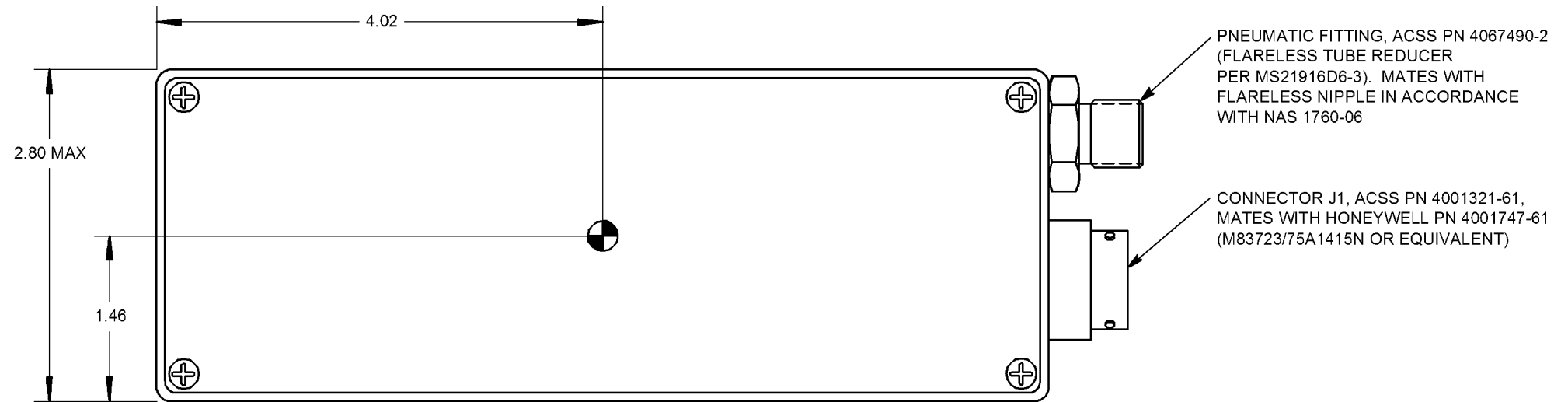

- NOTES: 1. MAXIMUM WEIGHT 2.0 LBS (0.907 KG).  
 2. DIMENSIONS SHOWN ARE IN INCHES. REFER TO METRIC CONVERSION TABLE FOR CORRESPONDING DIMENSIONS IN MILLIMETERS.  
 3. DENOTES APPROXIMATE CENTER OF GRAVITY.

ID-8005670-101

Figure 2-12 (Sheet 1). Pressure Transducer Module Outline and Installation Diagram





**SYSTEM DESCRIPTION AND INSTALLATION MANUAL**  
TCAS 3000 Traffic Alert and Collision Avoidance System

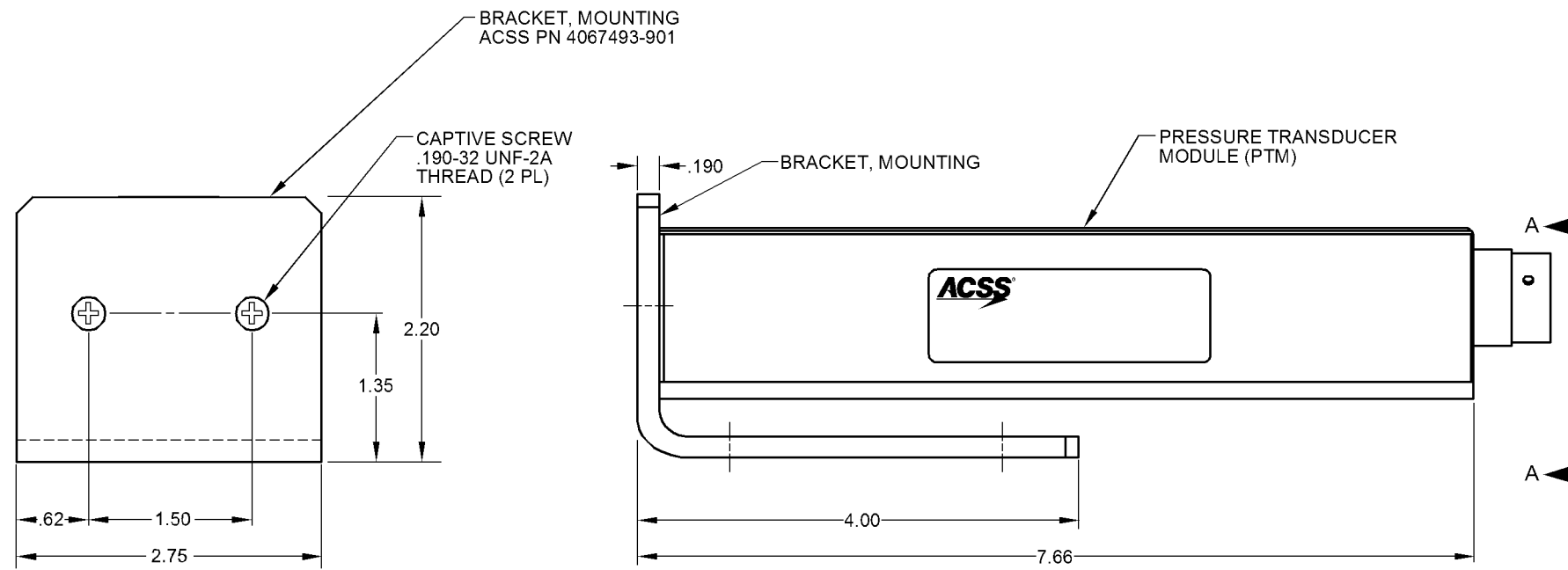

CONVERSION TABLE	
INCHES	MILLIMETERS
0.001	0.025
0.004	0.102
0.190	4.83
0.219	5.56
0.38	9.65
0.62	15.75
0.75	19.05
1.35	34.29
1.50	38.10
2.00	50.80
2.20	55.88
2.50	63.50
2.75	69.85
4.00	101.60
7.66	194.56

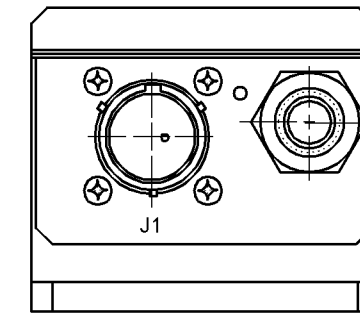
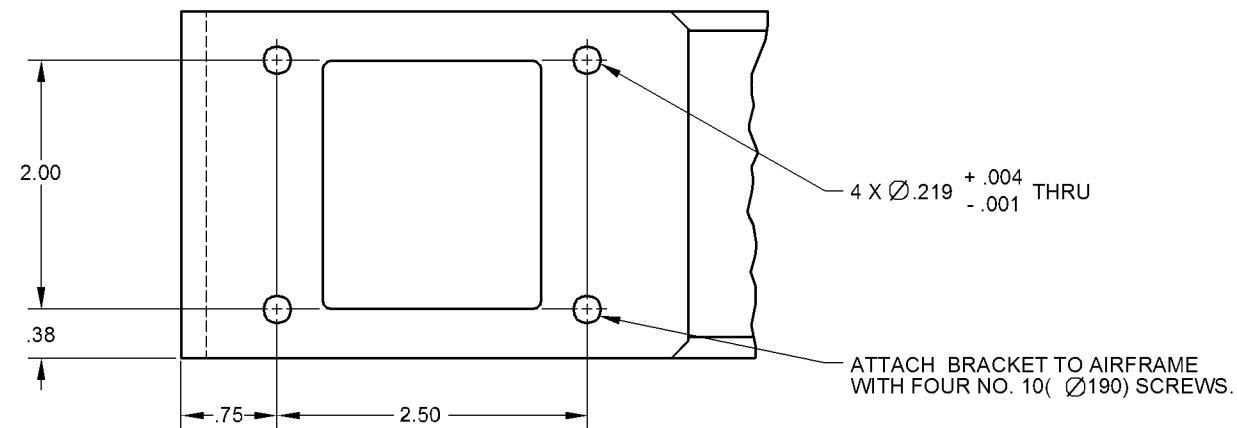

VIEW A-A

PTM ON A RIGHT-ANGLE MOUNTING BRACKET

ID-8005671-001

Figure 2-12 (Sheet 2). Pressure Transducer Module Outline and Installation Diagram



**SYSTEM DESCRIPTION AND INSTALLATION MANUAL**  
TCAS 3000 Traffic Alert and Collision Avoidance System

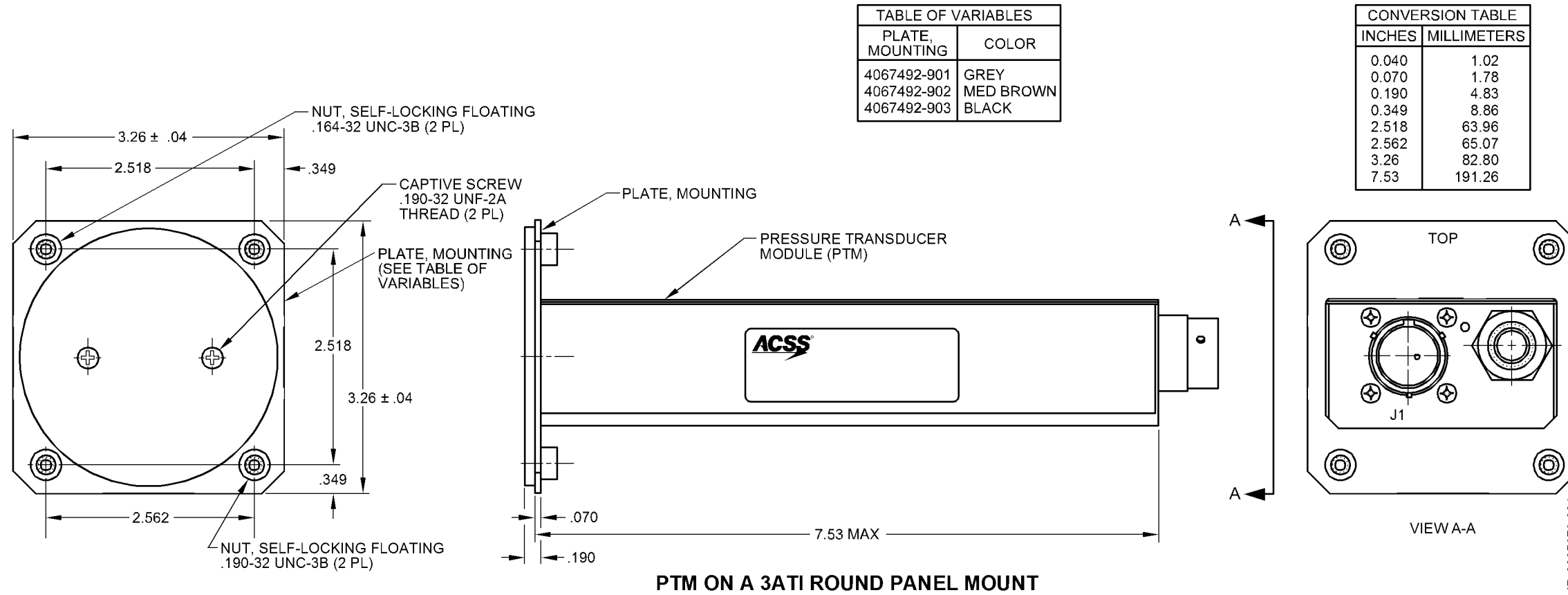

Figure 2-12 (Sheet 3). Pressure Transducer Module Outline and Installation Diagram



**SYSTEM DESCRIPTION AND INSTALLATION MANUAL**  
TCAS 3000 Traffic Alert and Collision Avoidance System

SOFTWARE/LRU LABEL CONTENTS (FOR 115 VOLT UNITS SUPPLIED TO BOEING ONLY)	
PART NUMBER	7517800-10001, 7517800-10002, 7517800-10004, 7517800-10005
DO-178B LEVEL	B

HARDWARE LABEL CONTENTS (FOR 115 VOLT UNITS SUPPLIED TO BOEING ONLY)	
MODEL NUMBER	XS-950
UNIT NAME	DATA LINK TRANSPONDER
HARDWARE PART NUMBER	7517800-10
WEIGHT	11.5
ENVIRONMENTAL CATEGORY	DO-160C ENV CAT [A2E1]-BB[CLMY]XXXXXXXXZEAERZA3E3XX
TSO	C112 CL043, I21, F11
FCC ID	FCC ID 888XS-950

APPROXIMATE CENTER OF GRAVITY DIMENSIONS			
UNIT PART NUMBER	DIM X ±.25	DIM Y ±.25	DIM Z ±.25
7517800-10XXX THRU 7517800-54XXX (115 VOLT UNITS)	2.59	3.63	5.49
7517800-55XXX THRU 7517800-99XXX (28 VOLT UNITS)	2.43	3.78	5.57

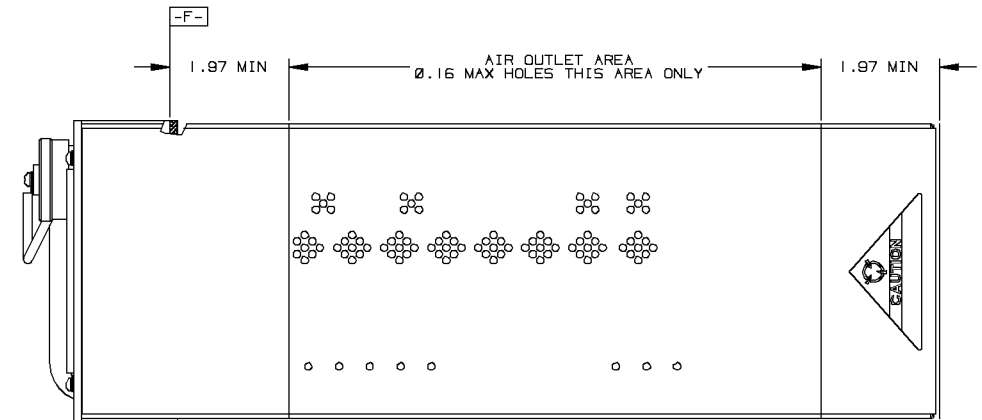

NOTES:

- UNIT WEIGHT:  
UNIT PART NUMBER 7517800-10XXX THRU 7517800-54XXX (115 VOLT UNITS) 11.5±.35 POUNDS (5.22±.16 KILOGRAMS).  
UNIT PART NUMBER 7517800-55XXX THRU 7517800-99XXX (28 VOLT UNITS) 10.3±.31 POUNDS (4.67±.14 KILOGRAMS).
- DENOTES APPROXIMATE CENTER OF GRAVITY.
- DARKENED PORTION INDICATES SOLID PART OF POLARIZING KEYWAY.
- THE INSTALLATION IS IN ACCORDANCE WITH ARINC 600 NUMBER 4 LRU.
- DIMENSIONS ARE IN INCHES. SEE METRIC CONVERSION TABLE FOR CORRESPONDING DIMENSIONS IN MILLIMETERS.
- THE UNIT MAY ACCEPT EITHER BLOW-THRU COOLING PER ARINC 600 OR DRAW-THRU COOLING PER ARINC 404. FOR TRANSPONDER OPERATION WITHOUT EXTENDED DOWNLINK (DELM) DATA LINK, THE NORMAL OPERATION COOLING AIRFLOW REQUIREMENT PER ARINC 600 IS 28.7±2 POUNDS PER HOUR (13±0.9 KILOGRAMS/HOUR). FOR TRANSPONDER OPERATION WITH EXTENDED DOWNLINK (DELM) DATA LINK, THE NORMAL OPERATION COOLING AIRFLOW REQUIREMENT PER ARINC 600 IS 40.7±2 POUNDS PER HOUR (18.4±0.9 KILOGRAMS/HOUR). AT ALL OF THE AIRFLOW RATES, THE PRESSURE DROP THROUGH THE TRANSPONDER IS .20±.12 INCHES OF WATER (5±3 MILLIMETERS OF WATER).
- THIS DRAWING DEFINES END UNIT 7517800-YYXXX.  
YY = HARDWARE DASH NUMBER FROM 10 THROUGH 99.  
XXX = SOFTWARE DASH NUMBER FROM 001 THROUGH 999.  
FOR UNITS SUPPLIED TO BOEING SEE HARDWARE AND SOFTWARE/LRU LABEL CONTENT TABLES.
- UNIT FINISH: BLACK SEMI-GLOSS WITH SEMI-GLOSS CLEAR SPLATTER ALL OVER EXCEPT FOR BOTTOM WHICH IS CHEMICAL FILM.
- NO OTHER PROJECTIONS EXCEPT CONNECTOR MOUNTING HARDWARE ARE PERMITTED IN AREA DEFINED AS ZONE A.
- THIS INFORMATION IS PROVIDED TO COMPLY WITH 14 CFR PART 21.605 AND SECTION (c) DATA REQUIREMENTS OF THE TSO'S APPLICABLE TO HONEYWELL PRODUCT, PART NUMBER 7517800-20012: THE ANALOG ALTITUDE INTERFACE FUNCTIONALITY PROVIDED BY THE PART NUMBERS 7517800-20012 HAS NOT BEEN EVALUATED AS PART OF ANY TSO MINIMUM OPERATIONAL PERFORMANCE STANDARDS. THE INSTALLER OF ANY OF THE ABOVE LISTED PRODUCTS, WISHING TO USE THE NON TSO APPLICABLE FUNCTIONALITY STATED ABOVE MUST ENSURE THAT THIS FUNCTIONALITY IS EVALUATED AS PART OF A TYPE CERTIFICATION, SUPPLEMENTAL TYPE CERTIFICATION, OR AMENDED TYPE CERTIFICATION PROGRAM FOR THE AIRCRAFT IN WHICH THIS FUNCTIONALITY IS TO BE UTILIZED.
- THIS INFORMATION IS PROVIDED TO COMPLY WITH 14 CFR PART 21.605 AND SECTION (c) DATA REQUIREMENTS OF THE TSO'S APPLICABLE TO HONEYWELL PRODUCT, PART NUMBER 7517800-10003: THE AIRBORNE DEPENDENCY SURVEILLANCE - BROADCAST (ADS-B) FUNCTIONALITY PROVIDED BY THE PART NUMBER 7517800-10003 HAS NOT BEEN EVALUATED AS PART OF ANY TSO MINIMUM OPERATIONAL PERFORMANCE STANDARDS. THE INSTALLER OF ANY OF THE ABOVE LISTED PRODUCTS, WISHING TO USE THE NON TSO APPLICABLE FUNCTIONALITY STATED ABOVE MUST ENSURE THAT THIS FUNCTIONALITY IS EVALUATED AS PART OF A TYPE CERTIFICATION, SUPPLEMENTAL TYPE CERTIFICATION, OR AMENDED TYPE CERTIFICATION PROGRAM FOR THE AIRCRAFT IN WHICH THIS FUNCTIONALITY IS TO BE UTILIZED.

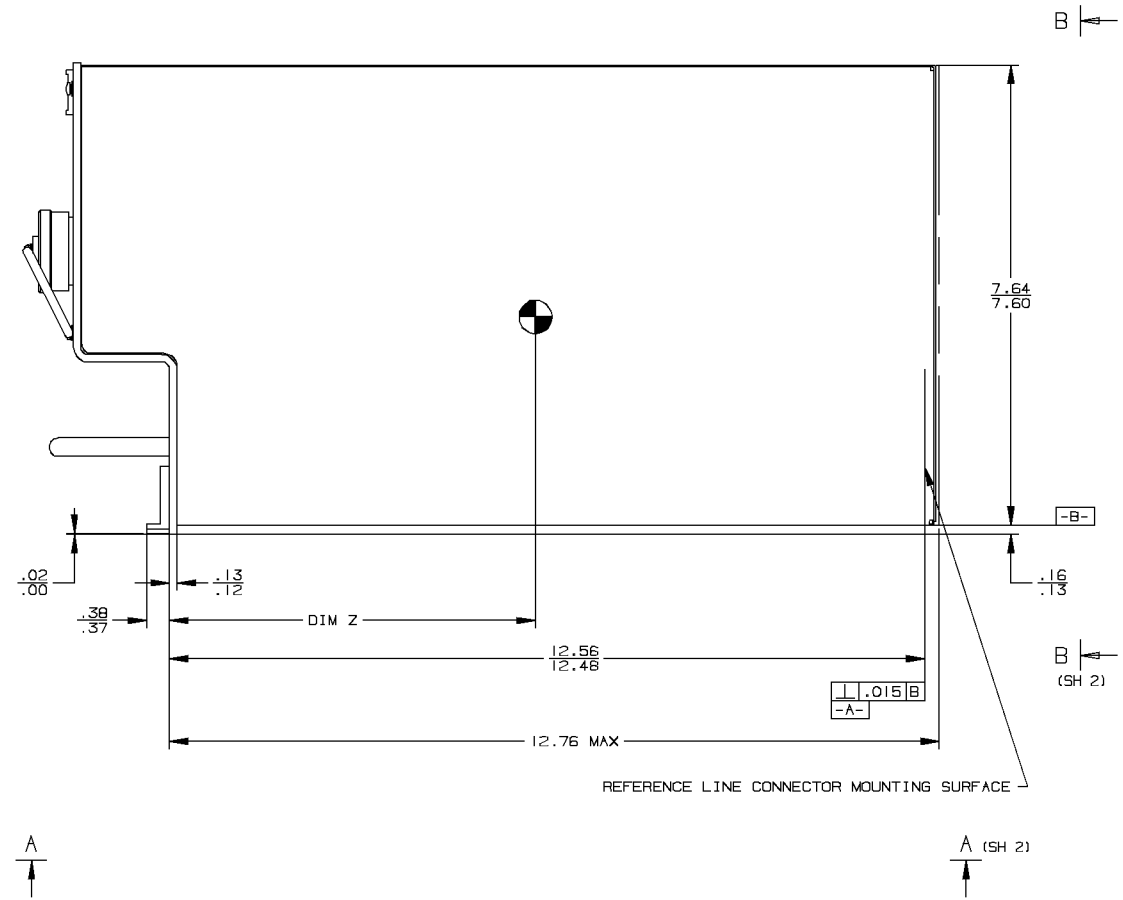
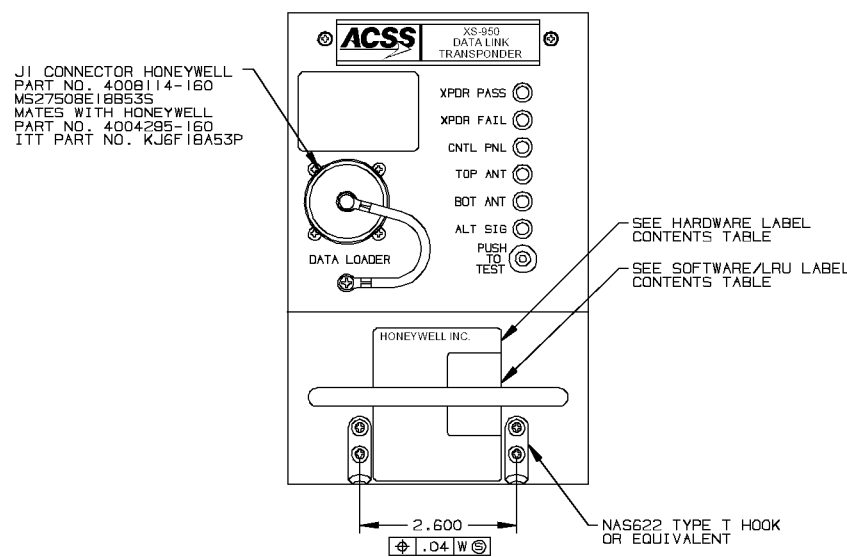

Figure 2-13 (Sheet 1). XS-950 Data Link Transponder Outline and Installation Diagram



**SYSTEM DESCRIPTION AND INSTALLATION MANUAL**  
 TCAS 3000 Traffic Alert and Collision Avoidance System

CONVERSION TABLE	
INCHES	MILLIMETERS
.010	.254
.015	.381
.020	.508
.025	.635
.040	1.016
.08	2.03
.12	3.05
.13	3.30
.16	4.06
.25	6.35
.37	9.40
.38	9.65
.81	20.57
1.00	25.40
1.97	50.04
2.43	61.722
2.50	63.50
2.59	65.79
2.600	66.040
3.63	92.20
3.78	96.01
4.50	114.30
4.86	123.44
4.90	124.46
5.49	139.45
5.57	141.48
6.89	175.01
7.60	193.04
7.64	194.06
11.30	287.02
12.48	316.89
12.56	319.02
12.76	324.10

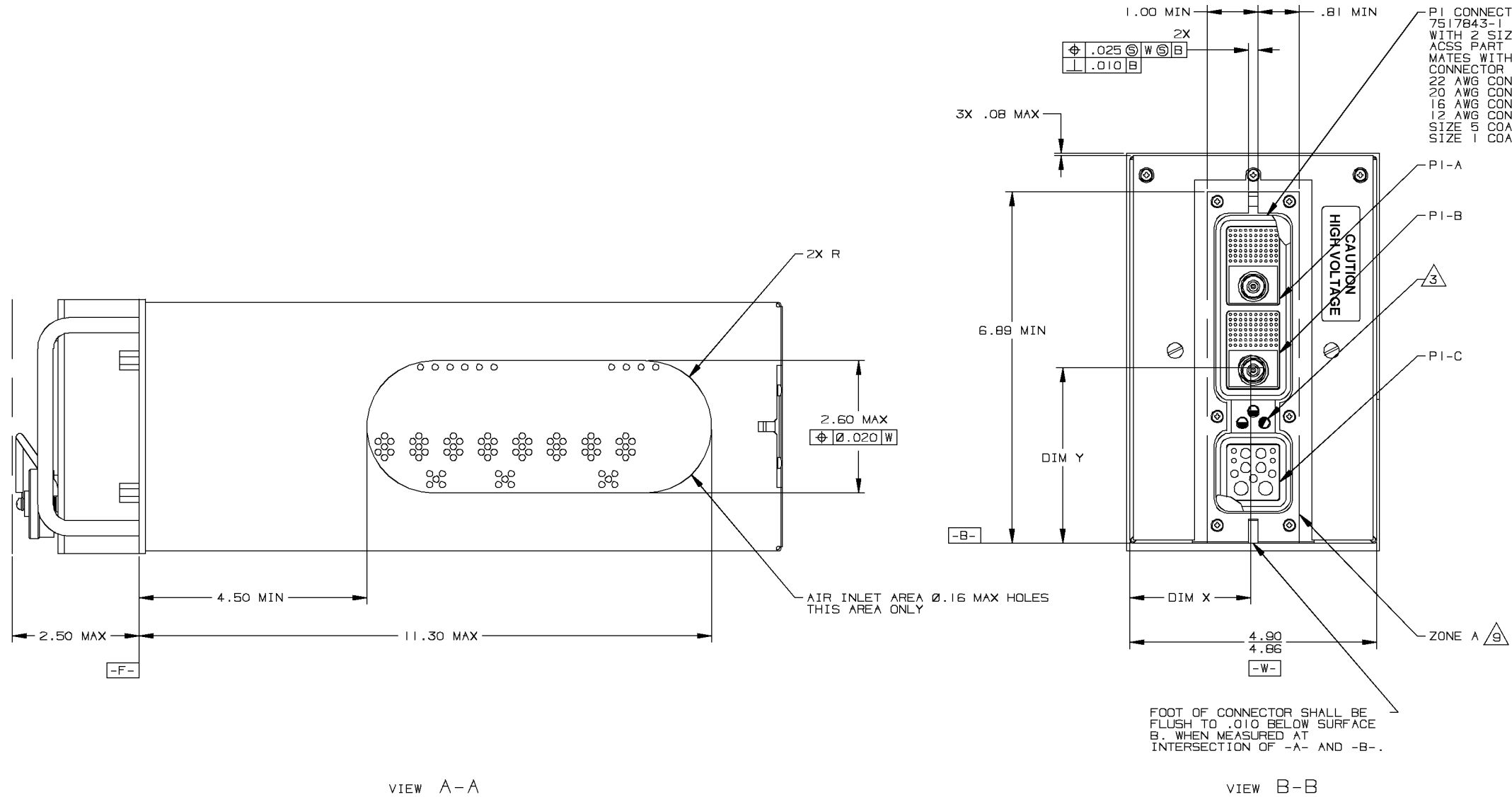

Figure 2-13 (Sheet 2). XS-950 Data Link Transponder Outline and Installation Diagram



**SYSTEM DESCRIPTION AND INSTALLATION MANUAL**  
TCAS 3000 Traffic Alert and Collision Avoidance System

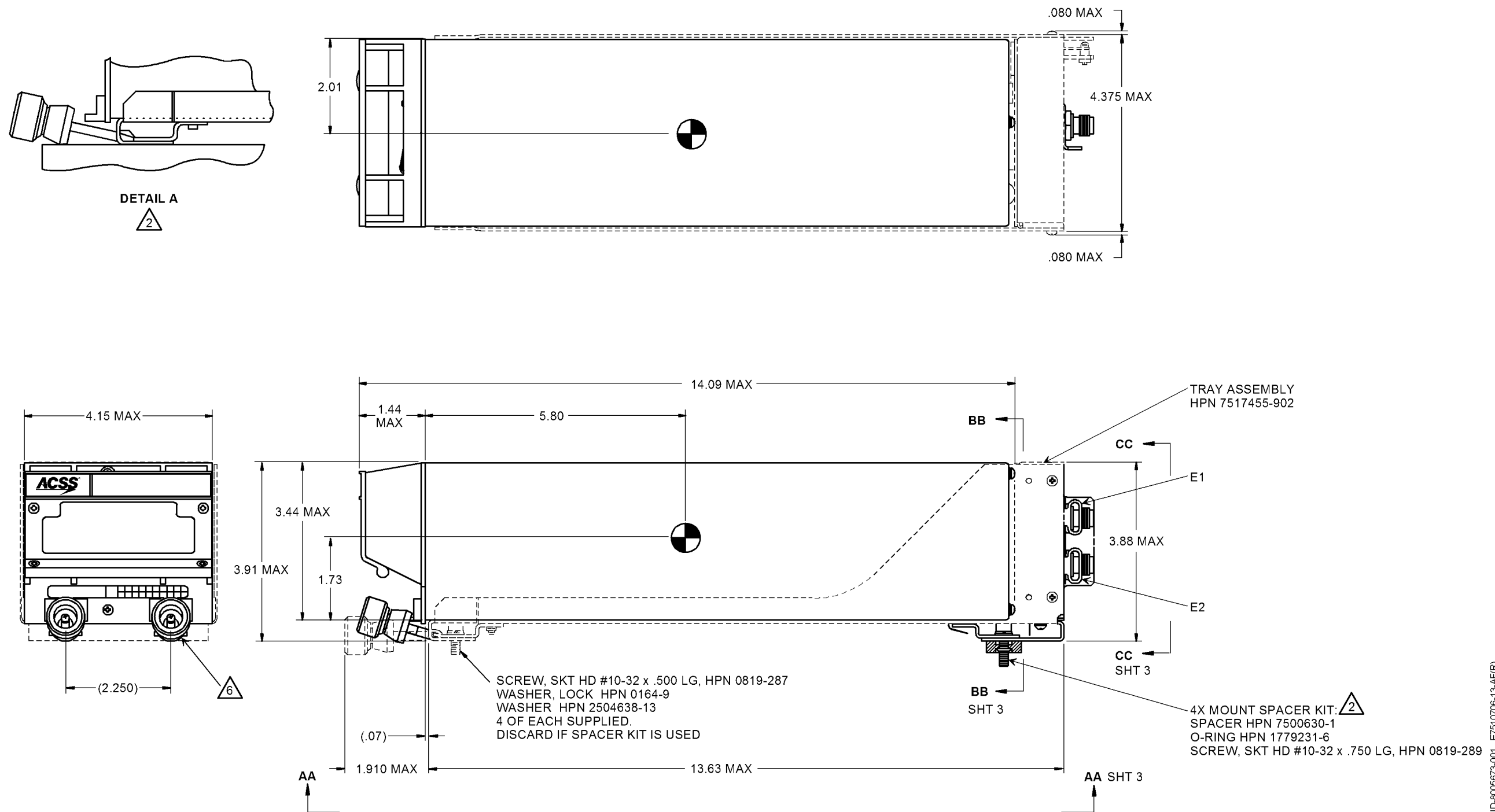

Figure 2-14 (Sheet 1). RCZ-852 Mode S Transponder Outline and Installation Diagram



**SYSTEM DESCRIPTION AND INSTALLATION MANUAL**  
 TCAS 3000 Traffic Alert and Collision Avoidance System

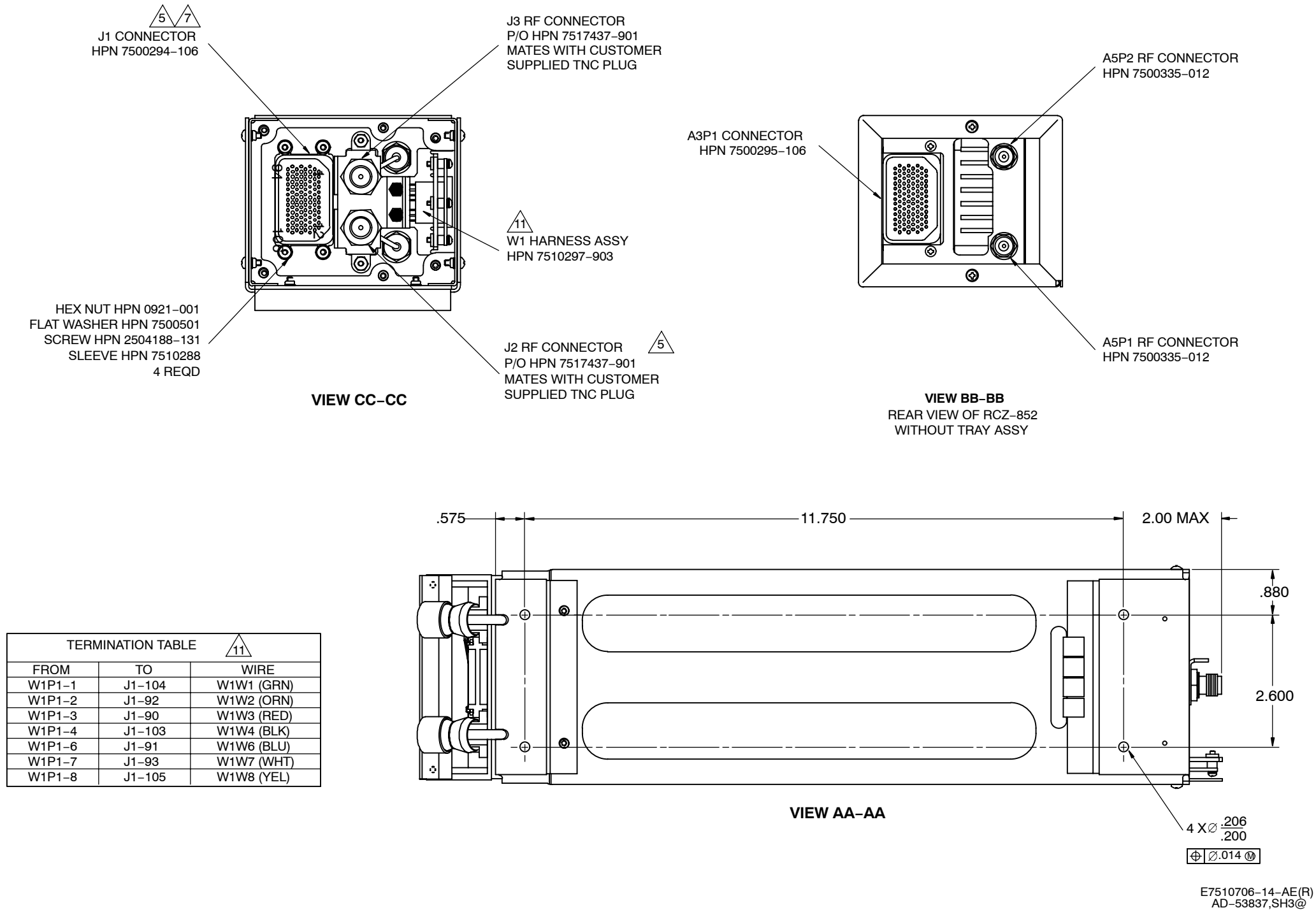

Figure 2-14 (Sheet 2). RCZ-852 Mode S Transponder Outline and Installation Diagram



**SYSTEM DESCRIPTION AND INSTALLATION MANUAL**  
TCAS 3000 Traffic Alert and Collision Avoidance System

## **ELECTRICAL INSTALLATION**

### **1. General**

This section gives electrical installation procedures, power distribution, and interconnect information for each component on the TCAS 3000 system.

### **2. Equipment and Materials**

For new TCAS 3000 installations, refer to Table 1-1 for RCZ-852 Transponder Installation Kit information. For all other components, refer to the applicable Outline and Installation Diagram in the MECHANICAL INSTALLATION section for mating connector part numbers.

### **3. Electrical Installation Procedure**

The information necessary to provide the electrical interconnections is contained in the following paragraphs. Refer to Section 4, LOADING/GRADIENT SPECIFICATIONS, for a list of the signal names used in the interconnect diagrams and tables.

### **4. Electrical Installation**

#### **A. TCAS 3000 Computer Units**

Figure 3-1 shows some general types of TCAS system installations, using various combinations of controllers (control panels) and transponders.

The electrical installation of the TCAS Computer Units is detailed in Figure 3-2. The various installation options require different electrical connections as described on the interconnect diagram and the paragraphs that follow.

The TCAS Computer Unit uses programming and configuration straps to select or deselect various TCAS functions. Refer to the notes in Figure 3-2 to determine applicable installation wiring.

The TCAS Computer Unit ARINC 600 connector layout is shown in Figure 3-3. The contact arrangement for the various connector plugs are shown in Figure 3-4 thru Figure 3-8. Figure 3-9 shows the connector pin layout for the DATA LOADER connector located on the front of the computer unit.

#### **B. TCAS Antennas**

The electrical installation for the TCAS antennas is shown in Figure 3-2. Figure 3-4 shows the TCAS computer contact arrangement for the top directional antenna and Figure 3-5 shows the TCAS computer contact arrangement for the bottom antenna.



**SYSTEM DESCRIPTION AND INSTALLATION MANUAL**  
**TCAS 3000 Traffic Alert and Collision Avoidance System**

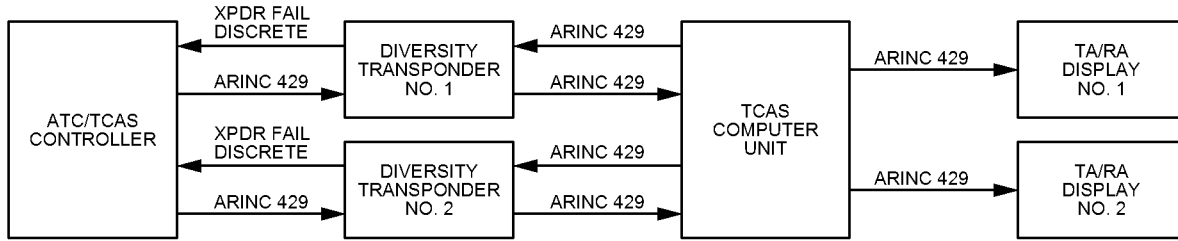

**ACSS/GABLES CONTROLLER WITH ACSS DIVERSITY TRANSPONDERS AND TCAS**

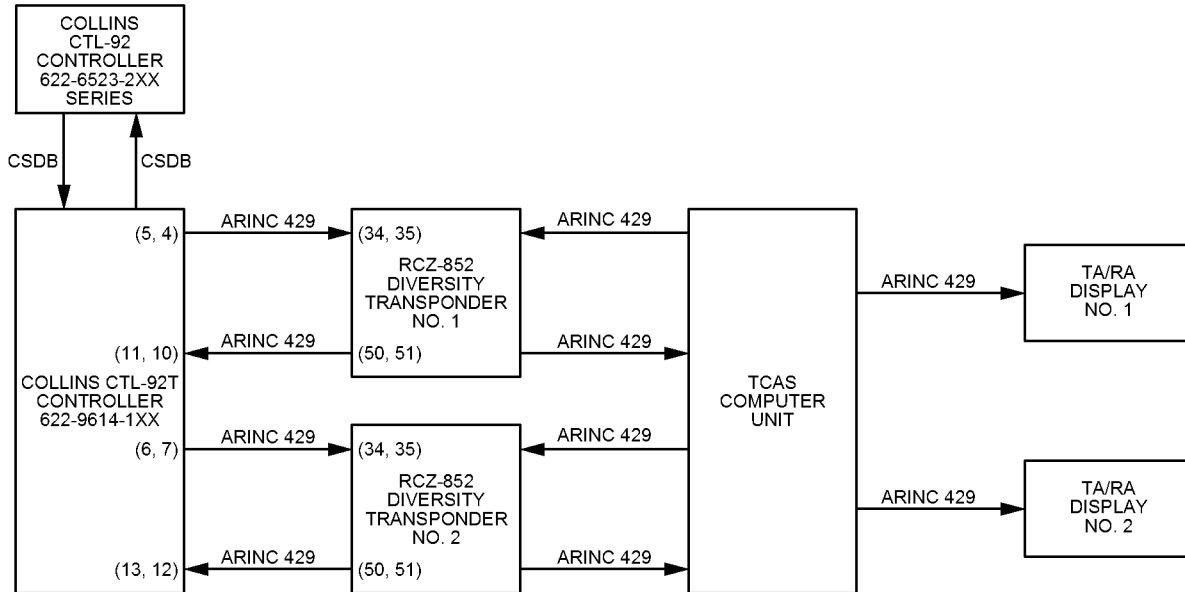

**COLLINS CONTROLLER WITH ACSS RCZ-852 DIVERSITY MODE S TRANSPONDERS AND TCAS**

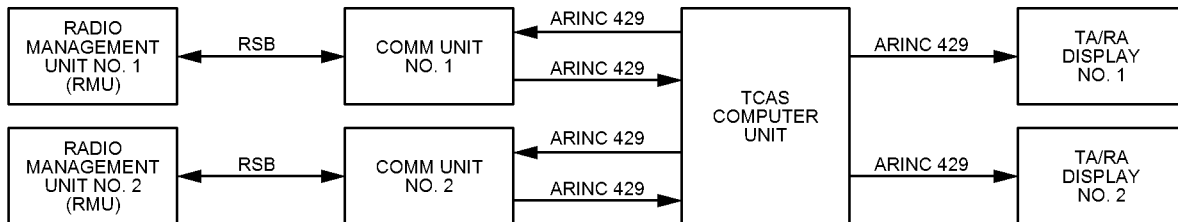

**HONEYWELL PRIMUS II RADIO SYSTEM AND TCAS**

ID-8005674-001

**Figure 3-1. Typical Installation Types**





**SYSTEM DESCRIPTION AND INSTALLATION MANUAL**  
**TCAS 3000 Traffic Alert and Collision Avoidance System**

**NOTES:**

1. TO ASSURE PROPER GROUNDING OF THIS SYSTEM, THE AIRCRAFT SURFACE TO WHICH ALL MOUNTINGS OR UNITS ARE ATTACHED MUST BE CLEAN BARE METAL. MOUNT TO AIRFRAME RESISTANCE SHALL BE 5 MICROHMS OR LESS.
2. UNLESS OTHERWISE SPECIFIED, ALL WIRES SHALL BE STRANDED #22 AWG.
3. ANTENNA COAX SHALL BE RG225 OR EQUIVALENT COAXIAL CABLE, PROVIDING A LOSS OF 2.5 +/- 0.5dB BETWEEN THE TCAS CU AND EACH TCAS ANTENNA PORT. FOR DIRECTIONAL ANTENNA COAXES, EACH COAX CABLE MUST ADDITIONALLY BE WITHIN 0.5dB OF THE OTHER COAXES.
4. MUTUAL SUPPRESSION COAX SHALL BE RG142, RG400, OR EQUIVALENT COAXIAL CABLE WHICH MEETS THE OPERATIONAL CHARACTERISTICS REQUIRED BY ARINC 735.
5. ALL ARINC 429 DATA BUS WIRES SHALL BE STRANDED #22 AWG TWISTED SHIELD WIRE. ALL OUTER SHIELDS SHALL BE TERMINATED TO THE AIRFRAME GROUND. UNSHIELDED PORTIONS OF THE CABLE AND SHIELD GROUND WIRES SHOULD BE KEPT TO A MINIMUM LENGTH TO MINIMIZE RF SUSCEPTIBILITY.
6. AIRCRAFT POWER INPUT:  
 ARE 115VAC AND 28VDC COMPATIBLE (SELECT ONE);  
 NOTE: WILL NOT BE DAMAGED IF BOTH 115VAC AND 28VDC INPUTS ARE CONNECTED SIMULTANEOUSLY. HOWEVER, THIS IS NOT RECOMMENDED.

**POWER CHARACTERISTICS ARE AS FOLLOWS:**

	(VAC)		(VDC)	
	NOMINAL	MINIMUM	NOMINAL	MINIMUM
OPERATING VOLTAGE	115Vrms	97Vrms	+27.5Vdc	+20.5Vdc
		134Vrms		+32.2Vdc
OPERATING FREQUENCY	NOMINAL 400Hz	MINIMUM 320Hz	MAXIMUM 480Hz	n/a
POWER CONSUMPTION (RT-950/-951)	STANDBY	55W	NOMINAL	65W
	MAXIMUM	85W		

7. BOTTOM ANTENNA CONNECTIONS:  
 IF AN OMNI-DIRECTIONAL ANTENNA IS INSTALLED, THE ANTENNA IS CONNECTED TO PORT P18-1 ONLY (0 DEGREE IN A DIRECTIONAL ANTENNA INSTALLATION). IF A DIRECTIONAL ANTENNA IS INSTALLED, ALL FOUR CONNECTIONS (P18/1,2,3,4) ARE USED.
8. DISCRETE INPUT GROUND/OPEN LOGIC LEVELS:  
 THE DISCRETE INPUTS EMPLOY A GROUND/OPEN LOGIC THRESHOLD. THE INPUTS HAVE THE FOLLOWING LOGIC THRESHOLD DEFINITIONS:  
 GROUND - VOLTAGE OF 0.0 TO 3.5 VDC FROM UNIT GROUND APPLIED TO INPUT OR RESISTANCE OF LESS THAN 10 OHMS TO UNIT GROUND APPLIED TO INPUT.  
 OPEN - VOLTAGE OF 18.5 TO 36 VDC FROM UNIT GROUND APPLIED TO INPUT OR RESISTANCE OF GREATER THAN 100K OHMS TO UNIT GROUND APPLIED TO INPUT.
9. OPERATES IN CONJUNCTION WITH ARINC 718 COMPATIBLE MODE-S TRANSPONDERS.
- 10a. DATA BUS IS HIGH SPEED ARINC 429, PROVIDING A BIT RATE OF 100 KILOBITS/SECOND.
- 10b. DATA BUS IS LOW SPEED ARINC 429, PROVIDING A BIT RATE OF 12.5 KILOBITS/SECOND.
11. CLIMB INHIBIT INPUT:  
 THE CLIMB INHIBIT INPUT IS A GROUND/OPEN TYPE DISCRETE. THE FEATURE PROVIDES INFORMATION TO THE TCAS CU WHETHER TO ASSUME THE AIRCRAFT'S INABILITY TO ACHIEVE A CLIMB RATE OF 1500 FPM. INPUTS ARE DESIGNED IN PAIRS BUT CAN BE WIRED AS A SINGLE INPUT OR IN CONJUNCTION WITH OTHER AIRCRAFT OPERATIONS TO ACHIEVE AIRFRAME CUSTOMIZATION OF THE CLIMB INHIBIT FEATURE. DISCRETE INPUTS SHOULD BE TIED TOGETHER IF ONLY ONE INPUT IS USED OR BOTH LEFT 'OPEN' IF THE CLIMB FUNCTION IS NOT REQUIRED. THE 1500 FPM CLIMB INHIBIT FUNCTION SHOULD BE ASSUMED WHENEVER ANY OF THE FOLLOWING COMBINATION OF INPUT CONDITIONS OCCUR:  
 CLIMB INHIBIT #1 AND #2 - GROUND (TRUE), OR,  
 CLIMB INHIBIT #3 AND #4 - GROUND (TRUE)

12. INCREASED CLIMB INHIBIT INPUT:  
 THE INCREASE CLIMB INHIBIT INPUT IS A GROUND/OPEN TYPE DISCRETE. THE FEATURE PROVIDES INFORMATION TO THE TCAS CU WHETHER TO ASSUME THE AIRCRAFT'S INABILITY TO ACHIEVE A CLIMB RATE OF 2500FPM. INPUTS ARE DESIGNED IN PAIRS BUT CAN BE WIRED AS A SINGLE INPUT OR IN CONJUNCTION WITH OTHER AIRCRAFT OPERATIONS TO ACHIEVE AIRFRAME CUSTOMIZATION OF THE CLIMB INHIBIT FEATURE. DISCRETE INPUTS SHOULD BE TIED TOGETHER IF ONLY ONE INPUT IS USED OR BOTH LEFT 'OPEN' IF THE INCREASED CLIMB INHIBIT FUNCTION IS NOT REQUIRED. THE 2500 FPM CLIMB INHIBIT FUNCTION SHOULD BE ASSUMED WHENEVER ANY OF THE FOLLOWING COMBINATION OF INPUT CONDITIONS OCCUR:  
 INCREASED CLIMB INHIBIT #1 AND #2 - GROUND (TRUE), OR,  
 INCREASED CLIMB INHIBIT #3 AND #4 - GROUND (TRUE)
13. ATTITUDE VALID DISCRETE INPUT:  
 ATTITUDE VALID IS A 28VDC/OPEN TYPE DISCRETE. THE FEATURE IS NOT UTILIZED IN THE RT-950/-951.
14. AIR/GROUND (WEIGHT-ON-WHEELS):  
 AIR/GROUND IS A GROUND/OPEN TYPE DISCRETE. LOGIC IS:  
 GROUND - AIRCRAFT ON GROUND  
 OPEN - AIRCRAFT AIRBORNE
15. MAGNETIC HEADING VALID DISCRETE:  
 MAGNETIC HEADING VALID IS A GROUND/OPEN TYPE DISCRETE. THE FEATURE IS NOT UTILIZED IN THE RT-950/-951.
16. RADIO ALTIMETER VALID DISCRETE:  
 RADIO ALTIMETER VALID IS A 28VDC/OPEN TYPE DISCRETE SUPPLIED BY THE ANALOG RADIO ALTIMETER. THIS IS A VALIDITY FLAG WHICH THE TCAS CU WILL LOOK AT FIRST IN DETERMINING WHICH TYPE OF RADIO ALTIMETER (ANALOG OR DIGITAL) IS VALID. LOGIC IS:  
 >18.5 VDC = VALID RADIO ALTITUDE AVAILABLE FROM SOURCE  
 OPEN = SOURCE NOT VALID
17. PERFORMANCE LIMIT DISCRETE:  
 PERFORMANCE LIMIT INPUT IS A GROUND/OPEN TYPE DISCRETE. THE DISCRETE PROVIDES TCAS CU WITH AN INPUT FROM THE FLIGHT MANAGEMENT COMPUTER/SYSTEM WHICH INDICATES THE AIRCRAFT CANNOT ACHIEVE A 1500 FPM CLIMB RATE. LOGIC IS:  
 GROUND - PERFORMANCE/CLIMB RATE IS NOT LIMITED; NO ACTION IS NEEDED ON OF THE TCAS CU  
 OPEN - PERFORMANCE/CLIMB RATE IS LIMITED WHEN AIRCRAFT IS ABOVE THE VALUE SET BY THE PROGRAM PINS (P1E-6E THRU P1E-6J)
18. LANDING GEAR STATUS DISCRETE:  
 LANDING GEAR INPUT IS A GROUND/OPEN TYPE DISCRETE PROVIDING THE TCAS CU WITH STATUS OF LANDING GEAR POSITION. THE LANDING GEAR DISCRETE INPUT SHOULD BE WIRED TO AIRCRAFT GEAR STATUS. LOGIC IS:  
 GROUND - AIRCRAFT ON GROUND  
 OPEN - LANDING GEAR RETRACTED
19. RA/TA DISPLAY STATUS DISCRETES:  
 RA/TA DISPLAY STATUS INPUTS ARE GROUND/OPEN TYPE DISCRETES WHICH PROVIDE THE FUNCTIONAL STATUS OF THE RA/TA DISPLAYS. IF THESE DISCRETES ARE NOT UTILIZED BY THE RA/TA DISPLAYS, THEY SHOULD BE GROUNDED TO AIRCRAFT GROUND, PROVIDING A CONTINUOUS "OPERATIONAL" STATUS OF THE RA/TA DISPLAYS TO THE TCAS CU.
20. RA DISPLAY STATUS DISCRETES:  
 RA DISPLAY STATUS INPUTS ARE GROUND/OPEN TYPE DISCRETES PROVIDING THE FUNCTIONAL STATUS OF THE RA DISPLAYS. IF THESE DISCRETES ARE NOT UTILIZED BY THE RA DISPLAYS, THEY SHOULD BE GROUNDED TO AIRCRAFT GROUND, PROVIDING A CONTINUOUS "OPERATIONAL" STATUS OF THE RA DISPLAYS TO THE TCAS CU.

21. AIRBORNE/PORTABLE DATA LOADER (ADL/PDL) DISCRETES:  
 ADL INPUTS ARE GROUND/OPEN TYPE DISCRETES WHICH SPECIFY WHAT TYPE OF DATA LOADER (ARINC 603 OR ARINC 615) IS ATTACHED. AN ACTIVE DISCRETE (SELECTED) IS LOGIC 1. GROUND. AN INACTIVE DISCRETE (NOT SELECTED) IS INDICATED BY OPEN CONDITION. LOGIC IS:  

P1F-6A	P2-18	P2-51/ P1F-6B	P2-52/ P1F-6C	P2-53/ P1F-6D	FUNCTION
GND	OPEN	GND	OPEN	OPEN	AIRBORNE ARINC 615 DATA LOADER (REAR CONNECTOR)
GND	OPEN	OPEN	GND	OPEN	AIRBORNE ARINC 603 DATA LOADER (REAR CONNECTOR)
OPEN	GND	GND	OPEN	OPEN	PORTABLE ARINC 615 DATA LOADER (FRONT CONNECTOR)
OPEN	GND	OPEN	GND	OPEN	PORTABLE ARINC 603 DATA LOADER (FRONT CONNECTOR)
-	-	-	-	GND	SW PART NUMBER IS OUTPUT
22. ADVISORY INHIBIT DISCRETES:  
 ADVISORY INHIBIT IS A GROUND/OPEN TYPE DISCRETE WHICH INHIBITS ALL ADVISORIES (TA AND RA), AURAL ALERT, AND VISUAL ALERTS OUTPUTS UNTIL ANOTHER HIGHER PRIORITY ANNOUNCEMENT/ALERT IS COMPLETED. AN OPEN AT ALL FOUR INPUTS INDICATES NORMAL ADVISORY/ALERT OPERATION. GROUNDED THE INPUT ACTIVATES THE FUNCTION. THE COMMAND MODES ARE:  

INPUT	MODE	PRIORITY	POSSIBLE SOURCE OF PRIORITY CONDITION
1	FORCE STANDBY (STRY)	1	OTHER AIRCRAFT SYSTEM
2	FORCE TA ONLY	2	GROUND PROXIMITY WARNING SYSTEM
3	FORCE TA ONLY	2	WINDSHEAR SYSTEM
4	FORCE TA ONLY	2	OTHER AIRCRAFT SYSTEM
23. TA DISPLAY ENABLE DISCRETE:  
 TA DISPLAY INPUT IS A GROUND/OPEN TYPE DISCRETE UTILIZED BY THE WEATHER RADAR DISPLAY TO PLACE THE RADAR IN A STANDBY MODE. LOGIC IS:  
 GROUND - TA DISPLAY ENABLED  
 OPEN - TA DISPLAY DISABLED
24. VISUAL ANNUNCIATOR SIGNALS:  
 VISUAL ANNUNCIATOR OUTPUTS ARE GROUND/OPEN TYPE DISCRETES UTILIZED TO OPERATE ANNUNCIATOR LIGHTS ON THE DISPLAYS. THE OUTPUTS ARE ACTIVATED WHENEVER A TA IS ISSUED. EACH OUTPUT REMAINS IN THE ACTIVATED STATE FOR THE DURATION OF ADVISORY UNLESS CANCELED BY THE ADVISORY/ANNUNCIATOR CANCEL INPUT P1E-30. ONLY ONE VISUAL ANNUNCIATOR DISCRETE OUTPUT IS ACTIVATED AT A TIME. LOGIC IS:  
 GROUND - VISUAL ANNUNCIATOR ACTIVATED; TA ISSUED.  
 OPEN - NO VISUAL ANNUNCIATOR ACTIVATED; NO TA ISSUED.
25. TCAS SYSTEM VALID DISCRETE:  
 TCAS SYSTEM VALID OUTPUT IS A GROUND/OPEN TYPE DISCRETE. TCAS SYSTEM VALID PROVIDES A TCAS SYSTEM HEALTH INDICATION TO OTHER AVIONICS SYSTEMS THAT MONITOR TCAS SYSTEM STATUS. THIS DISCRETE IS PROVIDED FOR RETROFIT APPLICATIONS WHERE TCAS SYSTEM HEALTH IS NOT OBTAINED ACROSS AN A429 BUS.  
 GROUND - NORMAL TCAS OPERATION  
 OPEN - TCAS FAULT PRESENT
26. RA DATA WORDS:  
 RA DATA OUTPUTS ARE GROUND/OPEN TYPE DISCRETES PROVIDING RESOLUTION ADVISORY INFORMATION TO THE ARINC 573 FLIGHT RECORDER. THE DISCRETES ARE PULLED UP TO +28V THROUGH AN INTERNAL 30 KOHM RESISTOR. LOGIC IS:  
 GROUND - ASSOCIATED BIT WITHIN THE ADVISORY FIELD OF THE RA OUTPUT WORD IS A "ONE".  
 OPEN - ASSOCIATED BIT WITHIN THE ADVISORY FIELD OF THE RA OUTPUT WORD IS A "ZERO".
27. CONNECTED TO AIRCRAFT GROUND IF UTILIZED.
28. PROGRAM PIN IS GROUNDED TO A DESIGNATED COMMON GROUND ON THE TCAS CU.

(NOTES CONTINUED ON SHEET 2)

Figure 3-2 (Sheet 1). TCAS System Interconnect Diagram



# SYSTEM DESCRIPTION AND INSTALLATION MANUAL

## TCAS 3000 Traffic Alert and Collision Avoidance System

(NOTES CONTINUED FROM SHEET 1)

**4.3** RA/TA BLOCK TRANSFER PROGRAM:  
RA/TA BLOCK TRANSFER PROGRAM PIN DETERMINES THE TYPE OF BLOCK TRANSFER THAT WILL BE MADE FROM THE TCAS CU TO THE TA/RA DISPLAYS. LOGIC IS:

GROUND - TCAS CU TRANSMITS IN HONEYWELL BCA EFIS FORMAT  
OPEN - TCAS CU TRANSMITS IN ARINC 735 FORMAT

**4.10** ALTITUDE LIMIT PROGRAM PINS:  
ALTITUDE LIMIT PROGRAM PINS SELECT THE 'CAN'T CLIMB' ALTITUDE IN 2000-FOOT SUMMATION INCREMENTS UP TO 62,000 FEET. THE ALTITUDE PROGRAM IS THE ALTITUDE AT WHICH THE AIRCRAFT IS NOT ABLE TO ACHIEVE A 0.25 G VERTICAL ACCELERATION TO A 1500 FPM CLIMB RATE FOR AN ALTITUDE GAIN OF 750 FEET ABOVE A CERTAIN ALTITUDE UNDER ALL CIRCUMSTANCES. THE 'CAN'T CLIMB' ALTITUDE IS SELECTED BY CONNECTING JUMPER WIRES FROM THE PROGRAM PINS (P1E-6E, 6F, 6G, 6H, 6J) TO THE PROGRAM COMMON (P1E-6K).

**4.1** GROUND DISPLAY MODE PROGRAM PIN:  
GROUND DISPLAY MODE PROGRAM PIN SELECTS THE TCAS DISPLAY MODE WHILE THE AIRCRAFT IS ON THE GROUND. PROGRAM COMMON FOR THIS PROGRAM PIN IS P1F-7K. THE LOGIC IS:

OPEN - TCAS DISPLAYS ONLY TRAFFIC; OPERATES IN TA ONLY MODE (AURAL AND VOICE INHIBITED) WHEN ON GROUND  
GROUND - TCAS PLACED IN STANDBY MODE WHEN ON GROUND

**4.2** DISPLAY ALL TRAFFIC PROGRAM PIN:  
DISPLAY ALL TRAFFIC PROGRAM PIN SELECTS EITHER THE TRAFFIC DISPLAY (RA, TA, PROX, AND OPTIONAL OTHER) MODE OR THE RA/TA ONLY DISPLAY MODE. PROGRAM COMMON FOR THIS PROGRAM PIN IS P1F-7K. LOGIC IS:

OPEN - ALL TRAFFIC DISPLAYED CONTINUOUSLY (TA, RA, PROX, AND OTHER)  
GROUND - RA/TA ONLY DISPLAY MODE SELECTED

**4.3** CABLE DELAY PROGRAM PINS:  
CABLE DELAY PROGRAM PINS ARE USED TO CONVEY TO THE TCAS CU THE AMOUNT OF DELAY DIFFERENTIAL BETWEEN THE TOP AND BOTTOM ANTENNA CABLES. PROGRAM COMMON FOR THESE PROGRAM PINS IS P1F-7K. THE THREE PINS PROVIDE THE FOLLOWING INFORMATION:

SIGNAL (P1F-7G)		MEANING	
OPEN		ADD TIME DELAY TO TOP	
GROUND		ADD TIME DELAY TO BOTTOM	

CABLE DELAY			
MSB	LSB		
(P1F-7H)	(P1F-7J)	DIFFERENTIAL DELAY (NSEC)	ADD (NSEC) IN TCAS
OPEN	OPEN	0-50	0
OPEN	GROUND	51-150	100
GROUND	OPEN	151-250	200
GROUND	GROUND	251-350	300

**4.4** TA/RA DISPLAY SYMBOL PROGRAM PINS:  
TA/RA DISPLAY SYMBOL PROGRAM PINS ARE USED TO ENCODE THE MAXIMUM NUMBER OF INTRUDER SYMBOLS TO BE PRESENTED ON TA DISPLAYS. THE NUMBER OF INTRUDER SYMBOLS TO BE DISPLAYED CAN VARY BETWEEN 0 AND 31, DEPENDING ON THE PROGRAMMING WHICH IS A SUMMATION OF THE SELECTED PINS. THE LOGIC IS:

OPEN - DISPLAY QUANTITY SELECTED  
GROUND - DISPLAY QUANTITY NOT SELECTED

**4.5** AUDIO TONE ENABLE PROGRAM PIN:  
AUDIO TONE ENABLE PROGRAM PIN DELAYS ALL VOICE ANNOUNCEMENTS BY ONE SECOND AND PRECEDES THEM BY A TONE. (RESERVED PIN ON -XX001 P/N UNITS). LOGIC IS:

OPEN - NO DELAYS OR TONES WILL OCCUR  
GROUND (TO P1F-7K) - ONE-SECOND DELAY IN ANNOUNCEMENTS WHICH ARE PRECEDED BY A TONE

**4.6** AUDIO LEVEL PROGRAM PINS:  
AUDIO LEVEL PROGRAM PINS CONTROL THE OUTPUT LEVELS OF BOTH SYNTHESIZED VOICE OUTPUTS (P1E-2F, 2G, 3F, 3G).

PIN (P1F-)		LOW LEVEL OUTPUT		HIGH LEVEL OUTPUT	
MSB	LSB	dBm	mV	dBm	V
7A	7C				
OPEN	OPEN	16	40	6	4
OPEN	OPEN	13	20	3	2
OPEN	GROUND	10	10	0	1
OPEN	GROUND	7	5	-3	0.5
GROUND	OPEN	4	2.5	-6	0.25
GROUND	OPEN	1	1.25	-9	0.125
GROUND	GROUND	-2	0.625	-12	0.0625
GROUND	GROUND	15	80	9	8

**4.7** SYNCHRS ARE NOT UTILIZED IN THE RT-950/-951.

**4.8** ANALOG RADIO ALTIMETER PROGRAM PINS. WHEN TCAS RECOGNIZES A VALID ANALOG RADIO ALTIMETER (SEE NOTE 16), THE TYPE OF INPUT WILL BE DETERMINED BY THE FOLLOWING PROGRAM PINS. ALL UNASSIGNED PROGRAM PIN COMBINATIONS ARE INVALID AND SHOULD NOT BE SELECTED. ALTIMETER TYPES AHV6, NR-AS-10A, LP1A AND APN-232C/A ARE NOT RECOGNIZED IN -XX001 AND -XX002 P/N UNITS.

PIN P1E-	12K	12J	12H	12B	ALTITUDE TYPE
OPEN	OPEN	OPEN	OPEN	OPEN	ARINC 552/552A
OPEN	OPEN	OPEN	GROUND	OPEN	COLLINS BCA
OPEN	OPEN	GROUND	OPEN	OPEN	METRIC ALT #1
OPEN	OPEN	GROUND	GROUND	OPEN	UNASSIGNED
OPEN	GROUND	OPEN	OPEN	OPEN	METRIC ALT #2
OPEN	GROUND	OPEN	GROUND	OPEN	UNASSIGNED
OPEN	GROUND	GROUND	OPEN	OPEN	METRIC ALT #3
OPEN	GROUND	GROUND	GROUND	OPEN	UNASSIGNED
GROUND	OPEN	OPEN	OPEN	OPEN	METRIC ALT #4
GROUND	OPEN	OPEN	GROUND	OPEN	UNASSIGNED
GROUND	OPEN	GROUND	OPEN	OPEN	MIL AHV6(LINEAR)
GROUND	OPEN	GROUND	GROUND	OPEN	MIL AHV6(CLG)
GROUND	GROUND	OPEN	OPEN	OPEN	MIL NR-AS-10A(ALT)
GROUND	GROUND	OPEN	GROUND	OPEN	MIL APN-232 CARA
GROUND	GROUND	GROUND	OPEN	OPEN	MIL LP1A
GROUND	GROUND	GROUND	GROUND	OPEN	MIL NR-AS-10A(CURVE FIT)

THE RADIO ALTITUDE OF THE AIRCRAFT IS DEFINED BY THE FOLLOWING EQUATIONS:

**ARINC 552/552A**  
 $-20 < H \leq 480$  FEET, VOLTAGE =  $0.02 \cdot (H + 20)$  (VDC)  
 $480 < H \leq 2500$  FEET, VOLTAGE =  $10.4 + \ln((H+20)/500)$  (VDC)  
 (H=RADIO ALTITUDE IN FEET)  
 MAXIMUM VOLTAGE OUTPUT IS 26.2 VDC AT ANY HEIGHT ABOVE 2500 FEET.

**COLLINS BCA**  
 $-20 < H \leq 500$  FEET, VOLTAGE =  $0.02 \cdot (H + 20)$  (VDC)  
 $500 < H \leq 2500$  FEET, VOLTAGE =  $10.4 + 0.003 \cdot (H - 500)$  (VDC)  
 (H=RADIO ALTITUDE IN FEET)  
 MAXIMUM VOLTAGE OUTPUT IS 26.2 VDC AT ANY HEIGHT ABOVE 2500 FEET.

**METRIC ALT #1-4**  
 #1:  $0 < H \leq 1000$  METERS, VOLTAGE =  $0.025 \cdot H$  (VDC)  
 #2:  $0 < H \leq 1000$  METERS, VOLTAGE =  $0.020 \cdot H$  (VDC)  
 #3:  $0 < H \leq 1500$  METERS, VOLTAGE =  $0.020 \cdot H$  (VDC)  
 #4:  $0 < H \leq 750$  METERS, VOLTAGE =  $0.050 \cdot H$  (VDC)  
 (H=RADIO ALTITUDE IN METERS)

**AHV-6 LINEAR**  
 0 TO 25 VDC, H = (VOLTAGE + 200) - 20  
 (VOLTAGE IN VOLTS, H = RADIO ALTITUDE IN FEET)  
**AHV-6 LOG**  
 0 TO 10.4 VDC, H = (VOLTAGE + 50) - 20  
 $> 10.4$  TO  $18.09$  VDC, H =  $\exp((0.1429 \cdot \text{VOLTAGE}) + 4.7289)$   
 $> 18.09$  TO  $25$  VDC, H =  $695 \cdot \exp((0.2332 \cdot \text{VOLTAGE}) + 2.1111)$   
 (VOLTAGE IN VOLTS, H = RADIO ALTITUDE IN FEET)

**APN 232**  
 0 TO 27 VOLTS, H = VOLTAGE + 200  
 (VOLTAGE IN VOLTS, H = RADIO ALTITUDE IN FEET)  
**LP1A**

1 TO 9 VOLTS, H = (VOLTAGE - 50) - 50  
 $> 9$  TO 21 VOLTS, H = (VOLTAGE - 383.14) - 3048  
 (VOLTAGE IN VOLTS, H = RADIO ALTITUDE IN FEET)

**NR-AS-10A (ALTERNATE)**  
 0 TO 1.2 VOLTS, H = VOLTAGE + 2105.7  
 (VOLTAGE IN VOLTS, H = RADIO ALTITUDE IN FEET)

**NR-AS-10A (CURVE FIT)**  
 $0 \text{ TO } 18.1 \text{ VOLTS: } H = ((0.0833 \cdot \text{VOLTAGE}^4) + (-1.8887 \cdot \text{VOLTAGE}^3) + (15.5169 \cdot \text{VOLTAGE}^2) + (-21.9374 \cdot \text{VOLTAGE}) + 14.8097)$   
 (VOLTAGE IN VOLTS, H = RADIO ALTITUDE IN FEET)

**4.9** RADIO ALTIMETER ARINC 429 INPUTS:  
ARINC 429 ALTITUDE INPUTS ARE AVAILABLE FROM ARINC 707 DIGITAL RADIO ALTIMETERS VIA LOW SPEED BUSES.

**4.10** AIRCRAFT TYPE PROGRAM PINS:  
AIRCRAFT TYPE PROGRAM PINS ARE USED TO DESIGNATE THE AIRCRAFT MANUFACTURER (AIR TRANSPORT CUSTOMERS ONLY) FOR MAINTENANCE SUPPORT FUNCTIONALITY.

AIRCRAFT PROGRAM PINS	DESCRIPTION
<b>P6-12D</b>	
OPEN	ALL OTHER AIRFRAMES INCLUDING BCA AIRCRAFT
OPEN	BOEING
GROUND	MC DONALD DOUGLAS
GROUND	AIRBUS

**4.11** SYNTHESIZED VOICE OUTPUTS:  
SYNTHESIZED VOICE IS PROVIDED IN TWO ANALOG OUTPUTS; AN 8-OHM (UP TO 8W RMS) FOR COCKPIT SPEAKERS, AND A 600-OHM (UP TO 80W RMS) INTO AN AUDIO DISTRIBUTION SYSTEM. REFERENCE NOTE 36 FOR AUDIO LEVEL PROGRAMMING.

**4.12** PIN CONNECTED TO FRONT PANEL PORTABLE DATA LOADER (PDL) CONNECTOR.

**4.13** DISCRETE OPERATES AS STANDARD GROUND/OPEN INPUT OR OUTPUT.

**4.14** CENTRAL FAULT DISPLAY SYSTEM (CFDS):  
CENTRAL FAULT DISPLAY SYSTEM IS GENERIC NOMENCLATURE FOR THE MAINTENANCE DATA/COMPUTER INTERFACE. ONBOARD MAINTENANCE COMPUTERS MAY CONNECT TO THESE INTERFACES TO PROVIDE ACTIVE MAINTENANCE DATA AS REQUIRED BY AIRFRAME TYPE. REFERENCE NOTE 42 FOR PROGRAMMING PINS REQUIREMENTS BY AIRFRAMER.

**4.15** THE RT-950/-951 HAS SEPARATE RECEIVER BUSES AND SEPARATE DATA LOADER ENABLE DISCRETE INPUTS TO SUPPORT SIMULTANEOUSLY CONNECTIONS TO AN ADL AND PDL.

**4.16** FLIGHT DATA RECORDER ARINC 429 AND EXTENDED MAINTENANCE LOG PROGRAM PIN. THE LOGIC IS:

OPEN - FLIGHT DATA RECORDER NOT UTILIZED NORMAL RA DISPLAY BUS OPERATION  
GROUND - FLIGHT DATA OUTPUT AS HIGH SPEED ARINC 429 DATA ON RA DISPLAY #1 AND #2 BUSES (NOTE: NORMAL OPERATION IS LOW SPEED). NORMAL RA DISPLAY BUS OPERATION IS NOT AVAILABLE

**4.17** RS-232 DATA INPUT/OUTPUT:  
RS-232 DATA CONNECTION IS UTILIZED FOR COMMUNICATION WITH PORTABLE MAINTENANCE COMPUTERS DURING UNIT MAINTENANCE AND TROUBLESHOOTING ACTIVITIES. THE MAINTENANCE LOG AND RA EVENT LOG MAY BE DOWNLOADED VIA THIS CONNECTION. A COMMON (GROUND) LINE SHOULD BE USED BETWEEN THE TWO COMPUTERS. RT-950/-951 HAS TWO COMMON LINES AVAILABLE (P2-48 AND P2-49) FOR THIS PURPOSE.

**4.18** ANTENNA INSTALLATION:  
ALL L-BAND ANTENNAS (TCAS, UHF, ETC.) MUST BE SEPARATED BY AT LEAST 20 INCHES, WITH 60 INCHES PREFERRED.

**4.19** DISCRETE OUTPUT GROUND/OPEN LOGIC LEVELS:  
THE DISCRETE OUTPUTS EMPLOY A GROUND/OPEN LOGIC THRESHOLD THE OUTPUTS HAVE THE FOLLOWING LOGIC THRESHOLD DEFINITIONS:

GROUND - PORT CAPABLE OF SINKING AT LEAST 20 MILLIAMPERES OF CURRENT  
OPEN - VOLTAGE OF 18.5 TO 35 VDC FROM UNIT GROUND APPLIED TO OUTPUT OR RESISTANCE OF GREATER THAN 100,000 OHMS TO UNIT GROUND APPLIED TO OUTPUT

**4.20** 422 RECORDER 125 KHZ/EXTERNAL PROGRAM PIN:  
422 RECORDER 125 KHZ/EXTERNAL PROGRAM PIN IS USED TO DESIGNATE INTERNAL OR EXTERNAL RECORDER CLOCK OPERATION. LOGIC IS:

GROUND - EXTERNAL RECORDER CLOCK OPERATION  
OPEN - 125KHZ INTERNAL RECORDER CLOCK OPERATION

**4.21** FLIGHT RECORDER DATA AND INTERNAL 125 KHZ CLOCK REFERENCE OUTPUTTED ON THESE BUSES.

**4.22** 422 RECORDER DISABLE PROGRAM PIN:  
422 RECORDER DISABLE PROGRAM PIN ENABLES OR DISABLES THE 422 DATA RECORDER FUNCTION. THE PROGRAM PIN IS ACTIVATED EXTERNALLY VIA THE FLIGHT DATA RECORDER. LOGIC IS:

GROUND - DISABLE 422 RECORDER  
OPEN - ENABLE 422 RECORDER

**4.23** COMMUNICATION AND (EXTERNAL) CLOCKING FROM THE RS-422 FLIGHT DATA RECORDER.

**4.24** PIN CONNECTED TO REAR UNIT ARINC 600 CONNECTOR.

**4.25** WIRING REQUIREMENT IS STRANDED #20 AWG.

**4.26** WIRING REQUIREMENT IS STRANDED #16 AWG.

**4.27** ALL SYNTHESIZED VOICE (AUDIO) WIRES SHALL BE STRANDED #20 OR #22 AWG TWISTED SHIELDED WIRE. ALL OUTER SHIELDS SHALL BE TERMINATED TO THE AIRFRAME GROUND. UNSHIELDED PORTIONS OF THE CABLE AND SHIELD GROUND WIRES SHOULD BE KEPT TO A MINIMUM LENGTH TO MINIMIZE RF SUSCEPTIBILITY.

TCAS 3000  
INTERCONNECT DIAGRAM SHEET NO. 2

ID-8005676-001 E7517902-2-C

Figure 3-2 (Sheet 2). TCAS System Interconnect Diagram



**SYSTEM DESCRIPTION AND INSTALLATION MANUAL**  
 TCAS 3000 Traffic Alert and Collision Avoidance System

(NOTES CONTINUED FROM SHEET 2)

- 6.0 RA DISPLAY TEST INHIBIT PROGRAM:  
 RA DISPLAY TEST INHIBIT PROGRAM DETERMINES IF RA DISCRETE MONITORING DURING SELF-TEST WILL BE INHIBITED. LOGIC IS:  
 GROUND - RA DISCRETE SELF MONITORING INHIBITED.  
 OPEN - RA DISCRETE MONITORED DURING SELF-TEST.
- 6.1 SELF-TEST INHIBIT PROGRAM:  
 SELF-TEST INHIBIT PROGRAM PIN DETERMINES IF SELF-TEST WILL BE INHIBITED WHILE AIRBORNE. LOGIC IS:  
 OPEN - SELF-TEST ENABLED WHILE AIRBORNE.  
 GROUND - SELF-TEST INHIBITED WHILE AIRBORNE.
- 6.2 TCAS CHASSIS AND SIGNAL GROUND PINS SHOULD USE THE SAME AWG WHICH IS USED FOR THE POWER CONNECTIONS. SEE NOTES 57 AND 58.
- ~~6.3~~
- 6.4 TRAFFIC DISPLAY OF FLIGHT ID. ALLOWS FLIGHT IDENTIFICATION FROM TRANSPONDER TO BE OUTPUT ON TRAFFIC DISPLAY BUSES.  
 GROUND - FLIGHT ID DISPLAY ENABLED  
 OPEN - FLIGHT ID DISPLAY DISABLED
- 6.5 MALE VOICE PROGRAM. AUDIO ANNUNCIATIONS ARE SELECTABLE FOR EITHER MALE OR FEMALE GENDERS. (RESERVED PIN ON -XX001 AND -XX002 P/N UNITS).  
 GROUND - MALE VOICE SELECTED  
 OPEN - FEMALE VOICE SELECTED
- 6.6 OPTION PARITY PROGRAM. SET ACCORDING TO THE PARITY OF THE PROGRAM PINS P1E-10G, 10H, 10J, 10K, 11A, 11B, 11C, 11D. COUNT THE NUMBER OF PINS IN THIS GROUP WHICH ARE GROUNDED TO DETERMINE PARITY. (RESERVED PIN ON -XX001 P/N UNITS).  
 GROUND - NUMBER OF PINS WHICH ARE GROUNDED IN THE GROUP IS AN ODD NUMBER  
 (1,3,5,7)  
 OPEN - NUMBER OF PINS WHICH ARE GROUNDED IN THE GROUP IS AN EVEN NUMBER  
 (0,2,4,6,8)
- 6.7 CANCEL DISCRETE. ALLOWS AUDIO AND VISUAL ALERTS TO BE CANCELLED. (RESERVED PIN ON -XX001 P/N UNITS)  
 GROUND - AURAL AND VISUAL ALERTS ARE ALLOWED TO BE CANCELLED.  
 OPEN - AURAL AND VISUAL ALERTS ARE NOT ALLOWED TO BE CANCELLED.
- 6.8 ADS-B SURVEILLANCE PROGRAM PIN. ENABLES PASSIVE SURVEILLANCE USING ADS-B DF-17 EXTENDED SQUITTERS. (RESERVED PIN ON -XX001 AND -XX002 P/N UNITS).  
 GROUND - ADS-B SURVEILLANCE ENABLED.  
 OPEN - ADS-B SURVEILLANCE DISABLED.
- 6.9 AURAL ADVISORY DISCRETE OUTPUTS:  
 AURAL ADVISORY DISCRETE OUTPUTS ARE GROUND/OPEN TYPE DISCRETES UTILIZED TO CONTROL EXTERNAL EQUIPMENT WHICH SHALL GENERATE TONES THAT ACCOMPANY TCAS ADVISORIES. THE OUTPUTS ARE ACTIVATED WHENEVER A CORRECTIVE, PREVENTATIVE OR TRAFFIC ADVISORY IS ISSUED. EACH OUTPUT SHALL REMAIN ACTIVE FOR THE DURATION OF THE SYNTHESIZED VOICE UNLESS CANCELLED BY THE ADVISORY/ANNUNCIATOR CANCEL INPUT P1E-3D. ONLY ONE AURAL ADVISORY DISCRETE OUTPUT SHALL BE ACTIVATED AT A TIME. THE CORRECTIVE AND PREVENTATIVE DISCRETES ARE MUTUALLY EXCLUSIVE AND THE TA OUTPUT SHALL BE INHIBITED IF EITHER THE CORRECTIVE OR PREVENTATIVE OUTPUT IS ACTIVE.  
 LOGIC IS:  
 GROUND - AURAL ADVISORY ACTIVATED.  
 OPEN - NO AURAL ADVISORY ACTIVATED.
- 7.0 RADIO ALTIMETER TYPE LPIA:  
 FOR RADIO ALTIMETER TYPE LPIA ONLY, THE ANALOG DATA OUTPUT SHALL BE CONNECTED TO P1E-2H(+) AND P1E-2J(-). THE ANALOG DATA RELIABILITY SIGNAL SHALL BE CONNECTED TO P1F-3A(+) AND P1F-3B(-). ADDITIONALLY BOTH RADIO ALTIMETER VALID DISCRETES P1E-2K AND P1F-3C MUST BE SET TO GREATER THAN +/-22 VDC.

TCAS 3000

INTERCONNECT DIAGRAM SHEET NO. 3

ID-8005677-001 E7517902-3-C

Figure 3-2 (Sheet 3). TCAS System Interconnect Diagram



**SYSTEM DESCRIPTION AND INSTALLATION MANUAL**  
**TCAS 3000 Traffic Alert and Collision Avoidance System**

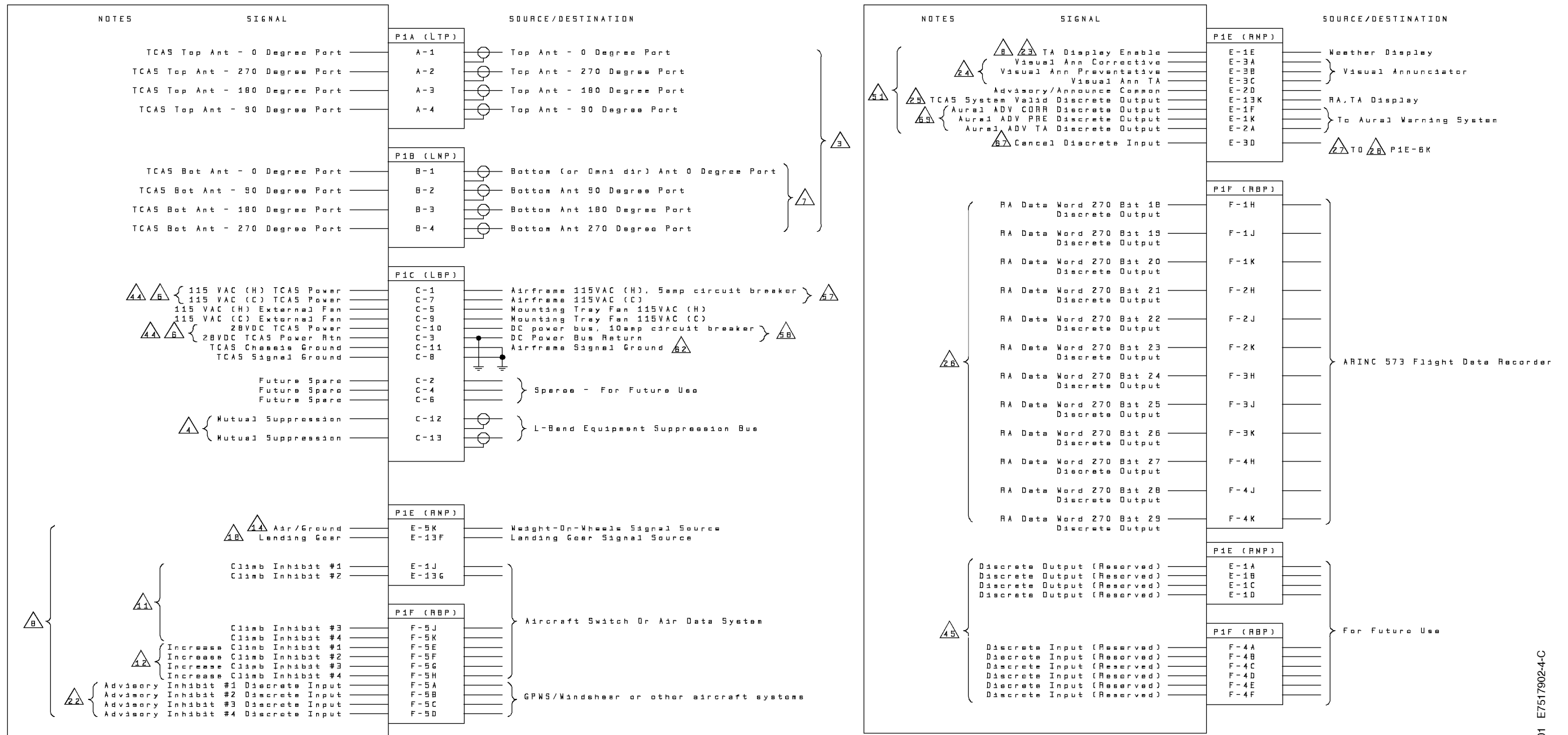



**SYSTEM DESCRIPTION AND INSTALLATION MANUAL**  
 TCAS 3000 Traffic Alert and Collision Avoidance System

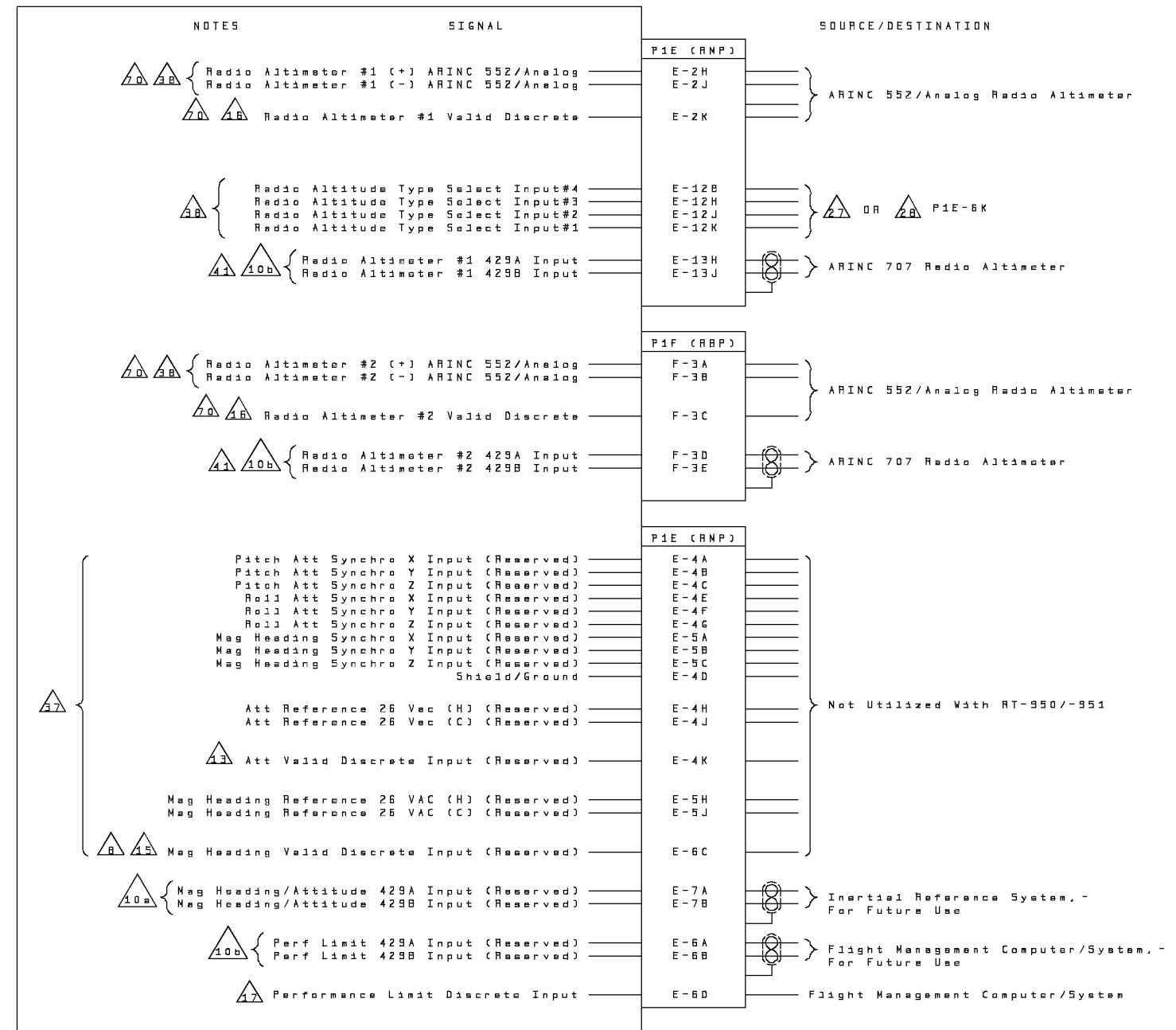
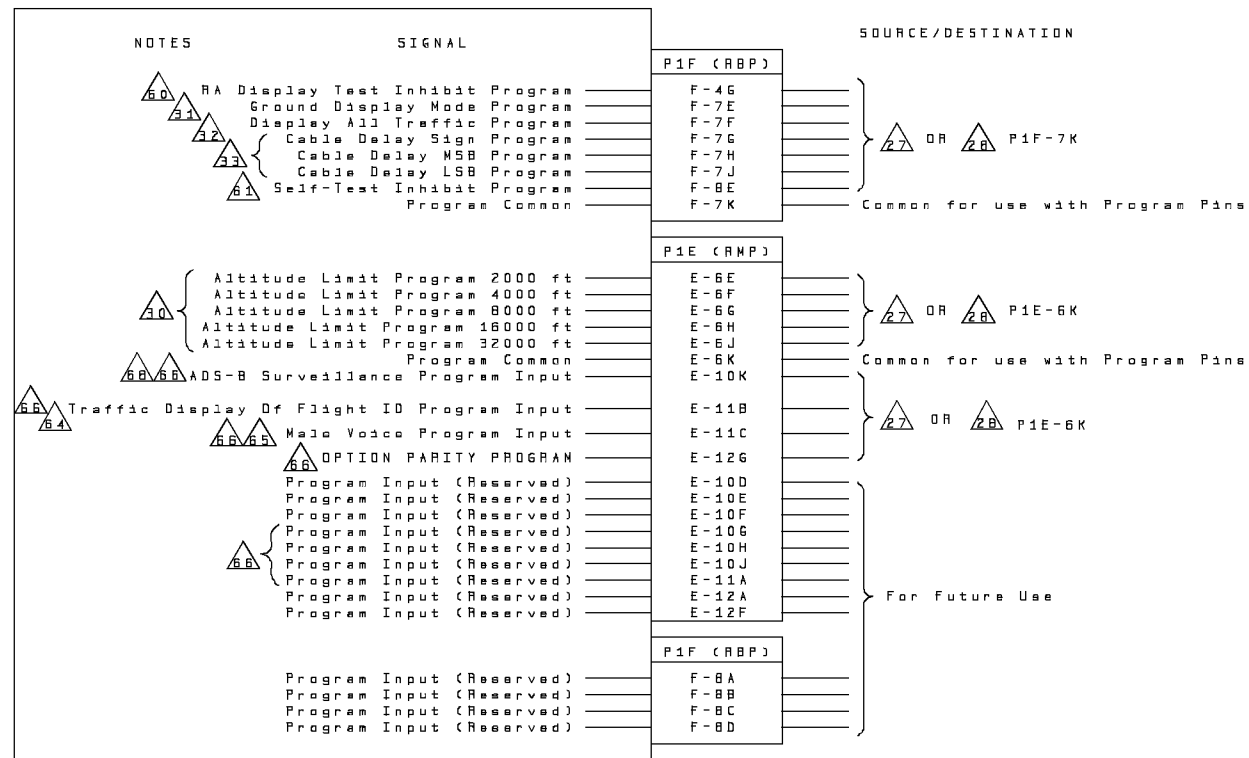

TCAS 3000

INTERCONNECT DIAGRAM SHEET NO. 5

Figure 3-2 (Sheet 5). TCAS System Interconnect Diagram





**SYSTEM DESCRIPTION AND INSTALLATION MANUAL**  
TCAS 3000 Traffic Alert and Collision Avoidance System

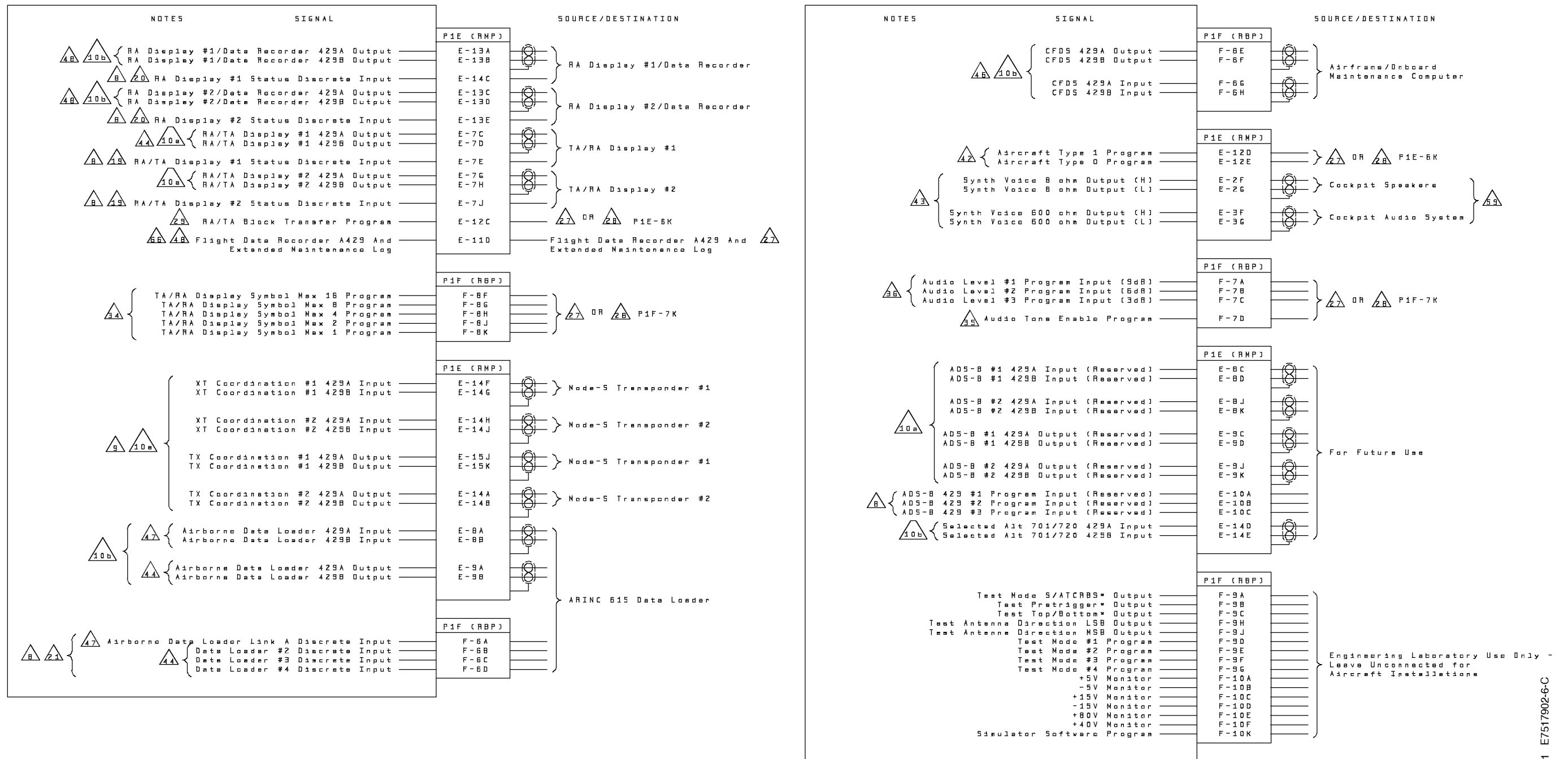

TCAS 3000

INTERCONNECT DIAGRAM SHEET NO. 6

Figure 3-2 (Sheet 6). TCAS System Interconnect Diagram



**SYSTEM DESCRIPTION AND INSTALLATION MANUAL**  
TCAS 3000 Traffic Alert and Collision Avoidance System

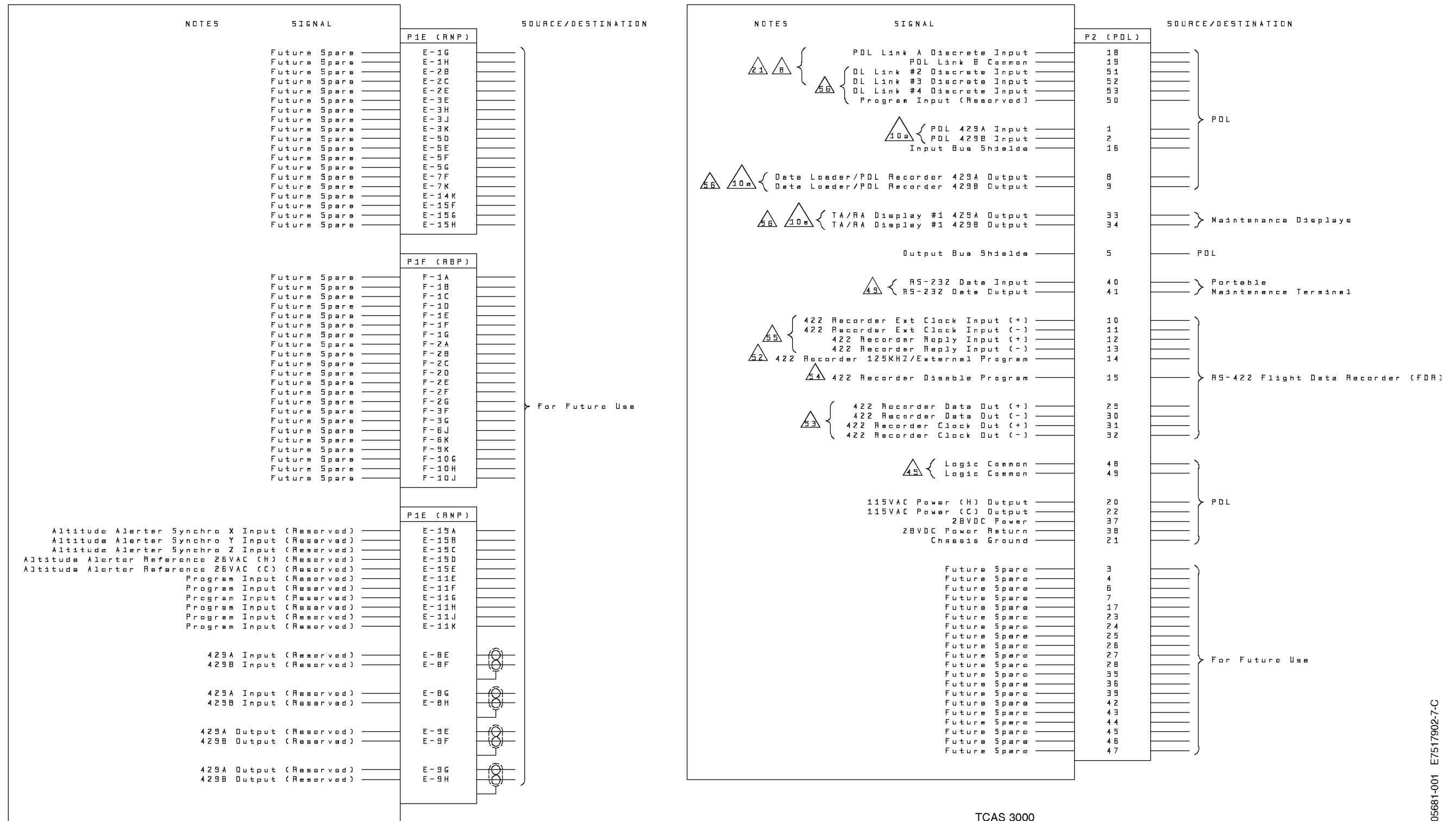

TCAS 3000  
INTERCONNECT DIAGRAM SHEET NO. 7

Figure 3-2 (Sheet 7). TCAS System Interconnect Diagram



**SYSTEM DESCRIPTION AND INSTALLATION MANUAL**  
TCAS 3000 Traffic Alert and Collision Avoidance System

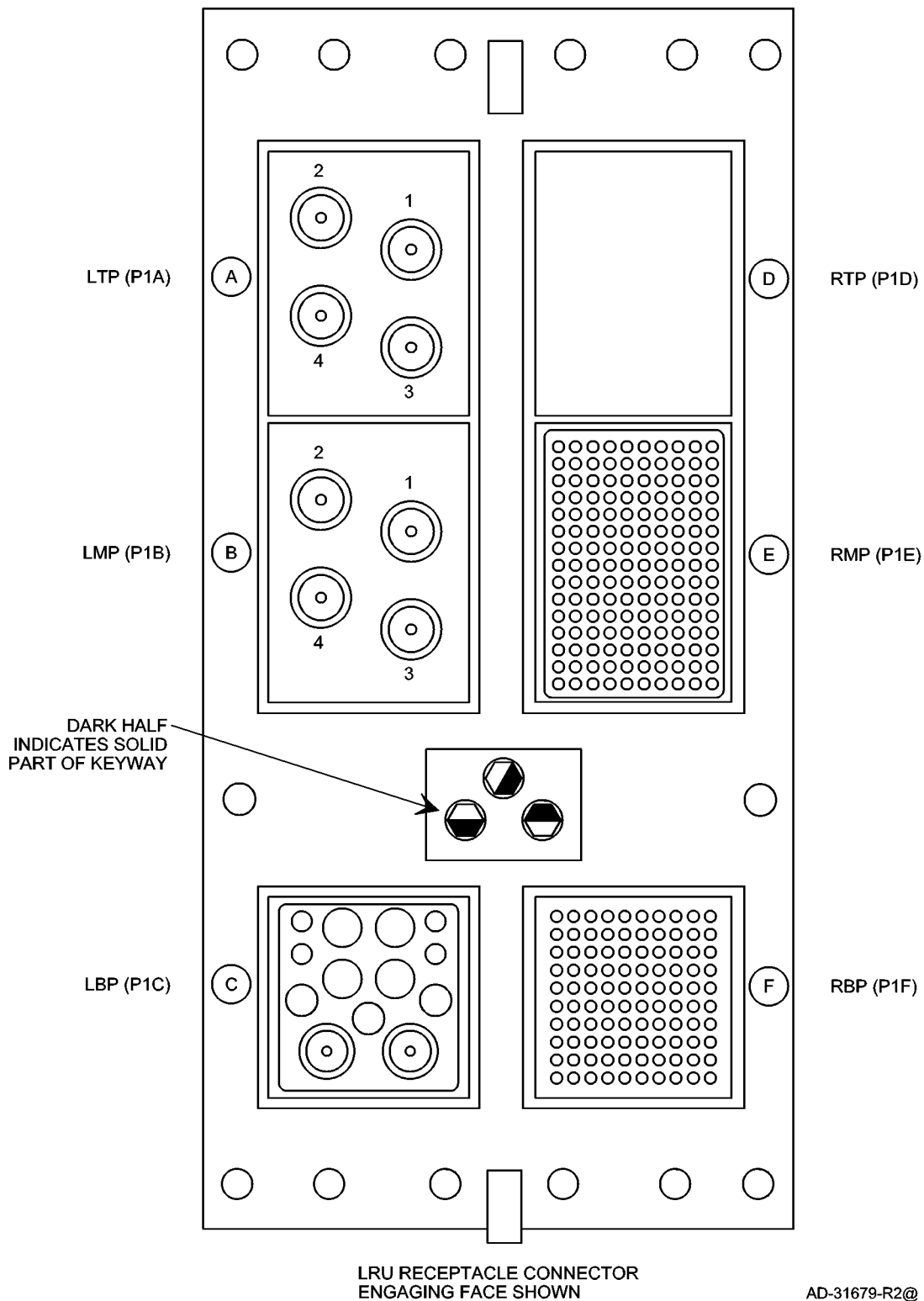
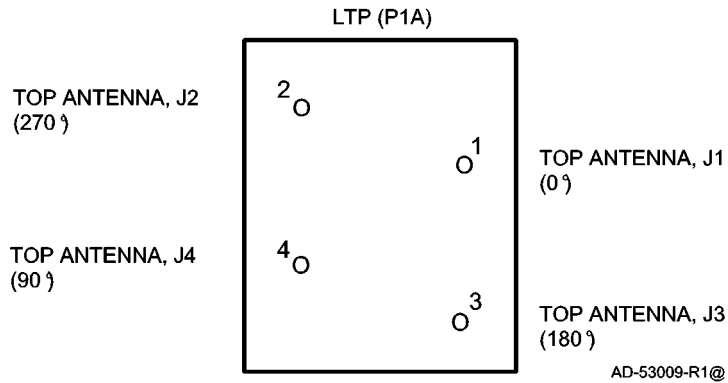

**Figure 3-3. TCAS 3000 Computer Unit ARINC 600 Connector (P1) Layout**





**SYSTEM DESCRIPTION AND INSTALLATION MANUAL**  
 TCAS 3000 Traffic Alert and Collision Avoidance System



**Figure 3-4. Contact Arrangement for CU Left Top Plug (LTP) Insert**

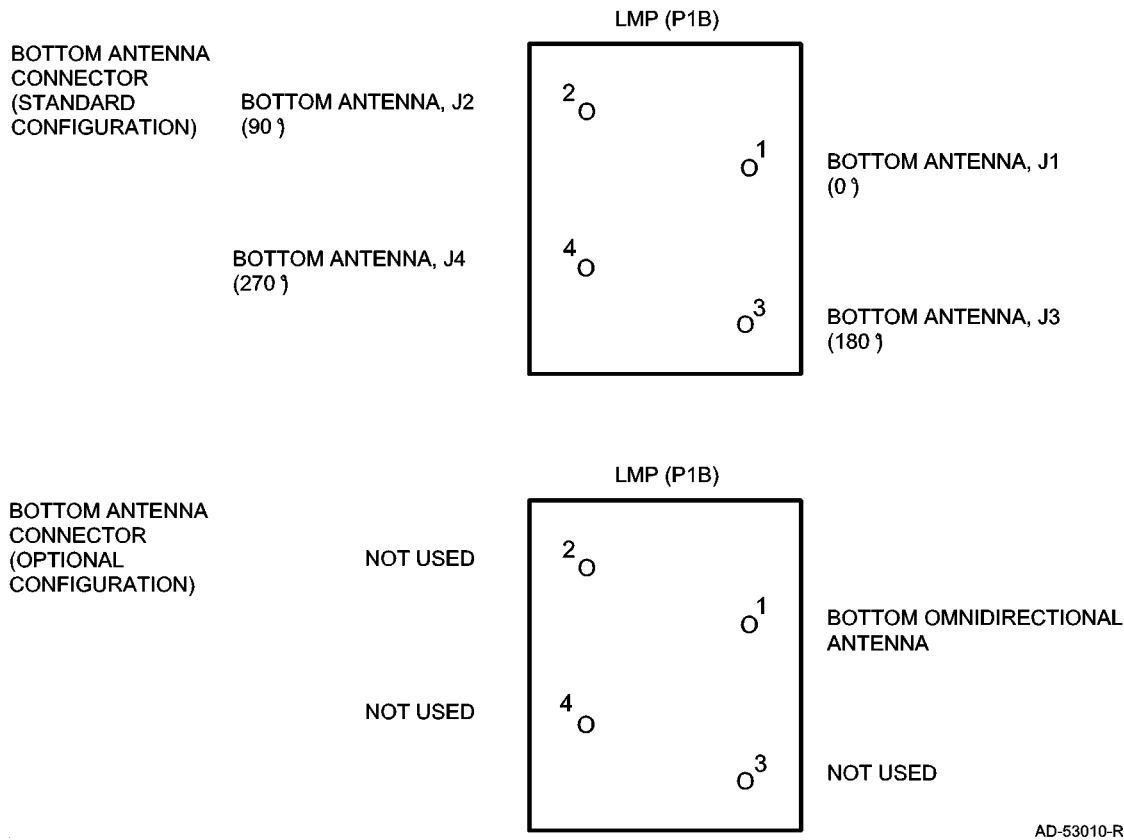

**Figure 3-5. Contact Arrangement for CU Left Middle Plug (LMP) Insert**



**SYSTEM DESCRIPTION AND INSTALLATION MANUAL**  
TCAS 3000 Traffic Alert and Collision Avoidance System

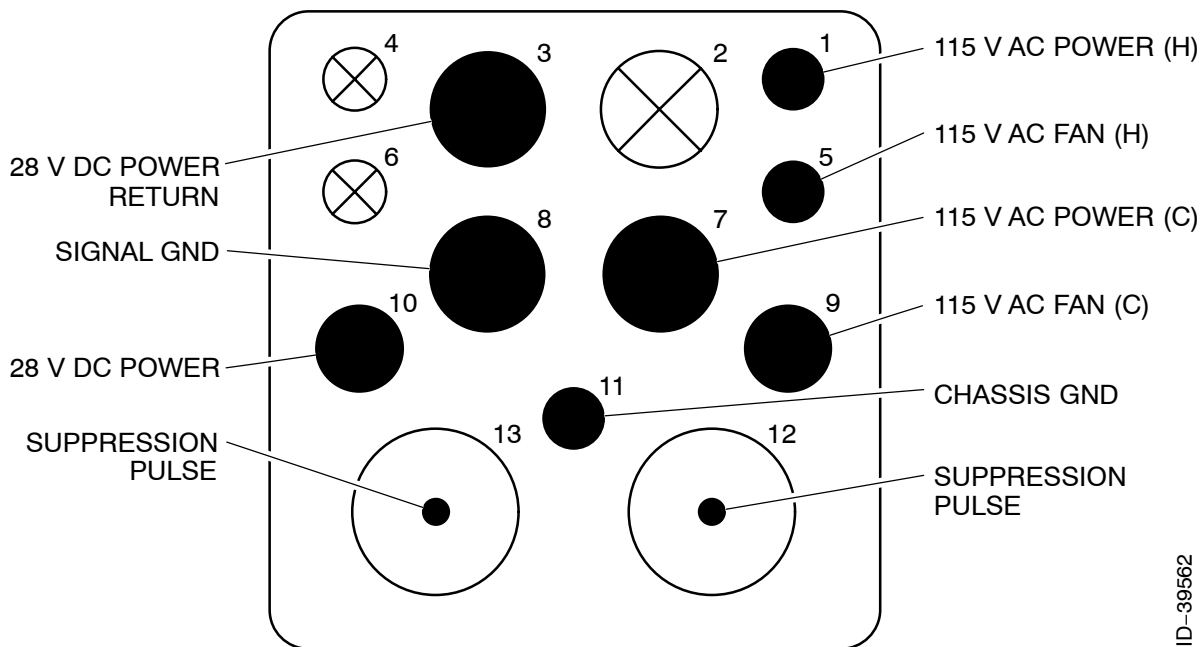

ID-39562

**Figure 3-6. Contact Arrangement for Left Bottom Plug (LBP) Insert**



## SYSTEM DESCRIPTION AND INSTALLATION MANUAL

### TCAS 3000 Traffic Alert and Collision Avoidance System

		RIGHT MIDDLE INSERT (RMP):									
		A	B	C	D	E	F	G	H	J	K
1		-- RESERVED FOR DISCRETE OUTPUTS -- <input type="radio"/>				TA DISP ENABLE <input type="radio"/> DISC OUT	AURAL ADV CORR <input type="radio"/> DISC OUT*	RESERVED <input type="radio"/>	RESERVED <input type="radio"/>	CLIMB INHIB NO. 1 <input type="radio"/> DISC IN	AURAL ADV PRE <input type="radio"/> DISC OUT*
2	AURAL ADV TA <input type="radio"/> DISC OUT*	RESERVED <input type="radio"/>	RESERVED <input type="radio"/>	ADVISORY ANNOUNCE <input type="radio"/> COMMON	FUTURE <input type="radio"/> SPARE	SYNTH VOICE OUT 8 OHMS <input type="radio"/> H <input type="radio"/> L		RADIO ALTIMETER NO. 1 INPUT ARINC 552/ANALOG <input type="radio"/> + <input type="radio"/> - <input type="radio"/> VALID			
3	VISUAL ANN CORR <input type="radio"/> DISC OUT	VISUAL ANN PRE <input type="radio"/> DISC OUT	VISUAL ANN TA <input type="radio"/> DISC OUT	CANCEL <input type="radio"/> DISC IN*	FUTURE <input type="radio"/> SPARE	SYNTH VOICE OUT 600 OHMS <input type="radio"/> H <input type="radio"/> L		FUTURE <input type="radio"/> SPARE	RESERVED <input type="radio"/>	RESERVED <input type="radio"/>	
4	RESERVED <input type="radio"/>	RESERVED <input type="radio"/>	RESERVED <input type="radio"/>	SHIELD <input type="radio"/> GROUND	RESERVED <input type="radio"/>	RESERVED <input type="radio"/>	RESERVED <input type="radio"/>	RESERVED <input type="radio"/>	RESERVED <input type="radio"/>	RESERVED <input type="radio"/>	
5	RESERVED <input type="radio"/>	RESERVED <input type="radio"/>	RESERVED <input type="radio"/>	RESERVED <input type="radio"/>	ADS-B PGM INPUT <input type="radio"/> INTRUDER GP BUS FILE ENABLE <input type="radio"/> SPARE			RESERVED <input type="radio"/>	RESERVED <input type="radio"/>	AIR/GND <input type="radio"/> DISC IN	
6	-- RSVD PERF LIMIT -- 429 LS IN <input type="radio"/> A <input type="radio"/> B		RSVD MAG HDG VALID <input type="radio"/> DISC IN	PERF LIMIT <input type="radio"/> DISC IN	-- AIRCRAFT ALTITUDE LIMIT PROGRAM PINS -- <input type="radio"/> 2,000 <input type="radio"/> 4,000 <input type="radio"/> 8,000 <input type="radio"/> 16,000 <input type="radio"/> 32,000					PROGRAM <input type="radio"/> COMMON	
7	RSVD MAG HDG/ATT 429 HS IN <input type="radio"/> A <input type="radio"/> B	-- TA/RA DISPLAY NO. 1 -- 429 HS OUT <input type="radio"/> A <input type="radio"/> B			STATUS <input type="radio"/> DISC IN	FUTURE <input type="radio"/> SPARE	-- TA/RA DISPLAY NO. 2 -- 429 HS OUT <input type="radio"/> A <input type="radio"/> B			DISC IN	FUTURE <input type="radio"/> SPARE
8	- DATA LOADER - 429 HS IN <input type="radio"/> A <input type="radio"/> B		TA/RA DISP CONTROL A429 IN #1 <input type="radio"/> A <input type="radio"/> B		RESERVED FOR 429 BUS INPUT <input type="radio"/> A <input type="radio"/> B		TA/RA DISP CONTROL A429 IN #2 <input type="radio"/> A <input type="radio"/> B		RSVD ADS-B NO. 2 429 HS IN <input type="radio"/> A <input type="radio"/> B		
9	- DATA LOADER - 429 HS OUT <input type="radio"/> A <input type="radio"/> B		RSVD ADS-B NO. 1 429 HS OUT <input type="radio"/> A <input type="radio"/> B		-- RESERVED FOR 429 BUS OUTPUT -- <input type="radio"/> A <input type="radio"/> B <input type="radio"/> A <input type="radio"/> B				RSVD ADS-B NO. 2 429 HS OUT <input type="radio"/> A <input type="radio"/> B		
10	RESERVED ADS-B PROGRAM INPUT <input type="radio"/> 1 <input type="radio"/> 2 <input type="radio"/> 3			SINGLE MODE S TRANSPONDER† <input type="radio"/>	-- RESERVED FOR PROGRAM INPUT -- <input type="radio"/> <input type="radio"/> <input type="radio"/> <input type="radio"/> <input type="radio"/>					ADS-B SURV <input type="radio"/> PROG IN*†	
11	RESERVED <input type="radio"/> PROG IN	TRAF DISP FLT ID <input type="radio"/> PROG IN*†	MALE VOICE <input type="radio"/> PROG IN*†	FDR AND EXTD MAINT <input type="radio"/> PROG IN	-- RESERVED FOR DATA BUS INPUT -- <input type="radio"/> <input type="radio"/> <input type="radio"/> <input type="radio"/> <input type="radio"/> <input type="radio"/>						
12	RESERVED <input type="radio"/> PROG IN	RAD ALT TYPE SEL 4 <input type="radio"/> PROG IN	RA/TA BLOCK <input type="radio"/> XFER PROG	AIRCRAFT TYPE 1 <input type="radio"/> 0 <input type="radio"/> PROG	FUTURE <input type="radio"/> SPARE	OPTION PARITY <input type="radio"/> PROG IN*	RADIO ALTITUDE TYPE SELECT INPUT <input type="radio"/> 3 <input type="radio"/> 2 <input type="radio"/> 1				
13	RA DISPLAY NO. 1/ REC 429 LS/HS OUT <input type="radio"/> A <input type="radio"/> B	RA DISPLAY NO. 2/ REC 429 LS/HS OUT <input type="radio"/> A <input type="radio"/> B	RA NO. 2 STATUS <input type="radio"/> DISC IN	LANDING GEAR <input type="radio"/> DISC IN	CLIMB INHIB NO. 2 <input type="radio"/> DISC IN	RADIO ALT NO. 1 429 LS IN <input type="radio"/> A <input type="radio"/> B		TCAS SYS VALID <input type="radio"/> DISC OUT			
14	TX COORDINATION NO. 2 429 HS OUT <input type="radio"/> A <input type="radio"/> B	RA NO. 1 STATUS <input type="radio"/> DISC IN	RSVD SEL ALT 701/720 429 LS IN <input type="radio"/> A <input type="radio"/> B	XT COORDINATION NO. 1 429 HS IN <input type="radio"/> A <input type="radio"/> B	XT COORDINATION NO. 2 429 HS IN <input type="radio"/> A <input type="radio"/> B	FUTURE <input type="radio"/> SPARE					
15	RESERVED <input type="radio"/>	RESERVED <input type="radio"/>	RESERVED <input type="radio"/>	RESERVED <input type="radio"/>	RESERVED <input type="radio"/>	RESERVED <input type="radio"/>	RESERVED <input type="radio"/>	TX COORDINATION NO. 1 429 HS OUT <input type="radio"/> A <input type="radio"/> B			

**NOTES:**

1. \* Reserved pin on -XX001 TCAS CU.
2. † Reserved pin on -XX002 TCAS CU.
3. ‡ On -XX004 TCAS CU only.

ID-8005706-001

**Figure 3-7. Contact Arrangement for Right Middle Plug (RMP) Insert**



**SYSTEM DESCRIPTION AND INSTALLATION MANUAL**  
TCAS 3000 Traffic Alert and Collision Avoidance System

RIGHT BOTTOM INSERT (RBP):

	A	B	C	D	E	F	G	H	J	K
1	RESERVED ○	RESERVED ○	RESERVED ○	RESERVED ○	RESERVED ○	RESERVED ○	RESERVED ○	WD 270 BIT 18 ○ DISC OUT	WD 270 BIT 19 ○ DISC OUT	WD 270 BIT 20 ○ DISC OUT
2	FUTURE ○ SPARE	FUTURE ○ SPARE	FUTURE ○ SPARE	FUTURE ○ SPARE	FUTURE ○ SPARE	FUTURE ○ SPARE	FUTURE ○ SPARE	WD 270 BIT 21 ○ DISC OUT	WD 270 BIT 22 ○ DISC OUT	WD 270 BIT 23 ○ DISC OUT
3	RADIO ALTIMETER NO. 2 INPUT ARINC 552/ANALOG ○ +      -      VALID			RADIO ALTIMETER NO. 2 429 LS INPUT ○ A      B		FUTURE ○ SPARE	FUTURE ○ SPARE	WD 270 BIT 24 ○ DISC OUT	WD 270 BIT 25 ○ DISC OUT	WD 270 BIT 26 ○ DISC OUT
4	-- RESERVED FOR DISCRETE INPUTS -- ○ SPARE						RA DISP TST INHIB ○ PROG	WD 270 BIT 27 ○ DISC OUT	WD 270 BIT 28 ○ DISC OUT	WD 270 BIT 29 ○ DISC OUT
5	-- ADVISORY INHIBIT DISCRETE INPUTS -- ○ 1      2      3      4				INCREASE CLIMB INHIBIT DISCRETES INPUTS ○ 1      2      3      4			CLIMB INHIBIT DISCRETE INPUTS ○ 3      4		
6	DATA LDR LINK A ○ DISC IN	DATA LOADER DISCRETE INPUTS ○ 2      3      4			CFDS DATA BUS 429 LS OUTPUT ○ A      B		CFDS DATA BUS 429 LS INPUT ○ A      B		SINGLE MODE S ○ PGM PIN	SINGLE RAD ALT ○ PGM PIN
7	AUDIO LEVEL PROGRAM INPUTS ○ 1      2      3 9dB    6dB    3dB			AUDIO TONE ENABLE ○ PROG*	GND DISP MODE ○ PROG	DISP ALL TRAFFIC ○ PROG	CABLE DELAY PROGRAM PINS ○ SIGN    MSB    LSB			PROGRAM ○ COMMON
8	-- RESERVED FOR PROGRAM PINS -- ○				SELF-TEST INHIBIT ○ PROG	TA/RA DISPLAY SYMBOL MAX PROGRAM ○ 16      8      4      2      1				
9	RESERVED ○	RESERVED ○	RESERVED ○	RESERVED ○	RESERVED ○	RESERVED ○	RESERVED ○	RESERVED ○	RESERVED ○	RESERVED ○
10	RESERVED ○	RESERVED ○	RESERVED ○	RESERVED ○	RESERVED ○	RESERVED ○	RESERVED ○	RESERVED ○	RESERVED ○	RESERVED ○

**NOTES:**

- \* Reserved pin on -XX001 TCAS CU.

ID-8005707-001

**Figure 3-8. Contact Arrangement for Right Bottom Plug (RBP) Insert**



**SYSTEM DESCRIPTION AND INSTALLATION MANUAL**  
TCAS 3000 Traffic Alert and Collision Avoidance System

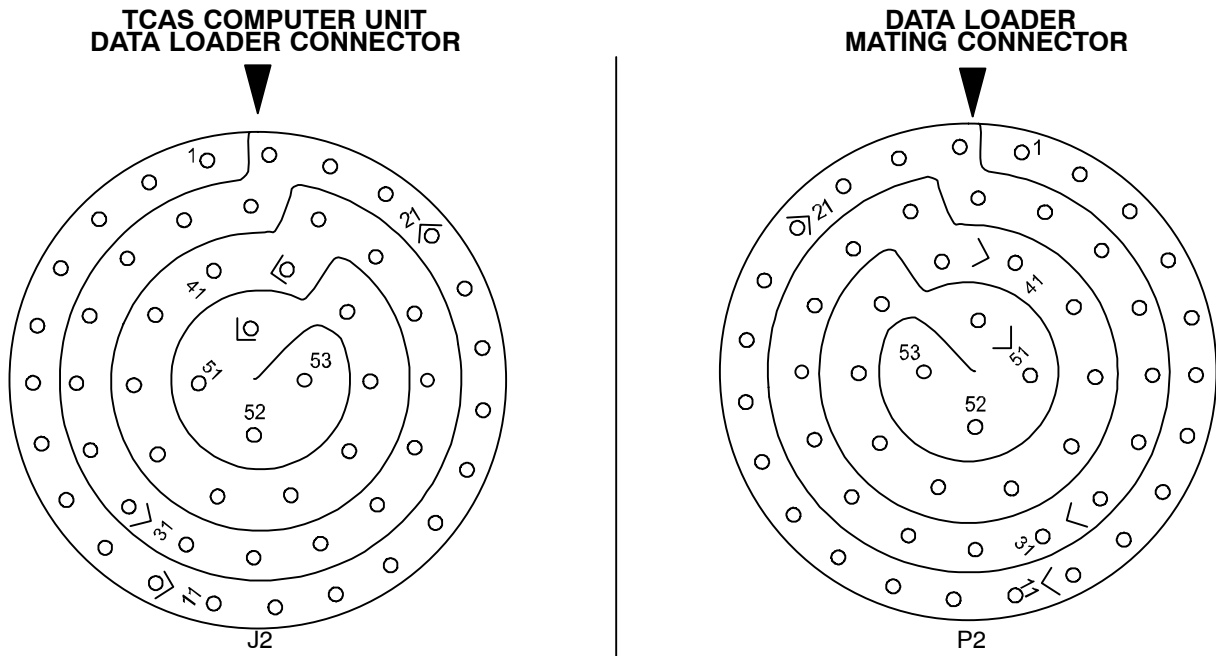

NOTE: VIEWS SHOWN ARE OF MATING SURFACES

AD-53014@

**Figure 3-9. TCAS 3000 Computer Unit Data Loader Connector (J1) Pin Layout**



**SYSTEM DESCRIPTION AND INSTALLATION MANUAL**  
TCAS 3000 Traffic Alert and Collision Avoidance System

**C. Control Panels**

Table 3-1 thru Table 3-3 contain interconnect information for the various control panels. Table 3-1 contains the interconnect data for the ACSS Dual Mode S/TCAS Control Panel, Part No. 4052190-902, -904, -906 and -908. Table 3-2 contains the interconnect data for the ACSS ATCRBS-Mode S/TCAS Control Panel, Part No. 4052190-903, -905, -907 and -909. Table 3-3 contains the interconnect data for the Gables G7130 series control panels.

**Table 3-1. ACSS Dual Mode S Control Panel Interconnect Data**

I/O	Description	Connector Pin	Connects To	Notes
(I)	5 V ac Panel Lighting (C)	J1-1 (20)	----- Acft Lighting Source	
(I)	5 V ac Panel Lighting (H)	J1-2 (20)	----- Acft Lighting Source	
(I)	115 V ac Input Power (H)	J1-3 (20)	----- Acft 115 V ac Supply	
(I)	115 V ac Return (C)	J1-4 (20)	----- Acft ac Ground	
(O)	Antenna Transfer Discrete	J1-5 (22)	----- Antenna Relay	1
(I)	dc Ground	J1-6 (22)	----- Acft dc Ground	
(O)	Standby/On	J1-7 (22)	----- Transponder No.1	
(I)	Chassis Ground	J1-8 (22)	----- Airframe Ground	2
(I)	Functional Test	J1-9 (22)	----- Remote Test Switch	
(O)	Warning & Caution	J1-10 (22)	----- Remote Warn System	
	Spare	J1-11		
(I)	XPDR Fail No.2 Input	J1-12 (22)	----- Transponder No.1	
	Spare	J1-13		
	Spare	J1-14		
	Reserved	J1-15		
(O)	Alt Source Select Discrete	J1-16 (22)	----- Transponder No.1	
	Spare	J1-17		
(I)	Monitor Lamp Pwr	J1-18 (20)	----- 28 V dc, 2A Source	
	Spare	J1-19		
(I)	XPDR Fail No.1 Input	J1-20 (22)	----- See J1-12	4
(I)	Lamp Test	J1-21 (22)	----- Rmt Lamp Test Switch	
(O)	ARINC 429 (A) Out	J1-22 (22)	----- S-- T--S ----- 	3
(O)	ARINC 429 (B) Out	J1-23 (22)	----- S-- T--S -----          GND --        --- GND	3



**SYSTEM DESCRIPTION AND INSTALLATION MANUAL**  
TCAS 3000 Traffic Alert and Collision Avoidance System

**Table 3-1. ACSS Dual Mode S Control Panel Interconnect Data (cont)**

I/O	Description	Connector Pin		Connects To	Notes
	Reserved	J1-24			
	Spare	J2-1			
	Spare	J2-2			
(I)	115 V ac Input Power (H)	J2-3	(20)	----- Acft 115 V ac Supply	
(I)	115 V ac Return (C)	J2-4	(20)	----- Acft ac Ground	
(O)	Antenna Transfer Discrete	J2-5	(22)	----- Antenna Relay	1
(I)	dc Ground	J2-6	(22)	----- Acft dc Ground	
(O)	Standby/On Discrete	J2-7	(22)	----- Transponder No.2	
(I)	Chassis Ground	J2-8	(22)	----- Airframe Ground	2
	Spare	J2-9			
	Spare	J2-10			
	Spare	J2-11			
(I)	XPDR Fail No.2 Input	J2-12	(22)	----- Transponder No.2	
	Spare	J2-13			
	Spare	J2-14			
	Reserved	J2-15			
(O)	Alt Source Select Discrete	J2-16	(22)	----- Transponder No.2	
	Spare	J2-17			
	Spare	J2-18			
	Spare	J2-19			
(I)	XPDR Fail No.1 Input	J2-20	(22)	----- See J2-12	4
	Spare	J2-21			
(O)	ARINC 429 (A) Out	J2-22	(22)	----- S-- T-- S ----- 	3
(O)	ARINC 429 (B) Out	J2-23	(22)	----- S-- T-- S -----          GND --        --- GND	3



**SYSTEM DESCRIPTION AND INSTALLATION MANUAL**  
TCAS 3000 Traffic Alert and Collision Avoidance System

**Table 3-1. ACSS Dual Mode S Control Panel Interconnect Data (cont)**

<b>I/O</b>	<b>Description</b>	<b>Connector Pin</b>	<b>Connects To</b>	<b>Notes</b>
	Reserved	J2-24		
<b>NOTES:</b> <ol style="list-style-type: none"><li>1. Connect either J1-5 or J2-5 to an antenna switching relay if one set of ATC antennas is used in a dual transponder installation.</li><li>2. Tie chassis ground to aircraft frame.</li><li>3. Two wire shielded cable. Tie shields to aircraft dc ground.</li><li>4. Connector pins J1-12 and J1-20 and pins J2-12 and J2-20 are tied together in the controller.</li></ol>				





**SYSTEM DESCRIPTION AND INSTALLATION MANUAL**  
TCAS 3000 Traffic Alert and Collision Avoidance System

**Table 3-2. ACSS ATRBS-Mode S Control Panel Interconnect Data**

I/O	Description	Connector Pin	Connects To	Notes
(I)	5 V ac Pnl Lighting (C)	J1-1 (20)	----- Acft Lighting Source	
(I)	5 V ac Pnl Lighting (H)	J1-2 (20)	----- Acft Lighting Source	
(I)	115 V ac Input Power (H)	J1-3 (20)	----- Acft 115V ac Supply	
(I)	115 V ac Return (C)	J1-4 (20)	----- Acft ac Ground	
(O)	Antenna Transfer Discrete	J1-5 (22)	----- Antenna Relay	1
(I)	dc Ground	J1-6 (22)	----- Acft dc Ground	
(O)	Standby/On	J1-7 (22)	----- Mode S Transponder	
(I)	Chassis Ground	J1-8 (22)	----- Airframe Ground	2
(I)	Functional Test	J1-9 (22)	----- Remote Test Switch	
(O)	Warning & Caution	J1-10 (22)	----- Remote Warn System	
	Spare	J1-11		
(I)	XPDR Fail No.2 Input	J1-12 (22)	----- Mode S Transponder	
	Spare	J1-13		
	Spare	J1-14		
	Reserved	J1-15		
(O)	Alt Source Select Discrete	J1-16 (22)	----- Mode S Transponder	
	Spare	J1-17		
(I)	Monitor Lamp Power	J1-18 (20)	----- 28 V dc, 2A Source	
	Spare	J1-19		
(I)	XPDR Fail No.1 Input	J1-20 (22)	----- See J1-12	4
(I)	Lamp Test	J1-21 (22)	----- Rmt Lamp Test Switch	
(O)	ARINC 429 (A) Out	J1-22 (22)	----- S-- T--S ----- 	3
(O)	ARINC 429 (B) Out	J1-23 (22)	----- S-- T--S -----          GND --        --- GND	3
	Reserved	J1-24		
	Spare	J2-A		
	Spare	J2-B		
	Spare	J2-C		
	Spare	J2-D		



**SYSTEM DESCRIPTION AND INSTALLATION MANUAL**  
TCAS 3000 Traffic Alert and Collision Avoidance System

**Table 3-2. ACSS ATRBS-Mode S Control Panel Interconnect Data (cont)**

I/O	Description	Connector Pin	Connects To	Notes
	Spare	J2-E		
	Spare	J2-F		
	Spare	J2-G		
	Spare	J2-H		
	Spare	J2-J		
	Spare	J2-K		
(O)	Alt No. 1	J2-L (22)	----- Altitude Digitizer No. 1	
	Spare	J2-M		
(O)	Alt No. 2	J2-N (22)	----- Altitude Digitizer No. 2	
	Spare	J2-P		
(O)	Altitude Common	J2-R (22)	----- ATRBS Transponder	
	Spare	J2-S		
(O)	Transponder No. 2 On	J2-T (22)	----- ATRBS Transponder	
	Spare	J2-U		
	Spare	J2-V		
	Spare	J2-W		
(O)	Mode A Reply Pulse (A1)	J2-X (22)	----- ATRBS Transponder	
(O)	Mode A Reply Pulse (A2)	J2-Y (22)	----- ATRBS Transponder	
(O)	Mode A Reply Pulse (A4)	J2-Z (22)	----- ATRBS Transponder	
(O)	Mode A Reply Pulse (B1)	J2-a (22)	----- ATRBS Transponder	
(O)	Mode A Reply Pulse (B2)	J2-b (22)	----- ATRBS Transponder	
(O)	Mode A Reply Pulse (B4)	J2-c (22)	----- ATRBS Transponder	
(O)	Mode A Reply Pulse (C1)	J2-d (22)	----- ATRBS Transponder	
(O)	Mode A Reply Pulse (C2)	J2-e (22)	----- ATRBS Transponder	
(O)	Mode A Reply Pulse (C4)	J2-f (22)	----- ATRBS Transponder	
(O)	Mode A Reply Pulse (D1)	J2-g (22)	----- ATRBS Transponder	
(O)	Mode A Reply Pulse (D2)	J2-h (22)	----- ATRBS Transponder	
(O)	Mode A Reply Pulse (D4)	J2-i (22)	----- ATRBS Transponder	
(O)	Ident Output	J2-j (22)	----- ATRBS Transponder	
	Spare	J2-k		
(I)	ATC Fail	J2-m (22)	----- ATRBS Transponder	



**SYSTEM DESCRIPTION AND INSTALLATION MANUAL**  
 TCAS 3000 Traffic Alert and Collision Avoidance System

**Table 3-2. ACSS ATRBS-Mode S Control Panel Interconnect Data (cont)**

<b>I/O</b>	<b>Description</b>	<b>Connector Pin</b>	<b>Connects To</b>	<b>Notes</b>
(I)	dc Ground	J2-n (22)	----- Acft dc Ground	
	Spare	J2-p		
	Spare	J2-q		
(O)	Alt Rptg On	J2-r (22)	----- ATRBS Transponder	
(O)	Test Output	J2-s (22)	----- ATRBS Transponder	
(O)	Transponder No. 1 On	J2-t	----- NC	
<b>NOTES:</b>				
<ol style="list-style-type: none"> <li>1. Connect to antenna coax switching relay if one set of ATC antennas is used in a dual transponder installation.</li> <li>2. Tie chassis ground to aircraft frame.</li> <li>3. Two wire shielded cable. Tie shields to aircraft dc ground.</li> <li>4. Connector pins J1-12 and J1-20 are tied together in the Control Panel.</li> </ol>				



**SYSTEM DESCRIPTION AND INSTALLATION MANUAL**  
TCAS 3000 Traffic Alert and Collision Avoidance System

**Table 3-3. Gables G7130-XX ATC/TCAS Control Panel Interconnect Data**

I/O	Description	Connector Pin	Connects To	Notes
(I)	5 V ac Pnl Lighting (H)	J1-1 (20)	----- Acft Lighting Source	
(I)	5 V ac Pnl Lighting (L)	J1-2 (20)	----- Acft Lighting Source	
(I)	+28 V dc Input Power (H)	J1-3 (20)	----- Acft 28 V dc Power	
(I)	+28 V dc Return (L)	J1-4 (20)	----- Acft dc Ground	
(O)	Antenna Transfer Discrete	J1-5 (22)	----- Antenna Relay	1, 2
(I)	dc Ground	J1-6 (22)	----- Acft dc Ground	
(O)	Standby/On Output Disc	J1-7 (22)	----- Transponder No. 1	
(I)	Chassis Ground	J1-8 (22)	----- Airframe Ground	3
(I)	Functional Test	J1-9 (22)	----- Remote Test Switch	
(O)	Warning & Caution	J1-10 (22)	----- Remote Warn Sys	2
	Reserved	J1-11		
(I)	XPDR Fail Logic No.2	J1-12 (22)	----- Transponder No. 1	
(I)	Ident Input	J1-13 (22)	----- Remote IDENT Switch	2
(I)	XPDR Fail (High Level)	J1-14	-----NC	2, 4
(O)	Air/Gnd Switched Discrete	J1-15	-----NC	
(O)	Alt Source Select Discrete	J1-16 (22)	----- Transponder No.1	2
	Reserved	J1-17		
(I)	Monitor Lamp Power	J1-18 (20)	----- Acft 28 V dc Power	
	Reserved	J1-19		
(I)	XPDR Configuration	J1-20	-----NC	2
(I)	Lamp Test	J1-21 (22)	----- Rmt Lamp Test SW	2
(O)	ARINC 429 (A) Out	J1-22 (22)	----- S-- T--S ----- 	5
(O)	ARINC 429 (B) Out	J1-23 (22)	----- S-- T--S ----- GND --        --- GND	5
(I)	Air/Gnd Discrete	J1-24 (22)	----- WOW Switch	2
	Reserved	J2-1		
	Reserved	J2-2		
(I)	+28V dc Input Power (H)	J2-3 (20)	----- Acft 28 V dc Power	
(I)	+28V dc Return (L)	J2-4 (20)	----- Acft dc Ground	



**SYSTEM DESCRIPTION AND INSTALLATION MANUAL**  
TCAS 3000 Traffic Alert and Collision Avoidance System

**Table 3-3. Gables G7130-XX ATC/TCAS Control Panel Interconnect Data (cont)**

I/O	Description	Connector Pin	Connects To	Notes
(O)	Antenna Transfer Discrete	J2-5 (22)	----- Antenna Relay	1, 2
(I)	dc Ground	J2-6 (22)	----- Acft dc Ground	
(O)	Standby/On Discrete	J2-7 (22)	----- Transponder No.2	
(I)	Chassis Ground	J2-8 (22)	----- Airframe Ground	3
(I)	Functional Test	J2-9 (22)	----- Remote Test SW	
(O)	Warning & Caution	J2-10 (22)	----- Remote Warn Sys	2
	Reserved	J2-11		
(I)	XPDR Fail Logic No.2	J2-12 (22)	----- Transponder No.2	
(I)	Ident Input	J2-13 (22)	----- Remote Ident SW	2
(I)	XPDR Fail (High Level)	J2-14	----- NC	2, 4
(O)	Air/Gnd Switched Discrete	J2-15 (22)	----- NC	
(O)	Alt Source Select Discrete	J2-16 (22)	----- Transponder No.2	2
	Reserved	J2-17		
(I)	Monitor Lamp Pwr	J2-18 (20)	----- Acft 28 V dc Power	2
	Reserved	J2-19		
(I)	XPDR Configuration	J2-20	----- NC Gnd/Open	2
(I)	Lamp Test	J2-21 (22)	----- Rmt Lamp Test SW	2
(O)	ARINC 429 (A) Out	J2-22 (22)	----- S-- T--S ----- 	5
(O)	ARINC 429 (B) Out	J2-23 (22)	----- S-- T--S ----- GND --            --- GND	5
(I)	Air/Gnd Discrete	J2-24 (22)	----- Acft WOW Switch	2

**NOTES:**

1. Connect either J1-5 or J2-5 to an antenna switching relay if one set of ATC antennas is used in a dual transponder installation.
2. Refer to Loading Gradient Specifications in Table 4-4.
3. Tie chassis ground to aircraft frame.
4. 28 V dc discrete input from Collins TDR-94D transponder.
5. Two wire shielded cable. Tie shields to aircraft dc ground.



**SYSTEM DESCRIPTION AND INSTALLATION MANUAL**  
TCAS 3000 Traffic Alert and Collision Avoidance System

**D. VSI/TRA Displays**

Table 3-4 and Table 3-5 contain the interface information for the various ACSS VSI/TRA displays. Table 3-4 contains interconnect data for the 41-pin connector units. Table 3-5 contains the interconnect data for the 55-pin connector (bootstrap) units.

Figure 3-10 and Figure 3-11 show the connector pin layouts for the VSI/TRA. Figure 3-10 shows the 41-pin connector configuration and Figure 3-11 shows the 55-pin connector configuration.

**Table 3-4. 41-Pin VSI/TRA Interconnect Data**

I/O	Description	Connector Pin	Connects To	Notes
(I)	VS +dc Ref	J1-1 (22)	----- ARINC 575 ADC	
(I)	VS dc Rate	J1-2 (22)	----- ARINC 575 ADC	
(I)	VS -dc Ref	J1-3 (22)	----- ARINC 575 ADC	
(I)	Primary VS (HI)	J1-4 (22)	----- S-- T--S -----              	ARINC 565 ADC or IRS 1
(I)	Primary VS (LO)	J1-6 (22)	----- S-- T--S ----- GND --            ... GND	ARINC 565 ADC or IRS 1
(I)	VS 26 V ac Ref (HI)	J1-5 (22)	----- ARINC 565 ADC or IRS	
(I)	Reserved ARINC Bus (A)	J1-7		
(I)	Reserved ARINC Bus (B)	J1-21		
(I)	VS VALID NO.1	J1-8 (22)	----- ARINC 565/575 ADC or IRS	
(I)	5 V Lamp Dimming (LO)	J1-9 (22)	----- Acft Lamp Dim Ckt	
(I)	5 V Lamp Dimming (HI)	J1-10 (22)	----- Acft Lamp Dim Ckt	
(I)	TCAS TA/RA ARINC 429 (B)	J1-11 (22)	----- S-- T--S ----- 	TCAS Computer 1
(I)	TCAS TA/RA ARINC 429 (A)	J1-26 (22)	----- S-- T--S ----- GND --            ... GND	TCAS Computer 1
(I)	VS No.1 ARINC 429 (B)	J1-12 (22)	----- S-- T--S ----- 	Digital ADC No.1 or PTM No.1 1
(I)	VS No.1 ARINC 429 (A)	J1-27 (22)	----- S-- T--S ----- GND --            ... GND	Digital ADC No.1 or PTM No.1 1
	Spare	J1-13		



**SYSTEM DESCRIPTION AND INSTALLATION MANUAL**  
TCAS 3000 Traffic Alert and Collision Avoidance System

**Table 3-4. 41-Pin VSI/TRA Interconnect Data (cont)**

I/O	Description	Connector Pin		Connects To	Notes
(I)	VS No.2 ARINC 429 (B)	J1-14 (22)	----- S-- T-- S ----- 	Digital ADC No.2 or PTM No.2	
(I)	VS No.2 ARINC 429 (A)	J1-30 (22)	----- S-- T-- S ----- GND --            ... GND	Digital ADC No.2 or PTM No.2	
(I)	Config Strap Common	J1-15 (22)	-----	Config Strap Logic Gnd	5
(I)	VS 26 V ac Ref (C)	J1-16 (22)	-----	ARINC 565 ADC or IRS	
(I)	Config Strap No.3 (CS3)	J1-17 (22)	-----	Gnd/Open	
(O)	PTM Common	J1-18 (20)	----- S-- T-- S ----- 	Pressure Xdcr Mdl	2
(O)	PTM Pwr Out (-15 V dc)	J1-19 (20)	----- S-- T-- S ----- 	Pressure Xdcr Mdl	2
(O)	PTM Pwr Out (+15 V dc)	J1-20 (20)	----- S-- T-- S ----- GND --            ... GND	Pressure Xdcr Mdl	2
(I)	Chassis Ground	J1-22 (22)	-----	Airframe Ground	3
(I)	115 V ac Return (C)	J1-23 (20)	-----	Acft ac Ground	
(I)	Remote Light Sensor (LO)	J1-24 (22)	----- S-- T-- S ----- 	Acft Rmt Light Sensor	1
(I)	Remote Light Sensor (HI)	J1-25 (22)	----- S-- T-- S ----- GND --            ... GND	Acft Rmt Light Sensor	1
	Spare	J1-28			
(O)	RA Valid Out	J1-29 (22)	-----	TCAS Computer	
(I)	Source Sel Discrete In	J1-31 (22)	-----	Gnd/Open	
(I)	Config Strap No.0 (CS0)	J1-32 (22)	-----	Gnd/Open	
(I)	Config Strap No.1 (CS1)	J1-33 (22)	-----	Gnd/Open	
(I)	Config Strap No.2 (CS2)	J1-34 (22)	-----	Gnd/Open	
(I)	Config Strap No.4 (CS4)	J1-35 (22)	-----	Gnd/Open	
(I)	Config Strap No.5 (CS5)	J1-36 (22)	-----	Gnd/Open	
(I)	Config Strap No.6 (CS6)	J1-37 (22)	-----	Gnd/Open	
(I)	Config Strap No.7 (CS7)	J1-38 (22)	-----	Gnd/Open	



**SYSTEM DESCRIPTION AND INSTALLATION MANUAL**  
TCAS 3000 Traffic Alert and Collision Avoidance System

**Table 3-4. 41-Pin VSI/TRA Interconnect Data (cont)**

<b>I/O</b>	<b>Description</b>	<b>Connector Pin</b>	<b>Connects To</b>	<b>Notes</b>
(I)	dc Ground	J1-39 (22)	----- Acft dc Ground	
(I)	115 V ac Input Power (H)	J1-40 (20)	----- Acft 115 V ac Supply	
(I)	Config Strap No.8 (CS8)	J1-41 (22)	----- Gnd/Open	

**NOTES:**

1. Two wire shielded cable. Tie shields to aircraft dc ground.
2. Three wire shielded cable. Tie shields to aircraft dc ground.
3. Tie chassis ground to aircraft frame.





**SYSTEM DESCRIPTION AND INSTALLATION MANUAL**  
TCAS 3000 Traffic Alert and Collision Avoidance System

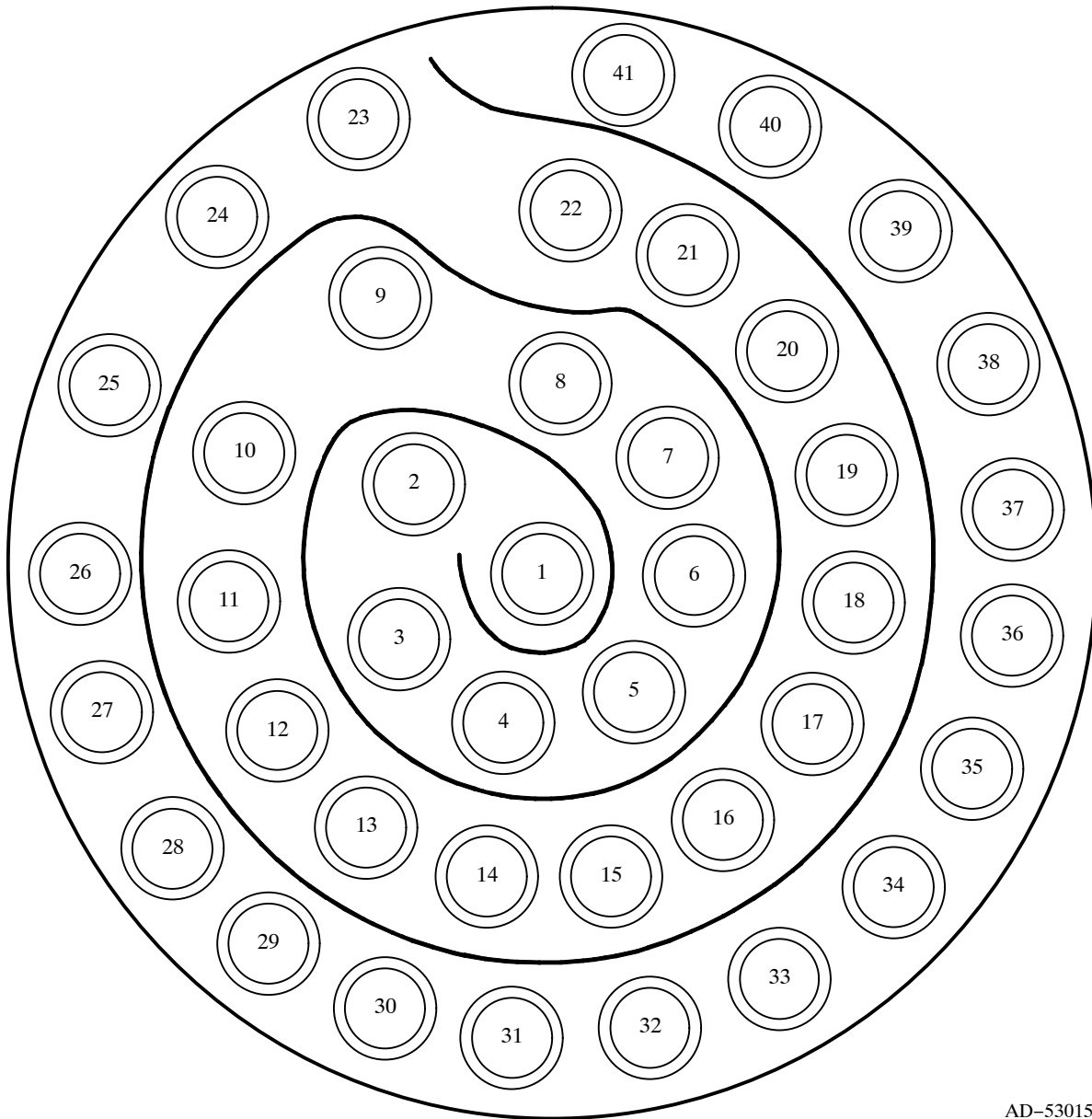

AD-53015@

**Figure 3-10. VSI/TRA 41-Pin Connector Layout**



**SYSTEM DESCRIPTION AND INSTALLATION MANUAL**  
TCAS 3000 Traffic Alert and Collision Avoidance System

**Table 3-5. 55-Pin VSI/TRA Interconnect Data**

I/O	Description	Connector Pin	Connects To	Notes
(I)	Secondary ARINC 565 VS (LO) Input	J1-1 (22)	----- S-- T-- S ----- 	Cross-Side VSI/TRA 1
(I)	Secondary ARINC 565 VS (HI) Input	J1-6 (22)	----- S-- T-- S ----- GND --            --- GND	Cross-Side VSI/TRA 1
(I)	VS dc Rate	J1-2 (22)	-----	ARINC 575 ADC
(I)	VS -dc Ref	J1-3 (22)	-----	ARINC 575 ADC
(O)	Bootstrap Ref Output	J1-4 (22)	-----	Cross-Side VSI/TRA
(I)	VS No.2 Valid Discrete In	J1-5 (22)	-----	Cross-Side VSI/TRA
(I)	Second 26 V ac Ref In	J1-7 (22)	-----	Cross-Side VSI/TRA
(I)	VS +dc Ref	J1-8 (22)	-----	ARINC 575 ADC
(I)	Primary 26 V ac Ref (H)	J1-9 (22)	-----	ARINC 565 ADC
(I)	Primary VS (LO)	J1-10 (22)	----- S-- T-- S ----- 	ARINC 565 ADC 1
(I)	Primary VS (HI)	J1-11 (22)	----- S-- T-- S ----- GND --            --- GND	ARINC 565 ADC 1
(I)	VS No.1 Valid Discrete In	J1-12 (22)	-----	ARINC 565/575 ADC
(O)	R/C Bootstrap (LO) Output	J1-13 (22)	----- S-- T-- S ----- 	Cross-Side VSI/TRA 1
(O)	R/C Bootstrap (HI) Output	J1-14 (22)	----- S-- T-- S ----- GND --            --- GND	Cross-Side VSI/TRA 1
(O)	Bootstrap Command Out	J1-15	-----NC	
	Spare	J1-16		
(I)	Config Strap No.5 (CS5)	J1-17 (22)	-----	Gnd/Open
(I)	Config Strap No.6 (CS6)	J1-18 (22)	-----	Gnd/Open
(I)	Config Strap No.7 (CS7)	J1-19 (22)	-----	Gnd/Open
(I)	Chassis Ground	J1-20 (22)	-----	Airframe Ground 2
(I)	dc Ground	J1-21 (22)	-----	Acft dc Ground
(I)	Config Strap No.8 (CS8)	J1-22 (22)	-----	Gnd/Open
(I)	Remote Light Sensor (HI)	J1-23 (22)	----- S-- T-- S ----- 	Acft Rmt Light Sensor 2
(I)	Remote Light Sensor (LO)	J1-24 (22)	----- S-- T-- S ----- GND --            --- GND	Acft Rmt Light Sensor 2



**SYSTEM DESCRIPTION AND INSTALLATION MANUAL**  
TCAS 3000 Traffic Alert and Collision Avoidance System

**Table 3-5. 55-Pin VSI/TRA Interconnect Data (cont)**

I/O	Description	Connector Pin		Connects To	Notes
(I)	TCAS ARINC 429 (A)	J1-25 (22)	----- S-- T-- S ----- 	TCAS Computer	2
(I)	TCAS ARINC 429 (B)	J1-44 (22)	----- S-- T-- S ----- GND --            --- GND	TCAS Computer	2
(I)	VS No.2 ARINC 429 (A)	J1-26 (22)	----- S-- T-- S ----- 	Digital ADC No.2 or PMT No.2	2
(I)	VS No.2 ARINC 429 (B)	J1-45 (22)	----- S-- T-- S ----- GND --            --- GND	Digital ADC No.2 or PMT No.2	2
(I)	IRS ARINC 429 (A)	J1-27 (22)	----- S-- T-- S ----- 	Inertial Reference Sys	2
(I)	IRS ARINC 429 (B)	J1-46 (22)	----- S-- T-- S ----- GND --            --- GND	Inertial Reference Sys	2
(O)	RA Valid Discrete Out	J1-28 (22)	-----	TCAS Computer	
(I)	Source Select No.2	J1-29 (22)	-----	Gnd/Open	
	Spare	J1-30			
(I)	Source Select No.1	J1-31 (22)	-----	Gnd/Open	
(I)	Config Strap No.0 (CS0)	J1-32 (22)	-----	Gnd/Open	
(I)	Config Strap No.1 (CS1)	J1-33 (22)	-----	Gnd/Open	
(I)	Config Strap No.2 (CS2)	J1-34 (22)	-----	Gnd/Open	
(I)	Config Strap No.3 (CS3)	J1-35 (22)	-----	Gnd/Open	
(I)	Config Strap No.4 (CS4)	J1-36 (22)	-----	Gnd/Open	
(I)	Config Strap Common	J1-37 (22)	-----	Config Strap Logic Gnd	
(I)	115 V ac Return (C)	J1-38 (20)	-----	Acft ac Ground	
	Spare	J1-39			
(I)	115 V ac Input Power (H)	J1-40 (20)	-----	Acft 115 V ac Supply	
	Spare	J1-41			
(I)	5 V Lamp Dimming (HI)	J1-42 (22)	-----	Acft Lamp Dim Ckt	
(I)	5 V Lamp Dimming (LO)	J1-43 (22)	-----	Acft Lamp Dim Ckt	
(I)	VS No.1 ARINC 429 (A)	J1-47 (22)	----- S-- T-- S ----- 	Digital ADC No.1 or PTM No.1	2



**SYSTEM DESCRIPTION AND INSTALLATION MANUAL**  
TCAS 3000 Traffic Alert and Collision Avoidance System

**Table 3-5. 55-Pin VSI/TRA Interconnect Data (cont)**

I/O	Description	Connector Pin		Connects To	Notes
(I)	VS No.1 ARINC 429 (B)	J1-48 (22)	----- S-- T-- S ----- GND --              ...GND	Digital ADC No.1 or PTM No.1	2
(O)	VSI Valid Output Discrete	J1-49 (22)	-----	Cross-Side VSI/TRA	
(O)	PTM Pwr Out (-15 V dc)	J1-50 (20)	----- S-- T-- S ----- 	Pressure Xdcr Mdl	3
(O)	PTM Common	J1-51 (20)	----- S-- T-- S ----- 	Pressure Xdcr Mdl	3
(O)	PTM Pwr Out (+15 V dc)	J1-52 (20)	----- S-- T-- S ----- GND --              ...GND	Pressure Xdcr Mdl	3
	Spare	J1-53			
	Spare	J1-54			
	Spare	J1-55			
<b>NOTES:</b>					
1. Two wire shielded cable. Tie shields to aircraft dc ground.					
2. Tie chassis ground to aircraft frame.					
3. Three wire shielded cable. Tie shields to aircraft dc ground.					



**SYSTEM DESCRIPTION AND INSTALLATION MANUAL**  
TCAS 3000 Traffic Alert and Collision Avoidance System

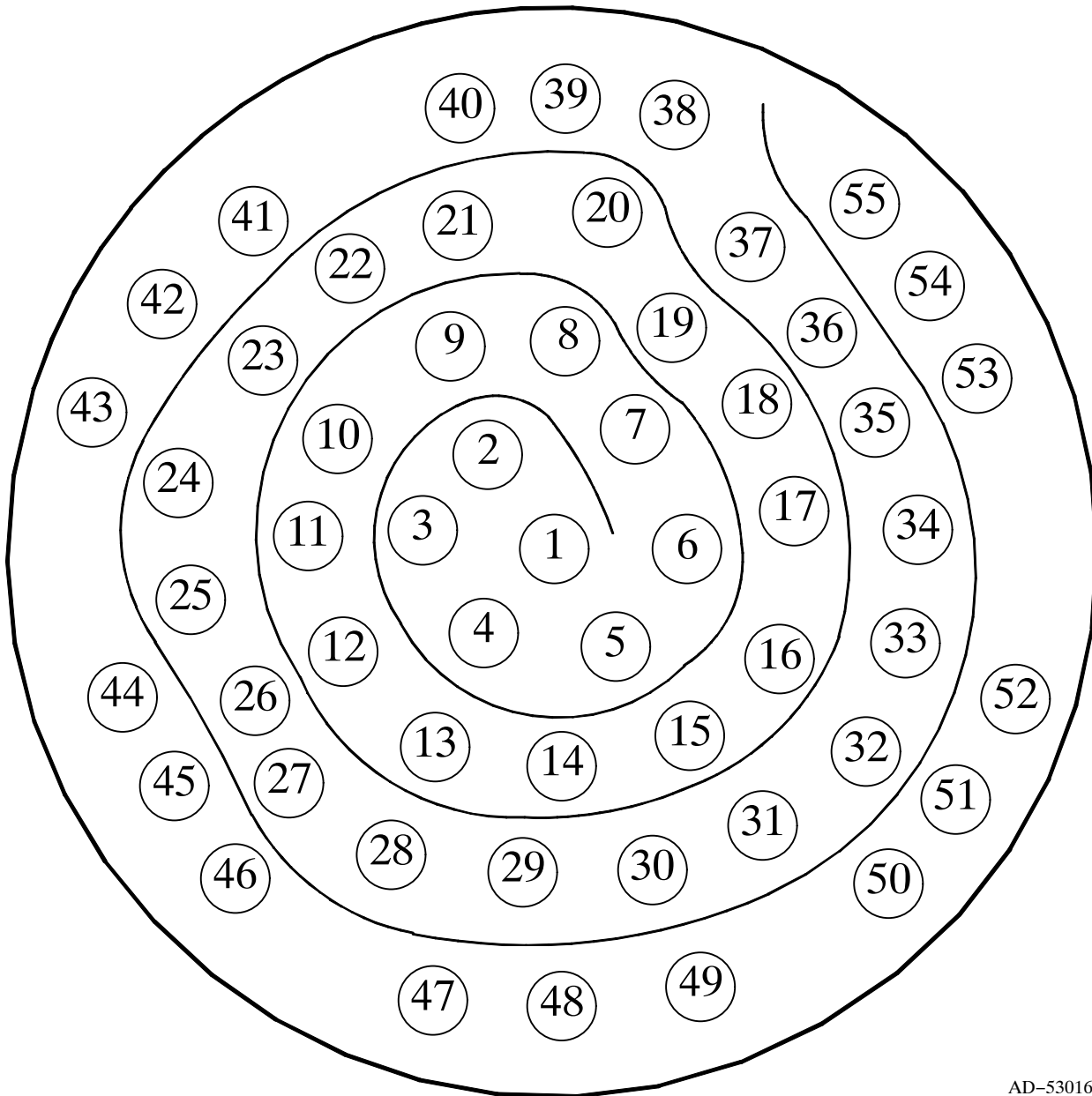

AD-53016@

**Figure 3-11. VSI/TRA 55-Pin Connector Layout**



**SYSTEM DESCRIPTION AND INSTALLATION MANUAL**  
TCAS 3000 Traffic Alert and Collision Avoidance System

**E. Pressure Transducer Module**

Table 3-6 contains the interconnect data for the ACSS Pressure Transducer Module (PTM).

**Table 3-6. Pressure Transducer Module Interconnect Data**

I/O	Description	Connector Pin	Connects To	Notes
(I)	Chassis Ground	J1-1 (22)	----- Airframe	1
(I)	External Reset	J1-2	-----NC	
(O)	Fault Discrete	J1-3	-----NC	
	Reserved, Test Point	J1-4		
(I)	+15 V dc Input Power	J1-5 (22)	----- S-- T--S ----- VSI/TRA	2
(I)	Power Ground	J1-8 (22)	----- S-- T--S ----- VSI/TRA	2
(I)	-15 V dc Input Power	J1-11 (22)	----- S-- T--S ----- VSI/TRA	2
			GND --   ... GND	
	Reserved, Test Point	J1-6		
(O)	ARINC 429 (A) Xmit	J1-7 (22)	----- S-- T--S ----- VSI/TRA	3
(O)	ARINC 429 (B) Xmit	J1-13 (22)	----- S-- T--S ----- VSI/TRA	3
			GND --   ... GND	
	Reserved, Test Point	J1-9		
	Reserved, Test Point	J1-10		
	Reserved, Test Point	J1-12		
	Reserved, Test Point	J1-14		
	Spare	J1-15		
<b>NOTES:</b>				
1. Tie chassis ground (J1-1) to aircraft frame.				
2. Three wire shielded cable. Tie shields to aircraft dc ground.				
3. Two wire shielded cable. Tie shields to aircraft dc ground.				



**SYSTEM DESCRIPTION AND INSTALLATION MANUAL**  
TCAS 3000 Traffic Alert and Collision Avoidance System

**F. Transponders**

Table 3-7 thru Table 3-10 contain the interface information for the ACSS transponders.

The transponders use altimetry data supplied in one of the following formats: ARINC 429 (from a digital ADC), ARINC 575, Synchro, or Gillham code. Altimetry data from one of these source types must be connected to the transponder. If a single altimetry source is used, it should be wired to both sets of transponder inputs.

All Mode S transponders require a unique 24-bit code (Mode S address) assigned to each aircraft. For aircraft registered in the United States, it is necessary to have a specific address code assigned. These address codes are presently issued by:

Federal Aviation Administration  
FAA Aircraft Registry  
P.O. Box 25504  
Oklahoma City, OK 73125

Tel: (405) 954-3116  
Fax: (405) 954-3548

If the aircraft is registered in a country other than the United States, contact the aviation authority of the country in which the aircraft is registered.

The Mode S address is usually issued as an 8-digit octal number. To strap the address code correctly, each digit must be converted to a corresponding binary number. (For example: 7 octal = 111 binary, 1 octal = 001 binary.)

Once the 8-digit octal code is converted to a 24-bit binary number, the straps (address pins) must be grounded or left open according to this binary number representation. Each binary 0 represents an open strap and each binary 1 represents a grounded strap. An example of an octal code number being converted to a binary number is shown below:

Octal address code = 1 2 3 4 5 6 7 0

In binary this number is: (MSB) 001 010 011 100 101 110 111 000 (LSB)

(1) XS-950 Data Link Transponder

Table 3-7 contains the interconnect data for the XS-950 Data Link Transponder, Part No. 7517800-XXYYY.

If additional XS-950 Data Link Transponder installation or operational information is required, refer to Mode S Data Link Transponder System Description and Installation Manual, ACSS Pub. No. A09-3839-001.



**SYSTEM DESCRIPTION AND INSTALLATION MANUAL**  
TCAS 3000 Traffic Alert and Collision Avoidance System

**Table 3-7. XS-950 Data Link Transponder Interconnect Data**

I/O	Description	Connector Pin	Connects To	Notes
(I)	Mode C Pulse A1 #2	P1A-1A (22)	----- Encoding Altm #2	
(I)	Mode C Pulse A2 #2	P1A-1B (22)	----- Encoding Altm #2	
(I)	Mode C Pulse A4 #2	P1A-1C (22)	----- Encoding Altm #2	
(I)	Mode C Pulse B1 #2	P1A-1D (22)	----- Encoding Altm #2	
(I)	Mode C Pulse B2 #2	P1A-1E (22)	----- Encoding Altm #2	
(I)	Mode C Pulse B4 #2	P1A-1F (22)	----- Encoding Altm #2	
(I)	Mode C Pulse C1 #2	P1A-1G (22)	----- Encoding Altm #2	
(I)	Mode C Pulse C2 #2	P1A-1H (22)	----- Encoding Altm #2	
(I)	Mode C Pulse C4 #2	P1A-1J (22)	----- Encoding Altm #2	
(I)	Mode C Pulse D2 #2	P1A-1K (22)	----- Encoding Altm #2	
(I)	ARINC 429 (A) COMM A/B Input from ADLP or ARINC 429(A) FMC/GNSS input	P1A-2A (22)	----- S-- T-- S----- 	Airborne Data Link Processor or FMC/GNSS 1
(I)	ARINC 429 (B) COMM A/B Input from ADLP or ARINC 429(A) FMC/GNSS input	P1A-2B (22)	----- S-- T-- S----- GND--            ---GND	Airborne Data Link Processor or FMC/GNSS 1
(I)	ARINC 429 (A) COMM C/D Input from ADLP or ARINC 429(A) IRS/FMS/Data Concentrator	P1A-2C (22)	----- S-- T-- S----- 	Airborne Data Link Processor or IRS/FMS/Data Concentrator 1
(I)	ARINC 429 (B) Comm C/D Input from ADLP or ARINC 429(A) IRS/FMS/Data Concentrator	P1A-2D (22)	----- S-- T-- S----- GND--            ---GND	Airborne Data Link Processor or IRS/FMS/Data Concentrator 1
(O)	ARINC 429 (A) COMM C/D Output to ADLP or ARINC 429(A) General output Bus	P1A-2E (22)	----- S-- T-- S----- 	Airborne Data Link Processor 1
(O)	ARINC 429 (B) COMM C/D Output to ADLP or ARINC 429(A) General output Bus	P1A-2F (22)	----- S-- T-- S----- GND--            ---GND	Airborne Data Link Processor 1
	Reserved	P1A-2G		
	Reserved	P1A-2H		





**SYSTEM DESCRIPTION AND INSTALLATION MANUAL**  
TCAS 3000 Traffic Alert and Collision Avoidance System

**Table 3-7. XS-950 Data Link Transponder Interconnect Data (cont)**

I/O	Description	Connector Pin		Connects To	Notes
	Reserved	P1A-2J			
(I)	Mode C Pulse D4 #2	P1A-2K	(22) -----	Encoding Altm #2	
	Reserved	P1A-3A			
(O)	XPDR Fail Discrete Out #2	P1A-3B	(22) -----	Control Panel	
(I)	Cable Delay Prog Top/Bot	P1A-3C	(22) -----	Gnd/Open	
(I)	Cable Delay Program B	P1A-3D	(22) -----	Gnd/Open	
(I)	Cable Delay Program A	P1A-3E	(22) -----	Gnd/Open	
(I)	Cable Delay Prog Common	P1A-3F	(22) -----	Program Logic Gnd	
(I)	SDI Program A	P1A-3G	(22) -----	Gnd/Open	
(I)	SDI Program B	P1A-3H	(22) -----	Gnd/Open	
(I)	SDI Common	P1A-3J	(22) -----	Program Logic Gnd	
(I)	Mode C Pulse Common #2	P1A-3K	(22) -----	Encoding Altm #2	
(I)	Syn Alt In #1: Coarse X	P1A-4A	(22) -----	ARINC 565 ADC #1	
(I)	Syn Alt In #1: Coarse Y	P1A-4B	(22) -----	ARINC 565 ADC #1	
(I)	Syn Alt In #1: Coarse Z	P1A-4C	(22) -----	ARINC 565 ADC #1	
(I)	Syn Alt In #1: 26 V Ref (H)	P1A-4D	(22) -----	ARINC 565 ADC #1	
(I)	Syn Alt In #1: 26 V Ref (C)	P1A-4E	(22) -----	ARINC 565 ADC #1	
(I)	Syn Alt In #1: Fine X	P1A-4F	(22) -----	ARINC 565 ADC #1	
(I)	Syn Alt In #1: Fine Y	P1A-4G	(22) -----	ARINC 565 ADC #1	
(I)	Syn Alt In #1: Fine Z	P1A-4H	(22) -----	ARINC 565 ADC #1	
(I)	Syn Alt In #1: Flag	P1A-4J	(22) -----	ARINC 565 ADC #1	
	Reserved	P1A-4K	(22)		
(I)	Max True Airspeed Prog A	P1A-5A	(22) -----	Gnd/Open	
(I)	Max True Airspeed Prog B	P1A-5B	(22) -----	Gnd/Open	
(I)	Max True Airspeed Prog C	P1A-5C	(22) -----	Gnd/Open	
(I)	Max True AS Common	P1A-5D	(22) -----	Program Logic Gnd	
(I)	ARINC 429 (A) TX Coord	P1A-5E	(22) ----- S-- T-- S -----	TCAS Computer	1
(I)	ARINC 429 (B) TX Coord	P1A-5F	(22) ----- S-- T-- S -----	TCAS Computer	1
			GND --     --- GND		



**SYSTEM DESCRIPTION AND INSTALLATION MANUAL**  
TCAS 3000 Traffic Alert and Collision Avoidance System

**Table 3-7. XS-950 Data Link Transponder Interconnect Data (cont)**

I/O	Description	Connector Pin		Connects To	Notes
(O)	ARINC 429 (A) XT Coord	P1A-5G (22)	----- S-- T-- S ----- 	TCAS Computer	1
(O)	ARINC 429 (B) XT Coord	P1A-5H (22)	----- S-- T-- S ----- GND --            --- GND	TCAS Computer	1
(I)	Air/Gnd Discrete Input #2	P1A-5J (22)	-----	Control Panel	
(I)	Air/Gnd Discrete Input #1	P1A-5K (22)	-----	Control Panel	
(I)	ARINC 429 (A) FMC #1/General in #2	P1A-6A (22)	----- S-- T-- S ----- 	FMC	1
(I)	ARINC 429 (B) FMC #1/General in #2	P1A-6B (22)	----- S-- T-- S ----- GND --            --- GND	FMC	1
(I)	ARINC 429 (A) ADL Input	P1A-6C (22)	----- S-- T-- S ----- 	ARINC 615 Airborne Data Loader	1
(I)	ARINC 429 (B) ADL Input	P1A-6D (22)	----- S-- T-- S ----- GND --            --- GND	ARINC 615 Airborne Data Loader	1
(O)	ARINC 429 (A) ADL Out	P1A-6E (22)	----- S-- T-- S ----- 	ARINC 615 Airborne Data Loader	1
(O)	ARINC 429 (B) ADL Out	P1A-6F (22)	----- S-- T-- S ----- GND --            --- GND	ARINC 615 Airborne Data Loader	1
(I)	ADL Input Link A	P1A-6G (22)	-----	ARINC 615 Airborne Data Loader	
(I)	ARINC 575 (A) ADC In #1	P1A-6H (22)	----- S-- T-- S ----- 	ARINC 575 ADC #1	1
(I)	ARINC 575 (B) ADC In #1	P1A-6J (22)	----- S-- T-- S ----- GND --            --- GND	ARINC 575 ADC #1	1
(I)	Single/Dual Antenna Prog	P1A-6K (22)	-----	Gnd/Open	
(I)	ARINC 429 (A) Control Data Input Port A	P1A-7A (22)	----- S-- T-- S ----- 	Control Panel	1
(I)	ARINC 429 (B) Control Data Input Port A	P1A-7B (22)	----- S-- T-- S ----- GND --            --- GND	Control Panel	1
	Reserved	P1A-7C			
(I)	Control Data Port Select In	P1A-7D (22)	-----	Gnd/Open	



**SYSTEM DESCRIPTION AND INSTALLATION MANUAL**  
TCAS 3000 Traffic Alert and Collision Avoidance System

**Table 3-7. XS-950 Data Link Transponder Interconnect Data (cont)**

I/O	Description	Connector Pin		Connects To	Notes	
(I)	ARINC 429 (A) Control Data Input Port B	P1A-7E	(22)	----- S-- T-- S ----- 	Control Panel	
(I)	ARINC 429 (B) Control Data Input Port B	P1A-7F	(22)	----- S-- T-- S ----- GND --            ... GND	Control Panel	
(I)	STBY/ON Discrete Input	P1A-7G	(22)	-----	Control Panel	
(I)	ARINC 429 (A) ADC #1 In	P1A-7H	(22)	----- S-- T-- S ----- 	ARINC 706 ADC #1	1
(I)	ARINC 429 (B) ADC #1 In	P1A-7J	(22)	----- S-- T-- S ----- GND --            ... GND	ARINC 706 ADC #1	1
	Reserved	P1A-7K				
(I)	Top Antenna RF Input	P1A-71	coax	-----	Top Antenna	
(I)	Mode S Adrs Bit A1 (MSB)	P1B-1A	(22)	-----	Gnd/Open	
(I)	Mode S Address Bit A2	P1B-1B	(22)	-----	Gnd/Open	
(I)	Mode S Address Bit A3	P1B-1C	(22)	-----	Gnd/Open	
(I)	Mode S Address Bit A4	P1B-1D	(22)	-----	Gnd/Open	
(I)	Mode S Address Bit A5	P1B-1E	(22)	-----	Gnd/Open	
(I)	Mode S Address Bit A6	P1B-1F	(22)	-----	Gnd/Open	
(I)	Mode S Address Bit A7	P1B-1G	(22)	-----	Gnd/Open	
(I)	Mode S Address Bit A8	P1B-1H	(22)	-----	Gnd/Open	
(I)	Mode S Address Bit A9	P1B-1J	(22)	-----	Gnd/Open	
(I)	Mode S Address Bit A10	P1B-1K	(22)	-----	Gnd/Open	
(I)	Mode S Address Bit A11	P1B-2A	(22)	-----	Gnd/Open	
(I)	Mode S Address Bit A12	P1B-2B	(22)	-----	Gnd/Open	
(I)	Mode S Address Bit A13	P1B-2C	(22)	-----	Gnd/Open	
(I)	Mode S Address Bit A14	P1B-2D	(22)	-----	Gnd/Open	
(I)	Mode S Address Bit A15	P1B-2E	(22)	-----	Gnd/Open	
(I)	Mode S Address Bit A16	P1B-2F	(22)	-----	Gnd/Open	
(I)	Mode S Address Bit A17	P1B-2G	(22)	-----	Gnd/Open	
(I)	Mode S Address Bit A18	P1B-2H	(22)	-----	Gnd/Open	
(I)	Mode S Address Bit A19	P1B-2J	(22)	-----	Gnd/Open	



**SYSTEM DESCRIPTION AND INSTALLATION MANUAL**  
TCAS 3000 Traffic Alert and Collision Avoidance System

**Table 3-7. XS-950 Data Link Transponder Interconnect Data (cont)**

I/O	Description	Connector Pin		Connects To	Notes	
(I)	Mode S Address Bit A20	P1B-2K	(22)	-----	Gnd/Open	
(I)	Mode S Address Bit A21	P1B-3A	(22)	-----	Gnd/Open	
(I)	Mode S Address Bit A22	P1B-3B	(22)	-----	Gnd/Open	
(I)	Mode S Address Bit A23	P1B-3C	(22)	-----	Gnd/Open	
(I)	Mode S Adrs Bit A24 (LSB)	P1B-3D	(22)	-----	Gnd/Open	
(I)	Mode S Adrs Bit Common	P1B-3E	(22)	-----	Address Logic Gnd	
	Reserved	P1B-3F				
	Reserved	P1B-3G				
(I)	Functional Test Discrete In	P1B-3H	(22)	-----	Remote Test Switch	
(O)	Alt Comparison Fail Discrete Output	P1B-3J	(22)	-----	Control Panel	
(O)	XPDR Fail Discrete Out #1	P1B-3K	(22)	-----NC	Control Panel	
(I)	Mode C Pulse A1 #1	P1B-4A	(22)	-----	Encoding Altm #1	
(I)	Mode C Pulse A2 #1	P1B-4B	(22)	-----	Encoding Altm #1	
(I)	Mode C Pulse A4 #1	P1B-4C	(22)	-----	Encoding Altm #1	
(I)	Mode C Pulse B1 #1	P1B-4D	(22)	-----	Encoding Altm #1	
(I)	Mode C Pulse B2 #1	P1B-4E	(22)	-----	Encoding Altm #1	
(I)	Mode C Pulse B4 #1	P1B-4F	(22)	-----	Encoding Altm #1	
(I)	Mode C Pulse C1 #1	P1B-4G	(22)	-----	Encoding Altm #1	
(I)	Mode C Pulse C2 #1	P1B-4H	(22)	-----	Encoding Altm #1	
(I)	Mode C Pulse C4 #1	P1B-4J	(22)	-----	Encoding Altm #1	
(I)	Mode C Pulse D2 #1	P1B-4K	(22)	-----	Encoding Altm #1	
(I)	ARINC 429 (A) ADC #2 In	P1B-5A	(22)	----- S-- T-- S ----- 	ARINC 706 ADC #2	1
(I)	ARINC 429 (B) ADC #2 In	P1B-5B	(22)	----- S-- T-- S ----- GND--        ---GND	ARINC 706 ADC #2	1
(I)	ARINC 575 (A) ADC #2 In	P1B-5C	(22)	----- S-- T-- S ----- 	ARINC 575 ADC #2	1
(I)	ARINC 575 (B) ADC #2 In	P1B-5D	(22)	----- S-- T-- S ----- GND--        ---GND	ARINC 575 ADC #2	1
(O)	ARINC 429 (A) Comm A/B Output to ADLP	P1B-5E	(22)	----- S-- T-- S ----- 	Airborne Data Link Processor	1



**SYSTEM DESCRIPTION AND INSTALLATION MANUAL**  
TCAS 3000 Traffic Alert and Collision Avoidance System

**Table 3-7. XS-950 Data Link Transponder Interconnect Data (cont)**

I/O	Description	Connector Pin		Connects To	Notes
(O)	ARINC 429 (B) Comm A/B Output to ADLP	P1B-5F (22)	----- S-- T-- S ----- GND --    ... GND	Airborne Data Link Processor	1
(I)	Extended Squitter disable discrete input	P1B-5G (22)	-----	Gnd/Open	
(I)	Mode S Data Link Program	P1B-5H (22)	-----	Gnd/Open	
(I)	Antenna Bite Program	P1B-5J (22)	-----	Gnd/Open	
(I)	Mode C Pulse D4 #1	P1B-5K (22)	-----	Encoding Altm #1	
(I)	ARINC 429 (A) Maintenance Data Input	P1B-6A (22)	----- S-- T-- S ----- 	Onboard Maint Computer System	1
(I)	ARINC 429 (B) Maintenance Data Input	P1B-6B (22)	----- S-- T-- S ----- GND --    ... GND	Onboard Maint Computer System	1
(O)	ARINC 429 (A) Maintenance Data Output	P1B-6C (22)	----- S-- T-- S ----- 	Onboard Maint Computer System	1
(O)	ARINC 429 (B) Maintenance Data Output	P1B-6D (22)	----- S-- T-- S ----- GND --    ... GND	Onboard Maint Computer System	1
(I)	Air Data Source Select Discrete Input	P1B-6E (22)	-----	Gnd/Open	
(I)	Alt Type Select Prog B	P1B-6F (22)	-----	Gnd/Open	
(I)	Alt Type Select Prog A	P1B-6G (22)	-----	Gnd/Open	
(I)	Alt Type Select Common Reserved	P1B-6H (22) P1B-6J	-----	Program Logic Gnd	
(I)	Mode C Pulse Common #1	P1B-6K (22)	-----	Encoding Altm #1	
(I)	Syn Alt In #2: Coarse X	P1B-7A (22)	-----	ARINC 565 ADC #2	
(I)	Syn Alt In #2: Coarse Y	P1B-7B (22)	-----	ARINC 565 ADC #2	
(I)	Syn Alt In #2: Coarse Z	P1B-7C (22)	-----	ARINC 565 ADC #2	
(I)	Syn Alt In #2: 26 V Ref (H)	P1B-7D (22)	-----	ARINC 565 ADC #2	
(I)	Syn Alt In #2: 26 V Ref (C)	P1B-7E (22)	-----	ARINC 565 ADC #2	
(I)	Syn Alt In #2: Fine X	P1B-7F (22)	-----	ARINC 565 ADC #2	
(I)	Syn Alt In #2: Fine Y	P1B-7G (22)	-----	ARINC 565 ADC #2	
(I)	Syn Alt In #2: Fine Z	P1B-7H (22)	-----	ARINC 565 ADC #2	
(I)	Syn Alt In #2: Flag	P1B-7J (22)	-----	ARINC 565 ADC #2	
	Reserved	P1B-7K			



**SYSTEM DESCRIPTION AND INSTALLATION MANUAL**  
TCAS 3000 Traffic Alert and Collision Avoidance System

**Table 3-7. XS-950 Data Link Transponder Interconnect Data (cont)**

I/O	Description	Connector Pin		Connects To	Notes	
(I)	Bottom Antenna RF Input	P1B-71	coax	Bottom Antenna		
(I)	115 V ac Input Power (H)	P1C-1	(20)	Acft 115 V ac Sup		
	Spare	P1C-2				
(I)	+28 V dc Return (L)	P1C-3	(16)	Acft dc Ground		
(I)	XPDR OFF (NO)	P1C-4		-----NC		
	Spare	P1C-5				
(O)	Fan +28 V dc	P1C-6	(22)	Fan +		
(I)	115 V ac Return (L)	P1C-7	(20)	Acft ac Ground		
(I)	Signal Ground	P1C-8	(16)	Acft ac Ground		
(O)	Fan Return (L)	P1C-9		Fan -		
(I)	+28 V dc Input Power	P1C-10	(16)	+28V Acft Power		
(I)	Chassis Ground	P1C-11	(16)	Airframe Ground	2	
I/O	Suppression Pulse	P1C-12	coax	L-Band Suppression Bus		
I/O	Suppression Pulse	P1C-13	coax	L-Band Suppression Bus		
<p>The interconnect data that follows is for the ARINC 615 Portable Data Loader (PDL) connector J1 located on the front panel of the transponder. The transponder's operational software can be updated (upload to transponder) through this connector. In addition, the contents of the fault log can be extracted for analysis and troubleshooting (download from transponder).</p> <p>The 53 pin front panel PDL connector contains both an ARINC 429 high speed bus interface for connection to an ARINC 615 PDL, and an RS-232 bus interface for connection to a personal computer (PC) through a standard serial port. Only the pins used by the transponder are shown.</p> <p>The PDL standard interface cable should be 10 feet in length (3 meters) and be terminated with a connector type MS27473T-18A-53S at the data loader end and connector type MS27473T-18A-53P at the transponder end.</p>						
(I)	ARINC 429 (A) PDL Input	J1-1	(22)	----- S-- T-- S -----	ARINC 615 PDL	3
(I)	ARINC 429 (B) PDL Input	J1-2	(22)	----- S-- T-- S -----	ARINC 615 PDL	3
(I)	Bus Shield	J1-5	(22)	-----	Chassis Ground	3
(O)	ARINC 429 (A) PDL Out	J1-8	(22)	----- S-- T-- S -----	ARINC 615 PDL	4
(O)	ARINC 429 (B) PDL Out	J1-9	(22)	----- S-- T-- S -----	ARINC 615 PDL	4
(O)	Bus Shield	J1-16	(22)	-----	Chassis Ground	4
	PDL Link A	J1-18	(22)	-----	ARINC 615 PDL	
	PDL Link B	J1-19	(22)	-----	ARINC 615 PDL	



**SYSTEM DESCRIPTION AND INSTALLATION MANUAL**  
TCAS 3000 Traffic Alert and Collision Avoidance System

**Table 3-7. XS-950 Data Link Transponder Interconnect Data (cont)**

<b>I/O</b>	<b>Description</b>	<b>Connector Pin</b>	<b>Connects To</b>	<b>Notes</b>
(O)	115 V ac Power Out (H)	J1-20 (22)	ARINC 615 PDL	5
(O)	Chassis Ground	J1-21 (22)	ARINC 615 PDL	5
(O)	115 V ac Power Out (C)	J1-22 (22)	ARINC 615 PDL	5
(O)	+28 V dc Power Out	J1-37 (22)	ARINC 615 PDL	6
(O)	+28 V dc Return	J1-38 (22)	ARINC 615 PDL	6
(I)	RS-232 PDL Input	J1-40 (22)	RS-232 Interface	7
(O)	RS-232 PDL Output	J1-41 (22)	RS-232 Interface	7
	Logic Common (Gnd)	J1-48 (22)	RS-232 Interface	7
	Logic Common (Gnd)	J1-49 (22)	RS-232 Interface	7
(I)	PDL Function Discrete #1	J1-50 (22)	ARINC 615 PDL	
(I)	PDL Function Discrete #2	J1-51 (22)	ARINC 615 PDL	
(I)	PDL Function Discrete #3	J1-52 (22)	ARINC 615 PDL	
(I)	PDL Function Discrete #4	J1-53 (22)	ARINC 615 PDL	

**NOTES:**

1. Two wire shielded cable. Tie shields to aircraft dc ground.
2. Tie chassis ground to aircraft frame.
3. Two wire shielded cable. Tie shield to pin 5.
4. Two wire shielded cable. Tie shield to pin 16.
5. The 115 V ac (H) and 115 V ac (C) should be shielded or twisted and shielded with an insulating jacket over the shield. The shield should be connected to chassis ground (pin 21).
6. There is a +28 V dc output available from the transponder, however most ARINC 615 Data Loaders do not have the capability to operate from 28 Volt power.
7. If the RS-232 interface is going to be used, these pins should be connected to a standard serial port (usually a 9-pin D connector).



**SYSTEM DESCRIPTION AND INSTALLATION MANUAL**  
TCAS 3000 Traffic Alert and Collision Avoidance System

(2) RCZ-852 Diversity Mode S Transponder

Table 3-8 contains the interconnect data for the RCZ-852 Diversity Mode S Transponder, Part No. 7510700-850/-951.

Prior to final installation of the transponder mounting tray, the strap assembly, Figure 3-12, located on the back of each mounting tray must be programmed to incorporate the aircraft Mode S address and the desired options. Information for programming the strap assembly is contained in Table 3-9 and Table 3-10.

Programming of the strap assembly consists of removing or installing a string of jumper wires that provide a 48-bit serial data word for encoding the system configuration. In Table 3-10, the output is grounded if the corresponding W\* (jumper wire) is installed for a particular bit, and open if the jumper wire is cut out.

The strap assembly is shipped with all 48-bit jumpers installed. If a jumper is inadvertently cut out or a parameter change requires a jumper to be reinstalled, a suitable piece of AWG 24 bus wire should be used.

**Table 3-8. RCZ-852 Diversity Mode S Transponder Interconnect Data**

I/O	Description	Connector Pin	Connects To	Notes
(O)	XPDR +28 V FAN RTN	J1-1	-----NC	
(O)	XPDR +28 V FAN PWR	J1-2	-----NC	
I/O	MUT SUP (P)	J1-3 (24)	----- S----- S ----- GND --    ... GND	L-Band Suppression Bus 1
	Spare	J1-4		
	Spare	J1-5		
	Spare	J1-6		
(I)	XPDR +28V RTN	J1-7 (22)	-----	Acft dc Ground
(I)	XPDR +28V PWR	J1-8 (22)	-----	Acft 28 V Supply
(I)	XPDR +28V PWR	J1-9 (22)	-----	Acft 28 V Supply
	Spare	J1-10		
(I)	PROGRAM ENA (PO)	J1-11	-----NC	
(O)	XPDR TX RS232	J1-12	-----NC	
	Reserved	J1-13		
	Reserved	J1-14		
	Reserved	J1-15		
	Reserved	J1-16		
(I)	dc GROUND	J1-17 (22)	-----	Acft dc Ground
(I)	dc GROUND	J1-18 (22)	-----	Acft dc Ground





**SYSTEM DESCRIPTION AND INSTALLATION MANUAL**  
TCAS 3000 Traffic Alert and Collision Avoidance System

**Table 3-8. RCZ-852 Diversity Mode S Transponder Interconnect Data (cont)**

I/O	Description	Connector Pin		Connects To	Notes
(I)	dc GROUND	J1-19	(22) -----	Acft dc Ground	
(I)	XPDR +28V RTN	J1-20	(22) -----	Acft dc Ground	
(I)	dc GROUND	J1-21	(22) -----	Acft dc Ground	
	Spare	J1-22			
(O)	XPDR VALID (PO)	J1-23	-----NC		
(I)	XPDR RX RS232	J1-24	-----NC		
(O)	PROGRAM +15V	J1-25	-----NC		
(O)	XPDR to TCAS 429 (A)	J1-26	(22) ----- S-- T-- S ----- GND --   --- GND 	TCAS Computer	2
(O)	XPDR to TCAS 429 (B)	J1-27	(22) ----- S-- T-- S ----- GND --   --- GND	TCAS Computer	2
(O)	XPDR to DLP A/B 429 (A)	J1-28	(22) ----- S-- T-- S ----- 	Airborne Data Link Processor	2
(O)	XPDR to DLP A/B 429 (B)	J1-29	(22) ----- S-- T-- S ----- GND --   --- GND	Airborne Data Link Processor	2
(O)	XPDR to DLP C/D 429 (A)	J1-30	(22) ----- S-- T-- S ----- 	Airborne Data Link Processor	2
(O)	XPDR to DLP C/D 429 (B)	J1-31	(22) ----- S-- T-- S ----- GND --   --- GND	Airborne Data Link Processor	2
(I)	ADC1 to XPDR 429/575A	J1-32	(22) ----- S-- T-- S ----- 	ARINC 429 or 575 ADC #1	2
(I)	ADC1 to XPDR 429/575B	J1-33	(22) ----- S-- T-- S ----- GND --   --- GND	ARINC 429 or 575 ADC #1	2
(I)	CTL1 to XPDR 429 (A)	J1-34	(22) ----- S-- T-- S ----- 	Control Panel	2
(I)	CTL1 to XPDR 429 (B)	J1-35	(22) ----- S-- T-- S ----- GND --   --- GND	Control Panel	2
	Reserved	J1-36			
	Reserved	J1-37			
	Reserved	J1-38			
	Reserved	J1-39			



**SYSTEM DESCRIPTION AND INSTALLATION MANUAL**  
TCAS 3000 Traffic Alert and Collision Avoidance System

**Table 3–8. RCZ–852 Diversity Mode S Transponder Interconnect Data (cont)**

I/O	Description	Connector Pin		Connects To	Notes
(I)	TCAS to XPDR 429 (A)	J1–40	(22) ----- S-- T-- S -----	TCAS Computer	2
(I)	TCAS to XPDR 429 (B)	J1–41	(22) ----- S-- T-- S ----- GND --   --- GND	TCAS Computer	2
(I)	DLP A/B to XPDR 429 (A)	J1–42	(22) ----- S-- T-- S -----	Airborne Data Link Processor	2
(I)	DLP A/B to XPDR 429 (B)	J1–43	(22) ----- S-- T-- S ----- GND --   --- GND	Airborne Data Link Processor	2
(I)	DLP C/D to XPDR 429 (A)	J1–44	(22) ----- S-- T-- S -----	Airborne Data Link Processor	2
(I)	DLP C/D to XPDR 429 (B)	J1–45	(22) ----- S-- T-- S ----- GND --   --- GND	Airborne Data Link Processor	2
(I)	ADC2 to XPDR 429/575A	J1–46	(22) ----- S-- T-- S -----	ARINC 429/575 Digital ADC	2
(I)	ADC2 to XPDR 429/575B	J1–47	(22) ----- S-- T-- S ----- GND --   --- GND	ARINC 429/575 Digital ADC	2
(I)	CTL2 to XPDR 429 (A)	J1–48	(22) ----- S-- T-- S -----	Control Panel	2
(I)	CTL2 to XPDR 429 (B)	J1–49	(22) ----- S-- T-- S ----- GND --   --- GND	Control Panel	2
(O)	XPDR to CTL 429 (A)	J1–50	(22) ----- S-- T-- S -----	Control Panel	2, 3
(O)	XPDR to CTL 429 (B)	J1–51	(22) ----- S-- T-- S ----- GND --   --- GND	Control Panel	2, 3
	Reserved	J1–52			
(I)	ENC ALT1 C1 (N)	J1–53	(24) -----	Encoding Altm #1	
(I)	ENC ALT1 C2 (N)	J1–54	(24) -----	Encoding Altm #1	
(I)	ENC ALT1 C4 (N)	J1–55	(24) -----	Encoding Altm #1	
(I)	ENC ALT1 D2 (N)	J1–56	(24) -----	Encoding Altm #1	
(I)	ENC ALT1 D4 (N)	J1–57	(24) -----	Encoding Altm #1	
(I)	ENC ALT1 A1 (N)	J1–58	(24) -----	Encoding Altm #1	
(I)	ALT COMP ENA (NO)	J1–59	(24) -----	Gnd/Open	4
(I)	ALT SRC SEL2 (NO)	J1–60	(24) -----	Gnd/Open	4



**SYSTEM DESCRIPTION AND INSTALLATION MANUAL**  
TCAS 3000 Traffic Alert and Collision Avoidance System

**Table 3–8. RCZ–852 Diversity Mode S Transponder Interconnect Data (cont)**

I/O	Description	Connector Pin		Connects To	Notes	
(I)	CTL SRC SEL1 (NO)	J1–61	(24)	-----	Gnd/Open	4
	Reserved	J1–62				
	Reserved	J1–63				
(I)	FMS to XPDR 429 (A)	J1–64	(22)	----- S-- T-- S -----	Flt Management Sys	2
(I)	FMS to XPDR 429 (B)	J1–65	(22)	----- S-- T-- S -----	Flt Management Sys	2
				GND --   --- GND		
	Reserved	J1–66				
(I)	ENC ALT1 A2 (N)	J1–67	(24)	-----	Encoding Altm #1	
(I)	ENC ALT1 A4 (N)	J1–68	(24)	-----	Encoding Altm #1	
(I)	ENC ALT1 B1 (N)	J1–69	(24)	-----	Encoding Altm #1	
(I)	ENC ALT1 B2 (N)	J1–70	(24)	-----	Encoding Altm #1	
(I)	ENC ALT1 B4 (N)	J1–71	(24)	-----	Encoding Altm #1	
(I)	XPDR STANDBY (NO)	J1–72	(24)	-----	Control Panel	
(I)	SQUAT SWITCH 1 (NO)	J1–73	(24)	-----	Control Panel or Acft Squat Switch	4
(I)	XPDR OFF (NO)	J1–74		-----NC		
(I)	SQUAT SWITCH 2 (NO)	J1–75	(24)	-----	Control Panel or Acft Squat Switch	4
	XPDR TX RCB (P)	J1–76		-----NC		
	XPDR TX RCB (N)	J1–77		-----NC		
	XPDR RX RCB (P)	J1–78		-----NC		
	XPDR RX RCB (N)	J1–79		-----NC		
(I)	ENC ALT2 C1 (N)	J1–80	(24)	-----	Encoding Altm #2	
(I)	ENC ALT2 C2 (N)	J1–81	(24)	-----	Encoding Altm #2	
(I)	ENC ALT2 C4 (N)	J1–82	(24)	-----	Encoding Altm #2	
(I)	ENC ALT2 D2 (N)	J1–83	(24)	-----	Encoding Altm #2	
(I)	ENC ALT2 D4 (N)	J1–84	(24)	-----	Encoding Altm #2	
(I)	ENC ALT2 A1 (N)	J1–85	(24)	-----	Encoding Altm #2	
	Reserved	J1–86				
	Reserved	J1–87				
	Reserved	J1–88				



**SYSTEM DESCRIPTION AND INSTALLATION MANUAL**  
TCAS 3000 Traffic Alert and Collision Avoidance System

**Table 3–8. RCZ–852 Diversity Mode S Transponder Interconnect Data (cont)**

I/O	Description	Connector Pin		Connects To	Notes
	Reserved	J1–89			
(O)	XPDR STRAP +5V	J1–90	(26) -----	Strap Board (Red)	4
(O)	XPDR STRAP CLK (N)	J1–91	(26) -----	Strap Board (Blue)	4
(O)	XPDR STRAP LOAD (N)	J1–92	(26) -----	Strap Board (Orn)	4
(I)	XPDR STRAP DATA (P)	J1–93	(26) -----	Strap Board (Wht)	4
(I)	ENC ALT2 A2 (N)	J1–94	(24) -----	Encoding Altm #2	
(I)	ENC ALT2 A4 (N)	J1–95	(24) -----	Encoding Altm #2	
(I)	ENC ALT2 B1 (N)	J1–96	(24) -----	Encoding Altm #2	
(I)	ENC ALT2 B2 (N)	J1–97	(24) -----	Encoding Altm #2	
(I)	ENC ALT2 B4 (N)	J1–98	(24) -----	Encoding Altm #2	
(O)	XPDR ACTIVE (NO)	J1–99	(24) -----	Antenna Switching Relay	4
(O)	XPDR VALID (NO)	J1–100	(24) -----	Control Panel	
	Reserved	J1–101			
(O)	ALT VALID (NO)	J1–102	(24) -----	Control Panel	5
(O)	XPDR STRAP GND	J1–103	(26) -----	Strap Board (Blk)	4
(O)	XPDR STRAP PGM (N)	J1–104	(26) -----	Strap Board (Grn)	4
(O)	XPDR STRAP PGM (P)	J1–105	(26) -----	Strap Board (Yel)	4
-	POLARIZATION PIN	J1–106	-----NC		
(I)	Bottom Antenna RF Input	J2	coax -----	Bottom Antenna	
(I)	Top Antenna RF Input	J3	coax -----	Top Antenna	
<b>NOTES:</b>					
1. Use AWG–24 single conductor, shielded wire. Attach shield to ground loop E1 or E2 on back of mounding tray.					
2. Two wire shielded cable. Tie shields to ground loop E1 or E2 located on back of mounting tray.					
3. This ARINC 429 output is required on some Collins Control Panels that require a feedback loop to make sure the transponder is working properly.					
4. Refer to interface descriptions in Table 4–9.					
5. This output is connected only if the control panel has an ALT FAIL input function.					



**SYSTEM DESCRIPTION AND INSTALLATION MANUAL**  
TCAS 3000 Traffic Alert and Collision Avoidance System

**Table 3-9. Strap Assembly Strap Assignments**

<b>Strap Number</b>	<b>Name</b>	<b>Strap Number</b>	<b>NAME</b>
W1	System Position B0	W25	Mode S Address B16
W2	System Position B1	W26	Mode S Address B17
W3	Parity	W27	Mode S Address B18
W4	Parity	W28	Mode S Address B19
W5	Squat Switch Polarity	W29	Mode S Address B20
W6	Maximum Airspeed B0	W30	Mode S Address B21
W7	Maximum Airspeed B1	W31	Mode S Address B22
W8	Maximum Airspeed B2	W32	Mode S Address B23
W9	Mode S Address B0	W33	Altitude Source B0
W10	Mode S Address B1	W34	Altitude Source B1
W11	Mode S Address B2	W35	DLP Installed
W12	Mode S Address B3	W36	TCAS II Installed
W13	Mode S Address B4	W37	Antenna Cable Installation B0
W14	Mode S Address B5	W38	Antenna Cable Installation B1
W15	Mode S Address B6	W39	TCAS TA Display Enable
W16	Mode S Address B7	W40	TCAS I Installed
W17	Mode S Address B8	W41	Altitude Resolution
W18	Mode S Address B9	W42	Reserved
W19	Mode S Address B10	W43	Reserved
W20	Mode S Address B11	W44	Reserved
W21	Mode S Address B12	W45	Reserved
W22	Mode S Address B13	W46	Reserved
W23	Mode S Address B14	W47	Reserved
W24	Mode S Address B15	W48	Reserved

**NOTE:** The strap logic levels are as follows:

- GND = Jumper wire installed (Uncut)
- OPEN = Jumper wire not installed (Cut)



**SYSTEM DESCRIPTION AND INSTALLATION MANUAL**  
TCAS 3000 Traffic Alert and Collision Avoidance System

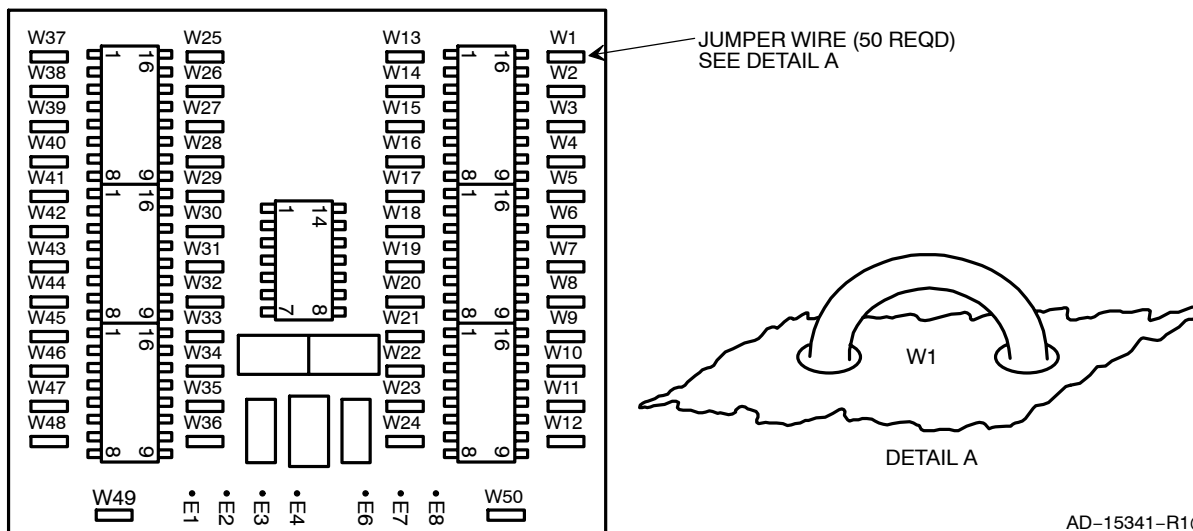

AD-15341-R1@

**Figure 3-12. Strap Assembly**

**Table 3-10. Strap Assembly Programming Instructions**

Strap Number	Functional Description																				
W1 W2	<p><b>SYSTEM (SIDE) POSITION: (B0, B1)</b></p> <p>The System (Side) Position straps define which system position the transponder is located at. Normal practice is to designate the captain's or pilot's system as Side 1, the copilot's system as Side 2, and the engineer's, center, or backup system as Side 3. The straps are defined as follows:</p> <table border="1"> <thead> <tr> <th align="center">Strap Number</th> <th align="center">W1</th> <th align="center">W2</th> <th align="center">Definition</th> </tr> </thead> <tbody> <tr> <td></td> <td align="center">Gnd</td> <td align="center">Gnd</td> <td align="center">Side 1</td> </tr> <tr> <td></td> <td align="center">Open</td> <td align="center">Gnd</td> <td align="center">Side 2</td> </tr> <tr> <td></td> <td align="center">Gnd</td> <td align="center">Open</td> <td align="center">Side 3</td> </tr> <tr> <td></td> <td align="center">Open</td> <td align="center">Open</td> <td align="center">Reserved</td> </tr> </tbody> </table>	Strap Number	W1	W2	Definition		Gnd	Gnd	Side 1		Open	Gnd	Side 2		Gnd	Open	Side 3		Open	Open	Reserved
Strap Number	W1	W2	Definition																		
	Gnd	Gnd	Side 1																		
	Open	Gnd	Side 2																		
	Gnd	Open	Side 3																		
	Open	Open	Reserved																		
W3 W4	<p><b>PARITY</b></p> <p>The Parity straps are used to make sure the strap data is valid. Straps W3 and W4 are parity bits and must be programmed as follows:</p> <p>After all other straps have been programmed, count the number of Gnd (Uncut) straps in positions W1, W2 and W5 thru W48. If the number of uncut straps is even, cut strap W3. If the number of uncut straps is odd, cut strap W4.</p> <p><b>NOTES:</b></p> <ol style="list-style-type: none"> <li>To have correct parity, either jumper W3 or W4 has to be cut, but not both.</li> <li>If parity is invalid, the transponder fails the Power-On Self-Test (POST) and discontinues operation.</li> </ol>																				



**SYSTEM DESCRIPTION AND INSTALLATION MANUAL**  
TCAS 3000 Traffic Alert and Collision Avoidance System

**Table 3-10. Strap Assembly Programming Instructions (cont)**

Strap Number	Functional Description																																								
W5	<p><b>SQUAT SWITCH POLARITY</b></p> <p>The Squat Switch Polarity strap is used to indicate the logic or signal sense of the aircraft squat switch on ground condition. If the squat switch is closed when the aircraft is on the ground, jumper W5 must be installed (Uncut). If the squat switch is closed when the aircraft is airborne, jumper W5 must be Open (Cut).</p>																																								
W6 W7 W8	<p><b>AIRCRAFT MAXIMUM TRUE AIRSPEED RANGE: (B0, B1, B2)</b></p> <p>The Aircraft Maximum True Airspeed Range straps are used to define the aircraft's maximum airspeed capability. The straps are defined as follows:</p> <table border="1"> <thead> <tr> <th align="center" colspan="3">Strap Number</th> <th align="center">Definition</th> </tr> <tr> <th align="center">W6</th> <th align="center">W7</th> <th align="center">W8</th> <th></th> </tr> </thead> <tbody> <tr> <td align="center">Gnd</td> <td align="center">Gnd</td> <td align="center">Gnd</td> <td>No Data Available</td> </tr> <tr> <td align="center">Open</td> <td align="center">Gnd</td> <td align="center">Gnd</td> <td>75 Knots or Less</td> </tr> <tr> <td align="center">Gnd</td> <td align="center">Open</td> <td align="center">Gnd</td> <td>76 to 150 Knots</td> </tr> <tr> <td align="center">Open</td> <td align="center">Open</td> <td align="center">Gnd</td> <td>151 to 300 Knots</td> </tr> <tr> <td align="center">Gnd</td> <td align="center">Gnd</td> <td align="center">Open</td> <td>301 to 600 Knots</td> </tr> <tr> <td align="center">Open</td> <td align="center">Gnd</td> <td align="center">Open</td> <td>601 to 1200 Knots</td> </tr> <tr> <td align="center">Gnd</td> <td align="center">Open</td> <td align="center">Open</td> <td>Over 1200 Knots</td> </tr> <tr> <td align="center">Open</td> <td align="center">Open</td> <td align="center">Open</td> <td>Not Assigned</td> </tr> </tbody> </table>	Strap Number			Definition	W6	W7	W8		Gnd	Gnd	Gnd	No Data Available	Open	Gnd	Gnd	75 Knots or Less	Gnd	Open	Gnd	76 to 150 Knots	Open	Open	Gnd	151 to 300 Knots	Gnd	Gnd	Open	301 to 600 Knots	Open	Gnd	Open	601 to 1200 Knots	Gnd	Open	Open	Over 1200 Knots	Open	Open	Open	Not Assigned
Strap Number			Definition																																						
W6	W7	W8																																							
Gnd	Gnd	Gnd	No Data Available																																						
Open	Gnd	Gnd	75 Knots or Less																																						
Gnd	Open	Gnd	76 to 150 Knots																																						
Open	Open	Gnd	151 to 300 Knots																																						
Gnd	Gnd	Open	301 to 600 Knots																																						
Open	Gnd	Open	601 to 1200 Knots																																						
Gnd	Open	Open	Over 1200 Knots																																						
Open	Open	Open	Not Assigned																																						
W9 thru W32 (LSB – MSB)	<p><b>MODE S ADDRESS: (B0 THRU B23)</b></p> <p>The Mode S Address is a unique 24-bit code assigned to each aircraft. Straps W9 thru W32 are used to program this 24-bit binary number. The straps must be set according to this binary number representation. Each binary 1 represents a Cut strap and each binary 0 represents an Uncut strap. Strap W9 represents the least significant digit of the binary number and strap W32 represents the most significant digit of the binary number. The initial board condition with all jumpers is a 0 address.</p> <p><b>NOTE:</b> An address of all 0's or all 1's is an illegal address, and can cause the aircraft to be invisible to TCAS II equipped aircraft in flight. Never use an illegal address for an installed system.</p>																																								
W33 W34	<p><b>ALTITUDE SOURCE: (B0, B1)</b></p> <p>The Altitude Source straps select the type of altitude information used by the transponder. Altitude information can be generated by an encoding altimeter in the form of Gray aka Gillham code, or by a digital Air Data Computer. The straps are defined as follows:</p> <table border="1"> <thead> <tr> <th align="center" colspan="2">Strap Number</th> <th align="center">Definition</th> </tr> <tr> <th align="center">W33</th> <th align="center">W34</th> <th></th> </tr> </thead> <tbody> <tr> <td align="center">Gnd</td> <td align="center">Gnd</td> <td>Gillham Gray Code Altitude Source</td> </tr> <tr> <td align="center">Open</td> <td align="center">Gnd</td> <td>ARINC 429 Altitude Source</td> </tr> <tr> <td align="center">Gnd</td> <td align="center">Open</td> <td>ARINC 575 Altitude Source</td> </tr> <tr> <td align="center">Open</td> <td align="center">Open</td> <td>RSB Altitude Source</td> </tr> </tbody> </table> <p><b>NOTE:</b> The RSB altitude source is a valid selection only when the transponder receives tuning information from an RCB bus.</p>	Strap Number		Definition	W33	W34		Gnd	Gnd	Gillham Gray Code Altitude Source	Open	Gnd	ARINC 429 Altitude Source	Gnd	Open	ARINC 575 Altitude Source	Open	Open	RSB Altitude Source																						
Strap Number		Definition																																							
W33	W34																																								
Gnd	Gnd	Gillham Gray Code Altitude Source																																							
Open	Gnd	ARINC 429 Altitude Source																																							
Gnd	Open	ARINC 575 Altitude Source																																							
Open	Open	RSB Altitude Source																																							



**SYSTEM DESCRIPTION AND INSTALLATION MANUAL**  
TCAS 3000 Traffic Alert and Collision Avoidance System

**Table 3-10. Strap Assembly Programming Instructions (cont)**

Strap Number	Functional Description																		
W35	<p><b>DLP INSTALLED</b></p> <p>The DLP Installed strap specifies whether the transponder is connected to an Airborne Data Link Processor system. The strap is selected as follows:</p> <p align="center">Gnd = DLP is not installed Open = DLP is installed</p>																		
W36	<p><b>TCAS II INSTALLED</b></p> <p>The TCAS II Installed strap specifies whether the transponder is connected to a TCAS II system. The strap is selected as follows:</p> <p align="center">Gnd = TCAS II is not installed Open = TCAS II is installed</p> <p><b>NOTE:</b> If both TCAS II and TCAS I (strap W40) are set (Grounded), the transponder will default to TCAS II operation. Both straps should not be cut.</p>																		
W37 W38	<p><b>ANTENNA CABLE INSTALLATION: (B0, B1)</b></p> <p>The Antenna Cable Install straps are used to set the system for either a single (bottom) antenna installation, or a diversity installation. In the diversity installation, the straps adjust for the difference in RF propagation times through the upper and lower antenna cables which occur because of their dissimilar lengths. The antenna cable delay is selected as follows:</p> <table border="1" style="width: 100%; border-collapse: collapse;"> <thead> <tr> <th align="center" colspan="2">Strap Number</th> <th align="center">Definition</th> </tr> <tr> <th align="center">W37</th> <th align="center">W38</th> <th></th> </tr> </thead> <tbody> <tr> <td align="center">Gnd</td> <td align="center">Gnd</td> <td>Single (bottom) Antenna Installation</td> </tr> <tr> <td align="center">Open</td> <td align="center">Gnd</td> <td>Top &gt; Bottom Cable Length, Differential Delay &gt;40 nanoseconds</td> </tr> <tr> <td align="center">Gnd</td> <td align="center">Open</td> <td>Bottom &gt; Top Cable Length, Differential Delay &gt;40 nanoseconds</td> </tr> <tr> <td align="center">Open</td> <td align="center">Open</td> <td>Differential Delay is &lt;40 nanoseconds</td> </tr> </tbody> </table> <p><b>NOTE:</b> The differential delay is equal to two times the length (in feet) of the difference between the top and bottom antenna cable lengths, times the characteristic delay (nanoseconds / feet) of the cable type in use.</p>	Strap Number		Definition	W37	W38		Gnd	Gnd	Single (bottom) Antenna Installation	Open	Gnd	Top > Bottom Cable Length, Differential Delay >40 nanoseconds	Gnd	Open	Bottom > Top Cable Length, Differential Delay >40 nanoseconds	Open	Open	Differential Delay is <40 nanoseconds
Strap Number		Definition																	
W37	W38																		
Gnd	Gnd	Single (bottom) Antenna Installation																	
Open	Gnd	Top > Bottom Cable Length, Differential Delay >40 nanoseconds																	
Gnd	Open	Bottom > Top Cable Length, Differential Delay >40 nanoseconds																	
Open	Open	Differential Delay is <40 nanoseconds																	
W39	<p><b>TCAS TA DISPLAY ENABLE</b></p> <p>The TCAS Display Enable strap allows the TCAS display to be either tunable or fixed. The strap is not processed by the transponder, but is used by a RMU when an RSB tuning source is selected. The strap is not used by ARINC tuning sources. The strap definition is as follows:</p> <p align="center">Gnd = TA Display is tunable (ON / OFF / AUTO POP-UP) modes selectable Open = TA Display is not selectable (AUTO POP-UP mode only)</p>																		
W40	<p><b>TCAS I INSTALLED</b></p> <p>The TCAS I Installed strap specifies whether the transponder is connected to a TCAS I system. The strap is selected as follows:</p> <p align="center">Gnd = TCAS I is not installed Open = TCAS I is installed</p> <p><b>NOTE:</b> If both TCAS I and TCAS II (strap W36) are set (Grounded), the transponder will default to TCAS II operation. Both straps should not be cut.</p>																		





**SYSTEM DESCRIPTION AND INSTALLATION MANUAL**  
TCAS 3000 Traffic Alert and Collision Avoidance System

**Table 3-10. Strap Assembly Programming Instructions (cont)**

<b>Strap Number</b>	<b>Functional Description</b>
W41	<b>ALTITUDE RESOLUTION</b> The Altitude Resolution strap allows the transponder output to the TCAS (label 203) to be either 100 foot resolution or 1 foot resolution. The strap definition is as follows: Gnd = 1 Foot Resolution Open = 100 Foot Resolution <b>NOTE:</b> Most ARINC altitude inputs require 1 foot resolution.
W42 thru W48	<b>RESERVED FUNCTION</b> These straps are not used. The jumpers should be installed (Uncut).
W49 W50	Jumpers W49 and W50 are not part of the 48-bit serial data pulse train and are not used on RCZ-852 Transponder installations. The jumpers should be installed (Uncut).



**SYSTEM DESCRIPTION AND INSTALLATION MANUAL**  
TCAS 3000 Traffic Alert and Collision Avoidance System  
**LOADING/GRADIENT SPECIFICATIONS**

**1. General**

This section contains the loading and gradient specifications for the input and output signals of each component of the TCAS 3000 system.

**2. Loading and Gradient Specifications**

<b>Component</b>	<b>Table No.</b>
TCAS 3000 Computer Unit Loading/Gradient Specifications	Table 4-1
ACSS Dual Mode S Control Panel Loading/Gradient Specifications	Table 4-2
ACSS ATCRBS-Mode S Control Panel Loading/Gradient Specifications	Table 4-3
Gables Control Panel Loading/Gradient Specifications	Table 4-4
41-Pin VSI/TRA Loading/Gradient Specifications	Table 4-5
55-Pin VSI/TRA Loading/Gradient Specifications	Table 4-6
Pressure Transducer Module Loading/Gradient Specifications	Table 4-7
XS-950 Data Link Transponder Loading/Gradient Specifications	Table 4-8
RCZ-852 Diversity Mode S Transponder Loading/Gradient Specifications	Table 4-9



**SYSTEM DESCRIPTION AND INSTALLATION MANUAL**  
TCAS 3000 Traffic Alert and Collision Avoidance System

**Table 4-1. TCAS 3000 Computer Unit Loading/Gradient Specifications**

Connector Pin Designation	Functional Description
<b>TCAS Computer Unit Right Middle Plug (RMP)</b>	
<b>RMP-1A, RMP-1B, RMP-1C, RMP-1D</b>	<b>Reserved Discrete Outputs</b>
<b>RMP-1E</b>	<b>TA Display Enable Discrete Output (NO)</b> This output is a ground/open type discrete used by the weather radar display to place the radar in standby mode. A ground on this pin enables the weather radar display.
<b>RMP-1F</b>	<b>Corrective Aural Advisory Discrete Output (NO)</b> This aural advisory discrete output is a ground/open type discrete used to control external equipment that generate tones to accompany TCAS advisories. The output is active whenever a corrective advisory (RA that requires a corrective maneuver) is issued. The output remains active for the duration of the synthesized voice unless it is cancelled by the cancel discrete at RMP-3D. Only one aural advisory is active at a time. The corrective discrete and preventative discrete at RMP-1K are mutually exclusive. The active state is ground and the inactive state is open. This pin is reserved on the -XX001 TCAS CU.
<b>RMP-1G, RMP-1H</b>	<b>Reserved</b>
<b>RMP-1J</b>	<b>Climb Inhibit No. 1 Discrete Input (NO)</b> This input is a ground/open type discrete used to provide information to the TCAS CU whether to assume the aircraft cannot achieve a climb rate of 1500 feet per minute (FPM). The climb inhibit discrete inputs are designed in pairs (No. 1 and No. 2 at RMP-13G, or No. 3 at RBP-5J and No. 4 at RBP-5K) but can be wired as a single input or in conjunction with other aircraft operations to achieve airframe customization of the climb inhibit feature. The 1500 FPM climb inhibit function is assumed whenever No. 1 and No. 2 are ground or No. 3 and No. 4 are ground.
<b>RMP-1K</b>	<b>Preventive Aural Advisory Discrete Output (NO)</b> Same as RMP-1F, except this discrete is active whenever a preventative advisory (RA that directs the flight crew to avoid certain maneuvers or maintain flight path) is issued.
<b>RMP-2A</b>	<b>Traffic Aural Advisory Discrete Output (NO)</b> Same as RMP-1F, except this discrete is active during a traffic advisory when information is being given to the flight crew regarding other aircraft in the immediate vicinity. No suggested maneuver is issued. This output is inhibited if either the corrective or preventative output is active.
<b>RMP-2B, RMP-2C</b>	<b>Reserved</b>
<b>RMP-2D</b>	<b>Advisory/Announce Common</b> This is the return line for the aural and visual advisory discrete outputs.



**SYSTEM DESCRIPTION AND INSTALLATION MANUAL**  
TCAS 3000 Traffic Alert and Collision Avoidance System

**Table 4-1. TCAS 3000 Computer Unit Loading/Gradient Specifications (cont)**

<b>Connector Pin Designation</b>	<b>Functional Description</b>
<b>RMP-2E</b>	<b>Spare Pin</b>
<b>RMP-2F, 2G</b>	<p><b>8-Ohm Audio Output: (RMP-2F [HI], RMP-2G [LO])</b></p> <p>This is a synthesized voice output supplied by the TCAS computer unit. Its level is programmable up to 4 Watts into an 8-ohm speaker. All aural traffic and resolution advisories are announced over this output. See RBP-7A for audio level programming.</p>
<b>RMP-2H, 2J</b>	<p><b>Radio Altimeter No. 1 ARINC 552/Analog Input: (RMP-2H [HI], RMP-2J [LO])</b></p> <p>Normal aircraft configurations include either two digital or two analog radio altimeter sources. The TCAS computer unit attempts to establish which type is present in order to obtain data from one of the two available sources. TCAS first checks the radio altimeter No. 1 valid flag at RMP-2K. If No. 1 is not valid then No. 2 valid is checked at RBP-3C. If neither are valid then TCAS checks digital source No. 1 for valid data on the ARINC 429 bus at RMP-13H and RMP-13J. If none of the above are valid then the TCAS checks the digital source No. 2 for valid data on the ARINC 429 bus at RBP-3D and RBP-3E. This process is repeated until a valid flag or data is detected.</p> <p>Until a valid source is found, the TCAS computer unit inhibits all surveillance, CAS, and TA/RA display functions, records failures in maintenance memory, and sets the TCAS system status discrete output at RMP-13K to invalid. The TCAS computer unit uses radio altitude to inhibit advisories and aural annunciation when in close proximity to the ground. This analog input No. 1, as well as analog input No. 2, can accept data as a dc voltage from several types of radio altimeters. The type of radio altimeter is selected using the program pins RMP-12B and RMP-12H thru RMP-12K.</p>
<b>RMP-2K</b>	<p><b>Radio Altimeter No. 1 Valid Input (PO)</b></p> <p>See RMP-2H. A valid condition is greater than 18.5 V dc. An invalid is open circuit.</p>
<b>RMP-3A</b>	<p><b>Corrective Visual Advisory Discrete Output (NO)</b></p> <p>The visual advisory discrete outputs are ground/open type discrettes used to operate the annunciator lights on the displays. This output is activated whenever a corrective aural advisory is issued. The output remains active for the duration of the advisory unless cancelled by the cancel discrete at RMP-3D. Only one visual advisory is active at a time. The active state is ground and the inactive state is open.</p>
<b>RMP-3B</b>	<p><b>Preventive Visual Advisory Discrete Output (NO)</b></p> <p>Same as RMP-3A, except this discrete is activated whenever a preventative aural advisory is issued.</p>
<b>RMP-3C</b>	<p><b>Traffic Visual Advisory Discrete Output (NO)</b></p> <p>Same as RMP-3A, except this discrete is active during a traffic advisory.</p>
<b>RMP-3D</b>	<p><b>Cancel Discrete Input (NO)</b></p> <p>This input discrete provides a means of canceling aural and visual alerts. It should be connected to a cancel button (momentary ground type), if used. Groundprox/Windshear has priority over the cancel button. Open is the inactive state and a momentary ground (less than 50 ohms) produces the active state, canceling any active aural or visual alert.</p>



**SYSTEM DESCRIPTION AND INSTALLATION MANUAL**  
 TCAS 3000 Traffic Alert and Collision Avoidance System

**Table 4-1. TCAS 3000 Computer Unit Loading/Gradient Specifications (cont)**

Connector Pin Designation	Functional Description
<b>RMP-3E</b>	<b>Spare Pin</b>
<b>RMP-3F, 3G</b>	<b>600-Ohm Audio Output: [RMP-3F (HI), RMP-3G (LO)]</b> This is a synthesized voice output supplied by the TCAS computer unit. Its level is programmable up to 80 milliwatts into a 600-ohm audio distribution system. All aural traffic and resolution advisories are annunciated over this output. See RBP-7A for audio level programming.
<b>RMP-3H</b>	<b>Spare Pins</b>
<b>RMP-3J, RMP-3K</b>	Reserved for future use.
<b>RMP-4A</b>	Reserved for future use.
<b>RMP-4B</b>	Reserved for future use.
<b>RMP-4C</b>	Reserved for future use.
<b>RMP-4D</b>	<b>Shield Ground</b> Reserved for future use.
<b>RMP-4E</b>	Reserved for future use.
<b>RMP-4F</b>	Reserved for future use.
<b>RMP-4G</b>	Reserved for future use.
<b>RMP-4H</b>	Reserved for future use.
<b>RMP-4J</b>	Reserved for future use.
<b>RMP-4K</b>	<b>Attitude Valid Discrete Input</b> Reserved for future use.



**SYSTEM DESCRIPTION AND INSTALLATION MANUAL**  
TCAS 3000 Traffic Alert and Collision Avoidance System

**Table 4-1. TCAS 3000 Computer Unit Loading/Gradient Specifications (cont)**

Connector Pin Designation	Functional Description
RMP-5A	Reserved for future use.
RMP-5B	Reserved for future use.
RMP-5C	Reserved for future use.
RMP-5D	Reserved for future use.
RMP-5E	<b>ADS-B Program Input</b> Intruder File Enable
RMP-5F	<b>ADS-B Program Input</b> GP Bus enable
RMP-5G	<b>ADS-B Program Input</b> Future Spare
RMP-5H	Reserved for future use.
RMP-5J	Reserved for future use.
RMP-5K	<b>Air Ground Discrete Input (NO): (Weight-On-Wheels)</b> This discrete input to the TCAS computer unit indicates the status of the Air/Ground or Weight-On-Wheels (WOW) switch. TCAS filters this input to make sure it remains in a steady state a minimum of 4 seconds before an Air/Ground transition is recorded. An open indicates the aircraft is airborne and a ground indicates the aircraft is on the ground. Inputs should be diode isolated from each other.
RMP-6A, 6B	<b>ARINC 429 Performance Limit Input: [RMP-6A (A), RMP-6B (B)]</b> This input is provided for future applications to receive climb rate performance limit information from an external device such as a Flight Management Computer.
RMP-6C	<b>Magnetic Heading Valid Discrete Input</b> Reserved for future use.
RMP-6D	<b>Performance Limit Discrete Input (NO)</b> This input provides the TCAS computer unit with an input from the Flight Management Computer (or equivalent) which indicates when the aircraft cannot achieve a 1500 FPM climb rate. When this input is ground, the climb rate is not limited and no action is needed by the TCAS computer unit. When this input is open, the climb rate is limited when the aircraft is above the value set by the altitude limit program pins (RMP-6E thru RMP-6J).



**SYSTEM DESCRIPTION AND INSTALLATION MANUAL**  
TCAS 3000 Traffic Alert and Collision Avoidance System

**Table 4-1. TCAS 3000 Computer Unit Loading/Gradient Specifications (cont)**

Connector Pin Designation	Functional Description
<b>RMP-6E</b>	<b>2000 FT Altitude Limit Program Pin (NO)</b> This pin, along with pins RMP-6F thru RMP-6J, select the “can’t climb” altitude in 2,000-foot increments up to 62,000 feet. This is the altitude the aircraft is not able to achieve a 0.25 G vertical acceleration to a 1500 FPM climb rate for an altitude gain of 750 feet above a certain altitude under all circumstances. The “can’t climb” altitude is selected by connecting jumper wires from altitude limit program pins to the program common pin (RMP-6K).
<b>RMP-6F</b>	<b>4000 FT Altitude Limit Program Pin (NO)</b> See RMP-6E.
<b>RMP-6G</b>	<b>8000 FT Altitude Limit Program Pin (NO)</b> See RMP-6E.
<b>RMP-6H</b>	<b>16000 FT Altitude Limit Program Pin (NO)</b> See RMP-6E.
<b>RMP-6J</b>	<b>32000 FT Altitude Limit Program Pin (NO)</b> See RMP-6E.
<b>RMP-6K</b>	<b>Program Common</b> See RMP-6E.
<b>RMP-7A, 7B</b>	<b>ARINC 429 Magnetic Heading/Attitude Input: [RMP-7A (A), RMP-7B (B)]</b> Reserved for future use
<b>RMP-7C, 7D</b>	<b>ARINC 429 TA/RA Display No. 1 Output: [RMP-7C (A), RMP-7D (B)]</b> This is one of two ARINC 429 high speed bus outputs that supplies data to the TA/RA display such as a VSI/TRA or EFIS. The other output (TA/RA Display No. 2) is at RMP-7G and -7H. The TA/RA Display No. 1 outputs are also connected to the front (PDL) connector, which is used to supply display information to maintenance displays. See J1-33 and J1-34.
<b>RMP-7E</b>	<b>TA/RA Display No. 1 Status Discrete Input (NO)</b> Two display status discrete inputs are provided by the TCAS computer unit at RMP-7E (TA/RA Display No. 1) and RMP-7J (TA/RA Display No. 2). A ground on either of these inputs is interpreted by TCAS to mean the display associated with that input is operating normally and is capable of displaying the TA/RA information, and that its data bus is active. An open indicates the inability of the display to present advisories or indicates its data bus is inactive.
<b>RMP-7F</b>	<b>Spare Pin</b>
<b>RMP-7G, 7H</b>	<b>ARINC 429 TA/RA Display No. 2 Output: [RMP-7G (A), RMP-7H (B)]</b> See RMP-7C and -7D.
<b>RMP-7J</b>	<b>TA/RA Display No. 2 Status Discrete Input (NO)</b> See RMP-7E.
<b>RMP-7K</b>	<b>Spare Pin</b>



**SYSTEM DESCRIPTION AND INSTALLATION MANUAL**  
TCAS 3000 Traffic Alert and Collision Avoidance System

**Table 4-1. TCAS 3000 Computer Unit Loading/Gradient Specifications (cont)**

<b>Connector Pin Designation</b>	<b>Functional Description</b>
<b>RMP-8A, 8B</b>	<p><b>ARINC 429 Data Loader Input: [RMP-8A (A), RMP-8B (B)]</b></p> <p>These pins are used when the TCAS computer unit is communicating with an ARINC 603 or 615 airborne data loader (ADL) through the rear ARINC 600 connector. The data loader programs the program memory in the TCAS computer unit per the data loader function specified. The ADL and portable data loader (PDL) ARINC 429 inputs have separate receiver busses to allow for simultaneous connection of the ADL and PDL. These pins are also connected to the front (PDL) connector on the front of the unit. See J1-1 and J1-2.</p>
<b>RMP-8C,8D</b>	<p><b>TA/RA Display Control ARINC 429 Input #1: [RMP-8C (A), RMP-8D (B)]</b></p>
<b>RMP-8E, 8F</b>	<p><b>ARINC 429 Bus Input: [RMP-8E (A), RMP-8F (B)]</b></p> <p>Reserved for future use.</p>
<b>RMP-8G, 8H</b>	<p><b>TA/RA Display Control ARINC 429 Input #2: [RMP-8G (A), RMP-8H (B)]</b></p>
<b>RMP-8J, 8K</b>	<p><b>ARINC 429 ADS-B No. 2 Input: [RMP-8J (A), RMP-8K (B)]</b></p> <p>Reserved for future use.</p>
<b>RMP-9A, 9B</b>	<p><b>ARINC 429 Data Loader Output: [RMP-9A (A), RMP-9B (B)]</b></p> <p>These pins are used when the TCAS computer unit is communicating with an ARINC 603 or 615 airborne data loader (ADL) through the rear ARINC 600 connector. This connection is used to transmit data to the ADL during data loading operations. These pins are also connected to the front (PDL) connector on the front of the unit. See J1-8 and J1-9.</p>
<b>RMP-9C, 9D</b>	<p><b>ARINC 429 ADS-B No. 1 Output: [RMP-9C (A), RMP-9D (B)]</b></p> <p>Reserved for future use.</p>
<b>RMP-9E, 9F</b>	<p><b>ARINC 429 Bus Output: [RMP-9E (A), RMP-9F (B)]</b></p> <p>Reserved for future use.</p>
<b>RMP-9G, 9H</b>	<p><b>ARINC 429 Bus Output: [RMP-9G (A), RMP-9H (B)]</b></p> <p>Reserved for future use.</p>
<b>RMP-9J, 9K</b>	<p><b>ARINC 429 ADS-B No. 2 Output: [RMP-9J (A), RMP-9K (B)]</b></p> <p>Reserved for future use.</p>





**SYSTEM DESCRIPTION AND INSTALLATION MANUAL**  
TCAS 3000 Traffic Alert and Collision Avoidance System

**Table 4-1. TCAS 3000 Computer Unit Loading/Gradient Specifications (cont)**

Connector Pin Designation	Functional Description
RMP-10A RMP-10B RMP-10C	<b>ADS-B Program Inputs</b> Reserved for future use.
RMP-10D	<b>Single Mode S Transponder Input</b> This pin must be grounded when system is configured with a single Mode S transponder. Failure to ground this program pin in a single Mode S installation will result in XPNDR bus faults displayed on fault data LEDs.
RMP-10E Thru RMP-10J	<b>Reserved Program Inputs</b> Reserved for future use.
RMP-10K	<b>ADS-B Surveillance Program Input</b> This program pin enables passive surveillance using ADS-B DF-17 extended squitters. A ground on this pin enables ADS-B surveillance and an open disables ADS-B surveillance.
RMP-11A	<b>Reserved Program Input</b> Reserved for future use.
RMP-11B	<b>Traffic Display of Flight ID Program Input</b> This program pin allows traffic display of flight identification information from a transponder to be output on the TA/TA displays. A ground on this pin enables this function and an open disables the function.
RMP-11C	<b>Male Voice Program Input</b> This program input is intended to allow audio annunciation to be selectable for either male or female genders. A ground on this pin selects the male voice and an open selects the female voice.
RMP-11D	<b>Flight Data Recorder ARINC 429 and Extended Maintenance Log Program Input</b> This program pin is used to specify whether the ARINC 429 Flight Data Recorder (FDR) is to be used. An open on this pin means that the FDR is not utilized. A ground indicates that flight data is output as high-speed ARINC 429 data on RA Display No. 1 and No. 2 busses. While the FDR is enabled, normal low-speed RA display bus operation is not available. A ground also enables RA/TA events recording in memory.
RMP-11E Thru RMP-11K	<b>Reserved Data Bus Inputs</b> Reserved for future use.
RMP-12A	<b>Reserved Program Input</b> Reserved for future use.



**SYSTEM DESCRIPTION AND INSTALLATION MANUAL**  
TCAS 3000 Traffic Alert and Collision Avoidance System

**Table 4-1. TCAS 3000 Computer Unit Loading/Gradient Specifications (cont)**

Connector Pin Designation	Functional Description																																																																																																			
<b>RMP-12B</b>	<p><b>Radio Altimeter Type Select Program Input No. 4 (NO)</b></p> <p>The TCAS computer unit uses radio altitude to inhibit advisories and aural annunciation when in close proximity to the ground. This analog input No. 1, as well as analog input No. 2 can accept data as a dc voltage from several types of radio altimeters. Program pin RMP-12B is used, along with program pins RMP-12H, -12J, and -12K, to identify the type of analog radio altimeter installed.</p> <p>ARINC 552, Collins BCA, and metric type radio altimeters can be selected. In addition radio altimeter inputs can be selected which include AHV-6, NR-AS-10A, LPIA, and APN-232 CARA. The program pin inputs use ground/open logic levels. All unassigned program pin combinations are invalid and should not be selected. Pin RMP-6K can be used to supply a ground.</p> <table border="1" data-bbox="431 751 1490 1318"> <thead> <tr> <th colspan="4" data-bbox="630 751 781 783">Program Pin</th> <th data-bbox="1101 783 1276 814" rowspan="2">Altimeter Type</th> </tr> <tr> <th data-bbox="431 783 553 814">RMP-12K</th> <th data-bbox="553 783 675 814">RMP-12J</th> <th data-bbox="675 783 797 814">RMP-12H</th> <th data-bbox="797 783 992 814">RMP-12B</th> </tr> </thead> <tbody> <tr><td>Open</td><td>Open</td><td>Open</td><td>Open</td><td>ARINC 552/552A</td></tr> <tr><td>Open</td><td>Open</td><td>Open</td><td>Ground</td><td>Collins BCA</td></tr> <tr><td>Open</td><td>Open</td><td>Ground</td><td>Open</td><td>Metric Altimeter No. 1</td></tr> <tr><td>Open</td><td>Open</td><td>Ground</td><td>Ground</td><td>Unassigned</td></tr> <tr><td>Open</td><td>Ground</td><td>Open</td><td>Open</td><td>Metric Altimeter No. 2</td></tr> <tr><td>Open</td><td>Ground</td><td>Open</td><td>Ground</td><td>Unassigned</td></tr> <tr><td>Open</td><td>Ground</td><td>Ground</td><td>Open</td><td>Metric Altimeter No. 3</td></tr> <tr><td>Open</td><td>Ground</td><td>Ground</td><td>Ground</td><td>Unassigned</td></tr> <tr><td>Ground</td><td>Open</td><td>Open</td><td>Open</td><td>Metric Altimeter No. 4</td></tr> <tr><td>Ground</td><td>Open</td><td>Open</td><td>Ground</td><td>Unassigned</td></tr> <tr><td>Ground</td><td>Open</td><td>Ground</td><td>Open</td><td>Military AHV6 (Linear)</td></tr> <tr><td>Ground</td><td>Open</td><td>Ground</td><td>Ground</td><td>Military AHV6 (Log)</td></tr> <tr><td>Ground</td><td>Ground</td><td>Open</td><td>Open</td><td>Military NR-AS-10A (Alternate)</td></tr> <tr><td>Ground</td><td>Ground</td><td>Open</td><td>Ground</td><td>Military APN-232 CARA</td></tr> <tr><td>Ground</td><td>Ground</td><td>Ground</td><td>Open</td><td>Military LPIA</td></tr> <tr><td>Ground</td><td>Ground</td><td>Ground</td><td>Ground</td><td>Military NR-AS-10A (Curve Fit)</td></tr> </tbody> </table> <p>Each of the military radio altimeter types provide two outputs that are connected to the TCAS computer unit input pins. The two altimeter outputs are the Analog Data Output and Analog Data Reliability Signal. The Data Reliability Signal is connected to RMP-2K for source No. 1 and RBP-3C for source No. 2, except for altimeter type LPIA. For radio altimeter type LPIA, the Analog Data Output must be connected to RMP-2H (HI) and RMP-2J (LO), the Analog Data Reliability Signal must be connected to RBP-3A (HI) and RBP-3B (LO), and the inputs RMP-2K and RMP-3C are set high (greater than 18.5 V).</p> <p>The metric radio altimeters are defined as follows:</p> <table border="1" data-bbox="574 1612 1295 1820"> <thead> <tr> <th data-bbox="574 1612 683 1665">Metric Altimeter</th> <th data-bbox="721 1640 833 1665">Definition</th> </tr> </thead> <tbody> <tr><td>No. 1</td><td>Metric unit- 1000 meter range, 25 mV/M scaling</td></tr> <tr><td>No. 2</td><td>Metric unit- 1000 meter range, 20 mV/M scaling</td></tr> <tr><td>No. 3</td><td>Metric unit- 1500 meter range, 20 mV/M scaling</td></tr> <tr><td>No. 4</td><td>Metric unit- 750 meter range, 50 mV/M scaling</td></tr> </tbody> </table>	Program Pin				Altimeter Type	RMP-12K	RMP-12J	RMP-12H	RMP-12B	Open	Open	Open	Open	ARINC 552/552A	Open	Open	Open	Ground	Collins BCA	Open	Open	Ground	Open	Metric Altimeter No. 1	Open	Open	Ground	Ground	Unassigned	Open	Ground	Open	Open	Metric Altimeter No. 2	Open	Ground	Open	Ground	Unassigned	Open	Ground	Ground	Open	Metric Altimeter No. 3	Open	Ground	Ground	Ground	Unassigned	Ground	Open	Open	Open	Metric Altimeter No. 4	Ground	Open	Open	Ground	Unassigned	Ground	Open	Ground	Open	Military AHV6 (Linear)	Ground	Open	Ground	Ground	Military AHV6 (Log)	Ground	Ground	Open	Open	Military NR-AS-10A (Alternate)	Ground	Ground	Open	Ground	Military APN-232 CARA	Ground	Ground	Ground	Open	Military LPIA	Ground	Ground	Ground	Ground	Military NR-AS-10A (Curve Fit)	Metric Altimeter	Definition	No. 1	Metric unit- 1000 meter range, 25 mV/M scaling	No. 2	Metric unit- 1000 meter range, 20 mV/M scaling	No. 3	Metric unit- 1500 meter range, 20 mV/M scaling	No. 4	Metric unit- 750 meter range, 50 mV/M scaling
Program Pin				Altimeter Type																																																																																																
RMP-12K	RMP-12J	RMP-12H	RMP-12B																																																																																																	
Open	Open	Open	Open	ARINC 552/552A																																																																																																
Open	Open	Open	Ground	Collins BCA																																																																																																
Open	Open	Ground	Open	Metric Altimeter No. 1																																																																																																
Open	Open	Ground	Ground	Unassigned																																																																																																
Open	Ground	Open	Open	Metric Altimeter No. 2																																																																																																
Open	Ground	Open	Ground	Unassigned																																																																																																
Open	Ground	Ground	Open	Metric Altimeter No. 3																																																																																																
Open	Ground	Ground	Ground	Unassigned																																																																																																
Ground	Open	Open	Open	Metric Altimeter No. 4																																																																																																
Ground	Open	Open	Ground	Unassigned																																																																																																
Ground	Open	Ground	Open	Military AHV6 (Linear)																																																																																																
Ground	Open	Ground	Ground	Military AHV6 (Log)																																																																																																
Ground	Ground	Open	Open	Military NR-AS-10A (Alternate)																																																																																																
Ground	Ground	Open	Ground	Military APN-232 CARA																																																																																																
Ground	Ground	Ground	Open	Military LPIA																																																																																																
Ground	Ground	Ground	Ground	Military NR-AS-10A (Curve Fit)																																																																																																
Metric Altimeter	Definition																																																																																																			
No. 1	Metric unit- 1000 meter range, 25 mV/M scaling																																																																																																			
No. 2	Metric unit- 1000 meter range, 20 mV/M scaling																																																																																																			
No. 3	Metric unit- 1500 meter range, 20 mV/M scaling																																																																																																			
No. 4	Metric unit- 750 meter range, 50 mV/M scaling																																																																																																			



**SYSTEM DESCRIPTION AND INSTALLATION MANUAL**  
TCAS 3000 Traffic Alert and Collision Avoidance System

**Table 4–1. TCAS 3000 Computer Unit Loading/Gradient Specifications (cont)**

Connector Pin Designation	Functional Description
<b>RMP–12C</b>	<b>RA/TA Block Transfer Program Input (NO)</b> This program input determines the type of block transfer that is made from the TCAS computer unit to the TA/RA displays. If this pin is grounded, the TCAS computer unit transmits in ACSS BCA EFIS format. If the TCAS computer unit senses an open at this pin, it transmits in ARINC 735 format.
<b>RMP–12D</b>	<b>Reserved Program Input</b>
<b>RMP–12E</b>	<b>Reserved Program Input</b>
<b>RMP–12F</b>	<b>Spare Pin</b>
<b>RMP–12G</b>	<b>Option Parity Program Input</b> The TCAS computer unit uses nine discrete program input pins to determine which options have been selected by the installer. Eight of these pins are used to determine option selections. The ninth pin (RMP–12G) is used to determine parity for the eight option selection pins (RMP–10G, –10H, –10J, –10K, –11A, –11B, –11C, and –11D). To determine parity, count the number of option pins that are grounded. If the number of pins that are grounded is an odd number (1, 3, 5, 7), ground pin RMP–12G. If the number of grounded pins in the option group is an even number (0, 2, 4, 6, 8), leave pin RMP–12G open.
<b>RMP–12H</b>	<b>Analog Radio Altimeter Type Select Program Input No. 3 (NO)</b> See RMP–12B.
<b>RMP–12J</b>	<b>Analog Radio Altimeter Type Select Program Input No. 2 (NO)</b> See RMP–12B.
<b>RMP–12K</b>	<b>Analog Radio Altimeter Type Select Program Input No. 1 (NO)</b> See RMP–12B.
<b>RMP–13A, 13B</b>	<b>RA Display No. 1/ARINC 429 Data Recorder Output: [RMP–13A (A), RMP–13B (B)]</b> These ARINC 429 outputs are configured to output either RA information or for use as an ARINC 429 data recorder function. The output is configured by program pin RMP–11D. When RMP–11D is open (standard configuration), the bus is configured for low-speed ARINC 429 operation and RA information is output according to the format specified for the RA display bus in ARINC 735. When RMP–11D is grounded, the bus is configured for high-speed ARINC 429 operation and the output supplies TA and RA information to a 429 data recorder.
<b>RMP–13C, 13D</b>	<b>RA Display No. 2/ARINC 429 Data Recorder Output: [RMP–13C (A), RMP–13D (B)]</b> See RMP–13A.
<b>RMP–13E</b>	<b>RA Display No. 2 Status Discrete Input (NO)</b> This input provides the functional status of RA Display No. 2. A ground on this pin indicates a valid display. If this discrete is not used by the RA Display, connect to aircraft ground to prevent RA DISPLAY No. 2 fail message during self-test.



**SYSTEM DESCRIPTION AND INSTALLATION MANUAL**  
TCAS 3000 Traffic Alert and Collision Avoidance System

**Table 4-1. TCAS 3000 Computer Unit Loading/Gradient Specifications (cont)**

<b>Connector Pin Designation</b>	<b>Functional Description</b>
<b>RMP-13F</b>	<b>Landing Gear Discrete Input (NO)</b> The TCAS computer unit monitors this discrete that indicates the landing gear position. An open indicates the gear is retracted (gear is up) and a ground indicates the gear is extended (gear is down).
<b>RMP-13G</b>	<b>Climb Inhibit No. 2 Discrete Input (NO)</b> See RMP-1J.
<b>RMP-13H, 13J</b>	<b>Radio Altimeter No. 1 Input: [RMP-13H (A), RMP-13J (B)]</b> This input is provided for ARINC 429 altitude inputs from an ARINC 707 digital radio altimeter. Radio altitude data is used for computation of sensitivity level, inhibit descend advisories, and inhibit aural annunciation when in close proximity to the ground. Also see RMP-2H.
<b>RMP-13K</b>	<b>TCAS System Valid Discrete Output (NO)</b> This discrete output indicates the health status of the TCAS computer unit to other avionics systems that monitor TCAS system status. This output is used in retrofit installations where instrumentation needs to monitor TCAS status. A ground at this pin indicates normal TCAS operation. An open indicates a TCAS fault.
<b>RMP-14A, 14B</b>	<b>ARINC 429 TX Coordination Bus No. 2 Output: [RMP-14A (A), RMP-14B (B)]</b> This differential pair output is a high speed ARINC 429 bus (100K bits/second nominal), that transmits data from the TCAS computer unit to the No. 2 Mode S Transponder. The labels on this bus are as follows: 273, 274, 275.
<b>RMP-14C</b>	<b>RA Display No. 1 Status Discrete Input (NO)</b> This input provides the functional status of RA Display No. 1. A ground on this pin indicates a valid display. If this discrete is not used by the RA display, connect to aircraft ground to prevent RA DISPLAY No. 1 fail message during self-test.
<b>RMP-14D, 14E</b>	<b>Selected Altitude 701/720 ARINC 429 Bus Input</b> Reserved for future use.
<b>RMP-14F, 14G</b>	<b>ARINC 429 XT Coordination No. 1 Input: [RMP-14F (A), RMP-14G (B)]</b> This differential pair input is a high speed ARINC 429 bus (100K bits/second nominal), that receives data from the No. 1 Mode S Transponder. The labels on this bus are as follows: 013, 015, 016, 203, 271, 272, 273, 274, 275, 276, 277, 350.
<b>RMP-14H, 14J</b>	<b>ARINC 429 XT Coordination No. 2 Input: [RMP-14H (A), RMP-14J (B)]</b> This differential pair input is a high speed ARINC 429 bus (100K bits/second nominal), that receives data from the No. 2 Mode S Transponder. The labels on this bus are as follows: 013, 015, 016, 203, 271, 272, 273, 274, 275, 276, 277, 350.
<b>RMP-14K</b>	<b>Spare Pin</b>



**SYSTEM DESCRIPTION AND INSTALLATION MANUAL**  
TCAS 3000 Traffic Alert and Collision Avoidance System

**Table 4-1. TCAS 3000 Computer Unit Loading/Gradient Specifications (cont)**

Connector Pin Designation	Functional Description
<b>RMP-15A thru RMP-H</b>	Reserved for future use.
<b>RMP-15J, 15K</b>	<b>ARINC 429 TX Coordination No. 1 Output: [RMP-15J (A), RMP-15K (B)]</b> This differential pair output is a high speed ARINC 429 bus (100K bits/second nominal), that transmits data from the TCAS computer unit to the No. 1 Mode S Transponder. The labels on this bus are as follows: 273, 274, 275.
<b>TCAS Computer Unit Right Bottom Plug (RBP)</b>	
<b>RBP-1A Thru RBP-1G</b>	Reserved for future use.
<b>RBP-1H</b>	<b>RA Data Word 270 Bit 18 Discrete Output</b> This discrete output provides RA information to the ARINC 573 flight recorder. The output goes to the "ground" state each time its associated bit within the advisory field of the RA output words changes from a "zero" condition to a "one" condition. The output remains in the "ground" state for as long as the associated RA bit remains non-zero. This output is read by the flight recorder as either a series or shunt output.
<b>RBP-1J</b>	<b>RA Data Word 270 Bit 19 Discrete Output</b> See RBP-1H.
<b>RBP-1K</b>	<b>RA Data Word 270 Bit 20 Discrete Output</b> See RBP-1H.
<b>RBP-2A Thru RBP-2G</b>	<b>Spare Pins</b>
<b>RBP-2H</b>	<b>RA Data Word 270 Bit 21 Discrete Output</b> See RBP-1H.
<b>RBP-2J</b>	<b>RA Data Word 270 Bit 22 Discrete Output</b> See RBP-1H.
<b>RBP-2K</b>	<b>RA Data Word 270 Bit 23 Discrete Output</b> See RBP-1H.
<b>RBP-3A, 3B</b>	<b>Radio Altimeter No. 2 ARINC 552/Analog Input: [RBP-3A (HI), RBP-3B (LO)]</b> See RMP-2H and -2J.
<b>RBP-3C</b>	<b>Radio Altimeter No. 2 Valid Discrete Input (PO)</b> See RMP-2H. Valid condition is greater than 18.5 V dc. Invalid is open.
<b>RBP-3D, 3E</b>	<b>Radio Altimeter No. 2 Input: [RBP-3D (A), RBP-3E (B)]</b> See RMP-13H. Also see RMP-2H.



**SYSTEM DESCRIPTION AND INSTALLATION MANUAL**  
 TCAS 3000 Traffic Alert and Collision Avoidance System

**Table 4-1. TCAS 3000 Computer Unit Loading/Gradient Specifications (cont)**

<b>Connector Pin Designation</b>	<b>Functional Description</b>
<b>RBP-3F, RBP-3G</b>	<b>Spare Pins</b>
<b>RBP-3H</b>	<b>RA Data Word 270 Bit 24 Discrete Output</b> See RBP-1H.
<b>RBP-3J</b>	<b>RA Data Word 270 Bit 25 Discrete Output</b> See RBP-1H.
<b>RBP-3K</b>	<b>RA Data Word 270 Bit 26 Discrete Output</b> See RBP-1H.
<b>RBP-4A Thru RBP-4F</b>	<b>Reserved Discrete Inputs</b> Reserved for future use.
<b>RBP-4G</b>	<b>RA Display Test Inhibit Program Pin</b> This program pin is used to determine if RA discrete monitoring will be inhibited during self-test. If this pin is connected to program common (ground), RA discrete self-test monitoring is inhibited. An open on this pin indicates RA discrettes monitoring during self-test.
<b>RBP-4H</b>	<b>RA Data Word 270 Bit 27 Discrete Output</b> See RBP-1H.
<b>RBP-4J</b>	<b>RA Data Word 270 Bit 28 Discrete Output</b> See RBP-1H.
<b>RBP-4K</b>	<b>RA Data Word 270 Bit 29 Discrete Output</b> See RBP-1H.



**SYSTEM DESCRIPTION AND INSTALLATION MANUAL**  
TCAS 3000 Traffic Alert and Collision Avoidance System

**Table 4-1. TCAS 3000 Computer Unit Loading/Gradient Specifications (cont)**

Connector Pin Designation	Functional Description																				
<p><b>RBP-5A</b></p>	<p><b>Advisory Inhibit Discrete Input No. 1 (NO)</b></p> <p>Four discrete inputs at RBP-5A, -5B, -5C, and -5D provide the capability for the TCAS computer unit to defer all advisory (TA), aural alert and visual alert outputs until another, higher priority announcement or alert is completed. An open at all four of these discrete inputs indicates normal advisory/alert operation. These discrete inputs become active by connection to program common (ground) at RBP-7K. No new TA information can be placed on the RA or RA/TA busses during a period of Advisory Inhibit. If an advisory condition, which occurred during a period of Advisory Inhibit, remains when the TCAS computer unit returns to normal operation, it is annunciated. The Advisory Inhibit inputs and their effect on the advisory/alert priority system are as follows:</p> <table border="1" data-bbox="337 743 1390 905"> <thead> <tr> <th><u>Discrete No.</u></th> <th><u>Pin No.</u></th> <th><u>Mode</u></th> <th><u>Priority</u></th> </tr> </thead> <tbody> <tr> <td>1</td> <td>RBP-5A</td> <td>Forced Standby</td> <td>1</td> </tr> <tr> <td>2</td> <td>RBP-5B</td> <td>Force TA Only (no voice/tone)</td> <td>2</td> </tr> <tr> <td>3</td> <td>RBP-5C</td> <td>Force TA Only (no voice/tone)</td> <td>2</td> </tr> <tr> <td>4</td> <td>RBP-5D</td> <td>Force TA Only (no voice/tone)</td> <td>2</td> </tr> </tbody> </table> <p>Discrete No. 1 (RBP-5A) has priority over No. 2 (RBP-5B), No. 3 (RBP-5C) and No. 4 (RBP-5D). Discrete No. 1 forces TCAS into STANDBY mode. Discretes No. 2, No. 3, and No. 4 force TCAS into TA mode with no voice or tone annunciations.</p>	<u>Discrete No.</u>	<u>Pin No.</u>	<u>Mode</u>	<u>Priority</u>	1	RBP-5A	Forced Standby	1	2	RBP-5B	Force TA Only (no voice/tone)	2	3	RBP-5C	Force TA Only (no voice/tone)	2	4	RBP-5D	Force TA Only (no voice/tone)	2
<u>Discrete No.</u>	<u>Pin No.</u>	<u>Mode</u>	<u>Priority</u>																		
1	RBP-5A	Forced Standby	1																		
2	RBP-5B	Force TA Only (no voice/tone)	2																		
3	RBP-5C	Force TA Only (no voice/tone)	2																		
4	RBP-5D	Force TA Only (no voice/tone)	2																		
<p><b>RBP-5B</b></p>	<p><b>Advisory Inhibit Discrete Input No. 2 (NO)</b> See RBP-5A.</p>																				
<p><b>RBP-5C</b></p>	<p><b>Advisory Inhibit Discrete Input No. 3 (NO)</b> See RBP-5A.</p>																				
<p><b>RBP-5D</b></p>	<p><b>Advisory Inhibit Discrete Input No. 4 (NO)</b> See RBP-5A.</p>																				
<p><b>RBP-5E</b></p>	<p><b>Increase Climb Inhibit Discrete Input No. 1 (NO)</b></p> <p>This input is a ground/open type discrete used to provide information to the TCAS CU whether to assume that the aircraft cannot achieve a climb rate of 2500 feet per minute (FPM). The climb inhibit discrete inputs are designed in pairs (No. 1 and No. 2 at RBP-5F, <b>or</b> No. 3 at RBP-5G and No. 4 at RBP-5H) but can be wired as a single input or in conjunction with other aircraft operations to achieve airframe customization of the climb inhibit feature. The 2500 FPM climb inhibit function is assumed whenever No. 1 and No. 2 are ground <b>or</b> No. 3 and No. 4 are ground.</p>																				
<p><b>RBP-5F</b></p>	<p><b>Increase Climb Inhibit Discrete Input No. 2 (NO)</b> See RBP-5E.</p>																				
<p><b>RBP-5G</b></p>	<p><b>Increase Climb Inhibit Discrete Input No. 3 (NO)</b> See RBP-5E.</p>																				
<p><b>RBP-5H</b></p>	<p><b>Increase Climb Inhibit Discrete Input No. 4 (NO)</b> See RBP-5E.</p>																				
<p><b>RBP-5J</b></p>	<p><b>Climb Inhibit Discrete Input No. 3 (NO)</b> See RMP-1J.</p>																				





**SYSTEM DESCRIPTION AND INSTALLATION MANUAL**  
TCAS 3000 Traffic Alert and Collision Avoidance System

**Table 4-1. TCAS 3000 Computer Unit Loading/Gradient Specifications (cont)**

Connector Pin Designation	Functional Description																																				
<b>RBP-5K</b>	<b>Climb Inhibit Discrete Input No. 4 (NO)</b> See RMP-1J.																																				
<b>RBP-6A</b>	<p><b>Airborne Data Loader Link A Discrete Input</b></p> <p>This discrete input, along with Data Loader Discrete Inputs No. 2, 3, and 4 (pins RBP-6B, RBP-6C, and RBP-6D, respectively), is a ground/open type discrete that specifies what type of data loader (ARINC 603 or ARINC 615) is attached. The TCAS computer unit has separate receiver busses and separate data loader enable discrete inputs to support simultaneous connections to an ADL and PDL. A ground on pin RBP-6A indicates that an airborne data loader is connected to the rear connector of the TCAS computer unit. A ground on pin J1-18, PDL Link A Discrete Input, indicates that a portable data loader is connected to the front connector of the TCAS computer unit. The data loader discrete inputs at RBP-6B, RBP-6C, and RBP-6D are also connected to the data loader discrete inputs on the front connector (pins J1-51, J1-52, and J1-53, respectively). Listed below is an active discrete (selected) indicated by a ground and an inactive discrete (not selected) indicated by an open.</p> <table border="1" data-bbox="430 926 1495 1163"> <thead> <tr> <th>RBP-6A</th> <th>J1-18</th> <th>J1-51/ RBP-6B</th> <th>J1-52/ RBP-6C</th> <th>J1-53/ RBP-6D</th> <th>Function</th> </tr> </thead> <tbody> <tr> <td>Ground</td> <td>Open</td> <td>Ground</td> <td>Open</td> <td>Open</td> <td>ARINC 615 ADL</td> </tr> <tr> <td>Ground</td> <td>Open</td> <td>Open</td> <td>Ground</td> <td>Open</td> <td>ARINC 603 ADL</td> </tr> <tr> <td>Open</td> <td>Ground</td> <td>Ground</td> <td>Open</td> <td>Open</td> <td>ARINC 615 PDL</td> </tr> <tr> <td>Open</td> <td>Ground</td> <td>Open</td> <td>Ground</td> <td>Open</td> <td>ARINC 603 PDL</td> </tr> <tr> <td>--</td> <td>--</td> <td>--</td> <td>--</td> <td>Ground</td> <td>SW Part Number is output</td> </tr> </tbody> </table>	RBP-6A	J1-18	J1-51/ RBP-6B	J1-52/ RBP-6C	J1-53/ RBP-6D	Function	Ground	Open	Ground	Open	Open	ARINC 615 ADL	Ground	Open	Open	Ground	Open	ARINC 603 ADL	Open	Ground	Ground	Open	Open	ARINC 615 PDL	Open	Ground	Open	Ground	Open	ARINC 603 PDL	--	--	--	--	Ground	SW Part Number is output
RBP-6A	J1-18	J1-51/ RBP-6B	J1-52/ RBP-6C	J1-53/ RBP-6D	Function																																
Ground	Open	Ground	Open	Open	ARINC 615 ADL																																
Ground	Open	Open	Ground	Open	ARINC 603 ADL																																
Open	Ground	Ground	Open	Open	ARINC 615 PDL																																
Open	Ground	Open	Ground	Open	ARINC 603 PDL																																
--	--	--	--	Ground	SW Part Number is output																																
<b>RBP-6B</b>	<b>Data Loader Discrete Input No. 2</b> See RBP-6A.																																				
<b>RBP-6C</b>	<b>Data Loader Discrete Input No. 3</b> See RBP-6A.																																				
<b>RBP-6D</b>	<b>Data Loader Discrete Input No. 4</b> See RBP-6A.																																				
<b>RBP-6E, 6F</b>	<b>ARINC 429 CFDS Output: [RBP-6E (A), RBP-6F (B)]</b> This differential pair output is a low speed ARINC 429 bus (12.5K bits/second nominal), that transmits data to an onboard maintenance computer or a central fault display system.																																				
<b>RBP-6G, 6H</b>	<b>ARINC 429 CFDS Input: [RBP-6G (A), RBP-6H (B)]</b> This differential pair input is a low speed ARINC 429 bus (12.5K bits/second nominal), that receives data from an onboard maintenance computer or a central fault display system.																																				
<b>RBP-6J</b>	<b>Single Mode S Program Pin</b> Ground this pin when the computer is connected to a single mode S transponder.																																				
<b>RBP-6K</b>	<b>Single Radio Altimeter Program Pin</b> Ground this pin when the computer is connected to a single radio altimeter.																																				





**SYSTEM DESCRIPTION AND INSTALLATION MANUAL**  
TCAS 3000 Traffic Alert and Collision Avoidance System

**Table 4-1. TCAS 3000 Computer Unit Loading/Gradient Specifications (cont)**

Connector Pin Designation	Functional Description																																																																						
<b>RBP-7A</b>	<p><b>Audio Level Program Pin No. 1 (NO)</b></p> <p>Two synthesized voice outputs with programmable output levels are provided by the TCAS computer unit. The output at RMP-2F and -2G supply high level (up to 4 Watts) audio signals to an 8 ohm speaker. The second output at RMP-3F and -3G supply low level (up to 80 milliwatts) audio signals to a 600 ohm audio distribution system. All aural traffic and resolution advisories can be annunciated over these outputs unless cancelled by a Cancel Discrete (RMP-3D).</p> <p>Listed below are the audio level program pin configurations and the resulting output levels:</p> <table border="1" data-bbox="332 724 1364 1081"> <thead> <tr> <th colspan="3">Program Pin</th> <th colspan="2">Low Level Output</th> <th colspan="2">High Level Output</th> </tr> <tr> <th>RBP-7A (MSB)</th> <th>RBP-7B</th> <th>RBP-7C (LSB)</th> <th>dBm</th> <th>mW</th> <th>dBm</th> <th>W</th> </tr> </thead> <tbody> <tr> <td>Open</td> <td>Open</td> <td>Open</td> <td>16</td> <td>40</td> <td>6</td> <td>4</td> </tr> <tr> <td>Open</td> <td>Open</td> <td>Ground</td> <td>13</td> <td>20</td> <td>3</td> <td>2</td> </tr> <tr> <td>Open</td> <td>Ground</td> <td>Open</td> <td>10</td> <td>10</td> <td>0</td> <td>1</td> </tr> <tr> <td>Open</td> <td>Ground</td> <td>Ground</td> <td>7</td> <td>5</td> <td>-3</td> <td>0.5</td> </tr> <tr> <td>Ground</td> <td>Open</td> <td>Open</td> <td>4</td> <td>2.5</td> <td>-6</td> <td>0.25</td> </tr> <tr> <td>Ground</td> <td>Open</td> <td>Ground</td> <td>1</td> <td>1.25</td> <td>-9</td> <td>0.125</td> </tr> <tr> <td>Ground</td> <td>Ground</td> <td>Open</td> <td>-2</td> <td>0.625</td> <td>-12</td> <td>0.0625</td> </tr> <tr> <td>Ground</td> <td>Ground</td> <td>Ground</td> <td>19</td> <td>80</td> <td>Not Used</td> <td>Not Used</td> </tr> </tbody> </table>	Program Pin			Low Level Output		High Level Output		RBP-7A (MSB)	RBP-7B	RBP-7C (LSB)	dBm	mW	dBm	W	Open	Open	Open	16	40	6	4	Open	Open	Ground	13	20	3	2	Open	Ground	Open	10	10	0	1	Open	Ground	Ground	7	5	-3	0.5	Ground	Open	Open	4	2.5	-6	0.25	Ground	Open	Ground	1	1.25	-9	0.125	Ground	Ground	Open	-2	0.625	-12	0.0625	Ground	Ground	Ground	19	80	Not Used	Not Used
Program Pin			Low Level Output		High Level Output																																																																		
RBP-7A (MSB)	RBP-7B	RBP-7C (LSB)	dBm	mW	dBm	W																																																																	
Open	Open	Open	16	40	6	4																																																																	
Open	Open	Ground	13	20	3	2																																																																	
Open	Ground	Open	10	10	0	1																																																																	
Open	Ground	Ground	7	5	-3	0.5																																																																	
Ground	Open	Open	4	2.5	-6	0.25																																																																	
Ground	Open	Ground	1	1.25	-9	0.125																																																																	
Ground	Ground	Open	-2	0.625	-12	0.0625																																																																	
Ground	Ground	Ground	19	80	Not Used	Not Used																																																																	
<b>RBP-7B</b>	<p><b>Audio Level Program Pin No. 2 (NO)</b></p> <p>See RBP-7A.</p>																																																																						
<b>RBP-7C</b>	<p><b>Audio Level Program Pin No. 3 (NO)</b></p> <p>See RBP-7A.</p>																																																																						
<b>RBP-7D</b>	<p><b>Audio Tone Enable Program Pin (NO)</b></p> <p>If this programming pin is connected to program common, (RBP-7K), all voice announcements are delayed by one second and are preceded by a tone. If pin is left open, no delays or tones occur.</p>																																																																						
<b>RBP-7E</b>	<p><b>Ground Display Mode Program Pin (NO)</b></p> <p>The TCAS computer unit monitors this programming pin to select the TCAS ground display mode while the aircraft is on the ground. If the aircraft is on the ground and this pin is connected to program common (RBP-7K), TCAS goes into standby mode. If this pin is left open and the aircraft is on the ground, TCAS displays traffic only. Aural and voice annunciations are inhibited while the aircraft is on the ground.</p> <p><b>NOTE:</b> TCAS does not display any traffic that it locates on the ground. TCAS aircraft has WOW and intruder aircraft reports the same altitude or a lower altitude.</p>																																																																						
<b>RBP-7F</b>	<p><b>Display All Traffic Program Pin (NO)</b></p> <p>The TCAS computer unit monitors this program pin to select either the all traffic display mode or the TA/RA only mode. If this pin is open, all traffic is displayed. If this pin is connected to program common (RBP-7K), the TCAS displays only TA/RA type intruders.</p>																																																																						



**SYSTEM DESCRIPTION AND INSTALLATION MANUAL**  
TCAS 3000 Traffic Alert and Collision Avoidance System

**Table 4-1. TCAS 3000 Computer Unit Loading/Gradient Specifications (cont)**

Connector Pin Designation	Functional Description																				
RBP-7G	<p><b>Cable Delay Signal Program Pin (NO)</b></p> <p>The cable delay program pins (RBP-7G, RBP-7H, and RBP-7J) convey to the TCAS computer unit the amount of delay differential between the top and bottom antenna cables. Pin RBP-7G determines whether a time delay is added to the top or bottom. If this pin is open, the time delay is added to the top. If this pin is ground (connected to program pin RBP-7K), the time delay is added to the bottom. The cable delay logic is given below. Program common for the cable delay program pins is RBP-7K.</p> <table border="1" data-bbox="431 653 1494 863"> <thead> <tr> <th>RBP-7H (MSB)</th> <th>RBP-7J (LSB)</th> <th>Differential Delay</th> <th>Adjustment</th> </tr> </thead> <tbody> <tr> <td>Open</td> <td>Open</td> <td>0-50 nsec</td> <td>No Change</td> </tr> <tr> <td>Open</td> <td>Ground</td> <td>51-150 nsec</td> <td>Add 100 nsec delay</td> </tr> <tr> <td>Ground</td> <td>Open</td> <td>151-250 nsec</td> <td>Add 200 nsec delay</td> </tr> <tr> <td>Ground</td> <td>Ground</td> <td>251-350 nsec</td> <td>Add 300 nsec delay</td> </tr> </tbody> </table>	RBP-7H (MSB)	RBP-7J (LSB)	Differential Delay	Adjustment	Open	Open	0-50 nsec	No Change	Open	Ground	51-150 nsec	Add 100 nsec delay	Ground	Open	151-250 nsec	Add 200 nsec delay	Ground	Ground	251-350 nsec	Add 300 nsec delay
RBP-7H (MSB)	RBP-7J (LSB)	Differential Delay	Adjustment																		
Open	Open	0-50 nsec	No Change																		
Open	Ground	51-150 nsec	Add 100 nsec delay																		
Ground	Open	151-250 nsec	Add 200 nsec delay																		
Ground	Ground	251-350 nsec	Add 300 nsec delay																		
RBP-7H	<p><b>Cable Delay MSB Program (NO)</b></p> <p>See RBP-7G.</p>																				
RBP-7J	<p><b>Cable Delay LSB Program Pin (NO)</b></p> <p>See RBP-7G.</p>																				
RBP-7K	<p><b>Program Common</b></p> <p>This is the ground source for use with program pins.</p>																				
RBP-8A Thru RBP-8D	<p><b>Reserved Program Pins</b></p>																				
RBP-8E	<p><b>Self-Test Test Inhibit Program Pin (NO)</b></p> <p>This program pin determines if self-test will be inhibited while airborne. If grounded, this pin inhibits self-test while airborne. If open, self-test is enabled while airborne.</p>																				
RBP-8F	<p><b>TA/RA Display Symbol Maximum 16 Program Pin (NO)</b></p> <p>The TCAS computer unit establishes the number of intruder symbols to be displayed on the TA display through the program pins RBP-8F, -8G, -8H, -8J, and -8K. This number can vary between 0 and 31, depending on the programming that is a summation of the selected pins. Connecting one of these pins to program common (RBP-7K) indicates the associated pin is not selected and that its value is not included in the summation. Leaving the pin open designates the associated pin is selected and its value is included in the summation. The encoded number is placed within the RTS data word (label 357) and sent to the display. The display should then limit the intruder symbols to this number.</p>																				
RBP-8G	<p><b>TA/RA Display Symbol Maximum 8 Program Pin (NO)</b></p> <p>See RBP-8F.</p>																				
RBP-8H	<p><b>TA/RA Display Symbol Maximum 4 Program Pin (NO)</b></p> <p>See RBP-8F.</p>																				



**SYSTEM DESCRIPTION AND INSTALLATION MANUAL**  
TCAS 3000 Traffic Alert and Collision Avoidance System

**Table 4–1. TCAS 3000 Computer Unit Loading/Gradient Specifications (cont)**

Connector Pin Designation	Functional Description
<b>RBP–8J</b>	<b>TA/RA Display Symbol Maximum 2 Program Pin (NO)</b> See RBP–8F.
<b>RBP–8K</b>	<b>TA/RA Display Symbol Maximum 1 Program Pin (NO)</b> See RBP–8F.
<b>RBP–9A Thru RBP–10K</b>	<b>Reserved Factory Test Pins</b> Leave these pins unconnected for aircraft installations.
<b>TCAS Computer Unit Left Top Plug (LTP)</b>	
<b>LTP–1</b>	<b>Top Antenna 0 Degree Port</b> J1 on the antenna is color–coded yellow. This antenna port is called the 0 degree port because it produces a transmission pattern in the forward quadrant of the aircraft. J1 is physically located toward the rear of the antenna and to the rear of the aircraft when antenna is properly installed. The TCAS computer unit checks the built–in dc to ground resistance of this antenna port. It must detect approximately 1000 ohms or TCAS fails its antenna test.
<b>LTP–2</b>	<b>Top Antenna 270 Degree Port</b> J2 on the antenna is color–coded black. This antenna port is called the 270 degree port because it produces a transmission pattern in the left wing quadrant of the aircraft. J2 is physically located toward the right wing of the aircraft when antenna is properly installed. The TCAS computer unit checks the built–in dc to ground resistance of this antenna port. It must detect approximately 8000 ohms or it reports antenna test failure.
<b>LTP–3</b>	<b>Top Antenna 180 Degree Port</b> J3 on the antenna is color–coded blue. This antenna port is called the 180 degree port because it produces a transmission pattern in the rear quadrant of the aircraft. J3 is physically located toward the front of the antenna and to the front of the aircraft when antenna is installed properly. The TCAS computer unit checks the built–in dc to ground resistance of this antenna port. It must detect approximately 4000 ohms or it reports antenna test failure.
<b>LTP–4</b>	<b>Top Antenna 90 Degree Port</b> J4 on the antenna is color–coded red. This antenna port is called the 90 degree port because it produces a transmission pattern in the right wing quadrant of the aircraft. J4 is physically located toward the left wing of the aircraft when antenna is properly installed. The TCAS computer unit checks the built–in dc to ground resistance of this antenna port. It must detect approximately 2000 ohms or it reports antenna test failure.
<b>TCAS Computer Unit Left Middle Plug (LMP)</b>	
<b>LMP–1</b>	<b>Bottom Antenna 0 Degree Port</b> J1 on the antenna is color–coded yellow. Same as top antenna 0 degree port (LTP–1). In addition, this port is used as the omnidirectional antenna connection. The TCAS computer unit determines that a bottom omnidirectional antenna is installed if it detects less than 500 Ohms (50 ohms typical) to ground on this pin and an open circuit (>13K Ohms) at LMP– 2, –3, and –4 or a dc short (<500 Ohms) if unused ports are terminated at back of mounting tray.



**SYSTEM DESCRIPTION AND INSTALLATION MANUAL**  
TCAS 3000 Traffic Alert and Collision Avoidance System

**Table 4-1. TCAS 3000 Computer Unit Loading/Gradient Specifications (cont)**

<b>Connector Pin Designation</b>	<b>Functional Description</b>
<b>LMP-2</b>	<p><b>Bottom Antenna 90 Degree Port</b></p> <p>J2 on the antenna is color-coded black. This antenna port is called the 90 degree port because it produces a transmission pattern in the right wing quadrant of the aircraft. J2 is physically located toward the left wing of the aircraft when antenna is properly installed. The TCAS computer unit checks the built in dc to ground resistance of this antenna port. It must detect approximately 8000 ohms or it reports antenna test failure.</p>
<b>LMP-3</b>	<p><b>Bottom Antenna 180 Degree Port</b></p> <p>J3 on the antenna is color-coded blue. Same as top antenna 180 degree port (LTP-3).</p>
<b>LMP-4</b>	<p><b>Bottom Antenna 270 Degree Port</b></p> <p>J4 on the antenna is color-coded red. This antenna port is called the 270 degree port because it produces a transmission pattern in the left wing quadrant of the aircraft. J4 is physically located toward the right wing of the aircraft when properly installed. The TCAS computer unit checks the built in dc to ground resistance of this antenna port. It must detect approximately 2000 ohms or it reports antenna test failure.</p>
<b>TCAS Computer Unit Left Bottom Plug (LBP)</b>	
<b>LBP-1</b>	<p><b>115 V ac Power Input (H)</b></p> <p>This pin along with the 115 V ac Power Input (C) line (pin LBP-7) provides the 115 V ac power requirements for the TCAS computer unit.</p> <p><b>NOTE:</b> The TCAS computer unit operates with either 115 V ac, 400 Hz, or 28 V dc input power. If 115 V ac is used, the power should be connected through a 5 Amp circuit breaker, and the pins for the 28 V dc input should be left unconnected.</p>
<b>LBP-2</b>	<b>Spare Pin</b>
<b>LBP-3</b>	<p><b>+28 V dc Power Return (LO)</b></p> <p>See LBP-10.</p>
<b>LBP-4</b>	<b>Spare Pin</b>
<b>LBP-5</b>	<p><b>Fan 115 V ac Power Output (H)</b></p> <p>This pin along with the Fan 115 V ac Output Power (C) line (pin LBP-9) provides 115 V ac power for an external fan.</p>
<b>LBP-6</b>	<b>Spare Pin</b>
<b>LBP-7</b>	<p><b>115 V ac Power Input (C)</b></p> <p>See LBP-1.</p>
<b>LBP-8</b>	<p><b>Signal Ground</b></p> <p>Connect to Aircraft Signal Ground.</p>
<b>LBP-9</b>	<p><b>Fan 115 V ac Power Output (C)</b></p> <p>See LBP-5.</p>



**SYSTEM DESCRIPTION AND INSTALLATION MANUAL**  
TCAS 3000 Traffic Alert and Collision Avoidance System

**Table 4–1. TCAS 3000 Computer Unit Loading/Gradient Specifications (cont)**

Connector Pin Designation	Functional Description
<b>LBP–10</b>	<p><b>+28 V dc Power Input (HI)</b></p> <p>This pin along with the TCAS computer unit 28 V dc Power Return line (LBP–3) provide the +28 V dc power requirements for the TCAS computer unit.</p> <p><b>NOTE:</b> This TCAS computer unit operates with either 115 V ac, 400 Hz, or 28 V dc input power. If +28 V dc is used, the power should be connected through a 10 Amp circuit breaker, and the pins for the 115 V ac input should be left unconnected.</p>
<b>LBP–11</b>	<p><b>Chassis Ground</b></p> <p>Connect to aircraft frame.</p>
<b>LBP–12</b>	<p><b>Mutual Suppression Pulse Bus Input</b></p> <p>The TCAS computer unit joins the mutual suppression bus daisy chained through TCAS and other RF transmitting equipment on board the aircraft. TCAS receives suppression pulses from other LRUs on this bus, which is used to suppress the TCAS receivers during such transmissions. This prevents the TCAS computer unit from interpreting these transmissions as valid replies from an intruder aircraft. When not suppressed, the TCAS computer unit transmits its own suppression pulses on the same bus in order to suppress the receivers in other L–band systems on the aircraft. This pin is designated as the input. Pin LBP–13 is directly connected to this pin internally and functions as the output.</p> <p>L–Band suppression coax must be RG–142, RG400, or equivalent coaxial cable which meets the operational characteristics required by ARINC 735. LBP–12 and LBP–13 are connected internally. Connection to only one pin is required.</p>
<b>LBP–13</b>	<p><b>Mutual Suppression Pulse Bus Output</b></p> <p>See LBP–12.</p>
<p><b>The interface descriptions that follow are for the 53–pin Data Loader connector J1 mounted on the front panel of the TCAS computer unit. These descriptions are used to make up the cable that is used to interface between the TCAS computer unit and an ARINC 615 Portable Data Loader (PDL), a RS–232 PC Serial Port, a RS–422 Flight Data Recorder, or an ARINC 429 Maintenance Display.</b></p>	
<b>J1–1, 2</b>	<p><b>ARINC 429 PDL Bus Input: [J1–1 (A), J1–2 (B)]</b></p> <p>This differential pair input is a high–speed ARINC 429 bus (100K bits/second nominal) that is used to input data from the data loader to the TCAS computer unit. The standards for this interface are defined in ARINC 615 Airborne Computer High Speed Data Loader.</p> <p>These pins should be connected to pins 1 and 2 of the PDL cable interface.</p>
<b>J1–3, J1–4</b>	<p><b>Spare Pins</b></p>
<b>J1–5</b>	<p><b>Output Bus Shields</b></p> <p>The shields from the output bus (J1–8, 9) should be connected to this pin.</p>
<b>J1–6, J1–7</b>	<p><b>ARINC 615 Data Loader Ethernet: [J1–6 TD+, J1–7 TD–]</b></p>



**SYSTEM DESCRIPTION AND INSTALLATION MANUAL**  
TCAS 3000 Traffic Alert and Collision Avoidance System

**Table 4–1. TCAS 3000 Computer Unit Loading/Gradient Specifications (cont)**

Connector Pin Designation	Functional Description
J1–8, 9	<p><b>ARINC 429 Data Loader/PDL Recorder Bus Output: [J1–8 (A), J1–9 (B)]</b></p> <p>This differential pair output is a high–speed ARINC 429 bus (100K bits/second nominal) that is used to output data from the TCAS computer unit to the data loader. The standards for this interface are defined in ARINC 615 Airborne Computer High Speed Data Loader.</p> <p>These pins should be connected to pins 8 and 9 of the PDL cable interface.</p>
J1–10 thru J1–15	<p><b>ARINC 615 Data Loader</b></p> <p>Reserved</p>
J1–16	<p><b>Input Bus Shields</b></p> <p>The shields from the input bus (J1–1, 2) should be connected to this pin.</p>
J1–17	<p><b>Spare Pin</b></p>
J1–18	<p><b>PDL Link A Discrete Input</b></p> <p>This is a ground/open discrete from an portable ARINC 615 or ARINC 603 data loader which indicates, to the TCAS computer unit, that a data loader is connected. A ground indicates a data loader is connected.</p>
J1–19	<p><b>PDL Link B Common</b></p> <p>Connect this pin to pin 19 of the PDL cable interface.</p>
J1–20, 22	<p><b>115 V ac Power Output: [J1–20 (H), J1–22 (C)]</b></p> <p>These power output pins provide the 115 V ac operating power for the data loader. The 115 V ac (H) and 115 V ac (C) interconnect wires should be shielded or twisted and shielded with an insulating jacket over the shield. The shield should be connected to chassis ground (J1–21).</p>
J1–21	<p><b>Chassis Ground</b></p> <p>Connect 115 V ac power shields to this pin.</p>
J1–23	<p><b>ARINC 615 Data Loader Ethernet Input (RD+)</b></p>
J1–24 thru J1–32	<p><b>Reserved</b></p>
J1–33,34	<p><b>ARINC 429 TA/RA Display No. 1 Output: [J1–33 (A), J1–34 (B)]</b></p> <p>This bus can be used to connect to a maintenance display. These pins are also connected to the ARINC 600 connector on the rear of the unit (RMP–7C and –7D).</p>
J1–35, J1–36	<p><b>Reserved</b></p>



**SYSTEM DESCRIPTION AND INSTALLATION MANUAL**  
TCAS 3000 Traffic Alert and Collision Avoidance System

**Table 4-1. TCAS 3000 Computer Unit Loading/Gradient Specifications (cont)**

<b>Connector Pin Designation</b>	<b>Functional Description</b>
<b>J1-37, 38</b>	<b>28 V dc Power Output: [J1-37 (HI), J1-38 (LO)]</b> These power output pins provide the 28 V dc operating power for the data loader. These pins are used only if the data loader operates from a +28 V dc source.
<b>J1-39</b>	<b>Reserved</b>
<b>J1-40</b>	<b>RS-232 Data Input</b> This pin is used to receive RS-232 data from a portable maintenance terminal.
<b>J1-41</b>	<b>RS-232 Data Output</b> This pin is used to transmit RS-232 data to a portable maintenance terminal.
<b>J1-42 Thru J1-47</b>	<b>Spare Pins</b>
<b>J1-48, J1-49</b>	<b>Logic Common</b> Common lines for the RS-232 Data Input/Output lines. These two pins are tied together in the TCAS computer unit.
<b>J1-50</b>	<b>Reserved Pin</b>
<b>J1-51</b>	<b>Data Loader Link No. 2 Discrete Input</b> Pins J1-51 and J1-52 are ground/open discrettes from a portable data loader, which are used to specify what type of data loader (ARINC 603 or ARINC 615) is connected to the TCAS computer unit. These two pins are also connected to the ARINC 600 connector on the rear of the unit (RBP-6B and -6C respectively).
<b>J1-52</b>	<b>Data Loader Link No. 3 Discrete Input</b> See J1-51.
<b>J1-53</b>	<b>Data Loader Link No. 4 Discrete Input</b> This is a ground/open discrete from a Portable Data Loader (PDL) that is used to transmit the software part number on the Data Loader output bus when grounded, The landing gear indicates extended, and the air/ground indicates ground. This pin is also connected to the ARINC 600 connector on the rear of the unit (RBP-6D).





**SYSTEM DESCRIPTION AND INSTALLATION MANUAL**  
TCAS 3000 Traffic Alert and Collision Avoidance System

**Table 4–2. ACSS Dual Mode S Control Panel Interface Descriptions**

Connector Pin Designation	Functional Description
J1–1,2	<b>PANEL AND DISPLAY LIGHTING INPUT: (J1–1 LOW, J1–2 HIGH)</b> 5 V ac, 3.0 Watts maximum lighting input for front panel and display lighting. Lighting is provided by incandescent lamps.
J1/J2–3,4	<b>115 V ac INPUT POWER: (J1/J2–3 HIGH, J1/J2–4 LOW)</b> The control panel is powered from a 115 V ac power bus. Two identical but isolated power supplies provide the power requirements to each individual electronic module which independently control, transponder 1 and 2. Maximum power is 2.0 Watts.
J1/J2–5	<b>ANTENNA TRANSFER DISCRETE OUTPUT: (J1/J2–5)</b> These discrete outputs are used to provide the ability to switch a RF relay for dual transponder installations that have only one set of antennas. The outputs from J1 and J2 are linked to the XPDR 1–2 switch. The output is OPEN when the transponder is in standby (inactive) mode, and GROUND when the transponder is in an active operational mode.
J1/J2–6	<b>DC GROUND INPUT: (J1/J2–6)</b> Reference for all discrete inputs/outputs. Tied to aircraft dc ground.
J1/J2–7	<b>STANDBY/ON OUTPUT: (J1/J2–7)</b> These discrete outputs (STANDBY/ON) will mimic the XPDR switch position placing one transponder in Standby and the other in the ON (active) mode. Both transponders will never be in the ON mode simultaneously. This output is low (GROUND) when in Standby mode and OPEN when in the ON mode. This output can sink 100 mA maximum. Connect pin to transponder STANDBY / ON Discrete Input.
J1/J2–8	<b>CHASSIS GROUND INPUT: (J1/J2–8)</b> Tied to airframe. Also used to connect ARINC 429 cable shields to the chassis.
J1–9	<b>FUNCTIONAL TEST INPUT: (J1–9)</b> Functional test can also be initiated using this discrete input. When J1–9 is grounded, a functional test similar to pushing the TCAS TEST button on the front panel is initiated.
J1–10	<b>WARNING AND CAUTION OUTPUT: (J1–10)</b> This discrete output provides a low signal to a remote master warning system when the control panel receives a Monitor Lamp fault indication from the active transponder. Otherwise, it provides 7 to 30 V dc or a resistance of >100 K Ohms to ground. This output can sink 20 mA maximum.
J1/J2–12	<b>XPDR FAIL #2 INPUT: (J1/J2–12)</b> The control panel XPDR FAIL annunciator is controlled by this input. When the transponder is operating normally this input remains grounded. Otherwise, the transponder opens this input to indicate a transponder failure. The control panel then turns the annunciator ON to alert the user of a transponder malfunction. The transponder fail annunciator turns on only when the failed transponder is selected by the XPDR 1–2 switch. Connect this pin to the transponder XPDR FAIL #2 Discrete Output.





**SYSTEM DESCRIPTION AND INSTALLATION MANUAL**  
TCAS 3000 Traffic Alert and Collision Avoidance System

**Table 4-2. ACSS Dual Mode S Control Panel Interface Descriptions (cont)**

<b>Connector Pin Designation</b>	<b>Functional Description</b>
<b>J1/J2-16</b>	<p><b>AIR DATA SOURCE OUTPUT: (J1/J2-16)</b></p> <p>Ground/Open output that is dependent on the front panel ALT RPTG and XPDR switch positions. This discrete output is enabled when altitude reporting is selected in the ON mode. When altitude reporting is selected OFF, the J1/J2-16 output remains in the OPEN state.</p> <p>This discrete output is connected to the transponder AIR DATA SOURCE SELECT Discrete Input.</p>
<b>J1-18</b>	<p><b>MONITOR LAMP POWER INPUT: (J1-18)</b></p> <p>This input is used as the input power source for the XPDR FAIL annunciator on the front panel of the control panel. The input supply voltage is a dimmable 26 V dc at 200 mA maximum.</p>
<b>J1/J2-20</b>	<p><b>XPDR FAIL #1 DISCRETE INPUT: (J1/J2-20)</b></p> <p>This pin is tied directly to control panel pin J1/J2-12. See pin 12.</p>
<b>J1-21</b>	<p><b>LAMP TEST INPUT: (J1-21)</b></p> <p>To initiate a lamp test, pin J1-21 must be grounded through a remote test switch. All segments in the control panel LCD display are ON for as long as this input is grounded. ARINC 429 labels are not affected by the activation of a lamp test mode.</p>
<b>J1/J2-22, 23</b>	<p><b>ARINC 429 OUTPUTS: (J1/J2-22, 23)</b></p> <p>Communication between the control panel and the transponder is done over a two wire low speed, odd parity, ARINC 429 compatible bus. Selected ATC code, operating mode, and system parameters are communicated to the transponder over these lines. Transmission of labels 013, 015, 016, and 031 is done every 150 milliseconds.</p> <p>Connect these pins to one of the two transponder ARINC 429 CONTROL DATA Input Ports.</p>



**SYSTEM DESCRIPTION AND INSTALLATION MANUAL**  
TCAS 3000 Traffic Alert and Collision Avoidance System

**Table 4-3. ACSS ATRCBS-Mode S Control Panel Interface Descriptions**

<b>Connector Pin Designation</b>	<b>Functional Description</b>
<b>J1-1, 2</b>	<b>PANEL AND DISPLAY LIGHTING INPUT: (J1-1 LOW, J1-2 HIGH)</b> 5 V ac, 3.0 Watts maximum lighting input for front panel and display lighting. Lighting is provided by incandescent lamps.
<b>J1-3, 4</b>	<b>115 V ac INPUT POWER: (J1-3 HIGH, J1-4 LOW)</b> The control panel is powered from a 115 V ac power bus. A single power supply provides the power requirements for the control panel. Maximum power is 2.0 Watts.
<b>J1-5</b>	<b>ANTENNA TRANSFER DISCRETE OUTPUT: (J1-5)</b> This discrete output is used to provide the ability to switch a RF relay for dual transponder installations that have only one set of antennas. The output is OPEN when the transponder is in standby (inactive) mode, and GROUND when the transponder is in an active operational mode.
<b>J1-6</b>	<b>DC GROUND INPUT: (J1-6)</b> Reference for all discrete inputs/outputs. Tied to aircraft dc ground.
<b>J1-7</b>	<b>STANDBY/ON OUTPUT: (J1-7)</b> This discrete output (STANDBY/ON) will mimic the XPDR switch position placing one transponder in Standby and the other in the ON (active) mode. Both transponders will never be in the ON mode simultaneously. This output is low (GROUND) when in Standby mode and OPEN when in the ON mode. This output can sink 100 mA maximum. Connect this pin to transponder STANDBY/ON Discrete Input.
<b>J1-8</b>	<b>CHASSIS GROUND INPUT: (J1-8)</b> Tied to airframe. Also used to connect ARINC 429 cable shields to the chassis.
<b>J1-9</b>	<b>FUNCTIONAL TEST INPUT: (J1-9)</b> Functional test can also be initiated using this discrete input. When J1-9 is grounded through a remote test switch, a functional test similar to pushing the TCAS TEST button on the front panel is initiated.
<b>J1-10</b>	<b>WARNING AND CAUTION OUTPUT: (J1-10)</b> This discrete output provides a low signal to a remote master warning system when the control panel receives a Monitor Lamp fault indication from the active transponder. Otherwise it provides 7 to 30 V dc or a resistance of >100 K ohms to ground. This output can sink 20 mA maximum.
<b>J1-12</b>	<b>XPDR FAIL #2 INPUT: (J1-12)</b> The control panel XPDR FAIL annunciator is controlled by this input. When the transponder is operating normally this input remains grounded. Otherwise, the transponder opens this input to indicate a transponder failure. The control panel then turns the annunciator ON to alert the user of a transponder malfunction. The transponder fail annunciator turns on only when the failed transponder is selected by the control panel Mode switch. Connect this pin to the transponder XPDR FAIL #2 Discrete Output.



**SYSTEM DESCRIPTION AND INSTALLATION MANUAL**  
TCAS 3000 Traffic Alert and Collision Avoidance System

**Table 4-3. ACSS ATRBS-Mode S Control Panel Interface Descriptions (cont)**

Connector Pin Designation	Functional Description
<b>J1-16</b>	<p><b>AIR DATA SOURCE OUTPUT: (J1-16)</b></p> <p>Ground/Open output dependent on the front panel ALT RPTG switch position. This discrete output is enabled (Grounded) when altitude reporting is selected in the ON mode. When altitude reporting is selected OFF, the J1-16 output is in an Open state.</p> <p>This discrete output is connected to the transponder AIR DATA SOURCE SELECT Discrete Input.</p>
<b>J1-18</b>	<p><b>MONITOR LAMP POWER INPUT: (J1-18)</b></p> <p>This input is used as the input power source for the XPDR FAIL annunciator on the front panel of the control panel. The input supply voltage is a dimmable 26 V dc at 200 mA maximum.</p>
<b>J1-20</b>	<p><b>XPDR FAIL #1 DISCRETE INPUT: (J1-20)</b></p> <p>This pin is tied directly to control panel pin J1-12. See pin 12.</p>
<b>J1-21</b>	<p><b>LAMP TEST INPUT: (J1-21)</b></p> <p>To initiate a lamp test, pin J1-21 must be grounded through a remote test switch. All segments in the control panel LCD display will be ON for as long as this input is grounded. ARINC 429 labels are not affected by the activation of a lamp test mode.</p>
<b>J1-22, 23</b>	<p><b>ARINC 429 OUTPUTS: (J1/J2-22, 23)</b></p> <p>Communication between the control panel and the Mode S transponder is done over a two wire low speed, odd parity, ARINC 429 compatible bus. Selected ATC code, operating mode, and system parameters are communicated to the transponder over these lines. Transmission of labels 013, 015, 016, and 031 is done every 150 milliseconds.</p> <p>Connect these pins to one of the two transponder ARINC 429 CONTROL DATA Input Ports.</p>
<b>CONNECTOR J2 INTERFACE DESCRIPTIONS</b>	
<b>J2-L</b>	<p><b>ALTITUDE NO.1 OUTPUT: (J2-L)</b></p> <p>This discrete output along with pin J2-N and J2-R outputs are used in conjunction with the ALT RPTG switch on the control panel to enable one of two sources of altitude reporting data to be selected. These outputs are used only if two altitude sources are used.</p> <p>Connect this pin to Altitude Digitizer No.1 COMMON output.</p>
<b>J2-N</b>	<p><b>ALTITUDE NO.2 OUTPUT: (J2-N)</b></p> <p>See pin J2-L. Connect pin J2-N to Altitude Digitizer No.2 COMMON output.</p>
<b>J2-R</b>	<p><b>ALTITUDE COMMON: (J2-R)</b></p> <p>See pin J2-L. Connect pin J2-R to the ATRBS transponder Altitude Common input.</p>
<b>J2-T</b>	<p><b>TRANSPONDER NO. 2 ON OUTPUT: (J2-T)</b></p> <p>This discrete output puts the ATRBS transponder in either a standby or active mode. It is used in conjunction with the Mode switch on the front panel of the control panel. The output uses Ground/Open logic, where an Open specifies Standby and a Ground specifies an Active mode (ATC On).</p> <p>Connect this pin to the ATRBS transponder ON input.</p>



**SYSTEM DESCRIPTION AND INSTALLATION MANUAL**  
TCAS 3000 Traffic Alert and Collision Avoidance System

**Table 4-3. ACSS ATCRBS-Mode S Control Panel Interface Descriptions (cont)**

Connector Pin Designation	Functional Description
J2-X, Y, Z, a, b, c, d, e, f, g, h and i	<p><b>MODE A REPLY CODE PULSE OUTPUTS:</b></p> <p>These 4096 Reply Code outputs are manually set by the reply code knobs on the front of the control panel and are used for replies to Mode A interrogations.</p> <p>These pins should be connected to the ATCRBS transponder Mode A interface.</p>
J2-j	<p><b>IDENT OUTPUT: (J2-j)</b></p> <p>This discrete output provides a low signal (Ground) to an ATCRBS transponder whenever the IDENT button is pushed on the Control Panel.</p> <p>Connect this pin to the ATCRBS transponder Ident (SPI) discrete input.</p>
J2-m	<p><b>ATC FAIL INPUT: (J2-m)</b></p> <p>This discrete input is used to control the control panel XPDR FAIL annunciator when an ATCRBS transponder is being used. When the transponder is operating normally, this input is open (resistance greater than 100K ohms to ground). If a transponder failure has occurred, this input is greater than 4.0 V dc at 100 mA of current.</p> <p>Connect this pin to the transponder ATC FAIL output.</p>
J2-r	<p><b>ALTITUDE REPORTING ON OUTPUT: (J2-r)</b></p> <p>Ground/Open output that is dependent on the front panel ALT RPTG switch position. This discrete output is enabled when altitude reporting is selected in the ON mode. When altitude reporting is selected OFF, the output at pin J2-r will be in the OPEN state.</p> <p>This discrete output is connected to the transponder ALTITUDE REPORTING ON/OFF Discrete Input.</p>
J2-s	<p><b>TEST OUTPUT: (J2-s)</b></p> <p>This discrete output provides a low signal (Ground) to an ATCRBS transponder whenever the TCAS TEST button is pushed on the Control Panel. The control panel Mode switch must be in the ATC position to initiate an ATCRBS transponder test.</p>
J2-t	<p><b>TRANSPONDER NO. 1 ON: (J2-t)</b></p> <p>This discrete output puts a Mode S transponder in either a standby or active mode. It is used in conjunction with the Mode switch on the front panel of the Control Panel. The output uses Ground/Open logic where an Open specifies Standby and a Ground specifies an Active mode (ON, TA, or TA/RA).</p> <p>This pin is not used with ACSS Mode S Transponders.</p>



**SYSTEM DESCRIPTION AND INSTALLATION MANUAL**  
TCAS 3000 Traffic Alert and Collision Avoidance System

**Table 4-4. Gables Control Panel Interface Descriptions**

Connector Pin Designation	Functional Description
J1-1,2	<b>PANEL AND DISPLAY LIGHTING INPUT: (J1-1 HIGH, J1-2 LOW)</b> 5 V ac, 2.3 Amp maximum lighting input for front panel and display lighting. Lighting is provided by incandescent lamps.
J1/J2-3, 4	<b>+28 V dc INPUT POWER: (J1/J2-3 HIGH, J1/J2-4 LOW)</b> The control panel is powered from a +28 V dc power bus. Two identical but isolated power supplies provide the power requirements to each individual electronic module that independently control transponder 1 and 2. Maximum current is 2.5 Amps dc.
J1/J2-5	<b>ANTENNA TRANSFER DISCRETE OUTPUT: (J1/J2-5)</b> This discrete output is used to provide the ability to switch a RF relay for dual transponder installations that have only one set of antennas. These outputs from J1 and J2 are linked to the XPNDR 1-2 switch. The output is OPEN when the transponder is in standby (inactive) mode, and GROUND when the transponder is in an active operational mode.
J1/J2-6	<b>DC GROUND INPUT: (J1/J2-6)</b> Reference for all discrete inputs/outputs. Tied to aircraft dc ground.
J1/J2-7	<b>STANDBY/ON OUTPUT: (J1/J2-7)</b> These discrete outputs (STANDBY/ON) will mimic the XPNDR switch position placing one transponder in Standby and the other in the ON (active) mode. Both transponders will never be in the ON mode simultaneously. This output is (GROUND) when in Standby mode and OPEN when in the ON mode. This output can sink 100 mA maximum. Connect pin to transponder STANDBY / ON Discrete Input.
J1/J2-8	<b>CHASSIS GROUND INPUT: (J1/J2-8)</b> Tied to airframe. Also used to connect ARINC 429 cable shields to the chassis.
J1/J2-9	<b>FUNCTIONAL TEST INPUT: (J1/J2-9)</b> Functional test can also be initiated using this input discrete. When J1/J2-9 is grounded, a functional test similar to pushing the TEST button on the front panel is done.
J1/J2-10	<b>WARNING AND CAUTION OUTPUT: (J1/J2-10)</b> This discrete output provides a low signal to a remote master warning system when the control panel receives a Monitor Lamp fault indication from the active transponder. Otherwise it provides 7 to 30 V dc or a resistance of >100K ohms to ground. This output can sink 20 mA maximum.
J1/J2-12	<b>TRANSPONDER FAIL #2 INPUT: (J1/J2-12)</b> The G7130-XX ATC/TCAS control panel transponder fail annunciator is controlled by this input. When the transponder is operating normally this input remains grounded. Otherwise, the transponder opens this input to indicate a transponder failure. The control panel turns the annunciator ON to alert the user of a transponder malfunction. The transponder fail annunciator turns on only when the failed transponder is selected by the XPNDR 1-2 switch. Connect this pin to the transponder XPDR FAIL #2 Discrete Output.



**SYSTEM DESCRIPTION AND INSTALLATION MANUAL**  
TCAS 3000 Traffic Alert and Collision Avoidance System

**Table 4-4. Gables Control Panel Interface Descriptions (cont)**

<b>Connector Pin Designation</b>	<b>Functional Description</b>
<b>J1/J2-13</b>	<p><b>IDENT INPUT: (J1/J2-13)</b></p> <p>The IDENT discrete input provides another means of activating the IDENT function. This input allows the control panel to interface with an external IDENT switch located in the cockpit. When the input is grounded, the IDENT function is activated; otherwise it should remain open.</p>
<b>J1/J2-14</b>	<p><b>TRANSPONDER FAIL LOGIC DISCRETE INPUT: (TDR-94D ONLY) (J1/J2-14)</b></p> <p>This input allows the control panel to use 28 volt logic from a Collins TDR-94D transponder to control the transponder fail annunciator. This input should not be used unless a Collins TDR-94D transponder is used with this control panel.</p>
<b>J1/J2-15</b>	<p><b>AIR/GROUND SW DISCRETE OUTPUT: (J1/J2-15)</b></p> <p>This output is directly connected to the AIR/GND discrete input (J1/J2-24). This output can be routed directly to the transponder to disable it (Standby), and terminate ATC code replies. J1 discrete logic operates independently from J2.</p>
<b>J1/J2-16</b>	<p><b>AIR DATA SOURCE OUTPUT: (J1/J2-16)</b></p> <p>Ground/Open output that is dependent on the front panel ALT RPTG and XPNDR switch positions. This discrete output is enabled when altitude reporting is selected in the ON mode. When altitude reporting is selected OFF, the J1/J2-16 output remains in the OPEN state.</p> <p>This discrete output is connected to the transponder AIR DATA SOURCE SELECT Discrete Input.</p>
<b>J1/J2-18</b>	<p><b>MONITOR LAMP POWER INPUT: (J1/J2-18)</b></p> <p>These inputs are used as the input power source for the transponder fail annunciator on the front panel of the control panel. The input supply voltage is a dimmable 26 V dc at 200 mA maximum.</p>
<b>J1/J2-20</b>	<p><b>TRANSPONDER STRAPPING CONFIGURATION: (J1/J2-20)</b></p> <p>This discrete input programs the control panel to operate, and be able to properly interface to one of two types of transponder configurations. If this input is left OPEN then the control panel operates in accordance with ACSS transponder specifications. If the input is GROUNDED, it is programmed to operate in accordance with Collins transponder specifications.</p>
<b>J1/J2-21</b>	<p><b>LAMP TEST INPUT: (J1/J2-21)</b></p> <p>To initiate a lamp test, J1 or J2 pin 21 must be grounded through an external switch. All segments and annunciators in the control panel LCD (except RPLY and decimal points) are ON for as long as this input is grounded. ARINC 429 labels are not affected by the activation of a lamp test mode.</p>



**SYSTEM DESCRIPTION AND INSTALLATION MANUAL**  
TCAS 3000 Traffic Alert and Collision Avoidance System

**Table 4-4. Gables Control Panel Interface Descriptions (cont)**

<b>Connector Pin Designation</b>	<b>Functional Description</b>
<b>J1/J2-22, 23</b>	<b>ARINC 429 OUTPUTS: (J1/J2-22,23)</b> Communication between the control panel and the transponder is done over a two wire low speed, odd parity, ARINC 429 compatible bus. Selected ATC code, operating mode, and system parameters are communicated to the transponder over these lines. Transmission of labels 013, 015, 016, and 031 is done every 150 milliseconds. Connect these pins to one of the two transponder ARINC 429 CONTROL DATA Input Ports.
<b>J1/J2-24</b>	<b>AIR/GROUND INPUT DISCRETE: (J1/J2-24)</b> The control panel accepts input from two independent Air/Ground (WOW) switches for applications that require automatic disabling of the transponder upon landing. This input is wired directly to the AIR/GROUND SW Discrete Output (J1/J2-15).



**SYSTEM DESCRIPTION AND INSTALLATION MANUAL**  
TCAS 3000 Traffic Alert and Collision Avoidance System

**Table 4-5. 41-Pin VSI/TRA Interface Descriptions**

<b>Connector Pin Designation</b>	<b>Functional Description</b>
<b>J1-1</b>	<b>VERTICAL SPEED +DC REFERENCE INPUT:</b> Pins 1,2, and 3 are inputs to the VSI/TRA from an ARINC 575 air data computer indicating vertical speed. Pin 1 is a +12 V dc regulated reference voltage from the ADC. Pin 3 is a -12 V dc regulated reference voltage from the ADC. Pin 2 receives a +10 to -10 V dc rate signal from the ADC. Also see pins 31, 32, and 33.
<b>J1-2</b>	<b>VERTICAL SPEED DC RATE INPUT:</b> See pin 1.
<b>J1-3</b>	<b>VERTICAL SPEED -DC REFERENCE INPUT:</b> See pin 1.
<b>J1-4, 6</b>	<b>ARINC 565 VERTICAL SPEED AC INPUT: (J1-4 HIGH, J1-6 LOW)</b> Pins 4, 5, 6, and 16 are inputs to the VSI/TRA from an ARINC 565 air data computer or IRS. A 26 V ac, 400 Hz reference signal is received on pin 5, (HI) and pin 16, (LO). Pin 4, (HI) and pin 6, (LO) provides an amplitude modulated 400 Hz signal with a maximum voltage of $\pm 6.25$ volts. The RMS value of this signal is used by the VSI/TRA to compute and display the vertical rate. The phase of this signal is compared with the reference signal to determine if the rate is positive or negative. An in-phase signal equals a positive rate, an out-of-phase signal indicates a negative rate. Also see pins 8, 31, 32
<b>J1-5</b>	<b>VERTICAL SPEED 26 V ac, 400 HZ REFERENCE INPUT (HI):</b> See pins 4 and 16.
<b>J1-8</b>	<b>VERTICAL SPEED VALID DISCRETE INPUT:</b> The VSI/TRA receives a 28 V dc signal from an ARINC 575 or 565 air data computer indicating its valid operation. An "open" at this pin indicates an invalid vertical speed signal from the ADC. This pin is only used when pins (1, 2, 3) or (4, 5, 6, and 16) are used. Also see pins 1 and 4.
<b>J1-9, 10</b>	<b>5-VOLT LAMP DIMMING INPUT: (J1-9 LOW, J1-10 HIGH)</b> The VSI/TRA monitors the cockpit lamp voltage bus at pins 9 and 10. This voltage may be either ac or dc. The back lighting in the VSI/TRA is adjusted by and tracks this voltage from 0.5 volts to 5 volts. If this input falls below 0.5 volts or is absent, the VSI/TRA sets itself to a nominal level to prevent the display from going dark due to loss or failure of the lamp dimming bus.
<b>J1-11</b>	<b>ARINC 429 (B) TCAS TA/RA DATA BUS INPUT:</b> Paired with pin 26. These pins connect to a TCAS computer unit.
<b>J1-12</b>	<b>ARINC 429 (B) VERTICAL SPEED NO. 1 INPUT BUS:</b> Paired with pin 27. These pins connect to Digital ADC No. 1 or PTM No 1.
<b>J1-14</b>	<b>ARINC 429 (B) VERTICAL SPEED NO. 2 INPUT:</b> Paired with pin 30. These pins connect to Digital ADC No. 2 or PTM No. 2.
<b>J1-15</b>	<b>CONFIGURATION STRAP COMMON INPUT:</b> This pin is the return line for the configuration strapping pins J1-17, J1-32 thru 38, and J1-41.





**SYSTEM DESCRIPTION AND INSTALLATION MANUAL**  
TCAS 3000 Traffic Alert and Collision Avoidance System

**Table 4-5. 41-Pin VSI/TRA Interface Descriptions (cont)**

Connector Pin Designation	Functional Description
J1-16	<b>VERTICAL SPEED 26 V ac, 400 HZ REFERENCE INPUT (LO):</b> See pins 4 and 5.
J1-17	<b>CONFIGURATION STRAP #3 INPUT (NO):</b> The VSI/TRA utilizes configuration strapping so unique aspects of any given installation may be identified and its functions supported. Each configuration strap (CS), and its associated function, becomes active when connected to program common, (J1-15). The inactive state of CS3 is open. This pin is monitored but unused in the -84X units. In -86X units it is paired with pin J1-34 (CS2) to configure the Lighting Curve and in -88X and -89X units it is paired with pin J1-41 (CS8) to select the desired Filter Time Constant. See pins 34 and 41.
J1-18	<b>PRESSURE TRANSDUCER MODULE POWER OUTPUT (COMMON):</b> An optional ACSS PTM may be used in an installation to supply ARINC 429 vertical speed information to the VSI/TRA. Pins 18, 19, and 20 supply input power to the PTM. Pin J1-18 is the power return pin and is connected to PTM pin 8.
J1-19	<b>PRESSURE TRANSDUCER MODULE -15 V dc POWER OUTPUT:</b> See pin 18. Connects to PTM pin 11.
J1-20	<b>PRESSURE TRANSDUCER MODULE +15 V dc POWER OUTPUT:</b> See pin 18. Connects to PTM pin 5.
J1-22	<b>CHASSIS GROUND INPUT:</b> Connected to aircraft frame. Also used to connect ARINC cable shields to the chassis.
J1-23	<b>115 V ac, 400 HZ POWER INPUT (COMMON):</b> See pin 40. Connect to aircraft AC ground.
J1-24, 25	<b>REMOTE LIGHT SENSOR INPUT: (J1-24 LOW, J1-25 HIGH)</b> This input at pins 24 and 25 provides a means of controlling the VSI/TRA back lighting via a remote light sensor already present in some aircraft (Douglas and Boeing). The VSI/TRA has its own built-in sensor and therefore a remote light sensor need not be used in all installations. Program the VSI/TRA for a remote light sensor, as described under pin 34.
J1-26	<b>ARINC 429 (A) TCAS TA/RA DATA INPUT:</b> Traffic and Resolution Advisory data is supplied to the VSI/TRA from the TCAS computer unit via this high speed ARINC 429 data bus. Paired with pin 11.
J1-27	<b>ARINC 429 (A) VERTICAL SPEED NO. 1 INPUT:</b> This is the primary ARINC 429 input bus to the VSI/TRA. This pin accepts high or low speed ARINC 429 vertical speed data (Label 212). Its use is determined by the source select discrete and configuration straps CS0 and CS1 (pins 31, 32, and 33 respectively). Paired with pin 12.
J1-29	<b>TA/RA VALID DISCRETE OUTPUT (NO):</b> This output discrete indicates the ability of the VSI/TRA to perform as a resolution advisory and/or a traffic advisory display. If the VSI/TRA fails, this discrete presents an open. Normal operation causes a ground. This discrete is monitored by the TCAS computer unit.



**SYSTEM DESCRIPTION AND INSTALLATION MANUAL**  
TCAS 3000 Traffic Alert and Collision Avoidance System

**Table 4-5. 41-Pin VSI/TRA Interface Descriptions (cont)**

Connector Pin Designation	Functional Description																																													
J1-30	<p><b>ARINC 429 (A) VERTICAL SPEED NO. 2 INPUT:</b> This is the secondary ARINC 429 input bus to the VSI/TRA. This pin accepts high or low speed ARINC 429 vertical speed data (Label 212). Its use is determined by the source select discrete and configuration straps CS0 and CS1 (pins 31, 32 and 33 respectively). Paired with pin 14.</p>																																													
J1-31	<p><b>SOURCE SELECT DISCRETE INPUT (NO):</b> This discrete input is used in conjunction with configuration straps CS0 and CS1 to program the VSI/TRA to accept and use the vertical speed data being supplied. In some installations, this discrete is connected to a switch in the cockpit and is used to select between primary and secondary ARINC 429 vertical speed inputs. It is hard wired to configuration strap common if ac or dc analog vertical speed inputs are used. Cycle power to update to the new configuration. The following applies: O = Open, G = Ground.</p> <table border="1" data-bbox="435 850 1156 1150"> <thead> <tr> <th></th> <th>SS</th> <th>CS0</th> <th>CS1</th> <th></th> </tr> <tr> <th>Pin</th> <th>31</th> <th>32</th> <th>33</th> <th>Definition</th> </tr> </thead> <tbody> <tr> <td></td> <td>O</td> <td>O</td> <td>O</td> <td>ARINC 429 HS Primary</td> </tr> <tr> <td></td> <td>G</td> <td>O</td> <td>O</td> <td>ARINC 429 HS Secondary</td> </tr> <tr> <td></td> <td>O</td> <td>G</td> <td>O</td> <td>Pressure Transducer Module (PTM)</td> </tr> <tr> <td></td> <td>G</td> <td>G</td> <td>O</td> <td>ARINC 575 dc</td> </tr> <tr> <td></td> <td>G</td> <td>O</td> <td>G</td> <td>ARINC 565 ac</td> </tr> <tr> <td></td> <td>O</td> <td>G</td> <td>G</td> <td>ARINC 429 LS Primary</td> </tr> <tr> <td></td> <td>G</td> <td>G</td> <td>G</td> <td>ARINC 429 LS Secondary</td> </tr> </tbody> </table>		SS	CS0	CS1		Pin	31	32	33	Definition		O	O	O	ARINC 429 HS Primary		G	O	O	ARINC 429 HS Secondary		O	G	O	Pressure Transducer Module (PTM)		G	G	O	ARINC 575 dc		G	O	G	ARINC 565 ac		O	G	G	ARINC 429 LS Primary		G	G	G	ARINC 429 LS Secondary
	SS	CS0	CS1																																											
Pin	31	32	33	Definition																																										
	O	O	O	ARINC 429 HS Primary																																										
	G	O	O	ARINC 429 HS Secondary																																										
	O	G	O	Pressure Transducer Module (PTM)																																										
	G	G	O	ARINC 575 dc																																										
	G	O	G	ARINC 565 ac																																										
	O	G	G	ARINC 429 LS Primary																																										
	G	G	G	ARINC 429 LS Secondary																																										
J1-32	<p><b>CONFIGURATION STRAP #0 INPUT (NO):</b> See pin 31.</p>																																													
J1-33	<p><b>CONFIGURATION STRAP #1 INPUT (NO):</b> See pin 31.</p>																																													



**SYSTEM DESCRIPTION AND INSTALLATION MANUAL**  
TCAS 3000 Traffic Alert and Collision Avoidance System

**Table 4-5. 41-Pin VSI/TRA Interface Descriptions (cont)**

Connector Pin Designation	Functional Description																																																
<p align="center"><b>J1-34</b></p>	<p><b>CONFIGURATION STRAP #2 INPUT (NO):</b> For -84X and -88X units, this pin programs the VSI/TRA to use the remote light sensor input at pins 24 and 25. If CS2 is open, a Boeing Airplane Company remote light sensor type (-10 to +10 V) is expected at pins 24 and 25. If grounded a Douglas Aircraft Company remote light sensor type (0 to 18 V) is programmed. Also see pin 25.</p> <p>For -89X units, CS2 is used to program the VSI display for English or Metric. If pin J1-34 is open, information is displayed in English. If grounded, the information is displayed in Metric.</p> <p>For -86X units, CS2 is used with CS3 (pin 17) to program the Lighting Curve. The following applies: O = Open, G = Ground</p> <table border="0" style="margin-left: auto; margin-right: auto;"> <thead> <tr> <th></th> <th align="center">CS2</th> <th align="center">CS3</th> <th></th> </tr> <tr> <th align="center">Pin</th> <th align="center">34</th> <th align="center">17</th> <th align="center">Definition</th> </tr> </thead> <tbody> <tr> <td></td> <td align="center">O</td> <td align="center">O</td> <td>Boeing (Normal Configuration)</td> </tr> <tr> <td></td> <td align="center">G</td> <td align="center">O</td> <td>McDonnell Douglas</td> </tr> <tr> <td></td> <td align="center">O</td> <td align="center">G</td> <td>Invalid (Displays VSI/TRA Red X fault if wired)</td> </tr> <tr> <td></td> <td align="center">G</td> <td align="center">G</td> <td>Invalid (Displays VSI/TRA Red X fault if wired)</td> </tr> </tbody> </table>		CS2	CS3		Pin	34	17	Definition		O	O	Boeing (Normal Configuration)		G	O	McDonnell Douglas		O	G	Invalid (Displays VSI/TRA Red X fault if wired)		G	G	Invalid (Displays VSI/TRA Red X fault if wired)																								
	CS2	CS3																																															
Pin	34	17	Definition																																														
	O	O	Boeing (Normal Configuration)																																														
	G	O	McDonnell Douglas																																														
	O	G	Invalid (Displays VSI/TRA Red X fault if wired)																																														
	G	G	Invalid (Displays VSI/TRA Red X fault if wired)																																														
<p align="center"><b>J1-35</b></p>	<p><b>CONFIGURATION STRAP #4 INPUT (NO):</b> For -86X, -88X, and -89X units, CS4 is paired with CS5 (pin 36) to program the VSI/TRA to display VSI only, VSI/RA or VSI/RA/TA. The following applies: O = Open, G = Ground</p> <table border="0" style="margin-left: auto; margin-right: auto;"> <thead> <tr> <th></th> <th align="center">CS4</th> <th align="center">CS5</th> <th></th> </tr> <tr> <th align="center">Pin</th> <th align="center">35</th> <th align="center">36</th> <th align="center">Definition</th> </tr> </thead> <tbody> <tr> <td></td> <td align="center">O</td> <td align="center">O</td> <td>VSI/RA/TA</td> </tr> <tr> <td></td> <td align="center">G</td> <td align="center">O</td> <td>VSI/RA</td> </tr> <tr> <td></td> <td align="center">O</td> <td align="center">G</td> <td>VSI Only</td> </tr> <tr> <td></td> <td align="center">G</td> <td align="center">G</td> <td>Invalid</td> </tr> </tbody> </table> <p>For -84X units, CS4 is paired with CS3 (pin 17) to program the Display Range Format. The following applies: O = Open, G = Ground</p> <table border="0" style="margin-left: auto; margin-right: auto;"> <thead> <tr> <th></th> <th align="center">CS4</th> <th align="center">CS3</th> <th></th> </tr> <tr> <th align="center">Pin</th> <th align="center">35</th> <th align="center">17</th> <th align="center">Definition</th> </tr> </thead> <tbody> <tr> <td></td> <td align="center">O</td> <td align="center">O</td> <td>14 Nautical Mile Range</td> </tr> <tr> <td></td> <td align="center">G</td> <td align="center">O</td> <td>6 Nautical Mile Range</td> </tr> <tr> <td></td> <td align="center">O</td> <td align="center">G</td> <td>40 nautical Mile Range</td> </tr> <tr> <td></td> <td align="center">G</td> <td align="center">G</td> <td>6 Nautical Mile Range</td> </tr> </tbody> </table>		CS4	CS5		Pin	35	36	Definition		O	O	VSI/RA/TA		G	O	VSI/RA		O	G	VSI Only		G	G	Invalid		CS4	CS3		Pin	35	17	Definition		O	O	14 Nautical Mile Range		G	O	6 Nautical Mile Range		O	G	40 nautical Mile Range		G	G	6 Nautical Mile Range
	CS4	CS5																																															
Pin	35	36	Definition																																														
	O	O	VSI/RA/TA																																														
	G	O	VSI/RA																																														
	O	G	VSI Only																																														
	G	G	Invalid																																														
	CS4	CS3																																															
Pin	35	17	Definition																																														
	O	O	14 Nautical Mile Range																																														
	G	O	6 Nautical Mile Range																																														
	O	G	40 nautical Mile Range																																														
	G	G	6 Nautical Mile Range																																														



**SYSTEM DESCRIPTION AND INSTALLATION MANUAL**  
TCAS 3000 Traffic Alert and Collision Avoidance System

**Table 4-5. 41-Pin VSI/TRA Interface Descriptions (cont)**

Connector Pin Designation	Functional Description																								
<b>J1-36</b>	<p><b>CONFIGURATION STRAP #5 INPUT (NO):</b> For -86X, -88X, and -89X units, see pin 35. For -84X units, CS5 is paired with CS6 (pin 37) to program the Altitude Band. The following apply: O = Open, G = Ground</p> <table align="center"> <thead> <tr> <th></th> <th align="center">CS5</th> <th align="center">CS6</th> <th></th> </tr> <tr> <th align="center">Pin</th> <th align="center">36</th> <th align="center">37</th> <th align="center">Definition</th> </tr> </thead> <tbody> <tr> <td></td> <td align="center">O</td> <td align="center">O</td> <td>Normal -A to +A</td> </tr> <tr> <td></td> <td align="center">G</td> <td align="center">O</td> <td>Above -A to +B</td> </tr> <tr> <td></td> <td align="center">O</td> <td align="center">G</td> <td>Below -B to +A</td> </tr> <tr> <td></td> <td align="center">G</td> <td align="center">G</td> <td>Unrestricted Range</td> </tr> </tbody> </table>		CS5	CS6		Pin	36	37	Definition		O	O	Normal -A to +A		G	O	Above -A to +B		O	G	Below -B to +A		G	G	Unrestricted Range
	CS5	CS6																							
Pin	36	37	Definition																						
	O	O	Normal -A to +A																						
	G	O	Above -A to +B																						
	O	G	Below -B to +A																						
	G	G	Unrestricted Range																						
<b>J1-37</b>	<p><b>CONFIGURATION STRAP #6 INPUT (NO):</b> For -84X units this pin is paired with CS5 to program the altitude band. See pin 36. For -86X, -88X, and -89X units, CS6 is used to program the Traffic Filter. If pin 37 is Open, the VSI/TRA is programmed to NOT display other traffic. If pin 37 is grounded, other traffic is displayed.</p>																								
<b>J1-38</b>	<p><b>CONFIGURATION STRAP #7 INPUT (NO):</b> This configuration strap is used during factory test to take the VSI/TRA out of flight mode and into test mode when grounded. This pin must be left unwired, "Open" in all aircraft installations.</p>																								
<b>J1-39</b>	<p><b>DC GROUND INPUT:</b> To be connected to aircraft dc Ground.</p>																								
<b>J1-40</b>	<p><b>115 V ac, 400 HZ POWER INPUT (HI):</b> This pin, along with its return line (pin 23) supplies power to the VSI/TRA. Connect power through a 1 Amp circuit breaker.</p>																								
<b>J1-41</b>	<p><b>CONFIGURATION STRAP #8 INPUT (NO):</b> For -88X and -89X units, CS8 is paired with CS3 (pin 17) to program the Filter Time Constant. The following apply: O = Open, G = Ground</p> <table align="center"> <thead> <tr> <th></th> <th align="center">CS8</th> <th align="center">CS3</th> <th></th> </tr> <tr> <th align="center">Pin</th> <th align="center">41</th> <th align="center">17</th> <th align="center">Definition</th> </tr> </thead> <tbody> <tr> <td></td> <td align="center">O</td> <td align="center">O</td> <td>5.0 Second Delay</td> </tr> <tr> <td></td> <td align="center">O</td> <td align="center">G</td> <td>6.4 Second Delay</td> </tr> <tr> <td></td> <td align="center">G</td> <td align="center">O</td> <td>3.2 Second Delay</td> </tr> <tr> <td></td> <td align="center">G</td> <td align="center">G</td> <td>1.6 Second Delay</td> </tr> </tbody> </table>		CS8	CS3		Pin	41	17	Definition		O	O	5.0 Second Delay		O	G	6.4 Second Delay		G	O	3.2 Second Delay		G	G	1.6 Second Delay
	CS8	CS3																							
Pin	41	17	Definition																						
	O	O	5.0 Second Delay																						
	O	G	6.4 Second Delay																						
	G	O	3.2 Second Delay																						
	G	G	1.6 Second Delay																						



**SYSTEM DESCRIPTION AND INSTALLATION MANUAL**  
TCAS 3000 Traffic Alert and Collision Avoidance System

**Table 4-6. 55-Pin VSI/TRA Interface Descriptions**

Connector Pin Designation	Functional Description
J1-1, 6	<p><b>SECONDARY ARINC 565 VERTICAL SPEED BUS INPUT: [J1-6 (HI), J1-1 (LO)]</b></p> <p>This two wire bus input receives ARINC 565 vertical speed data from the cross-side display when the bootstrap mode is activated. This bus input is connected to the R/C Bootstrap Output bus on the cross-side display as follows:</p> <p>J1-6 of the on-side display is connected to J1-14 of the cross-side display. J1-1 of the on-side display is connected to J1-13 of the cross-side display.</p>
J1-2	<p><b>VERTICAL SPEED DC RATE INPUT:</b></p> <p>Pins 2, 3 and 8 are inputs to the VSI/TRA from an ARINC 575 air data computer indicating vertical speed. Pin 2 receives a +10 to -10 V dc rate signal from the ADC. Pin 3 is a -12 V dc regulated reference voltage from the ADC and pin 8 is a +12 V dc regulated reference voltage from the ADC. Also see pins 29, 31, 32, and 33.</p>
J1-3	<p><b>VERTICAL SPEED -DC REFERENCE INPUT:</b></p> <p>See pin 2.</p>
J1-4	<p><b>BOOTSTRAP REFERENCE OUTPUT:</b></p> <p>This output sends the bootstrap ARINC 565 ac reference voltage to the cross-side display. The output is connected to the Secondary 26 V ac Reference Input (pin 7) of the cross-side display.</p>
J1-5	<p><b>VERTICAL SPEED NO. 2 VALID DISCRETE INPUT:</b></p> <p>This discrete input receives bootstrap ARINC 565 vertical speed valid data from the cross-side display. The input is connected to the Vertical Speed Output (pin 49) of the cross-side display.</p>
J1-7	<p><b>SECONDARY 26 V ac REFERENCE INPUT:</b></p> <p>This input receives the bootstrap ARINC 565 ac reference voltage from the cross-side display. The input is connected to the Bootstrap Reference Output (pin 40) of the cross-side display.</p>
J1-8	<p><b>VERTICAL SPEED +DC REFERENCE INPUT:</b></p> <p>See pin 2.</p>
J1-9	<p><b>PRIMARY VERTICAL SPEED 26 V ac, 400 HZ REFERENCE INPUT:</b></p> <p>See pins 10, 11.</p>
J1-10, 11	<p><b>PRIMARY VERTICAL SPEED ARINC 565 AC INPUT: (J1-11 HIGH, J1-10 LOW)</b></p> <p>Pins 9, 10, 11, and 12 are inputs to the VSI/TRA from an ARINC 565 air data computer or IRS. A 26 V ac, 400 Hz reference signal is received on pin 9 (HI). Pin 11 (HI) and pin 10 (LO) provide an amplitude modulated 400 Hz signal with a maximum voltage of <math>\pm 6.25</math> volts. The RMS value of this signal is used by the VSI/TRA to compute and display the vertical rate. The phase of this signal is compared with the reference signal to determine if the rate is positive or negative. An in-phase equals a positive rate, an out-of-phase signal indicates a negative rate. Also see pins 12, 29, 31, 32, and 33.</p>



**SYSTEM DESCRIPTION AND INSTALLATION MANUAL**  
TCAS 3000 Traffic Alert and Collision Avoidance System

**Table 4-6. 55-Pin VSI/TRA Interface Descriptions (cont)**

Connector Pin Designation	Functional Description																																								
J1-12	<p><b>VERTICAL SPEED NO. 1 VALID DISCRETE INPUT:</b></p> <p>The VSI/TRA receives a 28 V dc signal from an ARINC 575 or 565 air data computer indicating its valid operation. An “Open” at this pin indicates an invalid vertical speed signal from ADC #1. This pin is only used when pins ( 2, 3, 8) or (9, 10, 11) are used and on the #1 VSI/TRA display. Also see pins 2, 10, and 11.</p>																																								
J1-13, 14	<p><b>R/C BOOTSTRAP OUTPUT: [J1-14 (HI), J1-13 (LO)]</b></p> <p>This two wire bus output sends ARINC 565 vertical speed data to the cross-side display when the bootstrap mode is activated. These pins are connected to the ARINC 565 Secondary Vertical Speed Input bus on the cross-side display as follows: J1-14 of the on-side display is connected to J1-6 of the cross-side display. J1-13 of the on-side display is connected to J1-1 of the cross-side display.</p>																																								
J1-15	<p><b>BOOTSTRAP COMMAND OUTPUT:</b></p> <p>This pin is connected to the Source Select #2 (SS2) discrete input, pin 29, within the VSI/TRA. The output provides an Open/28 V dc discrete that can be used to annunciate the bootstrap function. This output is normally not used.</p>																																								
J1-17	<p><b>CONFIGURATION STRAP #5 INPUT (NO):</b></p> <p>For -84X units, CS5 is paired with CS6 (pin 37) to program the altitude band. The following apply: O = Open, G = Ground</p> <table border="1" data-bbox="625 1045 1101 1249"> <thead> <tr> <th>Pin</th> <th>CS5 17</th> <th>CS6 18</th> <th>Definition</th> </tr> </thead> <tbody> <tr> <td></td> <td>O</td> <td>O</td> <td>Normal -A to +A</td> </tr> <tr> <td></td> <td>G</td> <td>O</td> <td>Above -A to +B</td> </tr> <tr> <td></td> <td>O</td> <td>G</td> <td>Below -B to +A</td> </tr> <tr> <td></td> <td>G</td> <td>G</td> <td>Unrestricted Range</td> </tr> </tbody> </table> <p>For -86X, -88X and -89X units, CS5 is paired with CS4 (pin 36) to program the Display Format. The following apply: O = Open, G = Ground</p> <table border="1" data-bbox="625 1329 1003 1535"> <thead> <tr> <th>Pin</th> <th>CS5 17</th> <th>CS4 36</th> <th>Definition</th> </tr> </thead> <tbody> <tr> <td></td> <td>O</td> <td>O</td> <td>VSI/RA/TA</td> </tr> <tr> <td></td> <td>O</td> <td>G</td> <td>VSI/RA</td> </tr> <tr> <td></td> <td>G</td> <td>O</td> <td>VSI Only</td> </tr> <tr> <td></td> <td>G</td> <td>G</td> <td>Invalid</td> </tr> </tbody> </table>	Pin	CS5 17	CS6 18	Definition		O	O	Normal -A to +A		G	O	Above -A to +B		O	G	Below -B to +A		G	G	Unrestricted Range	Pin	CS5 17	CS4 36	Definition		O	O	VSI/RA/TA		O	G	VSI/RA		G	O	VSI Only		G	G	Invalid
Pin	CS5 17	CS6 18	Definition																																						
	O	O	Normal -A to +A																																						
	G	O	Above -A to +B																																						
	O	G	Below -B to +A																																						
	G	G	Unrestricted Range																																						
Pin	CS5 17	CS4 36	Definition																																						
	O	O	VSI/RA/TA																																						
	O	G	VSI/RA																																						
	G	O	VSI Only																																						
	G	G	Invalid																																						
J1-18	<p><b>CONFIGURATION STRAP #6 INPUT (NO):</b></p> <p>For -84X units, see pin 17.</p> <p>For -86X, -88X, and -89X units CS6 is used to program the Traffic Filter. If pin 18 is Open, the VSI/TRA is programmed to not display other traffic. If pin 18 is grounded, other traffic will be displayed.</p>																																								
J1-19	<p><b>CONFIGURATION STRAP #7 INPUT (NO):</b></p> <p>This configuration strap is used during factory test to take the VSI/TRA out of flight mode and into test mode when grounded. This pin must be left unwired, “Open” in all aircraft installations.</p>																																								



**SYSTEM DESCRIPTION AND INSTALLATION MANUAL**  
TCAS 3000 Traffic Alert and Collision Avoidance System

**Table 4-6. 55-Pin VSI/TRA Interface Descriptions (cont)**

Connector Pin Designation	Functional Description																				
<b>J1-20</b>	<b>CHASSIS GROUND INPUT:</b> Connected to aircraft frame. Also used to connect ARINC cable shields to the chassis.																				
<b>J1-21</b>	<b>DC GROUND INPUT:</b> To be connected to aircraft dc Ground.																				
<b>J1-22</b>	<p><b>CONFIGURATION STRAP #8 INPUT (NO):</b> For -84X and -86X units, CS8 is not used and pin J1-22 must remain Open. For -88X and -89X units, CS8 is paired with CS3 (pin 35) to program the Filter Time Constant. The following apply: O = Open, G = Ground</p> <table border="0" style="margin-left: auto; margin-right: auto;"> <thead> <tr> <th style="text-align: left;">Pin</th> <th style="text-align: center;">CS8 22</th> <th style="text-align: center;">CS3 35</th> <th style="text-align: left;">Definition</th> </tr> </thead> <tbody> <tr> <td></td> <td align="center">O</td> <td align="center">O</td> <td>5.0 Second Delay</td> </tr> <tr> <td></td> <td align="center">O</td> <td align="center">G</td> <td>6.4 Second Delay</td> </tr> <tr> <td></td> <td align="center">G</td> <td align="center">O</td> <td>3.2 Second Delay</td> </tr> <tr> <td></td> <td align="center">G</td> <td align="center">G</td> <td>1.6 Second Delay</td> </tr> </tbody> </table>	Pin	CS8 22	CS3 35	Definition		O	O	5.0 Second Delay		O	G	6.4 Second Delay		G	O	3.2 Second Delay		G	G	1.6 Second Delay
Pin	CS8 22	CS3 35	Definition																		
	O	O	5.0 Second Delay																		
	O	G	6.4 Second Delay																		
	G	O	3.2 Second Delay																		
	G	G	1.6 Second Delay																		
<b>J1-23,24</b>	<p><b>REMOTE LIGHT SENSOR INPUT: (J1-23 HIGH, J1-24 LOW )</b> This input at pins 23 and 24 provides a means of controlling the VSI/TRA back lighting via a remote light sensor already present in some aircraft (Douglas and Boeing). The VSI/TRA has its own built-in sensor and therefore a remote light sensor need not be used in all installations. Program the VSI/TRA for a remote light sensor, as described under pin 34 and 35.</p>																				
<b>J1-25, 44</b>	<p><b>ARINC 429 TCAS BUS INPUT: [J1-25 (A), J1-44 (B)]</b> This differential pair input is a high speed ARINC 429 bus (100K bit/second nominal) that receives Traffic and Resolution Advisory data supplied by the TCAS computer unit.</p>																				
<b>J1-26, 45</b>	<p><b>ARINC 429 VERTICAL SPEED NO. 2 BUS INPUT: [J1-26 (A), J1-45 (B)]</b> This differential pair input is a low speed bus (12.5K bits/second nominal) that receives ARINC 429 vertical speed data from the secondary (#2) digital ADC or the #2 PTM.</p>																				
<b>J1-27, 46</b>	<p><b>ARINC 429 INERTIAL REFERENCE SYSTEM BUS INPUT: [J1-27 (A), J1-46 (B)]</b> This differential pair input is a low speed ARINC 429 bus (12.5K bits/second nominal) that receives vertical speed data from an Inertial Reference System.</p>																				
<b>J1-28</b>	<p><b>RA VALID DISCRETE OUTPUT:</b> This output discrete indicates the ability of the VSI/TRA to perform as a resolution advisory and/or a traffic advisory display. If the VSI/TRA fails, this discrete presents an open. Normal operation causes a ground. This discrete is monitored by the TCAS computer unit.</p>																				



**SYSTEM DESCRIPTION AND INSTALLATION MANUAL**  
TCAS 3000 Traffic Alert and Collision Avoidance System

**Table 4-6. 55-Pin VSI/TRA Interface Descriptions (cont)**

Connector Pin Designation	Functional Description																																																																								
<p align="center"><b>J1-29</b></p>	<p><b>SOURCE SELECT #2 DISCRETE INPUT:</b></p> <p>This discrete input is used in conjunction with source select discrete #1 (SS1) and configuration straps CS0 and CS1 to program the VSI/TRA to accept and use the vertical speed data being supplied. The following applies: O = Open, G = Ground, 28V = 28 V dc and X = Don't Care.</p> <table border="1"> <thead> <tr> <th></th> <th>SS2</th> <th>SS1</th> <th>CS0</th> <th>CS1</th> <th></th> </tr> <tr> <th>Pin</th> <th>29</th> <th>31</th> <th>32</th> <th>33</th> <th>Definition</th> </tr> </thead> <tbody> <tr> <td></td> <td>X</td> <td>O</td> <td>O</td> <td>O</td> <td>ARINC 429 HS Primary</td> </tr> <tr> <td></td> <td>X</td> <td>G</td> <td>O</td> <td>O</td> <td>ARINC 429 HS Secondary</td> </tr> <tr> <td></td> <td>X</td> <td>O</td> <td>G</td> <td>O</td> <td>Pressure Transducer Module (PTM)</td> </tr> <tr> <td></td> <td>X</td> <td>G</td> <td>G</td> <td>O</td> <td>ARINC 575 ADC</td> </tr> <tr> <td></td> <td>28V</td> <td>O</td> <td>O</td> <td>G</td> <td>A310 ADC Secondary</td> </tr> <tr> <td></td> <td>O</td> <td>O</td> <td>O</td> <td>G</td> <td>A310 ADC Primary</td> </tr> <tr> <td></td> <td>28V</td> <td>G</td> <td>O</td> <td>G</td> <td>ARINC 565 ac Secondary</td> </tr> <tr> <td></td> <td>O</td> <td>G</td> <td>O</td> <td>G</td> <td>ARINC 565 ac Primary</td> </tr> <tr> <td></td> <td>X</td> <td>O</td> <td>G</td> <td>G</td> <td>ARINC 429 LS Primary</td> </tr> <tr> <td></td> <td>X</td> <td>G</td> <td>G</td> <td>G</td> <td>ARINC 429 LS Secondary</td> </tr> </tbody> </table>		SS2	SS1	CS0	CS1		Pin	29	31	32	33	Definition		X	O	O	O	ARINC 429 HS Primary		X	G	O	O	ARINC 429 HS Secondary		X	O	G	O	Pressure Transducer Module (PTM)		X	G	G	O	ARINC 575 ADC		28V	O	O	G	A310 ADC Secondary		O	O	O	G	A310 ADC Primary		28V	G	O	G	ARINC 565 ac Secondary		O	G	O	G	ARINC 565 ac Primary		X	O	G	G	ARINC 429 LS Primary		X	G	G	G	ARINC 429 LS Secondary
	SS2	SS1	CS0	CS1																																																																					
Pin	29	31	32	33	Definition																																																																				
	X	O	O	O	ARINC 429 HS Primary																																																																				
	X	G	O	O	ARINC 429 HS Secondary																																																																				
	X	O	G	O	Pressure Transducer Module (PTM)																																																																				
	X	G	G	O	ARINC 575 ADC																																																																				
	28V	O	O	G	A310 ADC Secondary																																																																				
	O	O	O	G	A310 ADC Primary																																																																				
	28V	G	O	G	ARINC 565 ac Secondary																																																																				
	O	G	O	G	ARINC 565 ac Primary																																																																				
	X	O	G	G	ARINC 429 LS Primary																																																																				
	X	G	G	G	ARINC 429 LS Secondary																																																																				
<p align="center"><b>J1-31</b></p>	<p><b>SOURCE SELECT #1 DISCRETE INPUT (NO):</b></p> <p>See pin 29.</p>																																																																								
<p align="center"><b>J1-32</b></p>	<p><b>CONFIGURATION STRAP #0 INPUT (NO):</b></p> <p>See pin 29.</p>																																																																								
<p align="center"><b>J1-33</b></p>	<p><b>CONFIGURATION STRAP #1 INPUT (NO):</b></p> <p>See pin 29.</p>																																																																								
<p align="center"><b>J1-34</b></p>	<p><b>CONFIGURATION STRAP #2 INPUT (NO):</b></p> <p>For -84X and -88X units, this pin programs the VSI/TRA to use the remote light sensor input at pins 23 and 24. If CS2 is open, a Boeing Airplane Company remote light sensor type (-10 to +10 V) is expected at pins 23 and 24. If pin 34 is grounded, a McDonnell Douglas Aircraft Company remote light sensor type (0 to 18 V) is programmed. Also see pins 23/24.</p> <p>For -89X units, CS2 is used to program the VSI display for English or Metric. If pin J1-34 is open, information is displayed in English. If pin 34 is grounded, the information is displayed in Metric.</p> <p>For -86X units, CS2 is used with CS3 (pin 17) to program the lighting curve. The following applies: O = Open, G = Ground</p> <table border="1"> <thead> <tr> <th></th> <th>CS2</th> <th>CS3</th> <th></th> </tr> <tr> <th>Pin</th> <th>34</th> <th>35</th> <th>Definition</th> </tr> </thead> <tbody> <tr> <td></td> <td>O</td> <td>O</td> <td>Boeing (Normal Configuration)</td> </tr> <tr> <td></td> <td>G</td> <td>O</td> <td>McDonnell Douglas</td> </tr> <tr> <td></td> <td>O</td> <td>G</td> <td>Invalid (Displays VSI/TRA Red X fault if wired)</td> </tr> <tr> <td></td> <td>G</td> <td>G</td> <td>Invalid (Displays VSI/TRA Red X fault if wired)</td> </tr> </tbody> </table>		CS2	CS3		Pin	34	35	Definition		O	O	Boeing (Normal Configuration)		G	O	McDonnell Douglas		O	G	Invalid (Displays VSI/TRA Red X fault if wired)		G	G	Invalid (Displays VSI/TRA Red X fault if wired)																																																
	CS2	CS3																																																																							
Pin	34	35	Definition																																																																						
	O	O	Boeing (Normal Configuration)																																																																						
	G	O	McDonnell Douglas																																																																						
	O	G	Invalid (Displays VSI/TRA Red X fault if wired)																																																																						
	G	G	Invalid (Displays VSI/TRA Red X fault if wired)																																																																						





**SYSTEM DESCRIPTION AND INSTALLATION MANUAL**  
TCAS 3000 Traffic Alert and Collision Avoidance System

**Table 4-6. 55-Pin VSI/TRA Interface Descriptions (cont)**

Connector Pin Designation	Functional Description																								
<b>J1-35</b>	<p><b>CONFIGURATION STRAP #3 INPUT (NO):</b></p> <p>For -86X units, CS3 is paired with CS2 to program the Lighting Curve. See pin 34.</p> <p>For -88X and -89X units, CS3 is paired with CS8 to program the Filter Time Constant. See pin 22.</p> <p>For -84X units, CS3 is paired with CS4 (pin 36) to program the display Range Format. The following applies: O = Open, G = Ground</p> <table border="0" style="margin-left: auto; margin-right: auto;"> <thead> <tr> <th></th> <th align="center">CS3</th> <th align="center">CS4</th> <th></th> </tr> <tr> <th align="left">Pin</th> <th align="center">35</th> <th align="center">36</th> <th align="left">Definition</th> </tr> </thead> <tbody> <tr> <td></td> <td align="center">O</td> <td align="center">O</td> <td>14 Nautical Mile Range</td> </tr> <tr> <td></td> <td align="center">O</td> <td align="center">G</td> <td>6 Nautical Mile Range</td> </tr> <tr> <td></td> <td align="center">G</td> <td align="center">O</td> <td>40 Nautical Mile Range</td> </tr> <tr> <td></td> <td align="center">G</td> <td align="center">G</td> <td>6 Nautical Mile Range</td> </tr> </tbody> </table>		CS3	CS4		Pin	35	36	Definition		O	O	14 Nautical Mile Range		O	G	6 Nautical Mile Range		G	O	40 Nautical Mile Range		G	G	6 Nautical Mile Range
	CS3	CS4																							
Pin	35	36	Definition																						
	O	O	14 Nautical Mile Range																						
	O	G	6 Nautical Mile Range																						
	G	O	40 Nautical Mile Range																						
	G	G	6 Nautical Mile Range																						
<b>J1-36</b>	<p><b>CONFIGURATION STRAP #4 INPUT (NO):</b></p> <p>For -84X units, CS4 is paired with CS3 to program the Range Format. See pin 35.</p> <p>For -86X, -88X, and -89X units, CS4 is paired with CS5 to program the Display Format. See pin 17.</p>																								
<b>J1-37</b>	<p><b>CONFIGURATION STRAP COMMON INPUT:</b></p> <p>This pin is the return line for the configuration strapping pins J1-17, 18, 19, 22, and J1-32 thru 36. The VSI/TRA uses configuration strapping so unique aspects of any given installation may be identified and its functions supported. Each configuration strap (CS) and its associated function becomes active when connected to program common (J1-37).</p>																								
<b>J1-38</b>	<p><b>115 V ac, 400 HZ POWER INPUT (COMMON):</b></p> <p>See pin 40. Connect to aircraft AC ground.</p>																								
<b>J1-40</b>	<p><b>115 V ac, 400 HZ POWER INPUT (HIGH):</b></p> <p>This pin, along with its return line (pin 38) supplies power to the VSI/TRA. Connect power through a 1 Amp circuit breaker.</p>																								
<b>J1-42, 43</b>	<p><b>5-VOLT LAMP DIMMING INPUT: (J1-42 LOW, J1-43 HIGH)</b></p> <p>The VSI/TRA monitors the cockpit lamp voltage bus at pins 42 and 43. This voltage may be either ac or dc. The back lighting in the VSI/TRA is adjusted by and tracks this voltage from 0.5 volts to 5 volts. If this input falls below 0.5 volts or is absent, the VSI/TRA sets itself to a nominal level to prevent the display from going dark due to loss or failure of the lamp dimming bus.</p>																								
<b>J1-47, 48</b>	<p><b>ARINC 429 VERTICAL SPEED NO. 1 BUS INPUT: [J1-47 (A), J1-48 (B)]</b></p> <p>This differential pair input is a low speed bus (12.5K bits/second nominal) that receives ARINC 429 vertical speed data from the primary (#1) digital ADC or the #1 PTM.</p>																								
<b>J1-49</b>	<p><b>VERTICAL SPEED VALID DISCRETE OUTPUT:</b></p> <p>This discrete output sends bootstrap ARINC 565 vertical speed valid data to the cross-side display. The output is connected to the Vertical Speed Valid Input (pin J1-5) of the cross-side display.</p>																								



**SYSTEM DESCRIPTION AND INSTALLATION MANUAL**  
TCAS 3000 Traffic Alert and Collision Avoidance System

**Table 4-6. 55-Pin VSI/TRA Interface Descriptions (cont)**

<b>Connector Pin Designation</b>	<b>Functional Description</b>
<b>J1-50</b>	<b>PRESSURE TRANSDUCER MODULE -15 V dc POWER OUTPUT:</b> An optional ACSS PTM may be used in an installation to supply vertical speed information to the VSI/TRA. Pins 50, 51, and 52 supply input power to the PTM. Pin J1-50 is the -15 V dc output pin and is connected to PTM pin 11.
<b>J1-51</b>	<b>PRESSURE TRANSDUCER MODULE POWER OUTPUT (COMMON):</b> Connects to PTM pin 8. See pin 50.
<b>J1-52</b>	<b>PRESSURE TRANSDUCER MODULE +15 V dc POWER OUTPUT:</b> Connects to PTM pin 5. See pin 50.



**SYSTEM DESCRIPTION AND INSTALLATION MANUAL**  
TCAS 3000 Traffic Alert and Collision Avoidance System

**Table 4-7. Pressure Transducer Module Interface Descriptions**

<b>Connector Pin Designation</b>	<b>Functional Description</b>
<b>J1-1</b>	<b>CHASSIS GROUND INPUT:</b> Tied to aircraft frame. Also used to connect ARINC 429 cable shields to the chassis.
<b>J1-2</b>	<b>EXTERNAL RESET INPUT:</b> This pin is used by factory test only. Do not connect this pin in aircraft installations.
<b>J1-3</b>	<b>FAULT DISCRETE OUTPUT:</b> This pin is used by factory test only. Do not connect this pin in aircraft installations.
<b>J1-5</b>	<b>+15 V dc POWER INPUT:</b> This power input is supplied by the VSI/TRA. The PTM receives $\pm 15$ V dc from the VSI/TRA. The $\pm 12$ V dc used by the PTM is derived from this source.
<b>J1-7</b>	<b>VERTICAL SPEED ARINC 429 (A) BUS OUTPUT:</b> Bus output that is paired with J1-13 to transmit vertical speed information to the VSI/TRA.
<b>J1-8</b>	<b><math>\pm 15</math> V dc POWER GROUND INPUT:</b> This pin is the $\pm 15$ V dc return from the VSI/TRA. It must be connected to the VSI/TRA. Also see pins 5 and 11.
<b>J1-11</b>	<b>-15 V dc POWER INPUT:</b> See pin 5.
<b>J1-13</b>	<b>VERTICAL SPEED ARINC 429 (B) BUS OUTPUT:</b> See pin 7.



**SYSTEM DESCRIPTION AND INSTALLATION MANUAL**  
TCAS 3000 Traffic Alert and Collision Avoidance System

**Table 4–8. XS–950 Data Link Transponder Interface Descriptions**

Connector Pin Designation	Functional Description
<b>P1A–1A THRU P1A–1K, AND P1A–2K</b>	<b>ENCODING ALTIMETER #2 INPUTS:</b> These Mode C pulse discrete inputs allow for altitude inputs from an encoding altimeter that contains a discrete 11 wire interface. The standards for this interface are defined in ARINC Characteristic 572, “Air Traffic Control Transponder”. The inputs use ground/open logic levels. <b>NOTE:</b> Two encoding altimeters are required if the transponder is used with TCAS.
<b>P1A–2A, 2B</b>	<b>ARINC 429 ADLP TO COMM A/B BUS INPUT: [P1A–2A (A), P1A–2B (B)]</b> <b>or</b> <b>ARINC 429 FMC/GNSS Input</b> Four ARINC 429 busses are provided for interfacing to a Mode S Airborne Data Link Processor (ADLP). The COMM A/B input and output busses are used for the transfer of standard length messages to and from the ADLP. The COMM C/D input and output busses are used for the transfer of extended length messages (ELM) to and from the ADLP. P1A–2A and 2B can also be configured to a FMC/GNSS input. The standard for this interface is defined on ARINC 718–A. For additional information on the FMC/GNSS input, refer to ARINC 743A. This input is configured by grounding or opening P1B–5H.
<b>P1A–2C, 2D</b>	<b>ARINC 429 ADLP TO COMM C/D BUS INPUT: [P1A–2C (A), P1A–2D (B)]</b> <b>or</b> <b>ARINC 429 IRS/RMS/Data Concentrator</b> See pins P1A–2A, –2B
<b>P1A–2E, 2F</b>	<b>ARINC 429 COMM C/D TO ADLP BUS OUTPUT: [P1A–2E (A), P1A–2F (B)]</b> <b>or</b> <b>ARINC 429 General Output Bus</b> See pins P1A–2A, –2B
<b>P1A–3B</b>	<b>XPDR FAIL DISCRETE OUTPUT #2:</b> This discrete output is set to annunciate an internal transponder failure or the Mode S address is illegal (All 0’s or 1’s). A ground logic threshold (<3.0 V dc) is output when the transponder is operating normally, and an open logic threshold (resistance >100K ohms to unit ground) when a failure has occurred. The output is capable of sinking 200 mA of current. Connect this pin to the Control Panel XPDR FAIL #2 input.



**SYSTEM DESCRIPTION AND INSTALLATION MANUAL**  
TCAS 3000 Traffic Alert and Collision Avoidance System

**Table 4-8. XS-950 Data Link Transponder Interface Descriptions (cont)**

Connector Pin Designation	Functional Description																																																
<b>P1A-3C, P1A-3D, P1A-3E, P1A-3F</b>	<p><b>CABLE DELAY PROGRAM INPUTS:</b></p> <p>The Cable Delay Program Inputs are used to compensate for the difference in propagation delays in the transponder due to antenna transmission line length differences between the top and bottom antennas. The inputs use ground/open logic levels. The Cable Delay Program Common (pin P1A-3F) can be used to supply a ground.</p> <table border="1" data-bbox="326 569 1365 926"> <thead> <tr> <th colspan="3">Program Pin</th> <th rowspan="2">Differential Delay</th> <th rowspan="2">Transponder Adjustment</th> </tr> <tr> <th>P1A-3C</th> <th>P1A-3D</th> <th>P1A-3E</th> </tr> </thead> <tbody> <tr> <td>Open</td> <td>Open</td> <td>Open</td> <td>0-50 nsec</td> <td>No Change</td> </tr> <tr> <td>Open</td> <td>Open</td> <td>Ground</td> <td>51-150 nsec</td> <td>Add Delay to Top Channel</td> </tr> <tr> <td>Open</td> <td>Ground</td> <td>Open</td> <td>151-250 nsec</td> <td>Add Delay to Top Channel</td> </tr> <tr> <td>Open</td> <td>Ground</td> <td>Ground</td> <td>251-350 nsec</td> <td>Add Delay to Top Channel</td> </tr> <tr> <td>Ground</td> <td>Open</td> <td>Open</td> <td>0-50 nsec</td> <td>No Change</td> </tr> <tr> <td>Ground</td> <td>Open</td> <td>Ground</td> <td>51-150 nsec</td> <td>Add Delay to Bottom Channel</td> </tr> <tr> <td>Ground</td> <td>Ground</td> <td>Open</td> <td>151-250 nsec</td> <td>Add Delay to Bottom Channel</td> </tr> <tr> <td>Ground</td> <td>Ground</td> <td>Ground</td> <td>251-350 nsec</td> <td>Add Delay to Bottom Channel</td> </tr> </tbody> </table> <p>The differential delay column is the difference in the round trip cable delay between the top and bottom antenna cables. The differential delay can be calculated as follows:</p> <p>[Top length in feet - Bottom length in feet] X [Characteristic Delay (nsec/foot)] X 2.</p>	Program Pin			Differential Delay	Transponder Adjustment	P1A-3C	P1A-3D	P1A-3E	Open	Open	Open	0-50 nsec	No Change	Open	Open	Ground	51-150 nsec	Add Delay to Top Channel	Open	Ground	Open	151-250 nsec	Add Delay to Top Channel	Open	Ground	Ground	251-350 nsec	Add Delay to Top Channel	Ground	Open	Open	0-50 nsec	No Change	Ground	Open	Ground	51-150 nsec	Add Delay to Bottom Channel	Ground	Ground	Open	151-250 nsec	Add Delay to Bottom Channel	Ground	Ground	Ground	251-350 nsec	Add Delay to Bottom Channel
Program Pin			Differential Delay	Transponder Adjustment																																													
P1A-3C	P1A-3D	P1A-3E																																															
Open	Open	Open	0-50 nsec	No Change																																													
Open	Open	Ground	51-150 nsec	Add Delay to Top Channel																																													
Open	Ground	Open	151-250 nsec	Add Delay to Top Channel																																													
Open	Ground	Ground	251-350 nsec	Add Delay to Top Channel																																													
Ground	Open	Open	0-50 nsec	No Change																																													
Ground	Open	Ground	51-150 nsec	Add Delay to Bottom Channel																																													
Ground	Ground	Open	151-250 nsec	Add Delay to Bottom Channel																																													
Ground	Ground	Ground	251-350 nsec	Add Delay to Bottom Channel																																													
<b>P1A-3G, P1A-3H, P1A-3J</b>	<p><b>SDI PROGRAM INPUTS:</b></p> <p>The SDI program inputs are used to identify the system number in the installation. The inputs use ground/open logic levels. The SDI Common (pin P1A-3J) can be used to supply a ground.</p> <table border="1" data-bbox="326 1209 1078 1415"> <thead> <tr> <th colspan="2">Program Pin</th> <th rowspan="2">Definition</th> </tr> <tr> <th>P1A-3G</th> <th>P1A-3H</th> </tr> </thead> <tbody> <tr> <td>Open</td> <td>Open</td> <td>Not Applicable (SDI = 00)</td> </tr> <tr> <td>Open</td> <td>Ground</td> <td>LRU System #1 (SDI = 01)</td> </tr> <tr> <td>Ground</td> <td>Open</td> <td>LRU System #2 (SDI = 10)</td> </tr> <tr> <td>Ground</td> <td>Ground</td> <td>LRU System #3 (SDI = 11)</td> </tr> </tbody> </table>	Program Pin		Definition	P1A-3G	P1A-3H	Open	Open	Not Applicable (SDI = 00)	Open	Ground	LRU System #1 (SDI = 01)	Ground	Open	LRU System #2 (SDI = 10)	Ground	Ground	LRU System #3 (SDI = 11)																															
Program Pin		Definition																																															
P1A-3G	P1A-3H																																																
Open	Open	Not Applicable (SDI = 00)																																															
Open	Ground	LRU System #1 (SDI = 01)																																															
Ground	Open	LRU System #2 (SDI = 10)																																															
Ground	Ground	LRU System #3 (SDI = 11)																																															
<b>P1A-4A THRU P1A-4J</b>	<p><b>ARINC 565 ANALOG AIR DATA COMPUTER #1 INPUTS:</b></p> <p>These input pins allow for altitude information from an Analog Synchro Altitude Interface to be connected to the transponder. The standards for this interface are defined in ARINC 565, "Subsonic Air Data System".</p>																																																



**SYSTEM DESCRIPTION AND INSTALLATION MANUAL**  
TCAS 3000 Traffic Alert and Collision Avoidance System

**Table 4–8. XS–950 Data Link Transponder Interface Descriptions (cont)**

Connector Pin Designation	Functional Description																																																		
<b>P1A–5A, P1A–5B, P1A–5C, P1A–5D</b>	<p><b>MAXIMUM TRUE AIRSPEED PROGRAM INPUTS:</b> The Maximum True Airspeed inputs are used for strapping the maximum cruise airspeed capability of the aircraft. The inputs use ground/open logic levels. The Max True Airspeed Common (pin P1A–5D) can be used to supply a ground.</p> <table border="1" data-bbox="431 541 1390 863"> <thead> <tr> <th colspan="4" data-bbox="431 541 1390 569">Program Pin</th> <th data-bbox="431 569 1390 596"></th> </tr> <tr> <th data-bbox="431 596 537 623">P1A–5A</th> <th data-bbox="537 596 675 623">P1A–5B</th> <th data-bbox="675 596 878 623">P1A–5C</th> <th data-bbox="878 596 1390 623"></th> <th data-bbox="431 623 1390 651">Definition</th> </tr> </thead> <tbody> <tr> <td data-bbox="431 651 537 678">Open</td> <td data-bbox="537 651 675 678">Open</td> <td data-bbox="675 651 878 678">Open</td> <td data-bbox="878 651 1390 678"></td> <td data-bbox="431 678 1390 705">No Maximum Airspeed Available</td> </tr> <tr> <td data-bbox="431 705 537 732">Ground</td> <td data-bbox="537 705 675 732">Open</td> <td data-bbox="675 705 878 732">Open</td> <td data-bbox="878 705 1390 732"></td> <td data-bbox="431 732 1390 760">Maximum Airspeed ≤75 Knots</td> </tr> <tr> <td data-bbox="431 760 537 787">Open</td> <td data-bbox="537 760 675 787">Ground</td> <td data-bbox="675 760 878 787">Open</td> <td data-bbox="878 760 1390 787"></td> <td data-bbox="431 787 1390 814">Maximum Airspeed &gt;75 and ≤150 Knots</td> </tr> <tr> <td data-bbox="431 814 537 842">Ground</td> <td data-bbox="537 814 675 842">Ground</td> <td data-bbox="675 814 878 842">Open</td> <td data-bbox="878 814 1390 842"></td> <td data-bbox="431 842 1390 869">Maximum Airspeed &gt;150 and ≤300 Knots</td> </tr> <tr> <td data-bbox="431 869 537 896">Open</td> <td data-bbox="537 869 675 896">Open</td> <td data-bbox="675 869 878 896">Ground</td> <td data-bbox="878 869 1390 896"></td> <td data-bbox="431 896 1390 924">Maximum Airspeed &gt;300 and ≤600 Knots</td> </tr> <tr> <td data-bbox="431 924 537 951">Ground</td> <td data-bbox="537 924 675 951">Open</td> <td data-bbox="675 924 878 951">Ground</td> <td data-bbox="878 924 1390 951"></td> <td data-bbox="431 951 1390 978">Maximum Airspeed &gt;600 and ≤1200 Knots</td> </tr> <tr> <td data-bbox="431 978 537 1005">Open</td> <td data-bbox="537 978 675 1005">Ground</td> <td data-bbox="675 978 878 1005">Ground</td> <td data-bbox="878 978 1390 1005"></td> <td data-bbox="431 1005 1390 1033">Maximum Airspeed &gt;1200 Knots</td> </tr> <tr> <td data-bbox="431 1033 537 1060">Ground</td> <td data-bbox="537 1033 675 1060">Ground</td> <td data-bbox="675 1033 878 1060">Ground</td> <td data-bbox="878 1033 1390 1060"></td> <td data-bbox="431 1060 1390 1087">Not Assigned</td> </tr> </tbody> </table>	Program Pin					P1A–5A	P1A–5B	P1A–5C		Definition	Open	Open	Open		No Maximum Airspeed Available	Ground	Open	Open		Maximum Airspeed ≤75 Knots	Open	Ground	Open		Maximum Airspeed >75 and ≤150 Knots	Ground	Ground	Open		Maximum Airspeed >150 and ≤300 Knots	Open	Open	Ground		Maximum Airspeed >300 and ≤600 Knots	Ground	Open	Ground		Maximum Airspeed >600 and ≤1200 Knots	Open	Ground	Ground		Maximum Airspeed >1200 Knots	Ground	Ground	Ground		Not Assigned
Program Pin																																																			
P1A–5A	P1A–5B	P1A–5C		Definition																																															
Open	Open	Open		No Maximum Airspeed Available																																															
Ground	Open	Open		Maximum Airspeed ≤75 Knots																																															
Open	Ground	Open		Maximum Airspeed >75 and ≤150 Knots																																															
Ground	Ground	Open		Maximum Airspeed >150 and ≤300 Knots																																															
Open	Open	Ground		Maximum Airspeed >300 and ≤600 Knots																																															
Ground	Open	Ground		Maximum Airspeed >600 and ≤1200 Knots																																															
Open	Ground	Ground		Maximum Airspeed >1200 Knots																																															
Ground	Ground	Ground		Not Assigned																																															
<b>P1A–5E, 5F</b>	<p><b>ARINC 429 TX COORDINATION BUS INPUT: (P1A–5E [A], P1A–5F [B])</b> Two high speed ARINC 429 busses (100K bits/second nominal) are provided to interface between the transponder and a TCAS computer unit. The standards for this interface are defined in ARINC Characteristic 735, “Traffic Alert and Collision Avoidance System”.</p>																																																		
<b>P1A–5G, 5H</b>	<p><b>ARINC 429 XT COORDINATION BUS OUTPUT: (P1A–5G [A], P1A–5H [B])</b> See pins P1A–5E, 5F.</p>																																																		
<b>P1A–5J</b>	<p><b>AIR / GROUND #2 DISCRETE INPUT:</b> This pin and AIR / GROUND #1 Discrete Input (pin P1A–5K) provide a method for the transponder to automatically determine the Air/Ground status of the aircraft. The status is used in replies to Mode S interrogations and to inhibit replies to certain types of interrogations. Both inputs use ground/open logic, where a Ground specifies an “On the Ground” condition and an Open specifies an “In the Air” condition.  When this pin is connected to the Air/Ground Relay (Squat Switch), the transponder will not reply to ATCRBS, ATCRBS/Mode S All Call, or Mode S All Call when the input is set for “On the Ground”. This input should be connected to the Air/Ground Relay for normal operation.</p>																																																		
<b>P1A–5K</b>	<p><b>AIR / GROUND #1 DISCRETE INPUT:</b> See pin P1A–5J.  When this pin is connected to the Air/Ground Relay (Squat Switch), the transponder replies to all types of interrogations irregardless of the state of the input. This input allows the transponder to reply during a ramp test.</p>																																																		
<b>P1A–6A, 6B</b>	<p><b>FMC #1/General In #2</b> This differential pair input supports common existing FMC configurations where flight ID is available on the FMC General Purpose output bus but the other Enhanced data is only available on a display bus.</p>																																																		



**SYSTEM DESCRIPTION AND INSTALLATION MANUAL**  
TCAS 3000 Traffic Alert and Collision Avoidance System

**Table 4–8. XS–950 Data Link Transponder Interface Descriptions (cont)**

Connector Pin Designation	Functional Description
<b>P1A–6C, 6D</b>	<p><b>ARINC 615 AIRBORNE DATA LOADER BUS INPUT: (P1A–6C [A], P1A–6D [B])</b></p> <p>The Airborne Data Loader interface consists of two high speed ARINC 429 busses (100K bits/second nominal) and a ground/open logic discrete (pin P1A–6G). The interface allows for operational transponder software to be loaded into the unit through an onboard data loader. The standards for this interface are defined in ARINC 615 “Airborne Computer High Speed Data Loader”.</p>
<b>P1A–6E, 6F</b>	<p><b>ARINC 615 AIRBORNE DATA LOADER BUS OUTPUT: (P1A–6E [A], P1A–6F [B])</b></p> <p>See pins P1A–6C, 6D</p>
<b>P1A–6G</b>	<p><b>ADL INPUT LINK A DISCRETE INPUT:</b></p> <p>See pins P1A–6C, 6D</p>
<b>P1A–6H, 6J</b>	<p><b>ARINC 575 AIR DATA COMPUTER #1 INPUT: (P1A–6H [A], P1A–6J [B])</b></p> <p>This differential pair input is a low speed ARINC 575 bus (12.5K bits/second nominal) that can be used to input altitude information from an ARINC 575 Air Data System. The standards for this interface are defined in ARINC Characteristic 575, “Subsonic Air Data System (Digital) DADS”.</p>
<b>P1A–6K</b>	<p><b>SINGLE / DUAL ANTENNA PROGRAM INPUT:</b></p> <p>This pin allows for installation of the transponder in a system with a single bottom mounted antenna or dual top and bottom mounted antennas. The input uses ground/open logic as follows:</p> <p style="padding-left: 40px;">Ground = Single Bottom Mounted Antenna Configuration Open = Diversity Antenna Configuration</p>
<b>P1A–7A, 7B</b>	<p><b>ARINC 429 CONTROL DATA PORT A BUS INPUT: (P1A–7A [A], P1A–7B [B])</b></p> <p>The control panel data can be input into the transponder on either of two low speed ARINC 429 busses. (Ports A and B). The control data is contained in labels 013, 015, and 016. The port is selected by the CONTROL DATA PORT SELECT Discrete Input (pin P1A–7D).</p>
<b>P1A–7D</b>	<p><b>CONTROL DATA PORT SELECT INPUT:</b></p> <p>See pins P1A–7A, 7B.</p> <p>This discrete input is used to select which port is used to input control data to the transponder. This input uses a ground/open logic as follows:</p> <p style="padding-left: 40px;">Ground Specifies Port A Open Specifies Port B</p>
<b>P1A–7E, 7F</b>	<p><b>ARINC 429 CONTROL DATA PORT B BUS INPUT: (P1A–7E [A], P1A–7F [B])</b></p> <p>See pins P1A–7A, 7B.</p>
<b>P1A–7G</b>	<p><b>STANDBY / ON DISCRETE INPUT:</b></p> <p>This discrete input is connected to the Control Panel STANDBY/ON output. The input selects the active or standby status of the transponder. A ground causes the transponder to be in standby, and an open causes the transponder to be active.</p>



**SYSTEM DESCRIPTION AND INSTALLATION MANUAL**  
TCAS 3000 Traffic Alert and Collision Avoidance System

**Table 4–8. XS–950 Data Link Transponder Interface Descriptions (cont)**

Connector Pin Designation	Functional Description
P1A–7H, 7J	<p><b>ARINC 429 ADC #1 BUS INPUT: (P1A–7H [A], P1A–7J [B])</b></p> <p>The altitude information for the transponder can be obtained from an ARINC 706 Air Data System through two low speed ARINC 429 data busses. The standards for this interface are defined in ARINC Characteristic 706, “Mark 5 Subsonic Air Data System”.</p> <p>This differential pair input is a low speed ARINC 429 bus that inputs uncorrected pressure altitude (ARINC label 203) from an altitude source. Also see pins P1B–5A, 5B.</p>
P1A–71	<p><b>TOP ANTENNA RF INPUT:</b></p> <p>RF input from top antenna.</p>
P1B–1A THRU P1B–3E	<p><b>MODE S ADDRESS INPUTS:</b></p> <p>The Mode S Address is a unique 24–bit code assigned to each aircraft. Pins P1B–1A thru P1B–3E are used to program this 24–bit binary number. The inputs must be set according to this binary number representation. Each binary <b>1</b> represents a Grounded pin and each binary <b>0</b> represents an Open pin. Pin P1B–1A represents the most significant bit (MSB) of the binary number and pin P1B–3D represents the least significant bit (LSB) of the binary number.</p> <p><b>NOTE:</b> An address of all 0’s or all 1’s is an illegal address, and can cause the aircraft to be invisible to TCAS II equipped aircraft in flight. Never use an illegal address for an installed system.</p>
P1B–3H	<p><b>FUNCTIONAL TEST DISCRETE INPUT:</b></p> <p>This discrete input is used to put the transponder in a functional test mode. The functional test that is performed by the transponder is equivalent to a test that is initiated from the control panel. The input uses ground/open logic as follows:</p> <p style="padding-left: 40px;">Ground = Initiate Functional Test Open = Normal Operation</p>
P1B–3J	<p><b>ALTITUDE COMPARISON FAIL DISCRETE OUTPUT:</b></p> <p>This discrete output annunciates a comparison failure in the altitude data for the transponder if Gillham altitude data is selected. The output annunciates a failure if the two altitude sources are not within 500 feet.</p> <p>The output drives a ground logic threshold (voltage of less than 3.0 V dc) when the altitude is valid, and an open logic threshold (resistance is greater than 100K ohms to unit ground) when a failure has occurred. The output is capable of sinking 200 mA of current.</p>
P1B–3K	<p><b>XPDR FAIL DISCRETE OUTPUT #1:</b></p> <p>This discrete output is set to annunciate an internal transponder failure or that the Mode S address is illegal (All <b>0</b>’s or <b>1</b>’s). The output will source a voltage of greater than 5.0 V dc at 100 mA of current when a failure has occurred, and an open circuit (resistance of greater than 100k ohms to unit ground) when the transponder is operating normally. The output contains diode isolation. Connect this pin to the Control Panel XPDR FAIL #1 input.</p>
P1B–4A THRU P1B–4K, AND P1B–5K	<p><b>ENCODING ALTIMETER #1 INPUTS:</b></p> <p>First of two Encoding Altimeter interfaces. See pins P1A–1A thru 4K and P1A–2K.</p>





**SYSTEM DESCRIPTION AND INSTALLATION MANUAL**  
TCAS 3000 Traffic Alert and Collision Avoidance System

**Table 4–8. XS–950 Data Link Transponder Interface Descriptions (cont)**

Connector Pin Designation	Functional Description
<b>P1B–5A, 5B</b>	<b>ARINC 429 AIR DATA COMPUTER #2 BUS INPUT: (P1B–5A [A], P1B–5B [B])</b> Second ARINC 429 Air Data Computer bus input. See pins P1A–7H, 7J.
<b>P1B–5C, 5D</b>	<b>ARINC 575 AIR DATA COMPUTER #2 BUS INPUT: (P1B–5C [A], P1B–5D [B])</b> Second ARINC 575 Air Data Computer bus input. See pins P1A–6H, 6J.
<b>P1B–5E, 5F</b>	<b>ARINC 429 COMM A/B TO ADLP BUS OUTPUT: (P1B–5E [A], P1B–5F [B])</b> See pins P1A–2A, 2B.
<b>P1B–5G</b>	<b>Extended Squitter Disable</b> This input is used to disable all Extended Squitter functions: Ground = All functions disabled Open = All functions enabled
<b>P1B–5H</b>	<b>MODE S DATA LINK PROGRAM INPUT:</b> This program input specifies if the transponder is connected to an Airborne Data Link Processor (ADLP) Unit. The input uses ground/open logic as follows: Ground = ADLP is Installed Open = ADLP is not installed
<b>P1B–5J</b>	<b>ANTENNA BITE PROGRAM INPUT:</b> This program input specifies if the transponder is to perform a built–in test to the antenna subsystem. The transponder performs a continuity check of the antenna to make sure it is not an open circuit. The input uses ground/open logic as follows: Ground = Enables Antenna Subsystem Test Open = Disables Antenna Subsystem Test
<b>P1B–6A, 6B</b>	<b>ARINC 429 MAINTENANCE DATA BUS INPUT: (P1B–6A [A], P1B–6B [B])</b> Two low speed ARINC 429 busses (12.5K bits/second nominal) are provided to interface between the transponder and an onboard maintenance system. The maintenance computer interface is designed to work with all airframe models and types.
<b>P1B–6C, 6D</b>	<b>ARINC 429 MAINTENANCE DATA BUS OUTPUT: (P1B–6C [A], P1B–6D [B])</b> See pins P1B–6A, 6B.
<b>P1B–6E</b>	<b>AIR DATA SOURCE SOURCE SELECT DISCRETE INPUT:</b> The transponder contains dual inputs for all types of altitude sources. This discrete input specifies which of the two inputs are used to obtain altitude information. Ground = Altitude Source No. 2 Open = Altitude Source No. 1



**SYSTEM DESCRIPTION AND INSTALLATION MANUAL**  
TCAS 3000 Traffic Alert and Collision Avoidance System

**Table 4-8. XS-950 Data Link Transponder Interface Descriptions (cont)**

Connector Pin Designation	Functional Description																								
<b>P1B-6F, P1B-6G, P1B-6H</b>	<p><b>ALTITUDE TYPE SELECT PROGRAM INPUT:</b> The Altitude Type Select program pins are used to configure the transponder for the type of altitude source that is connected to it. The inputs use ground/open logic. The Altitude Type Select Common (pin P1B-6H) can be used to supply a ground.</p> <table border="0"> <thead> <tr> <th align="center" colspan="3">Program Pin</th> <th></th> </tr> <tr> <th align="center">P1B-6F</th> <th align="center">P1B-6G</th> <th></th> <th align="center">Definition</th> </tr> </thead> <tbody> <tr> <td align="center">Ground</td> <td align="center">Ground</td> <td></td> <td>Selects Gillham Altitude Source</td> </tr> <tr> <td align="center">Ground</td> <td align="center">Open</td> <td></td> <td>Selects ARINC 575 Altitude Source</td> </tr> <tr> <td align="center">Open</td> <td align="center">Ground</td> <td></td> <td>Selects ARINC 407 Synchro Altitude Source</td> </tr> <tr> <td align="center">Open</td> <td align="center">Open</td> <td></td> <td>Selects ARINC 429 Altitude Source</td> </tr> </tbody> </table>	Program Pin				P1B-6F	P1B-6G		Definition	Ground	Ground		Selects Gillham Altitude Source	Ground	Open		Selects ARINC 575 Altitude Source	Open	Ground		Selects ARINC 407 Synchro Altitude Source	Open	Open		Selects ARINC 429 Altitude Source
Program Pin																									
P1B-6F	P1B-6G		Definition																						
Ground	Ground		Selects Gillham Altitude Source																						
Ground	Open		Selects ARINC 575 Altitude Source																						
Open	Ground		Selects ARINC 407 Synchro Altitude Source																						
Open	Open		Selects ARINC 429 Altitude Source																						
<b>P1B-7A THRU P1B-7J</b>	<p><b>ARINC 565 ANALOG AC AIR DATA COMPUTER #2 INPUTS:</b> Second ARINC 565 Analog AC Air Data Computer Input. See pins P1A-4A Thru 4J.</p>																								
<b>P1B-7I</b>	<p><b>BOTTOM ANTENNA RF INPUT:</b> RF input from bottom antenna.</p>																								
<b>P1C-1</b>	<p><b>XPDR 115 V ac INPUT POWER: (H)</b> This pin along with the XPDR 115 V ac RETURN line (pin P1C-7) provides the 115 V ac power requirements for the transponder. <b>NOTE:</b> Only -10XXX thru -54XXX transponders accept 115 V ac, 400 Hz input power. If the 115 V ac version is used, the power should be connected through a 5 amp circuit breaker, and the pins for the 28 V dc input (P1C-10 and P1C-3) should be left unconnected.</p>																								
<b>P1C-3</b>	<p><b>XPDR +28 V dc RETURN: (L)</b> See pin P1C-10.</p>																								
<b>P1C-4</b>	<p><b>XPDR OFF (NO) INPUT:</b> This discrete input is used to turn the transponder power supply OFF. It should not be connected in aircraft installations.</p>																								
<b>P1C-6</b>	<p><b>FAN +28 V dc OUTPUT: (+)</b> The 28 V dc version of the transponder can control an externally mounted 28 volt fan to provide cooling air for the transponder. The Fan +28 V dc Output (P1C-6) should be connected to the positive input of the fan, and the Fan Return (NO) Output (P1C-9) should be connected to the negative input of the fan. The output has the capability to drive a fan that draws up to 200 mA of current. The fan is turned on when the internal transponder temperature rises above 30 degrees centigrade. In the 115 V ac version of the transponder, the outputs are not used.</p>																								
<b>P1C-7</b>	<p><b>XPDR 115 V ac RETURN: (C)</b> See pin P1C-1.</p>																								
<b>P1C-8</b>	<p><b>SIGNAL GROUND INPUT:</b> Connect to Aircraft Signal Ground.</p>																								



**SYSTEM DESCRIPTION AND INSTALLATION MANUAL**  
TCAS 3000 Traffic Alert and Collision Avoidance System

**Table 4-8. XS-950 Data Link Transponder Interface Descriptions (cont)**

Connector Pin Designation	Functional Description
P1C-9	<b>FAN RETURN (NO): (-)</b> See pin P1C-6.
P1C-10	<b>XPDR +28 V dc INPUT POWER: (H)</b> This pin along with the +28 V dc RETURN line (P1C-3) provide the 28 V dc power requirements for the transponder. <b>NOTE:</b> Only -55XXX thru -99XXX transponders accept 28 V dc input power. If the 28 V dc version is used, the power should be connected through an 8 amp circuit breaker, and the pins for the 115 V ac input (P1C-1 and P1C-7) should be left unconnected.
P1C-11	<b>CHASSIS GROUND INPUT:</b> Connect to aircraft frame.
P1C-12, P1C-13	<b>MUTUAL SUPPRESSION BUS INPUT/OUTPUT:</b> L-Band suppression coax must be RG-142 or equivalent coaxial cable. P1C-12 and P1C-13 are connected internally. Connection to only one pin is required.
<b>The interface descriptions that follow are for the 53-pin ARINC 615 Portable Data Loader connector J1 mounted on the front panel of the transponder. These descriptions are used to make up the cable that is used to interface between the transponder and the ARINC 615 Data Loader or a RS-232 PC Serial Port.</b>	
J1-1, 2	<b>XPDR ARINC 429 PDL BUS INPUT: (J1-1 [A], J1-2 [B])</b> This differential pair input is a high speed ARINC 429 bus (100K bits/second nominal) is used to input data from the data loader to the transponder. The standards for this interface are defined in ARINC 615 "Airborne Computer High Speed Data Loader". These pins should be connected to pins 1 and 2 of the PDL cable interface.
J1-5	<b>INPUT BUS SHIELD:</b> The shields from the input bus (J1-1, 2) should be connected to this pin.
J1-8, 9	<b>XPDR ARINC 429 PDL BUS OUTPUT: (J1-8 [A], J1-9 [B])</b> This differential pair output is a high speed ARINC 429 bus (100K bits/second nominal) used to output data from the transponder to the data loader. The standards for this interface are defined in ARINC 615 "Airborne Computer High Speed Data Loader". These pins should be connected to pins 8 and 9 of the PDL cable interface.
J1-16	<b>OUTPUT BUS SHIELD:</b> The shields from the output bus (J1-8, 9) should be connected to this pin.
J1-18	<b>PDL LINK A:</b> Connect this pin to pin 18 of the PDL cable interface.
J1-19	<b>PDL LINK B:</b> Connect this pin to pin 19 of the PDL cable interface.



**SYSTEM DESCRIPTION AND INSTALLATION MANUAL**  
TCAS 3000 Traffic Alert and Collision Avoidance System

**Table 4–8. XS–950 Data Link Transponder Interface Descriptions (cont)**

Connector Pin Designation	Functional Description												
<b>J1–20, 22</b>	<p><b>115 V ac POWER OUTPUT: (J1–20 [H], J1–22 [C])</b></p> <p>These power output pins provide the 115 V ac operating power for the data loader.</p> <p><b>NOTE:</b> Only the 115 V ac version transponders provide this output. If a 28 V dc version transponder is installed, either the data loader must be able to operate from 28 V dc or the data loader 115 V ac input power must be connected to a source external to the transponder.</p> <p>The 115 V ac (H) and 115 V ac (C) should be shielded or twisted and shielded with an insulating jacket over the shield. The shield should be connected to chassis ground (pin 21).</p>												
<b>J1–21</b>	<p><b>CHASSIS GROUND:</b></p> <p>Connect 115 V ac power shields to this pin.</p>												
<b>J1–37, 38</b>	<p><b>28 V dc POWER OUTPUT: (J1–37 [HI], J1–38 [LO])</b></p> <p>These power output pins provide the 28 V dc operating power for the data loader. These pins are used only if the data loader operates from 28 V dc.</p>												
<b>J1–40 J1–41 J1–48,49</b>	<p><b>RS–232 PDL INPUT: RS–232 PDL OUTPUT LOGIC COMMON (Gnd)</b></p> <p>These pins would be connected to an RS–232 Serial Port as follows. Most RS–232 Serial Ports use either a 9 pin RS–232 (COM) connector or a 25 pin RS–232 (COM) connector.</p> <table border="1" data-bbox="435 1129 1490 1312"> <thead> <tr> <th data-bbox="435 1129 760 1192">ARINC 615 CONNECTOR PIN</th> <th data-bbox="760 1129 1133 1192">PC COM1 OR COM2 9 PIN CONNECTOR</th> <th data-bbox="1133 1129 1490 1192">PC COM1 OR COM2 25 PIN CONNECTOR</th> </tr> </thead> <tbody> <tr> <td data-bbox="435 1213 760 1245">40</td> <td data-bbox="760 1213 1133 1245">PC TX (pin 3)</td> <td data-bbox="1133 1213 1490 1245">PC TX (pin 2)</td> </tr> <tr> <td data-bbox="435 1245 760 1276">41</td> <td data-bbox="760 1245 1133 1276">PC RX (pin 2)</td> <td data-bbox="1133 1245 1490 1276">PC RX (pin 3)</td> </tr> <tr> <td data-bbox="435 1276 760 1308">48 or 49</td> <td data-bbox="760 1276 1133 1308">Ground (pin 5)</td> <td data-bbox="1133 1276 1490 1308">Ground (pin 7)</td> </tr> </tbody> </table> <p><b>NOTE:</b> When using a RS–232 interface, transponder pin J1–18 (Link A) and pin J1–19 (Link B) must be connected (tied together) to do a software upload. The pins should be open to verify the software status.</p>	ARINC 615 CONNECTOR PIN	PC COM1 OR COM2 9 PIN CONNECTOR	PC COM1 OR COM2 25 PIN CONNECTOR	40	PC TX (pin 3)	PC TX (pin 2)	41	PC RX (pin 2)	PC RX (pin 3)	48 or 49	Ground (pin 5)	Ground (pin 7)
ARINC 615 CONNECTOR PIN	PC COM1 OR COM2 9 PIN CONNECTOR	PC COM1 OR COM2 25 PIN CONNECTOR											
40	PC TX (pin 3)	PC TX (pin 2)											
41	PC RX (pin 2)	PC RX (pin 3)											
48 or 49	Ground (pin 5)	Ground (pin 7)											
<b>J1–50 J1–51 J1–52 J1–53</b>	<p><b>PDL FUNCTION DISCRETE #1 INPUT: PDL FUNCTION DISCRETE #2 INPUT: PDL FUNCTION DISCRETE #3 INPUT: PDL FUNCTION DISCRETE #4 INPUT:</b></p> <p>These pins are used to receive discrete functional information from the data loader. These pins should be connected to the PDL cable interface.</p>												



**SYSTEM DESCRIPTION AND INSTALLATION MANUAL**  
TCAS 3000 Traffic Alert and Collision Avoidance System

**Table 4-9. RCZ-852 Diversity Mode S Transponder Interface Descriptions**

Connector Pin Designation	Functional Description
J1-1, 2	<b>XPDR +28 V FAN PWR &amp; +28V FAN RTN: (J1-1 LOW, J1-2 HIGH)</b> The fan discrete outputs supply a switched, filtered +28 volts for a dc fan. The RCZ-852 Transponder has an internal fan built into the unit, so external cooling is not required. Pins J1-1 and J1-2 should not be connected.
J1-3	<b>MUTUAL SUPPRESSION BUS I/O:</b> This bus is a single conductor, shielded bidirectional line that connects to all aircraft L-Band equipment. It is used to desensitize the associated receiver inputs while transmitting.
J1-7	<b>XPDR +28 V RTN:</b> See pins 8, 9.
J1-8 J1-9	<b>XPDR +28 V PWR:</b> These pins along with there return lines (J1-7 and J1-20) provide the 28 volt power requirements for the transponder.
J1-11	<b>PROGRAM ENABLE INPUT:</b> Bench test function. Do not connect this pin in aircraft installations.
J1-12	<b>XPDR RS232 TX OUTPUT:</b> Bench test function. Do not connect this pin in aircraft installations.
J1-17, J1-18 J1-19, J1-21	<b>DC GROUND INPUT:</b> To be connected to aircraft dc ground.
J1-23	<b>XPDR VALID (PO) OUTPUT:</b> This discrete outputs the status of the transponder continuous monitor tests. It is the same as the XPDR VALID (NO) output (J1-100) except the discrete is a positive/open logic. A +28 V dc (200 mA maximum) is provided when the transponder is operational and an active transponder mode is selected. An Open (>100K ohms resistance to ground) output is provided when the transponder has failed or the standby mode is selected.
J1-24	<b>XPDR RS232 RX INPUT:</b> Bench test function. Do not connect this pin in aircraft installations.
J1-25	<b>PROGRAM +15 V OUTPUT:</b> Bench test function. Do not connect this pin in aircraft installations.
J1-26, 27	<b>XPDR TO TCAS ARINC 429 BUS OUTPUT: (J1-26 [A], J1-27 [B])</b> This differential pair output is a high speed ARINC 429 bus (100K bits/second nominal) that sends data to the TCAS computer unit. The data bus conforms to the ARINC 718-A and ARINC 735 standards for TCAS to transponder interface.
J1-28, 29	<b>XPDR TO DLP A/B ARINC 429 BUS OUTPUT: (J1-28 [A], J1-29[B])</b> This differential pair output is a high speed ARINC 429 bus (100K bits/second nominal) that sends data to an airborne data link processor (ADLP) system. The data bus is used to transfer COMM-A and COMM-B messages between the two systems and conforms to the ARINC 718-A standard for ADLP to transponder interface.



**SYSTEM DESCRIPTION AND INSTALLATION MANUAL**  
TCAS 3000 Traffic Alert and Collision Avoidance System

**Table 4–9. RCZ–852 Diversity Mode S Transponder Interface Descriptions (cont)**

Connector Pin Designation	Functional Description
J1–30,31	<p><b>XPDR TO DLP C/D ARINC 429 BUS OUTPUT: (J1–30 [A], J1–31 [B])</b></p> <p>This differential pair output is a high speed ARINC 429 bus (100K bits/second nominal) that sends data to an airborne data link processor (ADLP) system. The data bus is used to transfer COMM–C and COMM–D messages between the two systems and conforms to the ARINC 718–A standard for ADLP to transponder interface.</p>
J1–32, 33	<p><b>ADC1 TO XPDR ARINC 429/575 BUS INPUT: (J1–32 [A], J1–33 [B])</b></p> <p>This differential pair input is a low speed ARINC 429 or 575 bus that inputs uncorrected pressure altitude (ARINC label 203) from an altitude source. The input accepts either ARINC 429 or 575 data format, which is selected by the altitude source straps (W33, W34) on the Strap Assembly. The ALT SRC SEL2 (NO) discrete, pin 60, selects either ADC1 or ADC2.</p>
J1–34, 35	<p><b>CTL1 TO XPDR ARINC 429 BUS INPUT: (J1–34 [A], J1–35 [B])</b></p> <p>The transponder can receive data from the control panel(s) on the CTL1 TO XPDR and CTL2 TO XPDR data busses. The bus used, is selected by the CTL SRC SEL1 (NO) DISCRETE. See pin 61. The data bus not selected will not be processed. These differential pair inputs are low speed ARINC 429 busses (12.5K bits/second nominal) that transmits tuning information from the control panel to the transponder. The transponder expects to receive ARINC labels 016 and 031 at an update rate of 100 to 200 milliseconds. Also see CTL2 TO XPDR ARINC 429 bus input (pins 48 and 49).</p>
J1–40, 41	<p><b>TCAS TO XPDR ARINC 429 BUS INPUT: (J1–40 [A], J1–41 [B])</b></p> <p>This differential pair input is a high speed ARINC 429 bus (100K bit/second nominal) that receives data from a TCAS computer unit. The data bus conforms to the ARINC 718–A and ARINC 735 standards for TCAS to transponder interface.</p>
J1–42, 43	<p><b>DLP A/B TO XPDR ARINC 429 BUS INPUT: (J1–42 [A], J1–43 [B])</b></p> <p>This differential pair input is a high speed ARINC 429 bus (100K bits/second nominal) that receives data from an airborne data link processor (ADLP) system. The data bus is used to transfer COMM–A and COMM–B messages between the two systems and conforms to the ARINC 718–A standard for ADLP to transponder interface.</p>
J1–44, 45	<p><b>DLP C/D TO XPDR ARINC 429 BUS INPUT: (J1–44 [A], J1–45 [B])</b></p> <p>This differential pair input is a high speed ARINC 429 bus (100K bits/second nominal) that receives data from an airborne data link processor (ADLP) system. The data bus is used to transfer COMM–C and COMM–D messages between the two systems and conforms to the ARINC 718–A standard for ADLP to transponder interface.</p>
J1–46,47	<p><b>ADC2 TO XPDR ARINC 429/575 BUS INPUT: (J1–46 [A], J1–47 [B])</b></p> <p>See pins J1–32, 33</p>
J1–48, 49	<p><b>CTL2 TO XPDR ARINC 429 BUS INPUT: (J1–48 [A], J1–49 [B])</b></p> <p>See pins J1–34, 35</p>
J1–50, 51	<p><b>XPDR TO CTL ARINC 429 BUS OUTPUT: (J1–50 [A], J1–51 [B])</b></p> <p>This differential pair output is a low speed ARINC 429 bus (12.5K bits/second) that transmits control panel input data back to the control panel for verification purposes. These output pins are connected only on some Collins control panels that require feedback from the transponder to make sure it is operating properly.</p>



**SYSTEM DESCRIPTION AND INSTALLATION MANUAL**  
TCAS 3000 Traffic Alert and Collision Avoidance System

**Table 4–9. RCZ–852 Diversity Mode S Transponder Interface Descriptions (cont)**

Connector Pin Designation	Functional Description
<b>J1–53 thru 58, J1–67 thru 71</b>	<p><b>ENCODING ALTIMETER NO.1 ELEVEN BIT INPUT:</b> Transponder input from Encoding Altimeter No. 1. These eleven lines from the altitude encoder comprise an 11–bit word representative of the aircraft altitude.</p>
<b>J1–59</b>	<p><b>ALT COMP ENA (NO) DISCRETE INPUT:</b> This discrete input enables or disables altitude comparison when dual Gillham altitude sources are selected via the ALTITUDE SOURCE strap. If comparison is enabled (J1–59 Grounded), the two altitude sources (ENC ALT1 and ENC ALT2) are compared, and are considered valid if they are within 500 feet. If the altitude comparison is enabled and it fails, the altitude data is considered invalid in Mode S replies and altitude data sent to TCAS. If comparison is disabled (J1–59 Open), only the selected altitude source is used. This discrete has no effect if ARINC 429 or 575 altitude sources are used.</p> <p><b>NOTE:</b> For installations with TCAS that use Gillham encoding altimeter sources, two encoding altimeter sources must be used, and pin J1–59 must be enabled (Grounded).</p>
<b>J1–60</b>	<p><b>ALT SRC SEL2 (NO) DISCRETE INPUT:</b> This discrete input allows selection of one of two altitude sources. An Open causes the transponder to use altitude source No.1, and a Ground causes the transponder to use altitude source No.2. The altitude data sent to TCAS and used for transponder replies is derived from the selected source.</p>
<b>J1–61</b>	<p><b>CTL SRC SEL1 (NO) DISCRETE INPUT:</b> This discrete input is used to select one of two ARINC 429 control tuning ports. A Ground on this pin causes the transponder to use CTL1 TO XPDR bus for tuning data, and an Open causes the transponder to use CTL2 TO XPDR bus for tuning data. The input is used only when the transponder tuning source is an ARINC 429 source in a stand–alone transponder system. When an RSB tuning source is used, the input is ignored.</p>
<b>J1–64, 65</b>	<p><b>FMS TO XPDR ARINC 429 BUS INPUT: (J1–64 [A], J1–65 [B])</b> This differential pair input is a low speed ARINC 429 bus (12.5K bits/second nominal) that receives basic transponder control data (label 031) and AIS flight ID (labels 233, 234, 235, and 236) from a Flight Management System (FMS).</p>
<b>J1–72</b>	<p><b>XPDR STANDBY (NO) INPUT:</b> This discrete input is connected to the Control Panel STANDBY/ON output. The input selects the active or standby status of the transponder. A ground causes the transponder to be in Standby, and an Open causes the transponder to be active. The input is used only when the transponder tuning source is an ARINC 429 source in a stand–alone transponder system. When an RCB tuning source is used, the input is ignored.</p> <p><b>NOTE:</b> If using a Collins CTL–92 Controller, this pin is not used.</p>





**SYSTEM DESCRIPTION AND INSTALLATION MANUAL**  
TCAS 3000 Traffic Alert and Collision Avoidance System

**Table 4–9. RCZ–852 Diversity Mode S Transponder Interface Descriptions (cont)**

Connector Pin Designation	Functional Description																																																		
<b>J1–73</b>	<p><b>SQUAT SWITCH 1 (NO) DISCRETE INPUT:</b></p> <p>This discrete input is used in conjunction with SQUAT SWITCH 2 discrete input (pin 75). The squat switch inputs tell the transponder if the aircraft is on the ground or in the air. The two inputs have different affects on transponder operation, and the status of the two are combined. SQUAT SWITCH 1 (NO) causes the transponder to indicate the in the air/ on the ground condition in replies to interrogations. SQUAT SWITCH 2 (NO) in addition to performing the function of SQUAT SWITCH 1 (NO), also inhibits replies to ATCRBS, ATCRBS/Mode S All–Call, and Mode S All–Call interrogations when the aircraft is “on the ground”. The air/ground polarity is set by the SQUAT SWITCH POLARITY strap. The matrix that follows, shows how the discrettes affect the transponder operation:</p> <table border="1"> <thead> <tr> <th align="center">Squat Sw Polarity Strap</th> <th align="center" colspan="2">Squat Switch Inputs</th> <th align="center" colspan="2">Transponder Operation</th> </tr> <tr> <th></th> <th align="center">1 (NO)</th> <th align="center">2 (NO)</th> <th align="center">Air/Ground Status</th> <th align="center">ATCRBS/All–Call Replies</th> </tr> </thead> <tbody> <tr><td align="center">Gnd</td><td align="center">Gnd</td><td align="center">Gnd</td><td align="center">On Ground</td><td align="center">Disabled</td></tr> <tr><td align="center">Gnd</td><td align="center">Gnd</td><td align="center">Open</td><td align="center">On Ground</td><td align="center">Enabled</td></tr> <tr><td align="center">Gnd</td><td align="center">Open</td><td align="center">Gnd</td><td align="center">On Ground</td><td align="center">Disabled</td></tr> <tr><td align="center">Gnd</td><td align="center">Open</td><td align="center">Open</td><td align="center">In Air</td><td align="center">Enabled</td></tr> <tr><td align="center">Open</td><td align="center">Gnd</td><td align="center">Gnd</td><td align="center">In Air</td><td align="center">Enabled</td></tr> <tr><td align="center">Open</td><td align="center">Gnd</td><td align="center">Open</td><td align="center">On Ground</td><td align="center">Disabled</td></tr> <tr><td align="center">Open</td><td align="center">Open</td><td align="center">Gnd</td><td align="center">On Ground</td><td align="center">Enabled</td></tr> <tr><td align="center">Open</td><td align="center">Open</td><td align="center">Open</td><td align="center">On Ground</td><td align="center">Disabled</td></tr> </tbody> </table>	Squat Sw Polarity Strap	Squat Switch Inputs		Transponder Operation			1 (NO)	2 (NO)	Air/Ground Status	ATCRBS/All–Call Replies	Gnd	Gnd	Gnd	On Ground	Disabled	Gnd	Gnd	Open	On Ground	Enabled	Gnd	Open	Gnd	On Ground	Disabled	Gnd	Open	Open	In Air	Enabled	Open	Gnd	Gnd	In Air	Enabled	Open	Gnd	Open	On Ground	Disabled	Open	Open	Gnd	On Ground	Enabled	Open	Open	Open	On Ground	Disabled
Squat Sw Polarity Strap	Squat Switch Inputs		Transponder Operation																																																
	1 (NO)	2 (NO)	Air/Ground Status	ATCRBS/All–Call Replies																																															
Gnd	Gnd	Gnd	On Ground	Disabled																																															
Gnd	Gnd	Open	On Ground	Enabled																																															
Gnd	Open	Gnd	On Ground	Disabled																																															
Gnd	Open	Open	In Air	Enabled																																															
Open	Gnd	Gnd	In Air	Enabled																																															
Open	Gnd	Open	On Ground	Disabled																																															
Open	Open	Gnd	On Ground	Enabled																																															
Open	Open	Open	On Ground	Disabled																																															
<b>J1–74</b>	<p><b>XPDR OFF (NO) INPUT:</b></p> <p>This discrete input is used to turn the transponder power supply OFF. It should not be connected in aircraft installations.</p>																																																		
<b>J1–75</b>	<p><b>SQUAT SWITCH 2 (NO) DISCRETE INPUT:</b></p> <p>See pin 73.</p>																																																		
<b>J1–80 thru 85 J1–94 thru 98</b>	<p><b>ENCODING ALTIMETER NO. 2 ELEVEN BIT INPUT:</b></p> <p>Transponder input from Encoding Altimeter No. 2. These eleven (11) lines from the altitude encoder comprise an 11–bit word representative of the aircraft altitude.</p>																																																		
<b>J1–90</b>	<p><b>XPDR STRAP +5 VOLT OUTPUT:</b></p> <p>Connect Strap Board connector pin W1P1–3 (red wire) to J1–90. This output pin provides the +5 volt input power required by the Strap Assembly.</p>																																																		
<b>J1–91</b>	<p><b>XPDR STRAP CLOCK (N) OUTPUT:</b></p> <p>Connect Strap Board connector pin W1P1–6 (blue wire) to J1–91. This output consists of 48 clock pulses that serially shift the system options data out of the Strap Assembly shift registers.</p>																																																		
<b>J1–92</b>	<p><b>XPDR STRAP LOAD (N) OUTPUT:</b></p> <p>Connect Strap Board connector pin W1P1–2 (orange wire) to J1–92. This output is used to load the system options status into the Strap Assembly shift registers during initial system power–up.</p>																																																		





**SYSTEM DESCRIPTION AND INSTALLATION MANUAL**  
TCAS 3000 Traffic Alert and Collision Avoidance System

**Table 4–9. RCZ–852 Diversity Mode S Transponder Interface Descriptions (cont)**

<b>Connector Pin Designation</b>	<b>Functional Description</b>
<b>J1–93</b>	<b>XPDR STRAP DATA (P) INPUT:</b> Connect Strap Board connector pin W1P1–7 (white wire) to J1–93. This input receives the serial data from the Strap Assembly that is used to program the desired system options and Mode S address.
<b>J1–99</b>	<b>XPDR ACTIVE (NO) OUTPUT:</b> This discrete output can be connected to an RF relay for systems that use a single antenna connected to two transponders for the purpose of switching the antenna to the active transponder. A Ground (200 mA maximum) output is provided when an Active transponder mode is selected. An Open (>100K ohms to ground) output is provided when Standby mode is selected.
<b>J1–100</b>	<b>XPDR VALID (NO) OUTPUT:</b> This discrete outputs the status of the transponder continuous monitor tests. A Ground (200 mA maximum) output is provided when the transponder is operational and an active transponder mode is selected. An Open (>100K ohms resistance to ground) output is provided when the transponder has failed or the Standby mode is selected. This pin should be connected to the Control Panel XPDR FAIL input.
<b>J1–102</b>	<b>ALT VALID (NO) OUTPUT:</b> This discrete outputs the status of the altitude source when the transponder is in an active mode and altitude reporting is enabled. A Ground (200 mA maximum) is output when the selected altitude source is valid and the transponder is in an altitude reporting mode. An Open (>100K ohms resistance to ground) output is provided when the selected altitude source is invalid or the transponder is in Standby or not in an altitude reporting mode. This pin should be connected to the Control Panel ALT FAIL input if applicable.
<b>J1–103</b>	<b>XPDR STRAP GROUND OUTPUT:</b> Connect Strap Board connector pin W1P1–4 (black wire) to J1–103. This output is the return line for the +5 volt output. See pin 90.
<b>J1–104</b>	<b>RESERVED FUNCTION:</b> Connect Strap Board connector pin W1P1–1 (green wire) to J1–104.
<b>J1–105</b>	<b>RESERVED FUNCTION:</b> Connect Strap Board connector pin W1P1–8 (yellow wire) to J1–105.
<b>J2</b>	<b>BOTTOM ANTENNA RF INPUT:</b> RF input signal from bottom antenna.
<b>J3</b>	<b>TOP ANTENNA RF INPUT:</b> RF input signal from top antenna.



**SYSTEM DESCRIPTION AND INSTALLATION MANUAL**  
 TCAS 3000 Traffic Alert and Collision Avoidance System

**ADJUSTMENT/TEST**

**1. General**

The procedures that follow are designed to check for proper operation and satisfactory installation of the TCAS 3000 Traffic Alert and Collision Avoidance System components.

Should any failures occur when you do the check out procedures, refer to FAULT ISOLATION as required.

**2. Equipment and Materials**

**Table 5-1. Equipment and Materials**

Name	Description	Source
Digital Multimeter	Fluke Model 29 Digital Multimeter	John Fluke Mfg Co Inc, Everett, WA
TCAS Ramp Tester	TCAS-201 Reply Generator Traffic Alert and Collision Avoidance System Test Set	IFR Systems, Inc. Wichita, KS
<b>NOTE:</b> Equivalent alternatives are permitted for equipment in this list.		

**3. Initial Harness Checkout (New Installations Only)**

**A. TCAS Computer Unit Harness Checkout**

Check the TCAS computer unit's mounting tray connector pins referenced in Table 5-2, to make sure they are not connected or shorted to ground. A ground on these pins can cause damage or degrade system performance.

**Table 5-2. Computer Unit Harness Checkout**

Connector Pin No.	Pin Function
P1C-1 (LBP)	115 V AC (H) TCAS Power
P1C-5 (LBP)	115 V AC (H) External Fan
P1C-10 (LBP)	28 V AC TCAS Power

**B. TCAS Controller and Display Unit Harness Checkout**

Refer to the applicable controller and display unit interconnect diagrams to do continuity measurements and to ensure confidence in wiring for these units.



**SYSTEM DESCRIPTION AND INSTALLATION MANUAL**  
TCAS 3000 Traffic Alert and Collision Avoidance System

**C. LRU Preinstallation Power Checkout**

Before you do any operational tests, a power-on check is recommended to reduce the possibility of damage to newly installed system components due to miswired power leads.

- (1) Make sure all TCAS system components are removed from their mounting trays or that their aircraft mating connector(s) are disconnected.
- (2) Connect external power to aircraft.
- (3) Close all TCAS system 115 V, 400 Hz circuit breakers, if applicable, and check for 115 V ac at the appropriate LRU mating connector pins. Refer to the applicable interconnect diagrams for LRU pin numbers.
- (4) Close all TCAS system 28 V dc circuit breakers, if applicable, and check for 28 V dc at the appropriate LRU mating connector pins. Refer to the applicable interconnect diagrams for LRU pin numbers.
- (5) If power is misapplied on any connector pin, open the circuit breaker and rework miswired harness.
- (6) Remove aircraft power.

**D. Initial System Installation Operational Test**

The initial checkout of a newly installed system should start with a system self-test and then be followed by a ramp test. The system self-test procedures are referenced in paragraph 4.A. The ramp tests should include a Scenario Test and a Power and Frequency Test. Refer to the applicable TCAS Ramp Tester Operation Manual for procedures to do these tests.

If a ACSS VSI/TRA is used as the display instrument, it contains a feature that displays some typical installation errors. See Figure 5-1. If an error is detected during initial installation checkout, the VSI/TRA displays the error as follows:

- (1) Removes all symbology from the display
- (2) Displays a red **X** that covers the entire screen
- (3) Displays a two digit error code as follows:
  - 00 = Invalid discrete setting at power-up
  - 01 = Invalid light curve setting specified at power-up
  - 03 = Bad checksum detected at power-up
  - 04 = Illegal op-code test failed
  - 05 = Unsupported test failed.
- (4) Strobes the watchdog timer to keep the red **X** and status displayed.

**NOTE:** If the VSI/TRA displays error code 10, 11, 12, 29, 30, 31, or 40 an internal VSI/TRA failure has been detected.



**SYSTEM DESCRIPTION AND INSTALLATION MANUAL**  
TCAS 3000 Traffic Alert and Collision Avoidance System

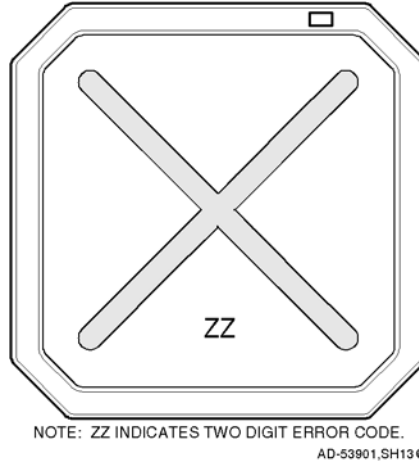

**Figure 5-1. VSI/TRA Fault Warning Display**

## 4. System Self-Tests

### A. Cockpit Display Test Modes

The TCAS 3000 System provides two types of test modes; a short functional test mode and an extended maintenance test. Both test modes can be activated by the TEST button or switch on the ATC/TCAS Control Panel. The short test mode can also be activated by a central maintenance computer (CMC) or a central fault display interface unit (CFDIU). The extended test mode can only be initiated at the end of the short test. The short test mode is inhibited in the air if the Self-Test Inhibit programming pin (RBP-8E) is grounded.

#### (1) Short Test Mode

The short test mode provides a flight deck initiated functional test of the TCAS RA and TA displays and associated TCAS interfaces. It also provides an aural annunciation of the TCAS system status.

The short test mode is available in all TCAS operational modes (Standby, TA Only, or TA/RA) when on the ground. If a TA or RA occurs while airborne, the test is terminated and normal operating status is resumed. The test mode is also terminated if any of the Advisory Inhibit discrete inputs (grounds) are received on pins RBP-5A, RBP-5B, RBP-5C, or RBP-5D.

Push and hold the TEST button/switch on the ATC/TCAS controller for a few seconds to start the test. When the test mode becomes active, the words "tcas test" are transmitted once aurally. In addition to the TCAS test pattern, RA indications and a red TCAS TEST annunciation are displayed on the applicable display(s). Refer to Figure 1-18 for a typical test pattern display on the VSI/TRA.



## SYSTEM DESCRIPTION AND INSTALLATION MANUAL

TCAS 3000 Traffic Alert and Collision Avoidance System

At the completion of the test (8–seconds), the words “tcas test pass” should be transmitted once aurally. In addition, the test pattern is removed from the display(s) and a TCAS PASS annunciation is displayed. If the test fails, the words “tcas test fail” are transmitted once aurally and a TCAS FAIL annunciation is displayed on the applicable display(s).

If the TCAS short test fails, do the TCAS Computer Unit Self–Test procedures referenced in paragraph 4.B. to determine which LRU or subsystem is not functioning properly. To troubleshoot the system, refer to the procedures in the FAULT ISOLATION section.

### (2) Extended Test Mode

The extended test mode provides a flight deck initiated test that displays various pages of text information that is selected by the ATC Mode S control panel 4096 code switches. This test mode is accessible only when on the ground and cannot be initiated while airborne.

The extended test mode is used for maintenance purposes only. It displays various pages of text information containing the TCAS software part number, fault messages, status of program pins, analog and digital inputs, and other aircraft parameters.

To start the test, push and hold the TEST button/switch on the ATC/TCAS controller for a minimum of 9 seconds. In addition the conditions that follow must occur:

- TCAS is in Standby
- The selected transponder is in Standby
- Aircraft is on the ground (The AIR/GND discrete [RMP–5K] is grounded)
- Landing gear is extended (Landing Gear discrete [RMP–13F] is grounded).

Once the extended test mode is established, the 4096 code switches on the ATC/TCAS controller are used to select the desired maintenance page for display. Table 5–3 lists the extended mode page names and numbers and the corresponding 4096 Ident Code number.



**SYSTEM DESCRIPTION AND INSTALLATION MANUAL**  
TCAS 3000 Traffic Alert and Collision Avoidance System

**Table 5-3. Extended Test Menu Selections**

4096 Ident Code Number	Page	Page Name
0000	0	System Status
0001	1	Display Status
0002	2	Rad/Alt Status
0003	3	Xpdr Status
0004	4	Program Pins 1/3
0005	5	Program Pins 2/3
0006	6	Program Pins 3/3
0007	7	Help Reference
0011	11	Antenna Port Status
0012	12	Option Pins Status
0013	13	Part Numbers
All Other Codes	Blank	TCAS Test Menu

To view the TCAS test menu and system status pages along with the troubleshooting messages, refer to the FAULT ISOLATION section.

To exit the extended test mode, set the ATC/TCAS mode selector switch to Mode S ON.

**B. TCAS Computer Unit Self-Test**

- (1) With all power off, reinstall the TCAS computer unit in its mounting tray. Make sure the TCAS control panel and display(s) are also installed.
- (2) Apply aircraft power and close all applicable TCAS system circuit breakers.
- (3) Set the ATC/TCAS controller mode switch to Mode S ON.
- (4) Push the PUSH TO TEST button on the TCAS computer unit front panel. The test sequence that follows should occur:
  - All TCAS computer unit front panel annunciators come on for a 3-second lamp test
  - If the TCAS is operational, the TCAS PASS green annunciator comes on for a 10-second display period and then goes off.
  - If the TCAS is not operational, one or more of the red fault annunciators comes on for a 10-second display period.
- (5) If a fault is detected, refer to the Fault Isolation section for troubleshooting information.



**SYSTEM DESCRIPTION AND INSTALLATION MANUAL**  
TCAS 3000 Traffic Alert and Collision Avoidance System

## **5. Return to Service Test**

Any time a TCAS LRU is removed and replaced following repair or maintenance, a return to service test is required. The System Self-Test procedures referenced in paragraph 4.A. are sufficient to check all system parameters.

## **6. Operational Software Loading Using an ARINC Portable Data Loader**

When updating the TCAS 3000 Computer Unit with an ARINC portable data loader PDL, verify the current TCAS 3000 Computer Unit software part number prior to continuing for cockpit system only.

### **A. Current Software Verification**

**NOTE:** Software verification using cockpit systems ONLY.

Verify the current software part number according to the extended maintenance capabilities on status page code 0000 in the FAULT ISOLATION section of this manual or the individual aircraft maintenance manual (refer to the onboard maintenance system program).

### **B. Operational Software Loading (While Installed on Aircraft)**

- (1) Verify that the system inputs for AIR/GROUND (RMP-5K) and GEAR UP/DOWN (RMP-13F) are grounded.
- (2) Obtain an ARINC PDL and the appropriate interface cable for connecting the data loader to the J1 (front) connector of the TCAS 3000 Computer Unit.

The following PDLs have been tested and found to be satisfactory for performing this task:

- DEMO Systems – Part No. 30100 (Revision A and later versions)
- Teledyne – Part No. 2230915-01-D
- SFIM – Part No. YV68A110.

Other part numbers from these suppliers and ARINC 615 data loaders from other manufacturers may perform the task successfully. However, ACSS can not verify their usability.

- (3) Shut off the PDL and remove power from the TCAS 3000 Computer Unit. Connect the cable between the PDL and the J1 front connector on the TCAS 3000 Computer Unit.
- (4) Apply power to the TCAS 3000 Computer Unit.
- (5) Turn on the PDL.
- (6) Obtain the operational software. Insert disk No. 1 of the operational software into the PDL for program uploading (or follow the applicable instructions for the PDL).



## SYSTEM DESCRIPTION AND INSTALLATION MANUAL

### TCAS 3000 Traffic Alert and Collision Avoidance System

- (7) After the PDL indicates that the disk upload was successful, repeat step (6) for multiple disks, if necessary.
- (8) Wait at least 20 seconds after the last disk has finished uploading. Then turn off the PDL, remove power from the TCAS 3000 Computer Unit, and disconnect the interface cable.
- (9) Apply power to the TCAS 3000 Computer Unit and ensure the TCAS system is fully operational. Push the PUSH TO TEST button located on the front panel. The green LED indicator on the front of the panel lights at the end of the test cycle (approximately 8 seconds) to show the TCAS system is functional.

#### C. Compact Flash Card – (While Installed on Aircraft)

- (1) Procedure For Uploading OPS SW Through Compact Flash Card
  - (a) Obtain the operational software.
  - (b) Verify that the aircraft is “on the ground” prior to performing an upload. The OPS SW cannot be uploaded while the aircraft is airborne.
  - (c) Apply power to the TCAS 3000 computer unit.
  - (d) Open the CF card protective door located on the left side. (See Figure 5–2)
  - (e) Insert the CF card with the label facing the TCAS 3000 Computer unit front panel LEDs. (See Figure 5–2)
  - (f) All LEDs will illuminate, which indicates TCAS 3000 Computer unit restart.
  - (g) All LEDs will extinguish and the XFER IN PROCESS LED will start to blink. The blinking XFER IN PROCESS LED indicates that the unit is reading the CF card.
  - (h) The XFER IN PROCESS LED will indicate continuous green. The continuous XFER IN PROCESS LED indicates that the unit is loading the contents of the CF card. The loading process takes over one minute.
  - (i) Step NO TAGNO TAG(f), step NO TAGNO TAG(g), and step NO TAGNO TAG(h) may repeat if the DL or FPGA files on the CF card are different than those previously loaded on the TCAS 3000 Computer unit. If the files are not changed, step NO TAGNO TAG(f), step NO TAGNO TAG(g), and step NO TAGNO TAG(h) only occur once.
  - (j) When the upload is successful, the CF Load Status LED changes to a continuous green indication.
  - (k) An unsuccessful upload is indicated by amber LEDs displayed during the upload process. The LED correlations are listed in Table 5–4.
  - (l) Once the upload is successful, remove the CF card from the TCAS 3000 Computer unit front panel. (See Figure 5–3)







**SYSTEM DESCRIPTION AND INSTALLATION MANUAL**  
 TCAS 3000 Traffic Alert and Collision Avoidance System



Location of compact flash card ejector

**Figure 5-3. Compact Flash Card Ejector Location**

**Table 5-4. Compact Flash Upload / LED Correlation**

<b>Triggering Event</b>	<b>CF Status LED</b>	<b>XFER IN PROCESS LED</b>	<b>Fault Type Logged</b>	<b>Ending Event</b>
CF Card Inserted		Blink	CF UPLOAD REQUEST	CRC 1 completed
Corrupt CF header	Red		CF FILE ERROR	CF Card removed
Upload Card Inserted while Airborne	Red		CF FILE ERROR	CF Card removed
Incorrect Configuration Error	Red		CF FILE ERROR	CF Card removed
Major/Minor Incompatibility	Red		CF FILE ERROR	CF Card removed
File Header CRC error	Red		CF FILE ERROR	CF Card removed



**SYSTEM DESCRIPTION AND INSTALLATION MANUAL**  
TCAS 3000 Traffic Alert and Collision Avoidance System

**Table 5-4. Compact Flash Upload / LED Correlation (cont)**

<b>Triggering Event</b>	<b>CF Status LED</b>	<b>XFER IN PROCESS LED</b>	<b>Fault Type Logged</b>	<b>Ending Event</b>
File does not exist error	Red		CF FILE ERROR	CF Card removed
Multiple file error	Red		CF FILE ERROR	CF Card removed
File Image CRC error (CRC 1)	Red		CF FILE ERROR	CF Card removed
CRC 1 completed		Green	CF LOAD	CF Card error is detected or upload completed or restart
Aborted Upload	Red		CF WRITE ERROR	10 seconds after card removal
Airborne Upload	Red		CF FILE ERROR	CF Card removed
Ground-to-air transition during upload		Green (per normal uploading sequence)	CF FILE ERROR	CF Card error is detected or upload completed or restart
Flash Copy CRC fails to match CF File CRC (CRC 2)	Red		CF WRITE ERROR	Card removal
Flash Copy 2 fails to match CRC at Copy 1 location	Red		FLASH EPROM ERROR	Card removal
APM Calculated CRC doesn't match CF File CRC.	Red		APM WRITE ERROR - CF Upload	Card removal
APM Calculated CRC doesn't match APM embedded CRC.	Red		APM DATA FAULT - CF Upload	Card removal
APM write to Flash unsuccessful	Red		APM COPY WRITE - CF Upload	Card removal
APM Calculated CRC doesn't match APM embedded CRC	Red		APM Copy CRC - CF Upload	Card removal
All files loaded successful	Green		CF UPLOAD SET COMPLETE	Card removal



## SYSTEM DESCRIPTION AND INSTALLATION MANUAL

TCAS 3000 Traffic Alert and Collision Avoidance System

### D. Updated Software Verification

#### (1) Software Verification Using Cockpit Systems ONLY

Verify the updated software part number according to the TCAS 3000 extended maintenance capabilities on status page code 0000 in the FAULT ISOLATION section of this manual or the individual aircraft maintenance manual (refer to the onboard maintenance system program).

#### (2) Software Verification Using a Stand-Alone PC ONLY

Verify the updated software part number using a stand-alone PC according to the following procedure.

- (a) Obtain PC software Part No. PS4088035-101.
- (b) Obtain or build an RS-232 cable. (Refer to Figure 5-4.)
- (c) Shut off the PC.
- (d) Remove power from the TCAS 3000 Computer Unit.
- (e) Connect the RS-232 cable from the PC (9-pin connector) to the J1 front connector on the TCAS 3000 Computer Unit.
- (f) Apply power to the TCAS 3000 Computer Unit.
- (g) Power on the PC to Microsoft Windows operation.
- (h) On the PC, go to START => PROGRAMS => ACSS TOOLS and double click "TCAS Part Number".
- (i) Verify the updated TCAS software part number.
- (j) Shut down the PC and remove power.
- (k) Remove power from the TCAS 3000 Computer Unit.
- (l) Disconnect the RS-232 cable from the J1 front connector on the TCAS 3000 Computer Unit.



**SYSTEM DESCRIPTION AND INSTALLATION MANUAL**  
TCAS 3000 Traffic Alert and Collision Avoidance System

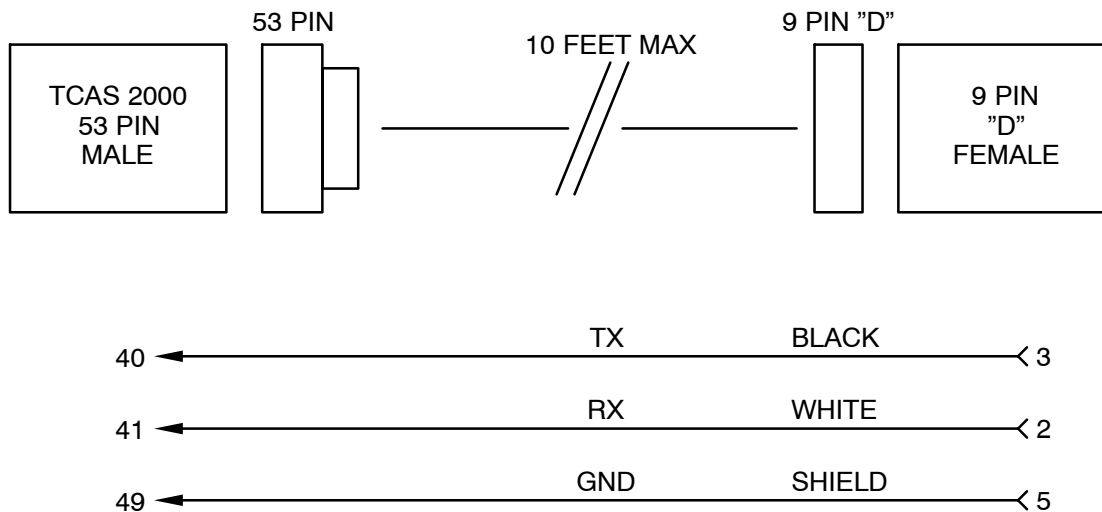

**NOTES:**

1. Mating J1 front connector on the TCAS 2000 RT-950/-951 Computer Unit:

HI 4004295-160 or  
ITT KJ6F18A53P or  
MS27473E18A53P or  
JT06RE-18-53P

2. Mating connector to the PC:

Standard 9-pin, D-submini connector with female contacts.

3. A single, twisted-pair, shielding wire using the shield as the common ground is a popular wiring choice.

ID-39471

**Figure 5-4. RS-232 PC to TCAS Interface Cable**



## SYSTEM DESCRIPTION AND INSTALLATION MANUAL

TCAS 3000 Traffic Alert and Collision Avoidance System

### (3) Software Verification Using a Software Verification Fixture ONLY

**NOTE:** Software versions prior to Change 7 can not be displayed on the Software Verification Fixture.

- (a) Obtain Software Verification Fixture (Part No. T326948-901) with associated adapter cable (Part No. 200F-00084).
- (b) Remove power to the TCAS 3000 Computer Unit.
- (c) Connect the adapter cable (Part No. 200F-00084) to the TCAS 3000 Computer Unit and the software verification fixture.
- (d) Apply power to the TCAS 3000 Computer Unit.
- (e) Enable the software verification fixture and verify the appropriate software part number is displayed in the 15-digit display.
- (f) Perform a TCAS system self-test and verify that TCAS TEST PASS is annunciated.

**NOTE:** The TCAS TEST FAIL message may be annunciated if an LRU that supplies input to the TCAS 3000 Computer Unit is not powered on.

- (g) If the software part number is not displayed, repeat step (a) thru step (f).

### (4) Software Verification Using a Remote Connected VSI/TRA ONLY

On some aircraft configurations, software verification may be performed using a remote connected VSI/TRA (Part No. 4067241-861, -862, or -863) display attached through adapter cable (Part No. 200F-00083) to the J1 front connector of the TCAS 3000 Computer Unit during the extended test mode.

Verify the particular aircraft configuration can support a cockpit initiated self-test and be recognized at the 8-second time period after activation.

**NOTE:** CMC/CFDS activated self-test will not be recognized at the 8-second time period, only an approved TCAS control panel.



**SYSTEM DESCRIPTION AND INSTALLATION MANUAL**  
TCAS 3000 Traffic Alert and Collision Avoidance System

Blank Page





**SYSTEM DESCRIPTION AND INSTALLATION MANUAL**  
TCAS 3000 Traffic Alert and Collision Avoidance System

## **FAULT ISOLATION**

### **1. General**

The TCAS 3000 Traffic Alert and Collision Avoidance System has three optional procedures for fault detection and isolation to the LRU level. The first option uses the aircraft's CMC or central fault display system (CFDS) if the aircraft is equipped with an onboard maintenance system. The second option uses a digital interface between the TCAS Computer Unit and the display system (EFIS, multifunction display or VSI/TRA flat panel display). The third option uses the annunciators located on the front panel of the computer unit. The annunciators are activated by a self-test function within the TCAS Computer Unit. Select the procedural option for fault isolation from paragraph 3., Procedure, which is applicable to the type of aircraft and the equipment installed.

### **2. Equipment and Materials**

**NOTE:** Equivalent alternatives are permitted for equipment in this list.

Digital Multimeter – Fluke Model 29, John Fluke Mfg Co. Inc., Everett, WA

### **3. Procedure**

#### **A. CMC or CFDS**

Fault information can be displayed from an onboard maintenance system when the aircraft is so equipped. Fault data is accessible only when the aircraft is on the ground. Faults that occur at any time, on the ground or while airborne, are stored in fault memory and reported to the CMC or CFDS. All displayed information is in the English language with abbreviated terms used only as necessary. Refer to the appropriate CMC or CFDS support manual for fault retrieval procedures.

#### **B. TCAS Display System**

The TCAS display system can be used to display system status and fail messages in the cockpit, making it more convenient to use than the computer unit front panel annunciators for a quick checkout of the TCAS system. In contrast with the computer unit self-test, which records and stores faults from previous flights, the display system test shows only current status and failure data.





**SYSTEM DESCRIPTION AND INSTALLATION MANUAL**  
TCAS 3000 Traffic Alert and Collision Avoidance System

To access the cockpit display test modes, do the procedures that follow:

**NOTES:**

1. Fault detection with diagnostics can only be done on the ground. The pilot has the option to do a pass/fail test while airborne if this feature is not inhibited.
  2. This procedure is valid when used with either a single or dual control panel.
- (1) Make sure the aircraft configuration indicates Aircraft On Ground and Gear Extended.
  - (2) Set the Mode Select switch on the ATC/TCAS control panel to STBY.
  - (3) Push and hold the TCAS TEST button for a minimum of 9 seconds.
  - (4) Set the transponder 4096 Ident Code Number to any code except 0000 thru 0007, 0011, 0012, 0013.  
  
**NOTE:** Do not use codes 7500, 7600, or 7700; these code are reserved for emergency operation.
  - (5) Make sure the TCAS TEST MENU is being displayed on the TCAS display. It should match the screen shown in Figure 6-1.
  - (6) Set the transponder 4096 Ident Code Number to 0000.
  - (7) If the system passes, a maintenance page similar to that shown on Figure 6-2 is displayed. A failure results in a referral to one or more specific ident codes. Set the indicated code on the ATC/TCAS Control Panel and follow the instructions given.
  - (8) If the system passes, set the mode switch on the ATC/TCAS Control Panel to MODE S ON. This allows you to exit the expanded test mode. If a failure is indicated, set the transponder 4096 Ident Code to the codes indicated by the automatic referral system. The remaining screens shown on Figure 2-4 thru Figure 2-14 are examples of the other maintenance pages.
  - (9) Set system power to OFF and correct faults by replacing indicated LRUs or by repairing faulty wiring harness.
  - (10) Test system as required after repair.



**SYSTEM DESCRIPTION AND INSTALLATION MANUAL**  
TCAS 3000 Traffic Alert and Collision Avoidance System

**C. TCAS Aural and VSI/TRA Annunciations**

TCAS aural and VSI/TRA annunciations are given in Table 6-1.

**Table 6-1. TCAS Aural and VSI/TRA Annunciations**

Condition	Aural	VSI/TRA Annunciation				Notes
		Upper Left	Upper Right	Center	Color	
TRAFFIC Display Control ON Mode	Normal					Range ring and own aircraft in view at all times, along with qualifying traffic.
TRAFFIC Display Control AUTO Mode	Normal					Range ring and own aircraft come up with traffic when a TA or RA exists.
Transponder Only Mode	None			TCAS OFF	White	TCAS is not operational.
STANDBY Mode	None			TCAS OFF	White	TCAS is not operational, transponder is in standby.
Vertical Speed Input Failure to Single VSI (Dual VSI Aircraft)	Normal	RA FAIL on failed side	VSI FAIL on failed side		Yellow	Vertical speed needle removed from display with failed data. No RAs posted on failed side. TCAS is operational on remaining side.
VSI Input Failure to Both (Dual VSI Aircraft) or Single VSI (Single VSI Aircraft)	None		VSI FAIL on both sides	TCAS FAIL on both sides	Yellow	Vertical speed needle removed from both VSIs (dual VSI aircraft) or only VSI (single VSI aircraft). No RA information posted. TCAS is not operational.
TA Only Mode	Traffic – Traffic only	TA ONLY			White or Yellow	Traffic alerts are the only information displayed. No RAs. (The color changes from white to yellow when a TA actually occurs.)
Transponder or Altitude Source Fail	None			TCAS FAIL	Yellow	TCAS is not operational.
Altitude Reporting OFF				TCAS OFF	White	TCAS is not operational.
ATCRBS Transponder Selected	None			TCAS OFF	White	TCAS is not operational.



**SYSTEM DESCRIPTION AND INSTALLATION MANUAL**  
TCAS 3000 Traffic Alert and Collision Avoidance System

**Table 6-1. TCAS Aural and VSI/TRA Annunciations (cont)**

Condition	Aural	VSI/TRA Annunciation				Notes
		Upper Left	Upper Right	Center	Color	
RA Only (TA Display Control to OFF)				RA ONLY	White	VSI/TRA displays resolution advisories only.
RA Fail		RA FAIL	VSI FAIL		Yellow	No resolution advisories displayed.
Traffic Display Failure				TD FAIL	Yellow	No traffic advisories displayed.
Single VSI/TRA Failure (Dual VSI Aircraft)	Normal			X across failed display	Red	On failed side, all symbology removed and replaced with a large red <b>X</b> and hex-coded failure number. TCAS operational on good side.
Dual VSI/TRA Failure (or Single on Single VSI Aircraft)	None			X across both displays	Red	All symbology removed from both displays and replaced with a large red <b>X</b> and failure code. TCAS is not operational.
Cockpit Lamp Test	Normal			Display full white		During cockpit lamp test, display goes full white and displays no symbology.
TCAS SELF TEST (Note 1.)						
TCAS Test Mode (First Second)	<i>TCAS TEST</i>	TCAS TEST			White	TCAS system self test.
TCAS Test Mode (2 to 8 Seconds)		TCAS TEST			White	TCAS test pattern shown.
TCAS Test Mode (at 8 Seconds)	<i>TCAS TEST PASS/ FAIL</i>	TCAS TEST				TCAS test pattern removed and TCAS returns to normal operation unless the test switch is held, the aircraft is on the ground, and TCAS is in STBY.



**SYSTEM DESCRIPTION AND INSTALLATION MANUAL**  
 TCAS 3000 Traffic Alert and Collision Avoidance System

**Table 6-1. TCAS Aural and VSI/TRA Annunciations (cont)**

Condition	Aural	VSI/TRA Annunciation				Notes
		Upper Left	Upper Right	Center	Color	
TCAS EXTENDED SELF TEST (MAINTENANCE ONLY) (Note 2.)						
TCAS Extended Test Mode (Test Switch Held at 7 Seconds for 2 Seconds and Aircraft on the Ground Only)				System information pages	White	Current status of the TCAS system, transponder, antennas, radio altimeters, barometric altitude, etc is presented in a series of pages called by selection of 4096 code.
<b>NOTES:</b>						
<ol style="list-style-type: none"> <li>1. Self Test should only be run in STANDBY mode in flight or on the ground.</li> <li>2. Extended Self Test provides maintenance information on seven screens selected using 4096 code. This mode is available only on the ground and in STANDBY. Extended Self Test ends automatically with a TCAS/Transponder mode change or if the aircraft becomes airborne.</li> </ol>						



**SYSTEM DESCRIPTION AND INSTALLATION MANUAL**  
TCAS 3000 Traffic Alert and Collision Avoidance System

**D. TCAS Test Menu and System Status Pages**

The extended test mode provides maintenance information on the TCAS display. Pages are selected by 4096 codes on the transponder control panel. The extended test mode is accessible only on the ground, with the transponder in standby.

To start the extended test mode, select STBY and push the transponder control panel TCAS TEST switch for 8 seconds. To exit the extended test mode, move the transponder mode control out of STBY.

(1) TCAS Test Menu

The TCAS Menu Page, Figure 6-1, can be displayed whenever a TCAS suppression bus failure is not indicated and the 4096 Ident Code is any code other than 0000 thru 0007, 0011, 0012, or 0013. If a TCAS suppression bus failure is indicated, all 4096 Ident Codes other than 0000 thru 0007, 0010 thru 0013 and 0510 can be used to select the TCAS Test Menu.

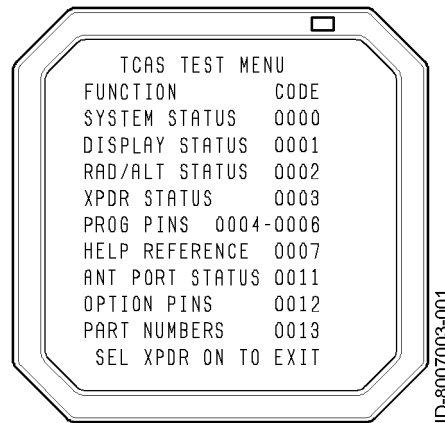

**Figure 6-1. TCAS Test Menu Page**



**SYSTEM DESCRIPTION AND INSTALLATION MANUAL**  
 TCAS 3000 Traffic Alert and Collision Avoidance System

(2) System Status Page

Selection of code 0000 displays the System Status page, Figure 6–2. This page displays the PASS or FAIL status of the TCAS system and the current version of the operating software loaded into the TCAS computer.

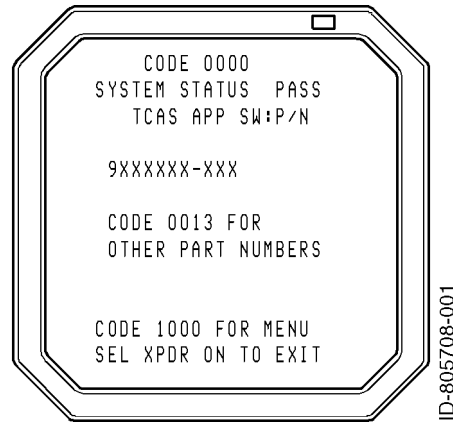

**Figure 6–2. Typical System Status Page**

In the event of a detected system failure, one or more of the messages in Table 6–2 are displayed. Lines 6 thru 10 of the display screen are used to display the five highest priority faults within the TCAS system. A maximum of five messages can be displayed.

**Table 6–2. System Status Page Fault Messages**

Priority	Message	Description
1	SUPP FAULT GOTO 0010	Suppression bus failure. Select page 0010 for more information.
2	TCAS CU FAIL	TCAS computer unit has failed BITE test.
3	ANT FAIL TOP	Antenna failure. Message field will display TOP, BOT or BOTH to indicate which antenna failed.
4	DISP FAIL GOTO 0001	TCAS has lost valid signal from display. Select page 0001 for more information.
5	RALT INACT GOTO 0002	TCAS has lost valid signal from radio altimeter. Select page 0002 for more information.
6	XPDR FAIL GOTO 0003	TCAS has lost valid signal from Mode S transponder. Select page 0003 for more information.
7	ANT FAIL GOTO 0011	One of the antenna ports connected to the TCAS CU has failed. Select page 0011 for more information.
8	OPT FAIL GOTO 0012	Parity for the option selections has failed. Select page 0012 for more information.



**SYSTEM DESCRIPTION AND INSTALLATION MANUAL**  
TCAS 3000 Traffic Alert and Collision Avoidance System

(3) Display Status Page

Selection of code 0001 displays the Display Status page, Figure 6-3. This page displays the current status of the Resolution Advisory and Traffic Advisory displays.

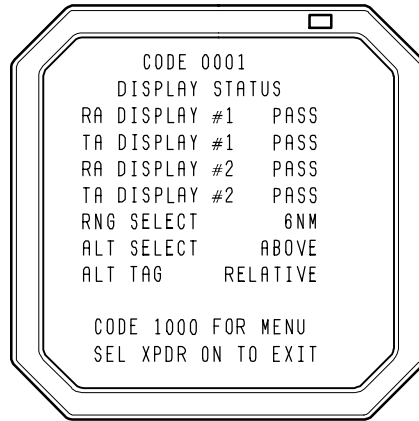

AD-53901.SH2@

**Figure 6-3. Typical Display Status Page**

The message contents for the Display Status page are determined as follows:

RA DISPLAY #1	PASS	Indicates valid signal (ground/low) is present at TCAS CU pin RMP-14C. Fail is displayed if this signal is an open/high.
TA DISPLAY #1	PASS	Indicates valid signal (ground/low) is present at TCAS CU pin RMP-7E. FAIL is displayed if this signal is an open/high.
RA DISPLAY #2	PASS	Indicates valid signal (ground/low) is present at TCAS CU pin RMP-13E. FAIL is displayed if this signal is an open/high.
TA DISPLAY #2	PASS	Indicates valid signal (ground/low) is present at TCAS CU pin RMP-7J. FAIL is displayed if this signal is an open/high.
RNG SELECT	6NM	Indicates current range selection for the traffic display. For installations using control panels without range select switches, range defaults to 6NM.
ALT SELECT	NORM	Indicates current selection of vertical display limits for traffic display - NORM, BELOW, or ABOVE. For installations that use control panels without ABV-NORM-BLW switch, limits default to NORM.
ALT TAG	RELATIVE	Indicates current selection on control panel for type of traffic symbol altitude indication, RELATIVE or FLT LVL. Default is RELATIVE if no switch is available on control panel.



**SYSTEM DESCRIPTION AND INSTALLATION MANUAL**  
TCAS 3000 Traffic Alert and Collision Avoidance System

(4) RAD/ALT Status Page

Selection of code 0002 displays the RAD/ALT Status page, Figure 6-4. This page displays the status of the selected radio altimeter interface to the TCAS.

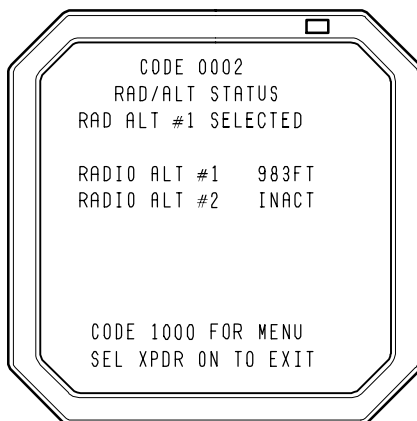

AD-53901.SH3@

**Figure 6-4. Typical RAD/ALT Status Page**

The first information line (line 3) of the RAD/ALT STATUS page indicates which of the two radio altimeter ports is being used by the TCAS computer. The TCAS computer attempts to use radio altimeter No. 1 first. If it determines this input is invalid, it automatically switches to radio altimeter No. 2.

The current status of the two radio altimeter ports is displayed on lines 5 and 6. If a signal is valid, the radio altitude value is displayed in either “FT” for English type altimeters, or “M” for Metric type altimeters.

If one of the radio altitude signals is determined to be invalid, the altitude value is replaced by INACT. Radio altitude INACT indicates the radio altimeter has failed, is not powered, or is not connected.

The radio altimeter input is determined to be invalid if, for an analog radio altimeter input, 28 V dc valid is not present at TCAS CU pin RMP-2K for Radio Alt #1 or pin RMP-3C for Radio Alt #2, or for a digital radio altimeter input, the sign status matrix (SSM) of the radio altimeter output indicates not valid or no data is present on the digital bus.

If the radio altimeter output is greater than 2200 feet (source is valid, but data is invalid), the radio altitude value is replaced by OVR RNG.

When both radio altitude sources are invalid, line 3 is blank.





**SYSTEM DESCRIPTION AND INSTALLATION MANUAL**  
TCAS 3000 Traffic Alert and Collision Avoidance System

(5) Transponder (XPDR) Status Page

Selection of code 0003 displays the XPDR Status page, Figure 6-5. This page displays data for the transponder selected at the time the extended test mode was entered.

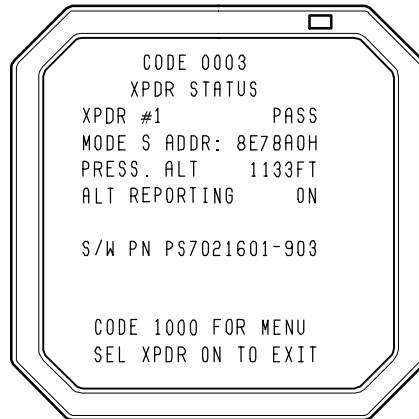

AD-53901,SH4@

**Figure 6-5. Typical Transponder (XPDR) Status Page**

The message contents for the XPDR Status page are determined as follows:

XPDR #1	PASS	Indicates PASS or FAIL status of the selected transponder (XPDR #1 or XPDR #2) as indicated by the digital transmission from that transponder. FAIL is displayed if no data is received on the bus.
MODE S ADDR:	8E78A0H	Indicates the Mode S address (in hexadecimal format) of the selected transponder as determined by program pins at the rear connector of the transponder. (See Note 1.)
PRESS. ALT	1133FT	Indicates the last pressure altitude being reported by the selected Mode S transponder before the TCAS system was placed into STBY. This value is not updated while in extended test mode.
ALT REPORTING	ON	Indicates current position of altitude reporting switch on Mode S/TCAS control panel – ON or OFF. S/W PN PS7021601-903 (See Note 2.)
<b>NOTES:</b>		
1. If the transponder detects either all 1's or all 0's, the following message will appear – ILLEGAL ADDRESS –. In addition, a fail message will appear on the front of the transponder and on Extended Test. The message reads CHECK DISCRETE ADDR WIRING ON XPDR PINS MP1A THROUGH MP3D.		
2. The S/W PN information, line 8 of the display screen, displays general text supplied by the ACSS ATDL transponder via label 356 (block transfer), which is equipped to supply the text to the display. If a transponder is installed that does not have this feature, line 8 is blank.		



**SYSTEM DESCRIPTION AND INSTALLATION MANUAL**  
TCAS 3000 Traffic Alert and Collision Avoidance System

(6) Programming Pins Status Pages

The following three displays indicate the status of various option programming pins located in the rear connector of the TCAS computer. The 1s and 0s following a programming option indicate the GROUND or OPEN status for those programming pins. Each 1 and 0 is associated with a program pin. A one (1) indicates the pin is grounded by connecting to a program common pin on the TCAS connector or to an aircraft ground. A zero (0) indicates the pin is left open.

Selection of code 0004 displays the first of three pages that define program pin status. See Figure 6-6.

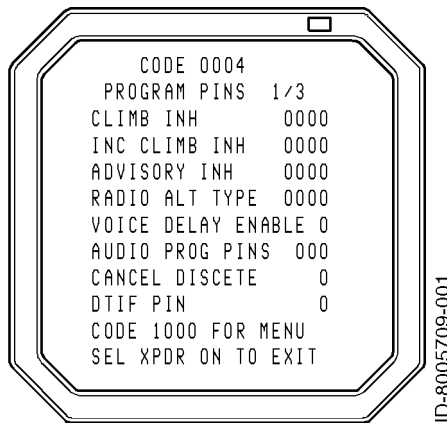

**Figure 6-6. Typical Program Pins 1/3 Page**



**SYSTEM DESCRIPTION AND INSTALLATION MANUAL**  
TCAS 3000 Traffic Alert and Collision Avoidance System

Programming pins on the TCAS computer associated with each of the functions defined on the page 1 display are listed below. Where more than one program pin is indicated, the listed connector pins correspond to the display digits read from left to right. A one (1) indicates the associated pin is grounded. A zero (0) indicates open.

CLIMB INH	0000	Climb Inhibit inputs: RMP-1J, RMP-13G, RBP-5J, RBP-5K.
INC CLIMB INH	0000	Increase Climb Inhibit inputs: RBP-5E, RBP-5F, RBP-5G, RBP-5H
ADVISORY INH	0000	Advisory Inhibit inputs: RBP-5A, RBP-5B, RBP-5C, RBP-5D
RADIO ALT TYPE <sup>1</sup>	0000	Analog Radio Altimeter Type: RMP-12B ARINC 552/552A (0), Collins BCA (1)
VOICE DELAY ENABLE	0	Voice Delay option: RBP-7D Enabled = (1), Disabled = (0)
AUDIO PROG PINS	000	Audio output level selection inputs: RBP-7A, RBP-7B, RBP-7C
CANCEL DISCRETE <sup>2</sup>	0	Advisory Cancel Discrete option: RMP-3D (0) allows advisories to be cancelled. A (1) does not allow advisories to be cancelled.
DTIF PIN	0	TBD



**SYSTEM DESCRIPTION AND INSTALLATION MANUAL**  
TCAS 3000 Traffic Alert and Collision Avoidance System

Selection of code 0005 displays the second of three pages that define the Program Pins status. See Figure 6–7.

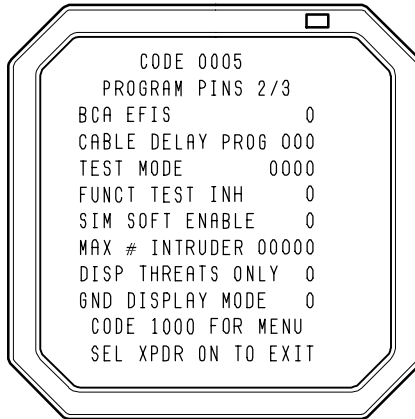

AD-53901,SH6@

**Figure 6–7. Typical Program Pins 2/3 Page**

Programming pins on the TCAS computer associated with each of the functions defined on the Program Pins 2/3 page are listed below. Where more than one program pin is indicated, the listed connector pins correspond to the display digits read from left to right. A one (1) indicates the associated pin is grounded. A zero (0) indicates open.

BCA EFIS	0	RA/TA block transfer program that determines the type of data transfer from the TCAS CU to the TA/RA displays: A (1) indicates ACSS BCA EFIS format. A (0) indicates ARINC 735 format: RMP-12C.
CABLE DELAY PROG	000	RF delay compensation program for antenna cable length difference (top versus bottom): RBP-7G, RBP-7H, RBP-7J
TEST MODE	0000	Shop test function (all 0s for flight mode): RBP-9D, RBP-9E, RBP-9F, RBP-9G
FUNCT TEST INH	0	Inhibits cockpit self-test when airborne (0 for no inhibit): RBP-8E
SIM SOFT ENABLE	0	Simulator Software Enable input: RBP-10K Should always be (0) for flight mode
MAX # INTRUDER	00000	Select maximum number of traffic symbols displayed on VSI. Value for each digit, from left to right, is 16, 8, 4, 2, 1. The maximum number is the sum of not selected values (0s): RBP-8F, RBP-8G, RBP-8H, RBP-8J, RBP-8K.
DISP THREATS ONLY	0	Selects display of traffic only when TAs or RAs occur: (0 indicates display of any traffic): RBP-7F.
GND DISPLAY MODE	0	Selects TCAS OFF automatically with aircraft ON GROUND (0 indicates TCAS active ON GROUND): RBP-7E.



**SYSTEM DESCRIPTION AND INSTALLATION MANUAL**  
TCAS 3000 Traffic Alert and Collision Avoidance System

Selection of code 0006 displays the third of three pages that define the Program Pins status. See Figure 6-8.

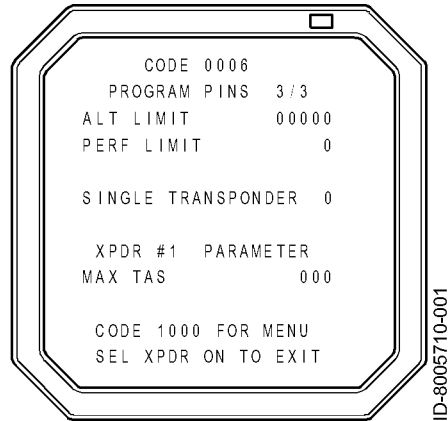

**Figure 6-8. Typical Program Pins 3/3 Page**



**SYSTEM DESCRIPTION AND INSTALLATION MANUAL**  
TCAS 3000 Traffic Alert and Collision Avoidance System

Programming pins on the TCAS computer associated with each of the functions defined on the Program Pins 3/3 page are listed below. Where more than one program pin is indicated, the listed connector pins correspond to the display digits read from left to right. A one (1) indicates the associated pin is grounded and a zero (0) indicates open, except for RCZ-852 MAX TAS where a one (1) indicates an open and a zero (0) indicates a ground.

ALT LIMIT	00000	Shows selected altitude above which TCAS will not give CLIMB commands. Value for each digit, from left to right, is 32000, 16000, 8000, 4000, and 2000 feet. Altitude is the sum of selected values (1s): RMP-6J, RMP-6H, RMP-6G, RMP-6F, RMP-6E.
PERF LIMIT	0	Selects CLIMB command altitude limit control from external performance computer: A ground (1) indicates performance/climb rate is not limited. An open (0) indicates performance/climb rate is limited: RMP-6D.
SINGLE TRANS-PONDER	0	Shows if the TCAS 3000 is configured for a single transponder. (1) indicates a single transponder. (0) indicates not a single transponder.
MAX TAS	000	Shows the selected maximum airspeed operating range of aircraft. This data is obtained from ARINC label 276 of the selected transponder. Refer to the appropriate Mode S transponder installation manual.
<b>NOTE:</b>	Line 8 of the Program Pins 3/3 display indicates which transponder is currently selected.	



**SYSTEM DESCRIPTION AND INSTALLATION MANUAL**  
TCAS 3000 Traffic Alert and Collision Avoidance System

(7) Help Reference Page

Selection of code 0007 displays the Help Reference page, Figure 6–9. This page serves as a reference to assist aircraft maintenance personnel in checking the functionality of dual transponders.

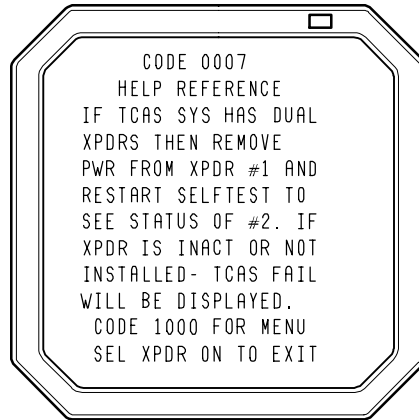

AD-53901,SH8@

**Figure 6–9. Help Reference Page**

In addition to the recommended procedure, the number 2 transponder must be selected on the Mode S/TCAS control panel and the mode select switch placed in TA only or TA/RA mode momentarily prior to restarting self-test to enter extended maintenance mode.



## SYSTEM DESCRIPTION AND INSTALLATION MANUAL

### TCAS 3000 Traffic Alert and Collision Avoidance System

#### (8) Suppression Bus Fail Page

The Suppression Bus Fail page, Figure 6–10, is displayed only when a TCAS suppression bus failure is indicated and the 4096 Ident Code is 0010. This page displays information about detected suppression bus failures. It briefly describes the problem and instructs maintenance personnel to change the 4096 Ident Code to display the Suppression Bus Clear page for clearing instructions. If there is no suppression bus failure, the main menu (0000) is displayed.



AD-53901,SH9@

**Figure 6–10. Suppression Bus Fail Page**

The flight crew may report a unique problem of an intruder displayed which appears to be co–altitude, located on the own aircraft symbol. In many of these cases, TCAS may issue a TA followed by an RA. After the flightcrew has initiated the advisory, the intruder may not appear to change relative to the own aircraft symbol.

In this type of report, a failure in the mutual suppression bus, which connects the own aircraft transponder to the TCAS CU, could result in the TCAS CU developing an intruder track file on its own associated transponder. Simply performing a DC continuity test of the connection between the TCAS CU and the transponders may not identify the problem. In many cases, a connector termination or pushed back pin may be the cause.

That is why it is very important to be monitoring the suppression signal from the active source, on both ends. The following is one method to monitor the signal. Remove the TCAS CU and the non–selected transponder. With an oscilloscope, monitor the signal at the TCAS CU rack rear connector for the Mode S transponder suppression signal related to the squitter message sent every second by the selected operational transponder.

Repeat the same test with the second transponder after removing the first transponder. To test the TCAS CU suppression pulse, install the TCAS CU, remove the No. 1 transponder and monitor the TCAS suppression pulse during the time of the UF16 broadcast or the WSS while in the air (if possible). This TCAS suppression signal should also be present on the No. 2 transponder.





**SYSTEM DESCRIPTION AND INSTALLATION MANUAL**  
TCAS 3000 Traffic Alert and Collision Avoidance System

(9) Suppression Bus Clear Page

The Suppression Bus Clear page, Figure 6-11, is displayed only when a TCAS suppression bus failure is indicated and the 4096 Ident Code is 0510. This page briefly describes how to clear suppression bus failures from the fault record by exiting the extended test mode with this page displayed. When the TCAS extended test is exited, the failure indication is cleared and a Suppression Bus Clear code is recorded in the current flight leg.



AD-53901,SH10@

**Figure 6-11. Suppression Bus Clear Page**

(10) Antenna Port Status Page

Selection of code 0011 displays the Antenna Port Status page, Figure 6-12. This page displays the current operational status of the top and bottom TCAS antennas. The status of each port is indicated as PASS when valid and FAIL when invalid. Information lines 8, 9, and 10 are not displayed when an omnidirectional bottom antenna is installed.

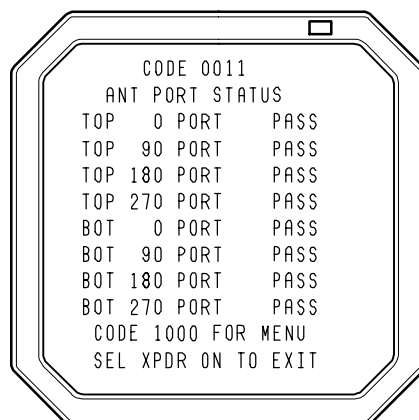

AD-53901,SH11@

**Figure 6-12. Typical Antenna Port Status Page**



**SYSTEM DESCRIPTION AND INSTALLATION MANUAL**  
TCAS 3000 Traffic Alert and Collision Avoidance System

(11) Option Pins Status Page

Selection of code 0012 displays a page that defines the TCAS computer option pins. See Figure 6-13.

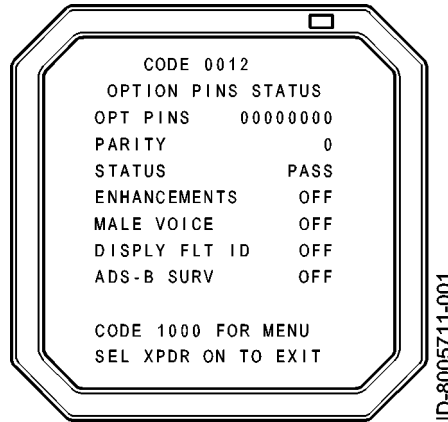

**Figure 6-13. Typical Option Pins Status Page**

Option pins on the TCAS computer associated with each of the functions defined on the Option Pins Status page are listed below. Where more than one option pin is indicated, the listed connector pins correspond to the display digits read from left to right.

There are eight option pins available on the TCAS computer for selection of various options. The OPT PINS are as follows: RMP-10G, -10H, -10J, -10K, -11A, -11B, -11C, and -11D.

**NOTE:** OPT PINS RMP-10G, -10H, -10J, and -10K are reserved for future enhancements and are used for parity check only.

The PARITY line (line 4) displays the status of the parity program pin (RMP-12G). Pin RMP-12G must be grounded (1) when the number of OPT PINS grounded is an odd number (1, 3, 5, 7). If number of OPT PINS grounded is an even number (0, 2, 4, 6, 8), then pin RMP-12G should be open (0).

The STATUS line (line 5) displays FAIL if the option pins parity is incorrect or PASS if parity is correct.

The ENHANCEMENTS line (line 6) displays the status of the Flight Data Recorder ARINC 429 and Extended Maintenance Log Program input status (Pin RMP-11D). This option enables the use of the Flight Data Recorder and the down loading of the extended maintenance log through a PDL connected to connector J1 located on the front of the TCAS computer. If pin RMP-11D is open, the Flight Data Recorder is not used and normal RA display bus operation occurs. If pin RMP-11D is grounded, high speed ARINC 429 flight data is output on the RA Display #1 and #2 busses and maintenance log data can be downloaded through a portable data loader.



## SYSTEM DESCRIPTION AND INSTALLATION MANUAL

TCAS 3000 Traffic Alert and Collision Avoidance System

The MALE VOICE line (line 7) displays the Male Voice Program input status (Pin RMP-11C). This option allows audio annunciation to be selectable for either male or female gender. If pin RMP-11C is grounded, the male voice option is enabled (ON). If pin RMP-11C is open, the female voice option is enabled (OFF).

The DISPLAY FLT ID line (line 8) displays the Flight ID Program input status (Pin RMP-11B). This program allows flight identification from the transponder to be output on traffic display busses. If pin RMP-11B is grounded, Flight ID Display is enabled (ON). If pin RMP-11B is open, Flight ID Display is disabled (OFF).

The ADS-B SURV line (line 9) displays the ADS-B surveillance program input status (Pin RMP-10K). This program allows the passive tracking of intruders who squitter ADS-B squitters containing position information. If pin RMP-10K is grounded, the ADS-B surveillance option is enabled (ON). If pin RMP-10K is open, the ADS-B surveillance option is disabled (OFF). To activate this option, the TCAS CU must also have hardware MOD C installed.

### (12) Part Numbers Page

Selection of code 0013 displays the Part Numbers Page, Figure 6-14. This page displays the software part numbers loaded on the TCAS Computer.

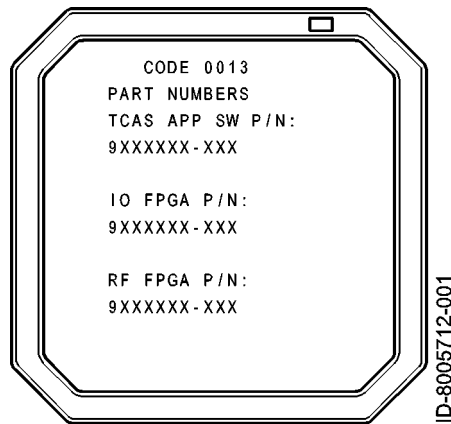

Figure 6-14. Typical Option Pins Status Page

### E. TCAS Computer Unit Self-Test

The TCAS computer unit detects system faults and displays them on its front panel annunciators. Its flight leg memory stores system status and fault information for 10 consecutive flight legs. A flight leg is the interval between weight-off-wheels and weight-on-wheels during which TCAS is operative. By recalling the stored data, ground maintenance personnel can evaluate in-flight performance on the ground and fault isolate a current or previous failure to a specific LRU or LRU interface.

Table 6-3 summarizes how the TCAS computer unit self-test is activated at power-up, during operation, and during commanded self-test. The computer unit can activate the commanded self-test only when the aircraft is on the ground.



**SYSTEM DESCRIPTION AND INSTALLATION MANUAL**  
TCAS 3000 Traffic Alert and Collision Avoidance System

Table 6–4 lists the functions of the computer unit’s status annunciators and the corresponding troubleshooting actions. If the annunciators indicate an antenna problem, the antenna connections should be checked by measuring the antenna resistance values at the computer unit mounting tray. The resistance values listed in Table 6–5 are measured between the center conductor and shield on each LTP and LMP antenna connector.

**Table 6–3. Computer Unit Self-Test Execution**

<b>Test Sequence</b>	<b>Activation</b>	<b>Test Indications</b>
Power On Self-Test	Self-Test is activated with each application of system power	No indication unless a fault is detected. System status/fault data is stored in memory for 10 consecutive flight legs. Data can be recalled by doing the commanded self-test on the ground.
Continuous Self-Test	Executed automatically as part of normal TCAS inflight operation	No indication unless a fault is detected. System status/fault data is stored in memory for 10 consecutive flight legs. Data can be recalled by doing the commanded self-test on the ground.
Commanded Self-Test	Push the front panel PUSH TO TEST button	<ul style="list-style-type: none"> <li>• All front panel lamps come on during a 3-second lamp test.</li> <li>• If the TCAS is operational, the TCAS PASS green lamp comes on for a 10-second display period and then goes off.</li> <li>• If the TCAS is not operational, one or more red fault lamps come on for a 10-second display period. Refer to Table 6–4 for corrective action.</li> </ul>
	Push the PUSH TO TEST button again before the previous 10-second display period has elapsed	<ul style="list-style-type: none"> <li>• Previous fault display is aborted</li> <li>• All lamps come on during a 1-second lamp test</li> <li>• Status/fault data recorded during the preceding flight leg is displayed for 10-seconds.</li> </ul>
	Push the PUSH TO TEST button before the end of each succeeding display period	<ul style="list-style-type: none"> <li>• Status/fault data recorded during a total of 10 flight legs (maximum) is displayed</li> <li>• When data from the earliest recorded flight leg has been displayed, all lamps flash at a 2.5-Hz rate for 3-seconds if the PUSH TO TEST button is pushed. This indicates the end of recorded test data.</li> </ul>



**SYSTEM DESCRIPTION AND INSTALLATION MANUAL**  
TCAS 3000 Traffic Alert and Collision Avoidance System

**Table 6-4. Computer Unit Fault Reporting and Corrective Actions**

<b>Status Annunciator</b>	<b>Failure</b>	<b>Possible corrective Action</b>
TCAS PASS	The TCAS Computer Unit passes its own internal BITE test	TCAS computer unit is operational. If other annunciators are on, the problem is in the indicated subsystem or aircraft wiring.
TCAS FAIL	The TCAS Computer Unit has failed its own internal BITE test	Replace the TCAS computer unit.
TOP ANT	The top antenna DC resistance test indicates a failure	Remove the TCAS computer unit. Use a multimeter to measure the DC resistances indicated in Table 6-5 for the top antenna. Repair antenna cables or replace the antenna as required.
BOT ANT	The bottom antenna DC resistance test indicates a failure	Remove the TCAS computer unit. Use a multimeter to measure the DC resistance indicated in Table 6-5 for the bottom antenna. Repair antenna cable(s) or replace the antenna as required.
HDG	Heading input function not used	Not applicable
TA DISP	Traffic advisory display discrete signals No.1 or No.2 indicate a failure	Check wiring and power to TA display. (On both sides of the cockpit, if two are installed.) Make sure that RA/TA valid discrete 1 and 2 (RMP-7E and RMP-7J) are <3.5 V dc to ground. Repair wiring or replace display as required.
RA DISP	Resolution advisory display discrete signals No.1 or No.2 indicate a failure	Check wiring and power to RA displays. Make sure that RA valid discrete 1 and 2 (RMP-14C and RMP-13E) are <3.5 V dc to ground. Repair wiring or replace display as required.
RAD ALT	Radio altitude source No.1 or No.2 is invalid or has failed	Check wiring and power to the radio altimeters. For analog radio altimeters, make sure the RAD ALT No.1 and No.2 valid discrete (RMP-2K and RBP-3C) are >18.5 V dc. Repair wiring or replace radio altimeter as required.
XPDR BUS	Mode S Transponder No.1 or No.2 is invalid or has failed.	Check wiring and power to the transponders. Check for data on XT 429 bus No.1 and No.2 (RMP-14F/G and RMP-14H/J). Repair wiring or replace transponder as required. If the Single Mode S Transponder program pin (RMP-10D) is not grounded in installations. Computer Units, a XPDR Bus Fault may be displayed.
ATT	Attitude input function not used.	Not applicable



**SYSTEM DESCRIPTION AND INSTALLATION MANUAL**  
TCAS 3000 Traffic Alert and Collision Avoidance System

**F. Directional Antenna Test / Fault Isolation Procedure**

**NOTE:** These procedures are recommended only if a TCAS computer bite or extended test failure of the top or bottom directional antenna has occurred.

- (1) Review extended maintenance or flight leg BITE data to determine which antenna has failed.
- (2) Remove TCAS computer unit from mounting tray. Visually examine all antenna coax cable connectors at the mounting tray side as well as the LRU connectors. Remove any foreign material discovered and reinstall the LRU.
- (3) Do a system self-test to determine if the fault has cleared. If the failure continues, remove the TCAS computer unit and proceed.
- (4) Do a continuity test at the LRU end of each antenna cable. The resistance values should be as specified in Table 6-5.
- (5) If an open circuit, short circuit, or unacceptable resistance measurement is detected on the directional antenna path, a failure has occurred in the connector, coax cable, or directional antenna.
- (6) Locate the directional antenna that has a suspected failure. Remove the coax cable from the antenna port that is suspected to have failed. Isolate which section of the antenna system is at fault by a process of elimination. The resistance values of the antenna ports should be as specified in Table 6-5.
- (7) Remove and replace the appropriate failed component in accordance with approved Aircraft Maintenance Manual procedures.

**Table 6-5. Antenna Wiring Resistance**

Antenna	Connector Section	Pin	DC Resistance
Top Directional Antenna	LTP	1	1000 ± 100 Ohms
		2	8060 ± 800 Ohms
		3	4020 ± 400 Ohms
		4	2000 ± 200 Ohms
Bottom Directional Antenna	LMP	1	1000 ± 100 Ohms
		2	8060 ± 800 Ohms
		3	4020 ± 400 Ohms
		4	2000 ± 200 Ohms
Optional Bottom Omnidirectional Antenna	LMP	1	0 to 50 Ohms (50 Ohms maximum)
		2	Infinite (>50K Ohms)
		3	Infinite (>50K Ohms)
		4	Infinite (>50K Ohms)



**SYSTEM DESCRIPTION AND INSTALLATION MANUAL**  
TCAS 3000 Traffic Alert and Collision Avoidance System

- NOTE:** The procedures that follow are recommended for intermittent antenna system failures or if the continuity tests have not identified a failed component in the antenna system or if the flight crew detects an unacceptable visual discrepancy between an intruder aircraft and its displayed location.
- (8) If the displayed location of an intruder aircraft is believed to be in error, appropriate ramp test equipment can be used to simulate intruder aircraft to check the suspected discrepancy while on the ground.
  - (9) Remove the suspected TCAS directional antenna and terminate the antenna side of the cable with a 50 ohm termination (Omni-Spectra Part Number 3102-6100-00 or equivalent TNC jack with VSWR  $\leq 1.15 : 1$ ).
  - (10) Perform a thorough inspection for moisture or contamination of all coax cable assemblies.
  - (11) Remove the TCAS LRU and do a VSWR check on the coax cable from the TCAS computer tray side. Use approved VSWR test equipment and operating procedures. The measured VSWR should be less than 2.0 : 1.
  - (12) If the VSWR test fails, isolate failed antenna coax section. Remove/repair appropriate cable and/or connector.
  - (13) If VSWR test complies, return the directional antenna to the manufacturer for further testing. Install a new directional antenna in accordance with Aircraft Maintenance Manual procedures.



**SYSTEM DESCRIPTION AND INSTALLATION MANUAL**  
 TCAS 3000 Traffic Alert and Collision Avoidance System

**MAINTENANCE PRACTICES**

**1. General**

This section provides instructions for removing, reinstalling, and adjusting each LRU of the TCAS 3000 that has been previously installed by the aircraft manufacturer or completion center. Where applicable, instructions for replacing lamps, knobs, and set screws are included. Adjustment information is called out as required.

**CAUTION: SHOULD ANY INSTALLATION CRITICAL CASES ARISE WITH THE REINSTALLATION OF ANY UNIT, YOU MUST COMPLY 100 PERCENT WITH THE INSTRUCTION.**

**CAUTION: TO PREVENT DAMAGE TO EQUIPMENT, TURN AIRCRAFT POWER OFF WHEN REMOVING OR INSTALLING LRUS.**

When removing or installing any TCAS LRU, prepare the aircraft for safe ground maintenance. Open and tag all applicable system circuit breakers.

**2. Equipment and Materials**

**CAUTION: BEFORE YOU USE A MATERIAL, REFER TO THE MANUFACTURERS' MATERIAL SAFETY DATA SHEETS FOR SAFETY INFORMATION. SOME MATERIALS CAN BE DANGEROUS.**

Maintenance materials identified with a ACSS Material Number (AMN) are given in Table 7- 1.

**Table 7- 1. Materials**

Name	Description	Source
HMN 9722878	Sealing compound, temperature-resistant, high-adhesion, two component, polysulfide synthetic rubber (MIL-S-8802, Type I - dichromate cured sealing materials, Class B1/2 - spreadable) — PR-1422 (base and accelerator)	Courtaulds Aerospace, Glendale, CA

**NOTES:**

1. Equivalent alternatives are permitted for materials in this list.
2. The HMN codes in the list of materials identify the HMN given to each material.

No additional special equipment or materials, other than those commonly used in the shop, are required to install the units in existing trays and clamps, and to adjust the system. Do not over tighten mounting screws. Where torque values are not given, it is acceptable to finger tighten the mounting screws.





**SYSTEM DESCRIPTION AND INSTALLATION MANUAL**  
TCAS 3000 Traffic Alert and Collision Avoidance System

### **3. Procedure for the TCAS 3000 Computer Unit**

#### **A. Removal and Installation Procedure**

- (1) Remove the TCAS computer unit.
  - (a) Loosen mounting tray hold-down knobs.
  - (b) Slowly pull forward on the computer unit handle to separate computer unit and mounting tray connectors. The computer unit is now free to be removed from the mounting tray.
  - (c) Place electrostatic protective covers on the computer unit and the mounting tray electrical connectors.
- (2) Reinstall the TCAS computer unit.
  - (a) Remove protective plastic covers from aircraft connectors. Remove electrostatic protective covers from computer unit electrical connectors.
  - (b) Slide computer unit into mounting tray.

**CAUTION: DO NOT FORCE FIT. IF MATING IS DIFFICULT, REMOVE THE COMPUTER UNIT AND EXAMINE THE CONNECTOR FOR PINS THAT ARE BENT OR OUT OF ALIGNMENT. ALSO CHECK THE ALIGNMENT OF THE RECEPTACLE IN THE MOUNTING TRAY.**

- (c) Carefully apply firm pressure until the computer unit connectors mate with the connector receptacles on the mounting tray.
- (d) Tighten mounting tray hold-down knobs to make sure all connectors are fully engaged.

#### **B. Adjustment Procedure**

Not Applicable.

#### **C. Repair Procedure**

Not Applicable.

#### **D. Return to Service Procedures**

Do the Return to Service Test Procedures referenced in the ADJUSTMENT/TEST section of this manual.



**SYSTEM DESCRIPTION AND INSTALLATION MANUAL**  
TCAS 3000 Traffic Alert and Collision Avoidance System

## 4. Procedure for the Directional Antenna

### A. Removal and Installation Procedure

- (1) Remove the directional antenna.
  - (a) If applicable, use a phenolic scraper to remove aerodynamic sealant around periphery of antenna.
  - (b) Remove four or eight (quantity depends on dash number of antenna) non-Torx drive screws used to attach antenna to fuselage. See Figure 2-6 for location and number of mounting holes for each dash number antenna.
  - (c) Carefully lift antenna from fuselage avoiding any damage to the coaxial cables.
  - (d) Disconnect coaxial cables from antenna connectors J1, J2, J3, and J4.
  - (e) Put protective covers on the aircraft coaxial cable connectors and the antenna coax connectors.
- (2) Reinstall the directional antenna.
  - (a) If applicable, remove any existing aerodynamic sealant from antenna and clean antenna mounting area.
  - (b) Put supplied o-ring in antenna o-ring groove. If antenna is supplied with a Teflon gasket, install gasket between antenna and fuselage.
  - (c) Remove protective covers from antenna and aircraft coaxial mating connectors.
  - (d) Examine antenna and coaxial mating connectors to make sure they are clean and secure.
  - (e) Orient antenna with respect to airframe (arrow painted on radome must point forward). Connect four aircraft coaxial cables to antenna. Refer to Figure 2-6 for wiring information. Note the color bands on the antenna connectors and cables: yellow = J1, black = J2, blue = J3, and red = J4.

**NOTE:** Do not apply a sealant between antenna base and fuselage. Application of a sealant will reduce lightning protection.
  - (f) Align antenna mounting holes with holes in fuselage (note the non-symmetric hole pattern).
  - (g) Attach antenna to fuselage with four or eight (quantity depends on dash number of antenna) non-Torx drive screws and flat washers. See tables 3 and 4 of Figure 2-6 for dash number mounting information. Apply a sealant to the screw threads before installing them. Torque mounting screws to  $22 \pm 3$  inch-pounds ( $2.5 \pm 0.2$  Newton-Meters).
  - (h) Apply an aerodynamic sealant around periphery of the antenna base to prevent seepage of water and condensation and to preclude corrosion.



**SYSTEM DESCRIPTION AND INSTALLATION MANUAL**  
TCAS 3000 Traffic Alert and Collision Avoidance System

**B. Adjustment Procedure**

Not Applicable.

**C. Repair Procedure**

The ACSS TCAS Directional Antenna is a non-repairable item. If the antenna is damaged or determined to be faulty, it must be replaced with a new antenna.

**D. Return to Service Procedures**

Do the Return to Service Test Procedures referenced in the ADJUSTMENT/TEST section of this manual.

**5. Procedure for the Omnidirectional Antenna**

**A. Removal and Installation Procedure**

(1) Remove the Omnidirectional Antenna.

- (a) If applicable, use a phenolic scraper to remove aerodynamic sealant around periphery of antenna baseplate.
- (b) If applicable, remove sealant from antenna mounting screw holes.
- (c) Remove retaining screws used to attach antenna to aircraft fuselage.
- (d) Carefully pull antenna from fuselage.
- (e) Disconnect coaxial cable from antenna connector.
- (f) Put protective covers on the aircraft coaxial cable connector and the antenna connector.

(2) Reinstall the Omnidirectional Antenna.

- (a) If applicable, remove any existing aerodynamic sealant from antenna mounting surface and clean antenna mounting area.
- (b) Remove and clean sealant from baseplate and baseplate cutout.
- (c) Remove protective covers from antenna and coaxial cable connectors.
- (d) Examine antenna and coaxial cable connectors to make sure they are clean and secure.
- (e) Connect aircraft coaxial cable to antenna connector.
- (f) Apply a coating of sealant under heads of antenna mounting screws and position antenna on fuselage mounting surface. Attach antenna to fuselage with mounting screws.
- (g) Apply an aerodynamic sealant around the periphery of the antenna baseplate.



**SYSTEM DESCRIPTION AND INSTALLATION MANUAL**  
TCAS 3000 Traffic Alert and Collision Avoidance System

**B. Adjustment Procedure**

Not Applicable.

**C. Repair Procedure**

Most omnidirectional antennas are non-repairable. If the antenna is damaged or determined to be faulty, it must be replaced with a new antenna.

**D. Return to Service Procedures**

Do the Return to Service Test Procedures referenced in the ADJUSTMENT/TEST section of this manual.

**6. Procedure for the Control Panel**

**A. Removal and Installation Procedure**

(1) Remove the Control Panel.

(a) Disengage Dzus fasteners on control panel.

(b) Pull control panel out of aircraft mounting location and disconnect aircraft cable connectors. Control panel is now free to be removed from aircraft.

(c) Put electrostatic protective covers on control panel and aircraft mating electrical connectors.

(2) Reinstall the Control Panel.

(a) Remove protective covers from control panel and aircraft mating connectors.

(b) Connect aircraft cables to control panel connectors J1 and J2.

(c) Insert control panel into mounting location.

(d) Engage Dzus fasteners on the control panel to attach it to aircraft structure.

**B. Adjustment Procedure**

Not Applicable.

**C. Repair Procedure**

Any repair procedures should be in accordance with the manufacturer's repair instructions.

**D. Return to Service Procedures**

Do the Return to Service Test Procedures referenced in the ADJUSTMENT/TEST section of this manual.



**SYSTEM DESCRIPTION AND INSTALLATION MANUAL**  
TCAS 3000 Traffic Alert and Collision Avoidance System

## **7. Procedure for the VSI/TRA Display**

### **A. Removal and Installation Procedure**

(1) Remove the VSI/TRA Display.

(a) Loosen screws of instrument panel mounting clamp.

**NOTE:** Most installation clamps require the top screws be loosened to remove the instrument. Other clamps require the diagonal screws be loosened. Refer to the aircraft maintenance manual (AMM) for specific application.

(b) Pull the VSI/TRA out of the instrument panel and disconnect J1 mating connector.

(c) Put electrostatic protective covers on display and aircraft mating electrical connectors.

(2) Reinstall the VSI/TRA Display.

(a) Remove protective covers from display and aircraft mating connectors.

(b) Connect aircraft cable to VSI/TRA connector J1.

(c) Insert the display into the instrument panel and push all the way back against panel.

(d) Tighten the four instrument mounting clamp screws.

### **B. Adjustment Procedure**

Not Applicable.

### **C. Repair Procedure**

Not Applicable.

### **D. Return to Service Procedures**

Do the Return to Service Test Procedures referenced in the ADJUSTMENT/TEST section of this manual.



**SYSTEM DESCRIPTION AND INSTALLATION MANUAL**  
TCAS 3000 Traffic Alert and Collision Avoidance System

## **8. Procedure for the Pressure Transducer Module**

### **A. Removal and Installation Procedure**

- (1) Remove the Pressure Transducer Module.
  - (a) Disconnect aircraft electrical mating connector from PTM connector J1.
  - (b) Disconnect pneumatic fitting from PTM.
  - (c) Loosen the two captive fasteners used to attach the PTM to its mounting bracket or plate and remove unit.
- (2) Reinstall the Pressure Transducer Module.
  - (a) Attach PTM to mounting bracket or plate with two captive screws.
  - (b) Connect pneumatic line to fitting on PTM.
  - (c) Connect aircraft electrical cable to PTM connector J1.

### **B. Adjustment Procedure**

Not Applicable.

### **C. Repair Procedure**

Not Applicable.

### **D. Return to Service Procedures**

Do the Return to Service Test Procedures referenced in the ADJUSTMENT/TEST section of this manual.



**SYSTEM DESCRIPTION AND INSTALLATION MANUAL**  
TCAS 3000 Traffic Alert and Collision Avoidance System

## **9. Procedure for the Transponder**

### **A. Removal and Installation Procedure**

(1) Remove Transponder

- (a) Loosen mounting tray hold-down knobs.
- (b) Slowly pull forward on the unit handle to separate transponder and mounting tray connectors. The transponder is now free to be removed from the mounting tray.
- (c) Place electrostatic protective covers on the transponder and the mounting tray electrical connectors.

(2) Reinstall Transponder

- (a) Remove protective plastic covers from mounting tray connectors and transponder electrical connectors.
- (b) Slide transponder into mounting tray.

**CAUTION: DO NOT FORCE FIT. IF MATING IS DIFFICULT, REMOVE THE UNIT AND EXAMINE THE CONNECTORS FOR PINS THAT ARE BENT OR OUT OF ALIGNMENT. ALSO CHECK THE ALIGNMENT OF THE RECEPTACLE IN THE MOUNTING TRAY.**

- (c) Carefully apply firm pressure until the transponder connectors mate with the connector receptacles on the mounting tray.
- (d) Tighten mounting tray hold-down knobs making sure all connectors are fully engaged.

### **B. Adjustment Procedure**

Not Applicable.

### **C. Repair Procedure**

Not Applicable.



**SYSTEM DESCRIPTION AND INSTALLATION MANUAL**  
TCAS 3000 Traffic Alert and Collision Avoidance System

**D. Return to Service Procedures**

- (1) For installations using serial data bus (ARINC 429) altitude data:
  - (a) The POST (automatic on power on) and PAST self test (initiated from the control panel) are the only required Return to Service tests for the transponder.
  - (b) After the transponder passes these tests, the appropriate logbook entries may be made and the unit is ready for use.
- (2) For installations using parallel (Gillham code) altitude data:
  - (a) The POST (automatic on power on) and PAST self test (initiated from the control panel) must be passed.
  - (b) Connect an air data tester to the aircraft pitot/static system and set up a transponder ramp tester.
  - (c) Setup the air data tester to output the following altitudes. The transponder's encoded altitude must correspond.
    - 11,700 feet
    - 24,400 feet
    - 30,800 feet.

**NOTE:** These three altitudes check the operation of all parallel altitude wires.

- (d) After the transponder passes these tests, the appropriate logbook entries may be made and the unit is ready for use.





**SYSTEM DESCRIPTION AND INSTALLATION MANUAL**  
TCAS 3000 Traffic Alert and Collision Avoidance System

**10. Instructions for Continued Airworthiness, FAR Part 25.1529**

Maintenance requirements and instructions for Continued Airworthiness of the TCAS 3000 Traffic Alert and Collision Avoidance System components are contained in the paragraphs that follow:

Installation of the TCAS 3000 on an aircraft by Supplemental Type Certificate or Form 337 obligates the aircraft operator to include the maintenance information provided by this manual in the operator's AMMI and the operator's Aircraft Scheduled Maintenance Program.

- A. Maintenance information for the TCAS 3000 (system description, removal, installation, testing, etc.) is contained in this manual.
- B. LRU part numbers and other necessary part numbers contained in this manual should be placed into the aircraft operator's appropriate aircraft illustrated parts catalog (IPC).
- C. Wiring diagram information contained in this manual should be placed into the aircraft operator's appropriate aircraft Wiring Diagram Manuals.
- D. The TCAS 3000 components are considered on-condition units and no additional maintenance is required other than a check for security and operation at normal inspection intervals.
- E. If a system component is inoperative, remove unit, secure cables and wiring, collar applicable switches and circuit breakers, and placard them inoperative. Revise equipment list and weight and balance as applicable prior to flight and make a log book entry that unit was removed (refer to FAR Part 91.213 or the aircraft's Minimum Equipment List [MEL]).
- F. The TCAS 3000 components can be repaired only at a factory authorized repair center or an appropriately rated FAA Part 145 repair station.
- G. Once repaired, reinstall the LRU in the aircraft in accordance with the original Form 337 approved data or instructions in this manual. Do a Return to Service test of the system and approve it for return to service with a log book entry in accordance with the requirements specified in FAR Part 43.9.



**SYSTEM DESCRIPTION AND INSTALLATION MANUAL**  
TCAS 3000 Traffic Alert and Collision Avoidance System

H. Scheduled maintenance program tasks to be added to the aircraft operator's appropriate aircraft maintenance program are as follows:

- (1) Recommended periodic scheduled servicing tasks: None required.
- (2) Recommended periodic inspections are as follows:
  - The TCAS directional antennas used with the TCAS 3000 should be removed and the underlying structure inspected for deterioration and corrosion during zonal inspections usually performed in conjunction with heavy maintenance D checks.
  - The ATC transponder(s) used with this system have test and inspections that are required by FAR 91.413 to be completed every 24 months.
- (3) Recommended periodic scheduled preventative maintenance tests (Tests to determine system condition and/or latent failures):
  - The ACSS TCAS 3000 Computer Unit is designed to detect its own failures as well as failures external to the computer unit itself. This BITE is continuously being executed on a periodic basis. No formal periodic maintenance is required for the TCAS computer unit or the VSI/TRA display.
  - The ACSS RCZ-852 Diversity Mode S Transponder is designed to detect its own failures. This BITE is continuously being executed on a periodic basis. No formal periodic maintenance is required for the transponder other than the 24 month recertification test required by FAR 91.413.



**SYSTEM DESCRIPTION AND INSTALLATION MANUAL**  
TCAS 3000 Traffic Alert and Collision Avoidance System

Blank Page



**SYSTEM DESCRIPTION AND INSTALLATION MANUAL**  
TCAS 3000 Traffic Alert and Collision Avoidance System

## **INSPECTION/CHECK**

### **1. General**

The visual check procedures that follow are recommended for the TCAS 3000 Traffic Alert and Collision Avoidance System components after they have been installed in the aircraft.

### **2. Equipment and Materials**

None

### **3. Procedure**

**CAUTION: BEFORE YOU DO ANY OF THE PROCEDURES THAT FOLLOW, MAKE SURE THAT ALL TCAS SYSTEM CIRCUIT BREAKERS ARE PULLED.**

#### **A. Check TCAS Computer Unit**

- (1) Visually examine all external surfaces for possible damage. Check dust cover and external connectors for dust, corrosion, or damage.
- (2) Check external parts for loose or damaged hardware.
- (3) Make visual check of wiring and connectors for damage.

#### **B. Check Antennas**

- (1) Visually examine all external surfaces for possible damage.
- (2) Check cabling for breaks, burned areas, and damaged insulation.

#### **C. Check Control Panel**

- (1) Visually examine all external surfaces for possible damage.
- (2) Check external parts (connectors, control knobs, annunciators) for looseness or damage.
- (3) Check that controller is securely mounted (Dzus fasteners properly engaged).
- (4) Check controls for smooth, positive action.



**SYSTEM DESCRIPTION AND INSTALLATION MANUAL**  
TCAS 3000 Traffic Alert and Collision Avoidance System

**D. Check VSI/TRA Display**

- (1) Visually examine all external surfaces for possible damage. Check dust cover and external connector for dust or damage.
- (2) Check that display is securely mounted (locking mechanism is properly engaged).
- (3) Check that LCD glass is not scratched or cracked.

**E. Check Transponders**

- (1) Visually examine all external surfaces for possible damage. Check dust cover and external connectors for dust, corrosion, or damage.
- (2) Check external parts for loose or damaged hardware.
- (3) Make visual check of wiring and connectors for damage.



**SYSTEM DESCRIPTION AND INSTALLATION MANUAL**  
TCAS 3000 Traffic Alert and Collision Avoidance System

## **CLEANING/PAINTING**

### **1. General**

While the TCAS 3000 Traffic Alert and Collision Avoidance System is installed in the aircraft, cleaning is limited to the procedures given below. Painting and more extensive cleaning should be done during shop maintenance when the LRUs can be disassembled. Detailed instructions are given in each applicable component-level maintenance manual.

### **2. Equipment and Materials**

**WARNING: BEFORE YOU USE A MATERIAL, REFER TO THE MANUFACTURERS' MATERIAL SAFETY DATA SHEETS FOR SAFETY INFORMATION. SOME MATERIALS CAN BE DANGEROUS.**

Table 9-1 gives the equipment and materials required for cleaning and painting.

**Table 9-1. Equipment and Materials**

<b>Name</b>	<b>Description</b>	<b>Source</b>
Abrasive paper	No. 600, nonconductive abrasive	Optional source
Air supply	Air ionizing nozzle gun attachment for compressed air (20 psi)	Optional source
Cleaning brush	Soft, natural-bristle (camel's hair)	Optional source
Glass cleaner	Ammoniated	Optional source
Lens tissue	Non-linting	Optional source
Sandpaper	Grit sizes 220 and 400	Optional source
AMN 110C878	Catalyst, polyurethane — No. V66V44(-4)	Sherwin-Williams Co, Cleveland, OH
AMN 110C978	Reducer, polyurethane — No. R7K84	Sherwin-Williams Co, Cleveland, OH
AMN 1130778	Solvent — Isopropyl alcohol (99%), semigrade	Optional source
AMN 6008676	Lint free cloth — Bluewipes, No. TX512	Texwipe Co, Upper Saddle River, NJ



**SYSTEM DESCRIPTION AND INSTALLATION MANUAL**  
TCAS 3000 Traffic Alert and Collision Avoidance System

**Table 9-1. Equipment and Materials (cont)**

<b>Name</b>	<b>Description</b>	<b>Source</b>
AMN 94C2178	Coating, Prolane 2.8TPLUS polyurethane, semigloss WHT, FED-STD-595, Color No. 27925 — No. F63EXW968-4380	Sherwin-Williams Co, Cleveland, OH
AMN 9460078	Primer, coating, epoxy, low VOC (MIL-P-23377, Type I, Class 2)	Optional source
<b>NOTES:</b> <ol style="list-style-type: none"><li>1. Equivalent alternatives are permitted for equipment and materials in this list.</li><li>2. The AMN codes in the list of materials identify the ACSS Material Number (AMN) given to each material.</li></ol>		

### 3. Cleaning

**CAUTION: IF YOU CLEAN ELECTROSTATIC SENSITIVE COMPONENTS WITH PRESSURIZED AIR, MAKE SURE THE HOSE HAS AN AIR IONIZING NOZZLE OR GUN. AN ELECTROSTATIC CHARGE CAN CAUSE DAMAGE TO THE LRU COMPONENT PARTS IF THE NOZZLE OR GUN ATTACHMENT IS NOT USED.**

#### A. Clean TCAS Computer Unit and Mounting Tray

- (1) Loosen mounting tray hold-down clamps and pull TCAS computer unit out of mounting tray.
- (2) Clean mounting tray with cloth or brush dampened with solvent, then dry with cloth or compressed air.
- (3) Clean all dust and foreign matter from front panel and cover air vents with a clean cloth or brush dampened with solvent or clean with compressed air.

#### B. Clean Antennas

Clean antennas with a cloth dampened with solvent. Dry with a clean cloth or use compressed air.

#### C. Clean Control Panel

- (1) Clean dust and foreign matter from cover and connectors with a brush dampened with solvent, then dry with a clean cloth or compressed air.
- (2) Clean front of control panel with a mild glass cleaner and soft cotton cloth.



**SYSTEM DESCRIPTION AND INSTALLATION MANUAL**  
TCAS 3000 Traffic Alert and Collision Avoidance System

**D. Clean VSI/TRA Display**

- (1) Clean front panel of display with a mild glass cleaner and soft cotton cloth.
- (2) Clean the glass face with a mild glass cleaner and lens tissue.

**E. Clean Transponders**

Clean transponders with a cloth dampened with solvent. Dry with a clean cloth or use compressed air.

**4. Painting**

**A. TCAS Directional Antennas**

- (1) Scope

This procedure covers the removal and re-application of coating to the TCAS directional antenna. Localized touch-up is allowable and preferred using airbrush techniques to ensure minimal paint thickness. The touch-up may be applied either with the antenna on the aircraft or removed from the aircraft.

- (2) Procedure

**WARNING: SOLVENTS AND COATINGS ARE COMBUSTIBLE. KEEP AWAY FROM HEAT AND OPEN FLAME.**

- (a) Clean

Scrape away all filleting and adhesive material from area to be coated. Remove surface contamination using isopropyl alcohol or reducer.

- (b) Scuff Sand

If the entire antenna is to be recoated, sand to primer with 220 grit sandpaper. An orbital sander is preferred. For localized touch-up, feather sand areas of exposed radome material to provide a smooth transition to the painted surface.

- (c) Final Sand

If the entire antenna is to be recoated, sand primer and through-holes using 400 grit sandpaper or Scotch-Brite so the primer is removed except in swirls wherever possible.

- (d) Final Clean

Clean the surface to be coated with isopropyl alcohol or reducer.





**SYSTEM DESCRIPTION AND INSTALLATION MANUAL**  
TCAS 3000 Traffic Alert and Collision Avoidance System

(e) Prime

**NOTE:** The pot life of the primer after mixing components is 8 hours.

- 1 Cover each Torx screw head with an adhesive dot to prevent paint from being applied to the screw heads.
- 2 Mix epoxy primer components in a 1:1 ratio under slow agitation.
- 3 Allow 15 minutes before spraying.
- 4 Spray one light coat – wet film thickness of 1.5 mils.
  - Viscosity – 18 to 20 seconds No. 2 Zahn test
  - Gun orifice – 363–A needle or equivalent
  - Fluid pressure – 5 to 10 psi recommended
  - Air pressure – 50 psi recommended.

(f) Primer Cure

Allow the primer to air dry for a minimum of one hour and a maximum of 4 hours before applying the top coat.

(g) Paint

- 1 Mix paint in a base (coating) to catalyst ratio of 6:1 under slow agitation.

**NOTE:** The percentage of reducer used can vary to meet the applicable color standard.

- 2 Spray one light tack coat and allow to dry 15 minutes.
  - Viscosity – 20 to 22 seconds No. 2 Zahn test
  - Gun orifice – 363–A needle or equivalent
  - Fluid pressure – 5 to 10 psi recommended
  - Air pressure – 50 psi recommended.
- 3 Apply final top coat – total wet film thickness of 3.5 to 4.0 mils.

(h) Drying Cycle

The antenna must air dry overnight or be baked at 85 degrees Celsius for 30 minutes minimum before flying. Remove the adhesive dots from the heads of the Torx screws.

(3) Performance Verification Testing

Perform a ramp test per approved aircraft maintenance procedure on the TCAS system to ensure the bearing accuracy is within specification after the coating application.



**SYSTEM DESCRIPTION AND INSTALLATION MANUAL**  
TCAS 3000 Traffic Alert and Collision Avoidance System

**B. Other TCAS System LRUs**

Except for minor touch up, painting should only be done after the LRU has been removed from the aircraft or during shop maintenance. Painting procedures and materials are given in the applicable LRU component maintenance manual (CMM).



**SYSTEM DESCRIPTION AND INSTALLATION MANUAL**  
TCAS 3000 Traffic Alert and Collision Avoidance System

Blank Page



**SYSTEM DESCRIPTION AND INSTALLATION MANUAL**  
TCAS 3000 Traffic Alert and Collision Avoidance System

## REPAIRS

### 1. General

Major repairs to the TCAS 3000 system components are made only during shop maintenance when the equipment is removed from the aircraft. Detailed instructions for repair and adjustment of each of the repairable LRUs are presented in the applicable component maintenance manuals given in Table 10-1.

**Table 10-1. LRU Maintenance Manual**

<b>LRU</b>	<b>ACSS Component Maintenance Manual (CMM)</b>	<b>ATA Number</b>
TCAS 3000 Computer Unit Part No. 7517900-10YYY, -55YYY, 71YYY	A09-3841-002	34-43-11
Control Panel Part No. 4052190-902, -904, -906, -908	15-3841-01	34-43-01
Control Panel Part No. 4052190-903, -905, -907, -909	15-3841-03	34-43-05
VSI/TRA Indicator Part No. 4067241-8XX	15-2254-01	22-54-01
Pressure Transducer Module Part No. 4067487-901	15-3841-06	34-43-03
XS-950 Mode S Data Link Transponder Part No. 7517800-XXYYY	A09-3839-002	34-52-08
RCZ-852 Diversity Mode S Transponder Part No. 7510700-850	A09-3800-15	23-81-01



**SYSTEM DESCRIPTION AND INSTALLATION MANUAL**  
TCAS 3000 Traffic Alert and Collision Avoidance System

Blank Page