

Installing the LGCell

This section contains the following:

- Section 9.1 Inspecting Shipment 9-2
- Section 9.2 Installing the Main Hub 9-3
- Section 9.2.5 Connecting Multiple LGCell Systems 9-14
- Section 9.3 Installing the Expansion Hub 9-17
- Section 9.4 Installing the Remote Access Unit 9-25



CAUTION: Although modeled after an Ethernet/LAN architecture, LGCell units are not intended to be connected to Ethernet data hubs, routers, or other similar data equipment.

NOTE: Only LGC Wireless personnel and approved Certified Installation Service Provider (CISP) personnel are authorized to install LGCell systems. Frequency bands are licensed for use by wireless operators.

9.1 Inspecting Shipment

Follow this procedure before installing LGCell equipment:

1. Verify the number of packages received against the packing list.
2. Check all packages for external damage; report any external damage to the shipping carrier. If there is damage, a shipping carrier agent should be present before unpacking and inspecting the contents because damage caused during transit is the responsibility of the shipping agent.
3. Open and check each package against the packing slip. If any items are missing, contact LGC Wireless customer service.
4. Do not remove items from antistatic packing until you are ready to install them. If damage is discovered at the time of installation, contact the shipping agent.

9.2 Installing the Main Hub

9.2.1 Main Hub Installation Checklist

✓	Installation Requirement	Consideration
	Floor Plans	Installation location of equipment clearly marked
	Main Hub	Same frequency and protocol as Expansion Hub(s)
	AC power available	Power cord is 2 m (6.5 ft) long <ul style="list-style-type: none"> • 117V AC, 0.3 amp @ 60 Hz • 230V AC, 0.15 amp @ 50 Hz
	Rack space available	4.4 cm (1.75 in.) high
	Clearance for air circulation	7.6 cm (3 in.) front and rear
	Suitable operating environment	0° to 45°C (32° to 113°F) 5% to 95% non-condensing humidity
Donor Antenna-to-LGCell Configuration		
	Donor Antenna	Installed, inspected; N-male to N-male coaxial cable to lightning arrestor/surge suppressor
	Lightning Arrestor or Surge Suppressor	Installed between roof-top antenna and repeater; N-male to N-male coaxial cable
	Repeater	Installed between lightning arrestor/surge suppressor and Main Hub; N-male to N-male coaxial cable
Base Station-to-LGCell Configuration		
	Microcellular Base Station	Verify RF power (see tables in Section 7.1); N-male to N-male coaxial cable; installed, inspected Attenuation may be required to achieve the desired RF output per carrier at the RAU
Cascading multiple Main Hubs		
	Power combiner/divider	N-male to N-male coaxial cables; power combiner/divider to Main Hub and base station or repeater
Cabling		
	Coax (Simplex)	Coax approved; N-type male unidirectional connectors; repeater or base station to Main Hub
	Coax (Duplex)	Coax approved; N-type male, bidirectional connectors; repeater or base station to Main Hub
	MMF	62.5µm/125µm; ST optical connectors, male; up to 1 km (3300 ft); Main Hub to Expansion Hubs

Continued on next page

Installing the LGCell

✓	Installation Requirement	Consideration
	Distances	
	Main Hub is within 3–6m (10–20 ft) of connecting repeater	If longer distance, determine the loss of the cable used for this connection and adjust the RF signal into the Main Hub accordingly. This can be done by readjusting the power from the base station, or by changing the attenuation value between the base station/repeater and the Main Hub.
	Main Hub is within 3–6m (10–20 ft) of connecting base station	
	Main Hub is within 1 km (3300 ft) of Expansion Hub(s); 3 dB optical link budget	
	Miscellaneous	
	Cable manager	Rack space immediately above or below the Main Hub; 8.9 cm (3.5 in.) high

9.2.2 Tools and Materials Required to Install Main Hub

The tools and materials required to install the Main Hub are listed in the following table.

✓	Description
	Philips screwdriver
	Mounting screws and spring nuts
	Power cord
	Fiber cleaning supplies (optical grade alcohol and lint-free wipes)
	Compressed air (optical grade)

9.2.3 Main Hub Installation Procedures

Procedures in this section:

- Installing the Main Hub in a Rack 9-5
- Connecting Power and Powering Up 9-6
- Installing an Optional Cable Manager in a Rack 9-6
- Connecting the MMF cables 9-7
- Check the Main Hub Functionality LEDs 9-8
- Check the Main Hub MMF Port LEDs 9-8
- Connecting a Main Hub to a Roof-top Antenna 9-9

Installing the Main Hub in a Rack

The Main Hub (1U high) mounts in a standard 19 in. (48.3 cm) equipment rack. Allow front and rear clearance of 7.6 cm (3 in.) for air circulation.

The Main Hub is shipped with #10-32 mounting screws. Another common rack thread is #12-24. Confirm that the mounting screws match the racks threads.

1. Insert spring nuts into rack where needed or use existing threaded holes.
2. Place the Main Hub into the rack from the front.
3. Align the flange holes with the spring nuts installed in Step 1.
4. Insert the mounting screws in the appropriate positions in the rack.
5. Tighten the mounting screws.

✓ Connecting Power and Powering Up

After mounting the Main Hub in the rack, connect AC power. You may use multiple outlet surge protectors for multiple Main Hubs.

1. Connect the AC power cord to the Main Hub (labeled 1 on the following figure).
2. Plug the power cord into an outlet providing AC power.

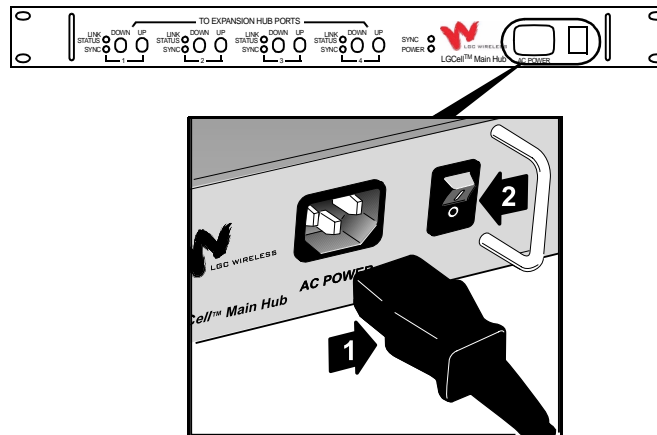

3. Flip the Main Hub's power switch from position **0** to position **1** (labeled 2 on the figure above.)
The front panel unit functionality LEDs, **POWER** and **SYNC**, should be green (lit).

✓ Installing an Optional Cable Manager in a Rack

- Fasten the cable manager to the rack, immediately above or below the Main Hub, using screws.

✓ Connecting the MMF cables

Before connecting the MMF cables, confirm that the optical loss does not exceed 3 dB optical.

If fiber distribution panels are used, confirm that the total optical loss of fiber cable, from the Main Hub through distribution panels and patch cords to the Expansion Hub, does not exceed 3 dB optical.

Connect all MMF cables (two per port) to the MMF ST female optical connectors (labeled **DOWN** and **UP**) on the Main Hub front panel. Use any available Main Hub port.

To clean the fiber ports:

Use compressed air to blow dust out of each fiber port before you insert the ST optical connector. Note that compressed air should not leave any residue as this will contaminate the fiber port.

To clean the fiber connectors:

Be sure that the MMF cable ST optical connectors are clean and free of dust or oils. If the fiber connector front face is not free of dust or oils, follow the manufacturer's recommendations for cleaning it.

To connect the MMF cables:

The MMF cable is labeled with either **1** or **2**, or is color-coded. This differentiates the connectors for proper connection between the Main Hub and Expansion Hubs.

If the fiber jumper is labeled with **1** or **2**:

1. Connect **1** to **UP** on Main Hub.
2. Connect **2** to **DOWN** on Main Hub.
3. Record which cable number you connected to **UP** and **DOWN**.

This information is needed when connecting the other end of the MMF cable to the Expansion Hub ports.

If the fiber jumper is color-coded (for example, "blue" or "red"):

1. Connect "blue" to **UP** on Main Hub.
2. Connect "red" to **DOWN** on Main Hub.
3. Record which cable color you connected to **UP** and **DOWN**.

This information is needed when connecting the other end of the MMF cable to the Expansion Hub ports.

✓ **Check the Main Hub Functionality LEDs**

The unit functionality LEDs (**POWER** and **SYNC**) should be green. If not, cycle the power to reset the Main Hub.

✓ **Check the Main Hub MMF Port LEDs**

The MMF port LEDs (**LINK STATUS** and **SYNC**) should be red. This indicates that the other end of the MMF cable is not yet connected to the Expansion Hub ports.

NOTE: Refer to Section 10 for troubleshooting LEDs.

NOTE: You do not have to use all of the MMF ports on the Main Hub. Unused ports do not need to be terminated. Free ports can be used for future growth and to manage changes in the in-building system.

9.2.4 Interfacing LGCell to Base Stations



WARNING: Exceeding the maximum input power could cause failure of the Main Hub (refer to Section 7.1 on page 7-3 for maximum power ratings). Attenuators may be required to limit the maximum composite power into the Main Hub.

✓ Connecting a Main Hub to a Roof-top Antenna

LGC Wireless recommends that you use a lightning arrestor or surge protector in a roof-top antenna configuration. Insert the lightning arrestor or surge protector between the roof-top antenna and the repeater that is connected to the Main Hub.

1. Connect an N-male to N-male coaxial cable to the roof-top antenna.
2. Connect the other end of the N-male to N-male coaxial cable to the grounded surge suppressor.
3. Connect an N-male to N-male coaxial cable to the grounded surge suppressor.
4. Connect the other end of the N-male to N-male coaxial cable to the repeater.
5. Connect an N-male to N-male coaxial cable to the repeater.
6. Connect the other end of the N-male to N-male coaxial cable to the circulator 1 connector.
7. Connect an N-male to N-male coaxial cable to the circulator 2 connector.
8. Connect the other end of the N-male to N-male coaxial cable to the **FORWARD** simplex connector on the Main Hub.

Attenuation may be required to achieve the desired RF output at the RAU.

9. Connect an N-male to N-male coaxial cable to the circulator 3 connector.
10. Connect the other end of the N-male to N-male coaxial cable to the **REVERSE** simplex connector on the Main Hub.

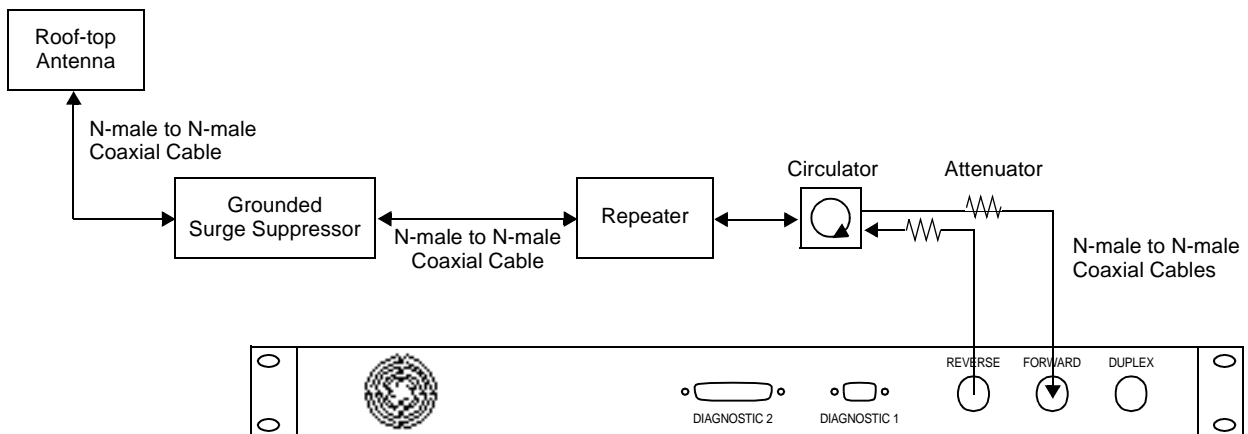

✓ Connecting a Main Hub to an In-Building Base Station

Connecting a Simplex Base Station to a Main Hub:

1. Connect an N-male to N-male coaxial cable to the transmit simplex connector on the base station.
2. Connect the other end of the N-male to N-male coaxial cable to the **FORWARD** simplex connector on the Main Hub.
3. Connect an N-male to N-male coaxial cable to the receive simplex connector on the base station.
4. Connect the other end of the N-male to N-male coaxial cable to the **REVERSE** simplex connector on the Main Hub.

Figure 9-1 Simplex Base Station to LGCell Main Hub

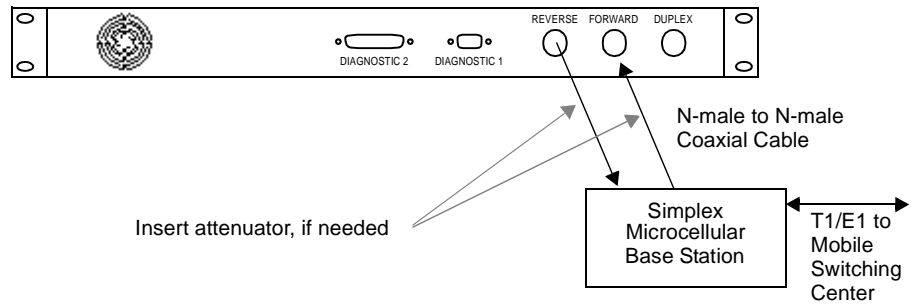

Connecting a Duplex Base Station to a Main Hub:

When connecting to a duplex base station, it is recommended that you use a circulator and connect to the simplex ports on the Main Hub.

You can insert attenuators between the base station and circulator, and between the circulator and Main Hub as needed; refer to Section 7.5.1 on page 7-45 for more information.

1. Connect an N-male to N-male coaxial cable to the duplex connector on the base station.
2. Connect the other N-male connector to a circulator.
3. Connect an N-male to N-male coaxial cable to the **FORWARD** simplex connector on the Main Hub.
4. Connect the other end of the N-male coaxial cable to the transmit connector on the circulator.
5. Connect an N-male to N-male coaxial cable to the **REVERSE** simplex connector on the Main Hub.
6. Connect the other end of the N-male coaxial cable to the receive connector on the circulator.

Figure 9-2 Duplex Base Station to LGCell Main Hub

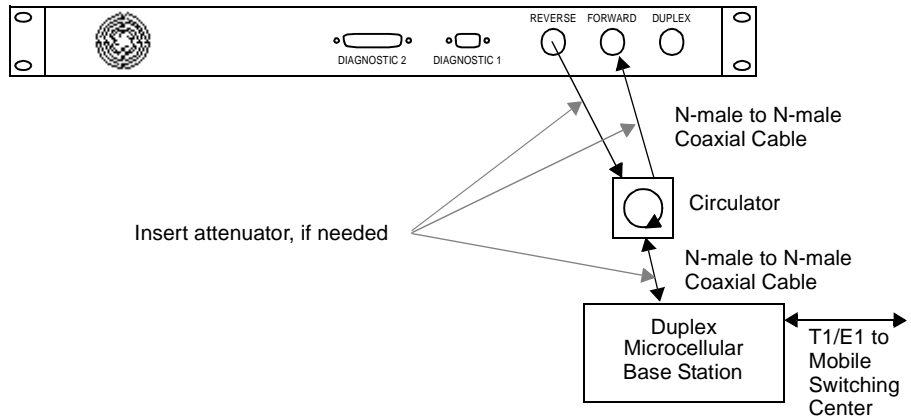

✓ Using the Duplex Port to Increase Gain on the Uplink

Because some types of LGCells have duplex ports with gains of 0, 30, or 40 dB, depending on the frequency and protocol, you can use the simplex forward port for the downlink signals and the duplex port for the uplink signals when gain on the uplink is desired. Duplex port gain is shown in the table in Figure 9-3.

Connecting a Duplex Base Station to the LGCell Duplex/Simplex Ports:

1. Connect an N-male to N-male coaxial cable to the duplex connector on the base station.
2. Connect the other N-male connector to a circulator.
3. Connect an N-male to N-male coaxial cable to the **FORWARD** simplex connector on the Main Hub.
4. Connect the other end of the N-male coaxial cable to the transmit connector on the circulator.
5. Connect an N-male to N-male coaxial cable to the **DUPLEX** connector on the Main Hub.
6. Connect the other end of the N-male coaxial cable to the receive connector on the circulator.

Figure 9-3 Duplex Base Station to LGCell Main Hub

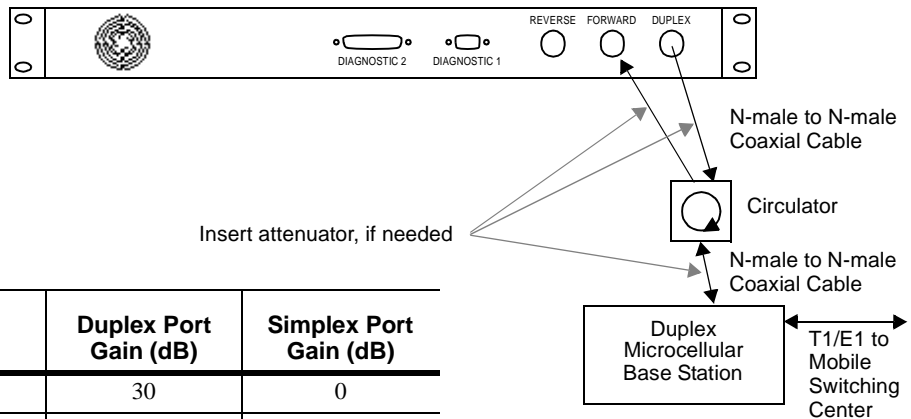

LGCell Frequency/Format	Duplex Port Gain (dB)	Simplex Port Gain (dB)
800 MHz AMPS, TDMA	30	0
800 MHz CDMA	30	0
800 MHz iDEN	0	0
900 MHz GSM / EGSM	0	0
1800 MHz DCS/GSM	0	0
1900 MHz TDMA	40	0
1900 MHz CDMA	40	0
1900 MHz GSM	40	0

Connecting a Simplex Base Station to the LGCell Duplex/Simplex Ports:

1. Connect an N-male to N-male coaxial cable to the transmit connector on the base station.
2. Connect the other end of the N-male coaxial cable to the **FORWARD** simplex connector on the Main Hub.
3. Connect an N-male to N-male coaxial cable to the receive connector on the base station.
4. Connect the other end of the N-male coaxial cable to the **DUPLEX** connector on the Main Hub.

Figure 9-4 Duplex Base Station to LGCell Main Hub

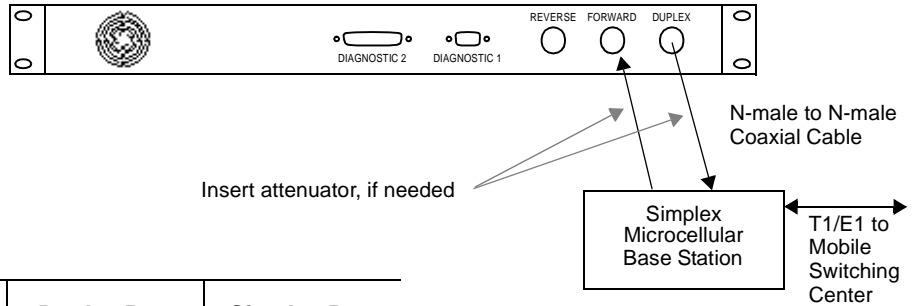

LGCell Frequency/Format	Duplex Port Gain (dB)	Simplex Port Gain (dB)
800 MHz AMPS, TDMA	30	0
800 MHz CDMA	30	0
800 MHz iDEN	0	0
900 MHz GSM / EGSM	0	0
1800 MHz DCS/GSM	0	0
1900 MHz TDMA	40	0
1900 MHz CDMA	40	0
1900 MHz GSM	40	0

9.2.5 Connecting Multiple LGCell Systems

You can use power combiners/dividers as dividers to connect multiple LGCells in order to increase the total number of RAUs in a system. You can use power combiners/dividers to combine base station channels in order to increase the number of RF carriers the system transports.

9.2.5.1 Connecting Two LGCells

Connecting two LGCells increases the total number of supportable RAUs from 16 to 32. Two Main Hubs support up to eight Expansion Hubs which in turn support up to 32 RAUs.

The following equipment is required:

- A 2x1 or 2x2 hybrid power combiner/divider
- 3 N-male to N-male coaxial jumper cables

Figure 9-5 Connecting Two LGCell Main Hubs using their Duplex Ports

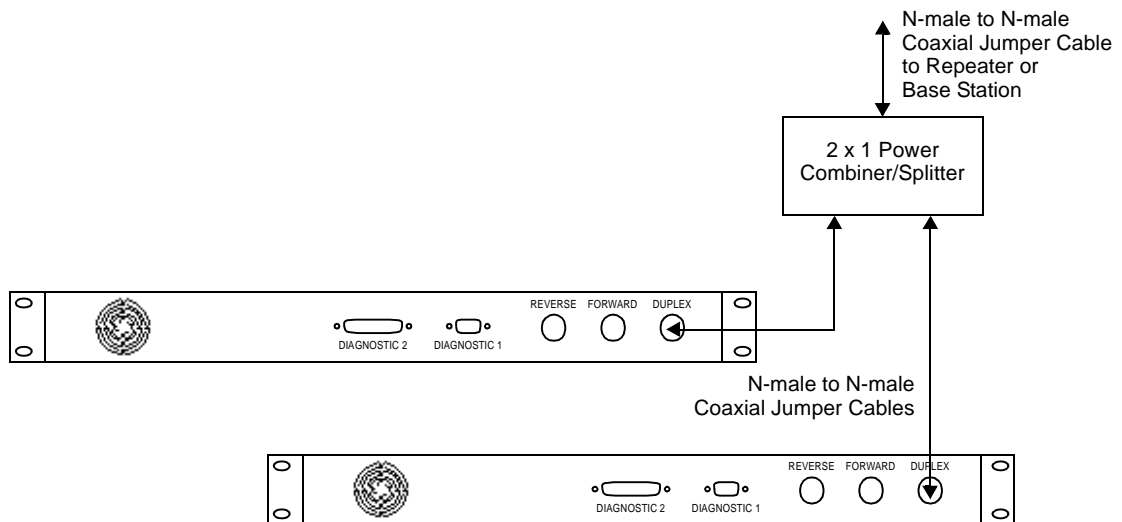

✓ Connecting Two LGCells

1. Connect the **DUPLEX**, **FORWARD**, or **REVERSE** connector of one of the Main Hubs to an input/output port on the power combiner/divider using an N-male to N-male coaxial cable jumper.
2. Connect the **DUPLEX**, **FORWARD**, or **REVERSE** connector of the second Main Hub to the second input/output port on the power combiner/divider using an N-male to N-male coaxial cable jumper.
3. Connect the combined port of the power combiner/divider to an base station or a repeater using an N-male to N-male coaxial cable jumper.
4. Check the Main Hub LEDs.
After connecting the LGCells, check all Main Hub LEDs to ensure that the system is operating properly.

9.2.5.2 Connecting More Than Two LGCells

Repeat this procedure to connect any number of LGCell systems. For three systems, use a 3x1 power combiner/divider, and so on.

NOTE: When you are connecting multiple LGCells to the **FORWARD** and **REVERSE** simplex ports, you will have to use a power combiner/divider for each direction. Terminate each unused power combiner/divider port with a 50 ohm terminator.

9.2.6 Installing Main Hubs in a Neutral Host System

Installing Main Hubs in a neutral host system is the same as described in Section 9.2.3 on page 9-5.

We recommend mounting all neutral host system Main Hubs in the same rack(s), grouped by frequency or carrier. For example, group the Main Hubs for the iDEN carrier(s) together, then the 800 MHz cellular carrier(s), and so on.

Connecting to base stations and repeaters is the same as described in Section 9.2.4 on page 9-9 and Section 9.2.5 on page 9-14.

9.3 Installing the Expansion Hub

9.3.1 Expansion Hub Installation Checklist

✓	Installation Requirement	Consideration
	Floor Plans	Installation location of equipment clearly marked
	Expansion Hub	Same frequency and protocol as Main Hub
	AC power available	Power cord is 2 m (6.5 ft) long <ul style="list-style-type: none"> • 117V AC, 0.70 amp @ 60 Hz • 230V AC, 0.35 amp @ 50 Hz
	Rack space or wall mount location available	4.4 cm (1.75 in.) high, 1U; Clearance: 3 in. front and rear
	Suitable operating environment	0° to 45°C (32° to 113°F) 5% to 95% non-condensing humidity
	Cabling	
	Cat-5 UTP/STP	TIA/EIA 568-A approved; RJ-45 male connectors; Expansion Hub to RAUs <ul style="list-style-type: none"> • Absolute Minimum: 10 meters (33 ft) • Recommended Minimum: 20 meters (66 ft) • Maximum: 50 meters (165 ft)
	MMF	62.5µm/125µm; ST optical connectors, male; up to 1 km (3300 ft); Expansion Hub to Main Hub
	Distances	
	Expansion Hub is within 1 km (3300 ft) of Main Hub (see Table 7-25 on page 7-29 if different MMF length)	
	Expansion Hub is within 10 m to 50 m (33 ft to 165 ft) of RAUs (see Table 7-25 on page 7-30 if different length)	

9.3.2 Tools and Materials Required to Install Expansion Hub

The tools and materials required to install the Expansion Hub are listed in the following table.

✓	Description
	Philips screwdriver
	Mounting screws and spring nuts
	Power cord
	Optional L brackets: Used to mount Expansion Hub to wall. (PN 4310 – single, PN 4311 – double)
	6 anchors and 6 screws, or other suitable hardware (not provided): Used to attach L brackets to wall (3 for each bracket).
	Fiber cleaning supplies (optical grade alcohol and lint-free wipes)
	Compressed air (optical grade)

9.3.3 Expansion Hub Installation Procedures

Procedures in this section:

- Installing the Expansion Hub 9-18
- Connecting Power and Powering Up 9-20
- Connect the MMF cables 9-21
- Check the Expansion Hub Unit Functionality LEDs 9-22
- Check the Expansion Hub MMF Port LEDs 9-22
- Connect UTP/STP cables from the RAUs 9-23

✓ Installing the Expansion Hub

The Expansion Hub (1U high) can mount in a standard 19 in. (48.3 cm) equipment rack or attach to a wall.

The Expansion Hub is shipped with #10-32 mounting screws. Another common rack thread is #12-24. Confirm that the mounting screws match the rack's threads.

Installing the Expansion Hub in a rack:

1. Insert spring nuts into the rack where needed or use existing threaded holes.
2. Place the Expansion Hub into the rack from the front.
3. Align the flange holes with the spring nuts installed in Step 1.
4. Insert the mounting screws in the appropriate positions in the rack.
5. Tighten the mounting screws.

Mounting the Expansion Hub to a wall:

1. Attach the L brackets to the Expansion Hub.

Using the screws that came with the Expansion Hub, attach the L brackets to the Expansion Hub's rack-mounting holes.

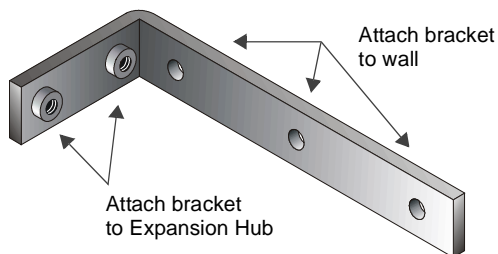

2. Hold the Expansion Hub to the wall in the position where it will be mounted and mark the pre-punched L bracket holes onto the wall for drilling.

Refer to the following figure for wall mounting options.

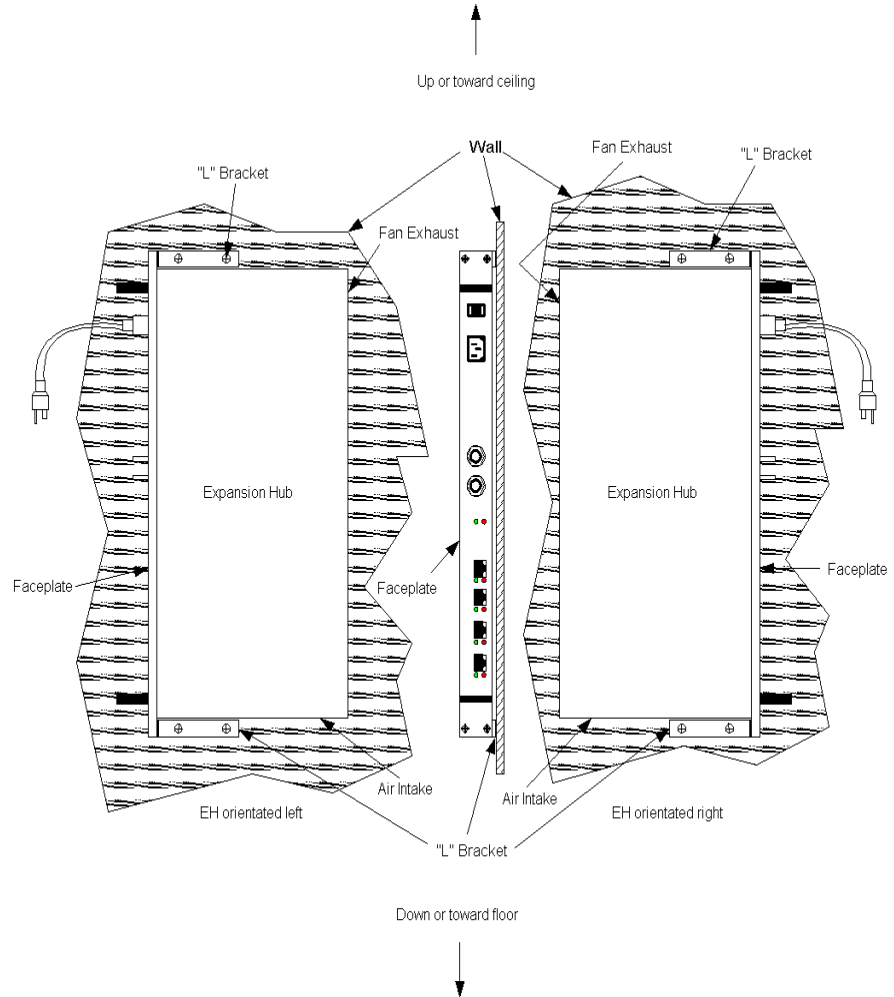

3. Drill the screw holes in the wall and insert the anchors.
4. Attach the Expansion Hub to the wall with the screws.

CAUTION: Mounting the Expansion Hub facing up exposes the connectors to falling dust and debris. Mounting it facing down exposes the fan to falling dust and debris.

✓ Connecting Power and Powering Up

After mounting the Expansion Hub, connect the AC power.

1. Connect the AC power cord to the Expansion Hub (labeled 1 on the following figure).
2. Plug the power cord into an outlet providing AC power.

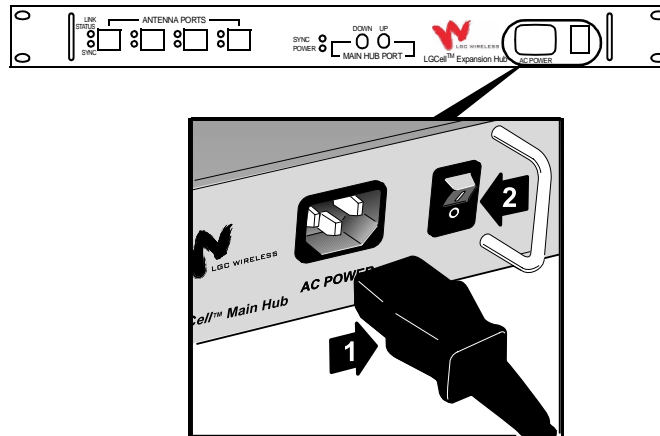

3. Flip the Expansion Hub's power switch from position 0 to position 1 (labeled 2 on the figure.)

The front panel **POWER** LED should be green (lit) and the unit **SYNC** LED should be off.

 **Connect the MMF cables**

Before connecting the MMF cables, confirm that the optical loss does not exceed 3 dB optical.

If fiber distribution panels are used, confirm that the total optical loss of fiber cable, from the Main Hub through distribution panels and patch cords to the Expansion Hub, does not exceed 3 dB optical.

Connect all MMF cables from the Main Hub to the Expansion Hub(s).

To clean the fiber ports:

Use compressed air to blow dust out of each fiber port before you insert the ST optical connector. Note that compressed air should not leave any residue as this will contaminate the fiber port.

To clean the fiber connectors:

Be sure that the MMF cable ST optical connectors are clean and free of dust or oils. If the fiber connector front face is not free of dust or oils, follow the manufacturer's recommendations for cleaning it.

To connect the MMF cables:

The MMF cable is labeled with either **1** or **2**, or is color-coded. This differentiates the connectors for proper connection between the Main Hub and Expansion Hubs. For proper connection between the Main Hub ports and the Expansion Hub ports, refer to the numbered or color-coded connections that were recorded when the Main Hub was installed.

If the fiber jumper is labeled with **1** or **2**:

1. Connect **1** to **UP** on Expansion Hub.
2. Connect **2** to **DOWN** on Expansion Hub.

If the fiber jumper is color-coded (for example, "blue" or "red"):

1. Connect "blue" to **UP** on Expansion Hub.
2. Connect "red" to **DOWN** on Expansion Hub.

✓ **Check the Expansion Hub Unit Functionality LEDs**

The unit functionality LEDs (**POWER** and **SYNC**) should be green if the Main Hub is on.

✓ **Check the Expansion Hub MMF Port LEDs**

The MMF port LEDs (**LINK STATUS** and **SYNC**) should be red. This indicates that the UTP/STP cable is not yet connected to the Remote Access Unit(s).

✓ **Check the Main Hub MMF Port LEDs**

The MMF port LEDs (**LINK STATUS** and **SYNC**) should be green.

NOTE: Refer to Section 10 for troubleshooting LEDs.

✓ **Connect UTP/STP cables from the RAUs**

Before connecting the UTP/STP cables, confirm that they meet TIA/EIA 568-A specifications (refer to Appendix B).

Connect all UTP/STP cables coming from the RAUs to any available RJ-45 connector on the Expansion Hub, as shown in the following figure. Make sure you connect RAUs that are of the correct frequency and protocol.

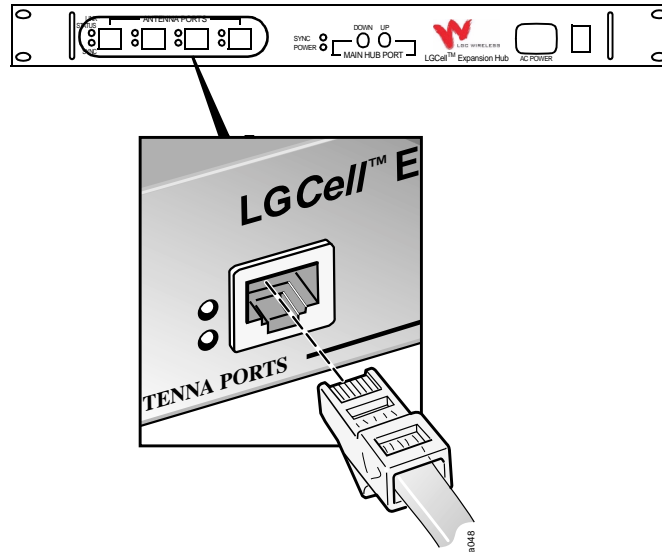

✓ **Check the Expansion Hub Cat-5 Port LEDs**

The Expansion Hub Cat-5 port **LINK STATUS** and **SYNC** LEDs should be green if the RAUs are connected on the other end of the UTP/STP cable.

The Cat-5 port LEDs should be red if the RAUs are not yet connected.

NOTE: Refer to Section 10 for troubleshooting LEDs.

NOTE: You do not have to use all of the Cat-5 ports on the Expansion Hub. Unused ports do not need to be terminated. Free ports can be used for future growth and to manage changes in the in-building system.

9.3.4 Installing Expansion Hubs in a Neutral Host System

Installing neutral host system Expansion Hubs is the same as described in Section 9.3.3 on page 9-18.

If rack-mounting the Expansion Hubs, we recommend mounting all neutral host system hubs in the same rack(s) or location, grouped by frequency or carrier. For example, group the Expansion Hubs for the iDEN carrier(s) together, then the 800 MHz cellular carrier(s), and so on.

9.4 Installing the Remote Access Unit

9.4.1 Remote Access Unit Installation Checklist

✓	Installation Requirement	Consideration
	Floor Plans	Installation location of equipment clearly marked
	Remote Access Unit(s)	4 per Expansion Hub
	Passive antennas	Coaxial cable terminated correctly
	Suitable operating environment	
	Cabling	
	Cat-5 UTP/STP	TIA/EIA 568-A approved; RJ-45 male connectors; RAU to Expansion Hub <ul style="list-style-type: none"> • Absolute Minimum: 10 meters (33 ft) • Recommended Minimum: 20 meters (66 ft) • Maximum: 50 meters (165 ft)
	Coaxial	Use low-loss cable; RAU (SMA male connector) to passive antennas; typical 1 m (3.3 ft) using RG142 coaxial cable
	Distance	
	RAU is within 10 m to 50 m (33 ft to 165 ft) of Expansion Hub (see Table 7-25 on page 7-30 if different UTP/STP length)	
	RAU is within RF-design distance of passive antenna, typically 1 m (3.3 ft); coverage will be affected if coaxial cable length differs from what was used to calculate the design plan	

9.4.2 Tools and Materials Required to Install Remote Access Unit

The tools and supplies required to install the RAU depends on the installation method selected; the following table lists suggestions.

✓	Description
	Philips screwdriver
	Tie Wraps
	Screws
	Drywall Anchors
	Pipe Clamp
	RAU Mounting Plate
	Drill

9.4.3 RAU Installation Procedures

Procedures in this section:

- Mounting RAUs 9-26
- Connecting the Antenna 9-28
- Installing Passive Antennas 9-28
- Connecting the UTP/STP Cable 9-29
- Check the RAU LEDs 9-30

✓ Mounting RAUs

Mount all RAUs in their assigned locations. Refer to the following figure for mounting options.

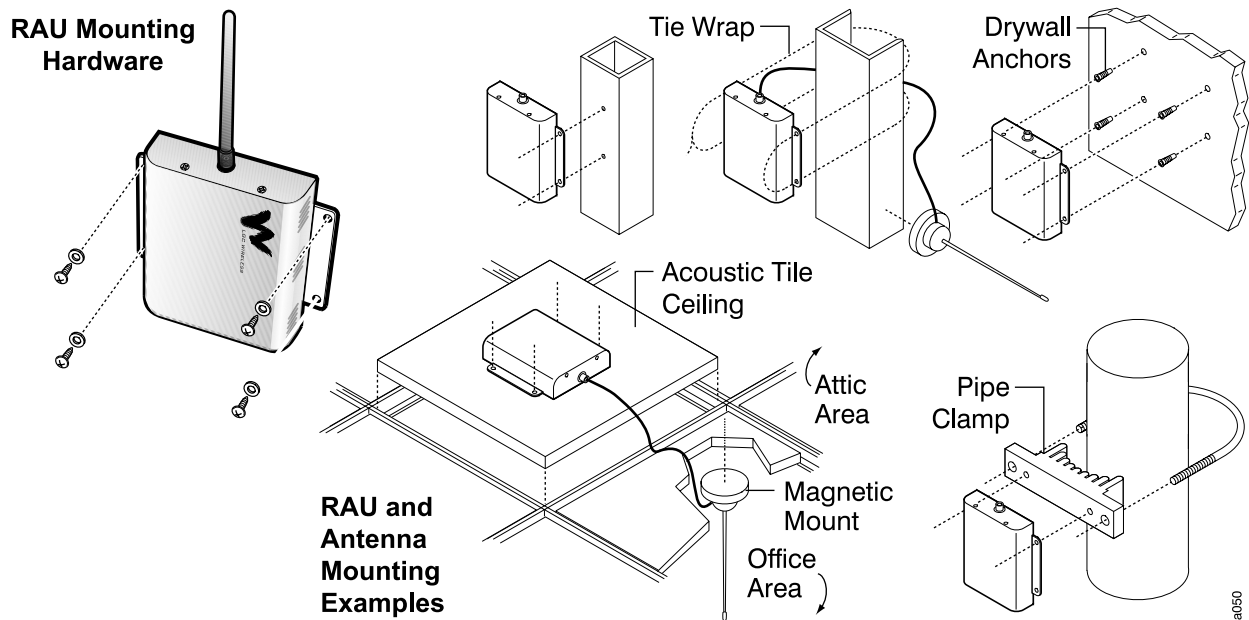

CAUTION: Install iDEN and 800 MHz cellular RAUs so that their antennas will be 6 to 8 meters (20 to 26 feet) apart. See Section 9.4.4 on page 9-31 for more information.

✓ Installing RAUs using a Mounting Plate

You can install up to four RAUs using a Quad-RAU Mounting Plate (LGC Wireless part number MP-RAU-4).

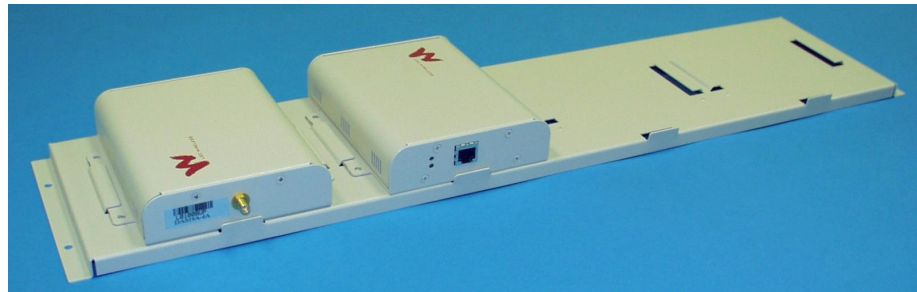

Installing RAUs on the Mounting Plate:

After the Mounting Plate is securely installed, you can attach up to four RAUs to it.

- Slide an RAU into a Mounting Plate slot so the edge of the RAU meets the tab on the Mounting Plate.

RAUs can be installed with either end against the tab.

Installing the Mounting Plate Above Ceiling Tile:

- Secure the mounting plate to the ceiling tile using the four screws.

Installing the Mounting Plate to the Wall:

1. Hold the mounting plate in position to the wall and mark the mounting plate's pre-drilled holes on the wall.
If installing the plate horizontally, make sure the supporting tabs are toward the floor so the installed RAUs will rest against them.
2. Drill four holes in the wall where you marked.
3. Insert drywall anchors into the drilled holes.
4. Insert a screw through one of the holes in the mounting plate and screw it into one of the drywall anchors.
5. Repeat step 4 for the other mounting holes.

✓ Installing Passive Antennas

Refer to the manufacturer's installation instructions to install passive antennas.

Passive antennas are usually installed below the ceiling. If they are installed above the ceiling, the additional loss due to the ceiling material must be considered when estimating the antenna coverage area.

Considerations:

- Use coaxial cable with the least amount of loss possible.
- **Keep iDEN and 800 MHz cellular antennas 6 to 8 meters (20 to 26 ft) apart.**

✓ Connecting the Antenna

Connect a passive antenna to the SMA female connector on the RAU. The following figure shows connecting an optional antenna to a single band RAU.

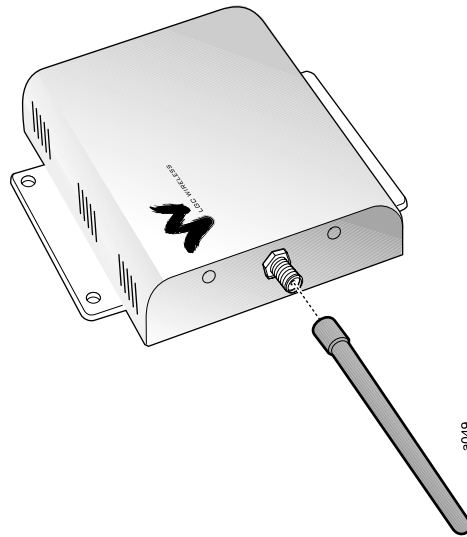

CAUTION: When connecting to the SMA female connector on the RAU and passive antenna, **DO NOT** over-tighten the connector. Firmly hand-tightening the connector is adequate.

NOTE: If an RAU is installed but an antenna is not connected, the SMA port must be terminated with a 50 ohm terminator (LGC part number 4100).

✓ Connecting the UTP/STP Cable

Connecting UTP/STP to single band RAU:

Before connecting the UTP/STP cables, confirm that they meet TIA/EIA 568-A specifications (refer to Appendix B).

Connect the UTP/STP cable coming from the Expansion Hub to the RJ-45 female jack on the RAU, as shown in the following figure.

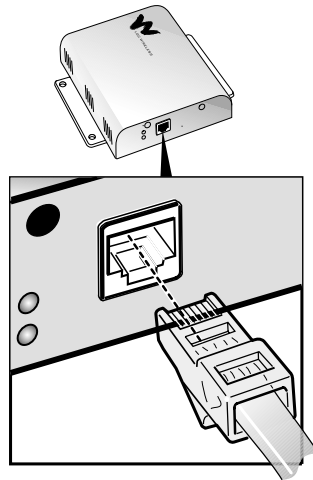

Connecting UTP/STP cable to dual band RAU:

For the 900/1800 dual band RAU, connect the 900 MHz Expansion Hub cable to the top RJ-45 jack and the 1800 MHz cable to the bottom RJ-45 jack.

For the 1800/1800 dual band RAU, connect the top (upper) 1800 MHz Expansion Hub cable to the RAU's top RJ-45 jack, and connect the bottom (lower) 1800 MHz Expansion Hub cable to the RAU's bottom RJ-45 jack.

The RJ-45 jacks on a dual band RAU are shown in the following figure.

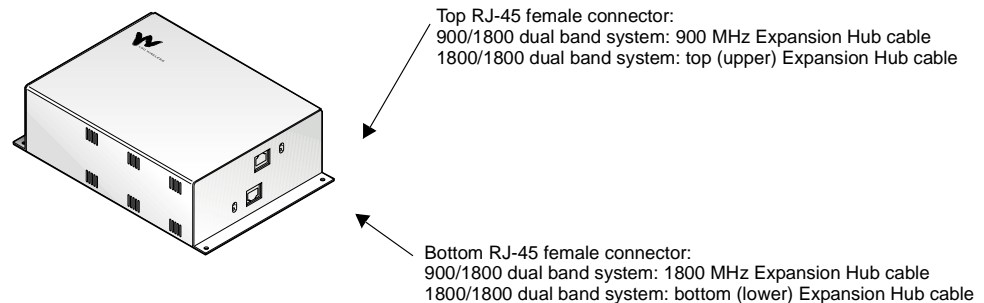

✓ **Check the RAU LEDs**

The green **POWER** LED should be on and the red **SYNC** LED should be off.

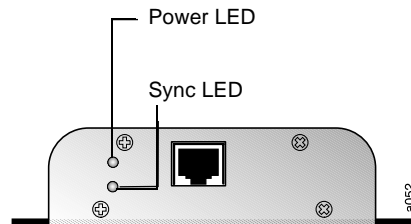

The green **POWER** LED should be lit to indicate that the RAU is receiving power from the Expansion Hub assigned to it.

The green **POWER** LED should be off if the Expansion Hub is not yet connected.

NOTE: Refer to Section 10 for troubleshooting LEDs.

✓ **Check the Expansion Hub MMF Port LEDs**

Re-check the Expansion Hub LEDs to verify that the RAUs are operating properly.

The Expansion Hub fiber port **LINK STATUS** and **SYNC** LEDs should be green if the RAUs are connected on the other end of the UTP/STP cable.

9.4.4 Installing Remote Access Units in a Neutral Host System

When installing both iDEN and cellular systems in parallel, either as dual-band or neutral host systems, special provision must be taken to assure that the individual RAUs do not interfere with each other.

It is recommended that the 800 MHz cellular and iDEN RAU's antennas be separated by 6 to 8 meters (20 to 26 feet), to assure that the iDEN downlink signals do not interfere with the cellular uplink signals.

Maintenance, Troubleshooting, and Technical Assistance

There are no user-serviceable parts in any of the LGCell components. Faulty or failed components are fully replaceable through LGC Wireless.

Address	2540 Junction Avenue San Jose, California 95134-1902 USA
Phone	1-408-952-2400
Fax	1-408-952-2410
Help Hot Line	1-800-530-9960 (U.S. only) +1-408-952-2400 (International) +44(0) 1223 597812 (Europe)
Web Address	http://www.lgcwireless.com
e-mail	service@lgcwireless.com

10.1 Maintenance

No periodic maintenance of the LGCell equipment is required.

10.2 Troubleshooting

NOTE: LGCell has no user-serviceable parts. Faulty or failed units are fully replaceable through LGC Wireless.

Sources of potential problems include:

- Malfunction of one or more LGCell components
 - Faulty cabling/connector
 - Antenna, base station, or repeater problem
 - External RF interface
-

NOTE: Faulty cabling is the cause of a vast majority of problems. All Cat-5 cable should be tested to TIA/EIA 568-A specifications.

The diagnostic procedures are based on diagnostic information in Table 10-2 on page 10-5. The table lists all LEDs and indicates what to do under certain circumstances. There is a blank table at the end of this section that you can copy and use to record the LEDs while you troubleshoot an LGCell system.

If you cannot determine the cause of a problem after following the recommended procedures, call LGC Wireless customer help hot line:

1-800-530-9960 (U.S. only)
+1-408-952-2400 (International)
+44(0) 1223 597812 (Europe)

10.2.1 Troubleshooting Guidelines

The following table contains troubleshooting information that the diagnostic LEDs do not cover. Please check the table for a possible cause of a problem. Simple checks or minor adjustments might eliminate the problem and restore proper operation.

Problem/Symptom	Check
No downlink signal output when all diagnostic LEDs are green	<p>Make sure that there is a reasonable amount of power at the input of the Main Hub. Use a power meter to measure the output power from the coaxial cable that feeds the Main Hub.</p> <p>The LGCell is intended for a different frequency band. Verify that your system corresponds to the desired frequency (for example, 800 MHz, 1800 MHz, or 1900 MHz).</p> <p>Check the part number of each unit to be sure you have the proper band (e.g., DAS19M-4A-AD is the part number for a Main Hub set up for 1900 MHz A and D bands).</p>
The system gain is lower than specification	<p>The optical fiber connector may be dirty. Clean the ST optical connector, using the manufacturer's recommended cleaning procedure.</p> <p>There are two types of multimode fiber (MMF), 62.5µm/125µm and 50µm/125µm. Make sure the vertical run of MMF is the 62.5µm/125µm type of fiber.</p> <p>Check the length of MMF and UTP/STP cabling.</p>
Remote Access Unit (RAU) power LED (green LED) stays off after you plug in the twisted pair cable	<p>The Expansion Hub provides power to the RAU. Make sure the Expansion Hub is on.</p> <p>Make sure that the twisted-pair (TP) cable wiring conforms to the TIA/EIA 568-A standard. (For information about the standard, refer to Appendix B, "TIA/EIA 568-A Cabling Standard".) Use a standard local area network (LAN) cable tester to perform this test. Make sure the Cat-5 is not plugged into the Expansion Hub when doing this test. Possible errors are incorrect wiring and/or cable length.</p>
The LGCell performance is intermittent when you use it for the CDMA application	<p>The uplink and downlink gains are not balanced. A CDMA system performs active power control between the base station and the mobile unit. It is important to maintain a balanced link from the base station ports to the RAU ports (equal uplink and downlink gain) to optimize the performance of the LGCell.</p>
Possible MMF port problem on a Main Hub	<p>To isolate possible port problems on a Main Hub try moving the faulty fiber pair to another port on the hub or to another Main Hub.</p> <p>When you move an active fiber pair, the Main Hub remembers that there was fiber on that port and issues an alarm. You must clear the latched alarm (port disconnect memory feature) by cycling Main Hub power.</p>
Possible RJ-45 port problem on an Expansion Hub	<p>Move the Cat-5 to a spare port or swap the Cat-5 to try and isolate the problem.</p> <p>The Expansion Hub also has port disconnect memory to track which ports have been connected. So when a Cat-5 is disconnected and moved to a new port, an alarm will be issued. You must cycle power to the Expansion Hub to clear the memory and the latched alarm.</p> <p>If the Expansion Hub is suspect, try and remove all RAUs to eliminate any possible RAU failure and then begin to put RAUs back in. Remember to cycle power whenever a RAU is removed.</p>
Possible RAU problem	<p>When working RAU problems, an RAU whose functionality has been confirmed can be used with about 15 m (50 ft) of Cat-5 to quickly verify ports on an Expansion Hub. Simply connect the RAU to one end of the cable and plug the other end into the Expansion Hub ports to verify proper operation.</p>
Troubleshoot downlink problem on an active system	<p>Downlink problems can be troubleshot on an active system by injecting a low-level signal at the Main Hub using the unused port (either the duplex bidirectional port or the simplex downlink port). Then you can go out to the RAU and perform some measurements without disrupting normal service.</p>

10.2.2 Troubleshooting Using the LED Indicators

10.2.2.1 LED Indicator Description

The LGCell Main Hub, Expansion Hubs, and RAUs have front panel LEDs which provide diagnostic information and operational status of each unit. Together they provide an efficient diagnostic display system, which help technicians find the fault if there is a malfunction. The LED indicators for each unit are described in the following table.

Table 10-1 LGCell Equipment LED Indicators

MAIN HUB	MMF Port Indicators		Color	Indicates
	LINK STATUS	Green		Good connection to the Expansion Hub that is connected to the port.
		Red		Connection problem with the Expansion Hub that is connected to the port.
	SYNC	Green		Expansion Hub connected to the port is operating properly.
		Red		An alarm with the Expansion Hub that is connected to the port.
	Unit Functionality Indicators		Color	Indicates
	SYNC	Green		Main Hub is correctly producing the synchronization signal.
Off			Main Hub is not correctly producing the synchronization signal.	
POWER	Green		Main Hub has power.	
EXPANSION HUB	UTP/STP Port Indicators/Color			
	LINK STATUS	SYNC		Indicates
	Green	Green		RAU is connected and functioning properly.
	Green	Red		RAU is connected but malfunctioning.
	Red	Green		RAU has been disconnected or the cable is cut.
	Red	Red		No RAU is connected.
	Unit Functionality Indicators		Color	Indicates
	SYNC	Green		Expansion Hub is receiving the synchronization signal from the Main Hub.
		Off		A fault with the MMF downlink or the unit is faulty.
	POWER	Green		Expansion Hub has power.
RAU	Unit Functionality Indicators		Color	Indicates
	POWER	Green		RAU is receiving power from the Expansion Hub.
	SYNC	Red		RAU lost sync and has shut down RF power.
		Off		No fault.

10.2.2.2 Diagnostic Procedures

Use the following table when diagnosing system problems. For troubleshooting, you can copy the blank table on page 10-8 and use it to record the LED colors on the Main Hub, the particular Expansion Hub indicating a fault, and the RAUs connected to it. This is necessary because the Main Hub, Expansion Hubs, and RAUs typically are geographically distributed.

To determine where the fault might be:

1. Go to the Main Hub and record the LEDs. The Main Hub indicates which Expansion Hub may be faulty by lighting one of its port LEDs red.
2. Go to the Expansion Hub attached to the port that has a red LED.
3. Record that Expansion Hub's LEDs. The Expansion Hub indicates which RAU(s) may be faulty by lighting its antenna LED red.
4. Go to the RAU(s) connected to the Expansion Hub port that is indicating a fault. Record the error.
5. Compare your filled in table to the Diagnostic Table below and begin troubleshooting according to the notes indicated for your situation.

Table 10-2 LED Diagnostics

Visual Alarm LEDs										Remote Alarm Contacts		See Note
Main Hub				Expansion Hub				RAU		DB-9 Connector		
Port		Functionality		Port		Functionality		Power	Sync	Major Alarm Contact	Error Latch Contact	
Link Status	Sync	Sync	Power	Link Status	Sync	Sync	Power					
Green	Green	Green	Green	Green	Green	Green	Green	Green	Green	Short	Short	1
Red	Red	Green	Green	Off	Off	Off	Off	Off	Off	Open	Open	2
Green	Red	Green	Green	Green	Red	Green	Green	Off	Off	Open	Open	3
Green	Red	Green	Green	Red	Red	Green	Green	Off	Off	Open	Open	4
Green	Red	Green	Green	Green	Red	Green	Green	Green	Red	Open	Open	5
Green	Red	Green	Green	Green	Red	Off	Green	Green	Red	Open	Open	6
Red	Red	Green	Green	Green	Red	Red	Green	Green	Red	Open	Open	7
Off	Off	Off	Off	Green	Red	Off	Green	Green	Red	Open	Open	8
Green	Red	Red	Green	Green	Red	Red	Green	Green	Red	Open	Open	9
Red	Red	Green	Green	Green	Green	Green	Green	Green	Off	Open	Open	10
Green	Red	Green	Green	Red	Red	Green	Green	Off	Off	Open	Open	11
Green	Red	Green	Green	Green	Green	Green	Green	Green	Off	Open	Open	12
Green	Red	Green	Green	Red	Green	Green	Green	Off	Off	Open	Open	13

Major and Error Latch contacts indicate an alarm when the contacts go from a short to open state.

Notes:

1. System is functioning properly.
2. The Expansion Hub is off.
Make sure the power cord is connected to a live AC power jack and that the Expansion Hub power switch is in the on (1) position.
3. Power is being delivered to the RAU but it is not turning on.
 - a. Check that the UTP/STP cable has been properly crimped and passes a standard TIA/EIA 568-A Cat-5 compliance test.
 - b. If the cable is not the problem, replace the RAU.
4. Power is not being delivered to the RAU.
 - Move the UTP cable to a different RJ-45 connector on the Expansion Hub to see if the same problem occurs.
 - If the LEDs on the new port are both green, there is a problem with the Expansion Hub.
 - If the problem persists, there is a problem with either the RAU or the UTP/STP cable.
 - Check that the UTP/STP cable has been properly crimped and passes a standard TIA/EIA 568-A Cat-5 compliance test.
 - If the cable passes the Cat-5 test, replace the RAU.
5. RAU has lost synchronization.
 - Make sure that the UTP/STP passes a standard TIA/EIA 568-A Cat-5 test.
 - If the cable passes the Cat-5 test, replace the RAU.
6. The Expansion Hub is not properly receiving the synchronization signal from the Main Hub.
 - a. The MMF cable connection might not be good or if the system was working, the MMF downlink cable is pulled out or cut. Switch MMF cables.
 - b. If the problem persists, move the MMF cable to a different Main Hub port on a different Expansion Hub. If this solves the problem, the Main Hub port on the first Expansion Hub is malfunctioning.
 - c. If the problem persists, there is an Expansion Hub problem.
 - If moving MMF cables to a different Expansion Hub is not practical, switch the uplink and downlink pairs. (A connection error may have been made when connecting the Main Hub **UP** port to the Expansion Hub **UP** port, and similarly for the **DOWN** ports.)
 - If the Expansion Hub unit **SYNC** LED turns green, one of the MMF cables was bad or the connection between the Main Hub and Expansion Hub was done incorrectly. If both are bad, this test will not help. Switch to a different Main Hub port.

7. The Expansion Hub is not properly receiving the synchronization signal from the Main Hub.
Too much loss on downlink MMF. Might be due to MMF pairs not attached to the proper connector.
 - a. Check that the “**down**” cable end is in the **DOWN** port connector on both the Main Hub and on the Expansion Hub. Same for the “**up**” cable end and connectors for the **UP** port.
 - b. If the problem persists, check the integrity of the MMF cable using an Optical Time Domain Reflectometer. If the fiber is faulty, replace it.
 - c. If the MMF cable is OK, try using a different Main Hub port.
 - d. If the problem persists, replace the Main Hub.
 - e. If the problem persists, replace the Expansion Hub.
8. The Main Hub is off.
 - Make sure the power cord is connected to a live AC power jack and that the Main Hub power switch is in the on (1) position.
9. Main Hub is not properly generating the synchronization signal.
 - Turn off the Main Hub and then turn it back on. If the unit functionality **SYNC** LED stays off, the Main Hub requires replacement.
10. The Expansion Hub is not properly sending the synchronization signal to the Main Hub.
 - The MMF cable connection might not be good, or if the system was working, the MMF uplink cable is pulled out or cut.
11. The RAU is off.
 - Check that the UTP/STP cable is operating properly.
 - Check that the UTP/STP cable has been properly crimped and passes a standard TIA/EIA 568-A Cat-5 compliance test.
 - If the system was working, the UTP/STP cable is pulled out or cut.
12. There is excessive optical loss in the uplink direction between the Expansion Hub and the Main Hub.
 - Verify that the optical loss in the uplink fiber does not exceed 3 dB optical.
 - Check the fiber ports for debris and clean if necessary.
 - The Main Hub MMF port may be faulty.
 - Move the fiber to another port.
 - The Expansion Hub may be faulty.
13. A Cat-5 cable has been disconnected and moved to a new port. The Expansion Hub’s port disconnect memory has issued an alarm.
 - You must cycle power to the Expansion Hub to clear the memory and the latched alarm.

10.3 Technical Assistance

Call our help hot line for technical assistance:

1-800-530-9960 (U.S. only)
+1-408-952-2400 (International)
+44(0) 1223 597812 (Europe)

Leave your name and phone number and an LGC Wireless customer service representative will return your call within an hour. Be prepared to provide the following information when you receive the return call:

- Company name
- End user name
- Type of system, serial number, frequency
- Approximate time in service (warranty), sales order number
- Description of problem
- LED status

Cables and Connectors

This section provides information about cables, connectors, and accessories that an LGCell application might require.

- Appendix A.1 Coaxial Cable A-2
- Appendix A.2 Multimode Fiber Cable A-2
- Appendix A.3 Category 5 UTP/STP Cable A-3

These cables are not provided with the LGCell equipment and must be on site or installed at the site prior to the LGCell installation. LGC Wireless can provide these components, or you can order them through a cable vendor or installer.

A.1 Coaxial Cable

For Duplex RF Connections

- Connects a Main Hub to a repeater or duplex base station
- Provides bidirectional downlink and uplink transmission with one cable for duplex RF connections

For Simplex RF Connections

- Connects a Main Hub to a repeater or simplex base station
- Provides unidirectional downlink and uplink signals on separate cables for simplex RF connections

A.2 Multimode Fiber Cable

- Connects Main Hub to Expansion Hub(s)
- Transmits (downlink) and receives (uplink) cellular and PCS signals
- Accommodates distances up to 1 km (3300 ft)
- Use industry-standard 62.5 μ m/125 μ m fiber

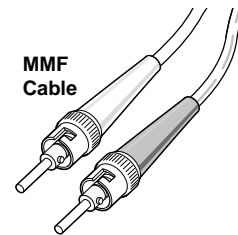

A.3 Category 5 UTP/STP Cable

- Connects the Expansion Hub to the RAU(s)
- Transmits (downlink) and receives (uplink) cellular and PCS signals
- Delivers electrical power to RAU(s)
- Accommodates distances up to 50 meters (165 ft)
- Cat-5 STP is recommended when configuring multiple systems

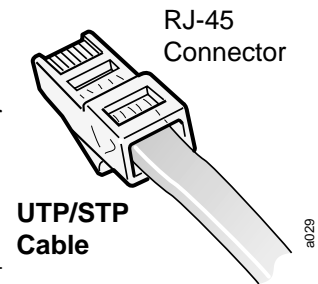

LGC Wireless recommends plenum-rated Cat-5 UTP/STP cable and connectors

NOTE: Only Cat-5 shielded twisted pair (STP) cable should be used for neutral host systems.

NOTE: UTP/STP cable length is 10 meters (33 ft) absolute minimum, 20 meters (66 ft) recommended minimum, and 50 meters (165 ft) maximum. For cables longer than 50 meters (165 ft), system specifications are slightly degraded. See Section 7.3.2, “System Gain (Loss) Relative to UTP/STP Cable Length,” on page 7-30.

UTP Termination

All UTP cable shall be terminated according to the TIA/EIA 568-A standard. The following diagram shows the top view of the wiring map for Category 5 UTP cable and how the four pairs should be terminated.

Figure A-1 Wiring Map for Cat-5 UTP Cable

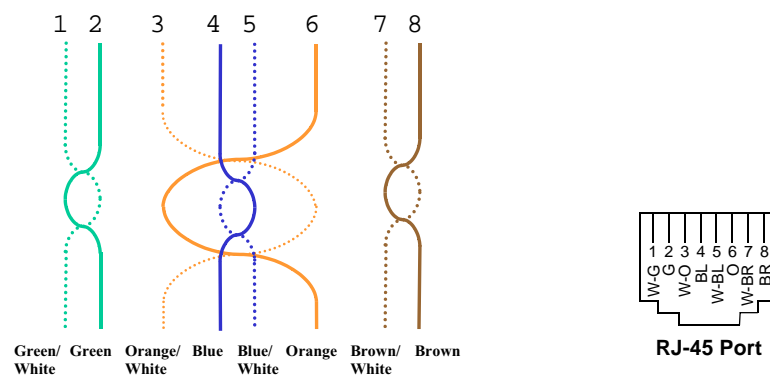

NOTE: Be sure to test cable termination before installing the cable.

TIA/EIA 568-A Cabling Standard

Following is a summary of the TIA/EIA 568-A commercial building telecommunications cabling standard.

The TIA/EIA 568-A commercial building cabling standard addresses the need for a common criterion covering cabling in commercial buildings. The standard was drafted to ensure support for a wide variety of applications, devices, and vendor products.

The TIA/EIA 568-A standard assures a flexible cabling scheme which permits the planning and installation of communications cable without prior knowledge of the user's needs. This is especially valuable for new building construction and renovation where it is less costly and less disruptive to install a universal cabling system prior to occupancy.

The need for a building cabling standard was recognized in the early 1980s. It resulted from the changes brought on by new technologies. The purpose of the original drafting committee was to provide a non-proprietary cabling system for both new and existing facilities.

In 1985, the Computer Communications Industry Association approached the Electronic Industry Association (EIA) in regard to the market's confusion over cabling systems. The EIA and later its offspring, the Telecommunications Industry Association (TIA), addressed this via technical working groups comprised of industry participants. The resulting standard 568 addressed performance and safety issues related to technology and utilized many recognized and proven standards.

The TIA/EIA 568-A standard defines the categories of UTP cabling, the categories of connecting hardware, patch cables, and provides guidelines on cabling practices.

The TIA/EIA 568-A standard describes six sub-systems within a facility telecommunications cabling system summarized below. (This is intended as a summary only and is meant to provide a better comprehension of the standard. The complete TIA/EIA 568-A standard is available for purchase. Call Global Engineering Documents at 1-800-854-7179.)

B.1 Horizontal Wiring

The horizontal cable is the portion of the cabling system which extends from the work area outlet to the telecommunications closet. The horizontal cabling is a star topology, with a maximum cabling run of 90 meters (295 feet), independent of media type.

Voice

4-pair 100 ohm UTP cable

Data

4-pair 100 ohm UTP/STP

2-pair 150 ohm STP

62.5 μ m/125 μ m fiber optic cable

The horizontal cable amounts to the greatest quantity of individual cables in the building. Although the TIA/EIA 568-A standard helps limit cabling options, consideration should be given to media type in order to support possible future needs. The cable selected should accommodate more than one network planning period.

B.2 Backbone Wiring

The backbone cabling provides the interconnection between the telecommunications closets and the equipment rooms and entrance facilities. The backbone cabling is also a star topology with the maximum cable length being media and application-dependent.

The backbone cable typically is second to horizontal cables in terms of the amount of cable deployed. The cable selected should accommodate a minimum of one to several network planning periods.

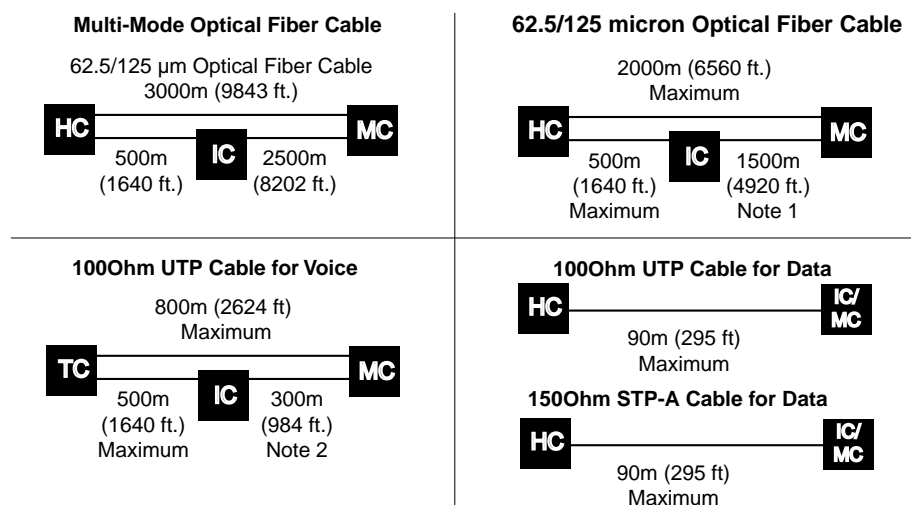

HC Horizontal Cross-Connect
MC Main Cross-Connect
IC Intermediate Cross-Connect

Notes:

1. When the HC-to-IC distance is less than maximum, the IC-to-MC distance for optical fiber can be increased accordingly but the total distance from the HC to the MC shall not exceed the maximum of 2000 m (6600 ft).
2. When the HC-to-IC distance is less than maximum, the IC-to-MC distance for UTP cable can be increased accordingly but the total distance from the HC to the MC shall not exceed the maximum of 800 m (2640 ft). For voice applications only.

B.3 Work Area

The work area interconnects the horizontal cabling at the wall outlet to the desktop devices. The maximum allowable distance for patch cables is 3 meters (9.8 feet), based on the cable being of the same type as the horizontal cable.

B.4 Telecommunications Closet

The telecommunications closet is the area in a building dedicated to telecommunication equipment. The functions which take place in the closet include the interconnection point between horizontal and backbone cabling systems, the interconnection of two or more backbone cabling systems, and/or the interconnection of the entrance facility to the overall telecommunications cabling system.

B.5 Equipment Room

The equipment room is the area in a building where telecommunications equipment is located. Parts of or all of the telecommunications cabling system terminate here.

B.6 Entrance Facilities

The entrance facility is where outside telecommunications service enters the building, and interconnects with the building's internal telecommunications systems. In a campus or multi-building environment, the entrance facility may also contain the building's backbone interconnects.

B.7 Unshielded Twisted Pair Cable Termination

All UTP (Unshielded Twisted Pair) shall be terminated according to the TIA/EIA 568-A standard.

B.8 DC Power

- DC power is supplied from the Expansion Hub to the RAUs via the Cat-5 twisted pair cable. Power is supplied on one pair (1,2) of the cable.
- The maximum voltage on the cable is 12V, which conforms with UL requirement of a maximum voltage of 60Vdc.
- Clause 14.3.1.1 of IEEE 802.3 requires Ethernet equipment to have an isolation of 2250Vdc. This means that accidentally plugging a Cat-5 twisted pair cable from an Expansion Hub into an 803.2-compliant terminal will not cause any damage.
- Clause 14.3.2.1 of IEEE 802.3 specifies that a maximum peak differential voltage of 2.8V on the twisted pair cable. With a cable impedance of 100 Ohms, this corresponds to a maximum peak power of 16 dBm. The LGCell drive level is substantially below this.

Compliance Information

All LGCell systems comply with Optical Fiber Safety Standard IEC/EN60825-2. The LGCell distributed antenna system uses light emitting diodes (LEDs) and is rated as a Class 1 optical hazard system. It has an absolute maximum output power of -11.5 dBm at 1310 nanometers (nm). There are no restrictions on the location or use of an LGCell system. No special precautions are required if standard work practices are followed. Additional information on the safe use of optical fiber communications systems is at the end of this appendix.

C.1 LGCell System Approval Status

Appendix C.1.1 through C.1.7 provide LGC Wireless' LGCell system approval status for various countries around the world. Some European countries require National Type Approval to their national standards (such as Germany).

C.1.1 800 MHz AMPS, TDMA, and CDMA

Telecom: FCC ID: NOO-DAS8-4-W

Hong Kong: Approval number: RF200110, based on the above FCC approval

EMC: FCC Class A, Part 15, Subpart B

Safety: UL 1950 3rd edition and the cUL mark for Canada

NEBS: This is a customer driven conformance certification and typically desired of equipment that is intended to be installed in a Central Office environment. LGC products are intended as Customer Premise Equipment and it is not anticipated that they will be installed in a Central Office environment, therefore NEBS conformance certification has not been pursued at this time.

C.1.2 800 MHz iDEN

Telecom: FCC ID: NOO-DAS8M-4IDEN-W

EMC: FCC Class A, Part 15, Subpart B

Safety: UL 1950 3rd edition and the cUL mark for Canada

NEBS: This is a customer driven conformance certification and typically desired of equipment that is intended to be installed in a Central Office environment. LGC products are intended as Customer Premise Equipment and it is not anticipated that they will be installed in a Central Office environment, therefore NEBS conformance certification has not been pursued at this time.

C.1.3 900 MHz EGSM/GSM

Telecom: Germany: Approval Number A200394M (BAPT 222 ZV 15/ETS 300 609-4)

UK: Approval Number BPS091 ETS 300 609-4 March 1999

Hong Kong: Approval Number RF 200066; approval based on the above UK approval

China: Approval Number (CMIID): 2000CJ0457

Singapore: Approval Number PRNEQ-0417-2000, Issued to “Roots Communications Pte. Ltd.”

EMC: ETS 300 342-3, October 1999

Safety: UL 1950 3rd edition and power supplies, Astec International Ltd., Model LPS43, Universal Micro Electronics Co. Ltd., Model UPO651S-02, and International Power Sources, Inc., Model UPO651S-02 all have CB scheme certifications

C.1.4 1800 MHz GSM

Telecom: ETS 300 609-4, October 1998

Hong Kong: Approval Number RF 200111, approval based on European Approval ETS 300 609-4

China: Approval Number 2000CJ0525

Singapore: Approval Number PRNEQ-0418-2000, Issued to “Roots Communications Pte. Ltd.”

EMC: EN 300 339, June 1998

Safety: Power Supplies, Astec International Ltd., Model LPS 43, Universal Micro Electronics Co. Ltd., Model UPO651S-02, and International Power Sources, Inc., Model UPO651S-02 all have CB scheme certifications.

Markings: The UK approval number and the CE mark are required.

C.1.5 1900 MHz TDMA, CDMA, and GSM

Telecom: FCC: NOO-DAS19-4-X (FCC Part 24E) Distributed Antenna System (Repeater)

Canada: 3077331163A for the “PCS 1900” (RSS-133, Issue 1)

EMC: FCC: Class A, Part 15, Subpart B
Industry Canada: Same as FCC

Safety: UL 1950, 3rd Edition and the cUL mark for the Canadian equivalent.

NEBS: This is a customer driven conformance certification and typically desired of equipment that is intended to be installed in a Central Office environment. LGC products are intended as Customer Premise Equipment and it is not anticipated that they will be installed in a Central Office environment, therefore NEBS conformance certification has not been pursued at this time.

Markings: The FCC approval number and the FCC logo are required. The word Canada followed by the Canadian approval number is required. The UL mark is required.

C.1.6 FCC Regulatory Notice

This device complies with Part 15 of the FCC Rules. Operation is subject to the following two conditions:

- This device may not cause harmful interference.
- This device must accept any interference received, including interference that may cause undesired operation.

C.1.7 Industry Canada Regulatory Notice

This Class B (or Class A, if so indicated on the registration label) digital apparatus meets the requirements of the Canadian Interference-Causing Equipment Regulations.

Cet appareil numérique de la Classe B (ou Classe A, si ainsi indique sur l'étiquette d'enregistrement) respecte toutes les exigences du Règlement sur le Matériel Brouilleur du Canada.

C.2 Declaration of Conformity to Type

DECLARATION OF CONFORMITY

We, LGC Wireless, of 2540 Junction Ave., San Jose, California, 95134-1902, declare under our sole responsibility that the product:

LGCell, EGSM/GSM 900 Repeater, Model DAS9M-4E-W, to which this declaration relates, is in conformity with the following standards and/or other normative documents.

ETS 300 342-3, October 1999

ETS 300 609-4, March 1999

BAPT 222 ZV 15

We hereby declare that all essential radio test suites have been carried out and that the above named product is in conformity to all the essential requirements of Directive 1999/5/EC.

The conformity assessment procedure referred to in Article 10 and detailed in Annex IV of Directive 1999/5/EC has been followed with the involvement of the following Notified Body:

BABT, Claremont House, 34 Molesey Road, Walton-on-Thames, KT12 4RQ, UK

Identification Mark: **168**

The technical documentation relevant to the above equipment will be held at:

LGC Wireless, UK
G10 Regus House, Cambourne Business
Park, Cambourne, Cambridge
United Kingdom, CB3 6DP

John Dorsey
RF Approvals Engineer

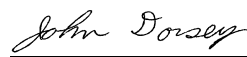

Signature

March 14, 2001

Date

Declaration of Conformity to Type

I hereby declare that the product:

LGCell GSM 900 Repeater, Type DAS9M-2-W

is in conformity with the type as described in EC Type-examination certificate:

Certificate of EC type Examination of Electromagnetic Compatibility No. 14082

and satisfies all the technical regulations applicable to the product within the scope of Council Directives 91/263/EEC and 93/97/EEC:

EN 300 339 June 98 (Certificate of EC Type Examination No. 14082 issued by Radiocommunications Agency, UK)

ETS 300 609-4 October 98 (Certificate of Type Approval No. 14028 issued by Radiocommunications Agency, UK)

BAPT 222 ZV 15 (Issued German type approval mark No. TPS A2000296L)

MANUFACTURER:

LGC Wireless Inc.
2540 Junction Avenue
San Jose
California, 95134-1902
USA

Point of contact:

Mr. Paul Allan

Tel: +1 408 952 2486

Fax: +1 408 952 2686



PAUL ALLAN

California, USA 8/26/99

DECLARATION OF CONFORMITY

We, LGC Wireless, of 2540 Junction Ave., San Jose, California, 95134-1902, declare under our sole responsibility that the product:

LGCell, DCS 1800 Repeater, Model DAS18M-2, to which this declaration relates, is in conformity with the following standards and/or other normative documents.

EN 300 339, June 1998

ETS 300 609-4, October 1998

BAPT 222 ZV 15

We hereby declare that all essential radio test suites have been carried out and that the above named product is in conformity to all the essential requirements of Directive 1999/5/EC.

The conformity assessment procedure referred to in Article 10 and detailed in Annex IV of Directive 1999/5/EC has been followed with the involvement of the following Notified Body:

BABT, Claremont House, 34 Molesey Road, Walton-on-Thames, KT12 4RQ, UK

Identification Mark: **168**

The technical documentation relevant to the above equipment will be held at:

LGC Wireless, UK
G10 Regus House, Cambourne Business
Park, Cambourne, Cambridge
United Kingdom, CB3 6DP

John Dorsey
RF Approvals Engineer

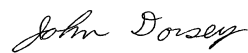

Signature

March 14, 2001

Date

C.3 IEC/EN 60825-2: Safe Use of Optical Fiber Communication Systems

Part 2 of IEC 60825 provides requirements and specific guidance for the safe use of optical fiber communications where optical power may be accessible at some distance from the optical source. In this part of IEC 825, light emitting diodes (LEDs) are included whenever the word “laser” is used.

C.3.1 Description of LGCell System

The LGCell is a distributed antenna system. It consists of three main components. A Main Hub, which is connected by multimode fiber optic cables to one or more Expansion Hubs. Each Expansion Hub is connected by UTP Cat-5 cable to up to four Remote Access Units. Because LEDs are used to send a signal over the fiber optic cable, the LGCell is covered under the IEC 60825 specification.

C.3.2 Requirements under IEC 60825

Under IEC 60825, LGC Wireless is required to determine the Class of operation of the LGCell system, the hazard level of the LGCell system and any special instructions that must be included in an operators manual as well as any warning labels that may be required on the LGCell system.

The LGCell is covered only under these definitions of section 3 of 60825:

- **3.2 Enclosed System:** A system in which, during normal operation, the optical radiation is totally enclosed, by light-proof cabinets, components, total internal reflection or optical fiber cables and connectors.
- **3.3 End User:** The person or organization using the optical fiber communication in the manner the system was designed to be used. The user cannot necessarily control the power generated and transmitted within the system.
- **3.4 Hazard Level 1:** A hazard level 1 is allocated to any part within an optical fiber communication system at which, under reasonably foreseeable circumstances, human access to laser radiation in excess of the accessible emission limits (AEL) of class 1 for the applicable wavelengths and emission duration will not occur.
- **3.10 Light Emitting Diode (LED):** Any semiconductor device which can be made to produce electromagnetic optical radiation in the wavelength range from 180nm to 1mm. (The optical radiation is produced by the process of spontaneous emission, although some stimulated emission may be present.)
- **3.13 Location with Controlled Access:** A location where access to the protective housing (enclosure) is controlled and is accessible only to authorized persons who

have received adequate training in laser safety and servicing of the system involved. Examples include optical cable ducts and switching centers.

- **3.14 Location with Restricted Access:** A location where access to the protective housing is restricted and not open to the public. Examples include industrial and commercial premises, PBX rooms, computer system rooms, and optical test sets. Distributed fiber networks may pass through unrestricted public areas, restricted areas within premises, as well as controlled areas or they may be deployed entirely within restricted business premises.
- **3.18 Optical Fiber Communication System:** An engineered assembly for the generation, transference, and reception of optical radiation arising from lasers in which the transference is by means of optical fiber for communication purposes.
- **3.19 Reasonable Foreseeable Event:** An event, the occurrence of which under given circumstances can be predicted fairly accurately, and the occurrence of which is a possibility. Examples of reasonably foreseeable events might include the following: fiber cable break, optical connector disconnection, operator error or inattention to safe working practices. Reckless use or use for completely inappropriate purposes is not to be considered as a reasonably foreseeable event.

C.3.3 Installation Notes

The LGCell is covered under these parts of section 5 of 60825:

- **5.2.1.3 Test Equipment:** During installation or testing of an optical fiber cable or system, only test equipment of laser Class 1 should be used.
- **5.2.1.5 Installation Rules:** Each person engaged in the installation or service of an optical fiber cable communication system should observe all rules, procedures, and practices established for the safe operation of optical fiber communication systems.

C.3.4 Evaluation of LGC System

The LGCell is covered under Annex A of 60825.

The LGCell system is a self-contained product that contains an optical fiber communication system that would be safe under normal operating conditions because the optical radiation is totally enclosed and contained under intended operation. However, because of the extended nature of the system, the optical power may be accessible a kilometer from the optical source. The LGCell system contains LEDs, which are the source of radiation covered under IEC 825. Usually a whole fiber optical communication system would not be classified under IEC 825-2 in the same way required under IEC 825-1. This is because, under intended operation, the optical power is totally enclosed, and it could be argued that an interpretation of IEC 825-1 would give a class 1 to all systems, which may not accurately reflect the hazard potential of some systems. If the emitter can be operated separately, it should be classified

according to IEC 825-1. However, the power output level of the LGCell system is so low that it always falls into the class 1 hazard level even under 100% modulation conditions. The absolute maximum allowed at 1300nm is +9.5 dBm. The absolute maximum accessible output of the LGCell fiber optic system is –11.5 dBm. Therefore there is no restriction as to location of use of the LGCell system and there is no labeling requirement.

C.3.5 Suggested Work Practices

The LGCell is covered under these parts of section D7 of 60825

The following working practices are suggested for working on the LGCell system:

- **Viewing Fiber:** Do not stare with unprotected eyes at the connector ends of the fibers or the ports of the hub.
- **Test Fibers Cables:** When using test fiber optical cables, the optical power source shall be the last to be connected and the first to be disconnected.
- **Fiber ends:** Any unconnected fiber ends should be covered with an approved cap. Do not use tape.
- **Broken Fiber Cables:** Do not stare with unprotected eyes at any broken ends of the fibers. Report and have any broken fiber cables replaced.
- **Cleaning:** Use only approved methods for cleaning optical fiber connectors.
- **Modification:** Do not make any unauthorized modifications to this fiber optical system of associated equipment.
- **Live work:** Live work is permitted on the LGCell as it is a class 1 hazard.
- **Signs:** No warning signs are required.
- **Test Equipment:** Use class 1 test equipment.

C.4 Human Exposure to RF

The U.S. Federal Communications Commission (FCC) has adopted limits of human exposure to radio frequency (RF) emissions from portable or fixed RF systems that are regulated by the FCC. The exposure limits on the incident electric and magnetic fields and power densities are based on ANSI/IEEE and NCRP RF Safety Guidelines. The limits are also prescribed in terms of the mass-normalized rates of internal energy absorption by tissues (specific absorption rates or SARs) which should not exceed 0.08 W/kg as averaged over the whole body and 1.6 W/kg for any 1-g of tissue.

Similarly, the U.K. National Radiological Protection Board (NRPB) and the International Commission on Non-Ionizing Radiation Protection (ICNIRP) have both established guidelines for maximum RF exposure levels that are likely to not pose health risks. For the general public, ICNIRP recommends maximum exposure levels of 2.0 W/kg for any 10-g of tissue. This recommendation is 5 times lower than that of NRPB.

The specific absorption rate (SAR) was measured for a radiated power of 20 dBm (100 mW) which is the maximum radiated for both of the antennas. The highest SAR regions for each of the antennas for separation distances of 0, 1, 2, and 3 cm to the tissue-simulant model were determined in the first instance by using a coarser sampling with a step size of 8.0 mm over three overlapping scan areas for a total scan area of 8.0×9.6 cm. After identifying the regions of the highest SAR for each of the cases, the SAR distributions were measured with a resolution of 2 mm in order to obtain the peak 1 cm³ or 1-g SAR.

The peak 1-g SARs were measured and are shown in Table C-1. The reason for the lower SARs for the 800 MHz lower frequency antenna for each of the separation distances is the larger size of the RAU Model 850 OM3W-SM00L antenna. This helps to spread the electromagnetic fields thus resulting in lower SARs.

Table C-1 Peak 1-g SAR for RAU Models 850 and 1900

RAU Distance from a Human Head (cm)	800 MHz System Peak 1-g SAR	1900 MHz System Peak 1-g SAR
0	1.331	4.995
1	0.942	2.213
2	0.646	1.153
3	0.472	0.676

Note that for 800 MHz RAUs at all separation distances, SARs are less than 1.6 W/kg, the level suggested in the FCC, IEEE/ANSI, NCRP, and ICNIRP Guidelines. For the 1900 MHz antenna, a separation distance of 2 cm from the antenna surface to the tissue is enough to comply with the peak 1-g SAR of 1.6 W/kg suggested in the various safety guidelines.

Frequently Asked Questions

- ***What is the LGCell Distributed Antenna System?***

The LGCell Distributed Antenna System (DAS) contains multiple low-power radiating elements that are deployed around indoor facilities to improve coverage and capacity. The unique, patented architecture of the LGCell DAS provides an inexpensive solution to the wireless operator or wireless network manager for coverage/capacity upgrades and private microcell applications.

- ***What is twisted pair cable? Will it pick up spurious emissions?***

Twisted pair (TP) cable is the standard cable that you find at the back of your computer for the network hookup. TP cable is the most ubiquitous cable in any office building. Furthermore, TP cable is inexpensive and easy to install. The twisting nature of the cable creates a transmission line for efficient signal transfer and rejection of spurious emissions. The LGCell uses a state-of-the-art common-mode rejection device that reduces pickup of spurious emissions on a TP cable by a factor of 10,000.

- ***Can a single LGCell simultaneously support multiple access standards (such as 800 AMPS/TDMA)?***

Yes. The LGCell is a frequency selective product. The LGCell system is transparent to the protocol that the base station and mobile unit use. You can view the entire system with all the cables together as a frequency selective repeater with a specified gain.

- ***What is the bandwidth of the LGCell?***

LGCell passes selected frequencies to minimize amplification of unwanted signals. Refer to the data specifications for the RF bandwidth of the system.

Another interpretation of bandwidth is the amount of data that the LGCell system can transmit. The microcellular or macrocellular base station to which the LGCell is connected limits the bandwidth or capacity of the LGCell, which is independent of the wireless protocol and service. Total, composite output power and spurious emissions are the only constraints that limit the number of channels that an RAU can radiate. Furthermore, the LGCell system will not limit the data rate of the modulation transmitted through the system.

- ***Can the LGCell support multiband operation?***

The LGCell provides a wide variety of single-band products, including the U.S. 800 MHz, European GSM 900, DCS 1800, Korean PCS 1800, U.S. PCS 1900 systems, and iDEN. You can use these systems together to provide multiband services. In addition, LGC has dual band 800/1900, 900/1800, and 1800/1800 LGCell systems available.

Additionally, an LGCell neutral host configuration can simultaneously support multiple bands and protocols.

- ***Can the LGCell system share the same UTP Category 5 cable with the Ethernet network?***

No. The LGCell system can use the existing unused cabling inside the building; however, you cannot use the same cable to connect an RAU and a computer.

- ***What is the minimum power input to the Main Hub?***

Refer to link budget calculation for the minimum acceptable power required to provide the desired levels of RF coverage..

- ***What is the minimum detectable power of an RAU?***

The minimum detectable power of system with 1 RAU is -114 dBm in a 30 kHz bandwidth, -106 dBm in a 200 kHz bandwidth, and -98 dBm in a 1.25 MHz bandwidth. These figures do not take into account the processing gain of different access standards, which could decrease the minimum levels.

- ***What is the difference between connecting the LGCell to a roof-mounted antenna and to a microcellular base station?***

Connecting the LGCell to a roof-mounted antenna increases the coverage of the indoor environment. Connecting the LGCell to a microcellular base station improves both the coverage and the capacity in the building and might also provide a private wireless office application for the customer.

- ***Does each Main Hub require a separate coaxial feed to the base station?***

A typical RF input power per channel to the Main Hub is 0 dBm. This provides a lot of margin (link budget margin) for interfacing with antennas through a base station that typically has an output power of 20 dBm. Therefore, a power combiner/splitter might be installed between the Main Hub and the base station. This enables one base station to connect to multiple Main Hubs.

- ***Can I exceed the 3 dB optical loss in the fiber?***

No. Exceeding the 3 dB optical loss in the fiber will result in an unreliable link indicated by sync alarms.

- ***Is the multimode fiber step or graded index fiber?***

Graded index.

-
-
- ***Can the LGCell use 50µm/125µm multimode optical fiber?***

The LGCell is designed for use with 62.5µm/125µm fiber. Use of 50µm/125µm fiber results in higher optical losses and degraded performance.

- ***How much space does the Main Hub and Expansion Hub use in a 19 in. rack?***

Both units use 1U of rack space.

- ***Can I connect the LGCell alarms to a base station?***

Yes. Use the major alarm contacts only. The base station supplies the return ground and voltage.

Frequently Asked Questions

Glossary

Air Interface A method for formatting data and voice onto radio waves. Common air interfaces include AMPS, TDMA, CDMA, and GSM.

AIN Advanced Intelligent Network. AINs allow a wireless user to make and receive phone calls while roaming outside the user's "home" network. These networks, which rely on computers and sophisticated switching techniques, also provide many Personal Communications Service (PCS) features.

Amplitude The distance between high and low points of a waveform or signal.

AMPS Advanced Mobile Phone Service. AMPS is an analog cellular FDMA system. It was the basis of the first commercial wireless communication system in the U.S and has been used in more than 35 other countries worldwide.

Analog The original method of modulating radio signals so they can carry information which involves transmitting a continuously variable signal. Amplitude Modification (AM) and Frequency Modulation (FM) are the most common methods of analog modulation.

ANSI The American National Standards Institute. A nonprofit, privately funded membership organization founded in 1918 that reviews and approves standards developed by other organizations.

Antenna A device for transmitting and/or receiving signals.

Attenuation The decrease in power that occurs when any signal is transmitted. Attenuation is measured in decibels (dB).

Backhaul A term applied to the process of carrying wireless traffic between the MSC and the base station.

Base Station The radio transmitter/receiver that maintains communications with mobile devices within a specific area.

BSC Base Station Controller. A GSM term referring to the device in charge of managing the radio interface in a GSM system, including the allocation and release of radio channels and hand-off of active calls within the system.

- BTA** Basic Trading Area. The U.S. and its territories are divided into 493 areas, called BTAs. These BTAs are composed of a specific list of counties, based on a system originally developed by Rand McNally. The FCC grants licenses to wireless operators to provide service within these BTAs and/or MTAs. (See MTA.)
- BTS** Base Transceiver Station. A GSM term referring to the group of network devices that provide radio transmission and reception, including antennas.
- C/I** Carrier to interference ratio. The ratio of the desired signal strength to the combined interference of all mobile phones using the system. Usually, the interference of most concern is that provided by mobile phones using the same channel in the system. These are referred to as “co-channel interferers.”
- CCITT** Consultative Committee on International Telephone and Telegraph. This organization sets international communications standards. The CCITT is now known as ITU (the parent organization).
- CDMA** Code Division Multiple Access. A digital wireless access technology that uses spread-spectrum techniques. Unlike alternative systems, such as GSM, that use time-division multiplexing (TDM), CDMA does not assign a specific frequency to each user. Instead, every channel uses the full available spectrum. Individual conversations are assigned a unique code which allows the conversation to be spread out over multiple channels; transmitted to the far end; and re-assembled for the recipient using a specific code.
- CDPD** Cellular Digital Packet Data. CDPD allows data transmission over the analog wireless network. CDPD breaks data into packets and transmits these packets on idle portions of the network.
- Cell** A cell defines a specific, physical area of coverage of a portion of a wireless system. It is the basic “building block” of all modern wireless communications systems.
- Cell Site** A term which refers to the location of the transmission equipment (e.g., basestation) within the cell.
- CEPT** Conference of European Postal and Telecommunications Administrations. This organization’s mandate is to define pan-European wireless communications standards. In 1982, CEPT mandated GSM as the access protocol for public wireless communications systems across Europe.
- Channel** The path along which a communications signal is transmitted. Channels may be simplex (communication occurs in only one direction), duplex (communication occurs in both directions) or full duplex (communication occurs in both directions simultaneously).
- Circuit** A communication connection between two or more points. A circuit can transmit either voice or data.
- CO** Central Office. The main switching facility for a telecommunications system.

CTIA Cellular Telecommunications Industry Association. The CTIA is an industry association made up of most of the wireless carriers and other industry players. It was formed in 1984 to promote the cellular industry and cellular technology.

D-AMPS Digital Advanced Mobile Phone Service. See IS-54.

dB Decibel. A unit for expressing the ratio of two amounts of power. It is often used in wireless to describe the amount of power loss in a system (i.e., the ratio of transmitted power to received power).

DCS Digital Communications System. DCS is often called “upbanded GSM” since it is the GSM access scheme adopted to operate in the 1700–1800 MHz portion of the spectrum.

Digital A method of storing, processing, and transmitting information by representing information as “0s” and “1s” via electrical pulses. Digital systems have largely replaced analog systems because they can carry more data at higher speed than analog transmission systems.

Electromagnetic Spectrum Electrical wave forms in frequency ranges as low as 535 kHz (AM radio) and as high as 29 GHz (cable TV).

ESMR Enhanced Specialized Mobile Radio. Digital mobile telephone services offered to the public over channels previously used for two-way analog dispatch services. ESMR provides digital mobile radio and telephone service as well as messaging and dispatch features.

ETSI European Telecommunications Standards Institute. ETSI was established in 1988 to set standards for Europe in telecommunications, broadcasting and office information technology.

FCC Federal Communications Commission. In the United States, the FCC is responsible for the management and regulation of communication policy for all public communications services, including wireless.

FDMA Frequency Division Multiple Access. A wireless access protocol that assigns each user a specific radio channel for use. Since FDMA only supports one user (or conversation) on each channel, it does not maximize use of the spectrum and is therefore largely superseded by other access protocols (such as CDMA, TDMA, GSM, iDEN) that support multiple users on a single channel.

Frequency Hopping A wireless signal transmission technique whereby the frequency used to carry a signal is periodically changed, according to a predetermined code, to another frequency.

Fixed An ITU definition for radio communications between specified fixed points. Point-to-point high-frequency circuits and microwave links are two examples of fixed applications.

FM Frequency Modulation. A method of transmitting information in which the frequency of the carrier is modified according to a plan agreed to by the transmitter and the receiver. FM can be either analog or digital.

Forward Channel Refers to the radio channel that sends information from the base station to the mobile station. (See Reverse Channel.)

Frequency The number of times an electrical signal repeats an identical cycle in a unit of time, normally one second. One Hertz (Hz) is one cycle per second.

Frequency re-use The ability to use the same frequencies repeatedly across a cellular system. Because each cell is designed to use radio frequencies only within its boundaries, the same frequencies can be reused in other cells not far away with little potential for interference. The reuse of frequencies is what enables a cellular system to handle a huge number of calls with a limited number of channels.

Gain The increase in power that occurs when any signal is amplified, usually through an amplifier or antenna.

GHz Gigahertz. A measure of frequency equal to one billion hertz.

GSM Groupe Speciale Mobile (now translated in English as Global Standard for Mobile Communications). GSM is the digital wireless standard used throughout Europe, in much of Asia, as well as by some operators in the U.S. and South America.

Handoff The process by which the wireless system passes a wireless phone conversation from one radio frequency in one cell to another radio frequency in another as the caller moves between two cells. In most systems today, this handoff is performed so quickly that callers don't notice.

Hertz A measurement of electromagnetic energy, equivalent to one "wave" per second. Hertz is abbreviated as "Hz".

iDEN Integrated Digital Enhanced Network. A TDMA-based wireless access technology that combines two-way radio, telephone, text message, and data transmission into one network. This system was developed by Motorola. In the U.S., iDEN is used by Nextel in its network.

IEEE The Institute of Electrical and Electronics Engineers. The world's largest technical professional society with members from more than 130 countries. The IEEE works to advance the theory and practice of electrical, electronics, computer engineering and computer science.

Infrastructure A term used to encompass all of the equipment, including both hardware and software, used in a communications network.

IS-54 Interim Standard-54. A U.S. TDMA cellular standard that operates in the 800 MHz or 1900 MHz band. IS-54 was the first U.S. digital cellular standard. It was adopted by the CTIA in 1990.

IS-95 Interim Standard-95. A U.S. CDMA cellular standard that operates in the 800 MHz or 1900 MHz band. This standard was developed by Qualcomm and adopted by the CTIA in 1993.

IS-136 Interim Standard-136. A U.S. TDMA cellular standard based on IS-54 that operates in the 800 MHz or 1900 MHz band.

IS-553 Interim Standard-533. The U.S. analog cellular (AMPS) air interface standard.

ITU International Telecommunications Union. The ITU is the principal international standards organization. It is chartered by the United Nations and it establishes international regulations governing global telecommunications networks and services. Its headquarters are in Geneva, Switzerland.

LMDS Local Multipoint Distribution Services. LMDS provides line-of-sight coverage over distances up to 3–5 kilometers and operates in the 28 GHz portion of the spectrum. It can deliver high speed, high bandwidth services such as data and video applications.

Local Loop A communication channel (usually a physical phone line) between a subscriber's location and the network's Central Office.

MHz Megahertz. One million Hertz. One MHz equals one million cycles per second.

Microcell A network cell designed to serve a smaller area than larger macrocells. Microcells are smaller and lower powered than macrocells. As the subscriber base increases, operators must continue to increase the number of cells in their network to maximize channel re-use. This has led to an increasing number of microcells being deployed in wireless networks.

Microwave Electromagnetic waves with frequencies above 1 GHz. Microwave communications are used for line-of-sight, point-to-point, or point-to-multipoint communications.

MSA Metropolitan Statistical Area. The FCC has established 306 MSAs in the U.S. The MSAs represent the largest population centers in the U.S. At least two wireless operators are licensed in each MSA.

MSC Mobile Services Switching Center. A generic term for the main cellular switching center in the wireless communications network.

MSS Mobile Satellite Service. Communications transmission service provided by satellites. A single satellite can provide coverage to the entire United States.

MTA Major Trading Area. The U.S. and its territories are divided into 51 MTAs. Each MTA is composed of a specific number of BTAs. The FCC grants licenses to wireless operators to provide service within these MTAs and/or BTAs. (See BTA.)

Multiplexing The simultaneous transmission of two or more signals on the same radio (or other) transmission facility.

N-AMPS Narrowband Advanced Mobile Phone Service.

PCMCIA Personal Computer Memory Card International Association. This acronym is used to refer to credit card sized packages containing memory, I/O devices and other capabilities for use in Personal Computers, handheld computers and other devices.

PCS Personal Communications Service. A vague label applied to new-generation mobile communication technology that uses the narrow band and broadband spectrum recently allocated in the 1.9 GHz band.

PDA Personal Digital Assistant. Portable computing devices that are extremely portable and that offer a variety of wireless communication capabilities, including paging, electronic mail, stock quotations, handwriting recognition, facsimile, calendar, and other information handling capabilities.

PDC Personal Digital Cellular (formerly Japanese Digital Cellular). A TDMA-based digital cellular standard that operates in the 1500 MHz band.

Phase The particular angle of inflection of a wave at a precise moment in time. It is normally measured in terms of degrees.

PHS Personal Handyphone System. A wireless telephone standard, developed and first deployed in Japan. It is a low mobility, small-cell system.

POP Short for "population". One person equals one POP.

POTS Plain Old Telephone Service.

PSTN Public Switched Telephone Network. Refers to the international telephone system and includes both local and long distance networks.

Reverse Channel Refers to the radio channel that sends information from a mobile station to a base station. (See Forward Channel.)

RF Radio Frequency. Those frequencies in the electromagnetic spectrum that are associated with radio wave propagation.

Roaming The ability to use a wireless phone to make and receive calls in places outside one's home calling area.

RSA Rural Service Area. One of the 428 FCC-designated rural markets across the United States used as license areas for cellular licenses. (See MTAs and BTAs.)

Sector A portion of a cell. Often, different sectors within the same cell will each use a different set of frequencies to maximize spectrum utilization.

Signal to Noise Ratio The ratio of signal power to noise power at a given point in a given system.

Smart Antenna Refers to an antenna whose signal handling characteristics change as signal conditions change.

Soft Handoff Virtually undetectable by the user, soft handoff allows both the original cell and a new cell to serve a call temporarily during the handoff transition.

Spectrum The range of electromagnetic frequencies.

Spread Spectrum A method of transmitting a signal over a broad range of frequencies and then re-assembling the transmission at the far end. This technique reduces interference and increases the number of simultaneous conversations within a given radio frequency band.

T-1 A North American commercial digital transmission standard. A T-1 connection uses time division multiplexing to carry 24 digital voice or data channels over copper wire.

TDMA Time Division Multiple Access. A method of digital wireless communications that allows multiple users to access (in sequence) a single radio frequency channel without interference by allocating unique time slots to each user within each channel.

TIA Telecommunications Industry Association.

TR-45 One of six committees of the Telecommunications Industry Association. TR-45 oversees the standard making process for wireless telecommunications.

Upbanded A service or technology that has been re-engineered to operate at a higher frequency than originally designed.

Wireless Describes any radio-based system that allows transmission of voice and/or data signals through the air without a physical connection, such as a metal wire or fiber optic cable.

Wireline Wire paths that use metallic conductors to provide electrical connections between components of a system, such as a communication system.

WLANS Wireless Local Area Networks. Technology that provides wireless communications to Portable Computer users over short distances.

