



Digivance® LRCS SDR PCIx Host Card Installation Instructions

Content	Page
INTRODUCTION	2
Revision History	2
List of Changes	2
Trademark Information	2
Admonishments	2
General Safety Precautions	2
FCC/IC Compliance Statement	3
Certification: UL/CSA Recognized	3
1 DESCRIPTION	3
2 SDR CARD INSTALLATION	5
2.1 Power Down the Server	5
2.2 Extend Server from the Rack	5
2.3 Remove Access Panel	5
2.4 Remove PCI Riser Cage	6
2.5 Remove Expansion Slot Cover	6
2.6 Installing a SDR PCIx Host Card	6
2.7 Install PCI Riser Cage	6
2.8 Install Access Panel	7
2.9 Slide Server Into Rack	7
3 SDR PCIX HOST CARD CABLING	7
3.1 Optical and Electrical Connections	7
3.2 Coax Cabling	7
3.3 Optical Cabling	8
3.4 Modular Optical Transceiver Installation	11
4 POWERING UP THE SERVER	13
5 GAIN CONFIGURATION PARAMETERS	13
5.1 Gain (Attenuation)	13
5.2 Wide-band Gain (Attenuation)	13
6 OPERATION	13
6.1 Alarm LED	13
7 SPECIFICATIONS	14
8 CUSTOMER INFORMATION AND ASSISTANCE	17

INTRODUCTION

These instructions provide installation information for installing a Software Defined Radio (SDR) PCIx host card in a dedicated server.

Revision History

ISSUE	DATE	REASON FOR CHANGE
1	09/2004	Original Publication

List of Changes

PAGE	IDENTIFIER	DESCRIPTION OF CHANGE
All	—	New document

Trademark Information

ADC and Digivance are registered trademarks of ADC Telecommunications, Inc.

Admonishments

Important safety admonishments are used throughout this manual to warn of possible hazards to persons or equipment. An admonishment identifies a possible hazard and then explains what may happen if the hazard is not avoided. The admonishments — in the form of Dangers, Warnings, and Cautions — must be followed at all times. These warnings are flagged by use of the triangular alert icon (seen below), and are listed in descending order of severity of injury or damage and likelihood of occurrence.



Danger: *Danger is used to indicate the presence of a hazard that **will** cause severe personal injury, death, or substantial property damage if the hazard is not avoided.*



Warning: *Warning is used to indicate the presence of a hazard that **can** cause severe personal injury, death, or substantial property damage if the hazard is not avoided.*



Caution: *Caution is used to indicate the presence of a hazard that **will** or **can** cause minor personal injury or property damage if the hazard is not avoided.*

General Safety Precautions



Caution: *Electronic modules can be damaged by electrostatic discharge (ESD). To prevent this, take the following precautions:*

- *Wear an anti-static-discharge wrist strap while handling modules.*
- *Place modules in anti-static packing material when transporting or storing them.*



Warning: *To prevent electrical shock, never install equipment in a wet location or during a lightning storm. When installing or modifying telephone lines, disconnect lines at the network interface before working with uninsulated lines or terminals. Disconnect all power feeds before working with uninsulated lines or terminals.*



Danger: *This equipment uses a Class 1 Laser according to FDA/CDRH rules. Laser radiation can seriously damage the retina of the eye. Do not look into the ends of any optical fiber. Do not look directly into the optical transceiver of any digital unit or exposure to laser radiation may result. An optical power meter should be used to verify active fibers. A protective cap or hood **MUST** be immediately placed over any radiating transceiver or optical fiber connector to avoid the potential of dangerous amounts of radiation exposure. This practice also prevents dirt particles from entering the transceiver or connector.*

FCC/IC Compliance Statement

SDR PCIx host card has been certified to comply with the requirements for Class B computing devices per part 15 of the FCC regulations and applicable sections of Title 47 CFR Part 22.



Warning: *This equipment generates, uses, and can radiate radio frequency energy and if not installed and used in accordance with the instruction manual, may cause interference to radio communications. It has been tested and found to comply with limits for a Class B digital device pursuant to Subpart B of Part 15 of FCC Rules, which are designed to provide reasonable protection against such interference when operated in a residential environment. If interference to TV and radio reception does occur relocate or reorient the antenna of the affected radio or TV.*

This equipment does not exceed Class B limits for radio emission for digital apparatus, set out in the radio interference regulation of the authorization methods of Industry Canada.

This equipment complies with the applicable sections of RSS-131. The term “IC:” before the radio certification number only signifies that Industry Canada Technical Specifications were met.

This product conforms to all applicable standards of 21 CFR 1040.

Certification: UL/CSA Recognized

SDR PCIx host card has been tested and found to comply with the requirements of UL/CSA 60950.

1 DESCRIPTION

Software Defined Radio (SDR), refers to wireless communication in which the transmitter modulation is generated and receiver demodulation recovered by software operating on a computer. To select the desired modulation and demodulation type, configuration programs must be run by microcomputers controlling the transmitter and receiver.

The most significant asset of SDR is versatility. Wireless systems employ protocols that vary from one service to another. Even in the same type of service, for example wireless fax, the

protocol often differs from country to country. A single SDR set with an all-inclusive software repertoire can be used in any mode, anywhere in the world. Changing the service type, the mode, and/or the modulation protocol involves simply selecting and launching the requisite computer program. A SDR PCIx Host Card is shown in [Figure 1](#).

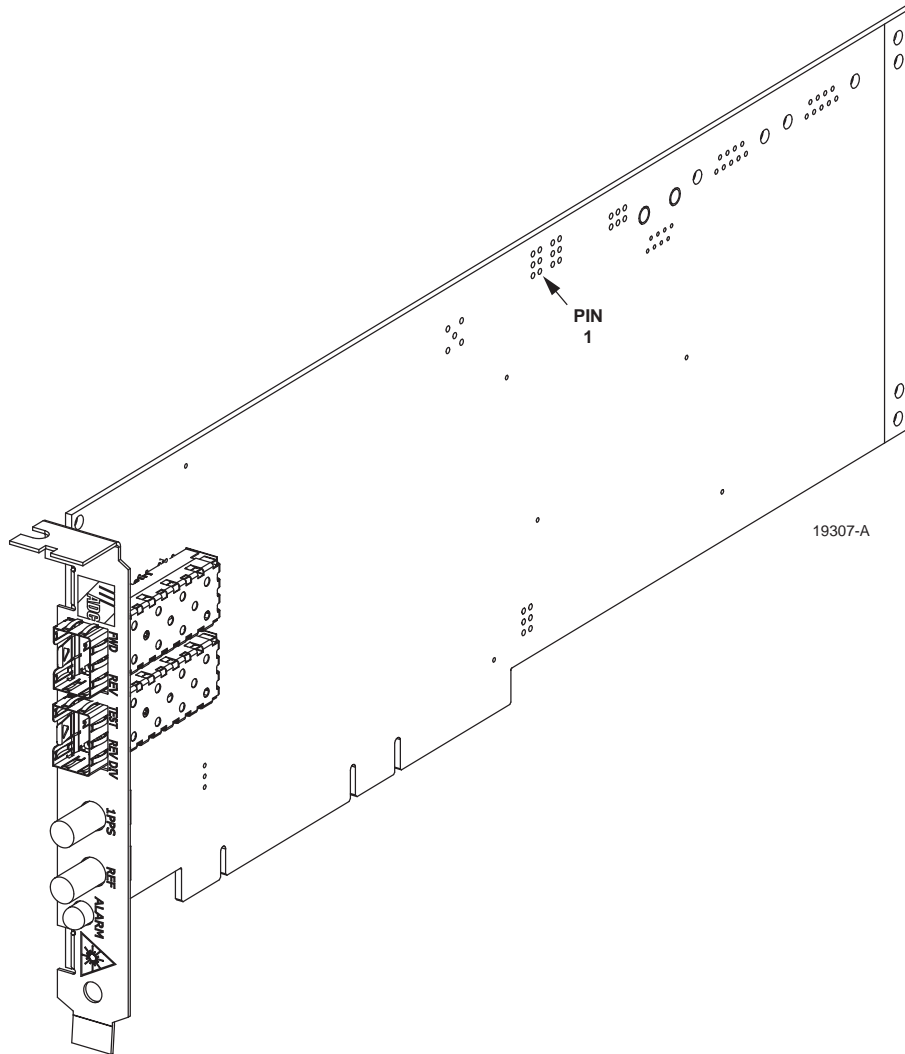

Figure 1. SDR PCIx Host Card

Software Defined Radio (SDR) allows a single device to adapt to different communications environments and systems by selecting the most appropriate protocol and frequency needed for a link. One device may work with a wireless local area network protocol in the city, and then be reconfigured to work with terrestrial and satellite protocols to deliver broadband applications to rural and remote areas.

SDR works much like desktop computing, where a single hardware platform carries out many functions based on the software applications loaded. SDR uses software to perform radio-signal

processing functions instead of using resistors, capacitors, feedback loops, or application-specific integrated circuits.

The SDR PCIx host card is installed in a server and cabled to the LRCS remote (radio head) units and the GPS receiver. Power is provided by the server with configuration and software management through the server communications interface. Communications with the network is through the server and associated hardware and software.

2 SDR CARD INSTALLATION

2.1 Power Down the Server



Warning: *To reduce the risk of personal injury, electric shock, or damage to the equipment, remove the power cord to remove power from the server. The front panel Power On switch may not completely shut off system power. Portions of the power supply and some internal circuitry may remain active until AC power is removed.*

1. Back up the server data.
2. Shut down the operating system as directed by the operating system documentation.
3. If the server is installed in a rack, locate the server.
4. Some servers may have a standby mode, if your server has a standby mode, press the Power On/Standby button to place the server in standby mode. When the server activates standby power mode, the system power LED should indicate the change to standby mode.
5. Disconnect the power cords. Server is now without power.

2.2 Extend Server from the Rack

Loosen the thumbscrews that secure the server faceplate to the front of the rack. Extend the server on the rack rails until the server rail-release latches engage.



Warning: *To reduce the risk of personal injury or equipment damage, be sure that the rack is adequately stabilized before extending a component from the rack.*

Warning: *To reduce the risk of personal injury, be careful when pressing the server rail-release latches and sliding server into the rack. The sliding rails could pinch your fingers.*

2.3 Remove Access Panel



Warning: *To reduce the risk of personal injury from hot surfaces, allow the drives and the internal system components to cool before touching them.*



Caution: *Do not operate the server for long periods without the access panel. Operating the server without the access panel results in improper airflow and improper cooling that can lead to thermal damage.*

Lift up on the hood latch handle and remove the access panel.

2.4 Remove PCI Riser Cage



Caution: *To prevent damage to the server or expansion boards, power down the server and remove all AC or DC power cords before removing or installing the PCI riser cage.*

1. If necessary, disconnect any internal or external cables connected to all expansion boards.
2. Lift the PCI riser cage thumbscrews and turn them counter-clockwise.
3. Remove the PCI riser cage.

2.5 Remove Expansion Slot Cover

Most servers contain a PCI-X backplane that is part of the PCI riser cage. The PCI backplane normally provides hot-plug capability to two expansion slots and a third non-hot-plug expansion slot. SDR PCIx Host card is installed in the non-hot-plug PCI-X expansion slot that meets the specification; 64-bit/133-MHz 3.3V. Determine which slot the SDR card is to be installed in and remove the expansion slot cover.



Caution: *To prevent improper cooling and thermal damage, do not operate the server unless all PCI slots have either an expansion slot cover or an expansion board installed.*

2.6 Installing a SDR PCIx Host Card



Caution: *Electronic modules can be damaged by electrostatic discharge (ESD). To prevent this, take the following precautions:*

- *Wear an anti-static-discharge wrist strap while handling modules.*
 - *Place modules in anti-static packing material when transporting or storing them.*
1. Slip on an Electro-Static Discharge (ESD) wrist strap and connect the ground wire to an earth ground source. Wear the ESD wrist strap while completing the SDR PCIx Host Card installation procedure.
 2. Unlock the PCI retaining clip.
 3. Install the card.
 4. Lock the PCI retaining clip.
 5. Power, network interface, and communications to the card are supplied through the card edge connector.

2.7 Install PCI Riser Cage



Caution: *To prevent damage to the server or expansion boards, power down the server and remove all AC power cords before removing or installing the PCI riser cage.*

1. Align the PCI riser cage with the chassis and slide it into place.
2. Tighten the screws to secure the PCI riser cage.

2.8 Install Access Panel

1. Place the access panel on top of the server with the hood latch open.
2. Push down on the hood latch. The access panel slides to a closed position.

2.9 Slide Server Into Rack

After performing the SDR PCIx Host card installation procedure, slide server back into the rack:

1. Press the server rail-release latches and slide the server fully into rack.
2. Secure the server by tightening the thumbscrews.

3 SDR PCIx HOST CARD CABLING

3.1 Optical and Electrical Connections

Optical and electrical connections with the remote unit and GPS are supported by four optical and two electrical ports. The electrical interface to the GPS is through coaxial cable connections using two type SubMiniature version A (SMA) female connectors. Single-mode fiber provides the optical connection between the SDR PCIx Host Card and Remote Units. The forward and reverse ports provide the optical communication channel in a non-diversity system. The REV DIV port provides receive optics for a diversity system. Each optical port uses a small form factor LC-type optical transceiver. Modular optical transceivers are field replaceable and available separately.

3.2 Coax Cabling

3.2.1 Coaxial Cable Requirements

The SDR PCIx Host card is equipped with SMA-type female 50-Ohm connectors for connecting the timing input/output signals from the GPS unit. High performance, flexible, low loss 50-ohm coaxial communications cable (RG316 or equivalent) should be used for all coaxial connections.

3.2.2 Coaxial Cable Connections

The RF interface between SDR PCIx Host card and the GPS is supported through a pair of type SMA female connectors mounted on the DHU front panel. One connector provides the coaxial cable connection for the REF (10 MHz sine wave) signal. The other connector provides the coaxial cable connection for the PPS (1 pulse per second) signal. Use the following procedure to install the coaxial cables and connect them to the DHU:

1. Obtain the required lengths of high performance, flexible, low loss 50-ohm coaxial communications cable (RG316 or equivalent) for all coaxial connections.

2. Route the timing input/output coaxial cables (if not already routed) between the SDR PCIx Host card and the GPS interface device (per system design) and cut to the required length. Allow sufficient slack for dressing and organizing cables at the SDR PCIx Host card.
3. Terminate each cable end with the appropriate male connector following the connector supplier's recommendations.
4. Connect the cables to the connectors on the SDR PCIx Host card as shown in [Figure 2](#).

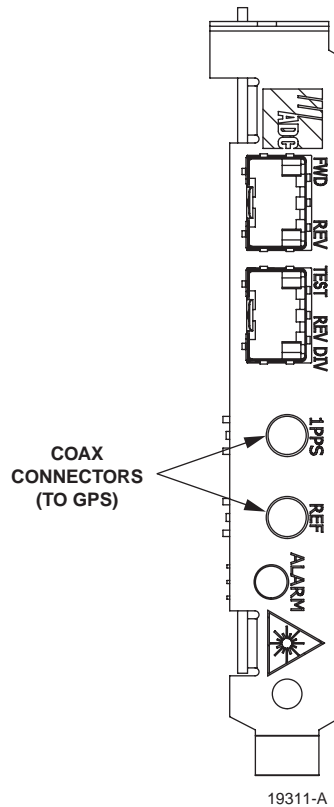

Figure 2. Coax Connectors

5. Dress and secure cables at the SDR PCIx Host card per standard industry practice.
6. Connect the coax cables to GPS receiver as specified in instructions provided with that unit.

3.3 Optical Cabling

3.3.1 Optical Options and Requirements

Each SDR PCIx Host Card and its associated remote (radio head) unit is connected over a pair of optical fibers. One fiber transports the forward path optical signal and the other fiber transports the reverse path optical signal. When diversity is used a third fiber is connected to the REV DIV port. 9/125 single-mode optical fiber is used for the optical transport connection. With 9/125 single-mode fiber, the optical path may be up to 10 kilometers in length. Optical

fibers must be terminated with duplex LC connectors for connection with the SDR card. Remote unit has SC connectors.

The maximum length of the optical links is dependent on the loss specifications of the optical fiber and the losses imposed by the various connectors and splices. The system provides an optical budget of **20dB** (typical) when used with 9/125 single-mode fiber.

Whenever possible, use conduit or a guideway to route optical fibers between the SDR PCIx Host card and the remote (radio head) unit. Avoid routing optical fibers through ladder type cable racks or troughs that do not provide sufficient support to limit bending or prevent accidental damage. Tie-wrapping is not recommended as a means of securing fiber optic cables. Provide sufficient slack at each unit for connecting each fiber to the required port. Fibers may be pre-terminated or terminated on-site using field-installable LC type connectors.

3.3.2 Optical Connections

The optical interface between the SDR PCIx Host card and the remote (radio head) unit is supported by two optical ports. Each of the SDR PCIx Host card optical ports provides a duplex LC-type optical transceiver which is mounted on the SDR PCIx Host card front. The remote (radio head) unit has SC connectors.

- ▶ **Note:** To insure that all optical connectors and transceivers remain dust-free during installation, leave all dust caps and dust protectors in place until directed to remove them for connection.

The FWD and REV ports provide forward and reverse optical communications channels in a non-diversity system. The REV DIV port provides receive optics for a diversity system. See [Table 1](#) for transceiver port designations. See [Figure 3](#) for port designations.

Table 1. Transceiver Port Designations

DESIGNATION	DIRECTION	REMARKS
FWD	Output	Forward path (downlink) signal.
REV	Input	Reverse path (uplink) signal.
TEST	Not used	
REV DIV	Input	Receive optics.



Danger: *This equipment uses a Class 1 Laser according to FDA/CDRH rules. Laser radiation can seriously damage the retina of the eye. Do not look into the ends of any optical fiber. Do not look directly into the optical transceiver of any digital unit or exposure to laser radiation may result. An optical power meter should be used to verify active fibers. A protective cap or hood MUST be immediately placed over any radiating transceiver or optical fiber connector to avoid the potential of dangerous amounts of radiation exposure. This practice also prevents dirt particles from entering the transceiver or connector.*

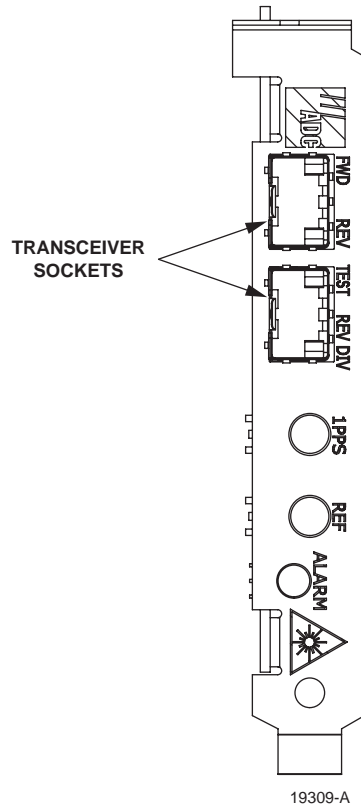

Figure 3. Optical Ports (Transceiver Sockets)

Use the following procedure to install the forward and reverse path optical fibers and to connect them to the SDR PCIx Host card:

1. Obtain the required lengths of single-mode fiber optic cable.
 2. Route the fiber optic cable between the SDR PCIx Host card and the remote (radio head) unit (if not already routed) and cut to required length. Allow sufficient slack for dressing and organizing the cables at each unit. Maintain a minimum bend radius of 2 inches (50 mm).
- **Note:** Maximum path length for 9/125 single-mode fiber optical fiber is 10 km (32,808 ft.).
3. Terminate each optical fiber with a field-installable LC type fiber optic connector as shown in [Figure 4](#). Follow the instructions provided by the connector manufacturer for installing the connector.
 4. Test each fiber for optical loss.
 5. Designate one of the fibers as the forward path fiber and the other as the reverse path fiber and label both ends of each fiber with the path designation.
 6. Use the plastic joiner provided with the LC connectors to join the SDR PCIx Host card forward and reverse path connectors together (see [Figure 4](#)). Make sure the forward path and reverse path connectors are oriented as shown.

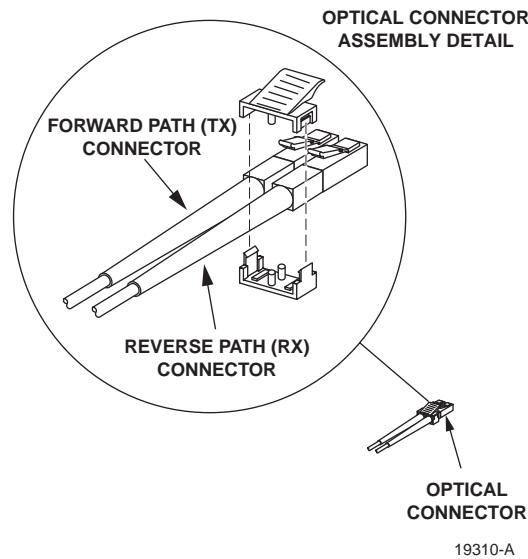

Figure 4. Terminate Optical Fiber

7. Remove dust caps from the optical fiber connectors and the primary optical transceiver.
 - ▶ **Note:** Leave the dust cap in place on any unused optical transceiver.
8. Clean each connector (follow connector supplier's recommendations) and then insert the optical fiber connector pair into SDR PCIx Host card optical FWD/REV port.
9. Place the optical fibers within the cable guides provided on the cable management tray and then dress and secure the fibers at the SDR PCIx Host card per standard industry practice.
10. Connect the forward and reverse path optical fibers to the remote (radio head) unit as specified in the instructions provided with that unit.
 - ▶ **Note:** To prevent damage to the remote optical receiver, there must be at least 15dB of attenuation at the optical receiver port.
11. Use the designation card provided to indicate the location and name of the remote (radio head) unit that is connected to the SDR PCIx Host card. The designation card holder may be attached to any convenient flat surface.

3.4 Modular Optical Transceiver Installation

The modular optical transceivers are available separately and may or may not be installed in the SDR PCIx Host Card depending on the configuration ordered. If the optical transceivers are factory installed in the SDR PCIx Host Card, skip this section and proceed to [Section 3.3.2 Optical Connections on page 9](#). If the optical transceivers are not factory installed, use the following procedure to install each transceiver:

1. Slip on an Electro-Static Discharge (ESD) wrist strap and connect the ground wire to an earth ground source. Wear the ESD wrist strap while completing the optical transceiver installation procedure.



Warning: *Electronic components can be damaged by static electrical discharge. To prevent ESD damage, always wear an ESD wrist strap when handling electronic components.*

2. Locate the appropriate transceiver socket on the front of the SDR card as shown in [Figure 5](#) and remove the cover from the socket.

► **Note:** A variety of optical transceivers are available, all provide the same functionality. On the type A optical transceiver, the release lever (see [Figure 5](#)) must be closed for installation.

3. Select optical transceivers shown in [Figure 5](#).

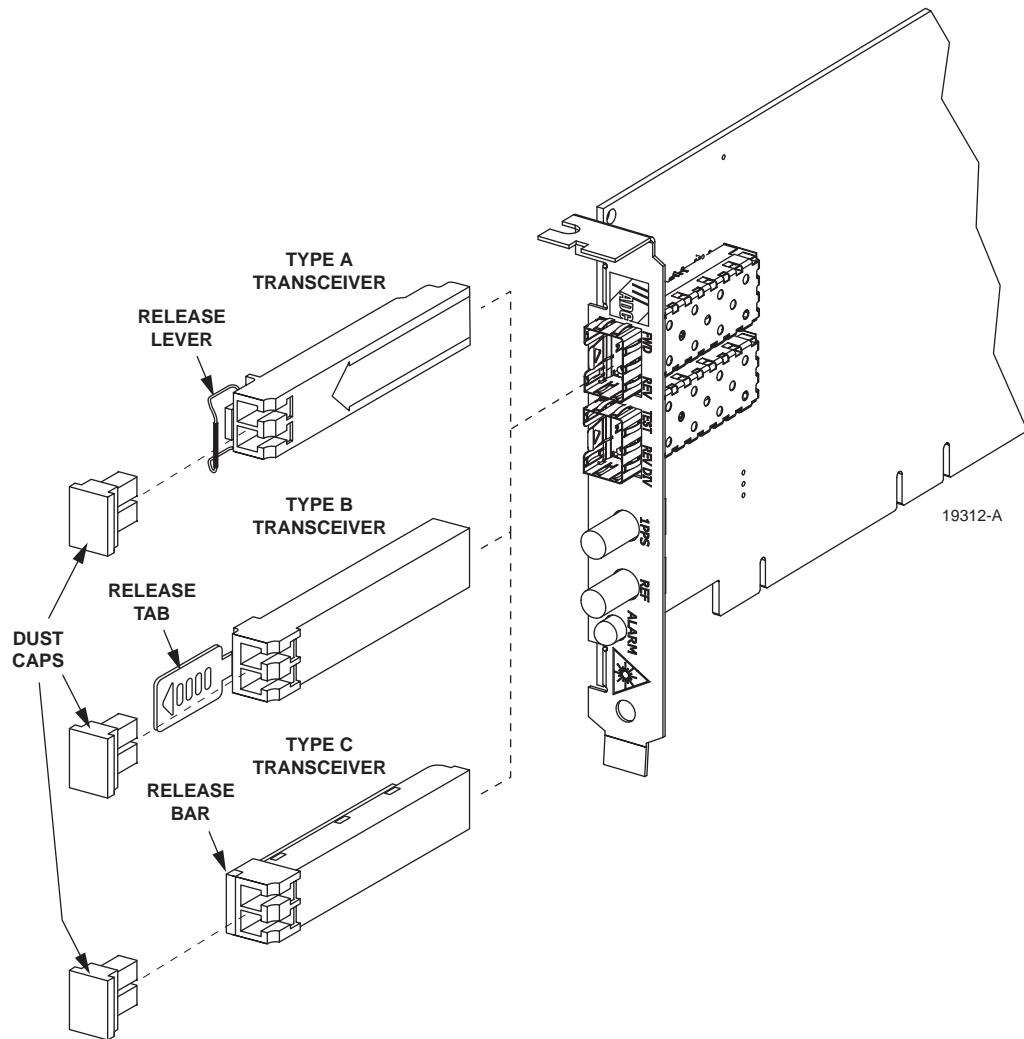

Figure 5. Optical Transceiver Installation

4. Remove transceiver from anti-static packaging and orient for installation. See [Figure 5](#).
5. Insert the optical transceiver into the socket until it locks into place.
6. Replace the optical transceiver dust cap if it was removed for installation.
7. Repeat procedure for each optical transceiver that requires installation.

4 POWERING UP THE SERVER

To power up the server, connect power cord and move the start/on button to the ON position.

5 GAIN CONFIGURATION PARAMETERS

The EMS allows the user to configure forward, reverse, and diversity path gain settings on the Host PCIx card within the valid ranges.

5.1 Gain (Attenuation)

Gain is configured on a per channel basis and is independent for each Tx, Rx, and Rx diversity channel. Gain ranges for forward and reverse paths are shown below:

Primary Forward Path Range: 10 to –20dB

Primary Reverse Path Range: 0 to –30dB

Secondary Reverse (Diversity) Path Range: 0 to –30dB

5.2 Wide-band Gain (Attenuation)

Wide-band Gain is set at the Remote Unit, range is 0 to –30dB in increments of 1dB.

6 OPERATION

All operation of the SDR PCIx Host card is through the software. Use the software utilities to configure new hardware in the system. For more configuration information, refer to the software documentation.

6.1 Alarm LED

Under normal operation the Alarm LED is green. Alarm indicator is defined in [Table 2](#).

Table 2. LED Indicators

COLOR	STATUS
RED	SDR PCIx Host card failure
YELLOW	Minor alarm
GREEN	Normal operation
OFF	Power OFF

7 SPECIFICATIONS

- **Note:** To comply with Maximum Permissible Exposure (MPE) requirements, the maximum composite output from the antenna cannot exceed 1000 Watts EIRP and the antenna must be permanently installed in a fixed location that provides at least **6 meters** (20 feet) of separation from all persons.

Specifications for the LRCS SDR PCIx Host Card are listed in [Table 3](#).

Table 3. PCIx Host Card Specifications

PARAMETER	SPECIFICATION	REMARKS
RF Forward Path - 800 MHz System		
Bandwidth A band B band	11 and 1.5 MHz 10 and 2.5 MHz	
Frequency range A band B band	869–880 and 890–891.5 MHz 880–890 and 891.5–894 MHz	
Out-of-band emissions Primary Secondary	–13 dBm per 1 MHz bandwidth from 10 kHz to 20 GHz –98 dBm per 100 kHz from 824 to 849 MHz	
Gain of forward path (Host input to Remote primary antenna port)	84.5 dB with 50 Watt LPA	At band center, room tempera- ture, and 0 dB attenuation setting. Includes power amplifier.
Gain flatness Band flatness Channel flatness	± 2.0 dB across freq. range ± 1 dB variation across any 1.25 MHz channel	
Gain variation	± 3 dB over temp and unit-to-unit	
Out-of-band rejection	–40 dB at ≥ ±17.5 MHz from cen- ter of subband	
Propagation delay	6 μs	Excludes fiber delay

Table 3. PCIx Host Card Specifications

PARAMETER	SPECIFICATION	REMARKS
Configurable propagation delay Range Step size	Up to 63 μ s 0.1 μ s \pm 100 ns	Plus standard propagation delay
Spurious In-band self generated Free dynamic range	-13 dBm at remote output 60 dB at 30 kHz bandwidth	
Transmit peak-to-average	10 dB	
Two-tone Intermodulation	-55 dBc at remote output	Two tones at 5 Watts each
Nominal composite RF input signal level	-40 dBm at 0 dB attenuation -9 dBm at max. attenuation	An input signal level of -40 dBm provides maximum output power
Configurable input level Range Step size	31 dB 1 \pm 0.5 dB \pm 10% of attenuation monotonic	
Composite RF Output power With 50 Watt LPA	44.5 dBm (28.5 Watts) at remote antenna port with -40 dBm input	50 Watts at LPA output
Configurable RF Output Range Step size	31 dB at remote unit 1 \pm 0.5 dB \pm 10% of attenuation monotonic	
Transmit path insertion loss	2.5 dB	
RF Reverse Path - 800 MHz		
Bandwidth A band B band	11 and 1.5 MHz 10 and 2.5 MHz	
Frequency range A band B band	824-835 and 845-846.5 MHz 835-845 and 846.5-849 MHz	
In band spurs (caused by an individual out-of-band signal)	-75 dBc (1 MHz to 20 GHz and > 10 MHz out-of-band) -120 dBc (869 to 894 MHz)	
Propagation delay	6 μ s	Excludes fiber delay
Configurable propagation delay Range Step size	Up to 63 μ s 0.1 μ s \pm 1 100 ns	Plus standard propagation delay
Gain flatness Band flatness Channel flatness	1.5 dB across frequency range \pm 1 dB variation across any 1.25 MHz channel	
Gain of reverse path Overall gain Gain variation	30 \pm 2 dB at band center at room temperature 3 dB over temperature	ALC not invoked ALC not invoked

Table 3. PCIx Host Card Specifications

PARAMETER	SPECIFICATION	REMARKS
Out-of-band rejection	-40 dB at $\geq \pm 17.5$ MHz from center of subband	ALC not invoked
Spurious (in-band self generated)	-110 dBm referred to input	ALC not invoked
Intermodulation	-62 dBc two tones at -50 dBm	
System noise figure	9 dB at mid-band	ALC not invoked
Configurable RF output Range Step size	31 dB 1 ± 0.5 dB $\pm 10\%$ of attenuation monotonic	
Blocking dynamic range	70 dB	
Level limiting ALC threshold	-40 dBm ± 3 dB instantaneous	
Level limiting ALC range	30 dB	
RF Forward and Reverse Path Modulation Accuracy		
Service/Mod Type/Parameter GSM/GMSK/rms phase error	4°	
Environmental		
Operating Conditions	+32°F to +122°F (0°C to +50°C)	Any server may be used that operates in this range.

8 CUSTOMER INFORMATION AND ASSISTANCE

PHONE:

EUROPE

Sales Administration: +32-2-712-65 00

Technical Assistance: +32-2-712-65 42

EUROPEAN TOLL FREE NUMBERS

Germany: 0180 2232923

UK: 0800 960236

Spain: 900 983291

France: 0800 914032

Italy: 0800 782374

U.S.A. OR CANADA

Sales: 1-800-366-3891 Extension 73000

Technical Assistance: 1-800-366-3891

└ Connectivity Extension 73475

└ Wireless Extension 73476

ASIA/PACIFIC

Sales Administration: +65-6294-9948

Technical Assistance: +65-6393-0739

ELSEWHERE

Sales Administration: +1-952-938-8080

Technical Assistance: +1-952-917-3475

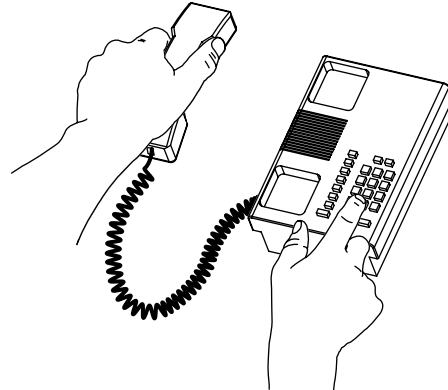

WRITE:

ADC TELECOMMUNICATIONS, INC
PO BOX 1101,
MINNEAPOLIS, MN 55440-1101, USA

ADC TELECOMMUNICATIONS (S'PORE) PTE. LTD.
100 BEACH ROAD, #18-01, SHAW TOWERS.
SINGAPORE 189702.

ADC EUROPEAN CUSTOMER SERVICE, INC
BELGICASTRAAT 2,
1930 ZAVENTEM, BELGIUM

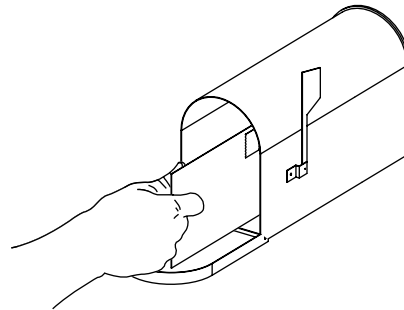

PRODUCT INFORMATION AND TECHNICAL ASSISTANCE:

connectivity_tac@adc.com

wireless_tac@adc.com

euro_tac@adc.com

asiapacific_tac@adc.com

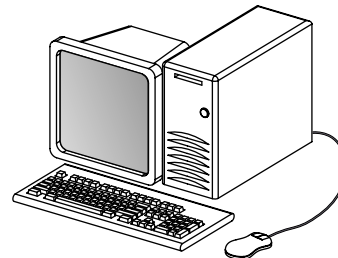

13944-L

Contents herein are current as of the date of publication. ADC reserves the right to change the contents without prior notice. In no event shall ADC be liable for any damages resulting from loss of data, loss of use, or loss of profits and ADC further disclaims any and all liability for indirect, incidental, special, consequential or other similar damages. This disclaimer of liability applies to all products, publications and services during and after the warranty period. This publication may be verified at any time by contacting ADC's Technical Assistance Center.

