

SELECTRA *PRO*
M

**Read this document step by step before installing the instrument
and keep it for later reference.**

© 2015 ELITechGroup B.V.

All rights reserved.

No part of this publication may be re-produced and/or published by being printed, photocopied, placed on microfilm or in any other manner without the prior written permission of ELITechGroup B.V. This also applies to the appended drawings and diagrams.

ELITechGroup B.V. retains the right to make changes in parts at any point without first or directly notifying the customer. The contents of this instruction can also be changed without prior warning.

This instruction is valid for the analyzer installation in its standard version. ELITechGroup B.V. can therefore not be held liable for specifications of the delivered system that may deviate from the standard version.

The analyzer was conceptualized, manufactured and tested in accordance with the declaration of conformity. The declaration of conformity is supplied with each device in a separate file.

This instrument (excluding the computer) conforms to the provisions of the EU Directive on In Vitro Diagnostic Medical Devices (98/79/EC) of the European Parliament and the Council of 27 October 1998. The declaration of conformity is supplied with each device in a separate file.

Manufacturer:
ELITechGroup B.V.
van Rensselaerweg 4
6956 AV Spankeren
P.O. Box 100
6950 AC Dieren
The Netherlands
Tel.: +31 313 430 500
Fax: +31 313 427 807
E-mail: service.ecsnl@elitechgroup.com
Website: www.elitechgroup.com

Safety precautions

Warning

- The analyser and optional additional devices, parts and accessories are shipped in a single transport box. A qualified service technician from the manufacturer or his designated representative is allowed to unpack and install the analyser. If these instructions are not being followed, the manufacturer does not accept responsibility for damage due to improper installation or improper operation of the analyser.
- Take care when lifting, removing or installing the analyser. The weight of the analyser is 95 kg. Make sure there are enough people available to lift the analyser safely. Consult local sources for additional information regarding safety regulations in the workplace.
- Only instruments that meet the relevant safety requirements may be connected to the analyser. Only use UL-listed power supply cable and power distribution blocks.
- Do not use the analyser in close proximity to sources of strong electromagnetic radiation (e.g. unshielded intentional RF sources), as these may interfere with the proper operation.

Attention

- The analyser is a bench model instrument and has to be installed on a level surface.
- For the line voltage, a reliable 96V – 264V (50Hz – 60Hz) connection must be available. Make sure that the analyzer and peripheral equipment is well grounded.
- It is recommended to use an Uninterruptible Power Supply (UPS), supplying power from a separate source when utility power is not available.
- Do not place the analyser against a wall. There must be access available at all times to the rear access panels of the analyser. Make sure the power cord is accessible and there is free circulation of ventilation air. Adequate ventilation of the room is recommended to prevent condensation occurring at the analyser parts.
- The analyser shall not be exposed to direct sunlight or vibrations.
- Use distilled or purified water (at least ASTM type II grade water). This water must be available at the installation site.
- Avoid extreme high or low temperature and humidity.
(Ambient temperature 15 - 32°C, maximum altitude of 3000 meter and maximum relative humidity 80% at 32°C non-condensing)

Packaging

Accessory box;

Check the contents with the enclosed packing list.



Panel PC (PPC);

The box contains:

- panel PC (PPC)
- external power supply unit
- touch stylus pen
- remote control

Keyboard Support (optional);

The box contains;

- keyboard support
- bag with 4x M4 washers

External Waste Kit (optional);

The box contains;

- 10 liter water container
- water tube assy
- waste by-pass connector
- waste tube assy

Note: Major damage or missing parts must be filled-in on the Installation Report which comes with the analyser.

Installation

The following procedure describes the recommended method to install the analyser. Shown pictures could differ from reality. Described procedure is leading.

Info: Depending on the configuration (e.g. with optional external waste kit and/or optional concentrated waste kit) follow step 1-5 when applicable.

Installing water and waste containers

1. Attach the "Water" sticker to the 5 liter container as shown. Pour 12.5ml system solution (SLSY-5900) into the container and add distilled water until the water container is full. Connect the tubes in accordance with the numbers as mentioned on the connection plate.
2. Attach the "Diluted Waste" and the "Biohazard" sticker to the 5 liter container. Connect the diluted waste level sensor connector and the tubes in accordance with the numbers as mentioned on the connection plate.

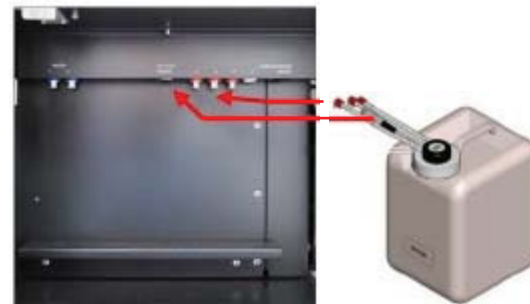
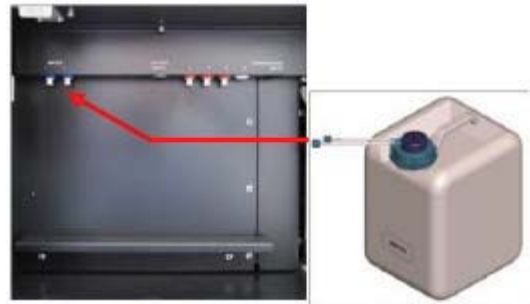

Installing optional External Waste kit

3. Connect the tubes of the external waste and the diluted waste bypass connector in accordance as mentioned on the connection plate. Open the right panel and lead the tubes via a special cut-out in the frame opening and close the panel. Put the tubes into the drain.

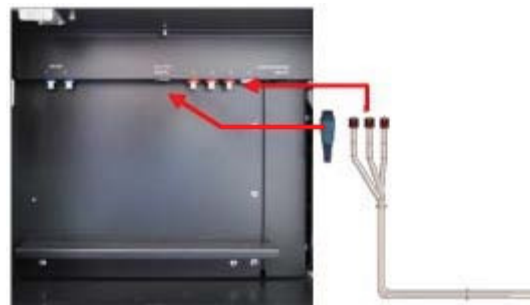

4. Attach the "Water" sticker to the 10 liter container. Pour 25ml system solution (SLSY-5900) into the container and add distilled water until the water container is full. Connect the tubes in accordance with the numbers as mentioned on the connection plate. Place the container outside the instrument and lead the tubes as described at step3.

Installing optional Concentrated Waste kit

5. Attach the "Concentrated Waste" and the "Biohazard" sticker to the 2 liter container. Connect the level sensor connector and tubes in accordance with the numbers mentioned on the connection plate. Place the container outside the instrument and lead the tubes as described at step3.

Mounting the panel PC (PPC) and optional Keyboard Support

The package of the monitor arm contains; the arm, a plastic bag (with tools and mounting parts).

6. Place the PPC carefully on his front side on a clean table (use protection material to avoid scratches at the PPC).

Note: When an optional Keyboard Support is ordered follow step 6a otherwise continue with step 6b.

- 6a. Place the keyboard support on the backside of the PPC keeping it with one hand in position and place the monitor arm on top.
Use the big-sized M4 x 10 screws with M4 washers and fasten both parts to the PPC. Tighten all screws when all are in position.



- 6b. Assemble the monitor arm to the PPC with enclosed 4x small-sized M4 x 5 screws and M4 washers.

7. The monitor arm is positioned on the post on the analyzer and fixed with 2 washers and a stainless steel bolt.

Place the white Plastic bush (A) around the post.

Take the PPC with monitor arm and optional keyboard support and position it on the post.

Take the 2 washers and place them around the stainless steel bolt, as shown.

Fasten the bolt using the enclosed Allen head key. Make sure that the monitor arm can be moved smoothly in a horizontal way.

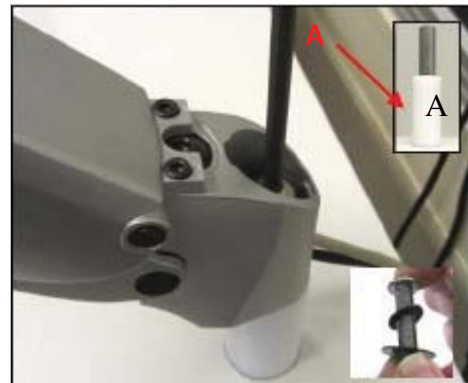

Note: The bigger washer is bolded and must be mounted with the bolded side upwards.

Adjust the monitorarm.

Depending on the weight of the PPC, adjustments may be required to the pivot joint mechanism and/or the arm.

Note: When performing the adjustment, the arm must be in a horizontal position.

8. If the monitor doesn't hold its position or is too tight, adjust the tension screw located on top of the pivot joint. Adjust with intermittency check if it hold the monitor.

Turn the screw clockwise to tighten.
Turn the screw anti-clockwise to loosen.

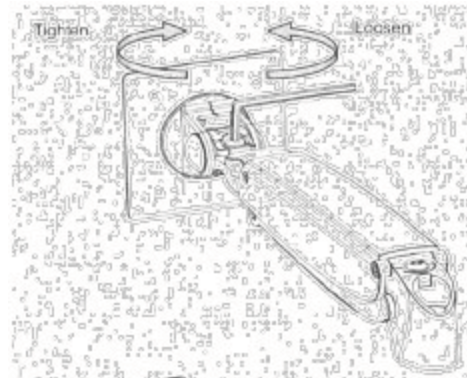

9. If the arm tends to drift down or rise up when positioned, it will be necessary to make small adjustment at the adjustment screw. The provided Allen head key can be used for this adjustment.

If the arm tends to rise, turn the screw clockwise to decrease the tension.
If the arm tends to fall, turn the screw anti-clockwise to increase the tension.

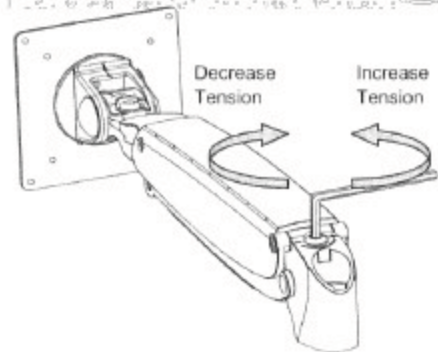

Panel PC connections and cable guide.

10. Connect the USB keyboard (D), power cable (A), serial null-cable (B, COM 1) and applicable USB printer cable to the panel PC (D).

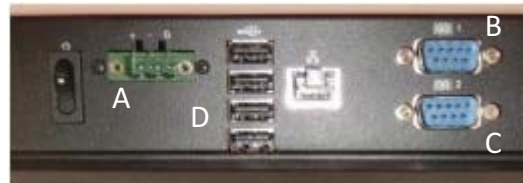

Note: Do not connect the serial null-modem cable into com-port 2 (C). This port will not be used for normal routine operation/connection.

11. Put the cable(s) into the arm inside, place Holding Tab (A) at the bottom of the arm, slide from the middle inlet to the end of each side.

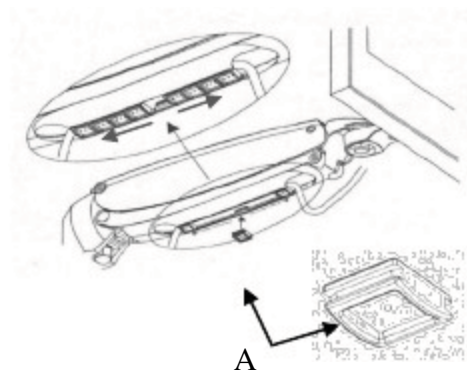

12. Attach the power cable and the serial null-modem cable from the panel PC to the analyzer.

Connect the power cable to the mains.

Note: DO NOT switch on the analyzer.



Mounting Syringes

Take out both the syringes from the packaging.

Note: The syringes are fragile.

13. Remove the screw (A) from the drive pin. Moisten the inside of the glass barrel of the syringe with distilled water. Pull distilled water into the syringe. There should be at least 4 cm of water on top the plunger. Remove air bubbles from the tip of the plunger. Push the plunger handle over the pin drive and fix it with the removed screw. Pull the glass barrel straight up and screw it into the valve block (B) holding the syringe at the metal part of the syringe. Repeat this step for the second syringe.

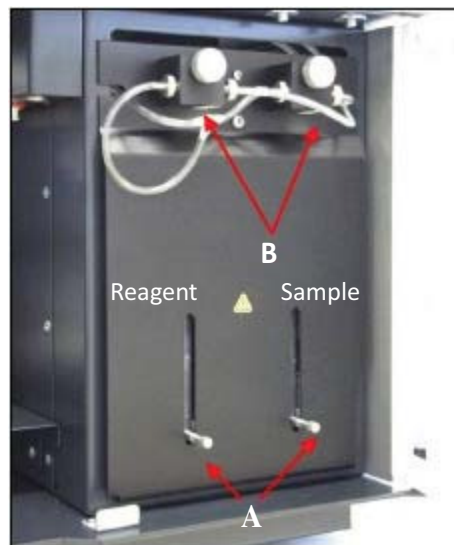

Placing Cuvette Rotor

14. Remove the cuvette rotor cover.

Lift the wash arm and mixer unit manually until its maximum possible height.

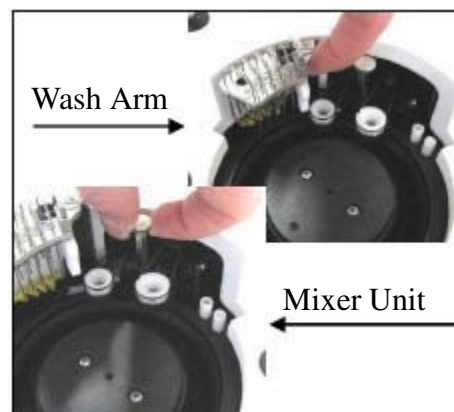

15. Take 1 cuvette rotor out of the package keeping it at the center knob.

Note: Never touch the inside or outside of the cuvettes with your fingers.

16. Put the cuvette rotor into place focusing at 1 slit and ridge (the cuvette rotor has 4 ridges which must position into the slits of the rotor).

Note: Do not rotate the cuvette rotor finding the slit. This will probably damage the cuvette rotor and cannot be used anymore. Push down the stirrer unit and the wash arm to its normal height (as before).



Cooling preparations

Take the 1L cooling liquid (based on Glycerol) from the accessory box.

Prepare in total 100mL of a 1:4 dilution using 25mL cooling liquid and 75mL distilled water.

Filling Cooling Unit

17. Take off the front panel by lifting it up and towards you.



18. Remove the cap from the cooling barrel.
Switch on the analyzer (cooling pump will start). Do not switch on the PPC.
Fill the barrel with the prepared cooling mixture until the high level is reached.
Due to air bubbles inside the tubing's it might be necessary to refill the system a few times.



When the level remains constant, cap the barrel and assemble the front panel.
Switch off the analyzer.

Info: When the instrument is equipped with the optional Dry Electrode ISE Unit continue with the step 19 otherwise go to step **Installing Application Software and Test Parameters**.

Optional Dry Electrode ISE Unit

19. Follow the instructions as described in the User Manual how to install all concerned parts.



Remove the ISE sipper transport safety bracket

20. The ISE sipper is secured with a bracket for transportation. It is required to remove this bracket before using the analyzer.

Unscrew the knurled nut (A).

Remove the bracket (B).

Screw the removed knurled nut (A).

For possible later use put away the bracket in the assorter kit which comes with the instrument.

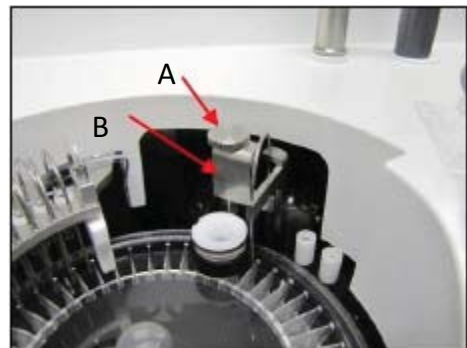

Installing Application Software and Test Parameters.

The application software and the ELITech test parameters are pre-installed on an USB-flash drive that can be found in the accessory box.

21. Switch on the analyzer and panel PC (PPC).
22. Login into the Maintenance account. (account has Administrator rights)
(Default password is : netherlands)
23. Disable the File Based Write Filter. (FBWF)
(More details about the FBWF are available in the service manual)

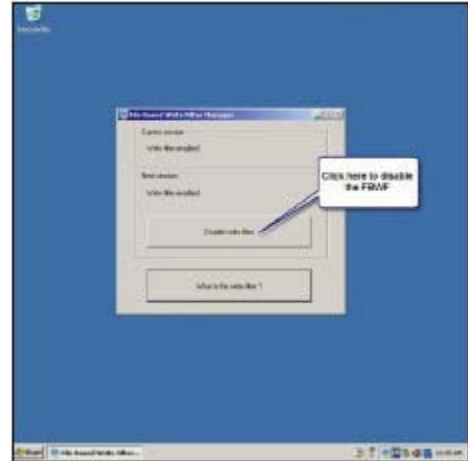

24. Click [OK].
The PPC will reboot automatically.

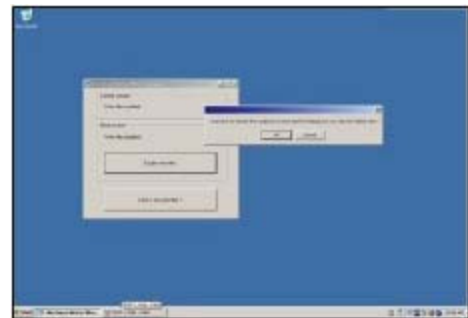

25. Login into the Maintenance account again.
26. Insert the USB key into a free USB port of the PPC.
27. Start the Windows Explorer.
(Right click on the Start button and select Explore)
28. Navigate to your USB key (Removable drive).
(Double click on setup.exe to startup the installation procedure)
29. Follow the instructions on the screen.
30. After installation of the Analyzer Application additional applications or printer drivers can be installed now.
31. Enable the File Based Write Filter (FBWF).
(More details about the FBWF are available in the Service Manual)

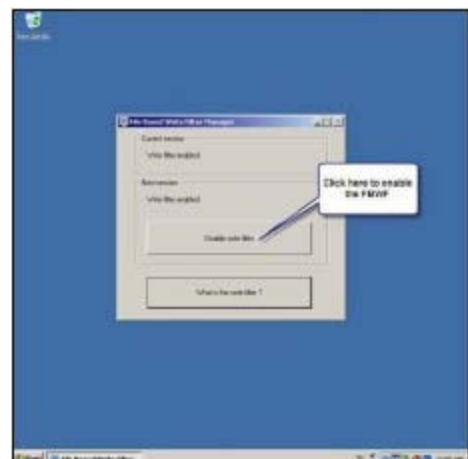

32. Click [OK].
The PPC will reboot automatically.
(Now the installation is finished and the analyzer software is ready to use)

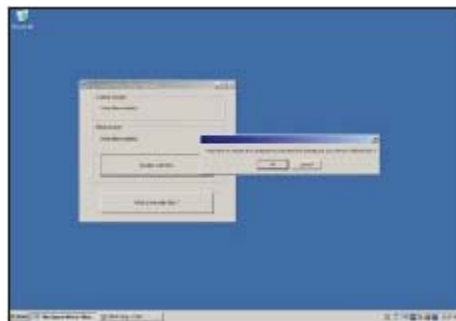

33. Login into the Analyzer Account.
(no password required)
34. Startup the analyzer software.
(Double click on the Elitech Clinical Systems icon on the desktop)
35. Import Test Parameters.
(TouchPro software: Open the Home screen, tap the Tasks, Routine Tasks, Export And Import, Tests tab. Tap the Import button. Navigate to your USB key and select the test parameter file (.csv). Select the methods you want to import and press [F3] to confirm.*
36. Software installation is complete.

Program the application (see User Manual).

For the correct working of the analyzer it is necessary to set the application, install cleaning solutions and run some tests/checks.

37. Set the "System Parameters" and "System Configuration".
Note: Check the order of the filter wheel configuration in the "System Configuration" with the sticker positioned at the inside of the water compartment door.
38. Run function "Fill System" (repeat if air bubbles are visible in tubes).
39. Install System Acid SLHC-5900 (HCL 0.1N) on the reagent rotor position 23.
40. Install Cleaning Solution SLNA-5900 diluted 10% as Needle Rinse Solution on the reagent rotor position 24 and sample rotor position "W".
41. Run the function "Rotor Blank".
42. Perform a SR3 and SR75 precision test using the supplied Dichromate solution. Report the results on the Installation Report.
(Tests are already pre-programmed but reagents needs to be installed)
43. Run Blank (reagent).
44. Run Calibrator(s).
45. Run Control(s).
Report the results on the Installation Report.

Complete the Installation Report by adding the remaining requested information and send it by email, fax or post to ELITechGroup B.V.

ELITechGroup B.V.
van Rensselaerweg 4
6956 AV Spankeren
P.O. Box 100
6950 AC Dieren
The Netherlands
Fax: +31 313 427 807
E-mail: service.ecsnl@elitechgroup.com

Disclaimer: This Installation Instruction has been completed with the greatest possible care. However we cannot accept any claim or liability based on the information in this Note or information we refer to.

Federal Communication Commission Interference Statement

This equipment has been tested and found to comply with the limits for a Class B digital device, pursuant to Part 15 of the FCC Rules. These limits are designed to provide reasonable protection against harmful interference in a residential installation. This equipment generates, uses and can radiate radio frequency energy and, if not installed and used in accordance with the instructions, may cause harmful interference to radio communications. However, there is no guarantee that interference will not occur in a particular installation. If this equipment does cause harmful interference to radio or television reception, which can be determined by turning the equipment off and on, the user is encouraged to try to correct the interference by one of the following measures:

- Reorient or relocate the receiving antenna.
- Increase the separation between the equipment and receiver.
- Connect the equipment into an outlet on a circuit different from that to which the receiver is connected.
- Consult the dealer or an experienced radio/TV technician for help.

This device complies with Part 15 of the FCC rules. Operation is subject to the following two conditions: (1) this device may not cause harmful interference, and (2) this device must accept any interference received, including interference that may cause undesired operation.

This device and its antenna(s) must not be co-located or operating in conjunction with any other antenna or transmitter.

Any changes or modifications not expressly approved by the party responsible for compliance could void the user's authority to operate this equipment.

If this device is going to be operated in 5.15 ~ 5.25 GHz frequency range, then it is restricted in indoor environment only.

IMPORTANT NOTE :

FCC Radiation Exposure Statement:

This equipment complies with FCC radiation exposure limits set forth for an uncontrolled environment. This equipment should be installed and operated with minimum distance 20cm between the radiator and your body.