



NetVanta 150 Series Hardware Installation Guide

1700412E1

NetVanta 150

Trademarks

Any brand names and product names included in this manual are trademarks, registered trademarks, or trade names of their respective holders.

To the Holder of the Manual

The contents of this manual are current as of the date of publication. ADTRAN reserves the right to change the contents without prior notice.

In no event will ADTRAN be liable for any special, incidental, or consequential damages or for commercial losses even if ADTRAN has been advised thereof as a result of issue of this publication.

Software Licensing Agreement

Each ADTRAN product contains a single license for ADTRAN supplied software. Pursuant to the Licensing Agreement, you may: (a) use the software on the purchased ADTRAN device only and (b) keep a copy of the software for backup purposes. This Agreement covers all software installed on the system as well as any software available on the ADTRAN website. In addition, certain ADTRAN systems may contain additional conditions for obtaining software upgrades.



Changes or modifications to this unit not expressly approved by the party responsible for compliance could void the user's authority to operate the equipment.



901 Explorer Boulevard
P.O. Box 140000
Huntsville, AL 35814-4000
Phone: (256) 963-8000

Copyright © 2006 ADTRAN, Inc.
All Rights Reserved.
Printed in U.S.A.

Conventions

**NOTE**

Notes provide additional useful information.

**CAUTION**

Cautions signify information that could prevent service interruption or damage to equipment.

WARNING

Warnings provide information that could prevent injury or endangerment to human life.

Safety Instructions

When using your telephone equipment, please follow these basic safety precautions to reduce the risk of fire, electrical shock, or personal injury:

1. Do not use this product near water, such as a bathtub, wash bowl, kitchen sink, laundry tub, in a wet basement, or near a swimming pool.
2. Avoid using a telephone (other than a cordless-type) during an electrical storm. There is a remote risk of shock from lightning.
3. Do not use the telephone to report a gas leak in the vicinity of the leak.
4. Use only the power cord, power supply, and/or batteries indicated in the manual. Do not dispose of batteries in a fire. They may explode. Check with local codes for special disposal instructions.
5. The socket-outlet shall be installed near the equipment and shall be easily accessible.

Save These Important Safety Instructions

FCC-Required Information

FCC regulations require that the following information be provided in this manual:

1. This equipment complies with Part 68 of FCC rules and requirements adopted by ACTA. Each registered interface has a label that contains, among other information, a product identifier in the format US:AAAEQ##TXXXX. If requested, provide this information to the telephone company.
2. If this equipment causes harm to the telephone network, the telephone company may temporarily discontinue service. If possible, advance notification is given; otherwise, notification is given as soon as possible. The telephone company will advise the customer of the right to file a complaint with the FCC.
3. The telephone company may make changes in its facilities, equipment, operations, or procedures that could effect the proper operation of this equipment. Advance notification and the opportunity to maintain uninterrupted service are given.
4. If experiencing difficulty with this equipment, please contact ADTRAN for repair and warranty information. The telephone company may require this equipment to be disconnected from the network until the problem is corrected or it is certain the equipment is not malfunctioning.
5. This unit contains no user-serviceable parts.
6. This equipment is designed to connect to the telephone network or premises wiring using an FCC-compatible modular jack, which is compliant with Part 68 and requirements adopted by ACTA.

FCC Radio Frequency Interference Statement

This equipment has been tested and found to comply with the limits for a Class B digital device, pursuant to Part 15 of the FCC Rules. These limits are designed to provide reasonable protection against harmful interference in a residential installation. This equipment generates, uses, and can radiate radio frequency energy and, if not installed and used in accordance with the instruction manual, may cause harmful interference to radio communications. However, there is no guarantee that interference will not occur in a particular installation. If this equipment does cause harmful interference to radio or television reception, which can be determined by turning the equipment off and on, the user is encouraged to try to correct the interference by one or more of the following measures:

- Reorient or relocate the receiving antenna.
- Increase the separation between the equipment and receiver.
- Connect the equipment into an outlet on a circuit different from that to which the receiver is connected.
- Consult the dealer or an experienced radio/TV technician for help.

FCC Compliance Notice: Radio Frequency Notice



This device complies with part 15 of the FCC Rules. Operation is subject to the following two conditions: 1. This device may not cause harmful interference. 2. This device must accept any interference received, including interference that may cause undesired operation.

Placement and Range Guidelines

The maximum indoor range for 802.11b devices is 500 feet (152.4m). However, the physical placement of your wireless access point (WAP) can affect the operating range of the unit. When determining the placement of your WAP, consider the following guidelines to avoid significant performance degradation or inability to wirelessly connect to the WAP:

- Place the WAP away from potential sources of interference, such as PCs, large metal surfaces, microwaves, and 2.4 GHz cordless phones.
- Place the WAP in an elevated location such as a high shelf that is near the center of the wireless coverage area for all mobile devices.

RF Exposure Warning for North America, and Australia

WARNING

To meet FCC and other national safety guidelines for RF exposure, the antennas for this device must be installed with a minimum separation distance of 7.9in (20cm) from any person. The antennas shall not be colocated with other antenna or radio transmitter.

You are cautioned that changes or modifications not expressly approved by the party responsible for compliance could void your authority to operate the equipment.

According to FCC 15.407(e), the device is intended to operate in the frequency band of 5.15GHz to 5.25GHz under all conditions of normal operation. Normal operation of this device is restricted to indoor used only to reduce any potential for harmful interference to co-channel MSS operations.

Industry Canada Compliance Information

The Industry Canada label applied to the product (identified by the Industry Canada logo or the “IC:” in front of the certification/registration number) signifies that the Industry Canada technical specifications were met.

The Ringer Equivalence Number (REN) for this terminal equipment is supplied in the documentation or on the product labeling/markings. The REN assigned to each terminal device indicates the maximum number of terminals that can be connected to a telephone interface. The termination on an interface may consist of any combination of devices subject only to the requirement that the sum of the RENs of all the devices should not exceed five (5).

Canadian Emissions Requirements

This digital apparatus does not exceed the Class B limits for radio noise emissions from digital apparatus as set out in the interference-causing equipment standard entitled “Digital Apparatus,” ICES-003 of the Department of Communications.

Cet appareil numérique respecte les limites de bruits radioélectriques applicables aux appareils numériques de Class A prescrites dans la norme sur le matériel brouilleur: “Appareils Numériques,” NMB-003 édictée par le ministre des Communications.

Warranty

ADTRAN will repair and return this product within the warranty period if it does not meet its published specifications or fails while in service. Warranty information can be found in the *Support* section of the ADTRAN website at <http://www.adtran.com>.

Product Registration

Registering your product helps ensure complete customer satisfaction. Please take time to register your products in the *Support* section of the ADTRAN website at <http://www.adtran.com>

Product Support Information

A return material authorization (RMA) is required prior to returning equipment to ADTRAN. For service, RMA requests, training, or more information, use the contact information shown below.

Repair and Return

If you determine that a repair is needed, please contact our Customer and Product Service (CaPS) department to have an RMA number issued. CaPS should also be contacted to obtain information regarding equipment currently in house or possible fees associated with repair.

CaPS Department (256) 963-8722

Identify the RMA number clearly on the package (below the address), and return to the following address:

ADTRAN Customer and Product Service
901 Explorer Blvd. (East Tower)
Huntsville, Alabama 35806

RMA # _____

Pre-Sale Inquiries and Applications Support

Your reseller should serve as the first point of contact for support. If additional pre-sales support is needed, the ADTRAN Support website provides a variety of support services such as a searchable knowledge base, the latest product documentation, application briefs, case studies, and a link to submit a question to an Applications Engineer. All of this, and more, is available in the *Support* section of the ADTRAN website at <http://www.adtran.com>.

When needed, further pre-sales assistance is available by calling our Applications Engineering Department.

Applications Engineering (800) 615-1176

Post-Sale Support

Your reseller should serve as the first point of contact for support. If additional support is needed, the ADTRAN website provides a variety of support services such as a searchable knowledge base, updated firmware releases, latest product documentation, service request ticket generation and trouble-shooting tools. All of this, and more, is available in the *Support* section of the ADTRAN website at <http://www.adtran.com>.

When needed, further post-sales assistance is available by calling our Technical Support Center. Please have your unit serial number available when you call.

Technical Support	(888) 4ADTRAN
International Technical Support	1-256-963-8716

Installation and Maintenance Support

The ADTRAN Custom Extended Services (ACES) program offers multiple types and levels of installation and maintenance services which allow you to choose the kind of assistance you need. This support is available at:

<http://www.adtran.com/aces>

For questions, call the ACES Help Desk.

ACES Help Desk	(888) 874-ACES (2237)
----------------	-----------------------

Training

The Enterprise Network (EN) Technical Training Department offers training on our most popular products. These courses include overviews on product features and functions while covering applications of ADTRAN's product lines. ADTRAN provides a variety of training options, including customized training and courses taught at our facilities or at your site. For more information about training, please contact your Territory Manager or the Enterprise Training Coordinator.

Training Phone	(800) 615-1176, ext. 7500
Training Fax	(256) 963-6700
Training Email	training@adtran.com

Table of Contents

Introduction to the NetVanta Solution	17
Features and Specifications	18
Unpack and Inspect the System	19
Contents of ADTRAN Shipments	19
Physical Description	20
Reviewing the Base Unit Front Panel Design	20
Front Panel LEDs	20
Reviewing the Rear Panel Design	21
Rear Panel Interfaces	21
Unit Installation	22
Installing the Antennas	22
Mounting Options	22
Wall Mounting	23
Getting Started	24
Supplying Power to the NetVanta 150 Unit	24
Connect to the NetVanta 150 Unit	24
Factory Default Switch	24
Appendix A. Connector Pin Definitions	25
Index	27

List of Figures

Figure 1.	NetVanta 150 Front Panel Layout	20
Figure 2.	NetVanta 150 Rear Panel Layout	21
Figure 3.	Wall Mounting the NetVanta 150 Unit	23

List of Tables

Table 1.	NetVanta 150 Unit LEDs	20
Table A-1.	10/100BaseT Ethernet Port Pinouts	25

1. INTRODUCTION TO THE NETVANTA SOLUTION

The NetVanta 150 is a standalone wireless access point (WAP) designed for use by enterprise customers in the small to medium enterprise (SME) market space. The primary application is to provide a secure gateway for wireless clients to connect to the wired network provided by NetVanta switch and router products. The NetVanta 150 can operate as a wireless bridge for Local Area Networks (LAN) and as a repeater to extend the range of the wireless network. This unit offers the following features:

- Power from a POE enabled RJ45 Ethernet connection or from an ADTRAN external 12 V DC converter supply.
- Supports IEEE802.11a, 802.11b, and 802.11g wireless access. It supports concurrent 802.11a and 802.11b/g connections.
- Two dual-band antennas are included as standard equipment.
- A single 10/100 Base-T Ethernet port for connection to the NetVanta switch/router product.
- Two integral RP-SMA connectors provide connection for standard dual-band antennas.
- Four LEDs provide status information and WAN/LAN activity information.
- Reset switch for restoring default configuration.

The NetVanta 150 user configuration and management are provided through the connected NetVanta switch/router.

Features and Specifications

The following list highlights the major features of the NetVanta 150 unit.

- IEEE 802.11a Wireless
- IEEE 802.11b/g Wireless
- Concurrent 802.11a and 802.11 b/g connections
- Two rear-panel dual-band RP-SMA detachable antennas
- One 10/100 Base T Ethernet interface
- 802.3af POE support
- WEP/WPA/WPA2 Wireless Security
- Four front-panel LED indicators
- One rear-panel Reset switch
- Supports 802.11h
- Supports 802.11j
- Supports draft IEEE 802.11e WMM QoS
- WMM Wi-Fi certified
- Hardware encryption support for the Wi-Fi Protected Access (WPA) and IEEE 802.11i security specifications provides Advanced Encryption Standard (AES), Temporal Key Integrity Protocol (TKIP) and WEP without performance degradation
- For product available in USA & Canada, only channel 1-11 can be operated of 2412-2462 MHz & will be limited to transmit in 5180 - 5240 MHz only by firmware control.
- Frequency Range:
 - IEEE 802.11a: 5.150~5.350 GHz
 - 5.745~5.825GHz
 - Turbo mode: 5.760GHz/ 5.800GHz
 - IEEE 802.11b/g : 2.412~2.462 GHz
 - IEEE 802.11g Turbo : 2.437 GHz
- Dynamic Frequency Selection/Transmit Power Control (DFS/TPC) for international operation
- Environmental
- Operating Temperature: 32°F to 122°F (0°C to 50°C)
- Storage/Transport Temperature: 68°F to 185°F (20°C to 85°C)
- Humidity: Up to 95% non-condensing

□ This hardware installation guide describes the NetVanta 150, details basic functionality, gives installation □ instructions, and lists unit specifications. For more information on router configuration for a specific □ application, refer to the quick configuration documents provided on the ADTRAN website at □ www.adtran.com. For details on the command line interface, refer to the Command Reference Guide, also □ on the website. □

Unpack and Inspect the System

The NetVanta 150 unit is shipped in its own cardboard shipping carton. Open the carton carefully, and avoid slicing too deeply into the carton with sharp objects.

After unpacking the unit, inspect it for possible shipping damage. If the equipment has been damaged in transit, immediately file a claim with the carrier and contact ADTRAN Customer Service (see *Repair and Return* on page 9).

Contents of ADTRAN Shipments

Shipment of the NetVanta 150 unit includes the following items:

- NetVanta 150 Base Unit
- NetVanta 150 *Quick Start Guide*
- NetVanta 150 Ethernet cable (yellow)

2. PHYSICAL DESCRIPTION

Reviewing the Base Unit Front Panel Design

Figure 1 shows the NetVanta 150 front panel.

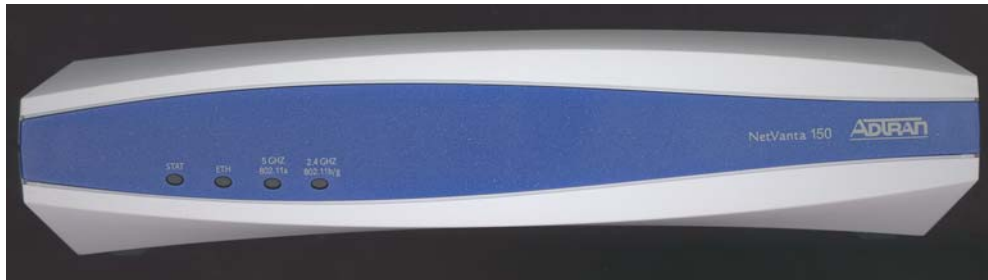

Figure 1. NetVanta 150 Front Panel Layout

Front Panel LEDs

The NetVanta 150 unit utilizes four LED indicators on the front panel. A single bi-color LED for the **STAT** condition and three single color LEDs for the **ETH**, **5GHz/802.11a** and **2.4GHz/802.11b/g** conditions. Table 1 describes these LEDs.

Table 1. NetVanta 150 Unit LEDs

LED	Activity	Indication
STAT	Green (flashing)	Unit is powering up. On power-up the STAT LED flashes until unit is ready for service. The STAT LED also flashes during firmware upgrade.
	Green (solid)	Power is on.
	Red (solid)	An error condition is present on the unit.
ETH	Green (flashing)	LAN activity is present (traffic in either direction).
	Green (solid)	Powered device is connected to the Ethernet port (i.e., link integrity).
	Off	There is no LAN activity on the Ethernet port (or unit is powered off).
5GHz/802.11a	Off	There is no 802.11a Wireless activity is detected.
	Green (flashing)	Data is being transmitted or received via the 802.11a Wireless band. Data includes network traffic as well as user data.
2.4GHz/802.11b/g	Off	There is no 802.11g or 802.11b Wireless activity is detected.
	Green (flashing)	Data is being transmitted or received via the 802.11b/g Wireless band. Data includes network traffic as well as user data.

Reviewing the Rear Panel Design

Figure 2 shows the NetVanta 150 rear panel. The unit accommodates a 12 VDC power supply.

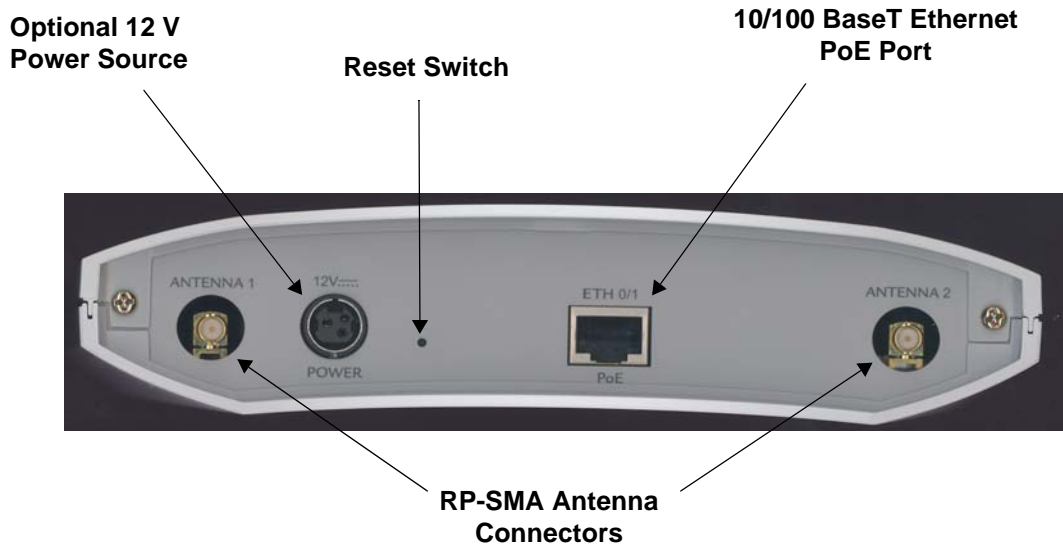

Figure 2. NetVanta 150 Rear Panel Layout

Rear Panel Interfaces

10/100BaseT Ethernet Interface

The **ETH 0/1** port on the NetVanta 150 is an RJ-45 connector with Power over Ethernet capability. See Table A-1 on page 25 for the Ethernet port pinouts. The Ethernet port provides the following:

- 10BaseT or 100BaseT with a single connector
- Auto-negotiation
- CSMA/CD
- IEEE 802.3 compatibility
- Auto MDI/MDIX

3. UNIT INSTALLATION

The instructions and guidelines provided in this section cover hardware installation topics such as wall mounting and supplying power to the unit.

WARNING

To prevent electrical shock, do not install equipment in a wet location or during a lightning storm.



Maximum recommended ambient operating temperature is 50°C.

Installing the Antennas

The NetVanta 150 unit ships with two dual-band RP-SMA detachable antennas. These must be installed before wall mounting the unit.

Instructions for Attaching the Antennas	
Step	Action
1	Place either of the two antennas directly onto the antenna port on the rear panel labeled Antenna 1 . See Figure 2 on page 21 to locate the ports on the rear panel.
2	Twist the antenna onto the threads until it is secure.
3	Repeat step 2 with the second antenna, attaching it to the Antenna 2 port.
4	Once both antennas are secured, the antennas may be flexed at the joint to increase reception.

Mounting Options

The NetVanta 150 unit can be installed in a wallmount or tabletop configuration. The following section provides step-by-step instructions for wall mounting.

Wall Mounting

Instructions for Wall Mounting	
Step	Action
1	Decide on a location for the NetVanta 150 unit. Keep in mind that the unit needs to be mounted at or below eye-level so that the LEDs are viewable.
2	Prepare the mounting surface by attaching a board (typically plywood, 3/4-inch to 1-inch thick) to a wall stud. Important! Mounting to a stud ensures stability. Using sheetrock anchors may not provide sufficient long-term stability.
3	Install two #8 PAN headscrews (1 1/2-inch or greater in length) wood screws into the mounted board, following these guidelines and referring to Figure 3: <ul style="list-style-type: none"> • Screws should be spaced horizontally, approximately 5 inches apart. Find exact positioning by using the location of the two keyed insets on the bottom of the NetVanta 300 Series unit as a guide. • Screws should be horizontally level with each other. • Leave approximately 1/4 inch of the screws protruding from the board to allow the heads of the screws to slide into place in the unit's keyed insets.
4	Slide the keyed insets on the bottom of the unit's chassis securely onto the screws.
5	Proceed to the steps given in <i>Getting Started</i> on page 24.

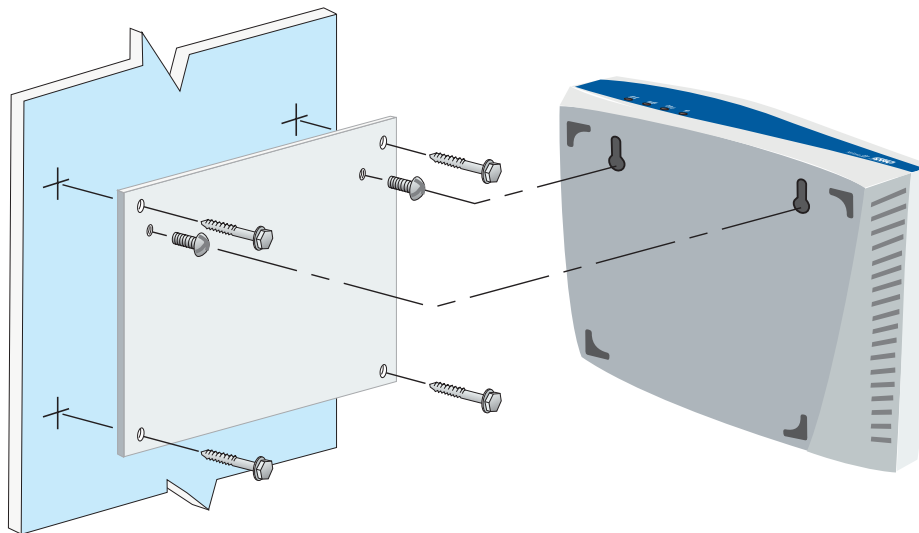

Figure 3. Wall Mounting the NetVanta 150 Unit

Getting Started



The 10/100BaseT Ethernet interface **MUST NOT** be metallically connected to interfaces which connect to the Outside Plant or its wiring. This interface is designed for use as an intrabuilding interface only. The addition of primary protectors is not sufficient protection to connect this interface metallically to OSP wiring.

Supplying Power to the NetVanta 150 Unit

The NetVanta 150 unit can be powered either by the LAN Ethernet connection or through the 12 VDC external supply. The Wall Supply is not included in shipment of this unit but can be requested from Adtran or your reseller. See *Product Support Information* on page 9 for more information on contacting Adtran.

Connect to the NetVanta 150 Unit

1. Connect the NetVanta 150 unit to the PC using the **ETH** port on the back of the unit and the appropriate Ethernet cable.
2. Supply power to the PC and the NetVanta 150 unit and begin the operating system boot up process. During boot up, the PC will obtain an IP address from the NetVanta 150 unit DHCP server. By default, both the DHCP and HTTP servers are enabled. The default IP address is 10.10.10.1.
3. Enter the unit's IP address in your browser address line. The default IP address is **10.10.10.1**.
4. You will then be prompted for the username and password (the default settings are **admin** and **password**).
5. The initial GUI screen appears.
6. Click on **Getting Started** in the **System** menu on the left side of your screen and follow the on-line instructions.



For security purposes, you should set up an **admin** password immediately. Use the **Passwords** page of the Web GUI to change this password.

Factory Default Switch

- If the factory default switch is pressed during bootup, the unit will stay in bootstrap mode. Since the unit has no serial port, Telnet has been built into the boot code. The default IP address is 10.10.10.1.



The default switch must be pressed **WHILE** the power light is flashing green. Do not press the default switch **BEFORE** the power light is flashing green, as this will cause boot to be missed.

- If the factory default switch is pressed and held for 5 seconds after boot, the **ETH** interface on the NetVanta 150 will default to 10.10.10.1 and all access policies will be removed from that interface.
- If the factory default switch is pressed for 30 seconds, a default configuration will overwrite your existing configuration and reboot the unit.

APPENDIX A. CONNECTOR PIN DEFINITIONS

The following table provides the pin assignments for the NetVanta 150.

Table A-1. 10/100BaseT Ethernet Port Pinouts

Pin	Name	Description
1	TX1	Transmit Positive
2	TX2	Transmit Negative
3	RX1	Receive Positive
4, 5	—	Unused
6	RX2	Receive Negative
7, 8	—	Unused

"This device has been designed to operate with the antennas listed below, and having a maximum gain of 802.11a 3dBi and 802.11b/g 2dBi. Antennas not included in this list or having a gain greater than the designed Antennas is strictly prohibited for use with this device. The required antenna impedance is 50 ohms."

Antenna Gain: IEEE 802.11a: 3dBi
IEEE 802.11b/g: 2dBi

Antenna Designation: Omni-directional Antenna

"To reduce potential radio interference to other users, the antenna type and its gain should be so chosen that the equivalent isotropically radiated power (e.i.r.p.) is not more than that permitted for successful communication."

- . that the device for the band 5150-5250 MHz is only for indoor usage to reduce potential for harmful interference to co-channel mobile satellite systems;
- . the maximum antenna gain permitted (for devices in the 5250-5350 MHz band) to comply with the e.i.r.p. limit; and
- . the maximum antenna gain permitted (for devices in the 5725-5825 MHz band) to comply with the e.i.r.p. limits specified for point-to-point and non point-to-point operation as appropriate, as stated in section A9.2(3).

In addition, users should also be cautioned to take note that high power radars are allocated as primary users (meaning they have priority) of 5250-5350 MHz and 5650-5850 MHz and these radars could cause interference and/or damage to LE-LAN devices.

Index

Numerics

10/100BaseT Ethernet interface 21
pinouts 25

A

admin password 24
antennas 22

B

boot up 24

C

connecting to unit 24
contents of shipment 19
customer service 9

D

default switch 24

E

Ethernet interfaces
LEDs 21
pinouts 25

F

factory default switch 24
features 18
front panel 20

G

getting started 24

I

installation 22
installing unit 22
interfaces 21

L

LEDs 20

M

mounting options 22

P

passwords page 24
physical description 20
pinouts
10/100BaseT 25
power over ethernet 24
product registration 9

R

rear panel 21

S

shipping contents 19
specifications 18

U

unpacking and inspecting the system 19

W

wall mounting 23
warranty 9
web GUI
passwords page 24

