

A

Instruction Manual

The following pages contain a preliminary copy of the User's Manual for the TRACER. ADTRAN, Inc. respectfully requests that this information be withheld from public inspection.



TRACER[®] 2xT1

User's Manual

RADIO FREQUENCY INTERFACE STATEMENT

This equipment has been tested and found to comply with the limits for an intentional radiator, pursuant to Part 15, Subpart C of the FCC Rules. This equipment generates, uses, and can radiate radio frequency energy. If not installed and used in accordance with the instructions, it may cause interference to radio communications.

The limits are designed to provide reasonable protection against such interference in a residential situation. However, there is no guarantee that interference will not occur in a particular installation. If this equipment does cause interference to radio or television reception, which can be determined by turning the equipment on and off, the user is encouraged to try to correct the interference by one or more of the following measures:

- Reorient or relocate the receiving antenna of the affected radio or television.
- Increase the separation between the equipment and the affected receiver.
- Connect the equipment and the affected receiver to power outlets on separate circuits.
- Consult the dealer or an experienced radio/TV technician for help.

W A R N I N G

Changes or modifications not expressly approved by ADTRAN could void the user's authority to operate the equipment.

Shielded Cables

A shielded-type power cord is required in order to meet FCC emission limits and also to prevent interference with nearby radio and television reception when using the AC voltage adapter. It is essential that only the Adtran-provided power cord be used.

FCC Output Power Restrictions

The FCC does not require licensing to implement this device. However, the FCC has established restrictions regarding maximum output power and the adjustments required when employing directional gain antennas. (Refer to "Setting the Transmitter Power" in Section 2 of this manual). These restrictions are detailed in FCC Part 15.247 (b)(1), (b)(3)(i), and (3)(iii). It is the responsibility of the individuals designing and implementing the radio system to assure compliance with these and any other pertinent FCC Rules and Regulations. **This device must be professionally installed.**

Exposure to Radio Frequency Fields

The TRACER is designed in three versions with the following power options:

2.4 GHz @ 100 mw

2.4 GHz @ 1 w

5.8 GHz @ 100 mw

These levels of RF energy are below the Maximum Permissible Exposure (MPE) levels specified in FCC OET 65:97-01. The installation of high gain antenna equipment in the system configuration may create the opportunity for exposure to levels higher than recommended for the general population at a distance less than one meter from the center of the antenna. **The following precautions must be taken during installation of this equipment:**

Radio Frequency Interference Statement

- The installed antenna must not be located in a manner that allows exposure of the general population to the direct beam path of the antenna at a distance less than one meter. Installation on towers, masts, or rooftops not accessible to the general population is recommended; or
- Mount the antenna in a manner that prevents any personnel from entering the area within one meter from the front of the antenna.
- It is recommended that the installer place radio frequency hazard warnings signs on the barrier that prevents access to the antenna.
- Prior to installing the antenna to the RFC output, make sure the power is adjusted to the settings specified in section 2 of this manual.
- During antenna installation, be sure that power to the TRACER equipment is turned *off* in order to prevent any energy presence on the coaxial connector.
- During installation and alignment of the antenna, do not stand in front of the antenna assembly.
- During installation and alignment of the antenna, do not handle or touch the front of the antenna.

These simple precautions must be taken to prevent general population and installation personnel from exposure to RF energy in excess of specified MPE levels.

	Page
Section 1 TRACER Description	
Introduction	1
ISM Band Spread Spectrum	1
NEBS	1
Applications	2
Spread Spectrum	2
Direct Sequence	2
Coding	2
Channel Selection	3
Forward Error Correction	3
T1 Operation	3
Framing	3
Line Code	4
DS1/DSX-1 Interface	4
Line Buildout or LBO	4
TRACER System Configuration	4
Baseband Processor or BBP	4
DS1/DSX-1 Interface	5
VT-100 RS-232 Interface	6
Alarm Contacts	6
IF Signal	6
Power	6
Controls and Indicators	6
Non-Volatile Memory	8
Built-In Tests	8
Radio Frequency Convertor or RFC	8
Antenna	10

Table of Contents

Section 2 Installation

Radio Frequency Interference Statement	11
Shielded Cables	11
FCC Output Power Restrictions	11
Exposure to Radio Frequency Fields	11
Unpack, Inspect	12
Rackmounted RFC Configuration	12
Mastmounted RFC Configuration	12
Installation	13
Location and Mounting	13
Power Requirements	13
Grounding	13
DS1/DSX-1 Interface	14
Link Planning	15
Antenna Feedline Loss	15
Antenna Gain	15
Path Loss	16
Path Availability	16
Setting the Transmitter Power	17
2.4 GHz, 1 Watt Transmitter Option	17
Setting the RFC Frequency Plan on Non 1 Watt 2.4 GHz Models	18
Setting the RFC Frequency Plan on 5.8 GHz Models	19
Directions for Changing the Frequency Plan on the Rack Mount RFC	20
Directions for Changing the Frequency Plan on the Mast Mount RFC	20
Connecting the BBP and the RFC	20
Applying Power	20
Automatic BBP Frequency Plan	20
Spreading Code	21

Co-Locating Multiple Systems	21
Antenna Alignment	21
RF Low	22
Remote BERT	22
Alarm Contacts	22
Section 3 Operation	
VT-100 User Interface	23
RS-232 Interface	23
Modem Connection	23
Telemetry Byte Oriented Serial Interface	23
RF Down System Status	28
Cable Connections	28
Password	28
Main Menu Selections	29
System Status Page	29
Main Menu Page	30
T1 Status Page	30
Link Performance History	31
Channel A Statistics Page	31
Channel B Statistics Page	32
Alarm Page	32
Test Menu	33
Configuration Menu	34
Remote Access	35
Section 4 Troubleshooting	
General	37
Problem Descriptions and Recommended Actions	37

Table of Contents

Troubleshooting using the front panel indicators	37
“Link Error” light is lit, or link is down	37
“BPV” light on T1-A or B is lit	38
RED light on T1-A or B is lit	38
“LBK-A” or “LBK-B” is lit.....	39
“AIS/YEL” on T1-A or T1-B is lit	39
“AIS/YEL” indicator is flashing.....	40
No “Power” light	40
“Test” light is lit or blinking	41
“TST” light is lit after pressing “Remote Test” button	41
“Fail” light is lit after pressing “Remote Test” button	42
“RF Low” light is on	42
Troubleshooting Using the VT-100 User Interface	43
RED Alarm	43
BLV Alarm	43
YEL/AIS Alarm.....	44
RF Link Alarm or Code Sync Alarm	44
Carrier Sync Alarm or T1 Mux Framing Alarm.....	45
ES Values in T1 Status Menu	46
SES Values in History Menu.....	46
Section 5 Specifications	
Transmitter	47
Receiver	47
Frequency Plan	47
Spread Spectrum Data Pump	47
Interface Specifications	47
User Interface	47
VT-100 Terminal Interface.....	48

Mechanical & Environmental	48
Power	48
 Section 6 Warranty, Ordering and Return Information	
Warranty	49
Sales	49
Repairs and Returns	49
Technical Support	49
 Glossary	
Acronyms Used in This Manual	51
 Appendix A Cable Connections	
Terminal Connection (DB25)	A-1
Personal Computer Connection (DB9)	A-1
Modem Connection (DB25)	A-2

Table of Contents

Illustrations

1-1.	Typical Application	2
1-2.	Bandwidth Division	3
1-3.	BBP	4
1-4.	BBP Rear Panel	5
1-5.	BBP Block Diagram	5
1-6.	BBP Front Panel (with door closed)	6
1-7.	BBP Front Panel (with door open)	7
1-8.	RFC Module	9
1-9.	RFC Function Block Diagram	9
1-10.	Mastmount RFC Housing	10
1-11.	Rackmount RFC Housing	10
2-1.	2.4 GHz Diplexer	18
2-2.	5.8 GHz Diplexer	19
3-1.	Rear Panel Connectors	24
3-2.	System Status Page	28
3-3.	System Status Page	29
3-4.	Main Menu Page	30
3-5.	T1 Status Page	30
3-6.	Link Performance History Page	31
3-7.	Channel A Statistics Page	31
3-8.	Channel B Statistics Page	32
3-9.	Alarm Page	32
3-10.	Test Menu	33
3-11.	T1 Loopback Locations	33
3-12.	Configuration Menu	34
3-13.	Remote Current System Status	35

SECTION 1 TRACER DESCRIPTION

INTRODUCTION

The TRACER provides dual T1 transport by way of a spread spectrum microwave link for distances up to 30 miles or more depending on path engineering. System performance is determined, in part, by the engineering of the microwave link. Each end of a TRACER link is composed of two units -- the baseband processor (BBP) and the radio frequency converter (RFC). Two DS1/DSX-1 (T1) interfaces are provided on the rear of the BBP, which can be mounted in a 19-inch rack. The DS1/DSX-1 interface provides connections up to 6000 feet from T1 equipment. A single coaxial cable connects the BBP to the RFC and another connects the RFC to the antenna.

ISM BAND SPREAD SPECTRUM

The Federal Communications Commission (FCC) has established several portions of the radio frequency (RF) spectrum for use in Industrial, Scientific, and Medical (ISM) applications. Part 15.247 of the FCC rules describes the requirements of systems that operate in these bands. The three bands set aside, 902-928 MHz, 2400-2483.5 MHz, and 5725-5850 MHz, are designated for use by spread spectrum transmitters, either frequency hopping or direct sequence. The TRACER operates in the 2400 to 2483.5 MHz or 5725-5850 MHz band using direct sequence spread spectrum (DSSS) transmission.

NEBS

Network Equipment Building Standards (NEBS) defines a rigid and extensive set of performance, quality, environmental and safety requirements developed by Telcordia, the R&D and standards organization owned by the seven regional Bell operating companies (RBOCs). NEBS compliance is often required by telecommunications service providers such as BOCs (Bell Operating Companies) and Interexchange Carriers (IEC) for equipment installed in their switching offices. NEBS defines everything from fire spread and extinguish ability test to Zone-4 earthquake tests, thermal shock, cyclic temperature, mechanical shock, and electro-static discharge. TRACER is NEBS Level 3 compliant (see **Table 1-1** for a list of testing requirements.)

Table 1-1. NEBS Testing Requirement

Document	Description
GR-63 Operational Thermal (Short Term Conditions)	R4-6/72 Equip. should withstand exposure to "Table 4-4 Short T" R4-7/73 Equip should withstand exposure to "Table 4-5 Short T"
Storage Environments and Transportation and Handling	R4-3 - R4-5/69-70 Exposure to tests in Tables 4-2, 4-3 R4-41- R4-43/107-109 Packaged and Unpackaged shock criteria R4-58/124 Transportation vibration criteria
Earthquake (Zone 4 Level)	R4-44 - R4-46/110-112 Equipment and Frame Level testing of Section 5.4.1 R4-48/114 Functional requirements testing of Section 5.4.1 O4-49/115 Constructed to meet testing of Section 5.4.1 R4-51/117 Base mounting to floor without auxiliary support R4-53/119 Specs for concrete anchors
Airborne Contaminants (Outdoor Levels)	O4-60/126 Equipment should withstand testing "Table 4-10" R4-61/127 Equipment should withstand testing "Table 4-10" and o.s.air
GR-1089 ESD (Installation and Repair)	O2-4/4 Perform under tests of IEC 801-2, Clause 5
EMI Emissions (Open Doors)	O3-2/9 EMI Emissions (Open Doors)
EMI Immunity (Open Doors)	CR3-11/18 Radiated Performance Criteria R3-10/17 Radiated Immunity Criteria
Steady State Power Induction Conditional Requirements	CR5-2/43 Signaling - test to Table 5-1 (>20 ft) CR5-4/45 C-Message -Signaling-test to test condition (>20 ft) CR5-9/50 Signaling - test to Table 5-3 (>20 ft) CR5-11/52 C-Message weighted metallic noise test (>20 ft)

Section 1 TRACER Description

APPLICATIONS

Any application that would typically use metallic T1 as a transport can use the TRACER instead. **Figure 1-1** illustrates a typical application.

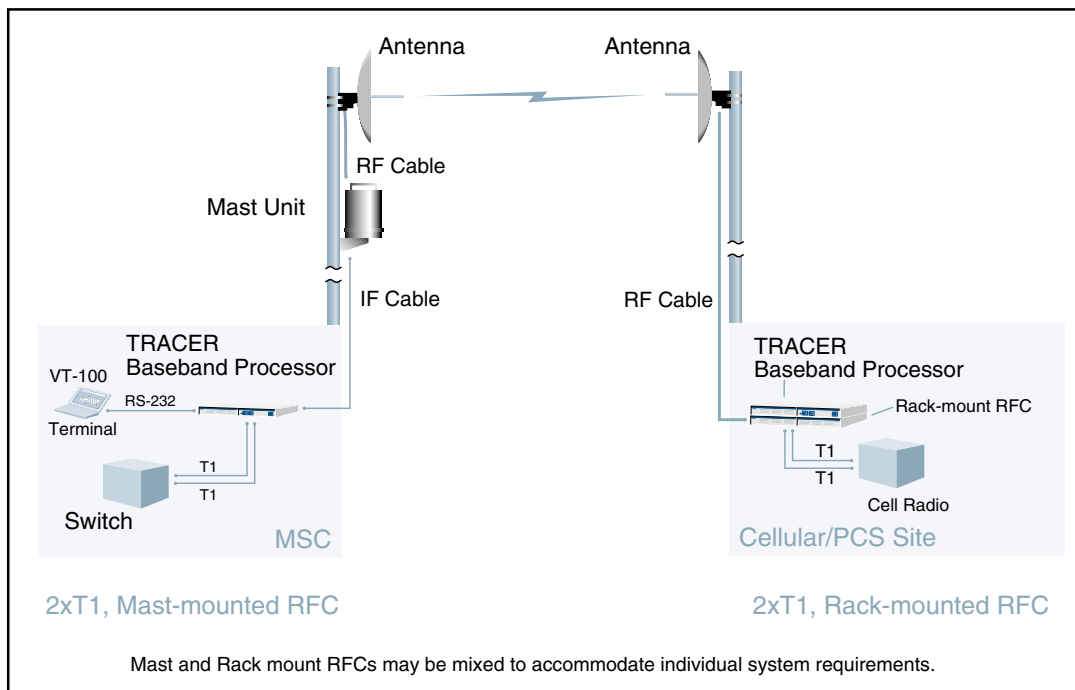

Figure 1-1. Typical Application

The TRACER can be used in any application requiring that data be shared at a high rate of speed. In addition to telephony applications, TRACER can be used in data communications such as inter-networking, video conferencing, and telemetry.

SPREAD SPECTRUM

Spread spectrum is a form of communication in which the bandwidth of a message signal is intentionally increased or “spread.” The FCC rules allow two methods of spreading – frequency hopping and direct sequence. TRACER employs direct sequence spread spectrum.

Direct Sequence

A direct sequence transmitter spreads the signal by mixing the data with the output of a pseudorandom number generator which changes state at a rate higher than the data rate. This rate is called the “chipping” rate. The TRACER chipping rate is twelve times the data rate.

Coding

Many different pseudorandom sequences exist. The sequences are called pseudorandom because, although they appear noise-like, they are determinant and repeat after a specific number of chips. The longer a code is, the better correlation characteristics it possesses. These traits allow multiple spread

Section 1 TRACER Description

spectrum systems to operate in the presence of one another with minimal interference if they are operating with different sequences. The TRACER allows the selection of one of ten different 120-bit long sequences.

CHANNEL SELECTION

The FCC has allocated 83.5 MHz of spectrum in the 2.4 GHz band and 125 MHz in the 5.8 GHz band in which TRACER operates. A TRACER system fully uses the available bandwidth – transmitting in one half and receiving in the other. **Figure 1-2** illustrates the bandwidth division.

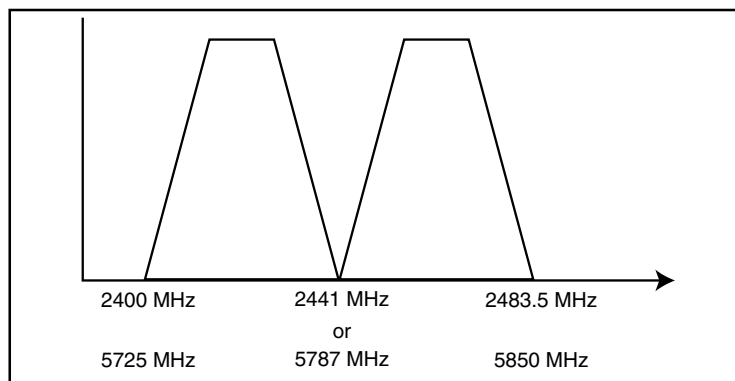

Figure 1-2. Bandwidth Division

The transmitter at one end (TxA) of a link will transmit in the lower half of the spectrum. Consequently the receiver at the other end will receive in the lower half of the band and transmit in the upper half. Thus, a system will operate in one of two frequency plans – transmit in the upper and receive in the lower or vice versa. These two plans are called Plan A and Plan B. One end of a path will be on Plan A and the other will be on Plan B. Shipment of a link will consist of an A and a B unless otherwise specified.

FORWARD ERROR CORRECTION

With the addition of overhead data, error detection and correction capability can be added to a data stream. Error correction can be accomplished by allowing the receiver to request the re-transmission of an errored block once detected. The TRACER, on the other hand, implements forward error correction (FEC) which adds enough overhead data for the receiver to detect and correct errors in the data stream. This capability comes at the cost of bandwidth. The addition of FEC decreases the required signal-to-noise (S/N) ratio by approximately 5.5 dB to achieve a given bit error rate (BER).

T1 Operation

Framing

The data in a T1 stream is delimited by framing bits. The pattern of the framing bits follows one of two formats -- extended superframe (ESF) or superframe (SF). The T1 interface must be prepared for the format that will be used.

Section 1 TRACER Description

Line Code

A mark in the data stream is coded as a pulse on the T1 line. A space is coded as “no activity” on the T1 line. As a form of error detection, subsequent marks in the data stream are coded as pulses of alternating polarity, either positive going or negative going. This type of line coding is called alternate mark inversion (AMI).

For the T1 receiver to operate correctly, a minimum number of “1s” must exist on the T1 facility. If the data cannot be guaranteed to meet this requirement, then another line coding format is used. In the bipolar 8 zero substitution (B8ZS) scheme, a string of eight “0s” is replaced by a special sequence of eight bits that contains a bipolar violation. The receiver, upon recognizing this sequence, reinserts the eight “0s” and the data is recovered intact.

DS1/DSX-1 Interface

When connecting the interface to the public switched network, an ADTRAN-provided cross-over cable (part number 3125M011@A) is required to meet FCC part 68 and IC CS03 requirements. This cable is required to cross-over the Tx and Rx pairs to meet the connecting arrangement of a network interface device. This cable is included with the BBP and is labelled “T1 Crossover.”

Line Buildout or LBO

The DS1/DSX-1 interface provides two different types of line buildouts (LBOs), respectively. When set for DS1, LBOs for 0 dB, -7.5 dB, -15 dB, and -22 dB are available. The DS1 interface can operate on line lengths up to 6,000 feet. When set for DSX-1 interface, LBOs for 0-133 feet, 266-399 feet, 399-533 feet, and 533-655 feet are available.

TRACER SYSTEM CONFIGURATION

A TRACER system is composed of three major subsystems -- a baseband processor, a radio frequency convertor, and an antenna. The following section describes the system components.

Baseband Processor or BBP

The BBP (ADTRAN part number 1280003L2) is a 1-U, 19-inch rackmountable unit that provides the system electrical interfaces, user controls and indicators, and performs the spread spectrum processing for the system. The rear panel provides all of the electrical interface points -- DS1/DSX-1 interface, DS1/DSX-1 monitor, VT-100 terminal, alarm contacts, IF signal, DC power (from facility), and power (from AC adapter). The BBP and its rear panel are illustrated in **Figure 1-3 and 1-4**.

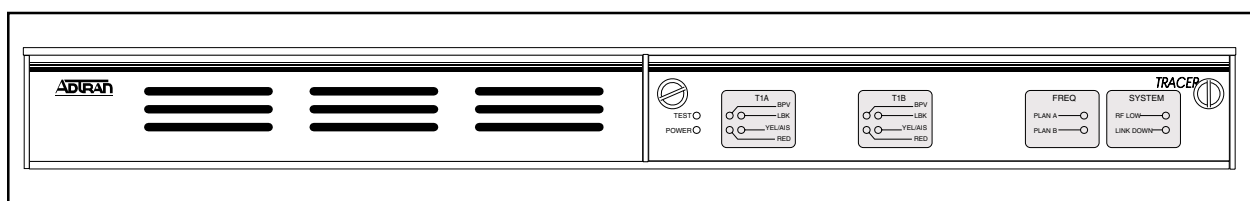

Figure 1-3. BBP

Section 1 TRACER Description

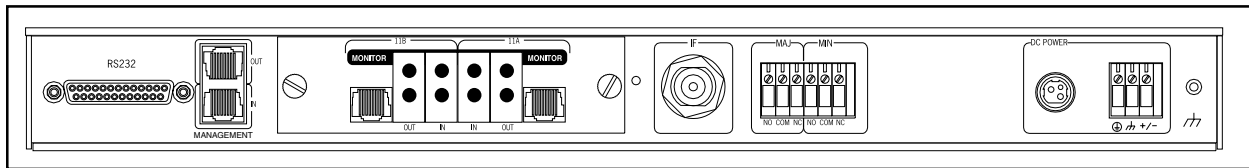

Figure 1-4. BBP Rear Panel

DS1/DSX-1 Interface

Two DS1/DSX-1 interfaces, labelled “T1A” and “T1B,” are provided for connecting to the T1 equipment. Two types of physical interfaces are provided -- RJ-48C and bantam jacks.

The interfaces are illustrated in **Figure 1-5**, BBP Block Diagram. The functions of the BBP are partitioned into three printed circuit boards or PCBs, all contained in the same enclosure.

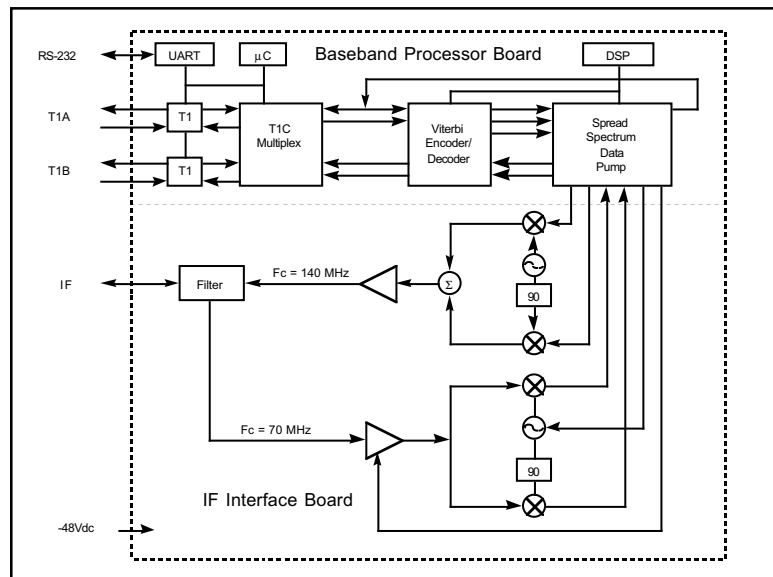

Figure 1-5. BBP Block Diagram

The DS1/DSX-1 interfaces provided for each channel are the same. The upper bantam connectors, labeled “Monitor,” provide isolated monitor points for testing. The lower bantam jacks provide signal insertion points. The insertion of a bantam jack disconnects the RJ-48C connector from the circuit. The DS1/DSX-1 interface can operate on line lengths up to 6000 feet.

When connecting either T1 interface to the public switched network, an ADTRAN-provided cross-over cable (part number 3125M011@A) is required to meet FCC part 68 and IC CS03 requirements. This cable is included with the BBP and is labelled “T1 Crossover.” This cable is required to cross-over the TX and RX pairs to meet the connecting arrangement of a network interface device.

For connections to other CPE-type equipment, such as an ADTRAN TSU-100, a straight-through T1 cable is provided by ADTRAN (part number 3127004) and is included with the BBP.

Section 1 TRACER Description

VT-100 RS-232 Interface

A serial interface port using RS-232C signal levels is provided for attaching a VT-100-compatible terminal. The connection is made via a DB-25 connector on the rear panel. The data rate is configured for 9600 bps, 8 data bits, no parity, and 1 stop bit.

A 7-day error history of the T1 interfaces and radio link is also provided. Fifteen-minute histories are provided for the most recent 24 hours of operation.

Alarm Contacts

Two sets of alarm contacts are provided on the rear of the BBP: major alarm and minor alarm. A major alarm indicates the radio link is not operational. A minor alarm indicates that system performance is degraded or that the T1 interfaces are experiencing errors. Normally-open and Normally-closed contacts are provided for both alarm types. Under normal operating conditions there is no continuity between the Normally-open and Common contacts, and, under an alarm condition, continuity between those contacts exists. The Normally-closed and Common contacts normally have continuity, while under alarm conditions, these contacts are open.

IF Signal

The N-type connector on the rear panel provides the interface point between the BBP and the RFC. This connection provides the data signal, power, and configuration information to the RFC. A coaxial cable (ADTRAN part number 3125RF027@A) is provided for connecting the BBP to the RFC for the rackmount model. Cable for connecting the BBP to a mastmount RFC must be provided by the customer after the length of cable has been determined.

Power

The unit receives power via one of two connectors. Power for the entire system is provided by these interfaces. The three-pin circular DIN connector is provided to connect an optional ADTRAN desktop AC adapter (ADTRAN part number 1360DSK24VL1), providing 24 volts DC. The three-pin terminal block allows the connection of any DC power source providing between 21 and 60 volts DC. The power consumption of the entire system is 30 watts.

Controls and Indicators

The system may be configured via the front panel, which is accessible behind a drop-down panel on the right half of the BBP. The front panel is illustrated in **Figures 1-6 and 1-7**.

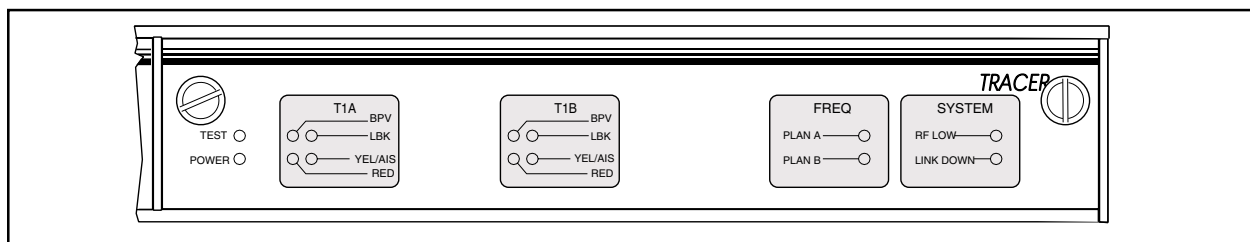

Figure 1-6. BBP Front Panel (with door closed)

Section 1 TRACER Description

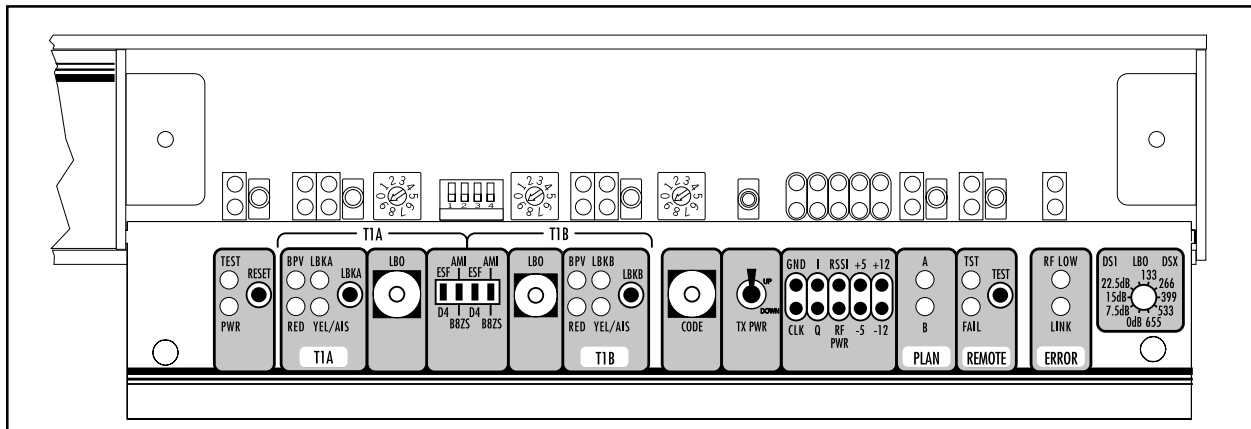

Figure 1-7. BBP Front Panel (with door open)

Options that are set from the front panel can be overridden via the terminal interface. As a rule, a *green* LED indicates a good situation, a *red* LED indicates an error situation, and a *yellow* LED indicates a configuration option. LEDs indicating overall system integrity are listed below.

Test Red indicates that the self-test has completed and failed
 PWR Green indicates that DC voltage is applied

The LEDs associated with the DS1/DSX-1 interfaces are listed below. There are two sections of identical indicators -- one for each DS1/DSX-1 interface.

BPV Red if the incoming T1 stream contains bipolar violations
 RED Red if there is no signal present at the T1 interface
 LPBK Yellow if the T1 interface is in loopback
 YEL/AIS Flashes to indicate a T1 Yellow Alarm; remains *On* (solid) to indicate an AIS alarm (when the DS1/DSX-1 is receiving a Blue code)

The LEDs indicating error conditions are listed below.

RF Low Red indicates the received RF carrier level is too low
 Link Down Radio path is down

The front panel controls are listed below.

Reset Reset the system
 LBKA Toggles the T1-A between no loopback and line loopback
 LBO Selects TI line buildout. Template on right edge of faceplate designates switch setting.
 LBKB Toggles the T1-B between no loopback and line loopback

Section 1 TRACER Description

Tx PWR	UP increments radio transmit power up. DOWN increments radio transmit power down. VT100 terminal will indicate Tx Power setting.
Remote Test	Initiate a remote test across the RF link

Non-volatile Memory

The TRACER system contains non-volatile memory to retain certain configuration settings. These settings include:

- Frequency plan
- Chipping code (if set from VT-100)
- Password
- Password enabling
- Site name
- T1 line coding (if set from VT-100)
- T1 framing (if set from VT-100)

Built-In Tests

The TRACER has several features to aid in site setup and later debugging. These diagnostics include T1 loopbacks and a link test with BERT (Bit Error Rate Test) data. A link test is performed by pressing the test button. The remote unit will then send a pseudorandom data pattern and the local end will compute a BER. After the conclusion of the test, the remote end will automatically be instructed to terminate the pattern generation. If any bit errors are introduced, the Remote Test Fail LED will illuminate.

The monitor points provided on the front panel of the system are listed on the next page.

I	Demodulated received baseband output
Q	Demodulated received baseband output
CLK	Recovered clock for observing EYE pattern
RSSI	DC voltage indicating strength of the received signal at the antenna
+5	System 5 volts
-5	System -5 volts
+12	System +12 volts
-12	System -12 volts
RF PWR	Voltage supplying RF power
GND	System ground

Radio Frequency Converter or RFC

The radio frequency converter (RFC) provides the radio frequency (RF) interface between the baseband processor and the antenna. The RFC is partitioned, functionally, into two major components - the transmitter and the receiver.

The major connections illustrated in **Figure 1-8** are transmit signal, receive signal, and the IF signal connection.

The RFC unit is enclosed in a metal enclosure approximately 9.5 inches x 5.5 inches x 1 inch and is mounted in a 1-U, 19-inch rackmountable housing or mastmountable, weatherproof enclosure.

Section 1 TRACER Description

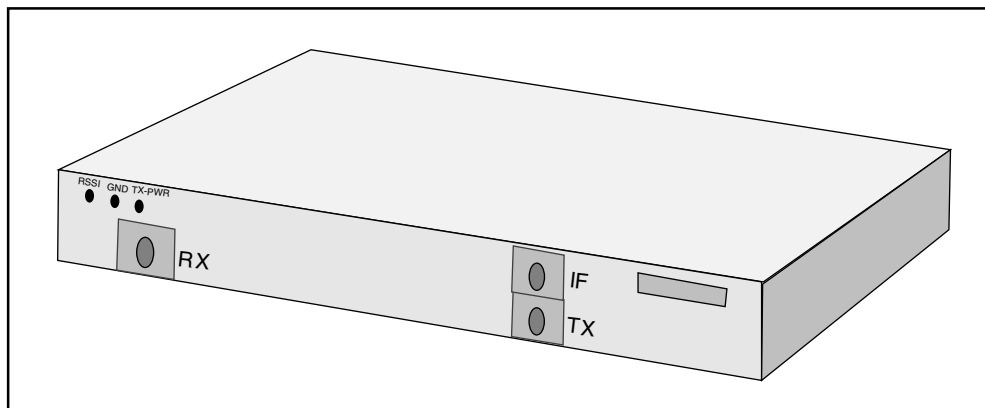

Figure 1-8. RFC Module

Three SMA connectors, located on the RFC module, provide RF and IF connection points. A test point is provided for monitoring the received signal strength indicator (RSSI). The voltage (relative to the GND test point) present on this test point represents the level of the received signal. This signal is used to align the antenna when installing the system and to verify the link is performing as designed. Another test point is provided to monitor the transmitter output power during system configuration. The only connections that must be made in the field are a coax connection between the baseband processor and the RFC and a coax connection between the RFC and the antenna. These connections require male, type N coax connectors.

The *IF* connector provides the connection between the baseband processor and the rackmounted or mastmounted RFC. (An 8-inch IF cable [ADTRAN part # 3125RF027@A] is provided for rackmount systems). The *TO ANTENNA* connection provides the connection between the RFC and the antenna. A block diagram of the RFC functions is shown in **Figure 1-9**.

The RFC module is enclosed in either a 19-inch EIA rackmount housing, or a weather-tight enclosure suitable for mastmounting near the antenna for enhanced system performance. The RFC mastmount and rackmount housings are illustrated in **Figures 1-10 and 1-11**.

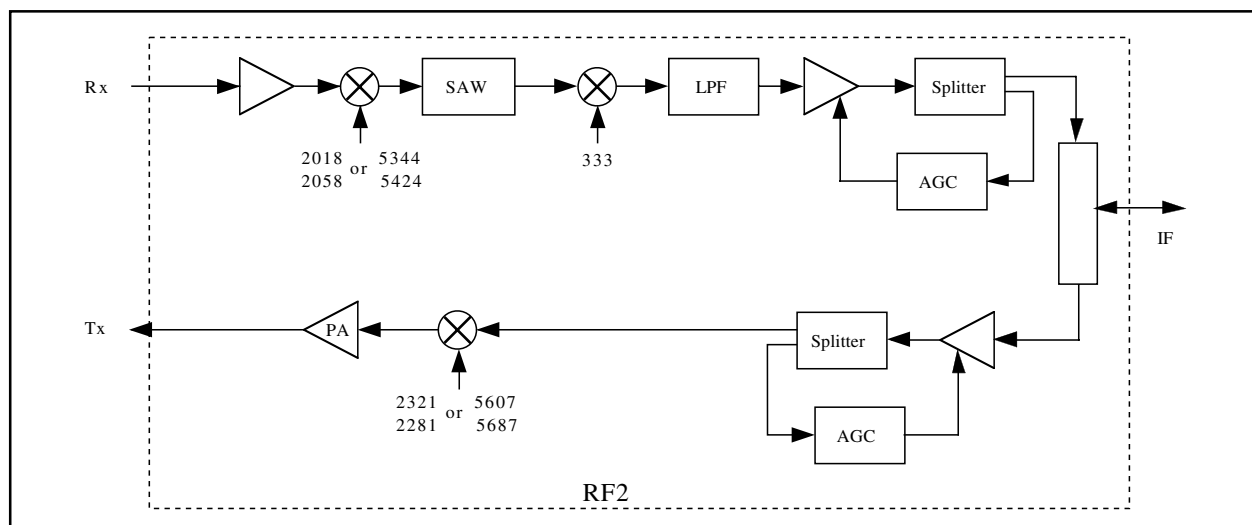

Figure 1-9. RFC Function Block Diagram

Section 1 TRACER Description

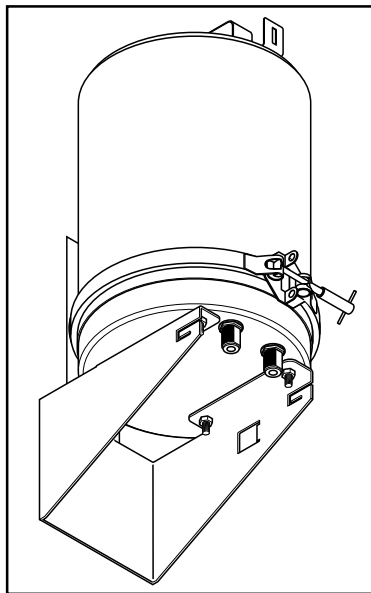

Figure 1-10. Mastmount RFC Housing

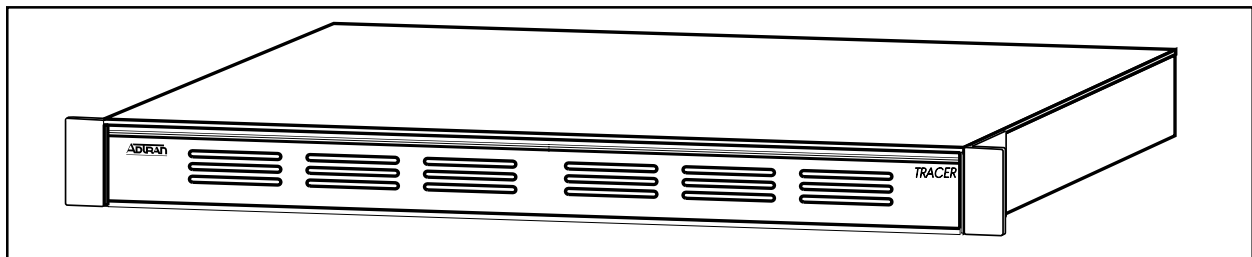

Figure 1-11. Rackmount RFC Housing

Antenna

TRACER is intended to be coupled with an antenna that is directional and provides signal gain. There are several reasons for this requirement:

- TRACER operates in point-to-point applications; therefore, an omnidirectional antenna is not needed.
- The FCC provides no recourse in this band in the event of nearby interference, so a highly directional antenna reduces the likelihood of interference in the antenna pattern.
- The low power transmitter is intended to be used with a high-gain antenna for long links.

The antenna requirements are listed below.

<u>Antenna</u>	<u>100 mw</u>	<u>1 w</u>
Minimum gain	15 dBi	6 dBi
Minimum return loss	15 dB	15 dB
Connector	N-type	N-type
Impedance	50Ω	50Ω

RADIO FREQUENCY INTERFERENCE STATEMENT

This equipment has been tested and found to comply with the limits for an intentional radiator, pursuant to Part 15, Subpart C of the FCC Rules. This equipment generates, uses, and can radiate radio frequency energy. If not installed and used in accordance with the instructions, it may cause interference to radio communications.

The limits are designed to provide reasonable protection against such interference in a residential situation. However, there is no guarantee that interference will not occur in a particular installation. If this equipment does cause interference to radio or television reception, which can be determined by turning the equipment on and off, the user is encouraged to try to correct the interference by one or more of the following measures:

- Reorient or relocate the receiving antenna of the affected radio or television.
- Increase the separation between the equipment and the affected receiver.
- Connect the equipment and the affected receiver to power outlets on separate circuits.
- Consult the dealer or an experienced radio/TV technician for help.

WARNING

Changes or modifications not expressly approved by ADTRAN could void the user's authority to operate the equipment.

SHIELDED CABLES

A shielded-type power cord is required in order to meet FCC emission limits and also to prevent interference with nearby radio and television reception when using the AC voltage adapter. It is essential that only the ADTRAN-provided power cord be used.

FCC OUTPUT POWER RESTRICTIONS

The FCC does not require licensing to implement this device. However, the FCC has established restrictions regarding maximum output power and the adjustments required when employing directional gain antennas. (Refer to "Setting the Transmitter Power" in Section 2 of this manual). These restrictions are detailed in FCC Part 15.247 (b)(1), (b)(3)(i), and (3)(iii). It is the responsibility of the individuals designing and implementing the radio system to assure compliance with these and any other pertinent FCC Rules and Regulations. **This device must be professionally installed.**

Exposure to Radio Frequency Fields

The TRACER is designed in three versions with the following power options:

- 2.4 GHz @ 100 mw
- 2.4 GHz @ 1 w
- 5.8 GHz @ 100 mw

These levels of RF energy are below the Maximum Permissible Exposure (MPE) levels specified in FCC OET 65:97-01. The installation of high gain antenna equipment in the system configuration may create the opportunity for exposure to levels higher than recommended for the general population at a distance less than one meter from the center of the antenna. **The following precautions must be taken during installation of this equipment:**

Section 2 Installation

- The installed antenna must not be located in a manner that allows exposure of the general population to the direct beam path of the antenna at a distance less than one meter. Installation on towers, masts, or rooftops not accessible to the general population is recommended; or
- Mount the antenna in a manner that prevents any personnel from entering the area within one meter from the front of the antenna.
- It is recommended that the installer place radio frequency hazard warnings signs on the barrier that prevents access to the antenna.
- Prior to installing the antenna to the RFC output, make sure the power is adjusted to the settings specified in section 2 of this manual.
- During antenna installation, be sure that power to the TRACER equipment is turned *off* in order to prevent any energy presence on the coaxial connector.
- During installation and alignment of the antenna, do not stand in front of the antenna assembly.
- During installation and alignment of the antenna, do not handle or touch the front of the antenna.

These simple precautions must be taken to prevent general population and installation personnel from exposure to RF energy in excess of specified MPE levels.

UNPACK, INSPECT

Carefully inspect the TRACER for any shipping damages. If damage is suspected, file a claim immediately with the carrier then contact ADTRAN Customer Service. If possible, keep the original shipping container for use in shipping the TRACER back for repair or for verification of damage during shipment.

Before beginning installation, verify that all of the following components are present.

Rackmounted RFC configuration:

- | | |
|----------------------|---|
| Provided by ADTRAN | <ul style="list-style-type: none"> • Baseband processor • Rackmounted RFC • BBP to RFC IF interconnect cable • DS1/DSX-1 interface cables (RJ-48 to RJ-48) |
| Provided by customer | <ul style="list-style-type: none"> • Antenna feedline cable • Antenna and mounting hardware • VT-100 terminal and RS-232 interface cable (optional) • 21 to 60 volt DC power source (available from ADTRAN), either polarity referenced to ground |

Mastmounted RFC configuration:

- | | |
|----------------------|---|
| Provided by ADTRAN | <ul style="list-style-type: none"> • Baseband processor • Mastmounted RFC • DS1/DSX-1 interface cables (RJ-48 to RJ-48) |
| Provided by customer | <ul style="list-style-type: none"> • Antenna feedline cable • Antenna and mounting hardware • BBP to mastmounted RFC IF interconnect cable • VT-100 terminal and RS-232 interface cable (optional) • 21 to 60 volt DC power source (available from ADTRAN), either polarity referenced to ground |

INSTALLATION

Location and Mounting

Install the TRACER in a location that requires minimal antenna feedline length (the loss in this cable directly affects overall system performance). The BBP is designed to be mounted in a rack, above the RFC. Although no space is needed between the units, certain regulations may require at least .75" of space above and below the BBP.

Power Requirements

The TRACER can operate from a supply between 21 and 60 volts DC, with either polarity referenced to ground, and consumes 30 watts. Amperage is determined by dividing the wattage (30) by the input voltage (i.e., $30 \text{ watts} / 48 \text{ volts} = .625 \text{ amps}$),

Grounding

The following grounding instructions are derived from the Underwriters' Laboratory *UL 1459 Standard for Safety: Telephone Equipment* dated September 20, 1993.

An equipment grounding conductor that is no smaller in size than the ungrounded branch-circuit supply conductors is to be installed as part of the circuit that supplies the product or system. Bare, covered, or insulated grounding conductors are acceptable. Individually covered or insulated equipment grounding conductors shall have a continuous outer finish that is either green, or green with one or more yellow stripes. The equipment grounding conductor is to be connected to ground at the service equipment.

The attachment-plug receptacles in the vicinity of the product or system are all to be of a grounding type, and the equipment grounding conductors serving these receptacles are to be connected to earth ground at the service equipment.

A supplementary equipment grounding conductor shall be installed between the product or system and ground that is in addition to the equipment grounding conductor in the power supply cord.

The supplementary equipment grounding conductor shall not be smaller in size than the undergrounded branch-circuit supply conductors. The supplementary equipment grounding conductor shall be connected to the product at the terminal provided, and shall be connected to ground in a manner that will retain the ground connection when the product is unplugged from the receptacle. The connection to ground of the supplementary equipment grounding conductor shall be in compliance with the rules for terminating bonding jumpers at Part K or Article 250 of the National Electrical Code, ANSI/NFPA 70. Termination of the supplementary equipment grounding conductor is permitted to be made to building steel, to a metal electrical raceway system, or to any grounded item that is permanently and reliably connected to the electrical service equipment ground.

Bare, covered, or insulated grounding conductors are acceptable. A covered or insulated grounding conductor shall have a continuous outer finish that is either green, or green with one or more yellow stripes.

The supplemental equipment grounding terminals are located on the rear of the BBP adjacent to the power connectors and on the rear of the rackmounted RFC.

Section 2 Installation

DS1/DSX-1 Interface

The rear panel of the TRACER has two sets of jacks labeled T1A and T1B which provide the same functionality. The pin assignments for the eight-position modular jack are listed below.

<u>Pin</u>	<u>Name</u>	<u>Function</u>
1	R	Send data (ring)
2	T	Send data (tip)
3		Not used
4	R1	Receive data (ring)
5	T1	Receive data (tip)
6		Not used
7		Not used
8		Not used

Bantam jack connections are provided for test equipment access. Data is received on the jack labelled “IN” and is transmitted on the jack labelled “OUT.” Bantam jacks are provided for both inserting and monitoring the interfaces. When a plug is placed in the insert jack, the connection between the modular jack and the interface circuitry is broken. The monitor jacks provide access to monitor the transmitted and received signals without interference.

When connecting either T1 interface to the public switched network, an ADTRAN-provided crossover cable (part number 3125M011@A) is required to meet FCC part 68 and IC CS03 requirements. This cable is required to cross-over the Tx and Rx pairs to meet the connecting arrangement of a network interface device. This cable, labelled “T1 Crossover,” is included with the BBP.

For connections to other CPE-type equipment, such as an ADTRAN TSU, a straight-through T1 cable (ADTRAN part number 3127004) is included with the BBP.

Each DS1/DSX-1 interface must be configured for line code and framing, either from the front-panel rocker switches or via the VT-100 terminal. The choices for line code are AMI and B8ZS. The options for framing are SF and ESF. Each channel can be configured independently of the other and should be configured to match the attached T1 equipment.

The line build-out (LBO) must be set for each DS1/DSX-1 interface. The LBO setting allows each DS1/DSX-1 interface transmitter to drive the interface with the correct signal strength based on the line attenuation between TRACER and the attached equipment. The LBO is independently set for each interface via rotary switches on the front panel. Two sets of configurations are provided -- DSX-1 for short-haul interface (less than 655 feet) and DS1 for long-haul interfaces (greater than 655 feet). The settings are detailed below.

<u>Interface Type</u>	<u>LBO</u>	<u>Switch Setting</u>
DSX-1	0-133 feet	2, 3
DSX-1	133-266 feet	4
DSX-1	266-399	5
DSX-1	399-533	6
DSX-1	533-655 feet	7
DS1	0 dB	8
DS1	-7.5 dB	9
DS1	-15 dB	10
DS1	-22.5 dB	11

LINK PLANNING**I M P O R T A N T**

The appropriate transmitter power must be calculated as part of the link planning.

The factors that must be taken into account when planning a link are optimal received signal level, transmitter power, antenna feedline loss (each end), antenna gain (each end), free space path loss, and required fade margin.

I M P O R T A N T

The optimal signal level for the receiver is -60 dBm.

Antenna Feedline Loss

Feedline loss is a function of feedline type and length. Feedline loss per 100 feet for several types of coax at IF and RF frequencies is detailed in the table below. The IF loss applies to BBP/RFC interconnection, and the RF loss applies to RFC/antenna interconnection. Antenna manufacturers' specifications may vary.

Cable	IF Loss/100 feet (in dB)	2.4 GHz RF Loss/100 feet (in dB)	5.7 GHz RF Loss/100 feet (in dB)
RG58	5.7	80	N/A
RG8 (air)	2.7	20	N/A
RG8 (foam)	2	9	N/A
1/4" Coax	1.42	5.91	11.36
3/8" Coax	1.25	5.76	9.65
1/2" Coax	0.81	3.83	6.49
7/8" Coax	0.44	2.2	N/A
1 1/4" Coax	0.33	1.62	N/A
1 5/8" Coax	0.27	1.41	N/A
5.8 GHz Elliptical Waveguide	N/A	N/A	1.23

Antenna Gain

Best performance will result from the use of a parabolic dish antenna. Antenna gain is determined by the size of the dish, with typical figures detailed below. Dish manufacturers will be able to supply gains for other types of antenna.

Dish Diameter (in feet)	2.4 GHz Gain (in dBi)	5.8 GHz Gain (in dBi)
2	21	28.5
4	27	34.2
6	31	37.5
8	33	40.7
10	35	42.5
12	37	44.2

Section 2 Installation

Path Loss

The free space path loss is given by

$$Loss(dB) = 96.6 + 20 \log_{10} f + 20 \log_{10} D$$

where D is distance in miles

f is operating frequency in GHz

A tabulation of various path loss is given below.

2.4 GHz		2.4 GHz		5.8 GHz		5.8 GHz	
Link Distance (in miles)	Path Loss (in dB)	Link Distance (in miles)	Path Loss (in dB)	Link Distance (in miles)	Path Loss (in dB)	Link Distance (in miles)	Path Loss (in dB)
1	104	13	126	1	112	13	134
2	110	14	127	2	118	14	135
3	114	15	128	3	121	15	135
4	116	16	128	4	124	16	136
5	118	17	129	5	126	17	136
6	120	18	129	6	127	18	137
7	121	19	129	7	129	19	137
8	122	20	130	8	130	20	138
9	123	21	130	9	131	21	138
10	124	22	131	10	132	22	139
11	125	23	131	11	133	23	139
12	126	24	132	12	133	24	139

Path Availability

The availability of a path can be expressed by:

$$availability = (1 - C \times T \times 2.5 \times 10^{-6} \times f \times D^3 \times 10^{-F/10}) \times 100\%$$

where C is the climate factor

T is the terrain factor

f is the frequency in GHz

D is the path length in miles

F is the fade margin in dB

Climate factors are given below.

<u>Climate</u>	<u>Climate Factor</u>
Very Dry	$1/8$
Temperate	$1/4$
Humid	$1/2$

Terrain factors are listed below.

<u>Terrain</u>	<u>Terrain Factor</u>
Smooth	4
Average	1
Mountainous	$1/4$

The nominal received signal level is -60 dBm. For help in link planning, use the path loss calculation worksheet below.

$$\begin{array}{rcl}
 - & 91 \text{ dBm } (-90 \text{ dBm for } 5.8 \text{ GHz}) & \text{..... Minimum Signal Power} \\
 + & \underline{\hspace{2cm}} & \text{..... Transmitter Feedline Loss} \\
 - & \underline{\hspace{2cm}} & \text{..... Transmitter Antenna Gain} \\
 + & \underline{\hspace{2cm}} & \text{..... Path Loss} \\
 - & \underline{\hspace{2cm}} & \text{..... Receiver Antenna Gain} \\
 + & \underline{\hspace{2cm}} & \text{..... Receiver Feedline Loss} \\
 + & \underline{\hspace{2cm}} & \text{..... Required Fade Margin} \\
 = & \underline{\hspace{2cm}} & \text{..... (dBm) Transmitter Power Setting}
 \end{array}$$

SETTING THE TRANSMITTER POWER

The FCC specifies the maximum transmitter power that may be used for antennae of a given gain. FCC rules Part 15, Subpart 247 allow for a maximum power of 1 watt into antennae of a gain less than or equal to 6 dBi. For every 3 dB of gain over 6 dBi, the transmitter must be reduced by 1 dB. The following table lists the maximum transmitter power for given antennae gains. For the 5.8 GHz band, there is no reduction in transmitter output power required for antennae gains greater than 6 dBi.

<u>Antenna Gain</u>	<u>Power</u>
6 dBi	30 dBm (TRACER & 2.4 GHz 1 watt output option)
12 dBi	28 dBm (TRACER & 2.4 GHz 1 watt output option)
18 dBi	26 dBm (TRACER & 2.4 GHz 1 watt output option)
24 dBi	24 dBm (TRACER & 2.4 GHz 1 watt output option)
30 dBi	22 dBm (TRACER & 2.4 GHz 1 watt output option)
36 dBi	20 dBm (TRACER standard output option)

The transmitter power is set by way of a potentiometer on the front panel of the BBP or via the configuration page of the interface VT-100. The RFC must be attached by way of the IF cable during this operation. Attach an RF power meter to the N-type antenna connector on the RFC, and adjust the power by way of the potentiometer or VT-100 until the desired transmitter power is obtained. For convenience, the transmitter power adjustment should be made before the RFC is installed on the mast.

2.4 GHZ, 1 WATT TRANSMITTER OPTION

The 2.4 GHz Tracer model is offered with a standard +20 dBm power output or optional 1 watt power output option. The 1 watt option provides an add-on amplifier that is installed in the rackmount RFC chassis. This amplifier is connected to the transmit cable of the RFC module and amplifies the +20 dBm output power to a maximum level of +30 dBm (1 watt), factory set to +27 dBm. The output power is proportional to the output level from the RFC module. The level is adjusted via the Baseband Processor front panel or VT-100 terminal.

Because the 1 watt amplifier is frequency specific, the frequency plans can not be manually changed by swapping the TX and RX cables in the RFC chassis. If a frequency reversal is required, the rackmount RFCs will have to be relocated to the opposite ends of the microwave path. The 1 watt option is only available for the 2.4 GHz, rackmount Tracer systems.

Section 2 Installation

SETTING THE RFC FREQUENCY PLAN ON NON 1 WATT 2.4 GHz MODELS

The frequency plan designates on which frequencies the TRACER transmits and receives. Plan A corresponds to a transmitting (Tx) frequency of 2422 MHz and a receive (Rx) frequency of 2462 MHz. Plan B corresponds to a Tx frequency of 2462 MHz and a Rx frequency of 2422 MHz. Shipment of a link consists of one RFC set to Plan A and the other set to Plan B unless specified otherwise. The RFC plan can, however, be changed in the field if required if the 1 watt amplifier is not present. This procedure involves configuring the RFC interconnect cables.

For rackmounted systems, do the following to reconfigure the RFC interconnect:

1. Remove the SIX screws which retain the RFC cover and remove the cover.
2. The RF unit may be identified by following the connection from the port labelled “IF” on the rear of the RFC. This connection terminates at the RF unit. The diplexer may be identified by following the connection from the “Antenna” port on the rear of the RFC. This connection terminates at the diplexer, illustrated in **Figure 2-1**.

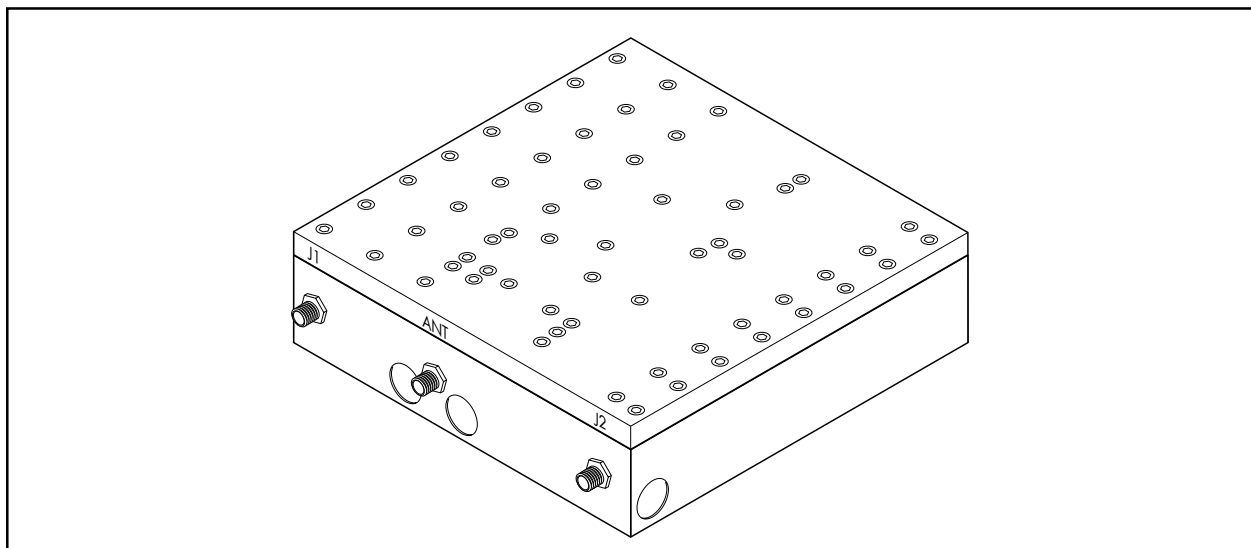

Figure 2-1. 2.4 GHz Diplexer

3. Unscrew the cable assemblies from the ports labelled “Tx” and “Rx” on the RFC, and the ports labelled “J1” and “J2” on the diplexer, depending on the frequency Plan (Plan A or Plan B).
4. Unscrew the cable assembly from the port labelled “Antenna” on the diplexer.
5. Remove the four screws from the bottom of the RFC that hold the diplexer in place.
6. Turn the diplexer over revealing the opposite frequency plan (from Plan A to Plan B, or vice versa).
7. Realign the diplexer with the screw holes and replace the four screws that attach it to the bottom of the RFC.
8. Reattach the loose cable assembly (from step 4) to the port labelled “Antenna” on the diplexer.

Section 2 Installation

- Reattach the cable assemblies from the ports labelled “Tx” and “Rx” on the RFC, and the ports labelled “J1” and “J2” on the diplexer. Cable connections should be aligned to each other as follows:

Plan A

Tx = 2422

Rx = 2462

Plan B

Tx = 2462

Rx = 2422

- Replace and secure the RFC cover.

For mastmounted systems, do the following to reconfigure the RFC interconnect:

- Remove the lid of the mast RFC.
- Disconnect the three cables attached to the diplexer. The diplexer may be identified by following the antenna connector to the middle connector of the diplexer. Leave the cables in the same positions.
- Remove the two screws securing the diplexer and rotate the diplexer to reveal the opposite frequency plan label.
- Reinstall the two screws and reattach the cables in the same positions.
- Reinstall the lid of the mast RFC.

SETTING THE RFC FREQUENCY PLAN ON 5.8 GHz MODELS

The 5.8 GHz RFC operates on Plan A, Tx = 5747 MHz, Rx = 5827 MHz or Plan B, Tx = 5827 MHz, Rx = 5747 MHz. See **Figure 2-2** for an illustration of the 5.8 GHz diplexer.

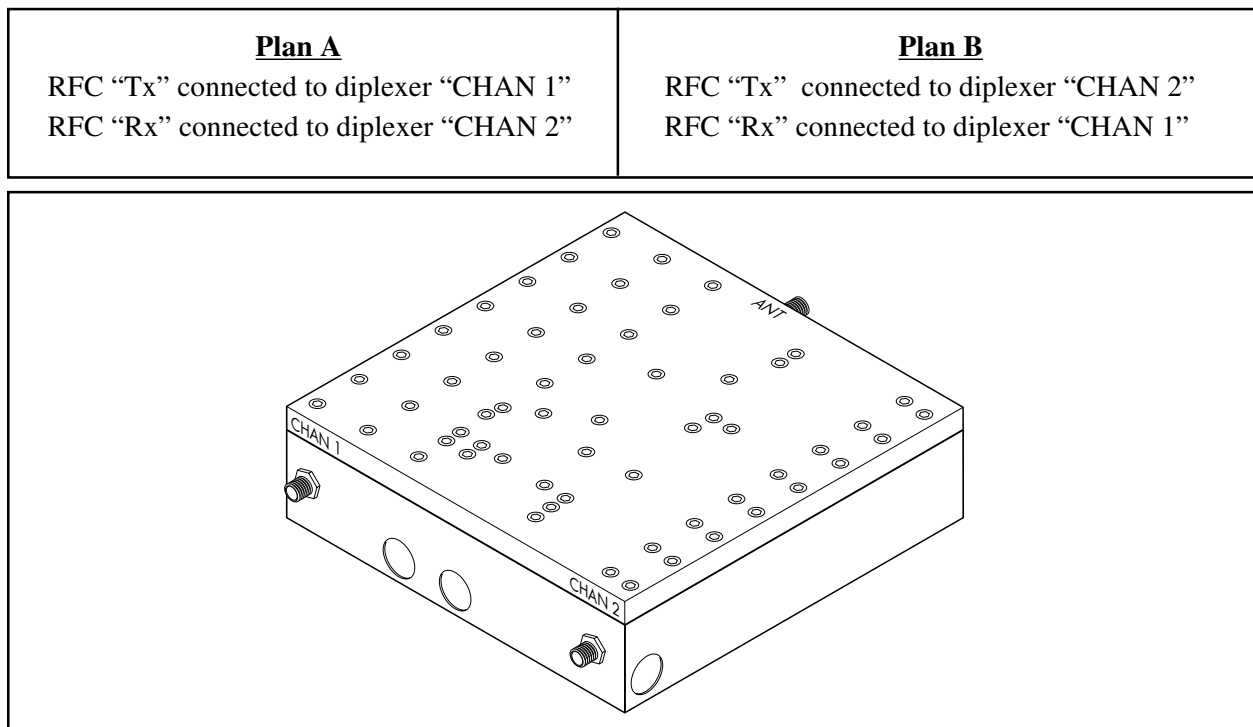

Figure 2-2. 5.8 GHz Diplexer

Section 2 Installation

Directions for Changing the Frequency Plan on the Rack Mount RFC

1. Remove RFC top cover by removing six screws.
2. Disconnect the cables at the “Tx” and “Rx” RFC module ports. Swap and reconnect these two cables to the RFC module ports. Minimum bend radius on these cables is 3/4 inch. Use care in handling and forming bends in these cables.
3. Reinstall the RFC top cover with the six screws previously removed.

Directions for Changing the Frequency Plan on the Mast Mount RFC

1. Remove the lid of the Mast RFC.
2. Disconnect the two cables at both ends; at the diplexer and RFC module.
3. Swap and reconnect these cables. Minimum bend radius on these cables is 3/4 inch. Use care in handling and forming bends in these cables.
4. Reinstall the lid of the Mast RFC.

CONNECTING THE BBP AND THE RFC

The BBP and the RFC are connected by an IF cable, either supplied by ADTRAN (for rackmount assembly) or by the customer (for mastmount assembly). This single connection provides everything the RFC requires. The cable assembly attaches to the ports labeled “IF” on the BBP and the RFC.

APPLYING POWER

If the ADTRAN supplied tabletop power source is used, simply plug it into the circular receptacle located in the “DC Power” area on the rear of the BBP. If a source of 21 to 60 volts DC (30 watts), either polarity referenced to ground, is available, it may be attached to the terminal block located on the rear of the BBP. The positive lead should be attached to the “+” side of the block and the negative lead should be attached to the “-” side of the block.

CAUTION

Power sources must not be attached to both the circular connector and the terminal blocks at the same time or damage will occur.

AUTOMATIC BBP FREQUENCY PLAN

Upon the initial application of power, the BBP will default to the factory-preset Frequency Plan, or to the Frequency Plan determined by the cable configuration of the RFC. The LED will indicate which frequency plan is active. On subsequent reboots, such as after a loss of power, the BBP will default to the most recently used Plan setting.

SPREADING CODE

The spreading code for each end must be the same. The choice of operating code is selectable by the operator or the installer. TRACER is shipped in a matched (default) configuration.

WARNING

It is possible for the spreading code to be changed remotely through the VT-100 interface from the other end of the link. When this is performed, communications will be lost to the far end. The spreading code will change to code “0” and communications will be lost as soon as this change is made. If this happens, set the Spreading Code on the local unit to code “0”. The units should regain communications as soon as the correct code is selected.

CO-LOCATING MULTIPLE SYSTEMS

When multiple transmitters are to be co-located (installed in the same equipment room or on the same tower), it is advised to set all systems as follows:

1. If more than one system is transmitting from the same location, set the antenna polarity of one system *horizontal* and the other system(s) *vertical* if the systems are operating in the same frequency bands. (The antennas should be marked as to which mounting position is vertical or horizontal.) This will provide approximately 30 dB of isolation between the different antennas.
2. If more than one TRACER system is installed, set the co-located transmitters to the same frequency plan (example: Plan A, Tx=2422; or Plan B, Tx=2462) and set each to a different spreading code. This keeps the transmitters on the additional system(s) from interfering with the co-located receiver(s).
3. If the systems are from different manufacturers, set the transmit frequencies as close as possible with different spreading codes. Other manufacturers may not use the exact frequency plans as the TRACER system, but keeping the frequencies close will reduce the probability of the transmitter(s) interfering with the co-located receiver(s).

This equipment is authorized under CFR 47 Part 15.247. With this authorization by the FCC, this equipment shall not be co-located with a similar transmitter that transmits identical information.

ANTENNA ALIGNMENT

After the transmitter power for each end has been adjusted and the BBP and RFC have been installed and connected, the antenna should be connected to the RFC via the feedline. Verify that both antennas are arranged on the same polarity: vertical or horizontal. The antennas should be aimed toward one another as precisely as possible and the received signal strength indicator (RSSI) voltage measured. The RSSI voltage is a function of the signal strength at the receiver and is used to measure the received signal strength. RSSI varies approximately from 0 to 4 volts, with 0 volts corresponding to a weaker received signal and 4 volts corresponding to a stronger received signal.

Section 2 Installation

RF LOW

The “RF Low” LED indicates that the received signal is within 10dB of the minimum received signal strength (~-80 dBm). If this indicator is on, the link performance may be marginal. The antennas should be peaked in azimuth and elevation until the desired signal level is achieved. RSSI may be monitored on either the RF unit or the front of the BBP. If the received signal is too strong and RSSI reaches a maximum such that the peak cannot be discerned, then the transmitter on the far end should be turned down.

At this point the radio link should be operational. Proper operation can be determined by the status of the “LINK DOWN” LED. If this LED is *on*, the link *is not* operational. If this LED is not on, the link is operating. Certain types of interference can cause one end of a path to operate and the other end to fail. In some instances, this may be corrected by swapping the frequency plan at each end, thus avoiding the interference if it is stronger at one end than the other. Changing the spreading code at each end may also allow interference to be mitigated.

REMOTE BERT

The TRACER includes a Bit Error Rate Tester (BERT) to verify that the installed system is operating correctly. When the “Remote Test” button is pushed on the local BBP, the remote end will send a BERT pattern for approximately 10 seconds. The “Remote TST” indicator will turn yellow and remain on for the duration of the test. If no bit errors are detected, the “Remote TST” indicator will turn off. If any bit errors are detected, the “Remote Fail” indicator will turn red. This test should be run after the radio link has been aligned. If the test fails, refer to Section 4, “Troubleshooting,” for guidance.

ALARM CONTACTS

Two sets of alarm contacts are provided on the rear of the BBP: major alarm and minor alarm. A major alarm indicates the radio link is not operational. A minor alarm indicates that system performance is degraded or that the T1 interfaces are experiencing errors. Normally-open and Normally-closed contacts are provided for both alarm types. Under normal operating conditions there is no continuity between the Normally-open and Common contacts and under an alarm condition continuity between those contacts exists. The Normally-closed and Common contacts normally have continuity, while under alarm conditions, these contacts are open.

VT-100 USER INTERFACE

The TRACER may be accessed with a VT-100 compatible terminal set to 9600 bits per second, 8 data bits, and no parity, connected to the RS-232 port on the back of the unit. Once a terminal is connected, pressing the ESC key will present the System Status screen. If password access has been enabled, then press “Enter” or “Return” in order to see the “Enter Password:” message. TRACER is shipped with password protection disabled.

RS-232 INTERFACE

The TRACER has an RS-232 interface for system management via an attached VT-100 terminal, personal computer, or modem. The RS-232 port is configured as a DCE with the following pin assignments:

<u>Signal Name</u>	<u>Pin Number</u>	<u>Direction</u>
TXD	2	To TRACER
RXD	3	From TRACER
RTS	4	To TRACER
CTS	5	From TRACER
DSR	6	From TRACER
Ground	7	
DCD	8	To TRACER
DTR	20	To TRACER

MODEM CONNECTION

Option 16, discussed in the Configuration Menu page of this section, will enable or disable modem control. When this option is enabled from a standard terminal connection, all RS-232 communications will cease until a modem is attached with a Null-Modem adapter between the TRACER and data modem. The data modem will need to be configured for AUTO ANSWER and 9600 BPS. When the user connects via modem to the TRACER unit, communications via the RS-232 port will resume. If a user accidentally enables modem control from a terminal and disrupts the RS-232 communication, pressing [CTRL Z] three times, will temporarily disable the modem control option. This will allow the user to access the configuration menu to disable modem control.

When modem control is enabled, the RS-232 port is inactive until DTR and DCD are active. This prohibits data being sent to the modem or received from the modem while idle. The required Null-Modem adapter may be obtained at any computer hardware supplier. A straight-through serial cable should be used between the adapter and the modem or TRACER unit. To ensure that the far-end modem disconnects when desired, option 17 of the CONFIGURATION MENU will disconnect the modem. The modem must be configured to drop the connection on loss of DTR in order to disconnect.

TELEMETRY BYTE ORIENTED SERIAL (TBOS) INTERFACE

E-telemetry systems were developed by the pre-divestiture AT&T organization as a method to monitor and control diverse network elements from a remote, centralized location. Status and command remote (SAC) units were employed in the central office to convert discrete (contact closure) alarms from monitored equipment into E-telemetry for efficient transfer of data to and from the operations center.

Section 3 Operation

With the advent of microprocessor technology, the alarm processing remote (APR, alarm remote or simply Remote) was developed, allowing discrete alarm links with network elements to be supplanted by a more efficient serial link. TBOS is the communications protocol defined for this link.

The TRACER rear panel designates the TBOS ports as “MANAGEMENT IN” (on the bottom) and “MANAGEMENT OUT” (on the top). The TBOS polling station is connected to the MANAGEMENT IN port. If several devices or TRACER systems are daisy-chained together, plug the TBOS manager into the first units MANAGEMENT IN port (that physical unit does not have to be assigned TBOS address #1), and then connect that units MANAGEMENT OUT to the next units MANAGEMENT IN port. Follow that routine down the line, up to 8 units.

TBOS operates via RS422, therefore the inputs and outputs are differential pairs. The pinout for the MANAGEMENT IN port is:

- pin 1 - Transmit- (out of TRACER)
- pin 3 - Transmit+ (out of TRACER)
- pin 5 - Receive- (in to TRACER)
- pin 7 - Receive+ (in to TRACER)

The pinout for the MANAGEMENT OUT port is:

- pin 1 - Receive- (in to TRACER)
- pin 3 - Receive+ (in to TRACER)
- pin 5 - Transmit- (out of TRACER)
- pin 7 - Transmit+ (out of TRACER)

The rear panel connectors are on a double-stack RJ45, so the pin numbers are opposite of each other: A TBOS monitoring system will need to define the following bitmaps to indicate status and alarm conditions.

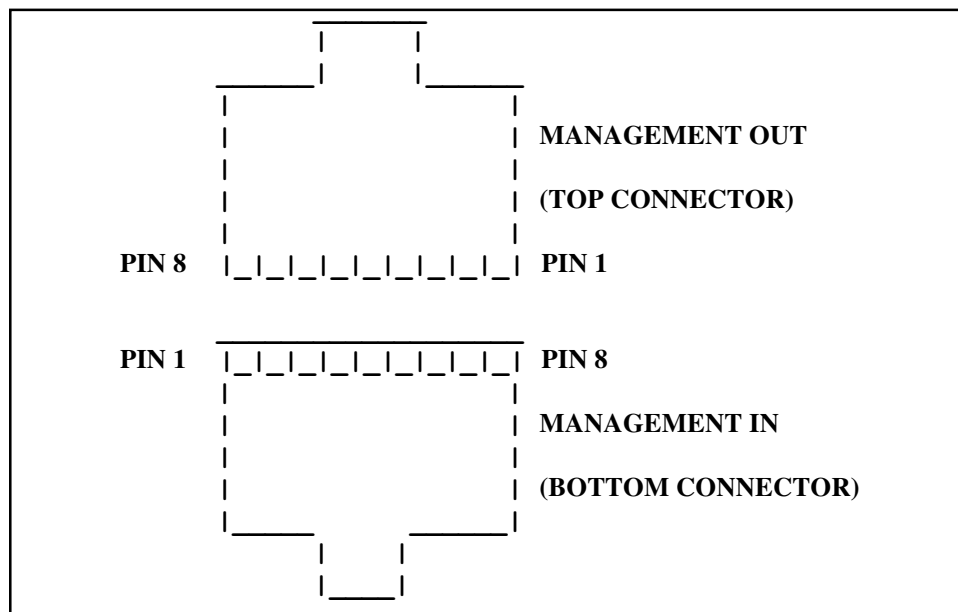

Figure 3-1. Rear Panel Connectors

Section 3 Operation

A TBOS monitoring system will need to define the following bitmaps to indicate status and alarm conditions.

Table 3-1. TRACER TBOS Alarm and Status Map

Char. / Point	Type	Scan Point Definition	Description
1 / 1	Status	Frequency Plan	0 = Plan A, 1 = Plan B
1 / 2	Status	10 Second BERT Test	0 = Normal, 1 = In Test
1 / 3	Status	Local T1A Line Loopback	0 = Normal, 1 = Loop
1 / 4	Status	Local T1B Line Loopback	0 = Normal, 1 = Loop
1 / 5	Status	Local T1A Link Loopback	0 = Normal, 1 = Loop
1 / 6	Status	Local T1B Link Loopback	0 = Normal, 1 = Loop
1 / 7	Status	Remote T1A Link Loopback	0 = Normal, 1 = Loop
1 / 8	Status	Remote T1B Link Loopback	0 = Normal, 1 = Loop
2 / 1	Alarm	RFC Link Fail	0 = Normal, 1 = Alarm
2 / 2	Alarm	Code Sync Fail	0 = Normal, 1 = Alarm
2 / 3	Alarm	Carrier Sync Fail	0 = Normal, 1 = Alarm
2 / 4	Alarm	T1 Mux Sync Fail (Link Err)	0 = Normal, 1 = Alarm
2 / 5	Alarm	Remote RF Link Down	0 = Normal, 1 = Alarm
2 / 6	Alarm	RF Low	0 = Normal, 1 = Alarm
2 / 7	Alarm	Remote Test Fail	0 = Normal, 1 = Alarm
2 / 8		Unused	
3 / 1	Alarm	T1A BPV	0 = Normal, 1 = Alarm
3 / 2	Alarm	T1A Red Alarm	0 = Normal, 1 = Alarm
3 / 3	Alarm	T1A Yellow Alarm	0 = Normal, 1 = Alarm
3 / 4	Alarm	T1A AIS (Blue Alarm)	0 = Normal, 1 = Alarm
3 / 5	Alarm	T1A Transmit AIS	0 = Normal, 1 = Alarm
3 / 6		Unused	
3 / 7		Unused	
3 / 8		Unused	
4 / 1	Alarm	T1B BPV	0 = Normal, 1 = Alarm
4 / 2	Alarm	T1B Red Alarm	0 = Normal, 1 = Alarm
4 / 3	Alarm	T1B Yellow Alarm	0 = Normal, 1 = Alarm
4 / 4	Alarm	T1B AIS (Blue Alarm)	0 = Normal, 1 = Alarm
4 / 5	Alarm	T1B Transmit AIS	0 = Normal, 1 = Alarm
4 / 6		Unused	
4 / 7		Unused	
4 / 8		Unused	

Section 3 Operation

Table 3-2. TRACER TBOS Command Map

Command #	Command Type	Command Definition
1	Latch	10 Second Remote Test
2	Latch or Unlatch	Local T1A Line Loopback
3	Latch or Unlatch	Local T1B Line Loopback
4	Latch or Unlatch	Local T1A Link Loopback
5	Latch or Unlatch	Local T1B Link Loopback
6	Latch or Unlatch	Remote T1A Link Loopback
7	Latch or Unlatch	Remote T1B Link Loopback

Table 3-3. Alarm, Status and Command Overview

Item	Description
Frequency Plan	A = 2422 MHz TX, 2462 MHz RX or 5747 MHz Tx, 5827 MHz Rx B = 2462 MHz TX, 2422 MHz Rx or 5827 MHz Tx, 5747 MHz Rx
10 Second BERT Test	Remote end sends BERT pattern for 10 seconds
Local T1A Line Loopback	Loops local T1A interface towards local CPE
Local T1B Line Loopback	Loops local T1B interface towards local CPE
Local T1A Link Loopback	Loops local T1A interface towards remote CPE over the RF link
Local T1B Link Loopback	Loops local T1B interface towards remote CPE over the RF link
Remote T1A Link Loopback	Loops remote T1A interface towards local CPE over the RF link
Remote T1B Link Loopback	Loops remote T1B interface towards local CPE over the RF link
RFC Link Fail	Active if the command link between the baseband processor and the RF
converter is down	
Code Sync Fail	Active if the link fails to achieve code sync
Carrier Sync Fail	Active if the link fails to achieve carrier sync
T1 Mux Sync Fail (Link Error)	Active if the T1C Mux fails to achieve sync
Remote RF Link Down	Active if the remote Tracer unit is not receiving data
RF Low	Active if receive power is below -80 dBm
Remote Test Fail	Active if the 10 second BERT has failed over the RF link to the far end
T1A BPV	Active when the T1A incoming data stream presents bipolar violations
T1A Red Alarm	Active when there is no signal present at the T1A interface
T1A Yellow Alarm	Active when the far end T1A equipment is in red alarm
T1A AIS (Blue Alarm)	Active when the T1A DS1/DSX-1 is receiving a blue alarm code (all ones)
T1A Transmit AIS	Active when T1A is transmitting a blue alarm code (all ones)
T1B BPV	Active when the T1B incoming data stream presents bipolar violations
T1B Red Alarm	Active when there is no signal present at the T1B interface
T1B Yellow Alarm	Active when the far end T1B equipment is in red alarm
T1B AIS (Blue Alarm)	Active when the T1B DS1/DSX-1 is receiving a blue code (all ones)
T1B Transmit AIS	Active when the T1B DS1/DSX-1 is transmitting a blue code (all ones)

Table 3-4. Discreet Alarm Summary

Alarm Type	Interface	Description
Major	RF	T1 Mux Sync Fail (Link Error)
Minor	RF	RF Low
Minor	T1A	Yellow Alarm
Minor	T1A	Bipolar Violations
Minor	T1A	Received AIS (Blue Alarm)
Minor	T1A	Carrier Loss
Minor	T1A	Sync Loss
Minor	T1A	Data Loss
Minor	T1B	Yellow Alarm
Minor	T1B	Bipolar Violations
Minor	T1B	Received AIS (Blue Alarm)
Minor	T1B	Carrier Loss
Minor	T1B	Sync Loss
Minor	T1B	Data Loss
<p>Major and minor alarm contacts are provided on the rear of the baseband processor. A major alarm indicates the radio link is not operational. A minor alarm indicates that system performance is degraded or that the T1 interfaces are experiencing errors.</p>		

MAIN MENU SELECTIONS

System Status Page

This page displays the status of major system components. This is a status screen only; no configurations can be performed. More detailed information can be obtained by way of the Main Menu.

```

Current System Status
Elapsed Time 00:03:22
Adtran Technical Support- 800/726-8663

-----
T1A ==| C | / ---->>>>-->>>-->>-->--[RF UP]-->>>>-->>>-->>--> \ | C | == T1A
      | S |#(- ---->>>>-->>>-->>-->-->>>-->>>-->>--> -) #| S |
T1B ==| U | \ <---<---<---<---<---<---<---<---<---<---<---<---<---<---<--- / | U | == T1B
-----

Local Tracer                               Remote Tracer
Freq Plan A                               Freq Plan B

Tx Pwr  Rx Pwr                               Tx Pwr  Rx Pwr
Max [X]  [X] Nominal                         Max [X]  [X] Nominal
[X]      [X]
[X]      [X]
[X]      [X]
[X]      [X]
[X]      [X]
[X]      [X]
[X]      [X]
[X]      [X]
[X]      [X]
[X]      [X]
[X]      [X]
[X]      [X]
[X]      [X]
[X]      [X]
[X]      [X]
[X]      [X]
Min [X]  [X] Min                             Min [X]  [X] Min

-----
Site: ADTRAN
RFC Link Up: Yes
Code Sync: Yes
Carrier Sync: Yes
T1 Mux Sync: Yes
Chipping Code: 0
-----
Press 'm' - Main menu:

```

Figure 3-3. System Status Page

The upper portion of the screen indicates how long the system has been running since the last reset operation. The “T1A” and “T1B” labels will be highlighted if any error conditions exist on that T1 interface.

The status of the radio link is indicated as Up or Down. The left portion of the screen reports the status of the local system (the system to which the terminal is attached); the right portion reports the status of the remote system. The approximate transmitter and receiver signal levels are shown via the “fuel gauges.” If the link is down and remote end data is unavailable, the fuel gauges will show “-” instead of “x.” The Code Sync, Carrier Sync, and T1 Mux Sync will all be “yes” for an operational link. Chipping code indicates the code to which the system is set. At any point in the VT-100 menu structure, pressing the Escape key will bring the operator back to this screen.

Section 3 Operation

Main Menu Page

Pressing “M” on any screen will take the user to the Main Menu, from which the subsequent screens can be accessed.

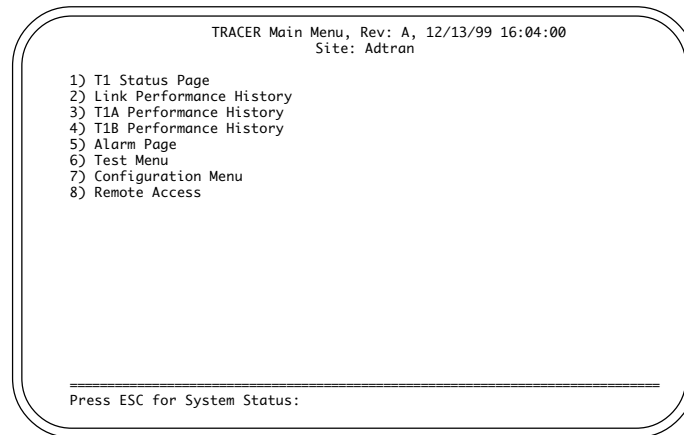

Figure 3-4. Main Menu Page

T1 Status Page

The status of the two T1 interfaces is displayed on this screen. Information such as alarm status, T1 receive levels, line coding, and framing type are shown. This is a status screen only.

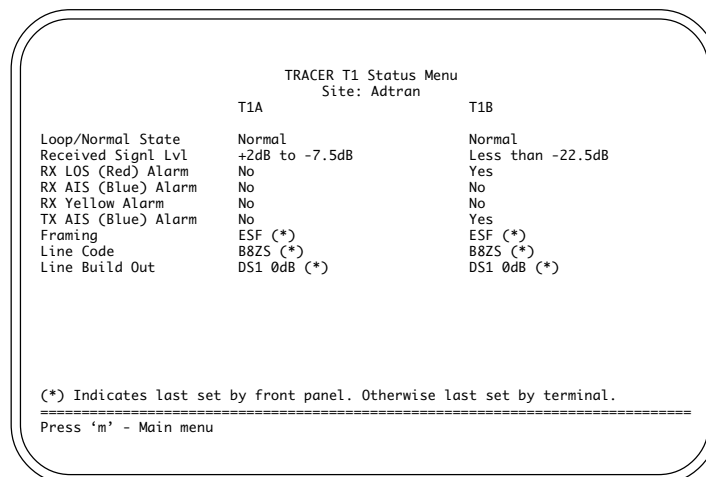

Figure 3-5. T1 Status Page

Link Performance History

This screen presents detailed error statistics for the RF link. The data is presented as RFCL (Radio Frequency Converter Link) and LINK (RF Link) representing seconds out of service for each. The RFCL represents the communications channel between the BBP and RFC via the IF interconnect cable. The counts for the most recent 24 hours are recorded in 15-minute increments. Twenty-four-hour totals are recorded for the most recent days.

TRACER Link Performance History		
Site: Adtran		
24 Hour Registers		15 Minute Registers
-RFCL-LINK--		-RFCL-LINK-----RFCL-LINK-
00000 00000	<-- Current -->	000 000
-1: -----		- 1: --- --- -17: --- ---
-2: -----		- 2: --- --- -18: --- ---
-3: -----		- 3: --- --- -19: --- ---
-4: -----		- 4: --- --- -20: --- ---
-5: -----		- 5: --- --- -21: --- ---
-6: -----		- 6: --- --- -22: --- ---
-7: -----		- 7: --- --- -23: --- ---
		- 8: --- --- -24: --- ---
		- 9: --- --- -25: --- ---
		-10: --- --- -26: --- ---
		-11: --- --- -27: --- ---
		-12: --- --- -28: --- ---
		-13: --- --- -29: --- ---
		-14: --- --- -30: --- ---
		-15: --- --- -31: --- ---
		-16: --- --- -32: --- ---

Press 'm' - Main menu, 'p' - Prev pg, 'n' - Next pg:

Figure 3-6. Link Performance History Page

Channel A Statistics Page

This screen presents detailed error statistics for T1A. The data is presented as Errored Seconds and Severely Errored Seconds. The counts for the most recent 24 hours are recorded in 15-minute increments. Twenty-four-hour totals are recorded for the most recent days.

TRACER T1A Performance History		
Site: Adtran		
24 Hour Registers		15 Minute Registers
--ES---SES--		--ES-SSES-----ES-SSES-
00000 00000	<-- Current -->	000 000
-1: -----		- 1: --- --- -17: --- ---
-2: -----		- 2: --- --- -18: --- ---
-3: -----		- 3: --- --- -19: --- ---
-4: -----		- 4: --- --- -20: --- ---
-5: -----		- 5: --- --- -21: --- ---
-6: -----		- 6: --- --- -22: --- ---
-7: -----		- 7: --- --- -23: --- ---
		- 8: --- --- -24: --- ---
		- 9: --- --- -25: --- ---
		-10: --- --- -26: --- ---
		-11: --- --- -27: --- ---
		-12: --- --- -28: --- ---
		-13: --- --- -29: --- ---
		-14: --- --- -30: --- ---
		-15: --- --- -31: --- ---
		-16: --- --- -32: --- ---

Press 'm' - Main menu, 'p' - Prev pg, 'n' - Next pg:

Figure 3-7. Channel A Statistics Page

Section 3 Operation

Channel B Statistics Page

This screen presents detailed error statistics for T1B. The data is presented as Errored Seconds and Severely Errored Seconds. The counts for the most recent 24 hours are recorded in 15-minute increments. Twenty-four-hour totals are recorded for the most recent days.

TRACER T1B Performance History			
Site: Adtran			
24 Hour Registers		15 Minute Registers	
--ES--SES--		--ES--SES-----ES--SES-	
00000 00000		<-- Current -->	
000 000			
-1: -----	- 1: --- ---	-17: --- ---	
-2: -----	- 2: --- ---	-18: --- ---	
-3: -----	- 3: --- ---	-19: --- ---	
-4: -----	- 4: --- ---	-20: --- ---	
-5: -----	- 5: --- ---	-21: --- ---	
-6: -----	- 6: --- ---	-22: --- ---	
-7: -----	- 7: --- ---	-23: --- ---	
	- 8: --- ---	-24: --- ---	
	- 9: --- ---	-25: --- ---	
	-10: --- ---	-26: --- ---	
	-11: --- ---	-27: --- ---	
	-12: --- ---	-28: --- ---	
	-13: --- ---	-29: --- ---	
	-14: --- ---	-30: --- ---	
	-15: --- ---	-31: --- ---	
	-16: --- ---	-32: --- ---	

Press 'm' - Main menu, 'p' - Prev pg, 'n' - Next pg:

Figure 3-8. Channel B Statistics Page

Alarm Page

This screen presents alarm information for the system. The T1A or T1B alarms are described in the chapter entitled “Troubleshooting.” If any of the T1A or T1B alarms are active, a minor alarm will be indicated at the alarm contacts. The RF link alarm will be activated when communication between the BBP and the RFC has failed. Code Sync, Carrier Sync, and T1 Mux Framer alarms indicate that various portions of the spread spectrum data pump are not operating. Any of these alarms will cause a major alarm to be activated at the alarm contacts.

TRACER Alarm Page		
Site: Adtran		
Code Sync Alarm	Off	
Carrier Sync Alarm	Off	
T1Mux Framer Alarm	Off	
	T1A	T1B
RX LOS (Red) Alarm	Off	Off
RX AIS (Blue) Alarm	Off	Off
RX Yellow Alarm	Off	Off
BPV Alarm	Off	Off
TX AIS (Blue) Alarm	Off	Off

Press 'm' for Main Menu:

Figure 3-9. Alarm Page

Test Menu

This screen allows each T1 to be put into loopback mode.

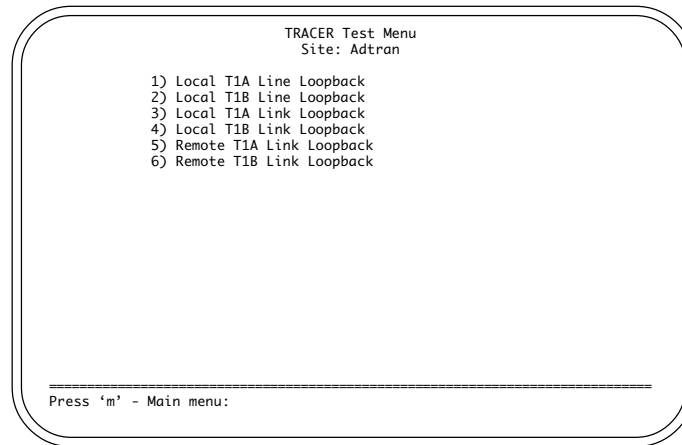

Figure 3-10. Test Menu

Each menu selection is described below:

1. Loops the local T1-A Interface towards the local customer equipment.
2. Loops the local T1-B Interface towards the local customer equipment.
3. Loops the local T1-A interface towards the remote customer equipment, over the RF Link.
4. Loops the local T1-B interface towards the remote customer equipment, over the RF Link.
5. Loops the remote T1-A Interface towards the local customer equipment, over the RF Link.
6. Loops the remote T1-B Interface towards the local customer equipment, over the RF Link.

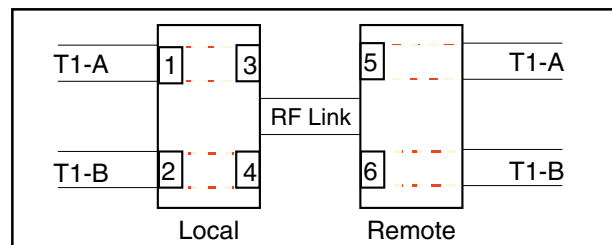

Figure 3-11. T1 Loopback Locations

Section 3 Operation

Configuration Menu

This screen allows all system configurations to be performed.

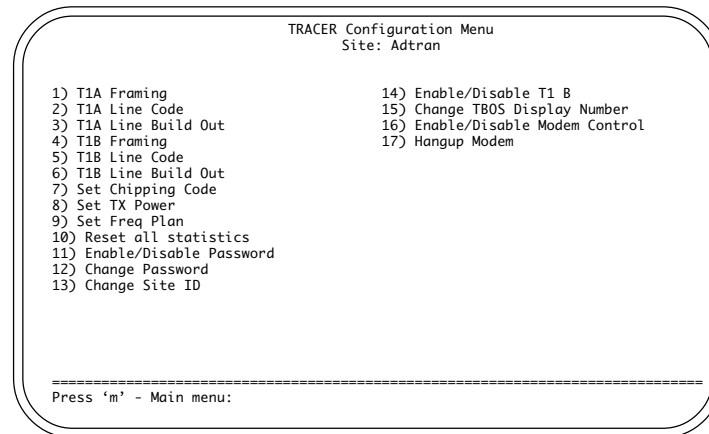

Figure 3-12. Configuration Menu

The menu selections are described below.

T1A and T1B Framing allow each T1 to be configured for SF or ESF framing.

T1A and T1B Line Code allow each T1 to be configured for AMI or B8ZS.

T1A and T1B Line Buildout allow each T1 to be configured for the appropriate line buildout, based on the distance to the T1 equipment.

WARNING

It is possible for the spreading code to be changed remotely through the VT-100 interface from the other end of the link. When this is performed, communications will be lost to the far end. The spreading code will change to code “0” and communications will be lost as soon as this change is made. If this happens, set the Spreading Code on the local unit to code “0.” The units should regain communications as soon as the correct code is selected.

Set Chipping Code allows the chipping code to be selected. Each end of the link must be configured for the same chipping code.

Set Tx Power allows the transmitter power to be adjusted.

Set Freq Plan manually allows the frequency plan to be set to A or B. One end of a link must be set to A and the other set to B. This function is automatically set when the BBP is attached to the corresponding RFC.

Reset All Statistics resets all the error counters.

Enable/Disable Password allows password protection to be enabled or disabled. The default setting is Disabled.

Change Password allows the password to be set.

Section 3 Operation

GENERAL

If you experience a problem with the TRACER system, check to ensure that all connectors, coaxial cables, antennae and T1s are all properly connected; and that the system configuration ensures proper transmit and receive levels for the RF equipment. Then, if the problem persists, follow the actions recommended in this section. For further assistance, call ADTRAN Technical Support at (800) 726-8663.

NOTE

Each TRACER is completely system-tested and all specifications verified prior to shipment. Most problems on a new link tend to have installation-related solutions.

PROBLEM DESCRIPTIONS AND RECOMMENDED ACTIONS

Each problem described below is followed by a list of Possible Causes, each of which is followed by a number (or numbers) corresponding to a Recommended Action (or Actions).

IMPORTANT

If problems persist after you have followed the Recommended Actions, contact ADTRAN Technical Support at (800) 726-8663.

Troubleshooting using the front panel indicators

“Link Error” light is lit, or Link is Down

This alarm will activate when the RF link is not operational.

Possible Cause	Recommended Action (see list below)
• The RF link is down.	1-10
• The RX power is below the -91 dBm threshold (-90 dBm 5.8 GHz)..	1-4,7-10
• The far-end transmitter is off, or is transmitting low power	1-4,7-10
• The RF path is not aligned	1,2,10
• Water is in the antenna feedhorn or connectors	1,4
• Both units are set to the same frequency	5,10
• Both units are not set to the same PN code	6
• The connection between the BBP and the RFC is faulty.	1,7-10
• The connection between the RFC and the antenna is faulty.	1,7-10
• The BBP or RFC is faulty.....	10

Section 4 Troubleshooting

I M P O R T A N T

If problems persist after you have followed the Recommended Actions, contact ADTRAN Technical Support at (800) 726-8663.

Recommended Actions:

1. Check the RX power using the VT-100 user interface or RSSI voltage.
2. Check the far-end transmitter for operation and proper transmit power.
3. Check the RF path using a spectrum analyzer or RSSI voltages for proper alignment. Have path professionally re-aligned and check system path engineering.
4. Check the antenna feedhorn and all outdoor connections for water.
5. Verify same antenna polarity is used at both ends.
6. Change the frequency of one radio through the VT-100 user interface or front panel button.
7. Set both units to the same PN code.
8. Check all connections between the BBP, the RFC, and the antenna.
9. Check the IF and RF cables for shorts.
10. Check the connections inside the mastmount or rackmount RFC.
11. Replace the RFC.

“BPV” light on T1-A or B is lit

This alarm will activate when the incoming T1 stream presents BPVs.

Possible Cause	Recommended Action (see list below)
<ul style="list-style-type: none"> • The incoming T1 contains BPVs or errors. 1 • The line codes between DS1/DSX-1 equipment and the TRACER are incompatible. 2 	

Recommended Actions:

1. Check the incoming DS1/DSX-1 signal for BPVs using a T1 test set.
2. Correct the line code on the TRACER or DS1/DSX-1 equipment.

RED light on T1-A or B is lit

This alarm (Loss of Signal) will activate when there is no signal present at the T1 interface.

Possible Cause	Recommended Action (see list below)
<ul style="list-style-type: none"> • No DS1/DSX-1 signal or a degraded DS1/DSX-1 signal is present at the DS1/DSX-1 input. 1,2 • The connection at the T1 input or DS1/DSX-1 equipment is faulty. 2 	

Section 4 Troubleshooting

IMPORTANT

If problems persist after you have followed the Recommended Actions, contact ADTRAN Technical Support at (800) 726-8663.

Recommended Actions:

1. Verify the presence of a DS1/DSX-1 signal at the T1 monitor jack using a T1 test set.
2. Verify that all cables and connectors are correctly wired.

“LBK-A” or “LBK-B” is lit

This alarm will activate when a software or manual T1 loopback has been established.

Possible Cause

- A loopback has been commanded from the VT-100 user interface. 1,2
- The “LBK-A” or “LBK-B” button has been pressed. 1,2

Recommended Action (see list below)

Recommended Actions:

1. Through the VT-100 user interface, deactivate the loopback in the Loopback Menu.
2. Press the “LBK-A” or “LBK-B” button to deactivate the loopback.

“AIS/YEL” on T1-A or T1-B is lit

The AIS/YEL light will flash for AIS when the DS1/DSX-1 input receives a “blue code” (a string of 2316 1s with no more than one zero). The indicator will remain on (solid) if a YEL signal is present on the T1.

Possible Cause

- For AIS, the DS1/DSX-1 equipment is sending a “blue code” (all 1s) to the T1 input. 1,2
- For YEL, the received T1 is receiving a yellow signal from the far-end T1, indicating the far-end T1 is RED. 3-5

Recommended Action (see list below)

Recommended Actions:

1. Reset the T1 equipment and verify normal operation.
2. Verify the presence of a DS1/DSX-1 signal at the T1 monitor jack using a T1 test set.
3. Check the far-end equipment for alarms or a red condition.
4. Check the T1 connections at the far-end equipment.
5. Reset the far-end equipment.

Section 4 Troubleshooting

I M P O R T A N T

If problems persist after you have followed the Recommended Actions, contact ADTRAN Technical Support at (800) 726-8663.

“AIS/YEL” indicator is flashing

This alarm is activated when the T1 interface at the remote end is not receiving a T1 signal (it is in Red alarm). In this circumstance the interface with the flashing AIS/YEL indicator is transmitting an AIS (keep alive) signal.

Possible Cause	Recommended Action (see list below)
<ul style="list-style-type: none"> • No DS1/DSX-1 signal or a degraded DS1/DSX-1 signal is present at the DS1/DSX-1 input. 1,2 • The connection at the T1 input or DS1/DSX-1 equipment is faulty. 2 	

Recommended Actions:

1. Verify the presence of a DS1/DSX-1 signal at the T1 monitor jack using a T1 test set.
2. Verify that all cables and connectors are properly wired.

No “Power” Light

Possible Cause	Recommended Action (see list below)
<ul style="list-style-type: none"> • DC voltage is not applied. 1,2,4 • The polarity of the power connection is reversed. 2 • The AC transformer is not functioning properly. 3,4 • The AC transformer is not connected to the DC jack on the BBP, or not connected to AC outlet. 3,4 	

Recommended Actions:

1. Verify that the DC voltage is between 21-60 VDC (\pm).
2. Verify that negative voltage is applied to the negative terminal, and positive voltage applied to the positive terminal.
3. Verify that the “Power” light is lit on the AC transformer.
4. Verify that the AC transformer is connected to an AC power cord on the transformer, and connected to the DC jack on the BBP. Verify that the AC power cord is connected to an AC outlet. Verify that the AC outlet has proper AC voltage present.

Section 4 Troubleshooting

IMPORTANT

If problems persist after you have followed the Recommended Actions, contact ADTRAN Technical Support at (800) 726-8663.

“Test” light is lit or blinking

The test alarm will remain on (solid) during power-up, indicating a self-test is in progress. The light will flash or remain on (solid) if the self-test fails.

Possible Cause	Recommended Action (see list below)
• One-flash interval indicates a RAM test failure.	1
• Two-flash interval indicates the T1-C mux failed internal test.	1
• Three-flash interval indicates the T1-A framer failed.	1
• Four-flash interval indicates the T1-B framer failed.	1
• Five-flash interval indicates a DSP failure.	1
• On (solid) indicates a faulty internal component.	1

Recommended Actions:

1. Replace the BBP or the RFC.

“TST” light is lit after pressing “Remote Test” button

The Remote Test light will activate during a remote test in progress. The Remote Test performs a 10-second bit error rate test (BERT) over the RF link to the far-end.

Possible Cause	Recommended Action (see list below)
• A Remote Test has been activated from the front panel “Remote Test” button or the VT-100 user interface.	1

Recommended Actions:

1. Allow the remote test to complete. If the Remote Test Fail light does not activate, the remote test passed. If the Remote Test Fail light activates, see section on FAIL light is lit after pressing Remote Test button.

Section 4 Troubleshooting

I M P O R T A N T

If problems persist after you have followed the Recommended Actions, contact ADTRAN Technical Support at (800) 726-8663.

“Fail” light is lit after pressing “Remote Test” button

The Remote Fail light will activate after a Remote Test has failed.

Possible Cause	Recommended Action (see list below)
<ul style="list-style-type: none"> • The 10-second BERT has failed over the RF link to the far-end. 1 • The RX power may be below or near the -91 dbm threshold (-90 dBm 5.8 GHz) 1 	

Recommended Actions:

1. Check the RX power level using the VT-100 user interface or the RSSI DC voltage test points. Verify the RX power is between -55 and -91 dBm (-90 dBm 5.8 GHz).

“RF Low” light is on

This alarm will activate if the RX power is below -80 dbm.

Possible Cause	Recommended Action (see list below)
<ul style="list-style-type: none"> • The RX power is below -80 dBm. 1-5,7,8 • The far-end transmitter is off, or is transmitting low power. 2-5,7,8 • The RF path is not aligned. 3,8 • Water is in the antenna feedhorn or connectors. 4,8 	

Recommended Actions:

1. Verify the RX power is between -55 and -91 dBm (-90 dBm 5.8 GHz) using the VT-100 user interface or RSSI DC voltage test points.
2. Check the far-end transmitter for operation and proper transmit power.
3. Check the RF path using a spectrum analyzer or RSSI voltages for proper alignment. Have path professionally re-aligned and check system path engineering.
4. Check the antenna feedhorn and all outdoor connections for water.
5. Check all connections between the BBP, the RFC, and the antenna.
6. Check the IF and RF cables for shorts.
7. Check the connections inside the mastmount or rackmount RFC.
8. Replace the RFC.

I M P O R T A N T

If problems persist after you have followed the Recommended Actions, contact ADTRAN Technical Support at (800) 726-8663.

Troubleshooting Using the VT-100 User Interface

This section provides information for troubleshooting the Alarm Menu on the VT-100 user interface. The conditions present in the Alarm Menu are software indications and should match the front panel LED indications.

RED Alarm

This alarm will activate when there is no signal present at the T1 interface. This alarm is the same as a RED alarm on the front panel.

Possible Cause	Recommended Action (see list below)
<ul style="list-style-type: none"> No DS1/DSX-1 signal or a degraded DS1/DSX-1 signal is present at the DS1/DSX-1 input. 1,2 The connection at the T1 input or DS1/DSX-1 equipment is faulty. 2 	

Recommended Actions:

1. Verify the presence of a DS1/DSX-1 signal at the T1 monitor jack using a T1 test set.
2. Verify that all cables and connectors are correctly wired.

BPV Alarm

The BPV alarm will activate whenever the incoming T1 stream presents BPVs.

Possible Cause	Recommended Action (see list below)
<ul style="list-style-type: none"> The incoming T1 contains BPVs or errors. 1 The line codes between the DS1/DSX-1 equipment and the TRACER are incompatible. 2 	

Recommended Actions:

1. Check the incoming DS1/DSX-1 signal for BPVs using a T1 test set.
2. Correct the line code on the TRACER or DS1/DSX-1 equipment.

Section 4 Troubleshooting

IMPORTANT

If problems persist after you have followed the Recommended Actions, contact ADTRAN Technical Support at (800) 726-8663.

YEL/AIS Alarm

This alarm indicator will *flash* when a T1 Yellow alarm occurs. The indicator will remain on (solid) to indicate an AIS alarm when the DS1/DSX-1 is receiving a blue code (a string of 2316 1's with no more than 1 zero).

Possible Cause	Recommended Action (see list below)
<ul style="list-style-type: none"> The DS1/DSX-1 equipment is sending a “blue code” (all 1’s) to the T1 input. 	1,2
<ul style="list-style-type: none"> The far-end equipment is in a red condition and transmitting a yellow alarm. 	3-5

Recommended Actions:

1. Reset the upstream equipment and verify normal operation.
2. Verify the presence of a DS1/DSX-1 signal at the T1 monitor jack using a T1 test set.
3. Check the far-end equipment for alarms or a red condition.
4. Check the T1 connections at the far-end equipment.
5. Reset the far-end equipment.

RF Link Alarm or Code Sync Alarm

The RF Link Alarm will activate when the link is down or not operational. The Code Sync Alarm will activate when data synchronization has not been achieved between the RF link.

Possible Cause	Recommended Action (see list below)
<ul style="list-style-type: none"> The RF link is down. 	1-10
<ul style="list-style-type: none"> The RX power is below the -91 dbm threshold. 	1-4,7-10
<ul style="list-style-type: none"> The far-end transmitter is off, or is transmitting low power. 	1-4,7-10
<ul style="list-style-type: none"> The RF path is not aligned. 	1,3,10
<ul style="list-style-type: none"> Water is in the antenna feedhorn or connectors. 	1,4
<ul style="list-style-type: none"> Both units are set to the same frequency. 	5,10
<ul style="list-style-type: none"> Both units are not set to the same PN code. 	6
<ul style="list-style-type: none"> The connection between the BBP and the RFC is faulty. 	1,7-10
<ul style="list-style-type: none"> The connection between the RFC and the antenna is faulty. 	1,7-10
<ul style="list-style-type: none"> The BBP or RFC is faulty. 	10

Section 4 Troubleshooting

IMPORTANT

If problems persist after you have followed the Recommended Actions, contact ADTRAN Technical Support at (800) 726-8663.

Recommended Actions:

1. Check the RX power using the VT-100 user interface or RSSI voltage.
2. Check the far-end transmitter for operation and proper transmit power.
3. Check the RF path using a spectrum analyzer or RSSI voltages for proper alignment. Have path professionally re-aligned and check system path engineering.
4. Check the antenna feedhorn and all outdoor connections for water.
5. Verify both ends have same antenna polarization.
6. Change the frequency of one radio through the VT-100 user interface or front panel button.
7. Set both units to the same PN code.
8. Check all connections between the BBP, the RFC, and the antenna.
9. Check the IF and RF cables for shorts.
10. Check connections inside the mastmount or rackmount RFC.
11. Replace the RFC.

Carrier Sync Alarm or T1 Mux Framer Alarm

The Carrier Sync alarm will activate when frequency synchronization has not been achieved between the RF link. The T1 Mux Framer alarm will activate when synchronization between the T1 mux on each radio has not been achieved.

Possible Cause	Recommended Action (see list below)
• The RF link is down.	1-10
• The RX power is below the -91 dBm threshold (-90 dBm 5.8 GHz)..	1-4,7-10
• The far-end transmitter is off, or is transmitting low power.	1-4,7-10
• The RF path is not aligned.	1,3,10
• Water is in the antenna feedhorn or connectors.	1,4
• Both units are set to the same frequency.	5,10
• Both units are not set to the same PN code.	6
• The connection between the BBP and the RFC is faulty.	1,7-10
• The connection between the RFC and the antenna is faulty.	1,7-10
• The BBP or RFC is faulty.	10

Section 4 Troubleshooting

I M P O R T A N T

If problems persist after you have followed the Recommended Actions, contact ADTRAN Technical Support at (800) 726-8663.

Recommended Actions:

1. Check the RX power using the VT-100 user interface or RSSI voltage.
2. Check the far-end transmitter for operation and proper transmit power.
3. Check the RF path using a spectrum analyzer or RSSI voltages for proper alignment. Have path professionally re-aligned and check system path engineering.
4. Check the antenna feedhorn and all outdoor connections for water.
5. Verify both ends have same antenna polarization.
6. Change the frequency of one radio through the VT-100 user interface or front panel button.
7. Set both units to the same PN code.
8. Check all connections between the BBP, the RFC, and the antenna.
9. Check the IF and RF cables for shorts.
10. Check connections inside the mastmount or rackmount RFC.
11. Replace the RFC.

ES Values in T1 Status Menu

This value indicates the number of Errored Seconds in the T1 data stream.

Possible Cause	Recommended Action (see list below)
<ul style="list-style-type: none"> • In an AMI-coded T1, a BPV or frame bit error has occurred. • In an ESF-coded T1, a BPV or CRC error has occurred. 	<ul style="list-style-type: none"> 1 1

Recommended Actions:

1. Check the T1 signal with a BERT test set to determine origin of error.

SES Values in History Menu

This value indicates the number of Severely Errored Seconds in the T1 data stream.

Possible Cause	Recommended Action (see list below)
<ul style="list-style-type: none"> • In an AMI-coded T1, 1544 BPVs or 8 frame bit errors have occurred. • In an ESF-coded T1, 1544 BPVs or 320 CRC errors have occurred. 	<ul style="list-style-type: none"> 1 1

Recommended Action:

1. Check the T1 signal with a BERT test set to determine origin of error.

This section lists the specifications for the TRACER system.

Transmitter

Output Power +20 dBm, max, for 1 watt 2.4 GHz, factory setting is +27 dBm
Frequency Range 2400 to 2483.5 MHz, or 5725 to 5850 MHz
Channel Bandwidth 40 MHz (2.4 GHz) (two channels) or 62 MHz (5.8 GHz)
I/F 140 MHz

Receiver

Receive Level, range ... -30 to -91 dBm (-90 dBm, 5.8 GHz) (10^{-6} BER minimum)
Receive Level, maximum -30 dBm
Receive Level, nominal -60 dBm
IF 70 MHz

Frequency Plan

Plan A 2.4 GHz Tx 2.422 GHz, Rx 2.462 GHz
Plan B 2.4 GHz Tx 2.462 GHz, Rx 2.422 GHz
Plan A 5.8 GHz Tx 5747 GHz, Rx 5827 GHz
Plan B 5.8 GHz Tx 5827 GHz, Rx 5747 GHz

Spread Spectrum Data Pump

Modulation QPSK
Spreading Method Direct sequence
Code Length 120 bits
Processing Gain >12 dB
Number of Codes 10
Chipping Rate 12 times

Interface Specifications

Capacity 2 x T1
Connection RJ-48C, bantam
Line Code AMI, B8ZS
Framing SF, ESF
Alarms AIS, Red, Yellow, BPVs
Loopbacks Local and remote, per T1 channel

User Interface

Front Panel Alarm LEDs, Configuration Switches, Monitor Jacks
Diagnostics T1 Loopback, Remote Test with built-in BERT
Test Points RSSI, System Voltages, QPSK Constellation
VT-100 Terminal Menu-Driven User Interface, Control of the Remote End,
Password Protected (Optional), Event History

Section 5 Specifications

VT-100 Terminal Interface

Data Rate	9600 bps
Data Bits	8
Parity	None
Stop Bits	1
Terminal Emulation.....	VT-100

Mechanical & Environmental

Baseband Processor

Operating Temperature	-25°C to 65°C
Size	19" x 1.75" x 10.5"
Humidity	95%, Non-condensing
Weight	6 lbs.

Rack RFC

Operating Temperature	-40°C to 65°C
Size	19" x 1.75" x 11.5"
Humidity	95%, Non-condensing
Weight	6 lbs.

Mast Unit

Operating Temperature	-40°C to 65°C
Size	21" high x 9" diameter
Humidity	100%
Weight	18 lbs.

Power

Input Voltage	21 to 60 volts DC, either polarity referenced to ground
Power Consumption	30 watts
Connector	3 pin DIN (AC adapter), 3 pin screw clamp terminal block (DC)

SECTION 6 **WARRANTY, ORDERING AND RETURN**

WARRANTY

ADTRAN will replace or repair this product within five years from the date of shipment if it does not meet its published specifications or fails due to defects in materials and workmanship.

For detailed warranty, repair, and return information, refer to the ADTRAN Equipment Warranty, Repair, and Return Policy and Procedure located on the ADTRAN web site at <http://www.adtran.com>.

SALES

For TRACER sales information, contact Adtran Sales at:

(888) 3ADTRAN or <http://www.adtran.com/wireless>

TECHNICAL SUPPORT

Standard support hours are 7 a.m. to 7 p.m. CST, Monday through Friday. Emergency technical support is available 24 hours a day, seven days a week.

For technical support at any time, contact ADTRAN at:

(800) 726-8663

REPAIRS AND RETURNS

Return Material Authorization (RMA) is required prior to returning equipment to ADTRAN.

For RMA information, contact ADTRAN at:

(800) 726-8663

or ADTRAN, Inc.

Customer Service Department

P.O. Box 140000 / 901 Explorer Boulevard

Huntsville, Alabama 35814-4000

When returning faulty equipment, please include the RMA number on the shipping label.

61280003L2-1B

Section 6 Warranty, Ordering and Return Information

ACRONYMS USED IN THIS MANUAL

AMI	Alternate Mark Inversion
B8ZS	Bipolar 8 zero substitution
BER	Bit error rate
BBP	Baseband Processor
CRC	Cyclic Redundancy Check
DCE	Data Communications Equipment
DTE	Data Terminal Equipment
ESF	Extended superframe
FCC	Federal Communications Commission
FEC	Forward error correction
IF	Intermediate Frequency
ISM	Industrial, Scientific, and Medical
LBK	Loopback
QPSK	Quadrature Phase Shift Keying
RF	Radio frequency
RFC	Radio frequency converter
RSSI	Received signal strength indicator
Rx	Receive
SF	Superframe
Tx	Transmit

APPENDIX A CABLE CONNECTIONS

The cable connections required for various configurations are detailed below.

Terminal Connection (DB25)

<u>TRACER (DCE)</u>			<u>Terminal (DTE)</u>	
Number	Name		Number	Name
2	TXD	↔	2	TXD
3	RXD	↔	3	RXD
4	RTS	↔	4	RTS
5	CTS	↔	5	CTS
6	DSR	↔	6	DSR
7	Ground	↔	7	Ground

Personal Computer Connection (DB9)

<u>TRACER (DCE)</u>			<u>Computer (DTE)</u>	
Number	Name		Number	Name
2	TXD	↔	3	TXD
3	RXD	↔	2	RXD
4	RTS	↔	7	RTS
5	CTS	↔	8	CTS
6	DSR	↔	6	DSR
7	Ground	↔	5	Ground

Modem Connection (DB25)

<u>TRACER (DCE)</u>			<u>Modem (DCE)</u>	
Number	Name		Number	Name
2	TXD	↔	3	RXD
3	RXD	↔	2	TXD
4	RTS	↔	5	CTS
5	CTS	↔	4	RTS
6	DSR	↔	20	DTR
7	Ground	↔	7	Ground

Appendix A Cable Connections

TELEMETRY BYTE ORIENTED SERIAL (TBOS) MANAGEMENT CONNECTIONS (RJ48)

TBOS operates via RS422, therefore the inputs and outputs are differential pairs. The pinout for the MANAGEMENT IN port is:

- pin 1 - Transmit- (out of TRACER)
- pin 3 - Transmit+ (out of TRACER)
- pin 5 - Receive- (in to TRACER)
- pin 7 - Receive+ (in to TRACER)

The pinout for the MANAGEMENT OUT port is:

- pin 1 - Receive- (in to TRACER)
- pin 3 - Receive+ (in to TRACER)
- pin 5 - Transmit- (out of TRACER)
- pin 7 - Transmit+ (out of TRACER)

The rear panel connectors are on a double-stack RJ45, so the pin numbers are opposite of each other: A TBOS monitoring system will need to define the following bitmaps to indicate status and alarm conditions.

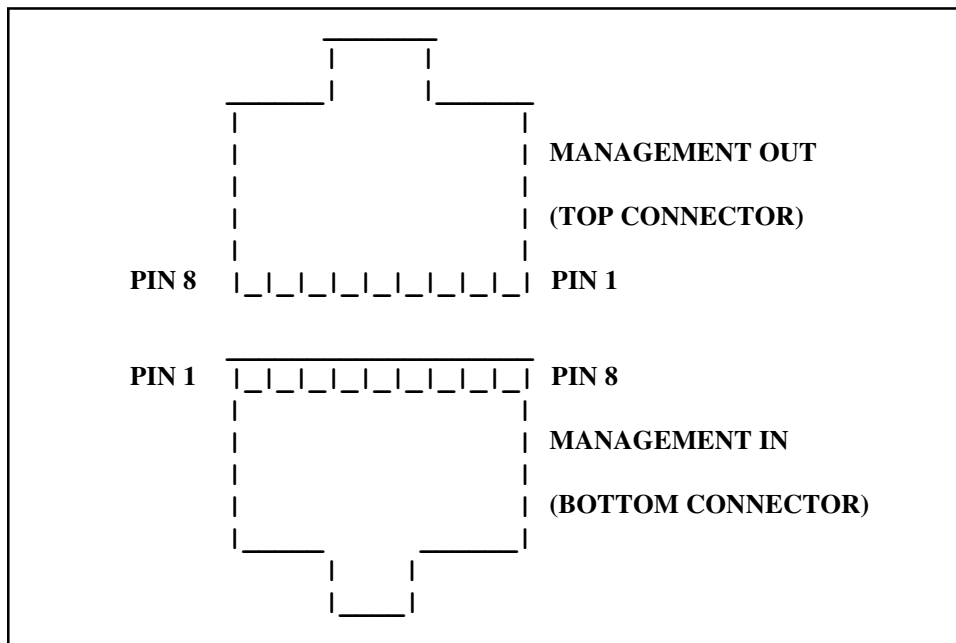

Figure 3-1. Rear Panel Connectors