

**ADURAN TRACER USER'S MANUAL**

---

## RADIO FREQUENCY INTERFERENCE STATEMENT

This equipment has been tested and found to comply with the limits for an intentional radiator, pursuant to Part 15, Subpart C of the FCC Rules. This equipment generates, uses, and can radiate radio frequency energy. If not installed and used in accordance with the instructions, it may cause interference to radio communications.

The limits are designed to provide reasonable protection against such interference in a residential situation. However, there is no guarantee that interference will not occur in a particular installation. If this equipment does cause interference to radio or television reception, which can be determined by turning the equipment on and off, the user is encouraged to try to correct the interference by one or more of the following measures:

- Reorient or relocate the receiving antenna of the affected radio or television.
- Increase the separation between the equipment and the affected receiver.
- Connect the equipment and the affected receiver to power outlets on separate circuits.
- Consult the dealer or an experienced radio/TV technician for help.

---

### W A R N I N G

---

Changes or modifications not expressly approved by ADTRAN could void the user's authority to operate the equipment.

---

## SHIELDED CABLES

A shielded-type power cord is required in order to meet FCC emission limits and also to prevent interference with nearby radio and television reception when using the AC voltage adapter. It is essential that only the Adtran-provided power cord be used.

## FCC OUTPUT POWER RESTRICTIONS

The FCC does not require licensing to implement this device. However, the FCC has established restrictions regarding maximum output power and the adjustments required when employing directional gain antennae. (Refer to "Setting the Transmitter Power" in Section 2 of this manual). These restrictions are detailed in FCC Part 15.247 (b)(1), (b)(3)(i), and (3)(iii). It is the responsibility of the individuals designing and implementing the radio system to assure compliance with these and any other pertinent FCC Rules and Regulations. This device must be professionally installed.

## EXPOSURE TO RADIO FREQUENCY FIELDS

This device is designed to provide a maximum power output of 100 mW. This level of RF energy in itself is below the Maximum Permissible Exposure (MPE) levels specified in FCC OET 65:97-01. The installation of high gain antenna equipment in the system configuration may create the opportunity for exposure to levels higher than recommended for the general population at a distance less than one meter from the center of the antenna. The following precautions must be taken during installation of this equipment:

- The installed antenna must not be located in a manner that allows exposure of the general population to the direct beam path of the antenna at a distance less than one meter. Installation on towers, masts, or rooftops not accessible to the general population is recommended; or
- Mount the antenna in a manner that prevents any personnel from entering the area within one meter from the front of the antenna
- During antenna installation, be sure that power to the Tracer equipment is turned *off* in order to prevent any energy presence on the coaxial connector.
- During installation and alignment of the antenna, do not stand in front of the antenna assembly.
- During installation and alignment of the antenna, do not handle or touch the front of the antenna.

These simple precautions must be taken to prevent general population and installation personnel from exposure to RF energy in excess of specified MPE levels.



# CONTENTS

---

	PAGE
<b>SECTION 1</b>	
<b>TRACER DESCRIPTION</b> .....	1
<b>INTRODUCTION</b> .....	1
<b>ISM BAND SPREAD SPECTRUM</b> .....	1
<b>APPLICATIONS</b> .....	2
<b>SPREAD SPECTRUM</b> .....	2
Direct Sequence .....	3
Coding .....	3
<b>CHANNEL SELECTION</b> .....	3
<b>FORWARD ERROR CORRECTION</b> .....	4
<b>T1 OPERATION</b> .....	4
Framing .....	4
Line Code .....	4
DS1/DSX-1 Interface .....	5
Line Buildout or LBO .....	5
<b>TRACER SYSTEM CONFIGURATION</b> .....	6
Baseband Processor or BBP .....	6
DS1/DSX-1 Interface .....	6
VT-100 RS-232 Interface .....	8
Alarm Contacts .....	8
IF Signal .....	8
AC/DC Power .....	9
Controls and Indicators .....	9
Radio Frequency Convertor or RFC .....	11
Antenna .....	13
<b>SECTION 2</b>	
<b>INSTALLATION</b> .....	15
<b>UNPACK, INSPECT</b> .....	15
<b>RACK-MOUNTED RFC CONFIGURATION</b> .....	15
<b>MAST-MOUNTED RFC CONFIGURATION</b> .....	15
<b>INSTALLATION</b> .....	16
<b>LOCATION</b> .....	16
<b>POWER REQUIREMENTS</b> .....	16
<b>GROUNDING</b> .....	16
<b>DS1/DSX-1 INTERFACE</b> .....	18

LINK PLANNING .....	19
ANTENNA FEEDLINE LOSS .....	20
ANTENNA GAIN .....	20
PATH LOSS .....	21
PATH AVAILABILITY .....	21
SETTING THE TRANSMITTER POWER .....	22
SETTING THE RFC FREQUENCY PLAN .....	23
CONNECTING THE BBP AND THE RFC .....	24
APPLYING POWER .....	25
SETTING THE BBP FREQUENCY PLAN .....	25
SPREADING CODE .....	25
CO-LOCATING MULTIPLE 2.4 GHz SYSTEMS .....	25
ANTENNA ALIGNMENT .....	26
RF LOW .....	27
REMOTE BERT .....	27
ALARM CONTACTS .....	27
SECTION 3 OPERATION .....	29
VT-100 USER INTERFACE .....	29
RS-232 INTERFACE .....	29
CABLE CONNECTIONS .....	29
PASSWORD .....	30
MAIN MENU SELECTIONS .....	31
SYSTEM STATUS PAGE .....	31
MAIN MENU PAGE .....	32
T1 STATUS PAGE .....	32
CHANNEL A STATISTICS PAGE .....	33
CHANNEL B STATISTICS PAGE .....	33
ALARM PAGE .....	34
TEST MENU .....	34
CONFIGURATION MENU .....	35

<b>SECTION 4</b>	<b>TROUBLESHOOTING .....</b>	<b>37</b>
	<b>GENERAL .....</b>	<b>37</b>
	<b>PROBLEM DESCRIPTIONS AND RECOMMENDED ACTIONS .....</b>	<b>38</b>
	<b>TROUBLESHOOTING USING THE FRONT PANEL INDICATORS .....</b>	<b>38</b>
	"Link Error" light is lit, or link is down .....	38
	"BPV" light on T1-A or B is lit .....	39
	RED light on T1-A or B is lit .....	39
	"LBK-A" or "LBK-B" is lit .....	40
	"AIS/YEL" on T1-A or T1-B is lit .....	40
	"AIS/YEL" indicator is flashing .....	41
	No "Power" light .....	41
	"Test" light is lit or blinking .....	42
	"TST" light is lit after pressing "Remote Test" button ..	42
	"Fail" light is lit after pressing "Remote Test" button ..	43
	"RF Low" light is on .....	43
	<b>TROUBLESHOOTING USING THE VT-100 USER INTERFACE ..</b>	<b>44</b>
	RED Alarm .....	44
	BLV Alarm .....	44
	YEL/AIS Alarm .....	45
	RF Link Alarm or Code Sync Alarm .....	46
	Carrier Sync Alarm or T1 Mux Framing Alarm .....	47
	ES Values in T1 Status Menu .....	48
	SES Values in History Menu .....	48
<b>SECTION 5</b>	<b>SPECIFICATIONS .....</b>	<b>49</b>
	<b>TRANSMITTER .....</b>	<b>49</b>
	<b>RECEIVER .....</b>	<b>49</b>
	<b>FREQUENCY PLANS .....</b>	<b>49</b>
	<b>SPREAD SPECTRUM DATA PUMP .....</b>	<b>49</b>
	<b>INTERFACE SPECIFICATIONS .....</b>	<b>50</b>
	<b>USER INTERFACE .....</b>	<b>50</b>
	<b>VT-100 TERMINAL INTERFACE .....</b>	<b>50</b>
	<b>MECHANICAL &amp; ENVIRONMENTAL .....</b>	<b>50</b>
	<b>POWER .....</b>	<b>51</b>
<b>SECTION 6</b>	<b>WARRANTY, ORDERING AND RETURN INFORMATION .....</b>	<b>53</b>
	<b>WARRANTY .....</b>	<b>53</b>
	<b>SALES .....</b>	<b>53</b>
	<b>REPAIRS AND RETURNS .....</b>	<b>53</b>
	<b>TECHNICAL SUPPORT .....</b>	<b>54</b>

**GLOSSARY** ..... 55  
**ACRONYMS USED IN THIS MANUAL** ..... 55

**APPENDIX A CABLE CONNECTIONS** ..... A-1  
**TERMINAL CONNECTION (DB25)** ..... A-1  
**PERSONAL COMPUTER CONNECTION (DB9)** ..... A-1  
**MODEM CONNECTION (DB25)** ..... A-2

**APPENDIX B FCC REGULATIONS** ..... B-1  
**AFFIDAVIT FOR CONNECTION OF CUSTOMER PREMISES  
EQUIPMENT TO 1.544 MBPS AND/OR SUBRATE  
DIGITAL SERVICES** ..... B-3



# ILLUSTRATIONS

---

1-1. Typical Application .....	2
1-2. Bandwidth Division .....	3
1-3. BBP .....	6
1-4. BBP Rear Panel .....	6
1-5. BBP Block Diagram .....	7
1-6. BBP Front Panel (with door closed) .....	9
1-7. BBP Front Panel (with door open) .....	9
1-8. RFC Module .....	11
1-9. RFC Function Block Diagram .....	12
1-10. Mast-Mount RFC Housing .....	13
1-11. Rack-Mount RFC Housing .....	13
2-1. Diplexer .....	23
3-1. System Status Page .....	31
3-2. Main Menu Page .....	32
3-3. T1 Status Page .....	32
3-4. Channel A Statistics Page .....	33
3-5. Channel B Statistics Page .....	33
3-6. Alarm Page .....	34
3-7. Test Menu .....	34
3-8. T1 Loopback Locations .....	35
3-9. Configuration Menu .....	35



## SECTION 1 **TRACER DESCRIPTION**

---

### **INTRODUCTION**

The Tracer provides dual T1 transport by way of a spread spectrum microwave link for distances up to 20 miles or more depending on path engineering. System performance is determined, in part, by the engineering of the microwave link. Each end of a Tracer link is composed of two units -- the baseband processor (BBP) and the radio frequency converter (RFC). Two DS1/DSX-1 (T1) interfaces are provided on the rear of the BBP, which can be mounted in a 19" rack. The DS1/DSX-1 interface provides connections up to 6000 feet from T1 equipment. A single coaxial cable connects the BBP to the RFC and another connects the RFC to the antenna.

### **ISM BAND SPREAD SPECTRUM**

The Federal Communications Commission (FCC) has established several portions of the radio frequency (RF) spectrum for use in Industrial, Scientific, and Medical (ISM) applications. Part 15.247 of the FCC rules describes the requirements of systems that operate in these bands. The three bands set aside, 902-928 MHz, 2400-2483.5 MHz, and 5725-5850 MHz, are designated for use by spread spectrum transmitters, either frequency hopping or direct sequence. The Tracer operates in the 2400 to 2483.5 MHz band using direct sequence spread spectrum (DSSS) transmission.

## APPLICATIONS

Any application that would typically use metallic T1 as a transport can use the Tracer instead. The figure below illustrates a typical application.

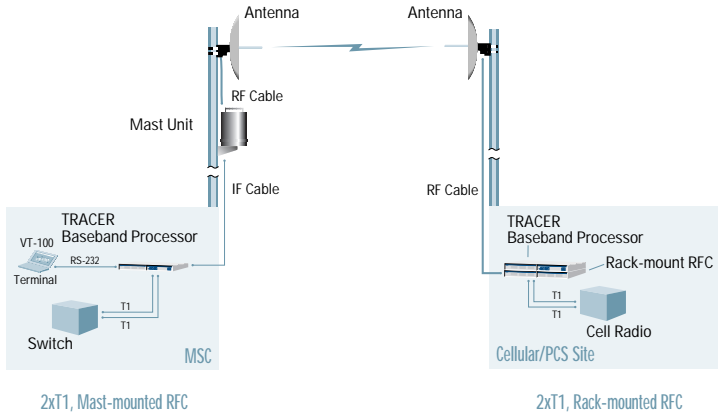

Mast and Rack mount RFCs may be mixed to accommodate individual system requirements.

Figure 1-1. Typical Application

The Tracer can be used in any application requiring that data be shared at a high rate of speed. In addition to telephony applications, Tracer can be used in data communications such as inter-networking, video conferencing, and telemetry.

## SPREAD SPECTRUM

Spread spectrum is a form of communication in which the bandwidth of a message signal is intentionally increased or "spread." The FCC rules allow two methods of spreading -- frequency hopping and direct sequence. Tracer employs direct sequence spread spectrum.

## DIRECT SEQUENCE

A direct sequence transmitter spreads the signal by mixing the data with the output of a pseudorandom number generator which changes state at a rate higher than the data rate. This rate is called the “chipping” rate. The Tracer chipping rate is twelve times the data rate.

## CODING

Many different pseudorandom sequences exist. The sequences are called pseudorandom because, although they appear noise-like, they are determinant and repeat after a specific number of chips. The longer a code is, the better correlation characteristics it possesses. These traits allow multiple spread spectrum systems to operate in the presence of one another with minimal interference if they are operating with different sequences. The Tracer allows the selection of one of ten different 120-bit long sequences.

## CHANNEL SELECTION

The FCC has allocated 83.5 MHz of spectrum in the band in which the Tracer operates. A Tracer system fully uses the available bandwidth -- transmitting in one half and receiving in the other. The figure below illustrates the bandwidth division.



Figure 1-2. Bandwidth Division

The transmitter at one end (TxA) of a link will transmit in the lower half of the spectrum. Consequently the receiver at the other end will receive in the lower half of the band and transmit in the upper half. Thus, a system will operate in one of two frequency plans -- transmit in the upper and receive in the lower or vice versa. These two plans are called Plan A and Plan B. One end of a path will be on Plan A and the other will be on Plan B. Shipment of a link will consist of an A and a B unless specified otherwise.

## **FORWARD ERROR CORRECTION**

With the addition of overhead data, error detection and correction capability can be added to a data stream. Error correction can be accomplished by allowing the receiver to request the re-transmission of an errored block once detected. The Tracer, on the other hand, implements forward error correction (FEC) which adds enough overhead data for the receiver to detect and correct errors in the data stream. This capability comes at the cost of bandwidth. The addition of FEC decreases the required signal-to-noise (S/N) ratio by approximately 5.5 dB to achieve a given bit error rate (BER).

## **T1 OPERATION**

### **FRAMING**

The data in a T1 stream is delimited by framing bits. The pattern of the framing bits follows one of two formats -- extended superframe (ESF) or superframe (SF). The T1 interface must be prepared for the format that will be used.

### **LINE CODE**

A mark in the data stream is coded as a pulse on the T1 line. A space is coded as "no activity" on the T1 line. As a form of error detection, subsequent marks in the data stream are coded as pulses of alternating polarity, either positive going or negative going. This type of line coding is called alternate mark inversion (AMI).

For the T1 receiver to operate correctly, a minimum number of "1s" must exist on the T1 facility. If the data cannot be guaranteed to meet this requirement, then another line coding format is used. In the bipolar 8 zero substitution (B8ZS) scheme, a string of eight "0s" is replaced by a special sequence of eight bits that contains a bipolar violation. The receiver, upon recognizing this sequence, reinserts the eight "0s" and the data is recovered intact.

### **DS1/DSX-1 INTERFACE**

When connecting the interface to the public switched network, an ADTRAN-provided cross-over cable (part number 3125.M011@A) is required to meet FCC part 68 and IC CS03 requirements. This cable is required to cross-over the Tx and Rx pairs to meet the connecting arrangement of a network interface device. This cable is included with the BBP and is labelled "T1 Crossover."

### **LINE BUILDOUT OR LBO**

The DS1/DSX-1 interface provides two different types of line buildouts (LBOs), respectively. When set for DS1, LBOs for 0 dB, -7.5 dB, -15 dB, and -22 dB are available. The DS1 interface can operate on line lengths up to 6,000 feet. When set for DSX-1 interface, LBOs for 0-133 feet, 266-399 feet, 399-533 feet, and 533-655 feet are available.

## Tracer SYSTEM CONFIGURATION

A Tracer system is composed of three major subsystems -- a baseband processor, a radio frequency convertor, and an antenna. The following section describes the system components.

### BASEBAND PROCESSOR OR BBP

The BBP (ADTRAN part number 1280.003L1) is a 1-U, 19" rack-mountable unit that provides the system electrical interfaces, user controls and indicators, and performs the spread spectrum processing for the system. The rear panel provides all of the electrical interface points -- DS1/DSX-1 interface, DS1/DSX-1 monitor, VT-100 terminal, alarm contacts, IF signal, DC power (from facility), and power (from AC adapter). The BBP and its rear panel are illustrated in the figures below.

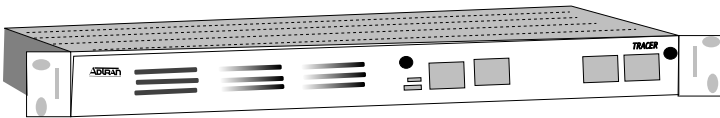

Figure 1-3. BBP

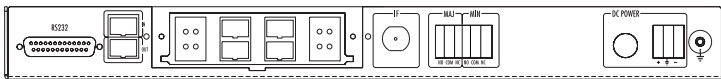

Figure 1-4. BBP Rear Panel

### DS1/DSX-1 INTERFACE

Two DS1/DSX-1 interfaces, labelled "T1A" and "T1B," are provided for connecting to the T1 equipment. Two types of physical interfaces are provided -- RJ-48C and bantam jacks.



The interfaces are illustrated in the BBP Block Diagram below. The functions of the BBP are partitioned into three printed circuit boards or PCBs, all contained in the same enclosure.

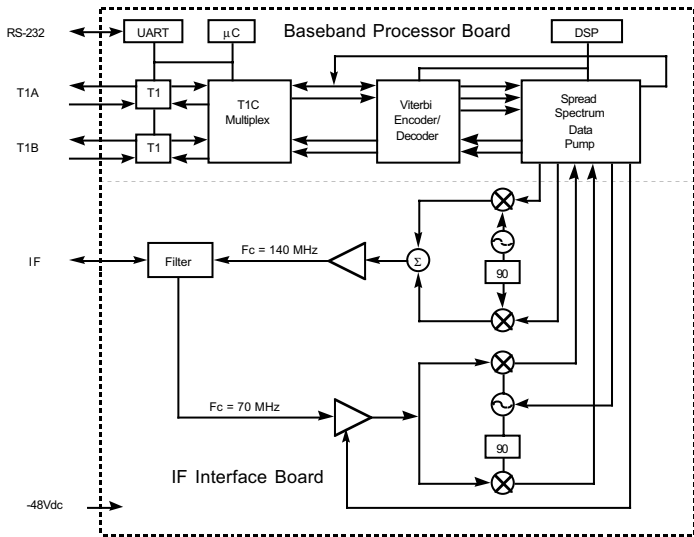

Figure 1-5. BBP Block Diagram

The DS1/DSX-1 interfaces provided for each channel are the same. The upper bantam connectors, labeled "Monitor," provide isolated monitor points for testing. The lower bantam jacks provide signal insertion points. The insertion of a bantam jack disconnects the RJ-48C connector from the circuit. The DS1/DSX-1 interface can operate on line lengths up to 6000 feet.

When connecting either T1 interface to the public switched network, an ADTRAN-provided cross-over cable (part number 3125.M011@A) is required to meet FCC part 68 and IC CS03 requirements. This cable is included with the BBP and is labelled "T1 Crossover." This cable is required to cross-over the TX and RX pairs to meet the connecting arrangement of a network interface device.

For connections to other CPE-type equipment, such as an ADTRAN TSU-100, a straight-through T1 cable is provided by ADTRAN (part number 3127.004) and is included with the BBP.

### **VT-100 RS-232 INTERFACE**

A serial interface port using RS-232C signal levels is provided for attaching a VT-100-compatible terminal. The connection is made via a DB-25 connector on the rear panel. The data rate is configured for 9600 bps, 8 data bits, no parity, and 1 stop bit.

### **ALARM CONTACTS**

Two sets of alarm contacts are provided on the rear of the BBP: major alarm and minor alarm. A major alarm indicates the radio link is not operational. A minor alarm indicates that system performance is degraded or that the T1 interfaces are experiencing errors. Normally-open and Normally-closed contacts are provided for both alarm types. Under normal operating conditions there is no continuity between the Normally-open and Common contacts, and, under an alarm condition, continuity between those contacts exists. The Normally-closed and Common contacts normally have continuity, while under alarm conditions, these contacts are open.

### **IF SIGNAL**

The N-type connector on the rear panel provides the interface point between the BBP and the RFC. This connection provides the data signal, power, and configuration information to the RFC. A coaxial cable (ADTRAN part number 3125.001@A) is provided for connecting the BBP to the RFC for the rack-mount model. Cable for connecting the BBP to a mast-mount RFC must be provided by the customer after the length of cable has been determined.

**AC/DC POWER**

The unit receives power via one of two connectors. Power for the entire system is provided by these interfaces. The three-pin circular DIN connector is provided to connect an optional ADTRAN desktop AC adapter (ADTRAN part number 1360.DSK24VL1), providing 24 volts DC. The three-pin terminal block allows the connection of any DC power source providing between 21 and 56 volts DC. The power consumption of the entire system is 30 watts.

**CONTROLS AND INDICATORS**

The system may be configured via the front panel, which is accessible behind a drop-down panel on the right half of the BBP. The front panel is illustrated in the figure below.

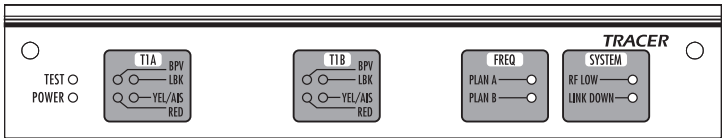

Figure 1-6. BBP Front Panel (with door closed)

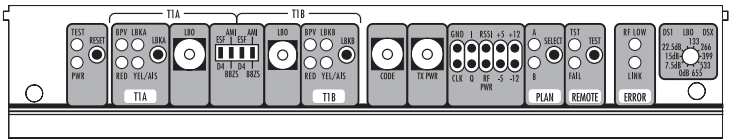

Figure 1-7. BBP Front Panel (with door open)

Options that are set from the front panel can be overridden via the terminal interface. As a rule, a green LED indicates a good situation, a red LED indicates an error situation, and a yellow LED indicates a configuration option. LEDs indicating overall system integrity are listed below.

- Test ..... Red indicates that the self-test has completed and failed
- PWR ..... Green indicates that DC voltage is applied

The LEDs associated with the DS1/DSX-1 interfaces are listed below. There are two sections of identical indicators -- one for each DS1/DSX-1 interface.

- BPV ..... Red if the incoming T1 stream contains bipolar violations
- RED ..... Red if there is no signal present at the T1 interface
- LPBK ..... Yellow if the T1 interface is in loopback
- YEL/AIS ..... Flashes to indicate a T1 Yellow Alarm; remains *On* (solid) to indicate an AIS alarm (when the DS1/DSX-1 is receiving a Blue code)

The LEDs indicating error conditions are listed below.

- RF Low ..... Red indicates the received RF carrier level is too low
- Link Down ..... Radio path is down

The front panel pushbutton controls are listed below.

- Reset ..... Reset the system
- LBKA ..... Toggles the T1-A between no loopback and line loopback
- LBKB ..... Toggles the T1-B between no loopback and line loopback
- Plan Sel ..... Toggles between frequency plans A and B (must match frequency plan cabling on RFC). Refer to "Setting the RFC Frequency Plan" in Section 2 of this manual.
- Remote Test ..... Initiate a remote test across the RF link

The monitor points provided on the front panel of the system are listed below

I .....	Demodulated received baseband output
Q .....	Demodulated received baseband output
CLK .....	Recovered clock for observing EYE pattern
RSSI .....	DC voltage indicating strength of the received signal at the antenna
+5 .....	System 5 volts
-5 .....	System -5 volts
+12 .....	System +12 volts
-12 .....	System -12 volts
RF PWR .....	Voltage supplying RF power
GND .....	System ground

### RADIO FREQUENCY CONVERTER OR RFC

The radio frequency converter or RFC (ADTRAN part number 1280.005L1) provides the RF interface between the BBP and the antenna.

The RFC module is illustrated in the figure below.

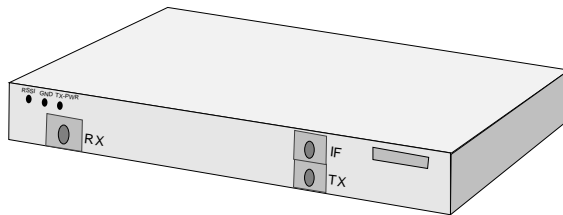

Figure 1-8. RFC Module

The RFC is partitioned, functionally, into two major components -- the transmitter and the receiver. It is partitioned physically into three printed circuit boards.

The major connections illustrated are the transmit signal, receive signal, and the IF signal connection.

The three SMA connectors located on the RFC module provide the transmitted RF, received RF, and IF connection points. Two test points are provided for monitoring the received signal strength indicator or RSSI. The voltage (relative to the GND test point) present on this test point represents the level of the received signal.

This signal is used to align the antenna during installation and to verify that the link is performing as designed. A third test point is provided to monitor the transmitter output power during system configuration.

The only connections that must be made in the field are a coax connection between the BBP and the RFC and a coax connection between the RFC and the antenna.

The “IF” connector provides the connection between the BBP and the rack or mast-mounted RFC. (A blue 6-inch IF cable [ADTRAN part number 3125.001@A] is provided for rack-mount systems. ADTRAN does not provide IF cable for mast-mount systems.) The “ANTENNA” connector provides the connection between the RFC and the antenna.

A block diagram of the RFC functions is shown in the figure below.

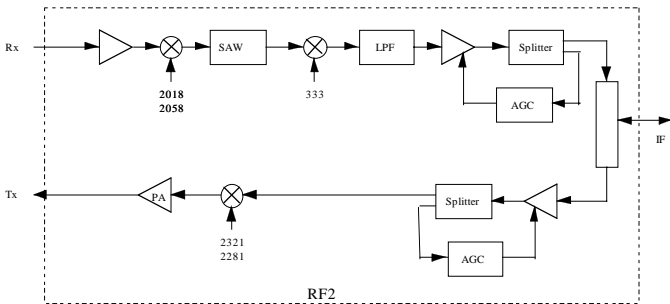

Figure 1-9. RFC Function Block Diagram

The RFC unit is enclosed in a metal housing measuring approximately 10.5" x 5.5" x 1" and may be mounted in a 1-U nineteen-inch rack space or in a weather-tight enclosure suitable

for mast-mounting near the antenna for enhanced system performance. The RFC mast-mount and rack-mount housings are illustrated below.

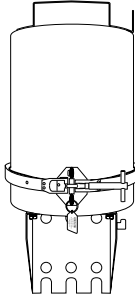

Figure 1-10. Mast-Mount RFC Housing

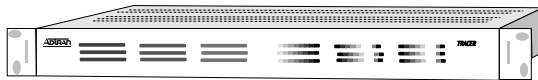

Figure 1-11. Rack-Mount RFC Housing

## ANTENNA

Tracer is intended to be coupled with an antenna that is directional and provides signal gain. There are several reasons for this requirement:

- Tracer operates in point-to-point applications; therefore, an omnidirectional antenna is not needed.
- The FCC provides no recourse in this band in the event of nearby interference, so a highly directional antenna reduces the likelihood of interference in the antenna pattern.
- The low power transmitter is intended to be used with a high-gain antenna for long links.

The antenna requirements are listed below.

Minimum gain .....	15 dBi
Minimum return loss .....	15 dB
Connector .....	N-type
Impedance .....	50Ω





## **RADIO FREQUENCY INTERFERENCE STATEMENT**

This equipment has been tested and found to comply with the limits for an intentional radiator, pursuant to Part 15, Subpart C of the FCC Rules. This equipment generates, uses, and can radiate radio frequency energy. If not installed and used in accordance with the instructions, it may cause interference to radio communications.

The limits are designed to provide reasonable protection against such interference in a residential situation. However, there is no guarantee that interference will not occur in a particular installation. If this equipment does cause interference to radio or television reception, which can be determined by turning the equipment on and off, the user is encouraged to try to correct the interference by one or more of the following measures:

- Reorient or relocate the receiving antenna of the affected radio or television.
- Increase the separation between the equipment and the affected receiver.
- Connect the equipment and the affected receiver to power outlets on separate circuits.
- Consult the dealer or an experienced radio/TV technician for help.

### **W A R N I N G**

Changes or modifications not expressly approved by ADTRAN could void the user's authority to operate the equipment.

## **SHIELDED CABLES**

A shielded-type power cord is required in order to meet FCC emission limits and also to prevent interference with nearby radio and television reception when using the AC voltage adapter. It is essential that only the Adtran-provided power cord be used.

## FCC OUTPUT POWER RESTRICTIONS

The FCC does not require licensing to implement this device. However, the FCC has established restrictions regarding maximum output power and the adjustments required when employing directional gain antennae. (Refer to “Setting the Transmitter Power” in Section 2 of this manual). These restrictions are detailed in FCC Part 15.247 (b)(1), (b)(3)(i), and (3)(iii). It is the responsibility of the individuals designing and implementing the radio system to assure compliance with these and any other pertinent FCC Rules and Regulations. This device must be professionally installed.

## EXPOSURE TO RADIO FREQUENCY FIELDS

This device is designed to provide a maximum power output of 100 mW. This level of RF energy in itself is below the Maximum Permissible Exposure (MPE) levels specified in FCC OET 65:97-01. The installation of high gain antenna equipment in the system configuration may create the opportunity for exposure to levels higher than recommended for the general population at a distance less than one meter from the center of the antenna. The following precautions must be taken during installation of this equipment:

- The installed antenna must not be located in a manner that allows exposure of the general population to the direct beam path of the antenna at a distance less than one meter. Installation on towers, masts, or rooftops not accessible to the general population is recommended; or
- Mount the antenna in a manner that prevents any personnel from entering the area within one meter from the front of the antenna
- During antenna installation, be sure that power to the Tracer equipment is turned *off* in order to prevent any energy presence on the coaxial connector.
- During installation and alignment of the antenna, do not stand in front of the antenna assembly.
- During installation and alignment of the antenna, do not handle or touch the front of the antenna.

These simple precautions must be taken to prevent general population and installation personnel from exposure to RF energy in excess of specified MPE levels.

## UNPACK, INSPECT

Carefully inspect the Tracer for any shipping damages. If damage is suspected, file a claim immediately with the carrier then contact ADTRAN Customer Service. If possible, keep the original shipping container for use in shipping the Tracer back for repair or for verification of damage during shipment.

Before beginning installation, verify that all of the following components are present.

### **RACK-MOUNTED RFC CONFIGURATION:**

Provided by ADTRAN --

- Baseband processor
- Rack-mounted RFC
- BBP to RFC IF interconnect cable
- DS1/DSX-1 interface cables (RJ-48 to RJ-48)

Provided by customer --

- Antenna feedline cable
- Antenna and mounting hardware
- VT-100 terminal and RS-232 interface cable (optional)
- 21 to 56 volt DC power source (available from ADTRAN), either polarity referenced to ground

### **MAST-MOUNTED RFC CONFIGURATION:**

Provided by ADTRAN --

- Baseband processor
- Mast-mounted RFC
- DS1/DSX-1 interface cables (RJ-48 to RJ-48)

Provided by customer --

- Antenna feedline cable
- Antenna and mounting hardware
- BBP to mast-mounted RFC IF interconnect cable
- VT-100 terminal and RS-232 interface cable (optional)
- 21 to 56 volt DC power source (available from ADTRAN), either polarity referenced to ground

## SECTION 2

**INSTALLATION****LOCATION**

Install the Tracer in a location that requires minimal antenna feedline length (the loss in this cable directly affects overall system performance). When the DS1/DSX-1 interface is configured for DS1 line buildouts, it can operate at lengths up to 6000 feet.

**POWER REQUIREMENTS**

The system power may be obtained from a DC power source if available, or an optional AC adapter available from ADTRAN. The Tracer can operate from a power supply between 21 and 56 volts DC, with either polarity referenced to ground, and consumes 30 watts of power.

**GROUNDING**

The following grounding instructions are derived from the Underwriters' Laboratory *UL 1459 Standard for Safety: Telephone Equipment* dated September 20, 1993.

An equipment grounding conductor that is no smaller in size than the ungrounded branch-circuit supply conductors is to be installed as part of the circuit that supplies the product or system. Bare, covered, or insulated grounding conductors are acceptable. Individually covered or insulated equipment grounding conductors shall have a continuous outer finish that is either green, or green with one or more yellow stripes. The equipment grounding conductor is to be connected to ground at the service equipment.

The attachment-plug receptacles in the vicinity of the product or system are all to be of a grounding type, and the equipment grounding conductors serving these receptacles are to be connected to earth ground at the service equipment.

A supplementary equipment grounding conductor shall be installed between the product or system and ground that is in addition to the equipment grounding conductor in the power supply cord.

The supplementary equipment grounding conductor shall not be smaller in size than the undergrounded branch-circuit supply conductors. The supplementary equipment grounding conductor shall be connected to the product at the terminal provided, and shall be connected to ground in a manner that will retain the ground connection when the product is unplugged from the receptacle. The connection to ground of the supplementary equipment grounding conductor shall be in compliance with the rules for terminating bonding jumpers at Part K or Article 250 of the National Electrical Code, ANSI/NFPA 70. Termination of the supplementary equipment grounding conductor is permitted to be made to building steel, to a metal electrical raceway system, or to any grounded item that is permanently and reliably connected to the electrical service equipment ground.

Bare, covered, or insulated grounding conductors are acceptable. A covered or insulated grounding conductor shall have a continuous outer finish that is either green, or green with one or more yellow stripes.

The supplemental equipment grounding terminals are located on the rear of the BBP adjacent to the power connectors and on the rear of the rack-mounted RFC.

## **DS1/DSX-1 INTERFACE**

The rear panel of the Tracer has two sets of jacks labeled T1A and T1B which provide the same functionality. The pin assignments for the eight-position modular jack are listed below.

Pin	Name	Function
1	R	Send data (ring)
2	T	Send data (tip)
3		Not used
4	R1	Receive data (ring)
5	T1	Receive data (tip)
6		Not used
7		Not used
8		Not used

Bantam jack connections are provided for test equipment access. Data is received on the jack labelled "IN" and is transmitted on the jack labelled "OUT." Bantam jacks are provided for both inserting and monitoring the interfaces. When a plug is placed in the insert jack, the connection between the modular jack and the

SECTION 2

interface circuitry is broken. The monitor jacks provide access to monitor the transmitted and received signals without interference.

When connecting either T1 interface to the public switched network, an ADTRAN-provided crossover cable (part number 3125.M011@A) is required to meet FCC part 68 and IC CS03 requirements. This cable is required to cross-over the Tx and Rx pairs to meet the connecting arrangement of a network interface device. This cable, labelled "T1 Crossover," is included with the BBP.

For connections to other CPE-type equipment, such as an ADTRAN TSU-100, a straight-through T1 cable (ADTRAN part number 3127.004) is included with the BBP.

Each DS1/DSX-1 interface must be configured for line code and framing, either from the front-panel rocker switches or via the VT-100 terminal. The choices for line code are AMI and B8ZS. The options for framing are SF and ESF. Each channel can be configured independently of the other and should be configured to match the attached T1 equipment.

The line build-out (LBO) must be set for each DS1/DSX-1 interface. The LBO setting allows each DS1/DSX-1 interface transmitter to drive the interface with the correct signal strength based on the line attenuation between Tracer and the attached equipment. The LBO is independently set for each interface via rotary switches on the front panel. Two sets of configurations are provided -- DSX-1 for short-haul interface (less than 655 feet) and DS1 for long-haul interfaces (greater than 655 feet). The settings are detailed below.

Interface Type	LBO	Switch Setting
DSX-1 .....	0-133 feet .....	2, 3
DSX-1 .....	133-266 feet .....	4
DSX-1 .....	266-399 .....	5
DSX-1 .....	399-533 .....	6
DSX-1 .....	533-655 feet .....	7
DS1 .....	0 dB .....	8
DS1 .....	-7.5 dB .....	9
DS1 .....	-15 dB .....	10
DS1 .....	-22.5 dB .....	11

**LINK PLANNING**

---

**IMPORTANT**

---

The appropriate transmitter power must be calculated as part of the link planning.

---

The factors that must be taken into account when planning a link are optimal received signal level, transmitter power, antenna feedline loss (each end), antenna gain (each end), free space path loss, and required fade margin.

---

**IMPORTANT**

---

The optimal signal level for the receiver is -60 dBm.

---

**ANTENNA FEEDLINE LOSS**

Feedline loss is a function of feedline type and length. Feedline loss per 100 feet for several types of coax at IF and RF frequencies is detailed in the table below. The IF loss applies to BBP/RFC interconnection, and the RF loss applies to RFC/antenna interconnection. Antenna manufacturers' specifications may vary.

Cable	IF Loss/100 feet (in dB)	RF Loss/100 feet (in dB)
RG58 .....	5.7 .....	80
RG8 (air) .....	2.7 .....	20
"Aircell" .....	2.4 .....	11.55
RG8 (foam) .....	2 .....	9
"Aircomm" .....	1.37 .....	6.55
1/4" Waveguide .....	1.42 .....	5.91
3/8" Waveguide .....	1.25 .....	5.76
1/2" Waveguide .....	0.81 .....	3.83
7/8" Waveguide .....	0.44 .....	2.2
1 1/4" Waveguide .....	0.33 .....	1.62
1 5/8" Waveguide .....	0.27 .....	1.41

### ANTENNA GAIN

Best performance will result from the use of a parabolic dish antenna. Antenna gain is determined by the size of the dish, with typical figures detailed below. Dish manufacturers will be able to supply gains for other types of antenna.

Dish Diameter (in feet)	Gain (in dBi)
2 .....	21
4 .....	27
6 .....	31
8 .....	33
10 .....	35
12 .....	37

### PATH LOSS

The free space path loss is given by

$$Loss(dB) = 96.6 + 20 \log_{10} f + 20 \log_{10} D$$

where

- D* is distance in miles
- f* is operating frequency in GHz

A tabulation of various path loss is given below.

Link Distance (in miles)	Path Loss (in dB)	Link Distance (in miles)	Path Loss (in dB)
1 .....	104	13 .....	126
2 .....	110	14 .....	127
3 .....	114	15 .....	128
4 .....	116	16 .....	128
5 .....	118	17 .....	129
6 .....	120	18 .....	129
7 .....	121	19 .....	129
8 .....	122	20 .....	130
9 .....	123	21 .....	130
10 .....	124	22 .....	131
11 .....	125	23 .....	131
12 .....	126	24 .....	132



## PATH AVAILABILITY

The availability of a path can be expressed by:

$$\text{availability} = (1 - C \times T \times 2.5 \times 10^{-6} \times f \times D^3 \times 10^{-F/10}) \times 100\%$$

where

$C$  is the climate factor

$T$  is the terrain factor

$f$  is the frequency in GHz

$D$  is the path length in miles

$F$  is the fade margin in dB

Climate factors are given below.

Climate	Climate Factor
Very Dry .....	$\frac{1}{8}$
Temperate .....	$\frac{1}{4}$
Humid .....	$\frac{1}{2}$

Terrain factors are listed below

Terrain	Terrain Factor
Smooth .....	4
Average .....	1
Mountainous .....	$\frac{1}{4}$

The nominal received signal level is -60 dBm. For help in link planning, use the path loss calculation worksheet below.

- 91 dBm	Minimum Signal Power
+ _____	Transmitter Feedline Loss
- _____	Transmitter Antenna Gain
+ _____	Path Loss
- _____	Receiver Antenna Gain
+ _____	Receiver Feedline Loss
+ _____	Required Fade Margin
= _____	(dBm) Transmitter Power Setting

## SETTING THE TRANSMITTER POWER

The FCC specifies the maximum transmitter power that may be used for antennae of a given gain. FCC rules Part 15, Subpart 247 allow for a maximum power of 1 watt into antennae of a gain less than or equal to 6 dBi. For every 3 dB of gain over 6 dBi, the transmitter must be reduced by 1 dB. The following table lists the maximum transmitter power for given antennae gains.

Antenna	
Gain	Power
6 dBi .....	30 dBm
12 dBi .....	28 dBm
18 dBi .....	26 dBm
24 dBi .....	24 dBm
30 dBi .....	22 dBm
36 dBi .....	20 dBm (Tracer's maximum power output)

The transmitter power is set by way of a potentiometer on the front panel of the BBP or via the configuration page of the interface VT-100. The RFC must be attached by way of the IF cable during this operation. Attach an RF power meter to the N-type antenna connector on the RFC, and adjust the power by way of the potentiometer or VT-100 until the desired transmitter power is obtained. For convenience, the transmitter power adjustment should be made before the RFC is installed on the mast.

## SETTING THE RFC FREQUENCY PLAN

The frequency plan designates on which frequencies the Tracer transmits and receives. Plan A corresponds to a transmitting (Tx) frequency of 2422 MHz and a receive (Rx) frequency of 2462 MHz. Plan B corresponds to a Tx frequency of 2462 MHz and a Rx frequency of 2422 MHz. Shipment of a link consists of one RFC set to Plan A and the other set to Plan B unless specified otherwise. The RFC plan can, however, be changed in the field if required. This procedure involves two steps:

- Configuring the RFC interconnect
- Informing the BBP of the correct Plan

To reconfigure the RFC interconnect, do the following:

1. Remove the four screws which retain the RFC cover and remove the cover.
2. The RF unit may be identified by following the connection from the port labelled “IF” on the rear of the RFC. This connection terminates at the RF unit. The diplexer may be identified by following the connection from the “Antenna” port on the rear of the RFC. This connection terminates at the circulator, which in turn is connected to the diplexer, illustrated in the figure below.

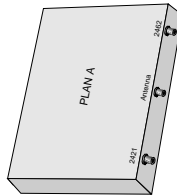

Figure 2-1. Diplexer

3. Unscrew the cable assemblies from the ports labelled “Tx” and “Rx” on the RFC, and the ports labelled “2422” and “2462” on the diplexer, depending on the frequency Plan (Plan A or Plan B).
4. Unscrew the cable assembly from the port labelled “Antenna” on the diplexer.
5. Remove the four screws from the bottom of the RFC that hold the diplexer in place.
6. Turn the diplexer over revealing the opposite frequency plan (from Plan A to Plan B, or vice versa).
7. Realign the diplexer with the screw holes and replace the four screws that attach it to the bottom of the RFC.
8. Re-attach the loose cable assembly (from step 4) to the port labelled “Antenna” on the diplexer.

## SECTION 2

9. Re-attach the cable assemblies from the ports labelled “Tx” and “Rx” on the RFC, and the ports labelled “2422” and “2462” on the diplexer. Cable connections should be aligned to each other as follows.

Plan A

Tx = 2422

Rx = 2462

Plan B

Tx = 2462

Rx = 2422

10. Replace and secure the RFC cover.

## CONNECTING THE BBP AND THE RFC

The BBP and the RFC are connected by an IF cable, either supplied by ADTRAN (for rack-mount assembly) or by the customer (for mast-mount assembly). This single connection provides everything the RFC requires. The cable assembly attaches to the ports labeled “IF” on the BBP and the RFC.

## APPLYING POWER

If the ADTRAN-supplied tabletop power source is used, simply plug it into the circular receptacle located in the “DC Power” area on the rear of the BBP. If a source of 21 to 56 volts DC (30 watts), either polarity referenced to ground, is available, it may be attached to the terminal block located on the rear of the BBP. The positive lead should be attached to the “+” side of the block and the negative lead should be attached to the “-” side of the block.

---

### CAUTION

---

Power sources must not be attached to both the circular connector and the terminal blocks at the same time or damage will occur.

---

## SETTING THE BBP FREQUENCY PLAN

Upon the initial application of power, the BBP will default to the factory-preset Frequency Plan, or to the Frequency Plan in use when the unit was last powered-down. The BBP attached to the RFC configured for Plan B must be set to Plan B by pressing the “Plan” switch on the front panel. The LED will indicate which frequency plan is active. On subsequent reboots, such as after a loss of power, the BBP will default to the most recently-used Plan setting.

## SPREADING CODE

The spreading code for each end must be the same. The choice of operating code is selectable by the operator or the installer. Tracer is shipped in a matched (default) configuration.

---

### WARNING

---

It is possible for the spreading code to be changed remotely through the VT-100 interface from the other end of the link. When this is performed, communications will be lost to the far end. The spreading code will change to code “0” and communications will be lost as soon as this change is made. If this happens, set the Spreading Code on the local unit to code “0”. The units should regain communications as soon as the correct code is selected.

---

## CO-LOCATING MULTIPLE 2.4 GHz SYSTEMS

When multiple 2.4 GHz transmitters are to be co-located (installed in the same equipment room or on the same tower), it is advised to set all systems as follows:

1. If more than one 2.4 GHz system is transmitting from the same location, set the antenna polarity of one system *horizontal* and the other system(s) *vertical*. (The antennas should be marked as to which mounting position is vertical or horizontal.) This will provide approximately 30 dB of isolation between the different antennas.
2. If more than one Tracer system is installed, set the co-located transmitters to the same frequency plan (example: Plan A, Tx=2422; or Plan B, Tx=2462) and set each to a different spreading code. This keeps the transmitters on the additional system(s) from interfering with the co-located receiver(s).

## SECTION 2

3. If the systems are from different manufacturers, set the transmit frequencies as close as possible with different spreading codes. Other manufacturers may not use the exact frequency plans as the Tracer system, but keeping the frequencies close will reduce the probability of the transmitter(s) interfering with the co-located receiver(s).

This equipment is authorized under CFR 47 Part 15.247. With this authorization by the FCC, this equipment shall not be co-located with a similar transmitter that transmits identical information.

## ANTENNA ALIGNMENT

After the transmitter power for each end has been adjusted and the BBP and RFC have been installed and connected, the antenna should be connected to the RFC via the feedline. The antennas should be aimed toward one another as precisely as possible and the received signal strength indicator (RSSI) voltage measured. The RSSI voltage is a function of the signal strength at the receiver and is used to measure the received signal strength. RSSI varies approximately from 0 to 4 volts, with 0 volts corresponding to a weaker received signal and 4 volts corresponding to a stronger received signal.

## RF Low

The “RF Low” LED indicates that the received signal is within 10dB of the minimum received signal strength (~-80 dBm). If this indicator is on, the link performance may be marginal. The antennas should be peaked in azimuth and elevation until the desired signal level is achieved. RSSI may be monitored on either the RF unit or the front of the BBP. If the received signal is too strong and RSSI reaches a maximum such that the peak cannot be discerned, then the transmitter on the far end should be turned down.

At this point the radio link should be operational. Proper operation can be determined by the status of the “LINK ERR” LED. If this LED is *on*, the link is *not* operational. If this LED is not on, the link is operating. Certain types of interference can cause one end of a path to operate and the other end to fail. In some instances, this may be corrected by swapping the frequency plan at each end, thus avoiding the interference if it is stronger at one end

than the other. Changing the spreading code at each end may also allow interference to be mitigated.

## **REMOTE BERT**

The Tracer includes a Bit Error Rate Tester (BERT) to verify that the installed system is operating correctly. When the “Remote Test” button is pushed on the local BBP, the remote end will send a BERT pattern for approximately ten seconds. The “Remote TST” indicator will turn yellow and remain on for the duration of the test. If no bit errors are detected, the “Remote TST” indicator will turn off. If any bit errors are detected, the “Remote Fail” indicator will turn red. This test should be run after the radio link has been aligned. If the test fails, refer to Section 4, “Troubleshooting,” for guidance.

## **ALARM CONTACTS**

Two sets of alarm contacts are provided on the rear of the BBP: major alarm and minor alarm. A major alarm indicates the radio link is not operational. A minor alarm indicates that system performance is degraded or that the T1 interfaces are experiencing errors. Normally-open and Normally-closed contacts are provided for both alarm types. Under normal operating conditions there is no continuity between the Normally-open and Common contacts and under an alarm condition continuity between those contacts exists. The Normally-closed and Common contacts normally have continuity, while under alarm conditions, these contacts are open.





### **VT-100 USER INTERFACE**

The Tracer may be accessed with a VT-100 compatible terminal set to 9600 bits per second, 8 data bits, and no parity, connected to the RS-232 port on the back of the unit. Once a terminal is connected, pressing the ESC key will present the System Status screen. If password access has been enabled, then press "Enter" or "Return" in order to see the "Enter Password:" message. Tracer is shipped with password protection disabled.

### **RS-232 INTERFACE**

The Tracer has an RS-232 interface for system management via an attached VT-100 terminal, personal computer, or modem. The RS-232 port is configured as a DCE with the following pin assignments:

Signal Name	Pin Number	Direction
TXD .....	2 .....	To Tracer
RXD .....	3 .....	From Tracer
RTS .....	4 .....	To Tracer
CTS .....	5 .....	From Tracer
DSR .....	6 .....	From Tracer
Ground .....	7	

### **CABLE CONNECTIONS**

The cable connections required for various configurations are detailed in Appendix A of this manual.

**PASSWORD**

Tracer provides optional password protection of the terminal interface. If enabled, a password prompt is presented at power-up, reboot, or after thirty minutes of inactivity on the terminal. The default configuration is “No password.” Password protection is enabled via the configuration menu. The password is also set via the configuration menu.

If the password is forgotten, physical access to Tracer is required to access the terminal interface. The password may be bypassed by holding in the LPBK A button while the system is rebooted. This will bring up the terminal interface and allow the password to be changed or disabled via the configuration screen.

---

**CAUTION**

---

**This procedure is service-affecting.**

---

## MAIN MENU SELECTIONS

### SYSTEM STATUS PAGE

This page displays the status of major system components. This is a status screen only; no configurations can be performed. More detailed information can be obtained by way of the Main Menu.

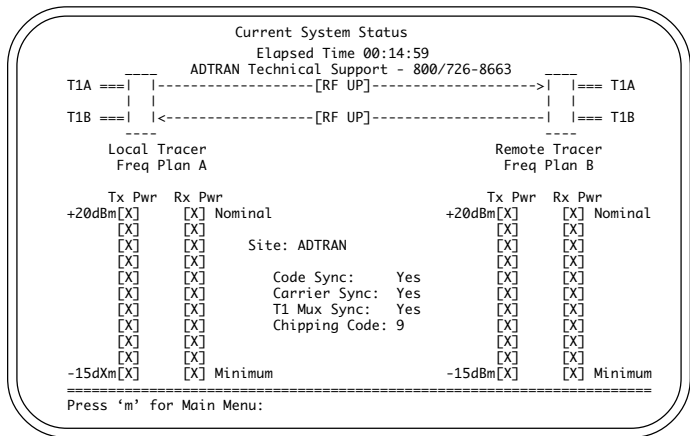

Figure 3-1. System Status Page

The upper portion of the screen indicates how long the system has been running since the last reset operation. The “T1A” and “T1B” labels will be highlighted if any error conditions exist on that T1 interface.

The status of the radio link is indicated as Up or Down. The left portion of the screen reports the status of the local system (the system to which the terminal is attached); the right portion reports the status of the remote system. The approximate transmitter and receiver signal levels are shown via the “fuel gauges.” If the link is down and remote end data is unavailable, the fuel gauges will show “-” instead of “x.” The Code Sync, Carrier Sync, and T1 Mux Sync will all be “yes” for an operational link. Chipping code indicates the code to which the system is set. At any point in the VT-100 menu structure, pressing the Escape key will bring the operator back to this screen.

## MAIN MENU PAGE

Pressing “M” on any screen will take the user to the Main Menu, from which the subsequent screens can be accessed.

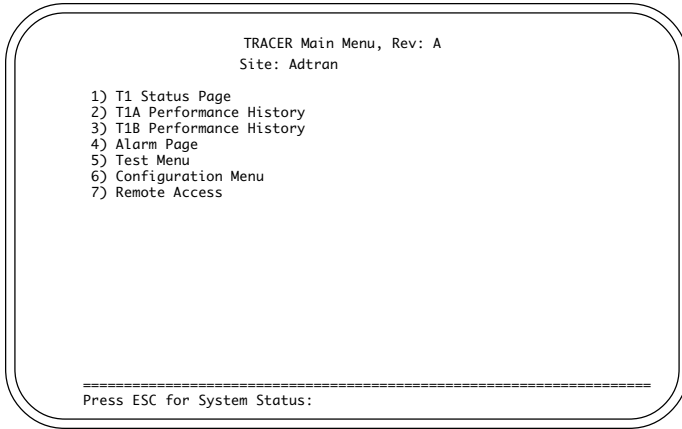

Figure 3-2. Main Menu Page

## T1 STATUS PAGE

The status of the two T1 interfaces is displayed on this screen. Information such as alarm status, T1 receive levels, line coding, and framing type are shown. This is a status screen only.

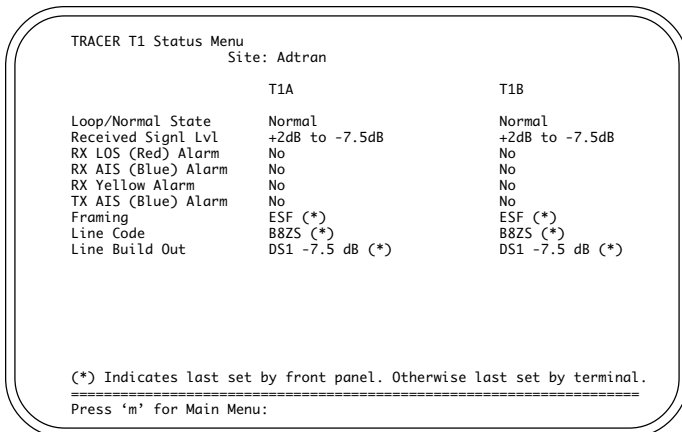

Figure 3-3. T1 Status Page

## CHANNEL A STATISTICS PAGE

This screen presents detailed error statistics for T1A. The data is presented as Errored Seconds and Severely Errored Seconds. The counts for the most recent 24 hours are recorded in 15-minute increments. Twenty-four-hour totals are recorded for the most recent days.

TRACER T1A Performance History			
Site: Adtran			
24 Hour Registers		15 Minute Registers	
--ES--SES--		--ES--SES-----ES--SES-	
0000 00000	<- Current ->	000 000	
-1: -----		-1: 000 000	-17: --- --
-2: -----		-2: --- --	-18: --- --
-3: -----		-3: --- --	-19: --- --
-4: -----		-4: --- --	-20: --- --
-5: -----		-5: --- --	-21: --- --
-6: -----		-6: --- --	-22: --- --
-7: -----		-7: --- --	-23: --- --
		-8: --- --	-24: --- --
		-9: --- --	-25: --- --
		-10: --- --	-26: --- --
		-11: --- --	-27: --- --
		-12: --- --	-28: --- --
		-13: --- --	-29: --- --
		-14: --- --	-30: --- --
		-15: --- --	-31: --- --
		-16: --- --	-32: --- --

=====  
Press 'm' for Main Menu:

Figure 3-4. Channel A Statistics Page

## CHANNEL B STATISTICS PAGE

This screen presents detailed error statistics for T1B. The data is presented as Errored Seconds and Severely Errored Seconds. The counts for the most recent 24 hours are recorded in 15-minute increments. Twenty-four-hour totals are recorded for the most recent days.

TRACER T1B Performance History			
Site: Adtran			
24 Hour Registers		15 Minute Registers	
--ES--SES--		--ES--SES-----ES--SES-	
00000 00000	<-- Current -->	000 000	
-1: -----		-1: 000 000	-17: --- --
-2: -----		-2: --- --	-18: --- --
-3: -----		-3: --- --	-19: --- --
-4: -----		-4: --- --	-20: --- --
-5: -----		-5: --- --	-21: --- --
-6: -----		-6: --- --	-22: --- --
-7: -----		-7: --- --	-23: --- --
		-8: --- --	-24: --- --
		-9: --- --	-25: --- --
		-10: --- --	-26: --- --
		-11: --- --	-27: --- --
		-12: --- --	-28: --- --
		-13: --- --	-29: --- --
		-14: --- --	-30: --- --
		-15: --- --	-31: --- --
		-16: --- --	-32: --- --

=====  
Press 'm' for Main Menu:

Figure 3-5. Channel B Statistics Page

### ALARM PAGE

This screen presents alarm information for the system. The T1A or T1B alarms are described in the chapter entitled “Troubleshooting.” If any of the T1A or T1B alarms are active, a minor alarm will be indicated at the alarm contacts. The RF link alarm will be activated when communication between the BBP and the RFC has failed. Code Sync, Carrier Sync, and T1 Mux Framer alarms indicate that various portions of the spread spectrum data pump are not operating. Any of these alarms will cause a major alarm to be activated at the alarm contacts.

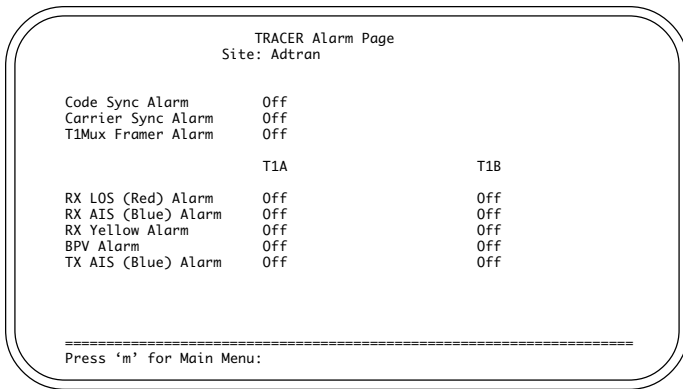

Figure 3-6. Alarm Page

### TEST MENU

This screen allows each T1 to be put into loopback mode.

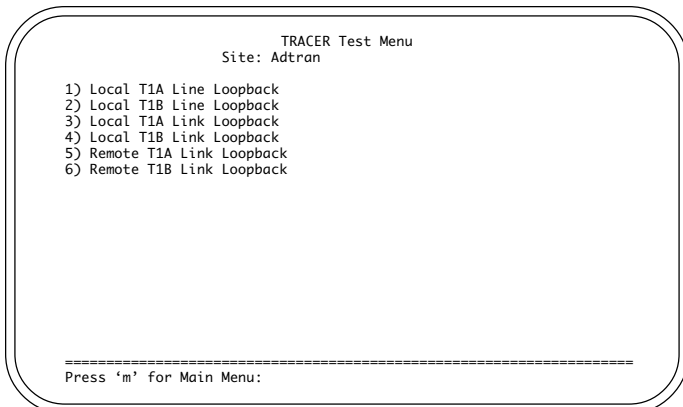

Figure 3-7. Test Menu

Each menu selection is described below:

1. Loops the local T1-A Interface towards the local customer equipment.
2. Loops the local T1-B Interface towards the local customer equipment.
3. Loops the local T1-A interface towards the remote customer equipment, over the RF Link.
4. Loops the local T1-B interface towards the remote customer equipment, over the RF Link.
5. Loops the remote T1-A Interface towards the local customer equipment, over the RF Link.
6. Loops the remote T1-B Interface towards the local customer equipment, over the RF Link.

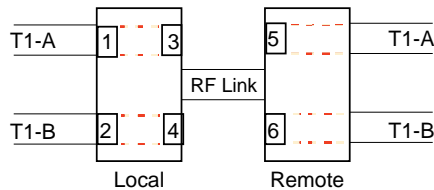

Figure 3-8. T1 Loopback Locations

## CONFIGURATION MENU

This screen allows all system configurations to be performed.

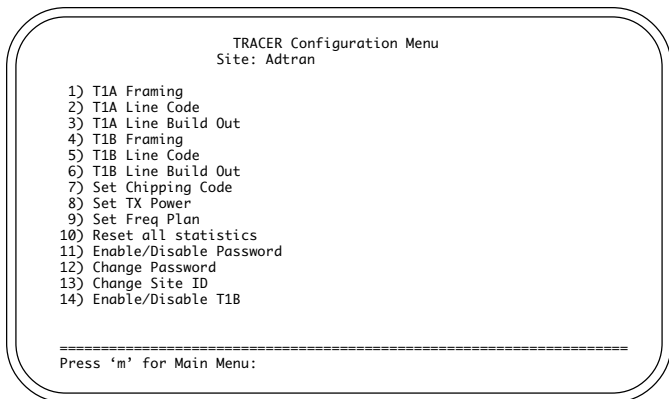

Figure 3-9. Configuration Menu

The menu selections are described below.

**T1A and T1B Framing** allow each T1 to be configured for SF or ESF framing.

**T1A and T1B Line Code** allow each T1 to be configured for AMI or B8ZS.

**T1A and T1B Line Buildout** allow each T1 to be configured for the appropriate line buildout, based on the distance to the T1 equipment.

---

W A R N I N G

---

It is possible for the spreading code to be changed remotely through the VT-100 interface from the other end of the link. When this is performed, communications will be lost to the far end. The spreading code will change to code "0" and communications will be lost as soon as this change is made. If this happens, set the Spreading Code on the local unit to code "0." The units should regain communications as soon as the correct code is selected.

---

**Set Chipping Code** allows the chipping code to be selected. Each end of the link must be configured for the same chipping code.

**Set Tx Power** allows the transmitter power to be adjusted.

**Set Freq Plan** allows the frequency plan to be set to A or B. One end of a link must be set to A and the other set to B. The setting of the BBP must match the attached RFC. For further information, see "Setting the RFC Frequency Plan" in the "Installation" chapter of this manual.

**Reset All Statistics** resets all the error counters.

**Enable/Disable Password** allows password protection to be enabled or disabled. The default setting is Disabled.

**Change Password** allows the password to be set.

**Site ID** allows a string of up to 32 characters to be entered as a site identifier.



## SECTION 4 **TROUBLESHOOTING**

---

### **GENERAL**

If you experience a problem with the Tracer system, check to ensure that all connectors, coaxial cables, antennae and T1s are all properly connected; and that the system configuration ensures proper transmit and receive levels for the RF equipment. Then, if the problem persists, follow the actions recommended in this section. For further assistance, call ADTRAN Technical Support at (800) 726-8663.

---

#### **NOTE**

---

**Each Tracer is completely system-tested and all specifications verified prior to shipment. Most problems on a new link tend to have installation-related solutions, but in some cases, the equipment may be at fault.**

---

### PROBLEM DESCRIPTIONS AND RECOMMENDED ACTIONS

Each problem described below is followed by a list of Possible Causes, each of which is followed by a number (or numbers) corresponding to a Recommended Action (or Actions).

**— I M P O R T A N T —**

**If problems persist after you have followed the Recommended Actions, contact ADTRAN Technical Support at (800) 726-8663.**

### TROUBLESHOOTING USING THE FRONT PANEL INDICATORS

#### **“LINK ERROR” LIGHT IS LIT, OR LINK IS DOWN**

This alarm will activate when the RF link is not operational.

<b>POSSIBLE CAUSE</b>	<b>RECOMMENDED ACTION (SEE LIST BELOW)</b>
• The RF link is down. ....	1-10
• The RX power is below the -91 dbm threshold. ....	1-4,7-10
• The far-end transmitter is off, or is transmitting low power.....	1-4,7-10
• The RF path is not aligned. ....	1,2,10
• Water is in the antenna feedhorn or connectors. ....	1,4
• Both units are set to the same frequency. ....	5,10
• Both units are not set to the same PN code. ....	6
• The connection between the BBP and the RFC is faulty. ....	1,7-10
• The connection between the RFC and the antenna is faulty. ....	1,7-10
• The BBP or RFC is faulty. ....	10

#### **RECOMMENDED ACTIONS:**

1. Check the RX power using the VT-100 user interface or RSSI voltage.
2. Check the far-end transmitter for operation and proper transmit power.
3. Check the RF path using a spectrum analyzer or RSSI voltages for proper alignment. Have path professionally re-aligned and check system path engineering.
4. Check the antenna feedhorn and all outdoor connections for water.
5. Change the frequency of one radio through the VT-100 user interface or front panel button.
6. Set both units to the same PN code.

---

**I M P O R T A N T**

---

If problems persist after you have followed the Recommended Actions, contact ADTRAN Technical Support at (800) 726-8663.

---

7. Check all connections between the BBP, the RFC, and the antenna.
8. Check the IF and RF cables for shorts.
9. Check the connections inside the mast-mount or rack-mount RFC.
10. Replace the RFC.

**“BPV” LIGHT ON T1-A OR B IS LIT**

This alarm will activate when the incoming T1 stream presents BPVs.

**RECOMMENDED ACTION**
**POSSIBLE CAUSE**
**(SEE LIST BELOW)**

- The incoming T1 contains BPVs or errors. .... 1
- The line codes between DS1/DSX-1 equipment and the Tracer are incompatible. .... 2

**RECOMMENDED ACTIONS:**

1. Check the incoming DS1/DSX-1 signal for BPVs using a T1 test set.
2. Correct the line code on the Tracer or DS1/DSX-1 equipment.

**RED LIGHT ON T1-A OR B IS LIT**

This alarm (Loss of Signal) will activate when there is no signal present at the T1 interface.

**RECOMMENDED ACTION**
**POSSIBLE CAUSE**
**(SEE LIST BELOW)**

- No DS1/DSX-1 signal or a degraded DS1/DSX-1 signal is present at the DS1/DSX-1 input. .... 1,2
- The connection at the T1 input or DS1/DSX-1 equipment is faulty. .... 2

**RECOMMENDED ACTIONS:**

1. Verify the presence of a DS1/DSX-1 signal at the T1 monitor jack using a T1 test set.
2. Verify that all cables and connectors are correctly wired.

**IMPORTANT**

If problems persist after you have followed the Recommended Actions, contact ADTRAN Technical Support at (800) 726-8663.

**“LBK-A” OR “LBK-B” IS LIT**

This alarm will activate when a software or manual T1 loopback has been established.

<b>POSSIBLE CAUSE</b>	<b>RECOMMENDED ACTION (SEE LIST BELOW)</b>
• A loopback has been commanded from the VT-100 user interface. ....	1,2
• The “LBK-A” or “LBK-B” button has been pressed. ....	1,2

**RECOMMENDED ACTIONS:**

1. Through the VT-100 user interface, deactivate the loopback in the Loopback Menu.
2. Press the “LBK-A” or “LBK-B” button to deactivate the loopback.

**“AIS/YEL” ON T1-A OR T1-B IS LIT**

The AIS/YEL light will flash for AIS when the DS1/DSX-1 input receives a “blue code” (a string of 2316 1s with no more than one zero). The indicator will remain on (solid) if a YEL signal is present on the T1.

<b>POSSIBLE CAUSE</b>	<b>RECOMMENDED ACTION (SEE LIST BELOW)</b>
• For AIS, the DS1/DSX-1 equipment is sending a “blue code” (all 1s) to the T1 input. ....	1,2
• For YEL, the received T1 is receiving a yellow signal from the far-end T1, indicating the far-end T1 is RED. ....	3-5

**RECOMMENDED ACTIONS:**

1. Reset the T1 equipment and verify normal operation.
2. Verify the presence of a DS1/DSX-1 signal at the T1 monitor jack using a T1 test set.
3. Check the far-end equipment for alarms or a red condition.
4. Check the T1 connections at the far-end equipment.
5. Reset the far-end equipment.

---

**I M P O R T A N T**

---

If problems persist after you have followed the Recommended Actions, contact ADTRAN Technical Support at (800) 726-8663.

---

**“AIS/YEL” INDICATOR IS FLASHING**

This alarm is activated when the T1 interface at the remote end is not receiving a T1 signal (it is in Red alarm). In this circumstance the interface with the flashing AIS/YEL indicator is transmitting an AIS (keep alive) signal.

**RECOMMENDED ACTION****(SEE LIST BELOW)****POSSIBLE CAUSE**

- No DS1/DSX-1 signal or a degraded DS1/DSX-1 signal is present at the DS1/DSX-1 input. .... 1,2
- The connection at the T1 input or DS1/DSX-1 equipment is faulty. .... 2

**RECOMMENDED ACTIONS:**

1. Verify the presence of a DS1/DSX-1 signal at the T1 monitor jack using a T1 test set.
2. Verify that all cables and connectors are properly wired.

**No “POWER” LIGHT****RECOMMENDED ACTION****(SEE LIST BELOW)****POSSIBLE CAUSE**

- DC voltage is not applied. .... 1,2,4
- The polarity of the power connection is reversed. .... 2
- The AC transformer is not functioning properly. .... 3,4
- The AC transformer is not connected to the DC jack on the BBP, or not connected to AC outlet. .... 3,4

**RECOMMENDED ACTIONS:**

1. Verify that the DC voltage is between 21-56 VDC ( $\pm$ ).
2. Verify that negative voltage is applied to the negative terminal, and positive voltage applied to the positive terminal.
3. Verify that the “Power” light is lit on the AC transformer.
4. Verify that the AC transformer is connected to an AC power cord on the transformer, and connected to the DC jack on the BBP. Verify that the AC power cord is connected to an AC outlet. Verify that the AC outlet has proper AC voltage present.

**IMPORTANT**

If problems persist after you have followed the Recommended Actions, contact ADTRAN Technical Support at (800) 726-8663.

**“TEST” LIGHT IS LIT OR BLINKING**

The test alarm will remain on (solid) during power-up, indicating a self-test is in progress. The light will flash or remain on (solid) if the self-test fails.

<b>POSSIBLE CAUSE</b>	<b>RECOMMENDED ACTION (SEE LIST BELOW)</b>
• One-flash interval indicates a RAM test failure. ....	1
• Two-flash interval indicates the T1-C mux failed internal test. ....	1
• Three-flash interval indicates the T1-A framer failed. ....	1
• Four-flash interval indicates the T1-B framer failed. ....	1
• Five-flash interval indicates a DSP failure. ....	1
• On (solid) indicates a faulty internal component. ....	1

**RECOMMENDED ACTIONS:**

1. Replace the BBP or the RFC.

**“TST” LIGHT IS LIT AFTER PRESSING “REMOTE TEST” BUTTON**

The Remote Test light will activate during a remote test in progress. The Remote Test performs a 10-second bit error rate test (BERT) over the RF link to the far-end.

<b>POSSIBLE CAUSE</b>	<b>RECOMMENDED ACTION (SEE LIST BELOW)</b>
• A Remote Test has been activated from the front panel “Remote Test” button or the VT-100 user interface. ....	1

**RECOMMENDED ACTIONS:**

1. Allow the remote test to complete. If the Remote Test Fail light does not activate, the remote test passed. If the Remote Test Fail light activates, see section on FAIL light is lit after pressing Remote Test button.

---

**I M P O R T A N T**

---

If problems persist after you have followed the Recommended Actions, contact ADTRAN Technical Support at (800) 726-8663.

---

**“FAIL” LIGHT IS LIT AFTER PRESSING “REMOTE TEST” BUTTON**

The Remote Fail light will activate after a Remote Test has failed.

<b>POSSIBLE CAUSE</b>	<b>RECOMMENDED ACTION (SEE LIST BELOW)</b>
• The 10-second BERT has failed over the RF link to the far-end. ....	1
• The RX power may be below or near the -91 dbm threshold. ....	1

**RECOMMENDED ACTIONS:**

1. Check the RX power level using the VT-100 user interface or the RSSI DC voltage test points. Verify the RX power is between -55 & -91 dbm.

**“RF Low” LIGHT IS ON**

This alarm will activate if the RX power is below -80 dbm.

<b>POSSIBLE CAUSE</b>	<b>RECOMMENDED ACTION (SEE LIST BELOW)</b>
• The RX power is below -80 dBm. ....	1-5,7,8
• The far-end transmitter is off, or is transmitting low power. ....	2-5,7,8
• The RF path is not aligned. ....	3,8
• Water is in the antenna feedhorn or connectors. ....	4,8

**RECOMMENDED ACTIONS:**

1. Verify the RX power is between -55 & -91 dBm using the VT-100 user interface or RSSI DC voltage test points.
2. Check the far-end transmitter for operation and proper transmit power.
3. Check the RF path using a spectrum analyzer or RSSI voltages for proper alignment. Have path professionally re-aligned and check system path engineering.
4. Check the antenna feedhorn and all outdoor connections for water.
5. Check all connections between the BBP, the RFC, and the antenna.
6. Check the IF and RF cables for shorts.
7. Check the connections inside the mast-mount or rack-mount RFC.
8. Replace the RFC.

**I M P O R T A N T**

If problems persist after you have followed the Recommended Actions, contact ADTRAN Technical Support at (800) 726-8663.

**TROUBLESHOOTING USING THE VT-100 USER INTERFACE**

This section provides information for troubleshooting the Alarm Menu on the VT-100 user interface. The conditions present in the Alarm Menu are software indications and should match the front panel LED indications.

**RED ALARM**

This alarm will activate when there is no signal present at the T1 interface. This alarm is the same as a RED alarm on the front panel.

<b>POSSIBLE CAUSE</b>	<b>RECOMMENDED ACTION (SEE LIST BELOW)</b>
• No DS1/DSX-1 signal or a degraded DS1/DSX-1 signal is present at the DS1/DSX-1 input. ....	1,2
• The connection at the T1 input or DS1/DSX-1 equipment is faulty. ....	2

**RECOMMENDED ACTIONS:**

1. Verify the presence of a DS1/DSX-1 signal at the T1 monitor jack using a T1 test set.
2. Verify that all cables and connectors are correctly wired.

**BPV ALARM**

The BPV alarm will activate whenever the incoming T1 stream presents BPVs.

<b>POSSIBLE CAUSE</b>	<b>RECOMMENDED ACTION (SEE LIST BELOW)</b>
• The incoming T1 contains BPVs or errors. ....	1
• The line codes between the DS1/DSX-1 equipment and the Tracer are incompatible. ....	2



---

**I M P O R T A N T**

---

If problems persist after you have followed the Recommended Actions, contact ADTRAN Technical Support at (800) 726-8663.

---

**RECOMMENDED ACTIONS:**

1. Check the incoming DS1/DSX-1 signal for BPVs using a T1 test set.
2. Correct the line code on the Tracer or DS1/DSX-1 equipment.

**YEL/AIS ALARM**

This alarm indicator will *flash* when a T1 Yellow alarm occurs. The indicator will remain on (solid) to indicator an AIS alarm when the DS1/DSX-1 is receiving a blue code (a string of 2316 1's with no more than 1 zero).

**RECOMMENDED ACTION****POSSIBLE CAUSE****(SEE LIST BELOW)**

- The DS1/DSX-1 equipment is sending a "blue code" (all 1's) to the T1 input. .... 1,2
- The far-end equipment is in a red condition and transmitting a yellow alarm. .... 3-5

**RECOMMENDED ACTIONS:**

1. Reset the upstream equipment and verify normal operation.
2. Verify the presence of a DS1/DSX-1 signal at the T1 monitor jack using a T1 test set.
3. Check the far-end equipment for alarms or a red condition.
4. Check the T1 connections at the far-end equipment.
5. Reset the far-end equipment.

**IMPORTANT**

If problems persist after you have followed the Recommended Actions, contact ADTRAN Technical Support at (800) 726-8663.

**RF LINK ALARM OR CODE SYNC ALARM**

The RF Link Alarm will activate when the link is down or not operational.

The Code Sync Alarm will activate when data synchronization has not been achieved between the RF link.

<b>POSSIBLE CAUSE</b>	<b>RECOMMENDED ACTION (SEE LIST BELOW)</b>
• The RF link is down. ....	1-10
• The RX power is below the -91 dbm threshold. ....	1-4,7-10
• The far-end transmitter is off, or is transmitting low power. ....	1-4,7-10
• The RF path is not aligned. ....	1,3,10
• Water is in the antenna feedhorn or connectors. ....	1,4
• Both units are set to the same frequency. ....	5,10
• Both units are not set to the same PN code. ....	6
• The connection between the BBP and the RFC is faulty. ....	1,7-10
• The connection between the RFC and the antenna is faulty. ....	1,7-10
• The BBP or RFC is faulty. ....	10

**RECOMMENDED ACTIONS:**

1. Check the RX power using the VT-100 user interface or RSSI voltage.
2. Check the far-end transmitter for operation and proper transmit power.
3. Check the RF path using a spectrum analyzer or RSSI voltages for proper alignment. Have path professionally re-aligned and check system path engineering.
4. Check the antenna feedhorn and all outdoor connections for water.
5. Change the frequency of one radio through the VT-100 user interface or front panel button.
6. Set both units to the same PN code.
7. Check all connections between the BBP, the RFC, and the antenna.
8. Check the IF and RF cables for shorts.
9. Check connections inside the mast-mount or rack-mount RFC.
10. Replace the RFC.

---

**I M P O R T A N T**

---

If problems persist after you have followed the Recommended Actions, contact ADTRAN Technical Support at (800) 726-8663.

---

**CARRIER SYNC ALARM OR T1 MUX FRAMER ALARM**

The Carrier Sync alarm will activate when frequency synchronization has not been achieved between the RF link.

The T1 Mux Framers alarm will activate when synchronization between the T1 mux on each radio has not been achieved.

<b>POSSIBLE CAUSE</b>	<b>RECOMMENDED ACTION (SEE LIST BELOW)</b>
• The RF link is down. ....	1-10
• The RX power is below the -91 dbm threshold. ....	1-4,7-10
• The far-end transmitter is off, or is transmitting low power. ....	1-4,7-10
• The RF path is not aligned. ....	1,3,10
• Water is in the antenna feedhorn or connectors. ....	1,4
• Both units are set to the same frequency. ....	5,10
• Both units are not set to the same PN code. ....	6
• The connection between the BBP and the RFC is faulty. ....	1,7-10
• The connection between the RFC and the antenna is faulty. ....	1,7-10
• The BBP or RFC is faulty. ....	10

**RECOMMENDED ACTIONS:**

1. Check the RX power using the VT-100 user interface or RSSI voltage (refer to RSSI voltage chart)
2. Check the far-end transmitter for operation and proper transmit power.
3. Check the RF path using a spectrum analyzer or RSSI voltages for proper alignment. Have path professionally re-aligned and check system path engineering.
4. Check the antenna feedhorn and all outdoor connections for water.
5. Change the frequency of one radio through the VT-100 user interface or front panel button.
6. Set both units to the same PN code.
7. Check all connections between the BBP, the RFC, and the antenna.
8. Check the IF and RF cables for shorts.
9. Check connections inside the mast-mount or rack-mount RFC.
10. Replace the RFC.

**I M P O R T A N T**

If problems persist after you have followed the Recommended Actions, contact ADTRAN Technical Support at (800) 726-8663.

**ES VALUES IN T1 STATUS MENU**

This value indicates the number of Errored Seconds in the T1 data stream.

<b>POSSIBLE CAUSE</b>	<b>RECOMMENDED ACTION (SEE LIST BELOW)</b>
• In an AMI-coded T1, a BPV or frame bit error has occurred. ....	1
• In an ESF-coded T1, a BPV or CRC error has occurred. ....	1

**RECOMMENDED ACTIONS:**

1. Check the T1 signal with a BERT test set to determine origin of error.

**SES VALUES IN HISTORY MENU**

This value indicates the number of Severely Errored Seconds in the T1 data stream.

<b>POSSIBLE CAUSE</b>	<b>RECOMMENDED ACTION (SEE LIST BELOW)</b>
• In an AMI-coded T1, 1544 BPVs or 8 frame bit errors have occurred. ....	1
• In an ESF-coded T1, 1544 BPVs or 320 CRC errors have occurred. ....	1

**RECOMMENDED ACTION:**

1. Check the T1 signal with a BERT test set to determine origin of error.

## SECTION 5 SPECIFICATIONS

---

This section lists the specifications for the Tracer system.

### TRANSMITTER

Output Power .....	+20 dBm, maximum
Frequency Range .....	2400 to 2483.5 MHz
Channel Bandwidth .....	40 MHz (two channels)
I/F .....	140 MHz

### RECEIVER

Receive Level, range .....	-30 to -91 dBm ( $10^{-6}$ BER)
Receive Level, maximum .....	-30 dBm
Receive Level, nominal .....	-60 dBm
AGC Range .....	61 dBm

### FREQUENCY PLAN

Plan A .....	Tx 2.422 GHz, Rx 2.462 GHz
Plan B .....	Tx 2.462 GHz, Rx 2.422 GHz

### SPREAD SPECTRUM DATA PUMP

Modulation .....	QPSK
Spreading Method .....	Direct sequence
Code Length .....	120 bits
Processing Gain .....	>12 dB
Number of Codes .....	10
Chipping Rate .....	12 times

**INTERFACE SPECIFICATIONS**

Capacity .....	2 x T1
Connection .....	RJ-48C, bantam
Line Code .....	AMI, B8ZS
Framing .....	SF, ESF
Alarms .....	AIS, Red, Yellow, BPVs
Loopbacks .....	Local and remote, per T1 channel

**USER INTERFACE**

Front Panel .....	Alarm LEDs, Configuration Switches, Monitor Jacks
Diagnostics .....	T1 Loopback, Remote Test with built-in BERT
Test Points .....	RSSI, System Voltages, QPSK Constellation
VT-100 Terminal .....	Menu-Driven User Interface, Control of the Remote End, Password Protected (Optional), Event History

**VT-100 TERMINAL INTERFACE**

Data Rate .....	9600 bps
Data Bits .....	8
Parity .....	None
Stop Bits .....	1
Terminal Emulation .....	VT-100

**MECHANICAL & ENVIRONMENTAL****Baseband Processor**

Operating Temperature .....	0°C to 50°C
Size .....	19" x 1.75" x 11.5"
Humidity .....	95%, Non-condensing
Weight .....	6 lbs.

**Rack RFC**

Operating Temperature .....	0°C to 50°C
Size .....	19" x 1.75" x 11.5"
Humidity .....	95%, Non-condensing
Weight .....	6 lbs.

**Mast Unit**

Operating Temperature .....	-40°C to 65°C
Size .....	21" high x 9" diameter
Humidity .....	100%
Weight .....	18 lbs.

**POWER**

Input Voltage .....	21 to 56 volts DC, either polarity referenced to ground
Power Consumption .....	30 watts
Connector .....	3 pin DIN (AC adapter) 3 pin screw clamp terminal block (DC)





## SECTION 6 **WARRANTY, ORDERING AND RETURN INFORMATION**

---

### **WARRANTY**

Adtran will replace or repair this product within five years from the date of shipment if it does not meet its published specifications or fails due to defects in materials and workmanship.

For detailed warranty, repair, and return information, refer to the Adtran Equipment Warranty, Repair, and Return Policy and Procedure.

### **SALES**

For Tracer sales information, contact Adtran Sales at:

(800) 827-0807

### **REPAIRS AND RETURNS**

Return Material Authorization (RMA) is required prior to returning equipment to Adtran.

For RMA information, contact Adtran at:

(205) 963-8722

or

Adtran, Inc.  
Customer Service Department  
P.O. Box 140000  
901 Explorer Boulevard  
Huntsville, Alabama 35806-2807

**TECHNICAL SUPPORT**

Standard support hours are 7 a.m. to 7 p.m. CST, Monday through Friday. Emergency technical support is available 24 hours a day, seven days a week.

For technical support at any time, contact Adtran at:

(800) 726-8663

## ACRONYMS USED IN THIS MANUAL

AMI .....	Alternate Mark Inversion
B8ZS .....	Bipolar 8 zero substitution
BER .....	Bit error rate
BBP .....	Baseband Processor
CRC .....	Cyclic Redundancy Check
DCE .....	Data Communications Equipment
DTE .....	Data Terminal Equipment
ESF .....	Extended superframe
FCC .....	Federal Communications Commission
FEC .....	Forward error correction
IF .....	Intermediate Frequency
ISM .....	Industrial, Scientific, and Medical
LBK .....	Loopback
QPSK .....	Quadrature Phase Shift Keying
RF .....	Radio frequency
RFC .....	Radio frequency converter
RSSI .....	Received signal strength indicator
Rx .....	Receive
SF .....	Superframe
Tx .....	Transmit



## APPENDIX A CABLE CONNECTIONS

---

The cable connections required for various configurations are detailed below.

### TERMINAL CONNECTION (DB25)

<u>Tracer (DCE)</u>			<u>Terminal (DTE)</u>	
Number	Name		Number	Name
2 .....	TXD	↔	2 .....	TXD
3 .....	RXD	↔	3 .....	RXD
4 .....	RTS	↔	4 .....	RTS
5 .....	CTS	↔	5 .....	CTS
6 .....	DSR	↔	6 .....	DSR
7 .....	Ground	↔	7 .....	Ground

### PERSONAL COMPUTER CONNECTION (DB9)

<u>Tracer (DCE)</u>			<u>Computer (DTE)</u>	
Number	Name		Number	Name
2 .....	TXD	↔	3 .....	TXD
3 .....	RXD	↔	2 .....	RXD
4 .....	RTS	↔	7 .....	RTS
5 .....	CTS	↔	8 .....	CTS
6 .....	DSR	↔	6 .....	DSR
7 .....	Ground	↔	5 .....	Ground

### MODEM CONNECTION (DB25)

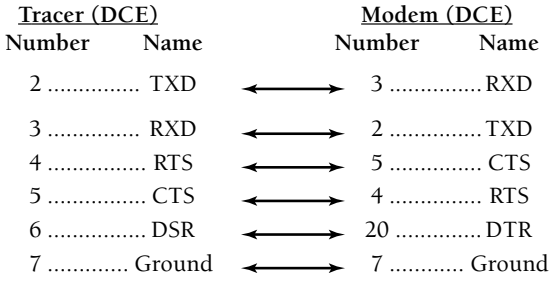

## APPENDIX B **FCC REGULATIONS**

---

1. This equipment complies with Part 68 of the FCC Rules. On the bottom of this equipment is a label that contains, among other information, the FCC Registration number for this equipment. If requested, provide this information to your telephone company.

2. Below is a list of all applicable registration jack USOCs (Facility Interface Codes and Service Order Codes) for the equipment. This information is required when ordering service from the Telco.

SERVICE	SOC	FIC	USOC
T1	6.0N	04DU9-BN, 04DU9-DN	RJ-48C

3. An FCC-compliant telephone cord and a modular plug are provided for this equipment. This equipment is designed to be connected to the telephone network or premises wiring using a compatible modular jack which is Part 68 compliant. See Installation Instructions for details.

4. If your telephone equipment (Tracer) causes harm to the telephone network, the telephone company may discontinue your service temporarily. If possible, they will notify you in advance. But if advance notice is not practical, you will be notified as soon as possible. You will be advised of your right to file a complaint with the FCC if you believe it is necessary.

5. Your telephone company may make changes in its facilities, equipment, operations, or procedures that could affect the proper operation of your equipment. If they do, you will be given advance notification so as to give you an opportunity to maintain uninterrupted service.

6. If you experience trouble with this equipment (Tracer), please contact Adtran at (205) 971-8000 for repair/warranty information. The telephone company may ask you to disconnect this equipment from the network until the problem has been corrected, or until you are sure the equipment is not malfunctioning.

7. This unit contains no user-serviceable parts.

## APPENDIX B

8. This equipment may not be used on public coin service provided by the telephone company. Connection to party lines is subject to state tariffs. (Contact your state public utility commission or corporation commission for information.)

9. Connection of Private Communication Systems: Private communication systems (microwave, etc.) may be directly connected to the network through the use of VP couplers; or to station ports behind registered host systems. However, in the latter case, Telco tariffs require that a signal power affidavit be filed with the telephone company to assure that the system will not generate excess signal power. The tariffs also require the privately-owned communication system go immediately on hook in the event of failure.

10. Affidavit requirements for connection to digital services:

- An affidavit is required to be given to the telephone company when digital terminal equipment without encoded analog content and billing protection is used to transmit digital signals containing encoded analog content which are intended for eventual conversion into voice band analog signals and transmitted on the network.
- The affidavit shall affirm that either no encoded analog content or billing information is being transmitted or that the output of the device meets Part 68 encoded catalog content or billing protection specifications.
- End user/customer will be responsible to file an affidavit with the local exchange carrier when connecting unprotected CPE to a 1.544 Mbps or subrate digital services.
- Until such time as subrate digital terminal equipment is registered for voice applications, the affidavit requirements for subrate services is waived.



**AFFIDAVIT FOR CONNECTION OF CUSTOMER PREMISES EQUIPMENT TO  
1.544 MBPS AND/OR SUBRATE DIGITAL SERVICES**

For the work to be performed in the certified territory of

\_\_\_\_\_  
(TELCO NAME)

State of \_\_\_\_\_

County of \_\_\_\_\_

I, \_\_\_\_\_

(NAME)

\_\_\_\_\_  
(BUSINESS ADDRESS)

\_\_\_\_\_ being duly sworn, state:

(TELEPHONE NUMBER)

I have responsibility for the operations and maintenance of the terminal equipment to be connected to 1.544 Mbps and/or subrate digital services. The terminal equipment to be connected complies with Part 68 of the FCC rules except for the encoded analog content and billing protection specifications. With respect to encoded analog content and billing protection:

I attest that all operations associated with the establishment, maintenance, and adjustment of the digital CPE with respect to analog content and encoded billing protections information continuously complies with Part 68 of the FCC Rules and Regulations.

The digital CPE does not transmit digital signals containing encoded analog content or billing information which is intended to be decoded within the telecommunications network.

The encoded analog content and billing protection is factory set and is not under the control of the customer.

APPENDIX B

I attest that the operator(s)/maintainer(s) of the digital CPE responsible for the establishment, maintenance, and adjustment of the encoded analog content and billing information has (have) been trained to perform these functions by successfully having completed one of the following (check appropriate blocks):

[ ] A. A training course provided by the manufacturer/grantee of the equipment used to encode analog signals; or

[ ] B. A training course provided by the customer or authorized representative, using training materials and instructions provided by the manufacturer/grantee of the equipment used to encode analog signals; or

[ ] C. An independent training course (e.g., trade school or technical institution) recognized by the manufacturer/grantee of the equipment used to encode analog signals; or

[ ] D. In lieu of the preceding training requirements, the operator(s)/maintainer(s) is (are) under the control of a supervisor trained in accordance with (CIRCLE ONE) above.

I agree to provide \_\_\_\_\_ (TELCO NAME)

with proper documentation to demonstrate compliance with the information as provided in the preceding paragraph, if so requested.

\_\_\_\_\_  
(SIGNATURE)

\_\_\_\_\_  
(TITLE)

\_\_\_\_\_  
(DATE)

Transcribed and sworn to before me  
this \_\_\_\_\_ day of \_\_\_\_\_, \_\_\_\_\_

\_\_\_\_\_  
(NOTARY PUBLIC)

My commission expires \_\_\_\_\_