

**52-7350UE5**

**UHF**

**DATA TRANSCEIVERS**

**PLL SYNTHESIZED (EEPROM)**

**Service Manual**

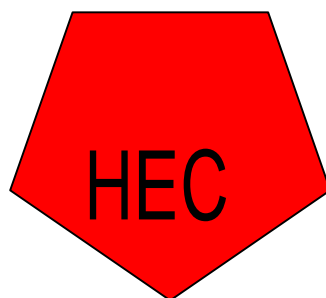

**HERMES ELECTRONICS CO., LTD.**

# TABLE OF CONTENTS

|   |       |
|---|-------|
| 1. SPECIFICATION .....                  | 2     |
| 2. CONNECTIONS AND OPERATION .....      | 3     |
| 3. CIRCUIT DESCRIPTION .....            | 4-12  |
| 4. PERFORMANCE TEST AND ALIGNMENT ..... | 12    |
| 5. TEST EQUIPMENT CONFIGURATION .....   | 13    |
| 6. TRANSMITTER PERFORMANCE TEST .....   | 14-16 |
| 7. TROUBLESHOOTING .....                | 17-19 |
| 9. PARTS LIST .....                     | 20-28 |
| 8. PROGRAMMER INSTRUCTION .....         | 29-34 |
| 10. PRINT CIRCUIT BOARD LAYOUT.....     | 35-38 |
| 11. PARTS ASSEMBLY .....                | 39-41 |
| 12. BLOCK DIAGRAM .....                 | 42    |
| 13. SCHEMATICS DIAGRAM .....            | 43-44 |

# **1. SPECIFICATION**

## **GENERAL SPECIFICATIONS**

|   |                                      |         |          |
|---|--------------------------------------|---------|----------|
| POWER SOURCE .....                      | +13.6VD.C. nominal(+10.8 to +15.6V ) |         |          |
| TEMPERATURE RANGE                       |                                      |         |          |
| STORAGE .....                           | 80                                   | maximum | -40 min. |
|   | 25                                   | nominal |          |
| OPERATING .....                         | 60                                   | maximum | -20 min. |
| ANTENNA IMPEDANCE .....                 | 50                                   |         |          |
| FREQUENCY CONTROL .....                 | PLL SYNTHESISER                      |         |          |
| FREQUENCIES OF OPERATION .....          | each band 10MHZ,from 400-510MHZ      |         |          |
| FREQUENCY TOLERANCE AND STABILITY ..... | ± 1.5PPM                             |         |          |
| HIGH HUMIDITY .....                     | 90 %                                 |         |          |
| CHANNEL CAPABILITY .....                | 16 by software control               |         |          |
| NOMINAL DIMENSIONS .....                | 134 mm(L)X60 mm(W)X33 mm(H)          |         |          |
| WEIGHT .....                            | 204g                                 |         |          |

## **RADIO DATA TRANSCEIVER NOMINAL PERFORMANCE**

|                                  |             |  |  |
|----------------------------------|-------------|--|--|
| PERFORMANCE SPECIFICATIONS ..... | FCC PART 90 |  |  |
| RF OUTPUT POWER .....            | 5W          |  |  |
| MODULATION TYPE .....            | FM          |  |  |
| INTERMEDIATE FREQUENICES .....   | 21.4 MHZ    |  |  |
|                                  | 455 KHZ     |  |  |
| CHANNEL SPACING .....            | 12.5 KHZ    |  |  |
| TRANSMIT ATTACK TIME .....       | < 25 mS     |  |  |
| CURRENT CONSUMPTION              |             |  |  |
| TRANSMIT .....                   | 1200mA@5W   |  |  |
| RECEIVE .....                    | 85mA        |  |  |

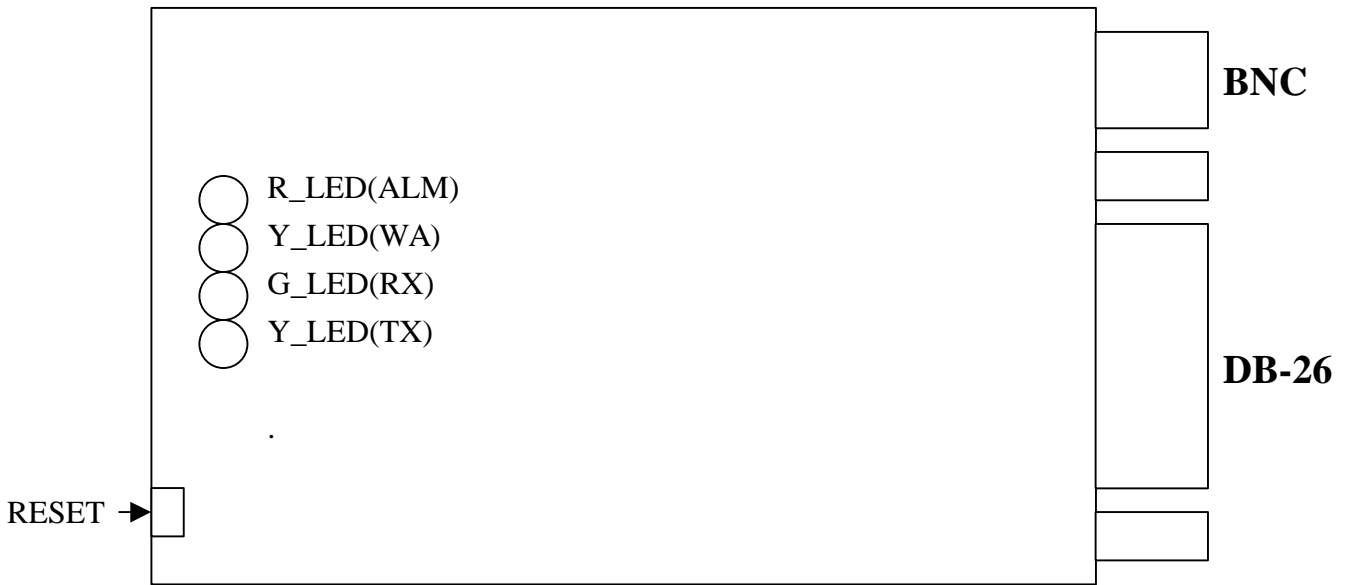

| DB-26 DEFINE |                                   |
|--------------|-----------------------------------|
| PIN NO.      | FUNCTION                          |
| 1            | GROUND FROM EXTERNAL POWER SUPPLY |
| 2            | B+ FROM EXTERNAL POWER SUPPLY     |
| 3            | PGM_DATA                          |
| 4            | PGM_ENB                           |
| 5            | TROUBLE –OPEN COLLECTOR Q2        |
| 6            | VCC OUT                           |
| 7            | ZONE 1 IN                         |
| 8            | DIGITAL GROUND                    |
| 9            | ZONE 2 IN                         |
| 10           | ZONE 3 IN                         |
| 11           | DIGITAL GROUND                    |
| 12           | ZONE 4 IN                         |
| 13           | N/C                               |
| 14           | PHONE LINE PING                   |
| 15           | PHONE LINE TIP                    |
| 16           | DIGITAL GROUND                    |
| 17           | RX                                |
| 18           | TX                                |
| 19           | DTR                               |
| 20           | DSR                               |
| 21           | +12VDC                            |
| 22           | CH SEL 1                          |
| 23           | CH SEL 2                          |
| 24           | CH SEL 4                          |
| 25           | CH SEL 8                          |
| 26           | N/C                               |

| CHSEL \ CH | 0 | 1 | 2 | 3 | 4 | 5 | 6 | 7 | 8 | 9 | 10 | 11 | 12 | 13 | 14 | 15 |
|------------|---|---|---|---|---|---|---|---|---|---|----|----|----|----|----|----|
| CH SEL 1   | 1 | 0 | 1 | 0 | 1 | 0 | 1 | 0 | 1 | 0 | 1  | 0  | 1  | 0  | 1  | 0  |
| CH SEL 2   | 1 | 1 | 0 | 0 | 1 | 1 | 0 | 0 | 1 | 1 | 0  | 0  | 1  | 1  | 0  | 0  |
| CH SEL 4   | 1 | 1 | 1 | 1 | 0 | 0 | 0 | 0 | 1 | 1 | 1  | 1  | 0  | 0  | 0  | 0  |
| CH SEL 8   | 1 | 1 | 1 | 1 | 1 | 1 | 1 | 1 | 0 | 0 | 0  | 0  | 0  | 0  | 0  | 0  |

### **3. CIRCUIT DESCRIPTION**

#### **TRANSMITTER**

The transmitter is comprised of:

- Audio amplifier connections from J902 pin 1
- Frequency Synthesizer
- Transmitter
- Automatic Power Control

#### **Audio frequency connections**

Processed data from the IC504 is applied to the VCO via R316 and applied to the TCXO VC

#### **Frequency synthesizer circuit**

With data received from the EEPROM (IC5) the frequency synthesizer circuit controls and Produces the RF carrier frequency for the transmitter during transmit and the local oscillator frequency for the receiver. The frequency synthesizer circuit is comprised of:

- 12.8 MHZ Tcxo
- Voltage Controlled Oscillator (VCO) module
- Charge Pump and Loop Filter
- PLL Frequency Synthesizer
- Dual Modulus Prescaler

## PLL Synthesizer

The PLL synthesizer circuit is common to both the transmitter and receiver,

The synthesizer comprises:

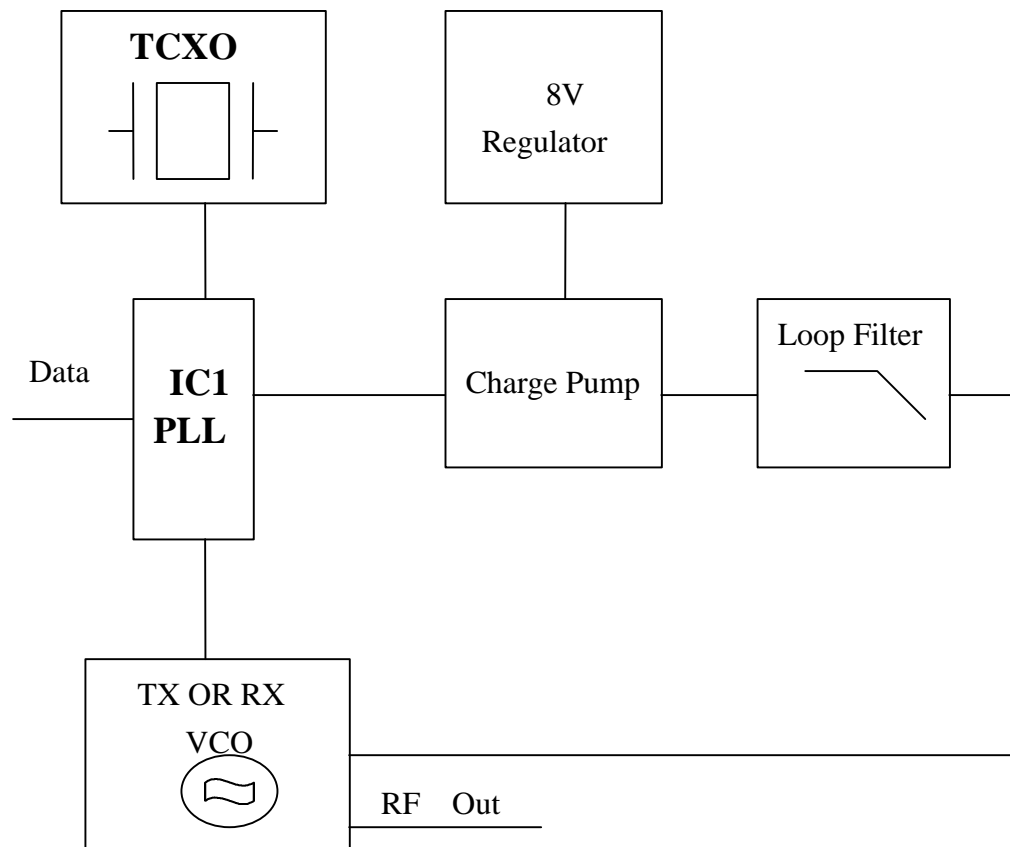

12.8 MHz TCXO

X1 is VCTCXO, which provides a stable oscillator of 12.8 MHz to PLL IC.

Frequency adjustment is provided by VR1

### .Voltage controlled oscillator module(VCO)

The module produces carrier frequencies during transmit and local oscillator frequencies during receive.

The module contains one VCO and three outputs. One for producing carrier frequencies during transmit and one for producing the local oscillator frequency during receive and the other output is for PLL IC(IC1) Fin.

The module also has Rx and TX powerline filters.

### RX and TX power line filters

Transistor Q301 is configured as a 5v power supply ripple filter. The filter reduces the noise on the carrier and local oscillator signals.

### VCO

The VCO comprises Q302, Coil L304, and varactor D301 D304 and is configured as a Colpits oscillator. D301 D304 produces a change in frequency with a change in DC voltage and is controlled by the tuning voltage signal present at the cathode. The local oscillator programmable dividers. DATA is received by IC1 at pin 10 from pin 11 of IC3.

The RF signal at the collector of Q302 is applied to an amplifier/buffer Q305. The amplified signal from Q305 passes to the prescaler, IC1 pin 8. The RF signal at the collector of Q302 also drives the cascode amplifier/buffer formed by Q304 and Q305.

When D201 is forward biased (TX ON), carrier frequencies at the collector of Q304 pass to the power amplifier and harmonic filter. When D303 is forward biased (RX), local oscillator frequencies at the collector of Q304 pass to the first mixer (Q102). VCQ1 adjusts the tuning voltage of the VCO to the correct operating point.

### PLL IC

The reference frequency from the TCXO, at 12.8 MHz, is connected to pin 1 of IC1 (MB1504). The appropriate VCO is connected to pin 11.

REFDIV divides the 12.8 MHz to produce a reference frequency ( $F_r$ ) of 5 or 6.25 kHz dependent upon channel spacing selected. VARDIV divides the prescaled VCO frequency to produce a variable frequency ( $F_v$ ).  $F_v$  and  $F_r$  are fed to the phase detector.

### Phase detector

When  $F_v = F_r$ , the phase detector output (pins 15 and 16, IC1) produces narrow negative pulses. And  $F_v$  and  $F_r$  pulse widths are identical. When  $F_v > F_r$  pin 15 (V) pulses negative with pin 16 (R) remaining high. When  $F_v < F_r$  pin 16 (R) pulses negative with pin 15 (V) remaining high. The signal at pin 15 and 16 is smoothed by the loop filter and applied to the VCO.

### Out-of-lock detector

The out-of-lock detector produces a series of logic level pulses when the loop is out of lock at pin 7 of IC1. The pulses at pin 7 of IC1 are buffered by Q6 and then integrated by R17 and C19. The product of the integrating circuit is fed to the base of Q201.

### Charge Pump and Loop Filter

Transistors Q2,Q4,Q10 , and associated resistors and capacitors form the charge pump and loop filter . The phase detector output from IC1 pins 15 and 16 are combined by the charge pump to Produce a 0 to 8V tuning voltage signal.

The signal is filtered by the loop filter (R13,C15 and C20) to remove any residual reference Frequency harmonics from the signal.. After filtering the signal is applied to the voltage controlled Oscillator module.

### DC REGULATOR

The DC Regulator IC2, converts the +13.6 V to a 8V supply . This is used to provide the Tuning voltage for the VCO . A wide voltage range is required to allow for the wideband operation Of the radio .

## Dual modulus prescaler

The prescaler divides the VCO frequency by 64 or 65.

## Transmitter

The transmitter comprises:

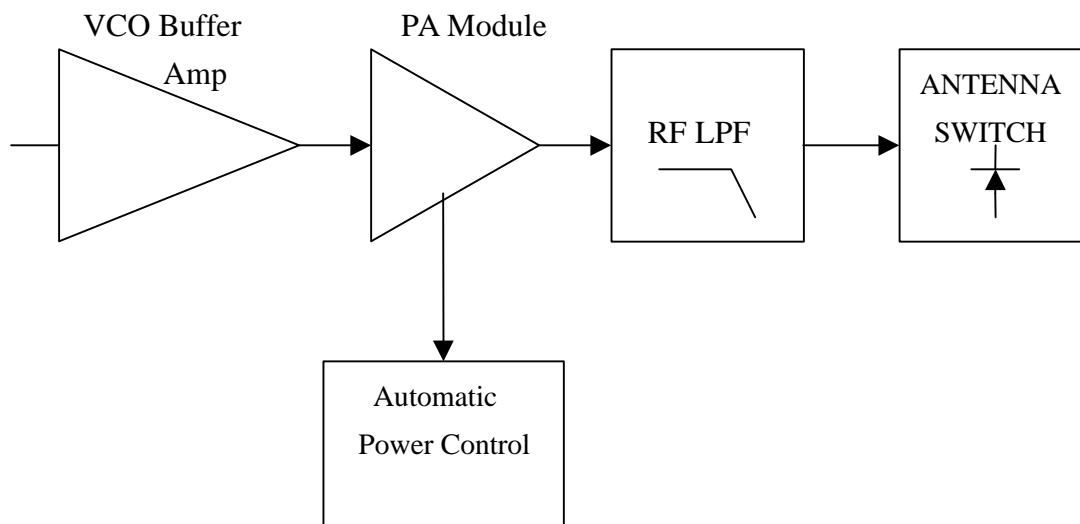



## **Buffer**

When the radio is in transmit mode the diode D201 is forward biased enabling the modulated RF signal from the VCO to pass to the buffer/pre-amplifier Q204 and associated components.

The output signal is passed from Q204 to Q205 via a matching network consisting of Inductor L201 and C208.

## **PA module**

The signal is then amplified for transmission by 207, which is a power amplifier module.

## **Low pass filter**

The amplified RF signal is passed through the stripline coupler and is fed to the harmonic low pass filter, comprising L213 to L214 and C232-C234 and then to the antenna connector (ANT).

## **Antenna Switch**

When transmitting, the diodes D205 are forward biased, allowing the RF to pass to the antenna. D205 is shorted to ground which makes L212 look open circuit (1/4 wave tuned stub). This prevents the TX signal from passing to the receiver stage.

## **Power output control .**

The RF power tuning by VC2, which make sure the current less than [1300mA@5W](#) output power.

# Receiver

The receiver comprises:

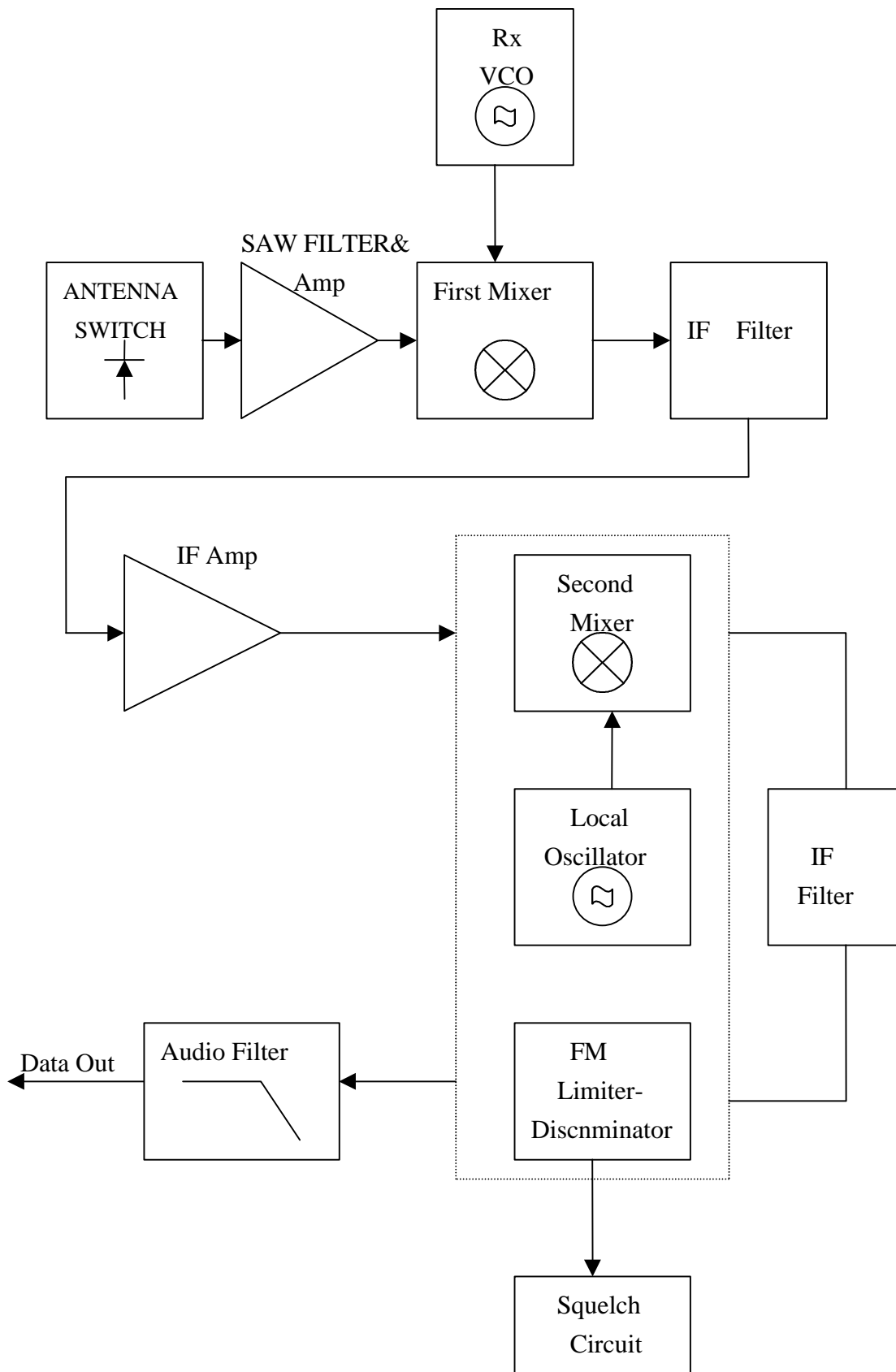

## **Antenna Switch**

In receive, the diode D205 are reverse biased. L212 is now in circuit, passing the signal from the antenna to the SAW filter of F101.

## **SAW FILTER**

The receiver signal is routed to pin 4 of the F101. It passes through the band pass filter .

The input signal is coupled to the base of Q101 which serves as an RF amplifier. The output of Q101 is then coupled to the first mixer.

## **First Mixer**

Q102, 2-pole crystal filters XF1 and coils L103 and C120 form the First Mixer and First IF Filter.

The RF signal, from the SAW filter and amplifier Q101 is applied to the VCO local oscillator signal to make mixer.

The difference frequency of 21.4 MHz is taken from Q102 and is filtered by the crystal filters XF1. The tuned circuits L103 and C120 and associated components provide matching of the crystal filters to ensure a good pass-band response and selectivity.

The IF signal is amplified by Q104 and passed to the FM Detector IC.

## **Second mixer, Second IF, FM detector**

The output of the IF amplifier is fed into the narrowband FM IF Integrated Circuit, IC101 (MC3361). This is a single conversion FM receiver which contains the second mixer, second IF amplifier, and FM detector.

Crystal X101, connected to pin 1 of IC101, determines the second local oscillator frequency. In this case the crystal has a frequency of 20.945MHz. The first IF signal is applied to the mixer and resultant frequency of 455KHz, is the difference between the IF signal and second local oscillator.

The 455KHz IF signal is output from pin 3 and is applied to a 455KHz band-pass filter CF1.

The output of CF1 is passed via pin 5 to a high gain IF amplifier coupled to the adjustable quadrature detector T2. Any detected signal is produced at pin 9 of IC101 and applied to the Receiver Audio Circuit and the Mute (Squelch) Circuit.

### Squelch ( MUTE ) Circuit

Any noise signal is amplified by IC101 internal noise amplifier .

Signal is applied to pin 10 of IC101. The squelch trigger output (pin 12, IC101) is applied to the pin 6 of J1.

When noise is present, the voltage at pin 12 of IC101 exceeds than 0.7V. The squelch trigger output is open, It's make pin 6 of J1 open state.

When no noise is present, the voltage at pin 12 of IC101 less 0.7v and pin 13 of IC101 is HI voltage. This make pin 6 of J1 short state.

VR101 is set to tuning squelch when 25khz channel space is present.

### Carrier Detect

A Carrier Detect ( MUTE DETECT ) output is available on pin 6 of J1 .

### AF Output Low Pass Filter

A low pass filter formed by R108 and C110 removes any extraneous 455kHz energy from the AF output of the FM receiver chip (pin 9 of IC101).

The filtered signal is passed to pin 2 of J1.

### Microcontroller

The PIC16C57C04 microcontroller IC controls the programmable features and frequency synthesizer Data.

## Programming Mode

The programming mode allows the user to retrieve or program TX/RX frequencies, when pin 9 of J1 is set to ground. Programming mode will Inhibit , Serial communications can then be made in order to read/program the on- board EEPROM ( IC5 )which contains radio- specific data.

## EEPROM

Relevant channel information, such as Rx/ Tx frequencies, is stored in the EEPROM( IC5) which is a 93C46. This information may be programmed and erased via the D- type socket. The EEPROM has 1024 (8x128) capacity and is written serially.

## Power supply circuit

The data radio is supplied with a nominal + 13.8V dc power supply input from external equipment which is filtered using C33. This supply is converted into 8V voltage levels on the board using the regulator IC2 and associated components .

The +5V VCC is regulated by Zener diode D1 and filtered using C9 and Q9. This +5V line is fed to the CPU circuit .

## **4. PERFORMANCE TEST AND ALIGNMENT**

The alignment and performance test procedures assume the use of the following equipment.

### **Discrete test equipment**

|  |  |
|--|--|
| Volt Meter                                 | Spectrum Analyser and notch filter(option) |
| RF Power Meter.                            | Coupler (20dB isolation)                   |
| DC Power Supply, 0-15V 2A min              | Distortion Meter                           |
| Oscilloscope, 20 MHz dual beam             |  |
| RF Frequency Counter,<br>100 kHz - 600 MHz |  |
| AF Signal Generator 0 – 20 kHz             |  |
| RF Signal Generator                        |  |
| SINAD Meter                                |  |
| Modulation Meter                           |  |
| Audio Power Meter                          |  |

# 5. TEST EQUIPMENT CONFIGURATION.

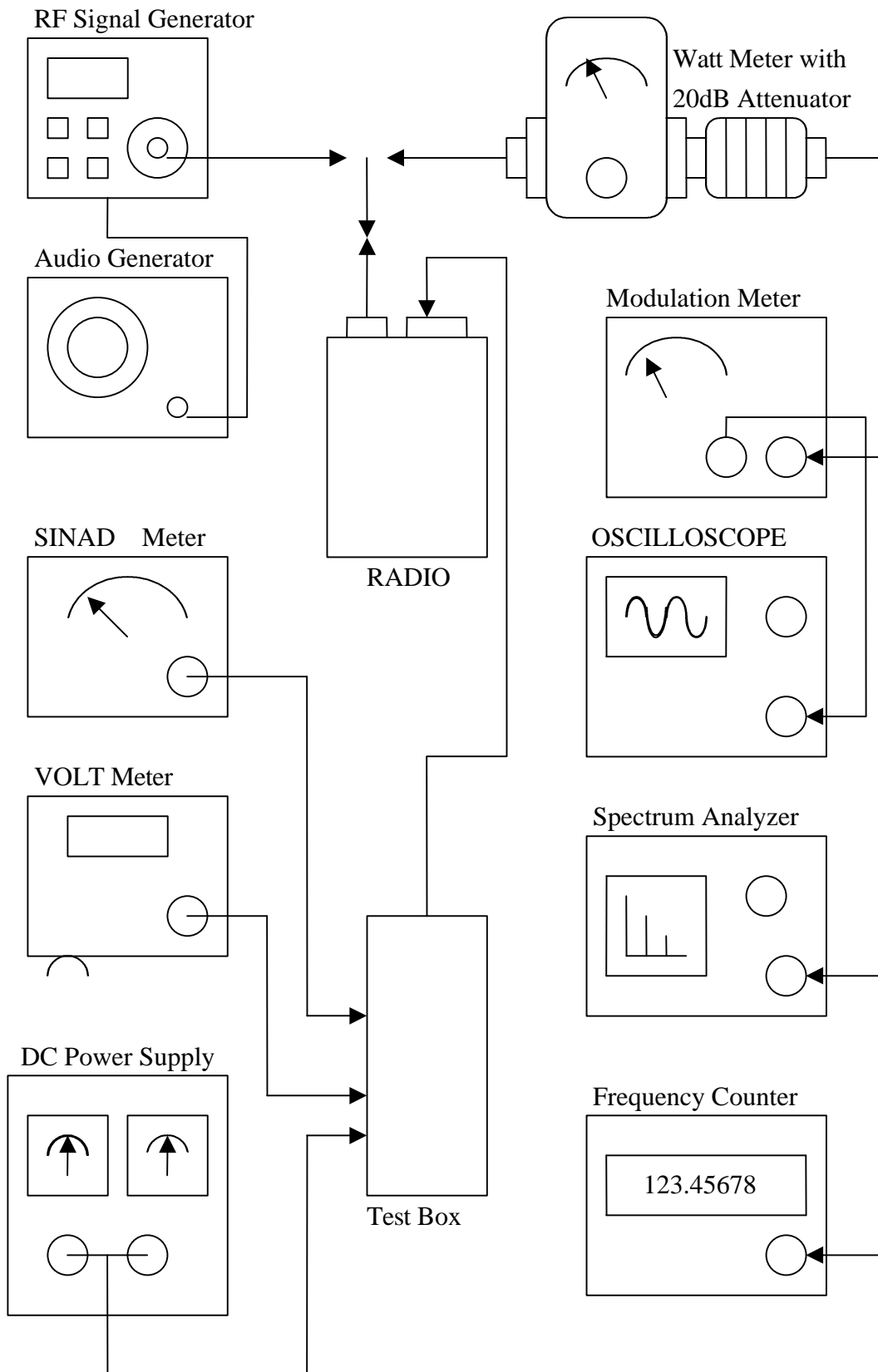

Test Equipment Configuration

## **6. TRANSMITTER PERFORMANCE TESTS**

### **Power Output**

1. Set the power supply voltage to 13.8V dc. and monitor the voltage during transmit.
2. Switch data radio TX and check and record the output power. The nominal output power is adjustable about 5W .
3. Set the PTT switch to OFF .

### **Peak Deviation**

1. Connect the oscilloscope to the output of the modulation meter.
2. Set the AF signal generator to 1000 Hz at 106mV and connect to DATA \_IN Line ( pin 1 of J903 )
3. Switch data radio to TX and observe the oscilloscope display to check that the 1000Hz tone is a sine wave and adjust RV501 to make deviation is about 3.5KHZ.
4. Using the AF signal generator, sweep from 100 Hz to 3 kHz and record the peak deviation.
5. Check the peak deviation for appropriate channel spacing as follows :  
For 12.5 kHz channel spacing, Peak deviation is not greater than 2.5 kHz.  
For 20 kHz channel spacing, Peak deviation is not greater than 4 kHz.  
For 25 kHz channel spacing, Peak deviation is not greater than 5 kHz.

### **Spectrum Test**

It may be necessary to notch the fundamental signal during this test.

1. Connect a spectrum analyser and RF power meter to the antenna socket.
2. Switch data radio to TX. Observe the output spectrum on the spectrum analyser.
3. Adjust notch filter to minimise the carrier. All spurious and harmonics signals should be below- 36 dBm up to 1 GHz and below -30 dBm between 1 and 4 GHz.
4. Switch off the data radio transmit control.

### **Receiver Performance Tests**

#### **Sensitivity**

The SINAD performance test may be used to test the sensitivity of the receiver.

1. Connect the RF signal generator to the data radio BNC antenna connector.
2. Set the RF signal generator to the receive frequency .
3. Connect the leads of the SINAD meter between 0 V and pin 2 on J903.
4. Set the deviation to 60 % of the peak system deviation.
5. Set the AF generator to 1 kHz.
6. Adjust the RF signal generator level until the SINAD Meter reads 12 dB.
7. Check that the signal generator RF level is less than 0.35uV pd (-116dBm ).

## **Transmitter Alignment**

### **Automatic Power Adjustment**

Transmit periods longer than 3 minutes are to be avoided.

1. Switch to data radio to TX.
2. Adjust VC2 to make the transmit power 5W and make sure the current less than 1300 mA.
3. Switch the data radio to transmitter OFF.

### **Frequency accuracy**

1. Whilst transmitting, measure the transmit frequency using the RF frequency counter.
2. Adjust VR1 so that frequency is as close as possible to the exact required transmit frequency. Ideally it should be within 100 Hz at room temperature.

### **Receiver Alignment**

**Important note** : Before setting up the receiver it is important to check the frequency accuracy alignment is correct as described in the transmitter alignment section.

### **RF tuning**

1. Connect an RF signal generator and SINAD voltmeter.
2. Set the RF signal generator to the receive channel frequency and set to 60 % deviation.
3. Set the AF signal to 1 kHz.
4. Set the RF level to 1 mV pd (- 47.0 dBm )
5. Adjust T2 for maximum AF output about 250mV to 350mV and lowest distortion, the distortion normally less than 5 % .
6. Check for an RF voltage signal level of 0.35uV pd (- 116dBm) and a SINAD meter Reading greater than 12 dB.

### **Squelch Carrier Detect Adjustment**

1. Set the RF signal generator to the receiver frequency with 60 % deviation. Set the AF Signal to 1 kHz
2. Set RF input level to give -112 dBm.
3. Adjust VR101 until CDS J903 pin 6 changes state from “HIGH” to “LOW”.
4. Reduce RF input level to -120dBm and check that CDS line goes HIGH . Switch off the RF generator and disconnect the test equipment.



## **Modulation Deviation Adjustment**

1. Connect a power meter, modulation meter and oscilloscope to radio.
2. The radio should be programmed to contain a channel with a frequency in the middle the band of interest with an RF power setting of 5 W.
3. Switch the data radio ON.
4. Inject a 106mVrms SINE wave signal at a frequency of 1000Hz into pin 1 of J903, Set the data radio to TX Observe the oscilloscope display to check that the 1000Hz tone is a sine wave by tuning VR201 and set deviation is 3.5KHZ.
5. Using the AF signal generator, sweep from 100 Hz to 3 kHz and record the peak deviation.

Check the peak deviation for appropriate channel spacing as follows :

12.5 kHz channel spacing  $\leq$  2.5 kHz dev

20 kHz channel spacing  $\leq$  4 kHz dev

25 kHz channel spacing  $\leq$  5 kHz dev

6. Switch to RX.

## 7. TROUBLESHOOTING

The section includes voltage which should assist the engineer to isolate and repair the fault.

Voltage measurements should be made using a high-impedance voltmeter and the values given are with respect to ground.

Careful alignment, using suitable test equipment, and quality interface cables should ensure that the radio meet their specified performance.

### Voltage Charts

Measurement Condition: 465MHZ,13.8V supply, RX Carrier Present.

#### Transistors .

| Ref. No. | RX   |       |      | TX   |      |      |
|----------|------|-------|------|------|------|------|
|          | B    | C     | E    | B    | C    | E    |
| Q1       | 4.31 | 4.98  | 4.99 | 4.31 | 4.98 | 4.99 |
| Q2       | 8.1  | 2.33  | 8.1  | 7.8  | 5.5  | 7.8  |
| Q4       | 0    | 2.33  | 0    | 0    | 5.5  | 0    |
| Q6       | 4.91 | 0     | 4.93 | 4.9  | 0    | 4.92 |
| Q7       | 0    | 8.1   | 0    | 4.93 | 0.02 | 0    |
| Q9       | 5.64 | 8.1   | 4.99 | 5.63 | 7.8  | 4.96 |
| Q10      | 4.16 | 8.1   | 3.76 | 4.15 | 7.8  | 3.75 |
| Q11      | 5.62 | 8.1   | 4.92 | 5.62 | 7.8  | 4.92 |
| Q14      | 8.1  | 0.2   | 8.1  | 7.08 | 7.63 | 7.8  |
| Q15      | 7.56 | 8.1   | 6.84 | 0.62 | 7.8  | 0    |
| Q101     | 0.74 | 3.93  | 0    | 0    | 0    | 0    |
| Q102     | 0.57 | 6.67  | 0    | 0    | 0    | 0    |
| Q103     | 5.21 | 0     | 0    | 0    | 11.9 | 0    |
| Q104     | 0.68 | 5.13  | 0    | 0    | 0    | 0    |
| Q201     | 0    | 0.34  | 0    | 0    | 0.72 | 0    |
| Q202     | 0.34 | 0.31  | 0    | 0.73 | 0    | 0    |
| Q203     | 0.31 | 0     | 0.3  | 0    | 7.36 | 7.62 |
| Q204     | 0    | 0     | 0    | 0.75 | 7.35 | 0    |
| Q205     | 0    | 0     | 0    | 0.7  | 7.36 | 0.25 |
| Q206     | 0    | 12.36 | 0    | 0.56 | 6.28 | 0    |
| Q207     | 0    | 13.6  | 0    | 0    | 13.6 | 0    |
| Q301     | 4.87 | 4.92  | 4.2  | 4.87 | 4.92 | 4.2  |
| Q302     | 1.63 | 3.99  | 0.92 | 1.63 | 3.99 | 0.92 |
| Q304     | 0.74 | 2.77  | 0    | 0.74 | 2.77 | 0    |
| Q305     | 2.32 | 4.93  | 1.69 | 2.32 | 4.93 | 1.69 |
|          |      |       |      |      |      |      |
|          |      |       |      |      |      |      |
|          |      |       |      |      |      |      |
|          |      |       |      |      |      |      |

## Integrated Circuits

| RECEIVER |      |      |      |     |      |       |  |  |  |  |
|----------|------|------|------|-----|------|-------|--|--|--|--|
| Pin      | IC1  | IC2  | IC3  | IC4 | IC5  | IC101 |  |  |  |  |
| 1        | 2.35 | 13.6 | 0    | 5   | 0    | 5.59  |  |  |  |  |
| 2        | 2.39 | 0    | 5    | 5   | 0    | 5.05  |  |  |  |  |
| 3        | 1.63 | 8    | 0    | 0   | 5    | 5.28  |  |  |  |  |
| 4        | 4.93 |      | 0    | 5   | 0    | 5.63  |  |  |  |  |
| 5        | 0    |      | 0    | 5   | 0    | 4.43  |  |  |  |  |
| 6        | 0    |      | 5    |     | 4.08 | 4.43  |  |  |  |  |
| 7        | 4.92 |      | 4.96 |     | 0    | 4.43  |  |  |  |  |
| 8        | 3.52 |      | 0    |     | 5    | 5.63  |  |  |  |  |
| 9        | 0    |      | 0    |     |      | 2.15  |  |  |  |  |
| 10       | 0    |      | 0    |     |      | 0.78  |  |  |  |  |
| 11       | 0    |      | 0    |     |      | 1.59  |  |  |  |  |
| 12       | 4.9  |      | 0    |     |      | 0.58  |  |  |  |  |
| 13       | 0    |      | 0    |     |      | 5.21  |  |  |  |  |
| 14       | 0    |      | 0    |     |      | 0     |  |  |  |  |
| 15       | 3.76 |      | 0    |     |      | 0     |  |  |  |  |
| 16       | 0    |      | 0    |     |      | 1.71  |  |  |  |  |
| 17       |      |      | 5    |     |      |       |  |  |  |  |
| 18       |      |      | 0    |     |      |       |  |  |  |  |
| 19       |      |      | 5    |     |      |       |  |  |  |  |
| 20       |      |      | 5    |     |      |       |  |  |  |  |
| 21       |      |      | 0    |     |      |       |  |  |  |  |
| 22       |      |      | 0    |     |      |       |  |  |  |  |
| 23       |      |      | 5    |     |      |       |  |  |  |  |
| 24       |      |      | 5    |     |      |       |  |  |  |  |
| 25       |      |      | 5    |     |      |       |  |  |  |  |
| 26       |      |      | 2.07 |     |      |       |  |  |  |  |
| 27       |      |      | 2.59 |     |      |       |  |  |  |  |
| 28       |      |      | 5    |     |      |       |  |  |  |  |

Integrated Circuit Voltages (Receive)

Integrated Circuits

| TRANSMIT |      |      |      |      |      |       |  |  |  |  |
|----------|------|------|------|------|------|-------|--|--|--|--|
| PIN      | IC1  | IC2  | IC3  | IC4  | IC5  | IC101 |  |  |  |  |
| 1        | 2.35 | 13.6 | 0    | 0.58 | 0    | 0     |  |  |  |  |
| 2        | 2.39 | 0    | 5    | 0.58 | 0    | 0     |  |  |  |  |
| 3        | 1.65 | 8    | 0    | 0    | 5    | 0     |  |  |  |  |
| 4        | 4.93 |      | 0    | 0.34 | 0    | 0     |  |  |  |  |
| 5        | 0    |      | 0    | 5    | 0    | 0     |  |  |  |  |
| 6        | 0    |      | 0.34 |      | 4.08 | 0     |  |  |  |  |
| 7        | 4.92 |      | 4.92 |      | 0    | 0     |  |  |  |  |
| 8        | 3.52 |      | 0    |      | 5    | 0     |  |  |  |  |
| 9        | 0    |      | 0    |      |      | 0     |  |  |  |  |
| 10       | 0    |      | 0    |      |      | 0     |  |  |  |  |
| 11       | 0    |      | 0    |      |      | 0     |  |  |  |  |
| 12       | 4.91 |      | 0    |      |      | 0     |  |  |  |  |
| 13       | 0    |      | 0    |      |      | 0     |  |  |  |  |
| 14       | 0    |      | 0    |      |      | 0     |  |  |  |  |
| 15       | 3.76 |      | 0    |      |      | 0     |  |  |  |  |
| 16       | 0    |      | 0    |      |      | 0     |  |  |  |  |
| 17       |      |      | 4.98 |      |      |       |  |  |  |  |
| 18       |      |      | 4.95 |      |      |       |  |  |  |  |
| 19       |      |      | 4.98 |      |      |       |  |  |  |  |
| 20       |      |      | 0    |      |      |       |  |  |  |  |
| 21       |      |      | 0    |      |      |       |  |  |  |  |
| 22       |      |      | 0    |      |      |       |  |  |  |  |
| 23       |      |      | 4.98 |      |      |       |  |  |  |  |
| 24       |      |      | 4.98 |      |      |       |  |  |  |  |
| 25       |      |      | 4.98 |      |      |       |  |  |  |  |
| 26       |      |      | 2.07 |      |      |       |  |  |  |  |
| 27       |      |      | 2.59 |      |      |       |  |  |  |  |
| 28       |      |      | 5    |      |      |       |  |  |  |  |

Integrated Circuit Voltages (Transmit)

## 9. PARTS LIST

7350-UE5/0808U\_2.SCH

Revised: September 7, 2009

Revision:

Bill Of Materials September 7, 2009 14:30:48

| Item | Quantity | Reference  | Part          |
|------|----------|--|---------------|
| 1    | 20       | C1, C40, C47, C48, C49, C51, C52, C106, C201, C216, C217, C218, C221, C225, C227, C235, C237, C238, C239, C240 | 470P          |
| 2    | 13       | C2, C11, C108, C317, C550, C551, C552, C553, C554, C555, C556, C557, C558                                      | 1U/Y5V 0805   |
| 3    | 6        | C4, C127, C224, C232, C234, C236   | 5P            |
| 4    | 16       | C5, C7, C8, C12, C37, C44, C103, C107, C121, C126, C203, C207, C243, C307, C312, C322                          | 102P          |
| 5    | 1        | C9   | 475P/1206     |
| 6    | 14       | C13, C19, C29, C36, C41, C42, C46, C53, C67, C102, C111, C112, C117, C546                                      | 104P          |
| 7    | 1        | C15  | 0.33U/T       |
| 8    | 4        | C16, C17, C21, C241  | 103P/X7R      |
| 9    | 2        | C18, C202  | 106P/1206     |
| 10   | 1        | C20  | 473P/X7R 0805 |

| Item | Quantity | Reference                           | Part            |
|------|----------|-------------------------------------|-----------------|
| 11   | 7        | C30,C31,C32,C115,C122,<br>C308,C524 | 100P            |
| 12   | 1        | C33                                 | 47U/16V/EC/SMT  |
| 13   | 1        | C34                                 | 100U/16V/EC/SMT |
| 14   | 1        | C35                                 | 4.7U/1206       |
| 15   | 4        | C43,C50,C120,C223                   | 22P             |
| 16   | 3        | C45,C116,C523                       | 47P             |
| 17   | 1        | C101                                | 1P              |
| 18   | 1        | C104                                | 1U/1206         |
| 19   | 1        | C105                                | 104P/X7R        |
| 20   | 1        | C110                                | 223P/X7R        |
| 21   | 1        | C118                                | 10U/1206        |
| 22   | 3        | C123,C214,C323                      | 15P             |
| 23   | 4        | C125,C212,C220,C311                 | 2P              |
| 24   | 2        | C204,C302                           | 18P             |
| 25   | 1        | C205                                | 335P/1206       |
| 26   | 1        | C206                                | 6P              |

| Item | Quantity | Reference                         | Part    |
|------|----------|-----------------------------------|---------|
| 27   | 4        | C208,C213,C230,C314               | 3P      |
| 28   | 2        | C210,C233                         | 10P     |
| 29   | 3        | C211,C305,C306                    | 7P      |
| 30   | 1        | C222                              | 12P     |
| 31   | 6        | C242,C300,C301,C309,C324,<br>C325 | 220P    |
| 32   | 1        | C303                              | 9P      |
| 33   | 2        | C304,C321                         | 8P      |
| 34   | 1        | CF1                               | CFU455E |
| 35   | 3        | D1,D5,D103                        | RLZ5.6B |
| 36   | 4        | D2,D3,D101,D202                   | RLS4148 |
| 37   | 1        | D4                                | RLZ4.3B |
| 38   | 2        | D6,D507                           | RLZ3.0B |
| 39   | 1        | D102                              | 1SS226  |
| 40   | 1        | D201                              | 1SS314  |
| 41   | 1        | D203                              | PTZ5.6B |

| Item | Quantity | Reference      | Part              |
|------|----------|----------------|-------------------|
| 42   | 3        | D205,D206,D303 | HVU131            |
| 43   | 2        | D301,D304      | 1SV229            |
| 44   | 1        | F101           | SAW FILTER        |
| 45   | 1        | IC1            | MB1504 SMT        |
| 46   | 1        | IC2            | UTC7808           |
| 47   | 1        | IC3            | PIC16C57C04 SMT   |
| 48   | 1        | IC4            | ELM7S32           |
| 49   | 1        | IC5            | 93C46 SMT         |
| 50   | 1        | IC6            | XC62AP5002MR      |
| 51   | 1        | IC101          | MC3361 SMT        |
| 52   | 1        | IC504          | TL064CD SMT       |
| 53   | 1        | J101           | BNC               |
| 54   | 2        | J902,J903      | PLUG 6PIN 2.54m/m |
| 55   | 1        | L101           | 12NH              |
| 56   | 1        | L102           | 47NH              |
| 57   | 1        | L103           | 2.2UH/BEAD        |



| Item | Quantity | Reference                                   | Part         |
|------|----------|---|--------------|
| 58   | 3        | L201 ,L203 ,L303                            | 27NH         |
| 59   | 1        | L202  | 15NH         |
| 60   | 1        | L204  | 0.45*1.5*6T  |
| 61   | 2        | L205 ,L206                                  | 5.6NH/0603   |
| 62   | 1        | L208  | 0.4*3*9T     |
| 63   | 1        | L210  | 0.65*1.1*4T  |
| 64   | 1        | L212  | 0.45*1.5*5T  |
| 65   | 2        | L213 ,L214                                  | 0.65*1.45*4T |
| 66   | 1        | L215  | 2.2UH        |
| 67   | 2        | L300 ,L301                                  | 1UH/BEAD     |
| 68   | 1        | L304  | 12NH/0805    |
| 69   | 2        | Q1 ,Q6                                      | A1037K       |
| 70   | 2        | Q2 ,Q14                                     | BCW68G       |
| 71   | 8        | Q4 ,Q9 ,Q10 ,Q11 ,Q15 ,Q201 ,<br>Q202 ,Q301 | BC847B       |
| 72   | 2        | Q7 ,Q103                                    | DTC114EK     |
| 73   | 1        | Q101  | 2SC5084      |

| Item | Quantity | Reference  | Part     |
|------|----------|--|----------|
| 74   | 1        | Q102   | 2SC4226  |
| 75   | 1        | Q104   | MMBTH10  |
| 76   | 1        | Q203   | DTA123JK |
| 77   | 5        | Q204 , Q205 , Q302 , Q304 , Q305                                   | 2SC5226  |
| 78   | 1        | Q206   | BFG35    |
| 79   | 1        | Q207   | 2SK2595  |
| 80   | 10       | R1 , R17 , R50 , R201 , R205 ,<br>R219 , R308 , R518 , R521 , R524 | 10K      |
| 81   | 8        | R3 , R47 , R118 , R516 , R523 ,<br>R525 , R528 , R531              | 100K     |
| 82   | 1        | R4   | OR       |
| 83   | 2        | R5 , R11   | 910R     |
| 84   | 5        | R8 , R20 , R30 , R103 , R318                                       | 2K2      |
| 85   | 2        | R9 , R22   | 820R     |
| 86   | 5        | R10 , R19 , R101 , R315 , R316                                     | 100R     |
| 87   | 1        | R13  | 3K       |
| 88   | 2        | R14 , R15  | 6K8      |

| Item | Quantity | Reference                                 | Part |
|------|----------|---|------|
| 89   | 2        | R16,R111                                  | 33K  |
| 90   | 2        | R23,R304                                  | 150R |
| 91   | 5        | R24,R41,R45,R107,R307                     | 4K7  |
| 92   | 1        | R29                                       | 12K  |
| 93   | 6        | R40,R46,R51,R52,R202,<br>R317             | 1K   |
| 94   | 5        | R48,R49,R117,R204,R216                    | 470R |
| 95   | 2        | R53,R102                                  | 1M   |
| 96   | 8        | R60,R61,R526,R527,R532,<br>R533,R534,R546 | 47K  |
| 97   | 1        | R104                                      | 220K |
| 98   | 2        | R105,R208                                 | 22K  |
| 99   | 1        | R106                                      | 1.5M |
| 100  | 3        | R108,R212,R311                            | 2K7  |
| 101  | 3        | R110,R112,R113                            | 560R |
| 102  | 2        | R114,R314                                 | 1K2  |
| 103  | 2        | R115,R217                                 | 470K |

| Item | Quantity | Reference      | Part          |
|------|----------|----------------|---------------|
| 104  | 3        | R116,R211,R213 | 22R           |
| 105  | 2        | R203,R218      | 27K           |
| 106  | 1        | R206           | 1.5K          |
| 107  | 1        | R207           | 220R          |
| 108  | 1        | R210           | 3K3           |
| 109  | 1        | R214           | 22R/0805      |
| 110  | 2        | R220,R313      | 56R           |
| 111  | 1        | R230           | 0.1R/0.5W/SMT |
| 112  | 1        | R301           | 10R           |
| 113  | 1        | R302           | 5K6           |
| 114  | 1        | R303           | 3K9           |
| 115  | 1        | R306           | 33R           |
| 116  | 1        | R309           | 330R          |
| 117  | 1        | R312           | 270K          |
| 118  | 1        | R517           | 15K           |
| 119  | 1        | R545           | 680R          |

| Item | Quantity | Reference    | Part             |
|------|----------|--------------|------------------|
| 120  | 1        | RP1          | 10K*4            |
| 121  | 2        | RV501, RV502 | 10KB SMT         |
| 122  | 1        | T2           | 0766             |
| 123  | 1        | VC1          | 20PVC/SMT        |
| 124  | 1        | VC2          | 5PVC/DIP         |
| 125  | 1        | VC3          | 5PVC/SMT         |
| 126  | 1        | VC4          | 10PVC/SMT        |
| 127  | 1        | VR1          | 100KB SMT        |
| 128  | 1        | VR101        | 47KB/SMT         |
| 129  | 1        | X1           | 12.8MHZ TCXO/SMT |
| 130  | 1        | X2           | 3.58MHZ 3X9      |
| 131  | 1        | X101         | 20.945MHZ UM1    |
| 132  | 1        | XF1          | 21M08B           |

## **8. PROGRAMMER INSTRUCTION**

Welcome to PC Programmer.

Please Read this file, before you first use the software.

### TABLE OF CONTENTS

1. Brief introduction
2. Before Installing
3. Install PC Programmer
4. INSTRUCTIONS
5. UnInstall PC Programmer

#### 1. Brief introduction

Welcome to PC Programmer. This program is designed to be used with the Interface Adapter.

The following equipment will be needed to program the Device:

- A. A computer to install this program with at least 2 MB available space in hard disk and a 9-pin male RS-232 serial port.
- B. Win 95, Win 98, Win ME or Win 2000 Operation System.
- C. Part of the Programming Kit
  - 1) An interface Adapter.
  - 2) A CD disk with the program, PC Programmer files

#### 2. Before Installing

Before You Run Setup, make sure that your computer meets the minimum requirements mentioned above, and read the Readme file(this file).

NOTE: If you firstly install PC Programmer in you system, the setup may update some system files on your computer , so you may run the setup again after your system be updated. Please follow the installation instruction on the screen.

#### 3. Install

TO install PC Programmer on your computer

- 1) Insert the CD.
- 2) Run Setup.exe
- 3) Follow the installation instruction on the screen.

Important: You cannot simply copy files from the CD to your hard disk and run PC Programmer . You must use the Setup program, which decompresses and installs the files in the appropriate directories.

## 4. INSTRUCTIONS

### 4.1 Connection

### 4.2 Start up PC Programmer

### 4.3 Edit Configuration

#### 4.3.1 Open/Recall/Upload Configuration file

#### 4.3.2 Edit Channel data

#### 4.3.3 Set Option item

#### 4.3.4 (Block)Cut/Copy/Delete/Paste

#### 4.3.5 Auto-Frequency edit

#### 4.3.6 Save a Configuration to disk

#### 4.3.7 Download Configuration to device

#### 4.3.8 Print a Configuration

### 4.4 Exit PC Programmer

### 4.1 Connection

1. Connect one side of Interface Adapter to the computer's serial port.

Never care the port number, the PC Programmer will locate it automatically.

2. Connect the other side of Interface Adapter to the Device's 9-pin male RS-232 port.

3. Connect power supply to device and LED will be light. The device will into PC\_programming mode automatically, please see the picture of below.

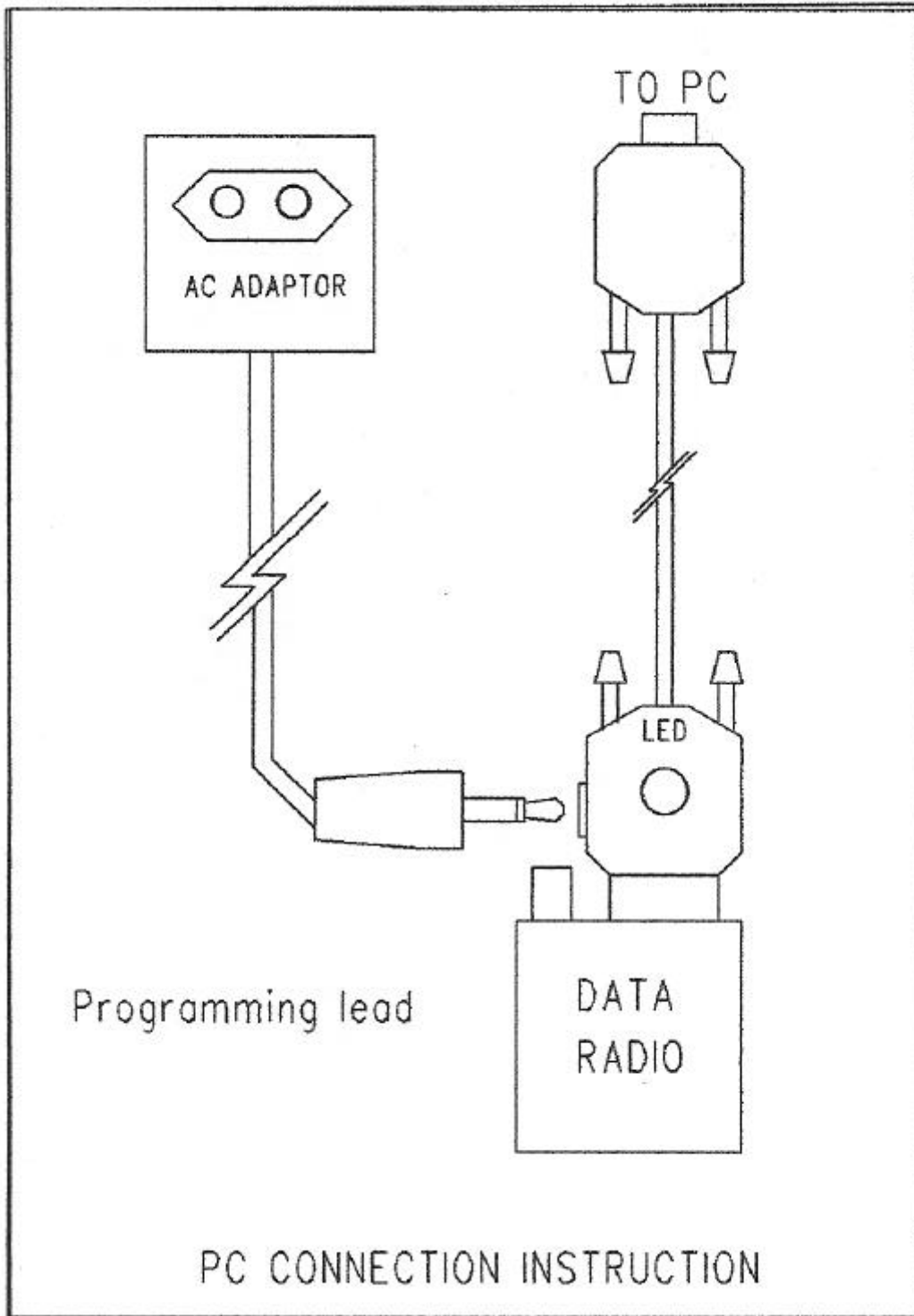

#### 4.2 Start up PC Programmer

1. Select 'Start', choose 'Programs', click on the '\*\*\* Serial PC Programmer' program.
2. When HD Serial PC Programmer is started, a main form will be shown after a greeting form.
3. There has a menu bar at the top of the main form, and a message box at the bottom.



NOTE: The program is menu driven for all pertinent commands. All the commands can be accessed by either key board or the left mouse button.

Access keys mainly used are:

'Tab' or 'Arrow' to move focus(or cursor)

'Enter' to active a focused command

#### 4.3 Edit Configuration

##### 4.3.1 Open/Upload Configuration file

To edit the configuration, please either

1) Recall an Existing Configuration by click on the 'Open' item in the File Menu, select the configuration file by click on or input its name then press 'Enter' key.

OR 2) Upload configuration data from a device by click on 'Upload' item in the Device menu. to a Configuration window .

Different Model's device Configuration can be opened and edited.

There are two fields in each Configuration window: system data and Channel data.

OR 3) Open an existing Configuration by click on the 'OPEN' item in the File Menu. A pop up window will be shown, select a file by arrow key or mouse then click 'OK'.

##### 4.3.2 Edit Channel data

1) Set focus to the Channel data field by move the mouse pointer.

2) Select a particular channel number to be edited by either the arrow key or click on it.

3) Pop up input window by either press 'Enter' key or double click on the selected channel number.

4) Use computer's cursor keys, Tab key, Enter key, arrow key or mouse to renew the channel data.

5) Click 'OK' button on the input window to accept the change or 'Cancel' to not change, and return back to Configuration Window.

##### 4.3.3 Edit Option item

1) To Edit Channel Option, Select a particular channel number in the Option View Window by either the arrow key or click on it, then Pop up the input window for Channel Option, 'Enter' key or double click on the selected channel number.

- 2) To Edit System Option, Pop up input window for System Option, click "SYSTEM" in the 'OPTION' menu.
- 3) To Edit Advanced Option, Pop up input window for Advanced Option, click "ADVANCED OPTION" in the 'OPTION' menu.
- 4) Use computer's cursor keys, Tab key, Enter key, arrow key or mouse to renew the Option Item.
- 5) Click 'OK' button on the input window to accept the change or 'CANCEL' to not change, and return back to Configuration Window.

#### 4.3.4 (Block)Cut/Copy/Delete/Paste

To select a block of channel data as source by either

- 1) Select start channel by arrow key, then while press 'Shift' key select end channel number by arrow key.
  - 2) Click on start channel, then while press 'Shift' key click on end channel number
  - 3) Press the left mouse button on start channel then move the mouse until reach the end channel number, release left mouse button.
- A) To Cut selected (block) Channel(s) either press 'Ctrl'+ 'X' or click 'CUT' item in Edit menu.
  - B) To Copy selected (block) Channel(s) either press 'Ctrl'+ 'C' or click 'COPY' item in Edit menu.
  - C) To Delete selected (block) Channel(s) either press 'Del(Delete)' key or click on 'DELETE' item in Edit menu.

After Cut or Copy, the data can be pasted to where you want.

- D) To Paste , select a channel as the start number of target , then either press 'Ctrl'+ 'V' or click on 'PASTE' item in Edit menu.

NOTE: Paste operation allows you to export data to any Configuration window opened.

#### 4.3.5 Auto-Frequency edit

This feature provide you with a quick Frequency set function.

To use this command after either

- 1) Click 'EDIT' Menu
- 2) Click on 'AUTOFREQ' item in 'EDIT' menu to pop up a input window.
- 3) Use computer's cursor keys, Tab key, Enter key, arrow key or mouse to set data.
- 4) Click 'OK' button on the input window to accept the change or 'CANCEL' to not change, and return back to Configuration Window.

#### 4.3.6 Save a Configuration to disk

- 1) Different configuration can be saved to disk.
- 2) Click on 'SAVE' item in 'FILE' Menu will overwrite an existing configuration file on your disk by current configuration.
- 3) Select 'SAVE AS' from 'FILE' Menu will save the current configuration by a name as you prefer.

#### 4.3.7 Download to device

To Download current Configuration to device, select 'DOWNLOAD' from sub menu under 'DEVICE' menu.

#### 4.3.8 Print a Configuration

Click on 'PRINT' item in 'FILE' Menu will send current Configuration to printer.

#### 4.4 Exit PC Programmer

To Exit PC Programmer, click on 'EXIT' item in 'FILE' Menu.

#### 5. UnInstall PC Programmer

To uninstall PC Programmer from your hard disk, select 'Start', choose 'Settings', click on the 'Control Panel', then find 'Add/Remove Programs' icon from the pop up window then double click on it, then find '\*\*\* Serial PC Programmer' from application list and click on it, then click on 'Add/Remove' button under application list, then follow the instructions on your screen.

# Federal Communication Commission Interference

## Statement

This equipment has been tested and found to comply with the limits for a Class B digital device, pursuant to Part 15 of the FCC Rules. These limits are designed to provide reasonable protection against harmful interference in a residential installation. This equipment generates, uses and can radiate radio frequency energy and, if not installed and used in accordance with the instructions, may cause harmful interference to radio communications. However, there is no guarantee that interference will not occur in a particular installation. If this equipment does cause harmful interference to radio or television reception, which can be determined by turning the equipment off and on, the user is encouraged to try to correct the interference by one of the following measures:

- Reorient or relocate the receiving antenna.
- Increase the separation between the equipment and receiver.
- Connect the equipment into an outlet on a circuit different from that to which the receiver is connected.
- Consult the dealer or an experienced radio/TV technician for help.

FCC Caution: Any changes or modifications not expressly approved by the party responsible for compliance could void the user's authority to operate this equipment.

This device complies with Part 15 of the FCC Rules. Operation is subject to the following two conditions: (1) This device may not cause harmful interference, and (2) this device must accept any interference received, including interference that may cause undesired operation