



GradoPlane 15



Operator's Manual



Content

General information	3
Safety information	4
FCC Warning.....	5
Charging the instrument	6
Keypad:	7
Indications in the display:	7
Starting up the instrument	8
Entering a grade.....	8
Tilt Function.....	9
Rotation speed	9
Mask mode.....	9
Scan Mode	9
Manual Mode.....	10
Operation with the remote control	10
Change of batteries of the remote control	10
Special functios	11
Remote Control Menu	12
Checking the calibration.....	13
Safety information:	13
Positions of laser warning labels	14
Specifications:	15
Warranty and service	16

General information

The GradoPlane 15 is a self levelling laser instrument for height measurement and surveying. A dual grade percentage of +/-10% can be entered directly and will be level automatically.

The instrument has the possibility to work with a laser spot or a scan beam. A high working range and a stable beam allows work with machine control units with rotation speed of 600 and 800 RPM.

The GradoPlane 15 instrument is waterproof and can be used outside in the elements.

An optional radio remote control is offered that can work all functions of the laser instrument and has the same display as the laser instrument.

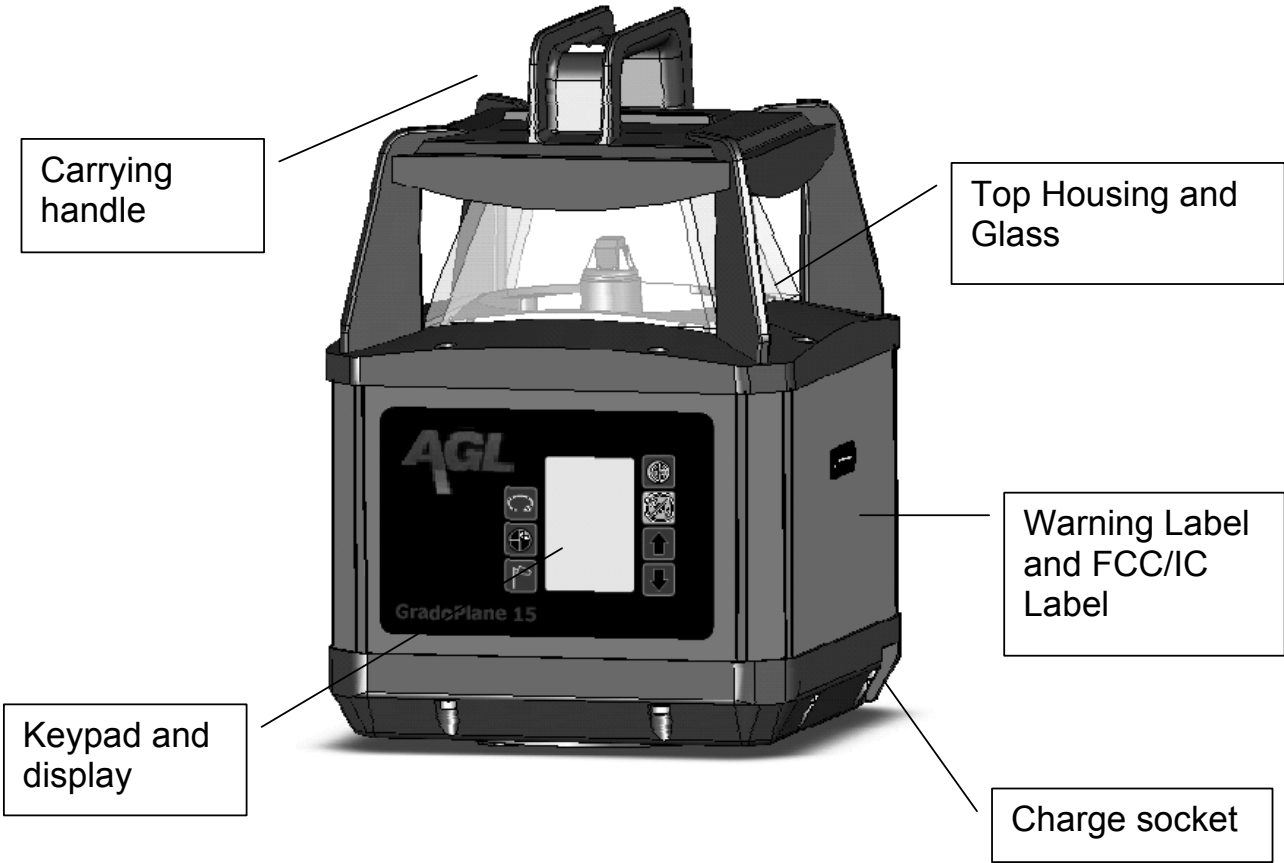

Safety information

Laser Safety

The GradoPlane 15 laser instrument is a class 2M laser according to EN 60825-1:2007. Follow the instructions on the warning labels which are shown in the following illustration:

GradoPlane 15:
635nm, $P \leq 1\text{mW}$
Laser Class 2M
(IEC 60825-1 2007)



Do not remove the attached warning labels. The manufacturer and its dealers are not liable for any defects and its consequences from this removal.

 Attention! Do not disassemble the instrument. Inappropriate repairs can cause hazardous laser radiation. Only AGL certified service centers are entitled to repair these products. In the case of inappropriate repair or modification malfunctions are possible also without external visible damages.

CE and disposal remarks

CE-marking (European regulation):

The instruments GradoPlane 15, including accessories, comply with the regulations of permission for low voltage and electromagnetic compatibility.

Attention: This instrument contains NiMH batteries. NiMH batteries must be recycled or disposed properly (WEEE-Reg.-Nr. DE 23874031).

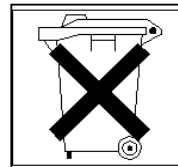



INFORMATION TO USER

This device complies with Part 15 of the FCC Rules. Operation is subject to the following two conditions: (1) This device may not cause harmful interference, and (2) This device must accept any interference received, including interference that may cause undesired operation.

This equipment has been tested and found to comply with the limits for Class B Digital Device, pursuant to Part 15 of the FCC Rules. These limits are designed to provide reasonable protection against harmful interference in a residential installation. This equipment generates and can radiate radio frequency energy and, if not installed and used in accordance with the instructions, may cause harmful interference to radio communications. However, there is no guarantee that interference will not occur in a particular installation. If this equipment does cause harmful interference to radio or television reception, which can be determined by turning the equipment off and on, the user is encouraged to try to correct the interference by one or more of the following measures.

- Reorient or relocate the receiving antenna
- Increase the separation between the equipment and receiver
- Connect the equipment into an outlet on a circuit different from that to which the receiver is connected
- Consult the dealer or an experienced radio/TV technician for help

Any changes or modifications not expressly approved by the party responsible for compliance could void the user's authority to operate the equipment.

To comply with FCC RF exposure compliance requirements, a separation distance of at least 20 cm must be maintained between the antenna of this device and all persons. This device must not be co-located or operating in conjunction with any other antenna or transmitter. Do not install in a location such that this device will be within 20 cm of all persons.

To comply with Industry Canada RF exposure compliance requirements, a separation distance of at least 20 cm must be maintained between the antenna of this device and all persons. This device must not be co-located or operating in conjunction with any other antenna or transmitter. Do not install in a location such that this device will be within 20 cm of all persons. For the hand held remote, do not transmit while close to the body or while in one's pocket or holster.

See Industry Canada RSS 102 for Radio Frequency (RF) Exposure Compliance of Radiocommunication Apparatus for exposure compliance.



Charging the instrument

The GradoPlane 15 laser has integrated rechargeable batteries. Connect the charger to an AC outlet and attach the plug at the charge socket. The battery symbol in the display is shown while the charging procedure is active. If the charging is finished, the battery shows three full blocks. The instrument has a charge controller inside, so not to overcharge, if the unit is not monitored. The maximum charging time is 5 hours.









Use the charger only in interior and dry rooms!



Attention: Avoid the use of the charger at fuel powered current generators. High voltage peaks may damage the charger.

Keypad:

	ON-OFF Switch
	Change the rotation speed of the laser
	Masking mode, turns off the laser beam in the selected sectors
	Wind sensitivity, decreases the sensitivity against vibrations, in the Display MRS (motion resistant system) is shown
  	Enters a grade in X and Y direction: X/Y button press once for X direction, press again for entering the Y value

Indications in the display:

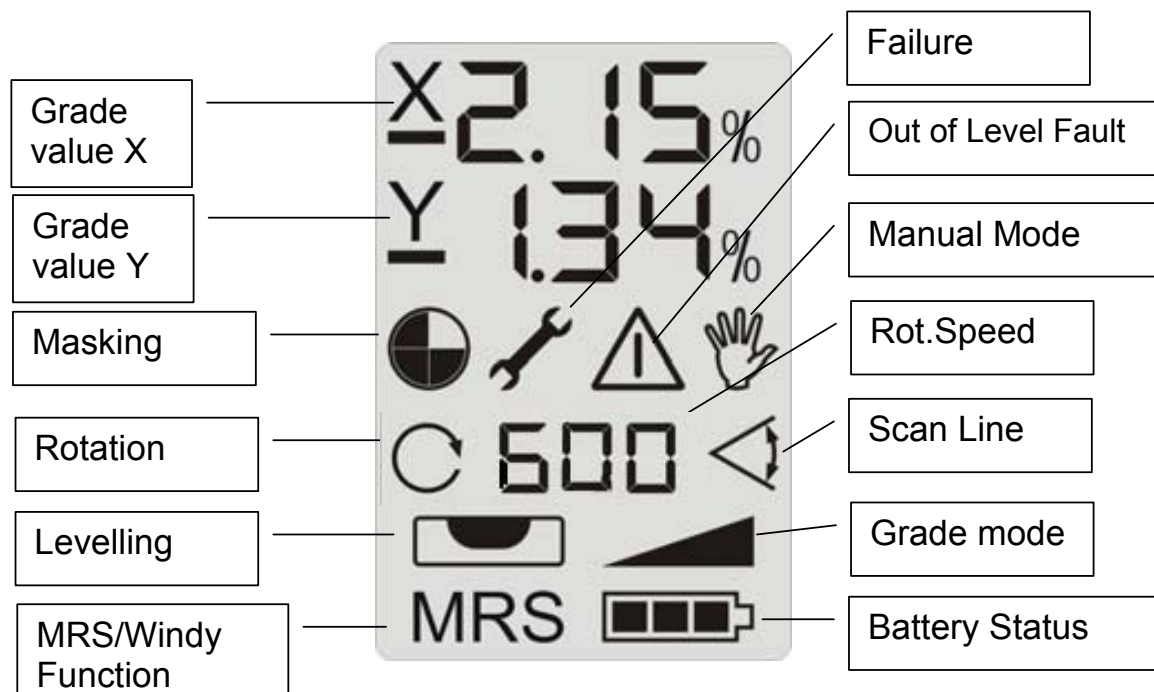

Starting up the instrument

Place the instrument on a tripod in a horizontal position. Turn the laser on with the Power Button button..



In the display a flashing level bubble is shown as long as the laser is self levelling. When this is finished the symbol turns off. The actual rotation speed and the battery condition are shown in the display.

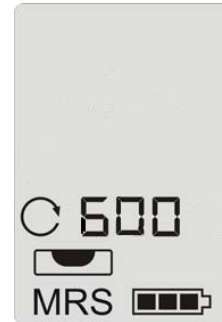

In this mode without an entered grade, the MRS/Windy function can be activated. This decreases the sensitivity against vibrations i.e. by wind.



Entering a grade

To enter a grade press the X/Y button

The instrument switches to the grade mode and the last used values are shown in the display.



When the work has to be done with these values, just wait until the instrument has self levelled.

To change the grade values press again the X/Y button. The x% is flashing and the grade can be changed with the arrow keys between -10% and +10%. To set the grade fast to zero; press both arrow keys simultaneously.

Now the grade can be entered in the Y direction. Pressing the X/Y button again enters this value and the instrument starts to self level. When the grade is reached the rotation of the heads starts.

In the grade mode it is not possible to activate the MRS/Windy mode.

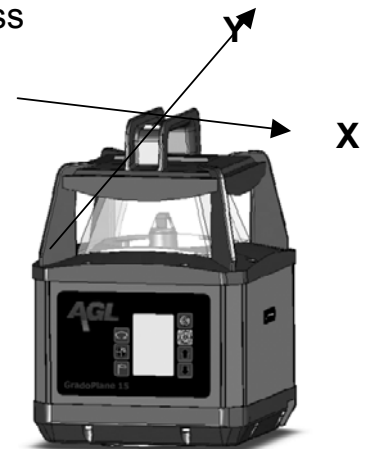

Tilt Function in grade mode

If the laser while working with grades is tilted or disturbed the laser will stop and in the display the failure symbol will flash.

By pressing the X/Y and rotation button for 2 seconds at the instrument or the remote control the levelling will be done again and the laser will again start to work. In this case please check the correct position of the laser instrument at you original bench mark. When the laser is working in horizontal mode without grades and the tilt alarm is active, it has to be turned off and on again.

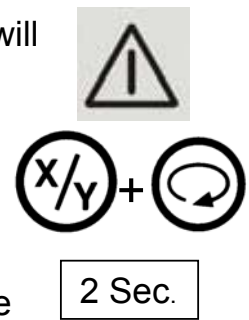

Rotation speed

The laser speed can be changed from 0 RPM, 600RPM to 800RPM. This offers a stable signal for a machine control systems. To work with a laser spot, press gain the rotation button. The laser spot then can be moved with the arrow keys.



Mask mode

In the mask mode the laser beam can be switched off in different sections. This function is used to avoid interference with different laser. It also avoids glare when in use e.g. at a motorway.

To turn on the mask function, press the mask button. The laser beam is masked in a range of 90°. By pressing again the button it changes to 180° and then to 270°.

With the arrow buttons the masked sector can be changed to the needed direction. In the scan mode and laser spot mode the mask function is deactivated.

To turn off the mask mode, the laser has to be switched off.



Scan Mode

In the scan mode the laser beam projects a line. This has an advantage when working interior as there is no receiver necessary. The line can be moved with the arrow keys. Pressing the button gain will increase the laser line length. To switch back to rotation press the rotation button..



Manual Mode

To use the instrument also for larger grades , e.g. roofs, it is possible to switch off the automatic levelling. To activate this manual mode press and hold the on button for at least 2 seconds. The display shows the hand symbol. Now the laser can be inclined manually and the fine alignment can be done with the arrow keys. Therefore press the X/Y button to move the x direction, press the button again to move the y direction. In the manual mode there is no tilt control for the position.



2 Sec.



Operation with the remote control

With the optional available remote control all functions of the laser can be controlled. Just the manual mode can not be activated to avoid an unintentional use. Turn on the remote control by pressing any key. The display shows the same symbols as the laser instrument.

If the laser has stopped in grade mode (Tilt control) the X/Y and rotation button can be pressed simultaneously for 2 seconds to confirm and restart the laser.

If a V and three bars are shown, there is no communication with the laser possible.

This can have the following reasons:

- The laser instrument is turned off
- The communication channel is different (see special functions)
- The distance to the laser is too large

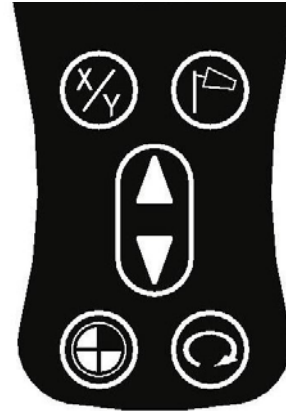

The remote control turns off after one minute without use. This time can be changed (see special functions). To switch off the laser and the remote control, hold both arrow keys pressed for 2 seconds.

Do not transmit while in pocket or when held close to the body.

Change of batteries of the remote control

The battery symbol on the remote refers to the batteries in the remote, not the laser. If the battery symbol is flashing, the batteries are empty. Take off the battery cover and replace the batteries with new ones. Always use two new batteries size AAA (LR03) from same type. Do not mix old and new batteries as their power will decrease.

Special functions:

The following functions can be adjusted in the GRADOPLANE 15:

- Maximum rotation speed
- Change of the communication channel
- Grade enter in percent or per mill

Menu GRADOPLANE 15: (Info -and Adjustment menu)

Buttons  and  pressed for 5 Seconds.

Info-Menu: Display **InF**

With **arrow keys** scroll Info's:

1. (GDP Programm Version) z.B. G-2440; 14.1
2. (BDNS Programm Version) z.B. b-0709; 12.1
3. Display Serial Number

Press  button for next step in the menu:

Rotation speed (Max. RPM): Display 600 or 800

With Arrow keys choose max RPM 600 or 800

Button  to store and change to next menu step

Com.-Channel remote control FB 2: Display e.g. Fb 5

With arrow keys choose channel 1 - 17.

(Default setting: channel 1)

Radio com. off: channel 0

Button  to store and change to next menu step

Function % (percent of grade) / ‰ (percent of mil)

Display symbol  flashing

For % -function press key **▲** (% - is standard)

For ‰ -function press key **▼**

Button  to store and end

Menu remote control:

To change the function in the remote control hold the arrow down key button pressed and then press the arrow up key multiple (as described below):

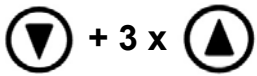

Serial number: Display e.g. 135350

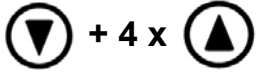

Software Version: Display e.g. 600527

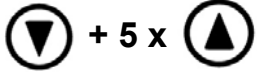

Com-channel: Display **CH 1-17** ↓

With Arrow keys choose 0 to 17

(FB2 default setting channel 1)

Button  to store and change to next menu step ↓

Automat. Power off. Display **APO** ↓

With Arrow keys choose from 5 to 600 seconds (default setting 60 Sec.)

Key  to store

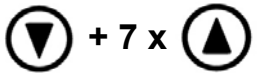

Display battery voltage RC

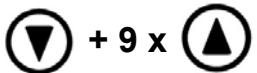

Radio Module test

Checking the calibration

The laser instrument should be checked, like all measure instruments, before use. The inspection can be carried out most easily by doing a reverse measurement.

Therefore do the following steps:

Set up the instrument onto a stable fixing.

Turn the laser on and let it level.

Mount the receiver in a fixed distance, i.e. at 100' (30 m), and move it onto the laser plane (display middle).

Now turn the instrument around each 90° and let the instrument level.

Measure in each case the difference to the first height.

If the deviation is smaller than $\pm 1/16''$ ($\pm 2\text{mm}$), the instrument is within the specification.

In case of larger deviations the instrument has to be calibrated.

Safety information:

Proper use:

The instrument is for aligning in the desired direction and the grade.

The instrument is used with a rechargeable NiMH battery.

The control of the instrument can be done with a radio controlled remote.

The unit may not be suitable for different application and may not function as intended with non-approved modifications or accessories. Opening the laser or making any other modifications may adversely affect the intended function.



Danger: The use in an aggressive or explosive environment (especially gas bearing pipes) is strictly prohibited!



Warning: Never short circuit the battery contacts with any metal parts or hold the battery under water. In case of a short circuit the battery can get extremely hot and there is a risk of injury and fire.



Warning: Never try to charge the battery with chargers that are not supplied from the manufacturer.

Positions of laser warning labels



[JCS1]



CLASS 2M LASER PRODUCT
WAVE LENGTH 630-680 nm
MAX. OUTPUT POWER ≤ 1 mW
LASER LIGHT: AVOID DIRECT EYE EXPOSURE.
CONFORMS TO IEC 60825-1:2007
COMPLIES WITH 21 CFR 1040.10 AND 1040.1
EXCEPT FOR DEVIATIONS PURSUANT TO
LASER NOTICE No. 50 DATED June 24, 2007
AGL, 2202 Redmond Road
THS Jacksonville, AR 72076 USA



[JCS2]

AGI 
AGI CORPORATION
2202 REDMOND RD.
P.O. BOX 189
JACKSONVILLE, AR 72076
Made in Germany
SN: HG 



Specifications:

GRADOPLANE 15 :

Laser Diode:	635nm
Laser class:	2M (IEC60825-2007)
Levelling range:	± 5°
Grade range:	grade ± 10% in X and Y direction
Working range:	1500 ft (450m)
Accuracy:	± 1/16" @ 100' or 10 arc sec (± 4,8 mm @ 100m) at 68°F (20°C)
Working temperature:	14°F / 122°F (-10°C / +50°C)
Rotations speed:	0 / 600 / 800 RPM
Battery:	NiMH-battery -12V DC current with optional cable
Working hours:	~20 h
Charging time:	maximum 5 hours
Protection class:	IP67 (water and dustproof)
Dim./weight:	7"x7"x10.2" / 7 lbs (176x176x260 mm / 3,2 Kg)

Charger :

Input:	100-240V AC / 47-63Hz
output:	12V / 2A



Use the charger only in interior dry rooms!!!

Design and specifications are subject to change without prior notice

Warranty and service

You have received a CE marked product that was checked in our works. In case of any claims please contact your AGL dealer or AGL Construction Lasers directly. In case of own attempts of repair as well as detectable improper treatment the claim for warranty is invalid. Please always use the original transport case for shipment.

The user is responsible for the regular checking of the instrument by the manufacturer or one of its authorized service center. A calibration interval of one year is recommended. The manufacturer and its representatives are not responsible for any damages resulting of using a maladjusted instrument. From that we recommend checking the instrument, like any other measuring instrument, before use (reverse direction measurement).



AGL Construction Lasers
2202 Redmond Rd.
Jacksonville, AR 72076
Tel.: (800) 643-9696
Fax: (501) 982-0880
www.agl-lasers.com