

TABLE OF CONTENTS

LIMITED WARRANTY STATEMENT	6
Introduction	10
Important Information	11
Check Accessories	11
Before You Start	13
Safety Instructions	14
Chapter 1. Getting Started	15
1-1 Cautions	16
1-2 Installing the RUIM Card	16
1-3 Using the Battery Pack	18
1-4 Phone Components	22
1-5 Function Keys	23
1-6 Display Indicators	24

Chapter 2. Basic Function	25
2-1 Turning the Phone On and Off	26
2-2 Making Calls and Answering Calls	26
Making Calls	27
Call Waiting	27
3Way Calling	28
Call Forwarding	28
Making Calls using the phone book in 2 ways	29
Redialing	29
Speed Dialing	29
Answering Calls	30
2-3 In-Call Operations	30
2-4 Writing Text	31
Using Traditional Text Input	33
Using T9 Text Input	34
Using Manner & Keypad Key Guard Mode	36
2-5 Phone Book Features	37

Chapter 3. Menu Functions	41
3-1 General Guidelines to Access Menu Functions	42
3-2 Phone Book	42
Add New	42
Search Name	44
Search Entry.....	45
Erase	46
Memory Status	47
3-3 Messages	48
Write Message	48
Inbox	50
Outbox	51
Draft	52
Erase Message	53
Settings	54
Voice Mail	58
3-4 Call History	59
Missed Calls	59
Received Calls	61
Dialled Calls	62
Erase History	63
Call Duration	64

3-5 Sound	65
Ring Type	65
Ring Tones	66
Ring Volume	67
Key Tone	68
Settings	69
3-6 Organizer	70
Alarm	70
Scheduler.....	72
3-7 Security	74
Restrict	74
Change Password	76
RUIIM Manager	76
Reset	77
Lock	78
3-8 Settings	79
Call.....	79
Display	80
Data Service	83
3-9 Game Pon Man Adventure	84
Chapter 4. Safety Guidelines	85
4-1 Safety Information	86



**LIMITED WARRANTY
STATEMENT**

ALCOMM

LIMITED WARRANTY STATEMENT

1. WHAT THIS WARRANTY COVERS:

ALCOMM offers you a limited warranty that the enclosed subscriber unit and accessories will be free from defects in material and workmanship, according to the following terms and conditions:

1) Product warranty : 12 months commencing from date of activation or 16 months from date of manufacture whichever is less.

Battery : 9 months commencing from date of activation or 12 months from date of manufacture whichever is less.

2) During warranty period, defective product is repaired or replaced by ALCOMM or its authorised service network free of charge.

All replaced parts, boards or equipment become property of ALCOMM.

3) Warranty for repaired or replaced product or part shall extend for the remaining warranty period for of the product or part.

4) ALCOMM is entitled to request to consumer to provide purchase receipt or other documents or information about date and place of purchase.

6) In order to derive benefits of this warranty in respect of any defects in the product, the consumer shall ship the product or part thereof at its cost to the authorised service center of ALCOMM. ALCOMM shall bear the cost of shipping the product or part thereof back to the consumer after the completion of the service under this limited warranty.

2. WHAT THIS WARRANTY DOES NOT COVER:

- 1) Defects or damage resulting from use of the product in other than its normal and customary manner.
- 2) Defect or damage from abnormal use, abnormal conditions, improper storage, exposure to moisture or dampness, unauthorized modifications, unauthorized connections, unauthorized repair, misuse, neglect, abuse, accident, alteration, improper installation, or other acts which are not the fault of ALCOMM, including damage caused by shipping, blown fuses, or spill of food or liquid.
- 3) Breakage or damage to antennas unless caused directly by defects in material or workmanship.
- 4) Alleged defects or malfunctions of the product if the Customer Service Department at ALCOMM was not notified by the consumer during the applicable limited warranty period.
- 5) Products, which have had the serial number, removed made illegible.
- 6) This limited warranty is in lieu of all other warranties, express or implied either in fact or by operations of law, statutory or otherwise, including but not limited to any implied warranty of marketability, merchantability or fitness for a particular use.
- 7) Damage resulting from use on non-ALCOMM approved accessories.
- 8) All plastic surface and all other externally exposed parts that are scratched or damaged due to normal customer use.
- 9) Products operated outside published maximum ratings.
- 10) Products used or obtained in a rental program.
- 11) Consumables (such as fuses)

ALCOMM
ALCOHOLIC BEVERAGE CONTROL BOARD
MEMORANDUM
DATE: _____
TO: _____
FROM: _____
SUBJECT: _____

Memo



Introduction

ALCOMM

Introduction

Dear customer,

Thank you for choosing ACH-700 CDMA mobile phone. As ALCOMM' s first CDMA 1x handset for entry level and new CDMA markets, ACH-700 has all the essential features that any new mobile user can ask for. ACH-700 has a stylish design with trimly soft edge and sharpness for a comfortable grip on the phone. The candy bar type phone is equipped with a variety of features as shown below that offers great value to your mobile experience :

ACH-700 Handset

950 mAh Li-Ion battery

Travel Charger

User Manual

Hand Strap

Cigar Lighter Adapter (Optional)

Ear Micro Phone (Optional)

Important Information

This user guide provides important information on the use and operation of your phone. Please read all the information carefully prior to using the phone for best performance and to prevent any damage to or misuse of the phone. Any unapproved change or modification will void your warranty.

Check Accessories

Your mobile phone comes with the following accessories : a travel charger, a rechargeable battery and a hand strap. Please verify your accessories are included.

Memo



Before You Start

ALCOMM

Before You Start

Safety Instructions

WARNING! To reduce the possibility of electric shock, do not expose your phone to high humidity areas, such as the bathroom, swimming pool, etc.

Always store your phone away from heat. Never store your phone exposed to temperatures less than -30°C or greater than $+60^{\circ}\text{C}$, such as outside during a snowstorm or in your car on a hot day. Exposure to excessive cold or heat will result in malfunction, damage and/or catastrophic failure.

Use caution when using your phone near other electronic devices. RF emissions from your mobile phone may affect nearby inadequately shielded electronic equipment. You should consult with manufacturers of any personal medical devices such as pacemakers and hearing aids to determine if they are susceptible to interference from your mobile phone. Turn off your phone in a medical facility or at a gas station. Never place your phone in a microwave oven as this will cause the battery to explode.



Chapter 1.
Getting Started

ALCOMM

1-1 Cautions

- ▶ Using the phone near receiving equipment(i.e., TV or radio) may cause interference.
- ▶ Keep your phone in a safe place when not in use.
- ▶ Use only the batteries, antennas and chargers provided by ALCOMM. Using unauthorized accessories could void your warranty.
- ▶ Only authorized personnel should service the phone and its accessories. Faulty installation or service may result in accidents and consequently void the warranty.
- ▶ Do not hold the antenna while the phone is in use.
- ▶ Do not use the phone in designated **no cellular phone use areas**.
- ▶ Do not expose the phone to high temperature or humidity.
- ▶ Avoid getting your phone wet. If the phone gets wet, turn the power off immediately and remove the battery. If the phone is non-functional, return it to the dealer for service.
- ▶ Avoid shock or impact on the phone.

1-2 Installing the RUIM Cards

- ▶ Keep all miniature RUIM cards out of the reach of small children.
- ▶ The RUIM card and its contacts can easily be damaged by scratches or bending, so be careful when handling, inserting or removing the card.
- ▶ Before installing the RUIM card, always make sure that the phone is switched off and then remove the battery.

1. With the back of the phone facing you, press the release button 1. Slide the battery off the phone 2.

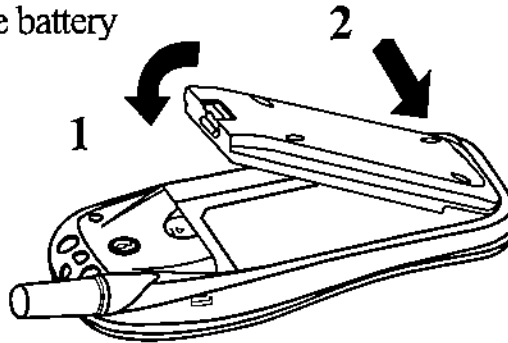

2. Release the RUIM card holder by sliding it to the right.

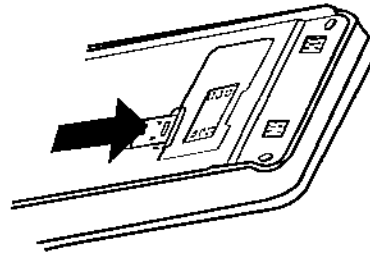

3. Insert the RUIM card ensuring that the bevelled corner is on the bottom right and the golden contact area is facing downwards.

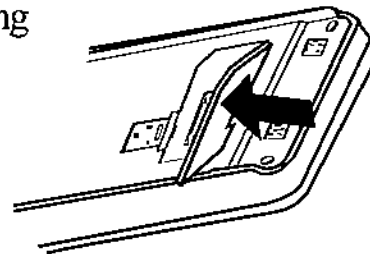

- Slide the card holder to the left to lock the card in its place.

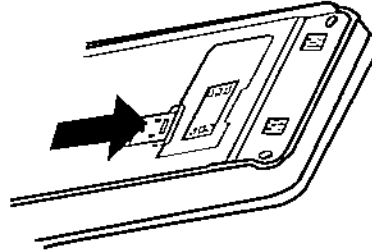

- Place the battery on the back of the phone and slide it up the body of the phone until it locks into place.

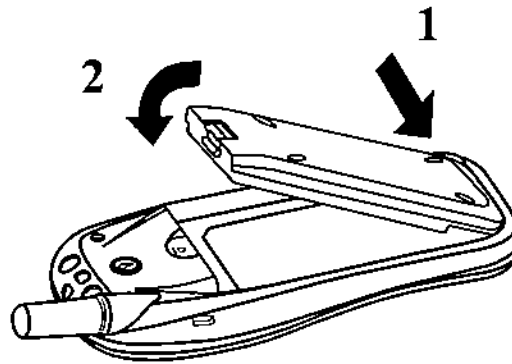

1-3 Using the Battery Pack

Charge the battery fully before the initial use of the phone.

The phone comes with a rechargeable battery. Keep the battery charged while not in use in order to maximize and standby time when using the phone.

Installing the Battery

To install the battery, insert the bottom of the battery into the opening on the back of the phone. Then, push the battery down and push the latch down until it click

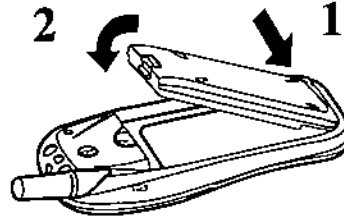

Removing the Battery

Turn the power off. (If power is on, a loss of stored number and messages may occur).

By lifting removal button the battery will become detached.

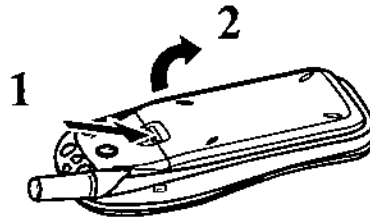

Battery Charge Level

The battery charge level is shown at the top right of the LCD screen.

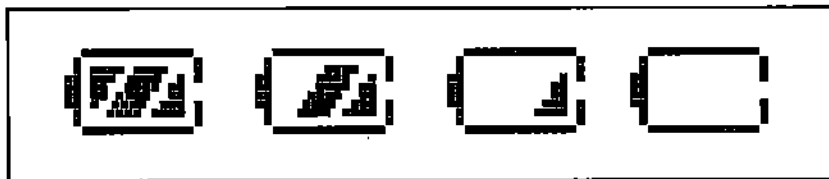

When the battery charge level becomes low, the battery sensor will alert you by sounding an audible tone. If the battery charge level becomes exceedingly low, the phone will automatically switch off and any function in progress will not be saved.

※ If the battery runs out during a call, call may terminate and the phone may turn off automatically.

Using the Travel Charger

Warning! Use only the travel charger provided with the phone. Using wrong charger may cause damage to your phone and battery and invalidate the warranty.

- 1) Connect the lead of the charger to the bottom of the phone.
- 2) Plug the charger into a wall outlet.

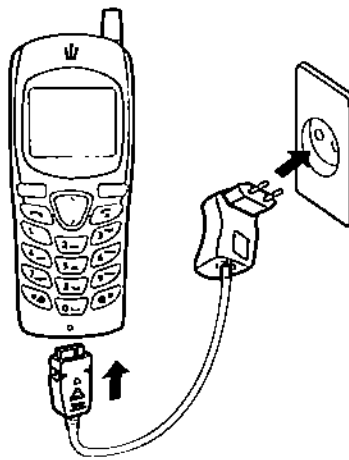

- The charger should operate on a AC 220V source. (Check voltage of the charger)
- The phone can be used while charging if it is switched on.
- Fully charging empty battery with the travel charger takes approximately 3hours.
- If charging is not displayed, wait for a while, disconnect the charger plug it in again and retry. If charging still fails, contact your dealer.

- 3) When the battery is fully charged, the bar stops scrolling. Disconnect the charger from the AC outlet and phone. The red light of the charger indicates that the battery is being charged. If charging is completed, the light will turn into green.

Caring for the Battery







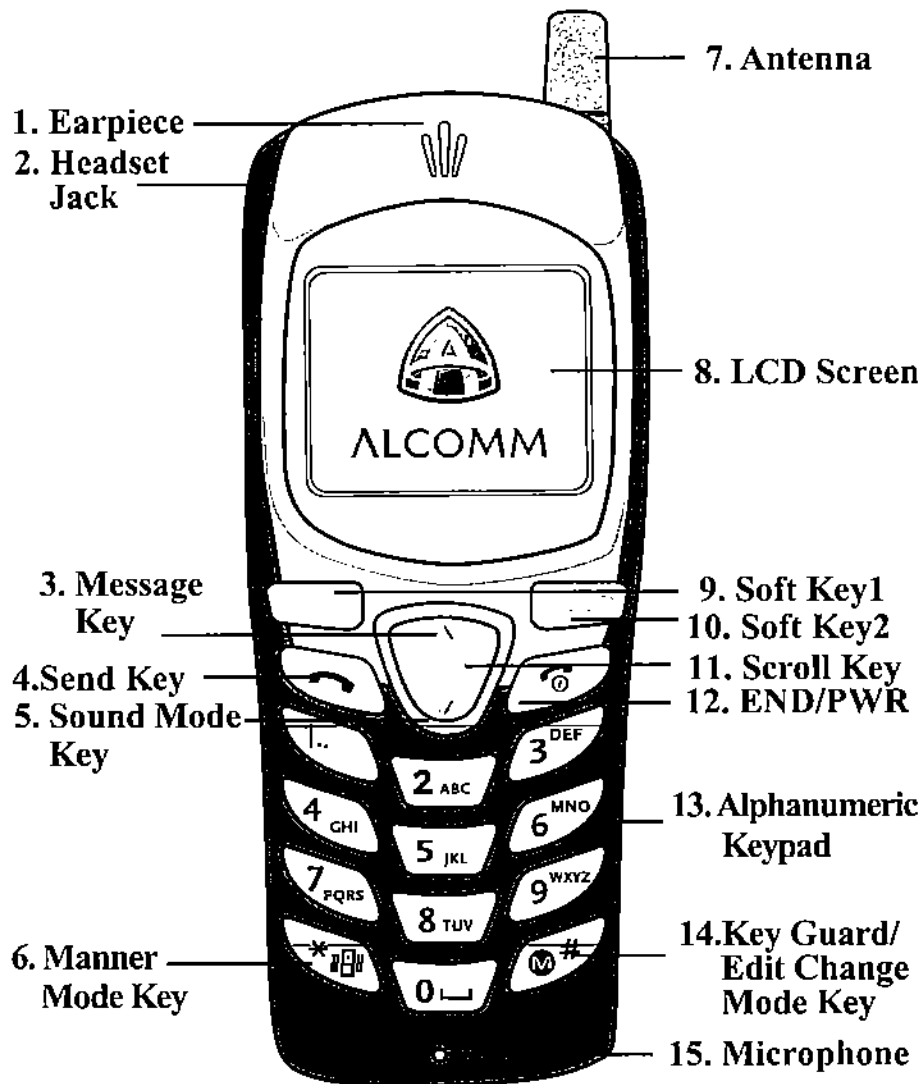

- 1) Do not use unauthorized battery. It may cause damage to or explosion of the battery.
- 2) Use only ALCOMM batteries and chargers specific to your model of phone. ALCOMM's chargers are designed to maximize battery life.
- 3) Do not disassemble or short-circuit the battery.
- 4) Keep the battery's metal contacts clean.
- 5) Recharge the battery if it has not been used for a long time to maximize battery life.
- 6) Do not expose the battery charger to direct sunlight or use it in areas of high humidity, such as the bathroom.
- 7) Do not leave the battery in hot or cold places as it may deteriorate battery performance.
- 8) Your battery life may vary by location, use patterns, etc.
- 9) Long backlight settings of the phone may affect battery life, talk, and standby times.
- 10) Leaving the battery in hot or cold places, such as in a closed car in summer or winter conditions, will reduce the capacity and lifetime of the battery. Always try to keep the battery between 15°C and 25°C. Batteries' performance is particularly limited in temperatures well below freezing.
- 11) Do not dispose of batteries in a fire!

1-4 Phone Components

The following shows key components of your mobile phone.











1-5 The Function Keys

- ①  Allows a user to place, answer calls or to see recent call list.
- ②  Press to terminate a call, return to initial screen, or turn the phone on/off.
- ③ 
 This Scroll Key allows quick access to notification messages.
 Up scroll key for Messages and down scroll key for Sound on initial screen.
- ④ 
 - Soft Key 1, upper left corner, right above Send key.
 Press to access the menu or function.
 - Soft Key 2, upper right corner, right above End key.
 Press this key once in a menu to go back one level.
 Press this key on initial screen to search name or use as a clear key.
- ⑤ 
 In standby mode, set the manner mode(vibration) by pressing and holding the  key.
 - In T9 edit mode, toggle candidate words.
- ⑥ 
 In standby mode, set key guard function by pressing and holding the  key about 3 seconds.
 - In edit mode, change input mode.
- ⑦  Press this key for space in edit mode.

1-6 Display Indicators

The phone screen displays several on-screen icons which appear when the phone is powered on.

	<p>Signal Strength Current signal strength-the more lines the stronger signal</p>
	<p>Message New text or voice message</p>
	<p>Battery Battery Charge Level-the more blocks the stronger the charge.</p>
	<p>Alarm Appears when alarm is set.</p>
	<p>Service Indicator Appears when phone is in operational service network.</p>
	<p>Manner Mode Manner Mode On- phone will vibrate when call is received.</p>
	<p>Digital Icon CDMA Mode</p>
	<p>Phone Lock Icon</p>



Chapter 2. Basic Functions

ALCOMM

2-1 Turning the Phone On and Off

Turning the Phone On

1. Install a charged battery pack or connect the phone to an external power source such as travel charger.



2. Press  for a few seconds until the light is on.
 - ※ Like any other radio device, avoid any unnecessary contact with the antenna while our phone is on.
3. If the phone requests a PIN code : The PIN code is usually supplied with the UIM card.
 - ▶ Key in the PIN code (displayed as ****), and press OK.

Turning the Phone Off



1. Press and hold  until display screen turns off, then release the key.

2-2 Making Calls and Answering Calls

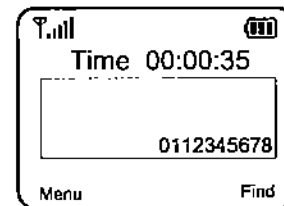
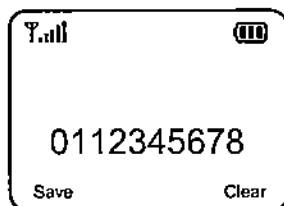
When you make a call, follow these simple steps:



Making Calls

1. Make sure the phone is turned on.
 - ▶ If not, press  and hold for few seconds.
2. Key in the phone number including the area code.
3. Press Clear to delete the digit to the left
4. Press  and wait for the answer.
5. Press  to end the call(or to cancel the call attempt).



If outgoing calls are in restricted mode, Outgoing call is restricted. message displays on your screen.

You can only dial phone numbers saved in Emergency list.

- ▶ If you want to turn off this function, look at Security in Menu.



Call Waiting

Your cellular service may offer a call waiting function. While a call is in progress, you may hear beeps indicating another incoming call. When call waiting is enabled, you may put the active call on hold while you answer the other incoming call. Check with your cellular service provider for information about this function.

1. Press  to receive a waiting call.
2. Press  again to switch between calls.
3. Press  to end one of the calls.

3 Way Calling

This feature allows you to make a call without hanging up the other line. Check with your cellular service provider for information about this function.

1. Dial desire number and press 
2. If you want to go back to the initial call, wait until 2nd person hangs up the phone, otherwise press  to end both calls.

Call Forwarding

This feature allows you to transfer the receiving calls to the other number that you entered.

Check with your cellular service provider for information about this function.

Making Calls using the phone book in 2 ways

1. In standby mode, press  search
2. Enter desired name and press search



OR

1. Press Menu and Select Phonebook
2. Scroll to select Search name or entry.

※ You can also make the calls by dial in the last four digit number and press 

Redialing

To redial one of the last 30 phone numbers you have dialed, answered or missed:





1. Press  key in standby mode
2. Scroll with navigation key to the desired phone number or name, and press 

Speed Dialing

If the phone number has been assigned to a number key for speed dialing, you can speed dial the number in the following way:



1. Press and hold the corresponding number key until dialing message appears.

Answering Calls

1. In standby mode, press any key except .
Press  to end the call.
2. To make ring tone silent press  once.
3. To reject the call without answering, press  twice.



2-3 In-Call Operations

Depending on the situation of the phone call, following operations can be performed during a call by pressing  or .

Menu or  **Find**.

Menu

- ▶ **Messages** :To send messages
- ▶ **Mute** :The person you are calling can not hear your voice
- ▶ **Send Phone** :Send out your phone number
- ▶ **Silence** :Key tone sline

Find

- ▶ To find the phone number you want.

2-4 Writing Text

You can key in text in two different ways, using the traditional text input or predictive text input method called T9 text input.

Input Mode

T9 Text Input provides four modes for entering text, numbers, special characters, and punctuation.

► **Abc(Multi-Tap) Mode**

There are three different mode such as Abd, ABC and abc mode. Use Abc mode to add words in traditional text input mode. The default is Abc mode.

► **T9 Mode**

Type text using one keystroke per letter. The phone translates keystrokes into common words by using the letters on each key and a compressed database.



► **123(Numbers) Mode**

Type numbers using one keystroke per number.

To change to 123 mode in a text entry field, press  and hold for few seconds until 123 mode is displayed on top right corner.

Symbol Mode

Insert special characters and punctuation.



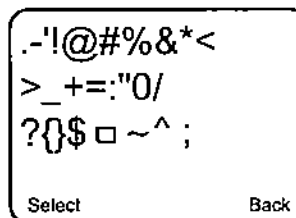

In 123(Number)mode, you can switch to symbol mode by pressing  once. You may use any of the 30 special characters. When the cursor is located where you want the special character, switch to Symbol mode. Press  key in number mode and press  to select the desired character.







Using Traditional Text Input

When writing text, press the key marked with the desired letter one or more times until the letter appears. Note that not all available characters are visible on the keypad.

Use the following functions to edit the text:



- To add a space, press  key
- To add a punctuation mark or special character, press and  hold when indicator at the top of the display is in  mode, press  one more time.

Use scroll key to select desired punctuation mark or special character.

- To move the cursor left or right, press  respectively
- To delete the character to the left to the cursor, press  Clear key.
- To switch between upper and lower case, press  key to change indicator at the top right of the display.
- To switch between letters and numbers, press and hold  key.
- To key in a letters which is under the same key as the previous one, press scroll key up and down (or wait until the cursor appears) and key in the new letter.

Using T9 Text Input

T9 text input offers an easy way to write text. You can edit and input Banner, Scheduler, Short Message and Phone Book using T9 Text Input.

1. Key in the desired word by pressing each key once for one letter.
2. Press  key to select the desired word and press  key and start writing the next word.

Changing Letter Case

There are three options for selecting letter cases : Press  key to change the following option.

Initial Cap (t9 Abc)

Only the first letter is capitalized

Caps Lock(t9 ABC)

All subsequent letters are capitalized.

















Lower Case(t9 abc)

Change letter case to lower case

Examples Using T9 Text Input



Typing In T9 Mode



To use T9 mode while in a new message, follow the these steps:

1. Press  key to change the letter cases
 2. Press    
 3. Press  to complete the word and add a space
 4. Press          
 5. Display: Call the office.
- ※ Press  to select other desired word on each word.



Key Functions

 **Option:** Press to scroll and select a mode through menus.

 ~  (Type Text): In t9 mode, press one key per letter to enter text.

 ~  (Type Numbers): In 123 (Numbers) mode, press once to enter numbers.

 (Next): In t9 mode, press to display other matching words.

 (Symbols) : In  mode on top right corner, press to insert punctuation in a word and complete a sentence.

 : In t9 mode, press to complete a word and insert a space.

 : Press to move the cursor.

 **Clear :** Press to delete a single space or character.
Press and hold to delete entire words.

Using Manner & Keypad Key Guard Mode

Manner Mode

Use manner mode in a public place.

1. In standby mode, activate manner mode by pressing the  key and hold for few seconds.

Vibrate
mode enabled

- ▶ When manner mode is set, there are no tones in the keys and the phone vibrates instead of ringing.
2. In standby mode, deactivate manner mode by pressing the  key and hold for few seconds until release message appears.

Key Guard Mode(Quick)

To prevent unintentional dialing.

1. To activate key guard mode, in standby mode, press  and hold the key (for 3 seconds)

Key guard
mode enabled

- ▶ When keyguard mode is set any keys other than  will not work.

- ※ To release the key guard mode, press the  (for 3 seconds)

When key guard mode is released, **Key Guard Mode Disabled** is displayed on the LCD screen.

2-5 Phone Book Features

Phone Book Memory

You can store names and phone numbers in the phones memory(internal phone book) and in the RUIM cards memory(RUIM phone book). You can only use one memory at a time. To access the phone book, press **Menu** and **Select** the phone book. To access the phone book during the a call press **Find** and enter the search name. Also, it has Numeric menu(Pause) Features.

- ▶ The phones internal phone book can store 300 names with 3 numbers per name.
- ▶ The phone supports RUIM cards and memory depends on the card.

Numeric menu(Pause) Features in your Phone Book

1. Numeric Menu: When you call automated systems(such as voice mail or credit billing numbers), you often have to enter a series of numbers.

Instead of entering these numbers by hand, you can store the numbers in your phonebook separated by special characters(eg. **P**, **T**) called pauses.

There are three different pauses that you can use when storing a number:

▶ **Time Pause(T)**





The phone will wait two seconds before sending the next string of digits.

▶ **Hard Pause(P)**







The phone will stop dialing until the beep sound. After the beep sound resume to advance to the next number.

▶ **One Hyphen(-)** To differentiate the area code, country code and etc.

2. Storing a Number with Pauses





- 1) Enter the phone number.
- 2) Press 
- 3) Select one of the following:
 - ▶ Press Time pause
 - ▶ Press Hard pause
 - ▶ One hyphen
- 4) Enter additional number(s) (e.g., pin number or credit card number).
- 5) After entering additional number(s), press  **Save** to save this number with pauses.
- 6) The phone will prompt you for the memory location where the number will be saved.
Press  **Next** to automatically store the number in the first available memory location.
You also have the option to enter a specific three-digit memory location number.
- 7) Enter a name for the phone number. If you do not want to enter a name, go to the next step.
- 8) Select your desired label type **Mobile, Home, Office** using 
- 9) Press  **Select**. A confirmation message **Stored in entry 000** displays on the phone.

Edit the Existing Phone Numbers and an E-mail Address in your Phone Book

1. From the initial screen press  **Find**, the Search name appears.
2. Enter the name and press  **Find**.
3. Press  to highlight the label type.
4. Select the desired unused label type or desired edit label type by using .
5. Press  **Edit** to enter the additional phone number, edit the existing number or e-mail address as appropriate.
 ※ You can also change the default ring type in this step.
6. Press  **Save**.

Retrieving Numbers

Retrieving by Name Search



1. Press  **Find**.
2. Enter the character(s) that you want to search for (such as the first letters of the name.) and press  **Find**.
3. You will see a list of matches
4. Press  **Detail** to see specifics in that memory location, or press  to place the call.







Chapter 3. Menu Functions

ALCOMM

3-1 General Guidelines to Access Menu Functions

1. Press  **Menu**. Seven menu items are in the menu features.
2. Press  **Key** to go through the list of menu features.
3. When desired menu appears on the screen press  **Select**.

The sub-menu will appear on the screen.



4. Highlight the sub-menu item that you want using scroll key and press  **Select**.
5. Adjust your setting using the   **or** 

3-2 Phone Book(Menu)

You can save mobile phone numbers and so on, up to 300

Add New(Menu)

entries.

1. Press  **Menu**.
2. Press  **Select**.
3. Press  **Add new**.

4. Highlight the desired phone book and Press  **Select**.

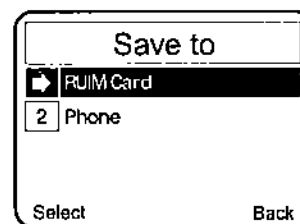
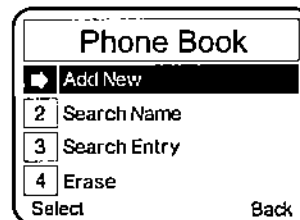

5. Enter the phone number,
then press **Next**.

Add New

Number :

0115682316

Next Clear

6. Enter the entry number or
press **Next** to select the
memory location number.

Entry : 001

Next Back

7. Enter the desired name
and press **Next**.

[001] abc

Name :

Next Clear

8. In case of storing the numbers
in phones memory, scroll
the desired label type using
 and press **Select**.

Label

Mobile ✓

Home



Office

Select Back

※ In case of RUIM, you can only store one phone number
per name.

Search Name(Menu)

To search for a phone number by name.

1. Press  **Menu** .
2. Press  **Select**.
3. Press  **Search Name**.

Phone Book	
1	Add New
	Search Name
3	Search Entry
4	Erase
Select	Back

4. Enter the desired character(s) and press  **Find**.

A list of matching names is displayed.

Scroll desired name.

If there is no matching name,
the message **No matching name...**



is briefly displayed and the phone

will return to the Search Name screen.

Search Name	abc
Name :	
	Tom
Find	Clear

Search Entry (Menu)



To search for a phone number you have stored in the Phonebook by entry number.

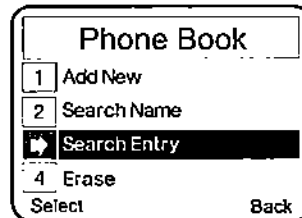

1. Press  **Menu**.
2. Press  **Select**.
3. Press  **Search Entry**.

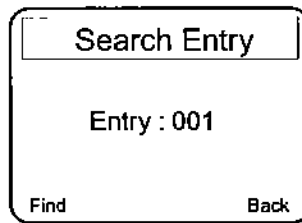



4. The display prompts you to enter the entry number on the display screen.
5. Enter the desired entry number you want to find and press  **Find**.





6. If you press  **Find** without entering an entry, you will view a list of all entries that you called.
- ※ At any entry, you may move to another entry by pressing the Up/Down key. If you press  **Detail**, you can edit detail information of that entry.

Erase(Menu  )

Allows you to delete all items stored in the phone book.

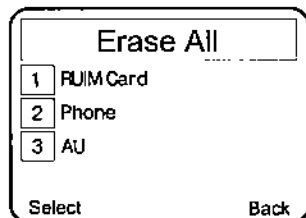
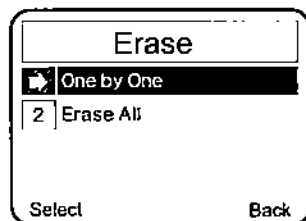
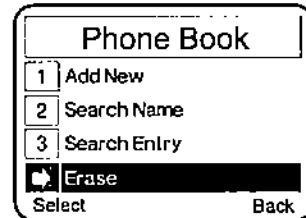
1. Press  **Menu**.
2. Press  **Select**.
3. Press  **Erase**.
4. Highlight the desired sub-menu.
 - ▶ One by one
 - ▶ Erase all





Scroll to select the options and then press  **Select**.

3-3 Messages(Menu)

Write Messages(Menu)

You can write and send messages.

1. Enter the phone number and
Press  **OK** or press  **Find**
the desired number.
2. Press  **OK**.

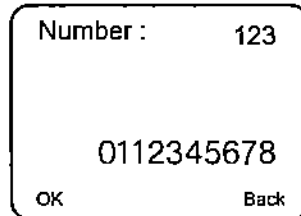
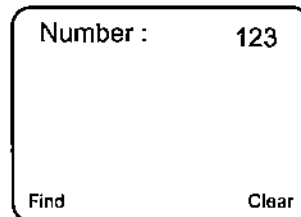
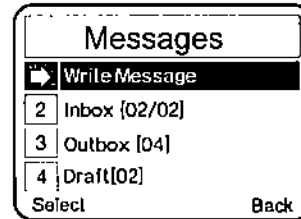

3. Input the message. The number of available characters and the current part number are shown on the top left of the display.

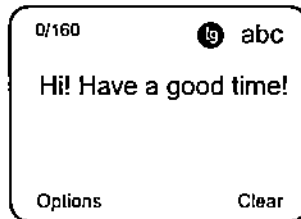

4. When the message is completed, Press **Options** and select from following options :

- ▶ **Send** : To send the message
- ▶ **Save Message** : To save message
- ▶ **Edit Number** : To edit number
- ▶ **Call Back** : To change callback number.

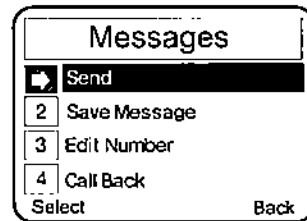

- ▶ **Templates** : You can view or edit the preset messages ('templates') that can be used for writing a message.

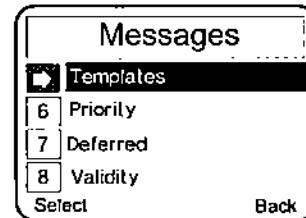

- ▶ **Priority** : Urgent / Normal
- ▶ **Deferred** : Allows you to delay sending the message until the programmed time frame. Delaying time frame is as follows : Immediate, After 30 minutes, After 1 hour, After 2 hours, After 12 hours, After 2 day, After 2 days
- ▶ **Validity** : Indicates the validity of message delivery to the Short Message Center(SMC) without being transmitted to the sending address for certain periods of time. Those messages will be deleted within the programmed time frame. Validity time frames are as follows : Default, After 30 Minutes, After 1 Hour, After 2 Hours, After 12 Hours, After 1 day, After 2 days.

Then press **Select**.

Inbox(Reading a Text Message) (Menu  )

You can read a Text Message.

1. Use scroll key to browse the message you want to read.

Press  **Select Key**

※ **Inbox [X/Y]**

X : The number of messages you have unread.

Y : Total received messages.

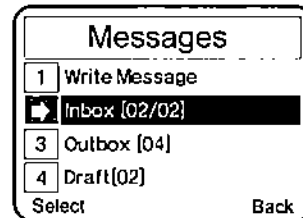

2. While reading the message, you can press 

Options :Key for the following

Reply :To reply the message you have received

Erase :To erase the message



Forward :To send the same message to other person

Save : To save the received message in draft menu

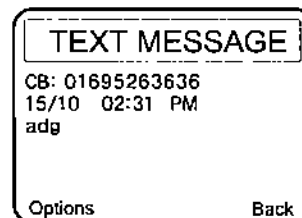
Save Address : To save the received phone number



Outbox(Viewing a message you have sent)

(Menu  )

You can view a message you have sent.

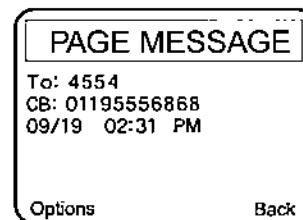
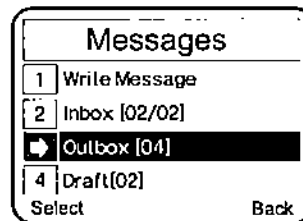

1. Scroll the desired outbox list.

Press  Select.



2. Press Options for the following :

- ▶ **Resend** : To send the same message
- ▶ **Edit Number** : To edit the phone number
- ▶ **Erase** : To erase the message
- ▶ **Save** : To save the sent message in draft menu

Draft(Menu  )

Storage for Inbox and Outbox messages.

1. Scroll to select desired draft list.

Press  **Select**.

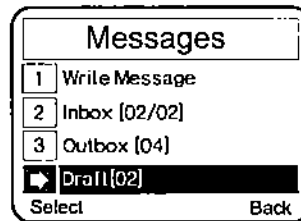

2. Press  **Select** to view the draft list.

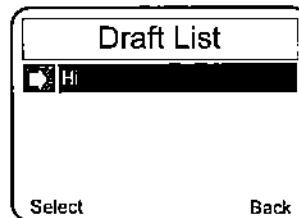

3. Scroll to highlight desired number or name and press  **Select**.

※ You will see several different types of sub-menu title depends on number or name you select.

4. Press  Options for the following:



Reply, Erase, Forward, Save Address.

▶ Draft Outbox Options :
Resend, Edit Number, Erase

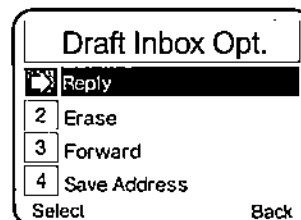
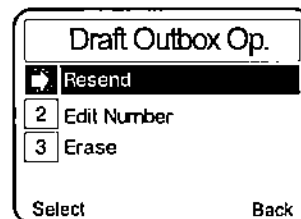
▶ Draft Inbox Options :
Reply, Erase
Forward, Save Address



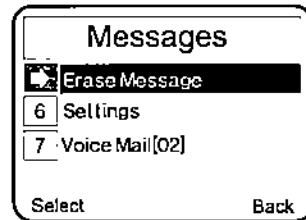

Erase Message(Menu)

1. In the standby mode,
press  **Menu**.
2. Scroll and press **Select**
for **Messages** menu.
3. Highlight **Erase Message**
and press  **Select**.

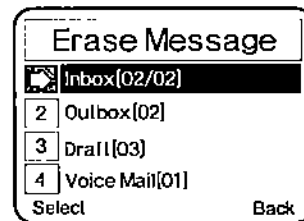

4. You can highlight the
following : Inbox, Outbox,
Draft, Voice mail and
Erase all. and press  **Select**.



5. Press  **Select** to erase
One by One, Erase All.

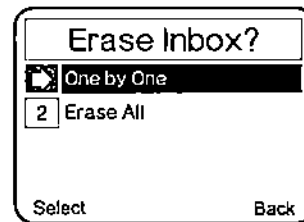

Settings(Menu)

Message Alert(Menu)

You can select the Message alert type

1.Highlight  Message alert.

2.Press  Select.

3.Highlight the desired options.

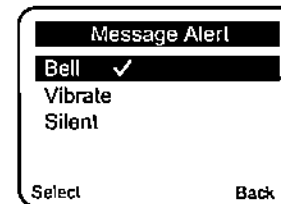
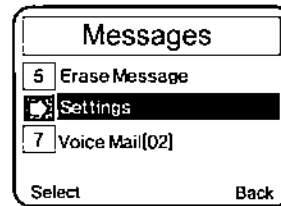



Set Reminder(Menu)

It alerts you unread messages every 2 minutes.

1.Highlight  Set Reminder.

2.Press  Select.

3.Highlight the desired options using  and press  Select.

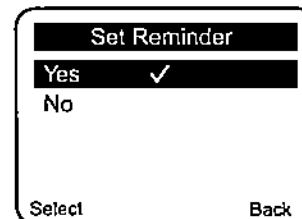



Notification(Menu)

It alerts you when message arrives.

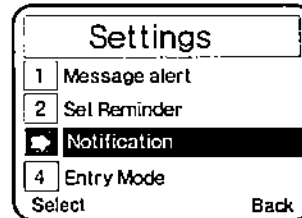
- 1.Highlight  Notification.
- 2.Press  **Select**.



- 3.Highlight the desired options using  and press  **Select**.

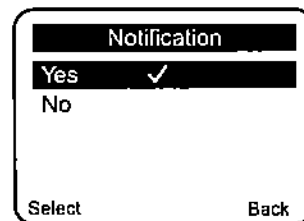

Entry Mode(Menu)

To set default t9 Mode or Alpha Mode when writing a message.

- 1.Highlight  **Entry Mode** and press  **Select**.

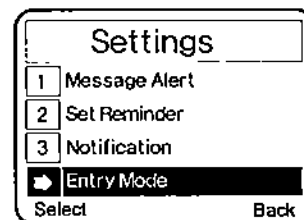

2. Highlight the following options :

- ▶ T9 Mode
 - ▶ Alpha Mode
- Then press  **Select**.

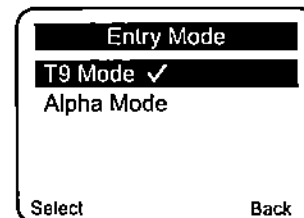

Save Mode(Menu)

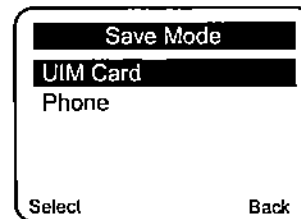
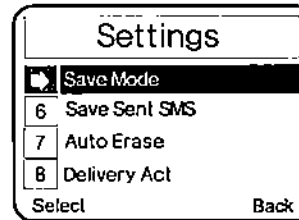

Select whether the names and phone numbers are saved in phone or RUIM card.

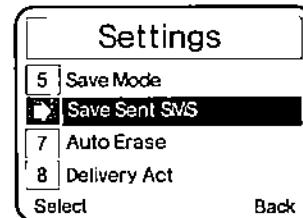

Save Sent SMS(Menu)

1.Highlight  Save Sent SMS to save the messages you sent.



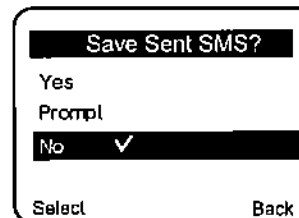

2. Press  Select.
3. Highlight the desired mode.
4. Press  Select.



Auto Erase (Menu)

To erase the Inbox and Outbox.

1. Highlight  **Auto erase** and press  Select.

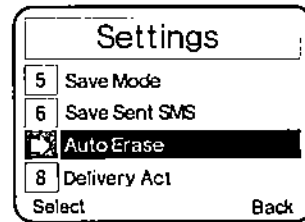

2. Highlight the following options :

- ▶ **Inbox** : *Disables* or *Old Inbox*
- ▶ **Outbox** : *Disables* or *Old Outbox*
- ※ **Old Inbox/Outbox Function** :

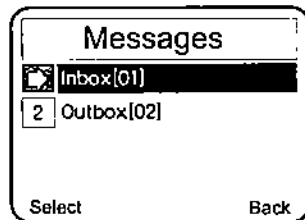



Old message will automatically erase when memory is full.

Delivery Ack (Menu)

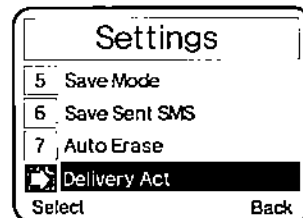

Set to show you the message has been sent or not.

1. Highlight  Delivery ack.
2. Press  Select.



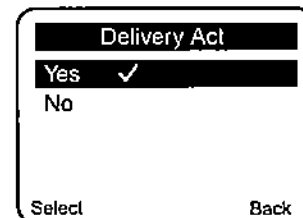

3. Highlight the desired options and press  Select.



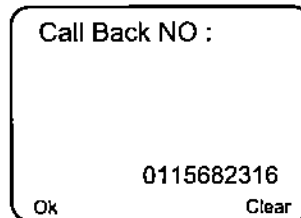
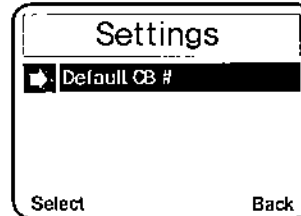

Default CB # (Menu   )

This is an call back number when you send out the messages.

**Voice Mail** (Menu  )

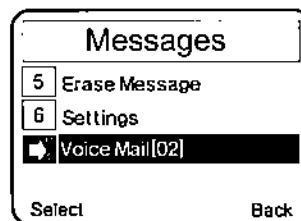
Allows you to view the new voice messages recorded in the voice mail box. When you have a new voice message, your phone will alert you.

**Checking your Voice Mail box**

1. Press  Key or enter the number that designated by your local service provider and listen to new voice message.
to listen to new voice message.

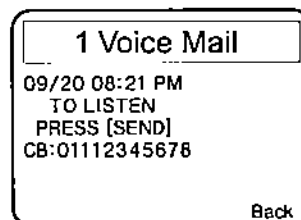



3-4 Call History(Menu)

Missed Calls(Menu)

You can view up to 10 registered phone numbers from which somebody has tried to call you with no success. You can also store and erase the numbers in this menu.

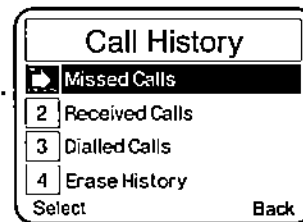
1. Press  **Menu** and scroll down to select **Call History**.



2. Highlight the **Missed Calls** and press  **Select** to view the list of missed calls.

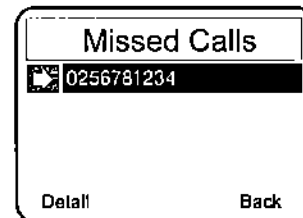

3. Scroll the desired number and press  **Detail** to view the detail information of the missed call.

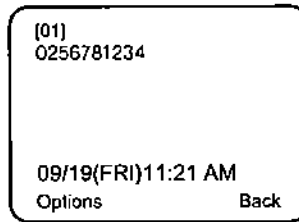

4. Press  **Options** for following options :
Store , Erase

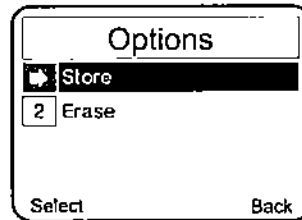

Received Calls (Menu)

You can view up to 10 registered phone numbers from which you have answered a call. You can also store and erase the numbers in this menu.

1. Press  **Menu** and scroll down to select **Call History**.

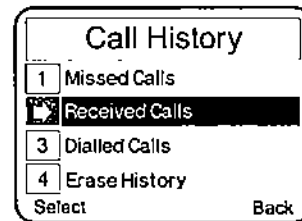

2. Highlight the **Received Calls** and press  **Select** to view the list.



3. Scroll the desired number and press  **Detail** to view the detail information of the received call.

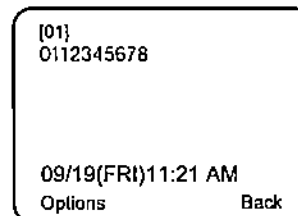

4. Press  **Option** for following options :
Store , Erase

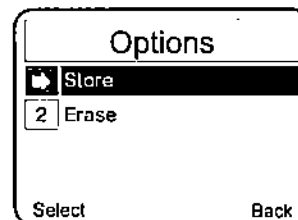

Dialled Calls(Menu **3^{ou}** **3^{ou}**)

You can view up to 10 phone numbers you have called or attempted to call. You can also store and erase the numbers in this menu.

1. Press **Menu** and scroll down to select **Call History**.

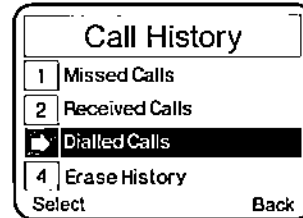

2. Highlight the **Dialled Calls** and press **Select** to view the list.

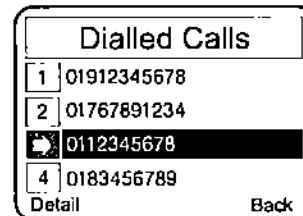

3. Scroll the desired number and press **Detail** to view the detail information of the dialled call.

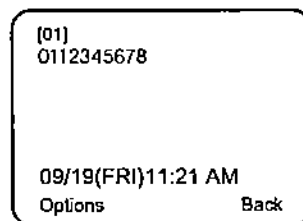

4. Press **Options** for the following :
Store , Erase

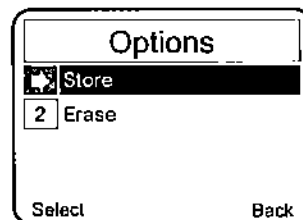

Erase History (Menu ³ ⁴)

You can erase the following history.

1. Press **Menu** and scroll down to select **Call History**.

2. Highlight the **Erase History** and press **Select**.

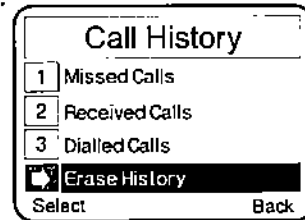

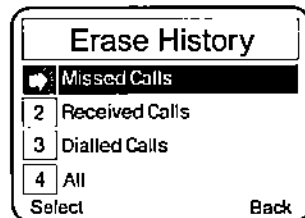

3. Highlight one of the following history and press **Select** :
Missed Calls, Received Calls, Dialed Calls and All



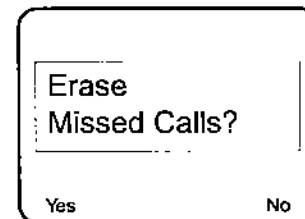

4. Press **Yes** or **No**.



Call Duration(Menu  )

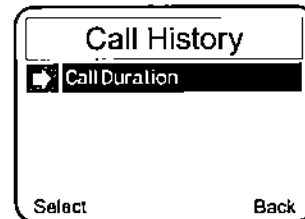

Show the approximate duration of your outgoing and incoming calls.

1. Press  **Menu** and scroll down to select **Call History**.
2. Highlight the **Call Duration** and press  **Select**.

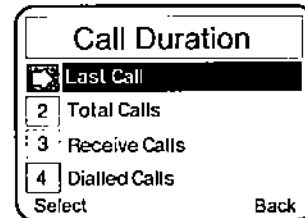

3. You can see the following option :
Home Calls, Roam Calls, Lifetime, Receive Calls and Dialed Calls



4. Highlight the desired duration and Press  **Clear/Done** or  **Back**.

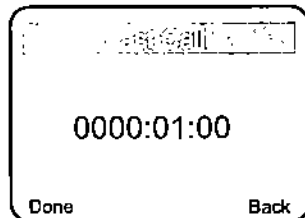

3-5 Sound (Menu)

Ring Type (Menu)

To select a Ring Type.

1. Press  **Menu** and scroll down to select **Sound**.



2. Highlight **Ring Type** and press  **Select**.

3. Select one of five ring types: Bell, Slide Bell, Vibrate, Silent and Bell after Vib with scroll key.

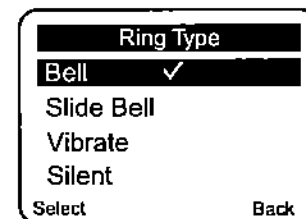

- ▶ **Bell**
- ▶ **Slide Bell**
- ▶ **Vibrate**
- ▶ **Silent**
- ▶ **Bell after vib**

4. Then press  **Select**.

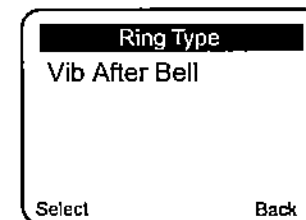

Ring Tones (Menu)

To select a Ring Tone.

1. Press  **Menu** and scroll down to select **Sound**.

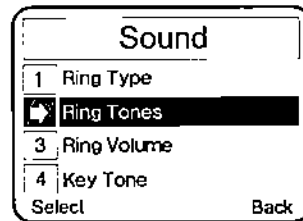

2. Highlight **Ring Tones** and press  **Select**.

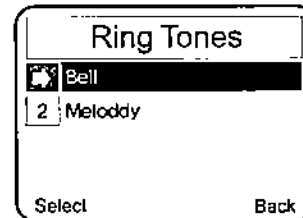

3. Highlight the following options.

- ▶ **Bell** : 10 bells
- ▶ **Melody** : 10 melodies

4. Press  until you find the sound you desire.

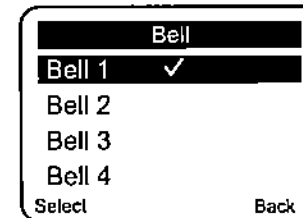



5. Then press  **Select** to save the ring tone.

Ring Volume (Menu)

To select a Ring Volume.

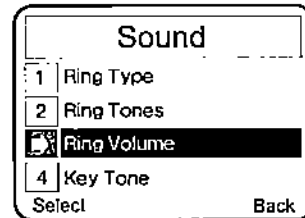
1. Press  **Menu** and scroll down to select **Sound**.



2. Highlight **Ring Volume** and press  **Select**.

3. Adjust the ring volume or with 

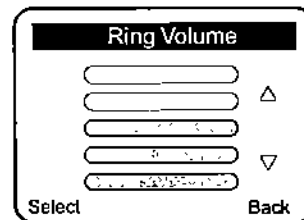



4. Then press  **Select** to save the ring volume.

Key Tone (Menu)

To select Key Tone length and volume.

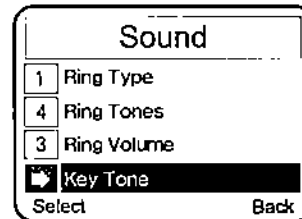
1. Press  **Menu** and scroll down to select **Sound**.



2. Highlight Key Tone and press  **Select**.

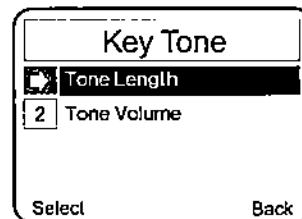

3. Scroll to select the following :

- ▶ **Tone Length**
 - Long DTMF
 - Short DTMF

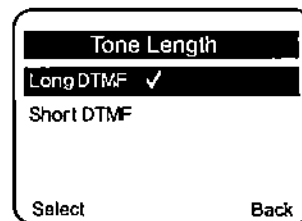

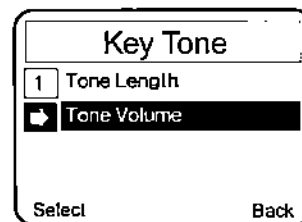

- ▶ **Tone Volume**
Adjust the volume.

Using 



Settings(Menu)

Any of the six Alert options could be turned on or off.

1. Press  **Menu** and scroll down to select **Sound**.
2. Highlight **Settings** and press  **Select**.

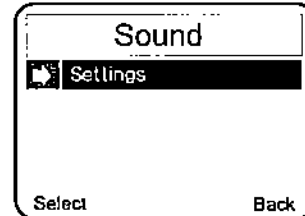

► Check each option and turn it off if not desired.

1) Minute Alert

When your phone is in use sets an alert to inform every minute.

2) Roam Alert

Alert tone notifies the user the call is in roaming system.

3) Fade Alert

Sets an alert to inform you when you have lost a call or services.

4) Low Sig Alert

Alert tone notifies the user when the signal is low.



5) Connect Alert

Alert tone notifies the user when the call is connected.

6) Release Alert

Alert tone notifies the user when the call is disconnected.

3. Choose among the options and press  **Select**.

4. Set **Off/On** with  and then press  **Select**.

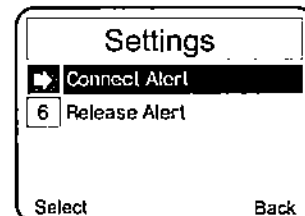
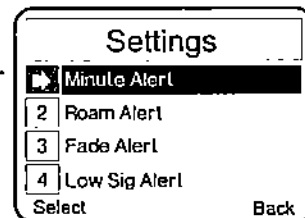

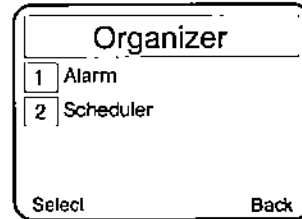

3-6 Organizer (Menu)

Organizer keeps your agenda convenient and easy to access. Simply store your appointments and your phone alerts you with a reminder of your appointment.





Alarm (Menu)

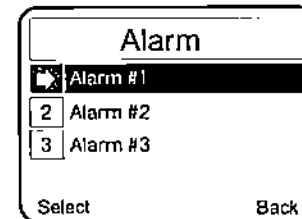
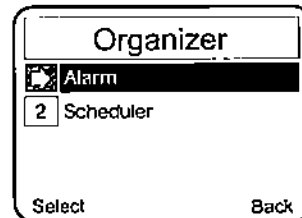

You can set the alarm at the desired time in three options.

1. Press  **Menu** and scroll down to select **Organizer**.
2. Highlight **Alarm** and press  **Select**.
3. Scroll to highlight desired option and press  **Select**.

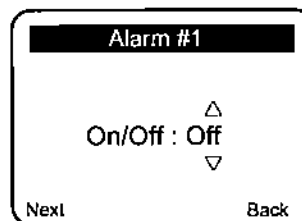

4. On enable screen, choose **Off, Daily and Once** by using  and press  **Next**.



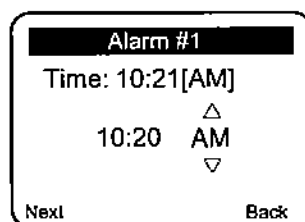

5. On time screen, enter the desired time and select AM/PM using  press  **Next** to go to next step. If you do not want to change the press  **Next** to move to AM/PM.



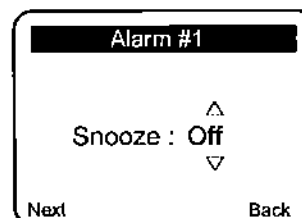





6. On snooze screen, scroll to select the following options : **ON** or **OFF** and press  **Next**.



Scheduler(Menu)

1. Press  **Menu** and scroll down to select **Organizer**.
2. Highlight **Scheduler** and press  **Select**.
3. Scroll to highlight and press  **Select** for the following option.

▶ *Add New*

- ① Enter the date and time 
(to change AM/PM use  and press  **Next**).
- ② Enter the desire schedule and press  **Next**.
- ③ Enter the schedule type by using  and press  **Next**.

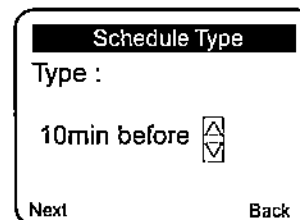
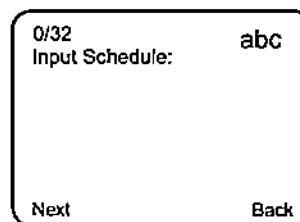
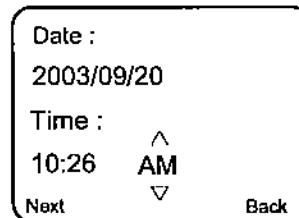
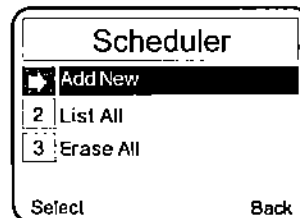
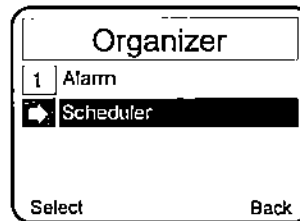

► **List All**

- ① Press  **Select** to view the schedule list

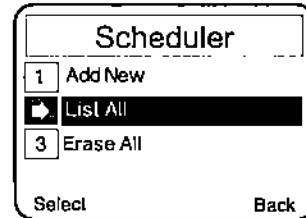

- ② Highlight the one that you want to view in detail.
- ③ To *Edit* or *Erase* the Info press  **Menu**.

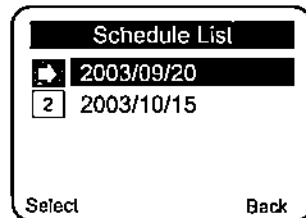

► **Erase All**

Highlight to erase all schedule.

3-7 Security (Menu)

Enter your last four digit phone number or 0000 (depends on local service provider) on Security Menu.

※ When security features, which restrict calls, are in use (Outgoing), call may be possible to certain numbers in some networks (e.g. 112 or other official emergency number).

Restrict (Menu)

1. Press  **Menu** and scroll down to select **security**.

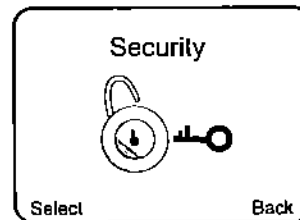

2. Enter Password either emergency last four digit phone number or 0000.

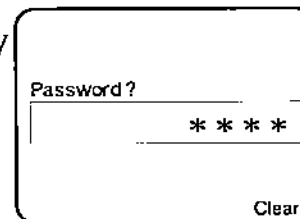



3. Highlight **Restrict** and press  **Select**.

► Check each option and highlight the following options

: **Allow or Restrict**

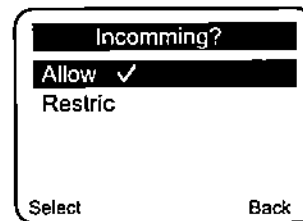
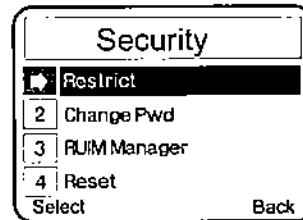

- 1) Receiving
- 2) Dialling
- 3) International
- 4) Speed Dial



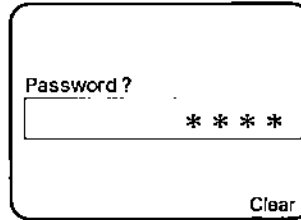

Change Pwd (Menu  )



You can change the default password by entering the new password.

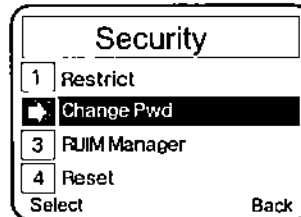
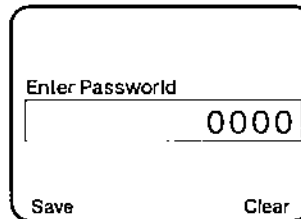



1. Press  **Menu** and scroll down to select **Security**.
2. Enter the secret password.
3. Highlight **Change Pwd** and press  **Select**.
4. Enter new secret password and press  **Save**.

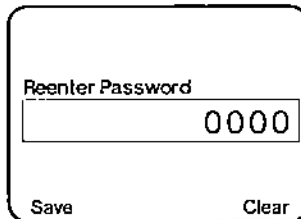



5. Reenter new secret password and press  **Save**.

RUIM Manager (Menu  )

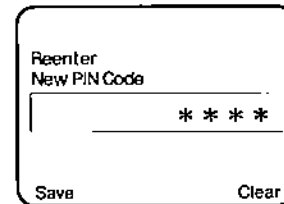
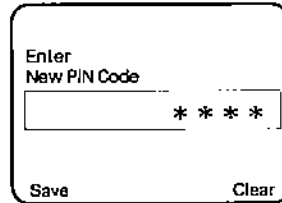
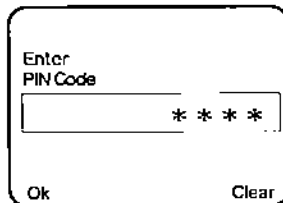
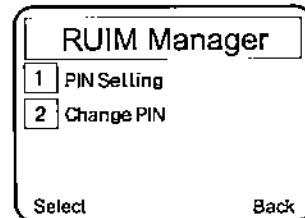
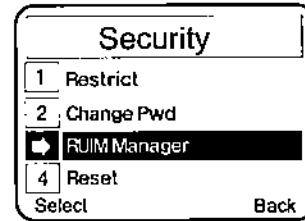

Set your phone to ask for the PIN code of the RUIM card when the phone is switched on. The PIN (Personal Identification Number) code protects your RUIM card against unauthorized use. The PIN code is usually supplied with the RUIM card.

1. Press  **Menu** and scroll down to select **Security**.
2. Enter password either last four digit phone number or 0000.
3. Highlight **RUIM Manager** and press  **Select** for the following options.
 - ▶ PIN Setting : Disable or Enable
 - ▶ Change PIN :





Reset (Menu)

You can reset the menu settings to their original values.

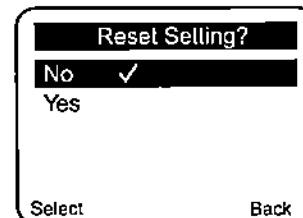
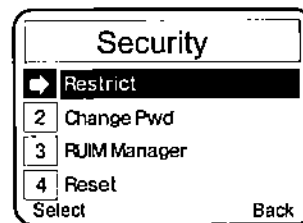
1. Press  **Menu** and scroll down to select **security**.
2. Enter password either last four digit phone number or 0000.
3. Highlight **Reset** and press  **Select**.
4. Highlight the following options : **No** or **Yes**



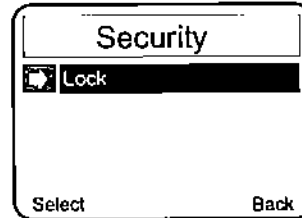

Lock(Menu  )

Keeps your phone from unauthorized use. Once the phone is locked, it is in restricted mode, until the lock password is entered. This will allow you to receive phone calls and still make emergency calls. The lock password is commonly the last 4 digits of your phone.



If you need to modify the lock password, you may modify it using the new lock password within the Security menu.

1. Press  **Menu** and scroll down to select **Settings**.
2. Highlight **Key Lock** and press  **Select**.
3. Select an option and press  **Select**.

- ▶ **Off** : Turn off the key lock mode
- ▶ **On** : Turn on the key lock mode.
- ▶ **On Power-Up** means the phone is locked when it is turned on.

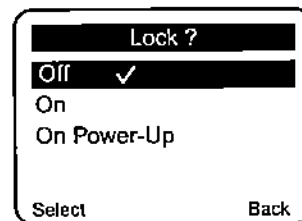



3-8 Settings (Menu)

In this menu you can adjust various settings of the phone.

Call (Menu)

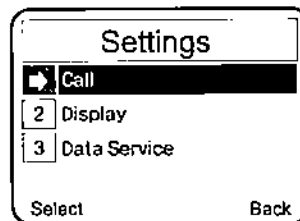
1. Press  **Menu** and scroll down to select **Settings**.



2. Highlight the **Call** and press  **Select**.

Select from following options :





Auto Redial : If you fail to make a call, phone can automatically redial with this function.

Retry Time : You can select **Off** or select **3 Seconds**, **5 Seconds**, **7 Seconds** or **10 Seconds**

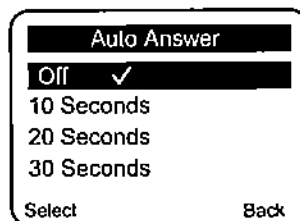
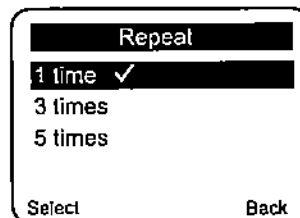
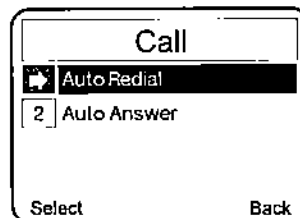
Repeat : You can select **1 time**, **3 times**, **5 times**

Auto Answer : Select from **Off**, **10 Seconds**, **20 Seconds** and **30 Seconds**.





Display(Menu  )**Standby Set** (Menu   )

Select the idle screen in the options.

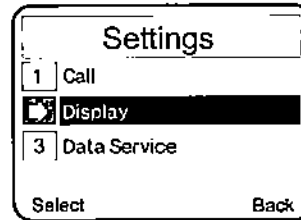
1. Press  **Menu** and scroll down to select **Settings**.



2. Highlight **Display** and press  **Select**.

3. Choose an option and press  **Select**.

- ▶ **Default**
- ▶ **Banner**
- ▶ **Wall Paper**

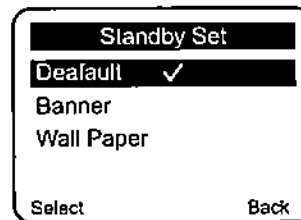

LCD Backlight(Menu)

1. Press  **Menu** and scroll down to select **Settings**.

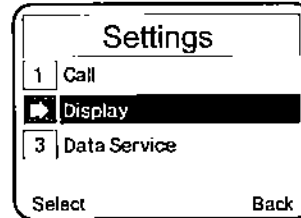

2. Highlight Display and press  **Select**.

3. Scroll to highlight **LCD Backlight** and press  **Select**.

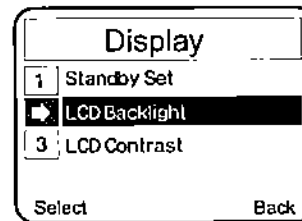

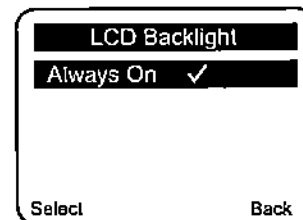
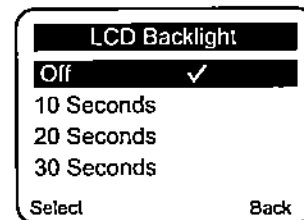

4. Choose an option and press  **Select**.

- ▶ Off
- ▶ 10 Seconds
- ▶ 20 Seconds
- ▶ 30 Seconds
- ▶ Always On



LCD Contrast(Menu)

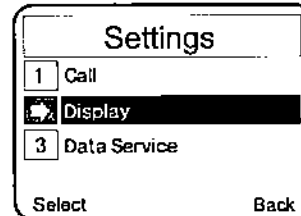

This menu controls the LCD Contrast.

1. Press  **Menu** and scroll down to select **Settings**.
2. Highlight **Display** and press  **Select**.

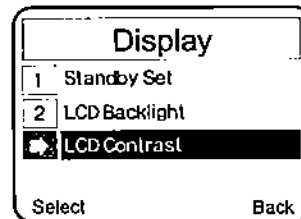

3. Scroll to highlight **LCD Contrast** and press  **Select**.



4. Adjust the contrast using the  and press  **Select**.

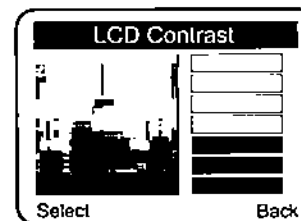



Data Service (Menu)

In Data/Fax setting, you can use your phone to receive data and faxes.

Received Mode (Menu)

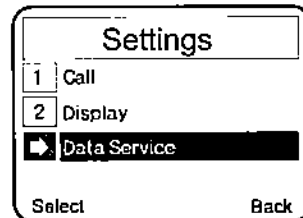
1. Press  **Menu** and scroll down to select **Settings**.



2. Highlight **Data Service** and press  **Select**.

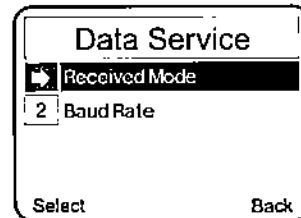

3. Highlight **Received Mode** and press  **Select**.

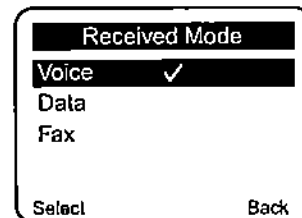

▶ Select from following options.

Voice, Data and Fax





Baud Rate(Menu   )

This setting enables the subscriber terminal to set the data baud.

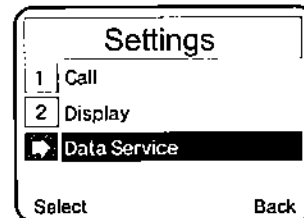
1. Press  **Menu** and scroll down to select **Settings**.
2. Highlight **Data Service** and press  **Select**.



3. Highlight **Baud Rate** and press  **Select**.
Using  select one of the following rate.

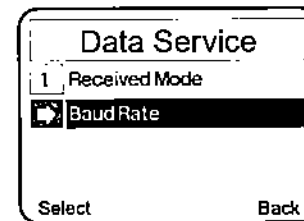

- ▶ 230400 bps
- ▶ 115200 bps
- ▶ 19200 bps

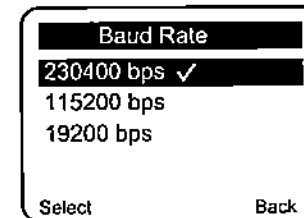
**3-9 Game Pon Man Adventure**



Chapter 4.
Safety Guidelines

ALCOMM

4-1 Safety Information

Traffic Safety

Do not use the phone hand held while driving a vehicle. Always secure the phone in its holder; do not place the phone on the passenger seat or where it can break loose in a collision or sudden stop. Remember road safety always comes first!

Operating Environment

Remember to follow any special regulations in force in any area and always switch off your phone whenever it is forbidden to use it, or when it may cause interference or danger.

Use the phone only in its normal operating positions.

Parts of the phone are magnetic. Metallic materials may be attracted to the phone, and persons with a hearing aid should not hold the phone to the ear with the hearing aid. Do not place credit cards or other magnetic storage media near the phone, because information stored on them may be erased.

Electronic Devices

Most modern electronic equipment is shielded from radio frequency(RF) signals. However, certain electronic equipment may not be shielded against the RF signals from your wireless phone.

Pacemakers

Pacemaker manufacturers recommend that a minimum separation of 20cm(6 inches) be maintained between a handheld wireless phone and a pacemaker to avoid potential interference with the pacemaker. These recommendations are consistent with the independent research by and recommendations of Wireless Technology Research.

Persons with pacemakers:

- Should always keep the phone more than 20cm (6 inches) from their pacemaker when the phone is switched on;
- Should not carry the phone in a breast pocket;
- Should use the ear opposite the pacemaker to minimize the potential for interference.
- If you have any reason to suspect that interference is taking place, switch off your phone immediately.

Hearing Aids

Some digital wireless phones may interfere with some hearing aids. In the event of such interference, you may want to consult your service provider.

Other Medical Devices

Operation of any radio transmitting equipment, including cellular phones, may interfere with the functionality of inadequately protected medical devices. Consult a physician or the manufacturer of the medical device to determine if they are adequately shielded from external RF energy or if you have any questions. Switch off your phone in health care facilities when any regulations posted in these areas instruct you to do so. Hospitals or health care facilities may be using equipment that could be sensitive to external RF energy.

Vehicles

RF signals may affect improperly installed or inadequately shielded electronic systems in motor vehicles(e.g. electronic fuel injection systems, electronic anti-skid(anti-lock) braking systems, electronic speed control systems, air bag systems). Check with the manufacturer or its representative regarding your vehicle. You should also consult the manufacturer of any equipment that has been added to your vehicle.

Posted facilities

Switch your phone off in any facility where posted notices require so.

Potentially Explosive Atmospheres

Switch off your phone when in any area with a potentially explosive atmosphere and obey all signs and instructions. Sparks in such areas could cause an explosion or fire resulting in bodily injury or even death.

Users are advised to switch off the phone when at a refueling point(service station).

Users are reminded of the need to observe restrictions on the use of radio equipment in fuel depots(fuel storage and distribution areas), chemical plants or where blasting operations are in progress.

Areas with a potentially explosive atmosphere are often but not always clearly marked. They include below deck on boats; chemical transfer or storage facilities; vehicles using liquefied petroleum gas(such as propane or butane); areas where the air contains chemicals or particles, such as grain, dust or metal powders; and any other area where you would normally be advised to turn off your vehicle engine.

Safety Information

1 . SAFETY INFORMATION FOR FIXED WIRELESS TERMINALS

.POTENTIALLY EXPLOSIVE ATMOSPHERES

Turn your phone OFF when in any area with a potentially explosive atmosphere and obey all signs and instructions. Sparks in such areas could cause an explosion or fire resulting in bodily injury or even death.

INTERFERENCE TO MEDICAL DEVICES

Certain electronic equipment may be shielded against RF signal from your wireless phone. (pacemakers, Hearing Aids, and so on) Turn your phone OFF in health care facilities when any regulations posted in these areas instruct you to do so.

RF signals may affect improperly installed or inadequately shielded electronic system in motor vehicles.

.EXPOSURE TO RF ENERGY

Use only the supplied or an approved replacement antenna.

Do not touch the antenna unnecessarily when the phone is in use.

Do not move the antenna close to, or touching any exposed part of the body when making a call.

FCC Compliance Information

This device complies with Part 15 of FCC Rules.

Operation is subject to the following two conditions:

- (1) This device may not cause harmful interference, and
- (2) This device must accept any interference received.
Including interference that may cause undesired operation.

Information to User

This equipment has been tested and found to comply with the limits for a Class B digital device, pursuant to part 15 of the FCC Rules. These limits are designed to provide reasonable protection against harmful interference in a residential installation. This equipment generates, uses and can radiate radio frequency energy and, if not installed and used in accordance with the instructions, may cause harmful interference to radio communications. However, there is no guarantee that interference will not occur in a particular installation. If this equipment does cause harmful interference to radio or television reception, which can be determined by turning the equipment off and on, the user is encouraged to try to correct the interference by one or more of the following measures:

- Reorient or relocate the receiving antenna.
- Increase the separation between the equipment and receiver.
- Connect the equipment into an outlet on a circuit different from that to which the receiver is connected.
- Consult the dealer or an experienced radio/ tv technician for help.

SAFETY INFORMATION FOR RF EXPOSURE

Body worn operation

This device was tested for typical body-worn operations with the back of the phone kept 25 mm. from the body. To maintain compliance with FCC RF exposure requirements, use only belt-clips, holsters or similar accessories that maintain a 25 mm. separation distance between the user's body and the back of the phone, including the antenna. The use of belt-clips, holsters and similar accessories should not contain metallic components in its assembly. The use of accessories that do not satisfy these requirements may not comply with FCC RF exposure requirements, and should be avoided.

SAR INFORMATION

THIS MODEL PHONE MEETS THE GOVERNMENT'S
REQUIREMENTS FOR EXPOSURE TO RADIO WAVES.

Your wireless phone is a radio transmitter and receiver. It is designed and manufactured not to exceed the emission limits for exposure to radiofrequency (RF) energy set by the Federal Communications Commission of the U.S. Government. These limits are part of comprehensive guidelines and establish permitted levels of RF energy for the general population. The guidelines are based on standards that were developed by independent scientific organizations through periodic and thorough evaluation of scientific studies. The standards include a substantial safety margin designed to assure the safety of all persons, regardless of age and health. The exposure standard for wireless mobile phones employs a unit of measurement known as the Specific Absorption Rate, or SAR. The SAR limit set by the FCC is 1.6 W/kg. * Tests for SAR are conducted with the phone transmitting at its highest certified power level in all tested frequency bands. Although the SAR is determined at the highest certified power level, the actual SAR level of the phone while operating can be well below the maximum value. This is because the phone is designed to operate at multiple power levels so as to use only the power required to reach the network. In general, the closer you are to a wireless base station antenna, the lower the power output. Before a phone model is available for sale to the public, it must be tested and certified to the FCC that it does not exceed the limit established by the government adopted requirement for safe exposure. The tests are performed in positions and locations (e.g., at the ear and worn on the body) as required by the FCC for each model. The highest SAR value for this model phone when tested for use at the ear is **1.30W/Kg** and when worn on the body, as described in this user guide, is **0.338W/Kg**. (Body-worn measurements differ among phone models, depending upon available accessories and FCC requirements). While there may be differences between the SAR levels of various phones and at various positions, they all meet the government requirement for safe exposure. The FCC has granted an Equipment Authorization for this model phone with all reported SAR levels evaluated as in compliance with the FCC RF exposure guidelines. SAR information on this model phone is on file with the FCC and can be found under the Display Grant section of <http://www.fcc.gov/oet/fccid> after searching on **FCC ID: RURACH-700**.

Additional information on Specific Absorption Rates (SAR) can be found on the Cellular Telecommunications Industry Association (CTIA) web-site at <http://www.wow-com.com>.

* In the United States and Canada, the SAR limit for mobile phones used by the public is 1.6 watts/kg (W/kg) averaged over one gram of tissue. The standard incorporates a substantial margin of safety to give additional protection for the public and to account for any variations in measurements.

U.S.A.

U.S.FEDERAL COMMUNICATIONS COMMISSION

RADIO FREQUENCY INTERFERENCE STATEMENT

INFORMATION TO THE USER

NOTE : This equipment has been tested and found to comply with the limits for a Class B digital device pursuant to Part 15 of the FCC Rules.

These limits are designed to provide reasonable protection against harmful Interference in a residential installation This equipment generates, uses, and can radiate radio frequency energy and, if Not installed and used in accordance with the instructions, may cause harmful Interference to radio communications. However, there is no guarantee that interference will not occur in a particular Installation. If this equipment does cause harmful interference to radio or television reception, which can be determined by turning the equipment off and on, the user is encouraged to try to correct the interference by one or more of the following measures:

- Reorient or relocate the receiving antenna.
- Increase the separation between the equipment and receiver.
- Connect the equipment into an outlet of a circuit different from that to which the receiver is connected.
- Consult the dealer or an experienced radio/TV technician for assistance.

Changes or modification not expressly approved by the party responsible for Compliance could void the user' s authority to operate the equipment. Connecting of peripherals requires the use of grounded shielded signal cables.