

User's manual

SYSTEM OVERVIEW

It is equipment which operates the entertainment functions of the car from the backseat.
e.g. air-conditioner, Navigation, Radio, Audio, etc.

OUTLINE

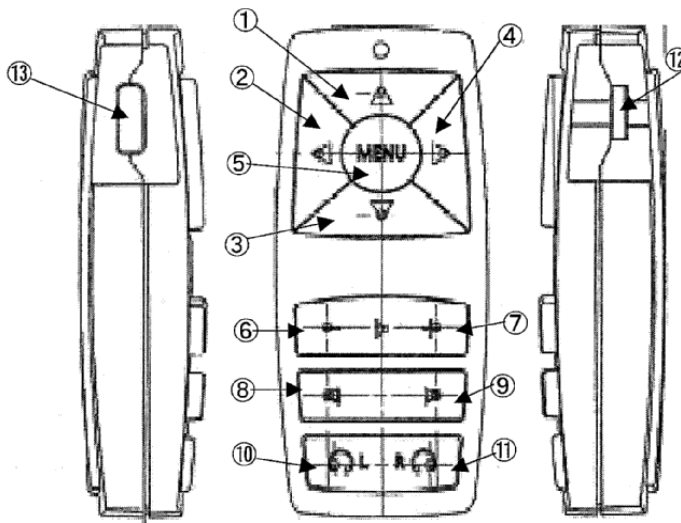

SWITCHE NAME AND FUNCTIONS

No.	SW NAME	FUNCTION
1	UP SW	CALL THE SECOND MENU SCROLL UPWARD THE MAP
2	LEFT SW	CALL THE SECOND MENU SCROLL LEFTWARD THE MAP
3	Down SW	CALL THE SECOND MENU SCROLL DOWNWARD THE MAP
4	Right SW	CALL THE SECOND MENU SCROLL DOWNWARD THE MAP
5	Menu SW	CALL THE MAIN MENU
6	Volume Down SW	VOLUME DOWN
7	Volume Up SW	VOLUME UP
8	Scan Down SW	CHANNEL SELECTION DOWNWARD
9	Scan Up SW	CHANNEL SELECTION UPWARD
10	Side select L SW	SELECT THE LEFT SHEAT
11	Side select R SW	SELECT THE RIGHT SHEAT
12	NAVI UP	SHIFT THE PAGE UPWARD
	NAVI Down	SHIFT THE PAGE DOWNWARD
13	Confirmation SW	CONFIRMATION

NOTICE

- Please avoid use and storage the product in the following place.
(High temperature, humid place, direct sunlight)
- Since there is no waterproof ness, please do not soak in water.
- In the following cases please exchange two batteries for new ones, because the battery may be not enough voltage.
- Slow/no response to the SW operation
- Please scrap the used battery according as the local rule.
- Please do not handle the products roughly.(e.g. throw, swing, etc)
- Please do not disassemble the product. It may break down.

(If the battery is misused, there are some fears of generation of heat, breakage, and a liquid leak. Be careful as follows.)

- Please do not use a rechargeable battery.
- Please set the polarity of a battery correctly.
- Please do not short-circuit, recharge, disassemble and put in into fire.
- When the leak liquid from the battery went into your eye, please wash with a lot of water. Then consult a doctor.
If the leak liquid attached to your skin or clothes, please wash with water.

This device complies with Part 15 of FCC Rules and RSS-Gen of IC Rules.
Operation is subject to the following two conditions: (1) this device may not cause interference, and (2) this device must accept any interference, including interference that may cause undesired operation of this device.

FCC WARNING

Changes or modifications not expressly approved by the party responsible for compliance could void the user's authority to operate the equipment.