



AMPAK

AP6XXX

Evaluation Kits

User manual

Version 1.2

Revision History

Date	Revision Content	Revised By	Version
2012/12/26	Initial released	Dora	1.0
2013/03/07	Modify figure1	Dora	1.1
2013/06/06	Modify figure1	Dora	1.2

1. AP6XXX Evaluation Board Introduction

AP6XXX Evaluation board (EVB) likes as figure1. That is designed for IEEE802.11 a/b/g/n/ac WLAN with integrated Bluetooth, FM, NFC and GPS application. It is subject to provide a convenient environment for customer’s verification on WiFi or Bluetooth function. There are many controller pins and reserved GPIO on Evaluation board which describes as below.

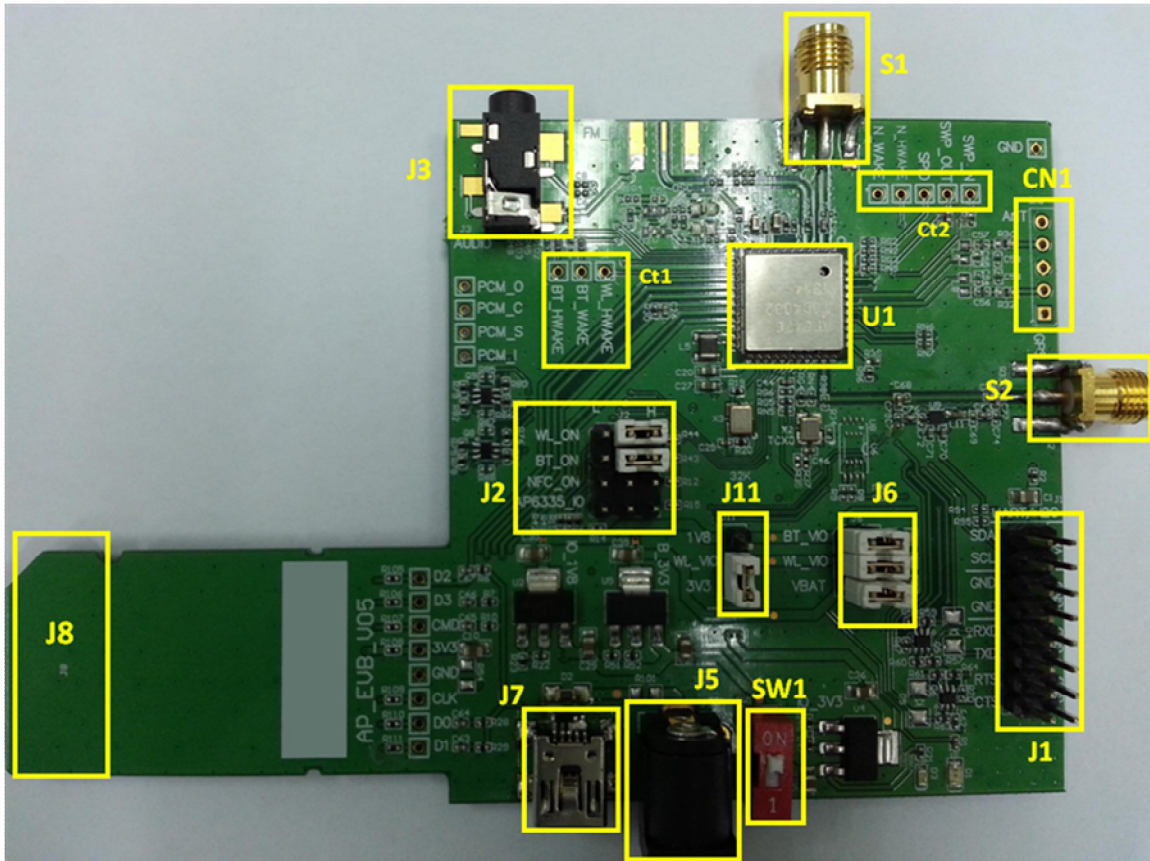

Figure1. Top view of AP6XXX EVB

Interface highlights:

1. U1: AP6XXX SIP module.
2. J1: UART interface connects with UART transport board for BT and GPS measuring, it also provides I2C (SDA/SCL) for NFC measuring.
3. J2: Enable(H) or disable(L) Bluetooth, WiFi, NFC function and AP6335_SDIO I/O voltage selection.(H for SDIO 3.3V, L for SDIO 1.8V)
4. J3: FM audio out interface.
5. J5: 5V DC adaptor input connector.
6. J6: VBAT / WL_VIO / BT_VIO for main system I/O power path.
7. J7: 5V DC mini USB input connector.
8. J8: Standard SDIO interfaces for Wi-Fi performance measured.

9. J11: WL_VIO power path for 1V8 or 3V3 selection.
10. SW1: Power on/off switch.
11. CN1: NFC interface connects with NFC antenna.
12. S1: SMA connector let RF signal in/out path, you could connect with RF cable or Dipole antenna.
13. S2: SMA connector let GPS RF signal input, you could connect with GPS antenna.
14. Ct1: WLAN and BT control pins, strongly recommended WL_HWAKE(IRQ) connected to MCU.
15. Ct2: NFC control pins, strongly recommended N_WAKE and N_H_WAKE connected to MCU.

2. WiFi function verification step

WiFi SDIO: Using external pull up resistors depends on the SDIO supply voltage. For 1.8V, the resistance range is 30KΩ~82KΩ. For 3.3V, its range from 21 KΩ~41 KΩ on the four data lines and the CMD line as the following circuitry.

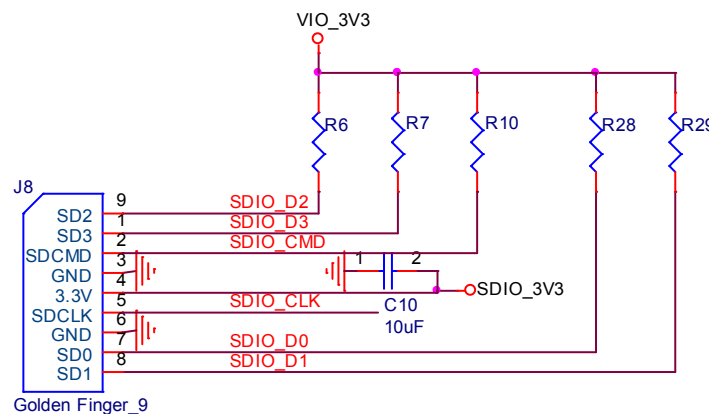

Figure2. WiFi verification connection interface to Host SDIO

Hardware Setup:

- ❖ Refer to Figure2 SDIO pin definition connects the J8 interface of AP6XXX evaluation board to Host SDIO control interface.
- ❖ Using pull high resistors (R6, R7, R10, R28, R29) that resistance is 30Kohm for 1.8V or 3.3V VDDIO pull up voltage. (Pull high resistors are un-necessary if at verification phase.)
- ❖ Connects an external antenna at SMA connector on the evaluation board.
- ❖ Note to the VDDIO voltage level should be the same with GPIO voltage level of Host CPU. (VDDIO 3.3V or 1.8V selection by jump J11)

WiFi software setup:

Please follow up software guideline of Ampak official released.

3. Bluetooth function verification step

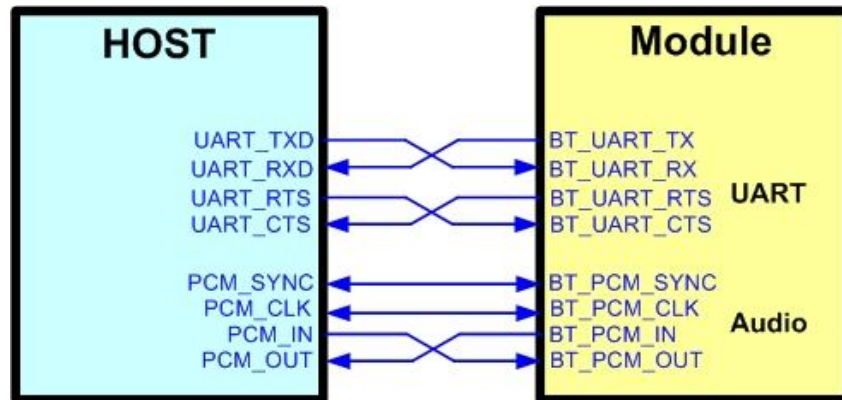

Figure3. Bluetooth verification connection interface to Host UART

Hardware Setup:

- ❖ Refer to Figure3 UART pin definition connects the J1 interface of AP6XXX evaluation board to Host UART control interface.
- ❖ Connects an external antenna at SMA connector on the evaluation board.
- ❖ Note to the VDDIO voltage level should be the same as GPIO voltage level of Host CPU.

WiFi and Bluetooth software setup:

Please follow up software guideline of Ampak official released.



Federal Communications Commission (FCC) Statement

You are cautioned that changes or modifications not expressly approved by the part responsible for compliance could void the user's authority to operate the equipment.

This equipment has been tested and found to comply with the limits for a Class B digital device, pursuant to part 15 of the FCC rules. These limits are designed to provide reasonable protection against harmful interference in a residential installation. This equipment generates, uses and can radiate radio frequency energy and, if not installed and used in accordance with the instructions, may cause harmful interference to radio communications. However, there is no guarantee that interference will not occur in a particular installation. If this equipment does cause harmful interference to radio or television reception, which can be determined by turning the equipment off and on, the user is encouraged to try to correct the interference by one or more of the following measures:

- Reorient or relocate the receiving antenna.
- Increase the separation between the equipment and receiver.
- Connect the equipment into an outlet on a circuit different from that to which the receiver is connected.
- Consult the dealer or an experienced radio/TV technician for help.

This device complies with Part 15 of the FCC Rules. Operation is subject to the following two conditions:

- 1) this device may not cause harmful interference, and
- 2) this device must accept any interference received, including interference that may cause undesired operation of the device.

(WIFI) For product available in the USA/Canada market, only channel 1~11 can be operated. Selection of other channels is not possible.



FCC RF Radiation Exposure Statement :

1. This Transmitter must not be co-located or operating in conjunction with any other antenna or transmitter.

2. This equipment complies with FCC RF radiation exposure limits set forth for an uncontrolled environment. This equipment should be installed and operated with a minimum distance of 20 centimeters between the radiator and your body.

This module has been granted modular approval for mobile applications. OEM integrators for host products may use the module in their final products without additional FCC certification if they meet the following conditions. Otherwise, additional FCC approvals must be obtained.

1. The host product with the module installed must be evaluated for simultaneous transmission requirements.

2. The users manual for the host product must clearly indicate the operating requirements and conditions that must be observed to ensure compliance with current FC RF exposure guidelines.

3. To comply with FCC regulations limiting both maximum RF output power and human exposure to RF radiation, the maximum antenna gain including cable loss in a mobile-only exposure condition must not exceed {Insert Reference to Your Antenna Information Here.

Note: The end product shall has the words “Contains Transmitter Module FCC ID: ZQ6-AP6212A”