

Chromebase Commercial

WT22M-FBG
User Guide



Table of Contents

Disposal Instructions.....	1
Copyright.....	5
Disclaimer.....	5
Energy Star.....	6
1. Safety Instructions.....	7
2. Packing List.....	11
2-1. Standard Accessories.....	11
2-2. Optional Accessories.....	12
3. Product Introduction.....	13
3-1. Outlook View.....	13
3-2. Getting to know your Chromebase Commercial.....	14
3-3. Dimensions.....	20
3-4. Peripheral Installation.....	21
Wall Mount Kit Assembly.....	21
4. Declaration.....	22
5. Contact Information.....	24
6. Chrome Care.....	26



Disposal Instruction (US)

For better protection of our earth, please don't throw this electronic device into municipal trash bin when discarding.

To minimize pollution and ensure utmost protection of the global environment, please recycle the product. For more information about the collection and recycling of Waste Electrical and Electronic Equipment (WEEE), you are invited to visit our homepage at www.aopen.com under "Green Products"

廃棄上の指示

より良い地球保護のために、電子機器を廃棄処分にする時は、ゴミ箱に捨てないで下さい。汚染を最小限に抑え、地球環境の最大限の保護のために、製品をリサイクルして下さい。 廃電気電子機器 (WEEE) の回収とリサイクルについての情報は、弊社ホームページ www.aopen.com の "Green Products" (環境に優しい製品) をご覧下さい。

廢棄及回收處理

為了保護環境，請勿將本產品當作一般廢棄物處理。為減少環境污染，維護地球資源，本產品報廢時，請回收本產品。

有關收集和回收廢棄電子電氣設備 (WEEE) 的更多信息，請參考我們的網頁 www.aopen.com "綠色產品" 的資訊。

Instruktion til bortskaffelse (Danish)

Af hensyn til vores miljø bedes De ikke bortskaffe denne elektroniske enhed i en almindelig affaldsspand. For at mindske forurening og sikre beskyttelse af miljøet bedes De genbruge produktet. For yderligere information vedrørende indsamling og genbrug af elektronik-affald (Waste Electrical and Electronic Equipment (WEEE)) er De velkommen til at besøge vores website www.aopen.com og læse nærmere under "Green Products".

Verwijderingsinstructie (Dutch)

Om mogelijke schade aan het milieu of de menselijke gezondheid door ongecontroleerde afvalverwijdering te voorkomen, moet u dit elektronisch product scheiden van andere soorten afval en op een verantwoorde manier recyclen. Verwijder dit product dan ook alstublieft niet samen met ander huishoudelijk afval. Voor meer informatie over de verzameling en recycling van elektrisch afval en elektronische apparatuur (WEEE), nodigen we u uit om onze homepage te bezoeken www.aopen.com onder "Green Products".

Instruction de Disposition (French)

Pour une meilleure protection de la terre, ne jetez pas ce dispositif électronique dans la poubelle municipale lors de la disposition. Pour éliminer la pollution et assurer la plus grande protection de l'environnement global, réutilisez s'il vous plaît le produit. Pour plus d'informations sur la gestion des déchets d' Equipements Electriques et Electroniques (DEEE ou WEEE), vous êtes invité à visiter notre site à www.aopen.com sous " Green Products".

Entsorgungsanleitung (German)

Zum besseren Schutze unseres Planeten, schmeissen Sie elektrische Geräte bitte nicht in öffentliche Mülleimer. Zur Verringerung der Verschmutzung und zur Sicherstellung grösstmöglichen Schutzes der Umwelt recyceln Sie bitte das Produkt. Für mehr Informationen zum Sammeln und Recyceln von elektrischen und elektronischen Müll (WEEE) besuchen Sie bitte unsere Homepage unter www.aopen.com unter dem Punkt "Green Products".

Istruzioni per lo smaltimento (Italian)

Per una migliore salvaguardia del nostro pianeta, si prega di non gettare questo dispositivo elettronico nei normali rifiuti al momento dell'eliminazione. Per ridurre al minimo l'inquinamento ed assicurare la massima protezione dell'ambiente, si prega di riciclare il prodotto. Per maggiori informazioni riguardanti la raccolta ed il riciclaggio delle apparecchiature elettriche ed elettroniche residue (WEEE), siete invitati a visitare la nostra homepage www.aopen.com alla voce "Green Products".

Instruksjoner for Resirkulering og Oppsamling (Norwegian)

For í beskytte vór planet, kast ikke dette elektroniske utstyret sammen med vanlig avfall. For í beskytte vór natur og miljø, vennligst resirkuler dette produktet. For mer informasjon om oppsamling og resirkulering i henhold til Waste Electrical and Electronic Equipment (WEEE), se vór hjemmeside på www.aopen.com under "Green Products".

REEE - Programa de Tratamento de Resíduos de Equipamentos Eléctricos e Electrónicos (Portugese)

Para melhor protecção ambiental do nosso planeta terra, não coloque o dispositivo electrónico no receptáculo de lixo municipal. Para minimizar a poluição e garantir protecção máxima do ambiente global, recicle o produto. Para mais informações sobre acerca da recolha e reciclagem de Equipamento Eléctrico e Electrónico (WEEE), convidamos-lhe a visitar nossa página na Internet em www.aopen.com sobre "Green Products".

Instrucciones para depositar los productos electrónicos (Spanish)

Para proteger mejor el medio ambiente, por favor, no deposite los productos electrónicos en los contenedores de basura tradicionales. Para reducir la contaminación y proteger el medio ambiente se recomienda que los recicle. Para más información acerca de dónde depositar y cómo reciclar Equipos Electrónicos y Desperdicios Electrónicos (WEEE), por favor, visite la página web www.aopen.com entre en la sección Productos Ecológicos ("Green Products").

Kassering (Swedish)

För att bättre värna om vår jord bör denna elektroniska utrustning ej kasseras tillsammans med vanligt avfall. För att minimera mängden föroreningar och så långt som möjligt skydda den globala miljön bör produkten återvinnas. För vidare information om insamling och återvinning av uttjänta elektriska och elektroniska produkter (Waste Electrical and Electronic Equipment, WEEE), besök avsnittet "Green Products" på vår hemsida, www.aopen.com.

Copyright

Copyright of this publication belongs to AOPEN Inc. AOPEN reserves the right to change the content of this publication without obligation to notify any party of such changes or revisions. No part of this publication may be reproduced, transcribed, transmitted, translated into any language, and stored in a retrieval system in any form or by any means electronically, mechanically, optically without the prior written permission of AOPEN Inc.

Disclaimer

AOPEN makes no warranties or representations, either expressed or implied, with respect to the content herein and specifically disclaims any warranties, merchantability of fitness for any particular purpose.

AOPEN and AOPEN logos used herein are registered trademarks of AOPEN Inc.

All other brand names and trademarks are owned by their respective owners.

Copyright © 2015 by AOPEN Inc.

All rights reserved.

Chrome, Chromebox and Chromebase are

Registered trademarks of Google Inc.

ENERGY STAR Certification



ENERGY STAR is a U.S. Environmental Protection Agency voluntary program that helps businesses and individuals save money and protect our climate through superior energy efficiency. AOPEN product with ENERGY STAR logo complies with the ENERGY STAR standard.

The monitor and computer are automatically set to sleep after 8 and 30 minutes of user inactivity. You can click the mouse or press any key on the keyboard or press touch screen to wake your computer.

Additional information on the potential energy and financial savings of the power management feature can be found on the EPA ENERGY STAR Power Management Web site at <http://www.energystar.gov/powermanagement>.

Additional information on the ENERGY STAR program and its environmental benefits are available on the EPA ENERGY STAR Web site at <http://www.energystar.gov>.

1. Safety Instructions

1. Please read these safety instructions carefully.
 2. Please keep this User's Manual for reference.
 3. Please disconnect this equipment from its power source before cleaning. Don't use liquid or sprayed detergent for cleaning. Use a lightly moistened sheet or cloth for cleaning.
 4. Make sure the equipment is connected to the power source with the correct voltage, frequency and amperage.
 5. All cautions and warnings on the equipment should be noted and followed.
 6. Never pour any liquid into any opening of this equipment; this could cause fire or electrical shock.
 7. Never disassemble the equipment. For safety reasons, the equipment should only be handled by qualified service personnel.
 8. If one of the following situations arises, get the equipment checked by service personnel:
 - a. Liquid has penetrated into the equipment.
 - b. The equipment has been exposed to moisture.
 - c. The equipment has not worked well or you cannot get it to work according to user's manual.
 - d. The equipment has been dropped and damaged.
 - e. The equipment has obvious signs of breakage.
 9. Caution on use of battery: Use the battery recommended by the manufacturer or the same type of battery installed by the manufacturer. If the incorrect battery is used, it may cause an explosion or can present a fire hazard. Recycle or discard used batteries according the manufacturer's instruction or your local authority.
-  **ATTENTION! Danger d'explosion**
lorsque la batterie est remplacée de
façon incorrecte.
10. Ambient operating temperature for this equipment is: 0~ 40 degrees Celsius. (32~104 degrees Fahrenheit)
 11. Wall Mounting Holder needs to be an UL 1678 approved product.

Risk of Overheating!

- a. Do not install Chromebase Commercial in an enclosed space.
- b. Be sure the heat sink that is on the top side of the Chromebase Commercial has at least 2 cm of clear space for thermal holes.
- c. Do not place any objects on the top side of Chromebase Commercial

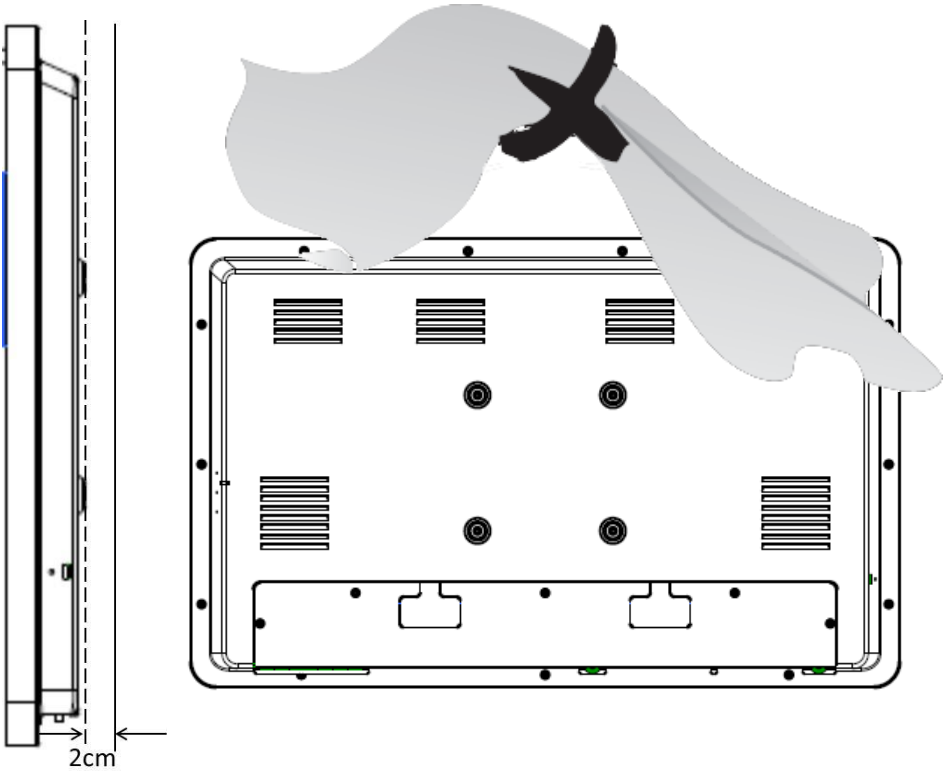

FCC notice

This device has been tested and found to comply with the limits for a Class B digital device pursuant to Part 15 of the Federal Communications Commission (FCC) Rules. These limits are designed to provide reasonable protection against harmful interference in a residential installation. This device generates, uses, and can radiate radio frequency energy and, if not installed and used in accordance with the instructions, may cause harmful interference to radio communications.

However, there is no guarantee that interference will not occur in a particular installation. If this device does cause harmful interference to radio or television reception, which can be determined by turning the device off and on, the user is encouraged to try to correct the interference by one or more of the following measures:

- Reorient or relocate the receiving antenna.
- Increase the separation between the device and receiver.
- Connect the device into an outlet on a circuit different from that to which the receiver is connected.
- Consult the dealer or an experienced radio/television technician for help.

FCC Radiation Exposure Statement:

This equipment complies with FCC radiation exposure limits set forth for an uncontrolled environment.

This equipment should be installed and operated with minimum distance 20cm between the radiator & your body.

Notice: Shielded cables

All connections to other computing devices must be made using shielded cables to maintain compliance with FCC regulations.

Notice: Peripheral devices

Only peripherals (input/output devices, terminals, printers, etc.) certified to comply with Class B limits may be attached to this equipment. Operation with non-certified peripherals is likely to result in interference to radio and TV reception.

Caution

Changes or modifications not expressly approved by the manufacturer could void the user's authority, which is granted by the FCC, to operate this computer.

Operation conditions

This device complies with Part 15 of the FCC Rules. Operation is subject to the following two conditions: (1) this device may not cause harmful interference, and (2) this device must accept any interference received, including interference that may cause undesired operation.

Notice: Canadian users

This Class B digital apparatus complies with Canadian ICES-003.

This device complies with Industry Canada licence-exempt RSS standard(s).

Operation is subject to the following two conditions:

- (1) This device may not cause interference, and
- (2) This device must accept any interference, including interference that may cause undesired operation of the device.

Le présent appareil est conforme aux CNR d'Industrie Canada applicables aux appareils radio exempts de licence.

L'exploitation est autorisée aux deux conditions suivantes:

- (1) l'appareil ne doit pas produire de brouillage, et
- (2) l'utilisateur de l'appareil doit accepter tout brouillage radioélectrique subi, même si le brouillage est susceptible d'en compromettre le fonctionnement.

This device complies with RSS 247 of Industry Canada. This Class B device meets all the requirements of the Canadian interference-causing equipment regulations.

Cet appareil numérique de la Classe B respecte toutes les exigences du Règlement sur le matériel brouilleur du Canada.

IC Radiation Exposure Statement

This equipment complies with IC RSS-102 radiation exposure limit set forth for an uncontrolled environment. This equipment should be installed and operated with minimum distance 20cm between the radiator and your body.

Déclaration d'exposition à la radiation : Cet équipement respecte les limites d'exposition aux rayonnements IC définies pour un environnement non contrôlé. Cet équipement doit être installé et mis en marche à une distance minimale de 20 cm qui sépare l'élément rayonnant de votre corps.

L'émetteur ne doit ni être utilisé avec une autre antenne ou un autre émetteur ni se trouver à leur proximité.

The device for the band 5150-5250 MHz is only for indoor usage to reduce potential for harmful interference to co-channel mobile satellite systems.

les dispositifs fonctionnant dans la bande 5150-5250 MHz sont réservés uniquement pour une utilisation à l'intérieur afin de réduire les risques de brouillage préjudiciable aux systèmes de satellites mobiles utilisant les mêmes canaux.

Under Industry Canada regulations, this radio transmitter may only operate using an antenna of a type and maximum (or lesser) gain approved for the transmitter by Industry Canada. To reduce potential radio interference to other users, the antenna type and its gain should be so chosen that the equivalent isotropically radiated power (e.i.r.p.) is not more than that necessary for successful communication.

Antenna Type : Printed antenna

Gain : 2 dBi

Conformément à la réglementation d'Industrie Canada, le présent émetteur radio peut fonctionner avec une antenne d'un type et d'un gain maximal (ou inférieur) approuvé pour l'émetteur par Industrie Canada. Dans le but de réduire les risques de brouillage radioélectrique à l'intention des autres utilisateurs, il faut choisir le type d'antenne et son gain de sorte que la puissance isotrope rayonnée équivalente (p.i.r.e.) ne dépasse pas l'intensité nécessaire à l'établissement d'une communication satisfaisante.

Antenna Type : Printed antenna

Gain : 2 dBi

2. Packing List

2-1. Standard Accessories

- a. System
- b. DB9 (RS232) to RJ50 Cable
- c. Power adapter (90W)
- d. Power cord
- e. Button tool, M4 Screw x 4, Washer x 8, Tie x 3
- f. Manual
- g. Warranty Card

a.



b.



c.



d.



e. Button tool



M4 Screw x 4



Washer x 8



Tie x 3



f.



g.



Note:

The pictures may look slightly different from the product you purchased, due to our constant efforts in improving our products.

2-2. Optional Accessories

a. Floor Stand

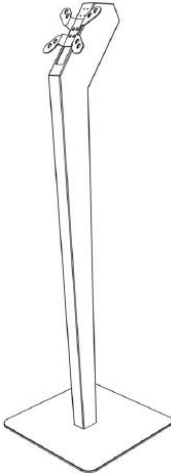

b. Desktop Stand

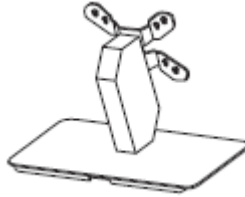

c. Ultra Slim Wall Mount

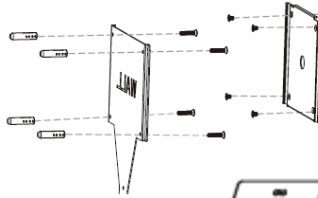

d. RJ50-RJ12 Converter Box



e. RJ50 to DB9 Power Cable

Blue Color (DB9 Pin9 have DC +12V/1A)

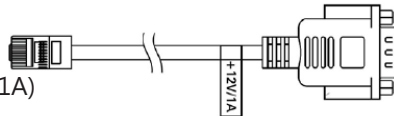

e. RJ50 to DB9 Power Cable

Gray color (DB9 Pin9 have DC +5V/1A)

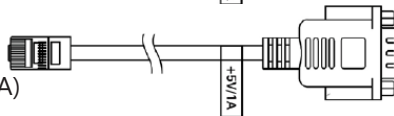

Note:

Please set up Chromebase Commercial as landscape, for safety reason no allow turn it to portrait.

Please buy one extra DC cable if you want leverage PC DC power.

Product Introduction

3-1. Outlook View

Front Side

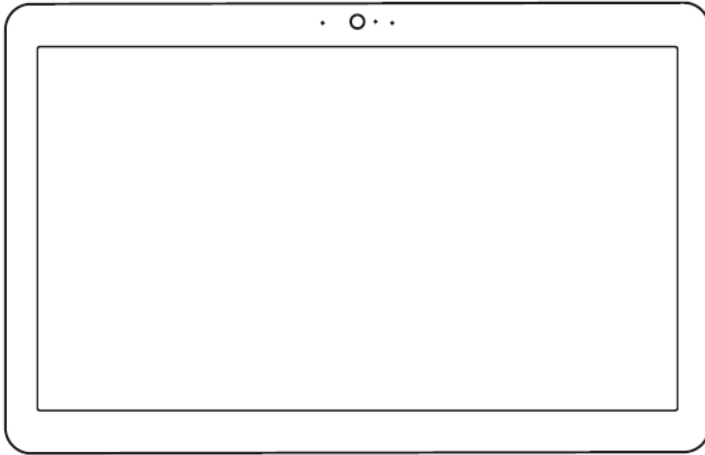

Rear Side

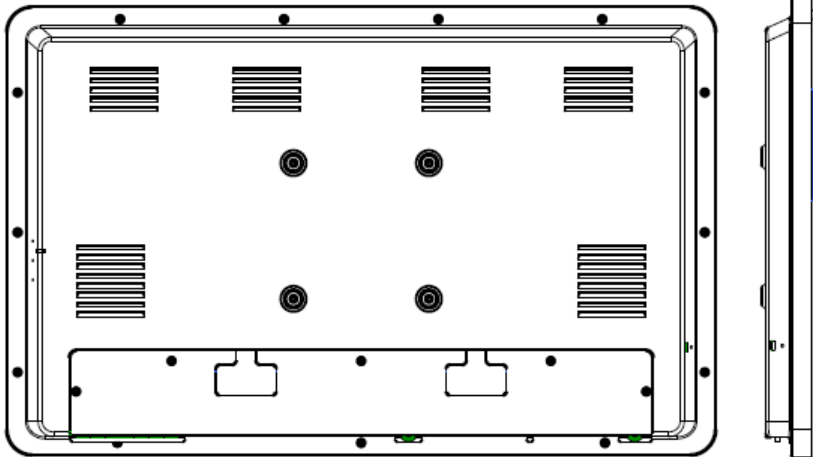

3-2. Getting to know your Chromebase Commercial

Please use attached tool or paper clip to insert into labeled holes to amend the following settings.

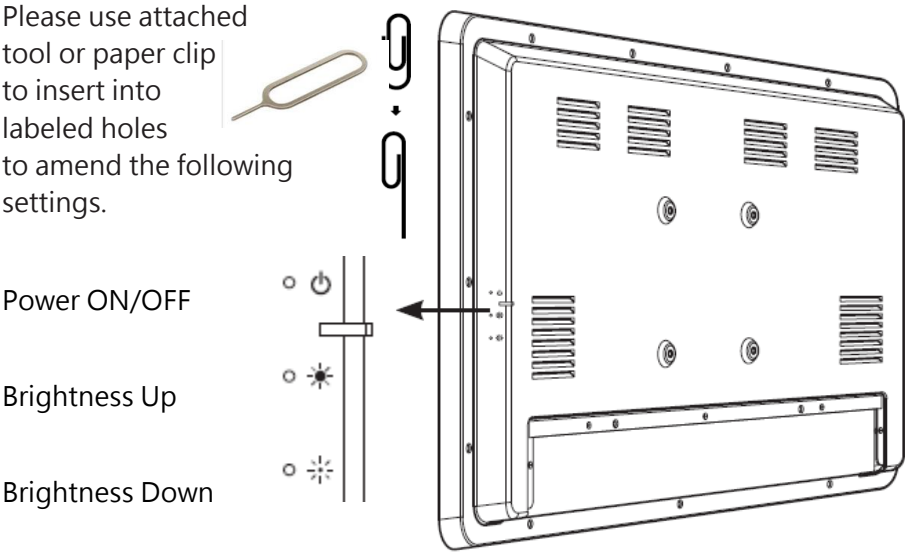

Power button

The power button allows you to turn the Chromebase Commercial on or off. You can use the power button to put your Chromebase Commercial to sleep mode or hold the clip in the power button for four (4) seconds to force shutdown your Chromebase Commercial.

IMPORTANT!

Forcing the system to restart may result in data loss. We strongly recommend that you back up your data regularly.

Brightness button

The Brightness button allows you to adjust the brightness levels of the Chromebase Commercial.

Caution:

When you install devices or cables, please ensure that DC plug is removed prior to plugging in powered devices.

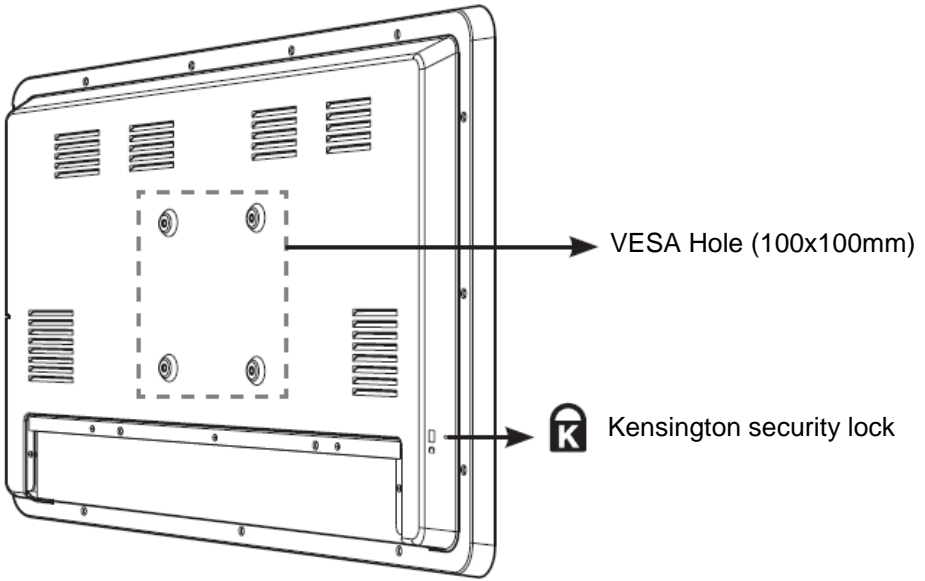

Kensington security Lock

The Kensington security slot allows you to secure your Chromebase using Kensington® security products.

VESA Hole

The VESA standard defines dimensions of a display's four-hole. The Chromebase Commercial VESA 100x100mm hole allows you to screw in M4 (Deep 3.5mm) products.

Rear side

Air vent holes

The air vent holes allow cooler air to enter your Chromebase Commercial chassis.

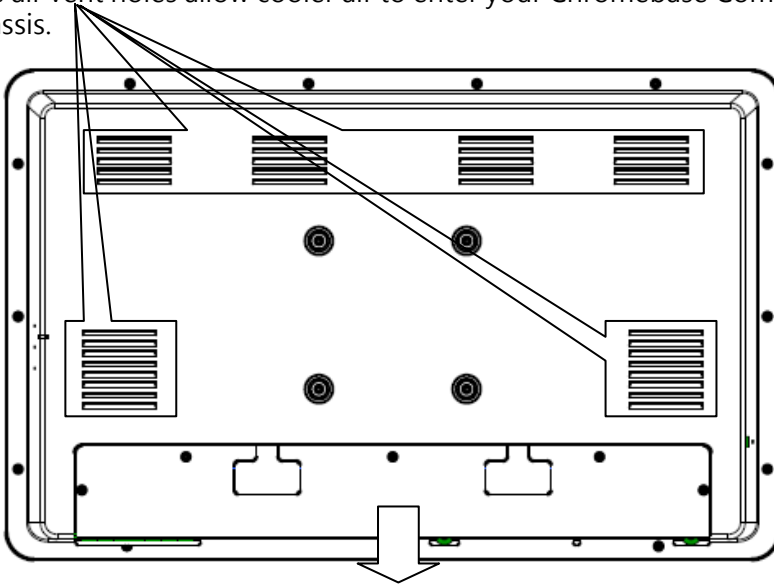

Remove I/O Cover

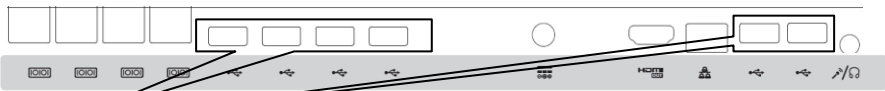

USB 2.0. These ports also support the Battery Charging 1.2 technology that allows you to charge your USB devices.



Power input

The supplied power adapter converts AC power to DC power for use with this jack. Power supplied through this jack supplies power to the Chromebase Commercial. To prevent damage to the Chromebase Commercial, always use the supplied power adapter.

WARNING!

The power adapter may become warm to hot when in use. Do not cover the adapter and keep it away from your body.

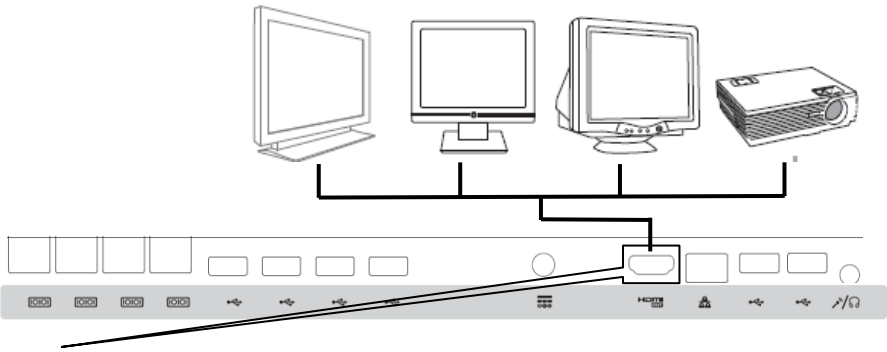

HDMI port

The HDMI (High Definition Multimedia Interface) port supports a Full-HD device such as an LCD TV or monitor to allow viewing on a larger external display.



LAN port

The 8-pin RJ-45 LAN port supports a standard Ethernet cable for connection to a local network.



Headphone/Mic Audio Out/In jack

The stereo headphone jack is used to connect the system's audio out signal to amplified speakers (headphones) or Microphone.

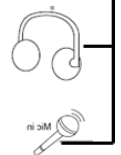



RS232 (RJ50 Type) Port

These ports also support the RS232 technology that allows you to connect your RS232 devices.

The Pin Define as below

RJ50 Pin	RS232	DB9 Pin
2	DCD#	1
4	RX#	2
6	TX#	3
8	DTR#	4
9	GND	5
3	DSR#	6
5	RTS#	7
7	CTS#	8
10	RI#	9
1 (DC 12V)		

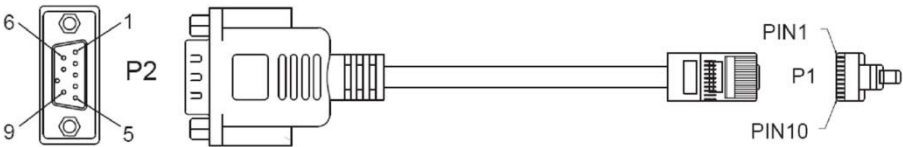

RS232 Pin Definition

Pin	Signal	Pin	Signal
1	Data Carrier Detect	6	Data Set Ready
2	Received Data	7	Request to Send
3	Transmitted Data	8	Clear to Send
4	Data Terminal Ready	9	Ring Indicator
5	Signal Ground		

Getting started

Connect the AC power adapter to your Chromebase Commercial:
Plug the AC power cord into a 100 V~240 V power source.

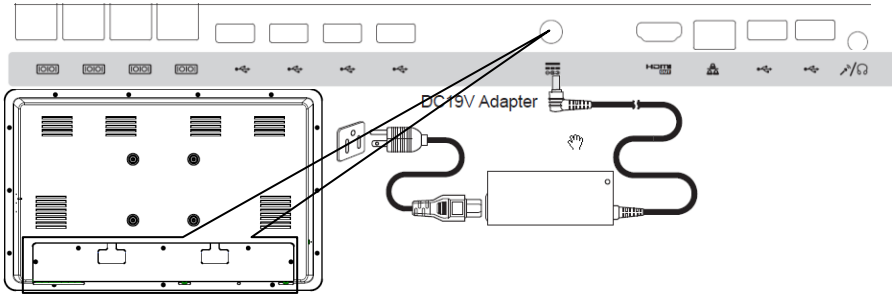

- Connect the DC power connector into your Chromebase Commercial (DC) input port.

IMPORTANT!

- Use only recommended adapter and cable that came with your Chromebase Commercial.
- We strongly recommend that you use a grounded wall socket while using your Chromebase Commercial.
- The socket outlet must be easily accessible and near your Chromebase Commercial.
- To disconnect your Chromebase Commercial from its main power supply, unplug your Chromebase Commercial from the power socket.

NOTE:

Power adapter information:

- Input voltage: 100-240 Vac
- Input frequency: 50-60 Hz
- Rating output current: 4.74A (90 W)
- Rating output voltage: 19 V

3-3. Dimensions

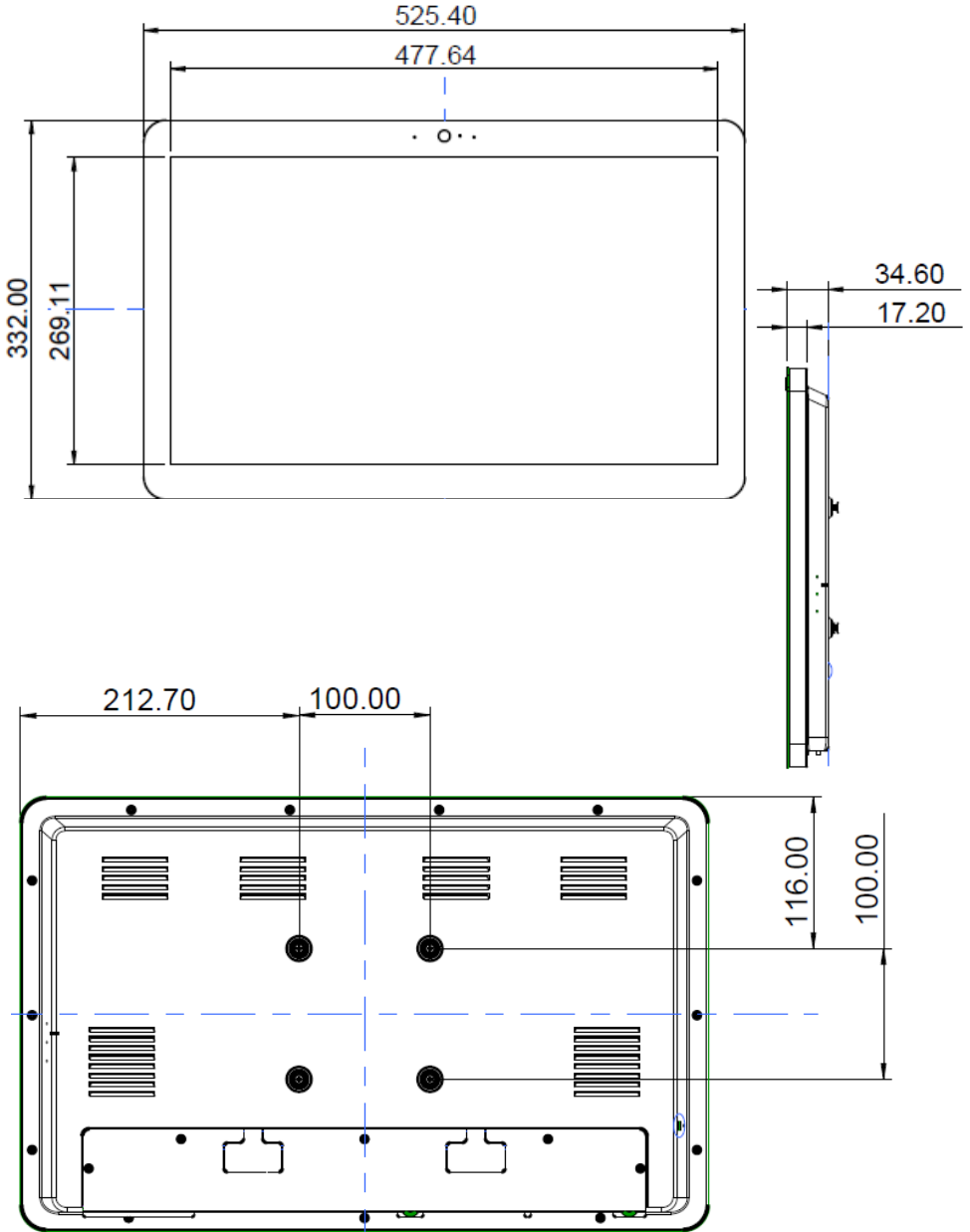

3.4. Peripheral Installation

Wall Mount Kit Assembly

1. Fix the wall-mount bracket onto the wall.
2. Place the VESA bracket onto the VESA mounting holes on the system and fasten the screws (x4).
3. Align the VESA bracket with the system into the wall mount bracket and make sure they are well connected.

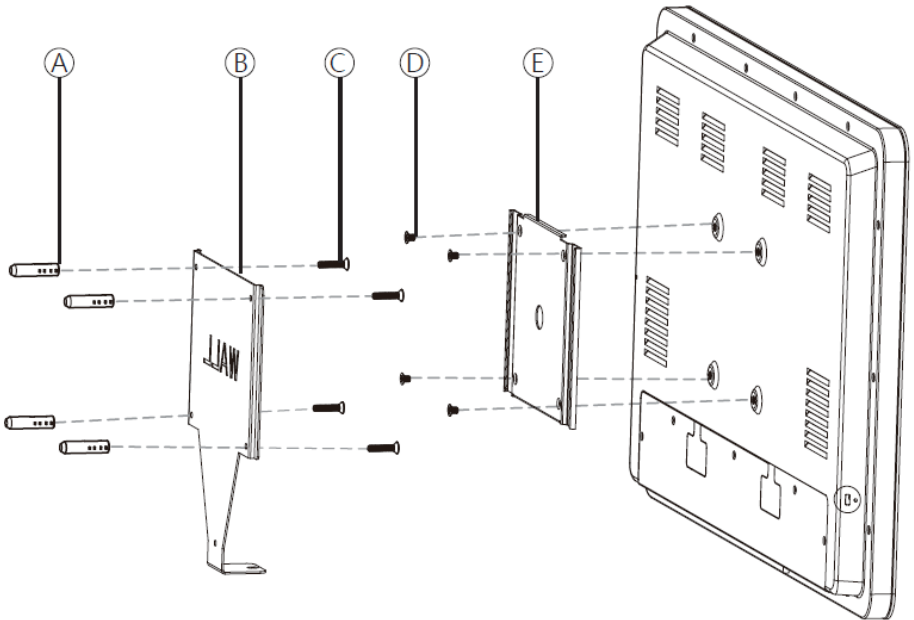

A: Install in Wall

B: Install to Wall side

C: Screw in A

D: Screw in System

E: Install to System side

4. Declaration



Declaration of Conformity

This device complies with Part 15 of the FCC Rules. Operation is subject to the following two conditions: (1) this device may not cause harmful interference, and (2) this device must accept any interference received, including interference that may cause undesired operation.

Responsible Party Name:	AOPEN Inc.
Address:	5F., No.15, Ln. 128, Sinhu 1st Rd., Neihu District, Taipei City 114, Taiwan R.O.C.
Phone/Fax No:	+886-2-7710-1195/+886-2-7710-1187
Product Name:	Chromebase Comercial
Model Name:	WT22M-FBG

We, AOPEN Inc., hereby declare that the above product and model was tested conforming to the applicable FCC Rules.

Signature: Ted Tsai

Date: 5/25/2015

Print Name: Ted Tsai

Title: G.M. of DDS Unit

Declaration of Conformity

We,

AOPEN Inc.

5F., No.15, Ln. 128, Sinhu 1st Rd., Neihu District, Taipei City 114, Taiwan R.O.C.

Declares under our sole responsibility that the product:

Product Name:

Chrombase Comercial

Model Name:

WT22M-FBG

To which this declaration relates is in conformity with the following standards or other normative documents:

EN300328 V1.8.1

EN301489-1 V1.9.2/-17 V2.2.1

EN301893 V1.7.1

EN55022:2010+AC:2011 Class B

EN55024:2010

EN61000-3-2:2006+A1:2009+A2:2009 ; EN61000-3-3:2013

EN61000-4-2:2009/-3:2006+A1:2008+A2:2010/-4:2012/-5:2006/-6:2014

/-8:2010/-11:2004

EN60950-1:2006+A11:2009+A1:2010+A12:2011+A2:2013

Regulation (EC) No. 617/2013

We, AOPEN Inc., hereby declare that the above product and model was tested conforming to the applicable Rules of EMC Directive 2004/108/EC, Low Voltage Directive 2006/95/EC, R&TTE Directive 1995/5/EC, RoHS Directive 2011/65/EU and Directive 2009/125/EC for energy-related product.

Year to begin affixing CE marking 2015



Signature: Ted Tsai

Date: 5/25/2015

Print Name: Ted Tsai

Title: G.M. of DDS Unit

5. Contact Information

AOPEN America
AOPEN America Inc.
2890 Zanker Road, Suite 101
San Jose, CA 95134
USA
Telephone: (+1) 408-586-1201

AOPEN Australia and New Zealand
AOPEN ANZ
Aopen Australia & New Zealand
Level 2, 6 Palmer Parade
Cremorne VIC 3121, Australia.
Telephone: (+61) 3 9427 7379

AOPEN Europe
AOPEN Computer BV
Stadionlaan 151-153
5246 JT Rosmalen
The Netherlands
Telephone: (+31) 73 646 6400

AOPEN Japan
AOPEN Japan Corp.
3F, Daiichi-denpa Bldg, 2-4-4, Sotokanda,
Chiyoda-ku, Tokyo 101-0021
Japan
Telephone: (+81) 3 5298 1668

AOPEN Inc.
AOPEN Inc.
5F., No.15, Ln. 128, Sinhu 1st Rd., Neihu District,
Taipei City 114,
Taiwan (R.O.C.)
Telephone: (+886) 2 7710 1195

AOPEN Taiwan
AOPEN Great Connection Corporation
5F., No.15, Ln. 128, Sinhu 1st Rd., Neihu District,
Taipei City 114,
Taiwan (R.O.C.)
Telephone: (+886) 2 7710 1195

6. Chrome Care

Please contact your authorised reseller or authorised distributor in the first instance for all warranty queries.

For direct AOPEN Care in regard to AOPEN chrome products please see below:

Australia/ News Zealand

chromecare-au@aopen.com

Americas - including South America, Canada

chromecare-usa@aopen.com

Europe

chromecare-eu@aopen.com

Japan

chromecare-jp@aopen.com

Asia - Africa

chromecare-asia@aopen.com

All other areas: chromecare-global@aopen.com

Part No.:

Doc. No.: 159-001-101