

Installation Guide

Safety and Compliance

FCC Compliance

This equipment has been tested and found to comply with the limits for a Class B digital device, pursuant to Part 15 of the FCC Rules. These limits are designed to provide reasonable protection against harmful interference when the equipment is operated in a commercial environment. This equipment generates, uses, and can radiate radio frequency energy and, if not installed and used in accordance with the Installation Manual, may cause harmful interference to radio communications. Operation of this equipment in a residential area is likely to cause harmful interference in which case the user will be required to correct the interference at his/her own expense.

CAUTION: Any changes or modifications not expressly approved by ARRIS could void the user's authority to operate this equipment under the rules and regulations of the FCC.

Canadian Compliance

This Class A digital device complies with Canadian ICES-003.

Cet appareil numérique de la classe A est conforme à la norme NMB-003 du Canada.

Housing Instructions

This document contains information about installing the OG1600.

Preparing for Installation (page 1)

Mounting the Housing (page 2)

Connecting the Plant Cable Assembly (page 3)

OG1600 LEDs (page 4)

CAUTION ARRIS Outdoor Gateways are designed for an operating environment of -10°C to +55°C. The Mil Spec Hdbk 217 states that a 9°C increase in device operating environments will reduce the product's reliability (and projected lifetime) by 50%. Therefore, you should take proper care to maximize airflow around the Outdoor Gateway and to minimize ambient temperatures.

Preparing for Installation

To prepare the OG1600 housing for installation

The OG1600 Outdoor Gateway is delivered without the strand mount assembly attached to the housing base.

1. Inspect the shipping carton and ensure that the strand mount assembly is present.
 - a. The strand mount assembly is available from ARRIS and consists of:
 - Two offset brackets
 - Two strand clamps
 - Two 1/4" x 1.25" length bolts

Contact ARRIS if you need to order a strand mount assembly.

2. Inspect the outside of the housing. Check the convection fins, coaxial cable entry ports, captive lid bolts, and all service entry points for damage.

Mounting the Housing

IMPORTANT: The OG1600 Outdoor Gateway is not field-serviceable.

The following sections describe how to mount the OG1600.

Strand Mounting

Before you strand mount the housing, follow the instructions below to attach the strand mount brackets to the base.

1. Attach each strand mount assembly to the housing base, using the 1/4" x 0.625" length bolts that are already installed in the top of the OG1600 chassis.

The following figure shows the strand mount brackets attached to the OG1600 housing.

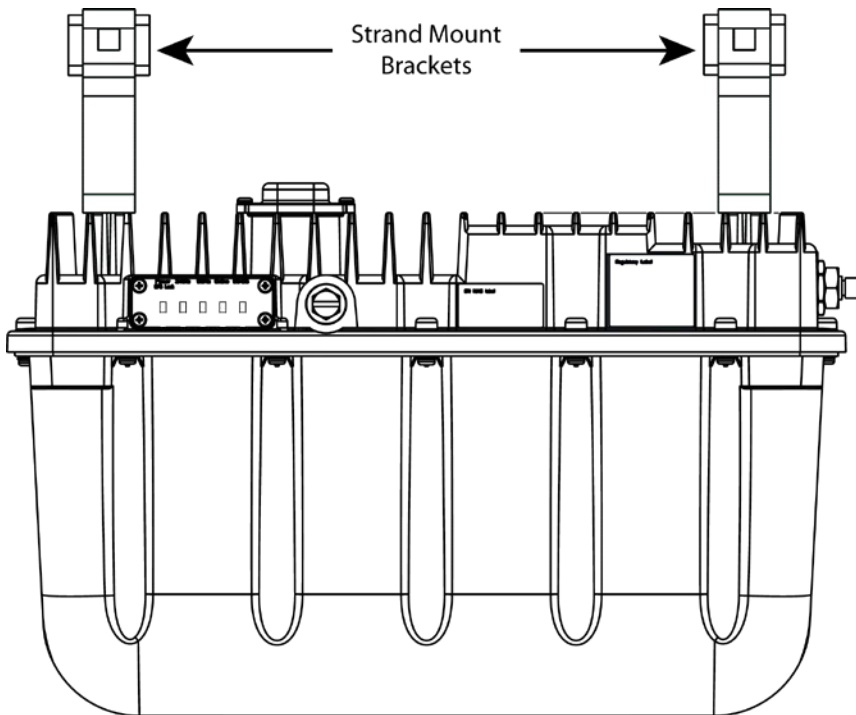

Figure 1: Location of strand mount brackets attached to the OG1600 housing

2. Torque each bolt to between 4 and 6 ft-lbs (between 5.4 and 8.1 N•m)
3. Loosely attach the strand clamps to the strand mount assemblies using the 1/4" x 1.25" length bolts included with the strand mount assembly, as shown in the following figure.

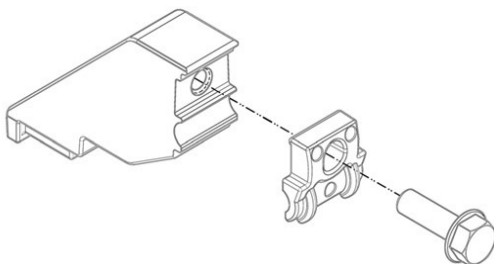

Figure 2: Attaching strand clamps to strand mount brackets

To strand mount the housing:

1. Lift the Outdoor Gateway so that the clamps are level with the strand, and slide the Outdoor Gateway back until the strand engages the strand clamps.
2. Do not tighten the hex head bolts at this time. Keeping the bolts loose enables the clamps to slide along the strand wire until the housing finally is positioned with respect to the cables.
3. Verify that the Outdoor Gateway is within 5 degrees of hanging vertically.
4. When the housing is in the required position, torque the two strand clamp bolts to between 4 and 6 ft-lbs (between 5.4 and 8.1 N•m).

Grounding the Housing

The aerial metal strand connections will serve as connection to ground.

Connecting the Plant Cable Assembly

The OG1600 includes an F-type connector which can be used to add the plant cable assembly. You will need to remove the plastic cap covering this connector before you can connect to the plant cable assembly.

Important: The OG1600 is designed to be mounted near the cable plant tap in order to minimize the length of coaxial cable needed to connect. Extended lengths of coaxial cable can reduce the DOCSIS receive sensitivity of the Outdoor Gateway.

OG1600 LEDs

The OG1600 Outdoor Gateway includes several LED indicator lights on the outside of the case to assist in troubleshooting.

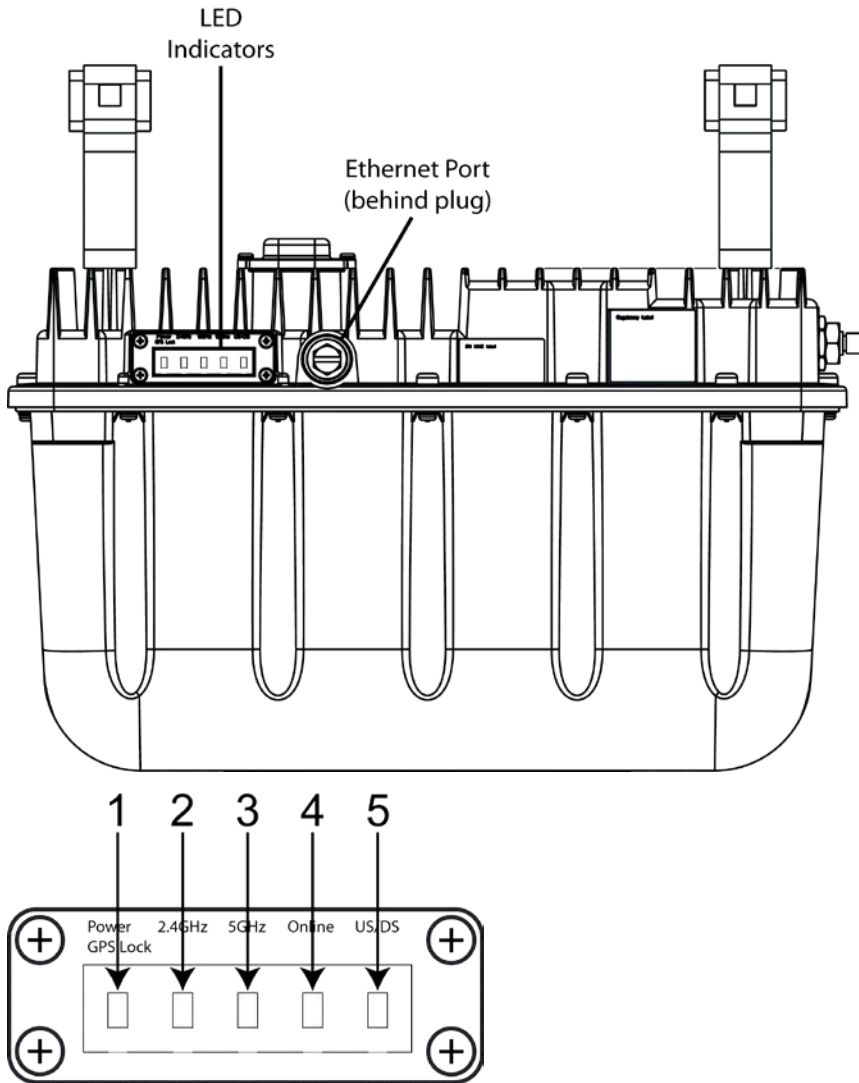

1. **Power:** blinks to indicate that AC power is available to the unit. A solid (non-blinking) LED indicates that GPS lock has been acquired.
2. **2.4GHz:** indicates the status of the 2.4 GHz wireless LAN.
3. **5GHz:** indicates the status of the 5 GHz wireless LAN.
4. **Online:** indicates internet data transmission status.
5. **US/DS:** indicates upstream/downstream connectivity.

LED Behavior: Normal Operation

| Mode | Power LED | 2.4G LED | 5G LED | Online | US/DS |
|------------------|---|---|---|-------------------------|---------------------------------------|
| AC Power | On = Unit is up and running Flash = GPS scan in progress | On = 2.4G Wifi Enabled Flash = Client activity Off = 2.4G Wifi Disabled | On = 5G Wifi Enabled Flash = Client activity Off = 5G Wifi Disabled | On = Internet available | On = Connected to Internet |
| No AC Power | Off | Off | Off | Off | Off |
| Firmware upgrade | Normal Operation | Normal Operation | Normal Operation | Normal Operation | Flash = Firmware Download in Progress |

LED Behavior: Startup Sequence

| Power / GPS Lock | US/DS | Online |
|--|--|--|
| On = OG1600 has power | Slow Flash (1 / Second) = Downstream acquisition in progress | Off |
| Flash = GPS scan in progress | On (Until Upstream Acquisition Starts) | Off |
| On = OG1600 is up and GPS scan is done | Fast Flash (3 / Second) = Upstream acquisition in progress | Off |
| | On (Upstream acquisition complete) | Slow Flash (during initialization / IP acquisition) On (when modem obtain IP address) |