

# Harmony Series Mortise Lock Installation Instructions

A8027G  
06/17

## Table of Contents

<b>1</b>	<b>Warning .....</b>	<b>2</b>
<b>2</b>	<b>General Description .....</b>	<b>3</b>
<b>3</b>	<b>Technical Specifications .....</b>	<b>3</b>
<b>4</b>	<b>Regulatory Specifications .....</b>	<b>3</b>
<b>5</b>	<b>Parts Breakdown .....</b>	<b>4</b>
<b>6</b>	<b>Installation Instructions .....</b>	<b>8</b>
<b>7</b>	<b>Wiring Diagrams .....</b>	<b>16</b>
<b>8</b>	<b>Mechanical Operational Check .....</b>	<b>18</b>
<b>9</b>	<b>Electrical Operational Check .....</b>	<b>18</b>

### 1 Warning

Changes or modifications to this unit not expressly approved by the party responsible for compliance could void the user's authority to operate the equipment.

This device complies with Part 15 of the FCC Rules. Operation is subject to the following two conditions: (1) this device may not cause harmful interference, and (2) this device must accept any interference received, including interference that may cause undesired operation.

Note: This equipment has been tested and found to comply with the limits for a Class B digital device, pursuant to Part 15 of the FCC Rules. These limits are designed to provide reasonable protection against harmful interference in a residential installation.

This equipment generates, uses and can radiate radio frequency energy and if not installed and used in accordance with the instructions, may cause harmful interference to radio communications. However, there is no guarantee that the interference will not occur in a particular installation. If this equipment does cause harmful interference to radio or television reception, which can be determined by turning the equipment off and on, the user is encouraged to try to correct the interference by one or more of the following measures:

- Reorient or relocate the receiving antenna
- Increase the separation between the equipment and receiver
- Connect the equipment into an outlet on a circuit different from that to which the receiver is connected
- Consult the dealer or an experienced technician for help

**Contains FCC ID: U4A-SCSEHF**

**Contains IC: 6982A-SCSEHF**

The term "IC:" before the radio certification number only signifies that Industry Canada technical specifications were met. This Class B digital apparatus meets all requirements of the Canadian Interference Causing Equipment Regulations. Operation is subject to the following two conditions: (1) this device may not cause harmful interference, and (2) this device must accept any interference received, including interference that may cause undesired operation.

Cet appareillage numérique de la classe B répond à toutes les exigences de l'interférence canadienne causant des règlements d'équipement. L'opération est sujette aux deux conditions suivantes: (1) ce dispositif peut ne pas causer l'interférence nocive, et (2) ce dispositif doit accepter n'importe quelle interférence reçue, y compris l'interférence qui peut causer l'opération peu désirée.

Any retrofit or other field modification to a fire rated opening can potentially impact the fire rating of the opening, and SARGENT Manufacturing makes no representations or warranties concerning what such impact may be in any specific situation. When retrofitting any portion of an existing fire rated opening, or specifying and installing a new fire-rated opening, please consult with a code specialist or local code official (Authority Having Jurisdiction) to ensure compliance with all applicable codes and ratings.



Observe precautions for handling electrostatic sensitive devices.

## 2 General Description

The SARGENT Harmony Series H2 mortise lock is designed to interface with existing Wiegand Electronic Access Control (EAC) panels. The reader requires 12 or 24VDC for power and is compatible with HID® iCLASS® 13.56MHz technology. Harmony Series technology is backed by SARGENT's Grade 1 hardware.

The mortise lock comes with Request to Exit (RX) monitoring within the lock body and operates from 12-24VDC. The Harmony H2 iCLASS reader provides visual (LED) and audible indicators of lock position (locked/unlocked). Gasket required for exterior door applications.

## 3 Technical Specifications

- Latch: Stainless steel, 3/4" projection, one-piece
- Deadbolt: One-piece hardened stainless steel
- Guardbolt: Stainless steel, non-handed
- Handed: Easily field reversible without opening case
- Case: 12 gauge heavy duty wrought steel
- Outside lever controlled by any 13.56MHz HID iCLASS Wiegand credential
- Field-selectable to Fail Safe or Fail Secure
- Door position switch within lock body
- Inside lever provides RX signal and retracts latch and deadbolt
- Lock to be configured\* as Fail Safe or Fail Secure per AHJ compliance as part of initial lock configuration
- Locks furnished for 1-3/4" doors. Other door thicknesses require confirmation with factory.

## 4 Regulatory Specifications

- Reader Draw = 150mA @12VDC / 24VDC
- Actuator Draw = 400mA inrush / 15mA continuous @12VDC / 24VDC
- Solenoid Draw = 250mA @12VDC  
500mA @24VDC

- **UL 294 Access Control Performance Ratings:**

Destructive Attack	Level I
Line Security	Level I
Endurance	Level IV
Standby Power	Level I

- ANSI/BHMA A156.25 Listed Grade 1 Compliant
- UL and CUL listed for use on Fire Doors
- This product meets the requirements of CAN/ULC-S319-05 Equipment Class I

Wiring methods shall be in accordance with the National Electrical Code (ANSI/NFPA70), CSA 22.1, Canadian Electrical Code (CEC), Part I, Safety Standard for Electrical Installations, local codes, and the authorities having jurisdiction.

## 5 Parts Breakdown

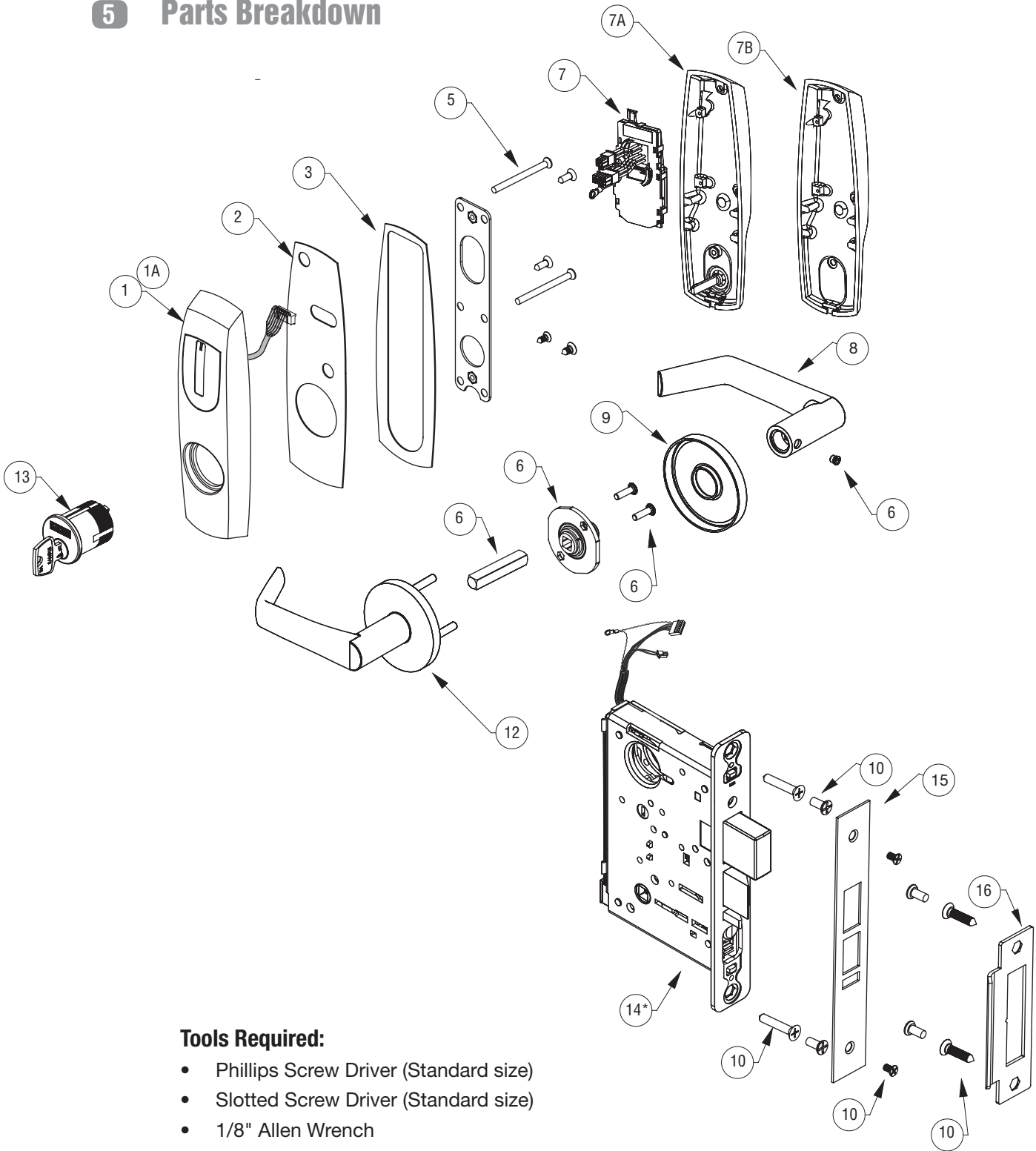

**Tools Required:**

- Phillips Screw Driver (Standard size)
- Slotted Screw Driver (Standard size)
- 1/8" Allen Wrench

Copyright © 2017, Sargent Manufacturing Company, an ASSA ABLOY Group company. All rights reserved. Reproductions in whole or in part without express written permission of Sargent Manufacturing Company is prohibited.

03/31/17

### Parts Breakdown (Continued)

Item	Part #	Description	Req.	
1	52-4039	Outside Harmony Escutcheon With Cylinder Prep	1	
1A	52-4040	Outside Harmony Escutcheon Without Cylinder Prep	1	
2	52-0796	Outside Weather Gasket	1	
3	52-0795	Inside Weather Gasket	1	
5	52-5236	Screw Pack (5A; 5B; 5C; 5D)	1	
6	82-4355	Trim Pack - Standard levers	1	
	79-2162	Trim Pack - Deco levers (shown)		
7	52-4517	H2-1A-02 Controller Assembly	1	
7A	52-5196	Inside Escutcheon w/ Turn Assembly	1	
7B	82-0706	Inside Escutcheon w/out Turn Prep	1	
8	--	Reference Harmony Series Catalog For Available Lever Styles	1	
9	--	Reference Harmony Series Catalog For Available Rose Styles	1	
10	77-4236	Mortise screw pack - specify finish (includes: wood & metal lock body screws, faceplate screws & strike screws)		
12	--	Reference Harmony Series Catalog For Available Lever Styles	1	
13	--	Reference Harmony Series Catalog For Available Cylinders (Size 43)	1	
14*	Lock Body†	H2-82270-12/24 VDC x Finish	w/out Deadbolt, Fail Safe**	1
		H2-82271-12/24 VDC x Finish	w/out Deadbolt, Fail Secure**	1
		H2-82272-12/24 VDC x Finish	w/out Deadbolt, Fail Safe, Both Levers Lock**	1
		H2-82273-12/24 VDC x Finish	w/out Deadbolt, Fail Secure, Both Levers Lock**	1
		H2-82274-12/24 VDC x Finish	w/out Deadbolt, Fail Safe**	1
		H2-82275-12/24 VDC x Finish	w/out Deadbolt, Fail Secure**	1
		H2-82280-12/24 VDC x Finish	w/ Deadbolt, Fail Safe**	1
		H2-82281-12/24 VDC x Finish	w/ Deadbolt, Fail Secure**	1
		H2-82282-12/24 VDC x Finish	w/ Deadbolt, Fail Safe, Both Levers Lock**	1
		H2-82283-12/24 VDC x Finish	w/ Deadbolt, Fail Secure, Both Levers Lock**	1
		H2-82284-12/24 VDC x Finish	w/ Deadbolt, Fail Safe**	1
H2-82285-12/24 VDC x Finish	w/ Deadbolt, Fail Secure**	1		
15	82-0579	Electrical Outside Faceplate w/ Deadbolt	1	
15A	82-0578	Electrical Outside Faceplate w/out Deadbolt	1	
16	82-0110	Strike Plate	1	
17	01-2299	#12 X 1 1/4" Phillips Flat Head Wood Screw	2	
21	A7944	Field Prep Template (Not Shown)	1	
22	4590	Door Manufacturer Template (Not Shown)	1	
23	A8027	Installation Instructions (Not Shown)	1	

\*Patent Pending - [www.assaabloydss.com/patents](http://www.assaabloydss.com/patents)

\*\*CAUTION: Not recommended for use on any door used for Life Safety Egress

†For End-of-Line Resistor and PHR locks, please consult factory

## 6 Wiring Diagrams

Product	8 PIN CONNECTOR								4 PIN CONNECTOR			
	1-Black	2-Red	3-White	4-Green	5-Orange	6-Blue	7-Brown	8-Yellow	1-Violet	2-Gray	3-Pink	4-Tan
ACCESS CONTROL DEVICES: Harmony H2 Mortise, ElectroLynx wire Color / Function assignments												
SARGENT - HARMONY SERIES H2 Mortise Bored/Exits	12/24VDC (Reader)		WIE-GAND	WIE-GAND	RX	RX	EGND	LED	12/24 VDC (LOCK RELAY)		DPS (NC)	DPS (COM)
	NEG	POS	DATA_1	DATA_0	NO/NC	COM	REF. *DIA-GRAMS	REF. *DIA-GRAMS	NEG	POS	DPS	DPS
	NEG	POS	DATA_1	DATA_0	??	COM			NEG	POS	NC	NC

\*Diagram on following page

**If your lock is configured with End of Line Resistors, reference instruction sheet A8191 for the wiring of RX & DPS outputs.**

### Reader LED Configuration

The Harmony Series reader can be configured for (3) modes of LED operation. HID Programming cards are also supported to configure the behavior for LED color activity. Call 1-800-810-WIRE for details.

#### Mode 1:

- Red LED 'ON' when powered.
- Presenting a valid credential causes LED to 'FLICKER' green and return to red state.

#### Mode 2:

- Green LED "ON" when powered.
- No Flicker after presenting valid valid credential.

Note: LED wire must be connected to circuit GROUND of the system's power supply.

#### Mode 3:

- EAC Panel controls LED operation.

Note: Control of LED is a function of the EAC panel equipment (i.e. relay) to toggle between green and red.

Note: When LED wire is tied directly into EAC panel relay, no AC signals should be applied on wire or door reader performance will be impacted.

Wire from EAC panel to door must be shielded with drain terminated at EAC panel controller

### Wire Gauge Charts

Total One-Way Length of Wire Run (ft)	Load Current @ 12VDC							
	1/4A	1/2A	3/4A	1A	1-1/4A	1-1/2A	2A	3A
100	20	18	16	14	14	12	12	10
150	18	16	14	12	12	12	10	—
200	16	14	12	12	10	10	—	—
250	16	14	12	10	10	10	—	—
300	16	12	12	10	10	—	—	—
400	14	12	10	—	—	—	—	—
500	14	10	10	—	—	—	—	—
750	12	10	—	—	—	—	—	—
1,000	10	—	—	—	—	—	—	—
1,500	10	—	—	—	—	—	—	—

Total One-Way Length of Wire Run (ft)	Load Current @ 24VDC							
	1/4A	1/2A	3/4A	1A	1-1/4A	1-1/2A	2A	3A
100	24	20	18	18	16	16	14	12
150	22	18	16	16	14	14	12	10
200	20	18	16	14	14	12	12	10
250	18	16	14	14	12	12	12	10
300	18	16	14	12	12	12	10	—
400	18	14	12	12	10	10	—	—
500	16	14	12	10	10	—	—	—
750	14	12	10	10	—	—	—	—
1,000	14	10	10	—	—	—	—	—
1,500	12	10	—	—	—	—	—	—

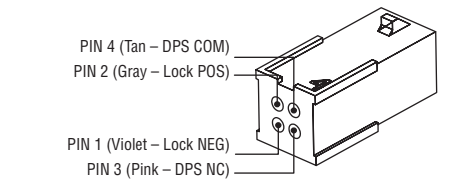
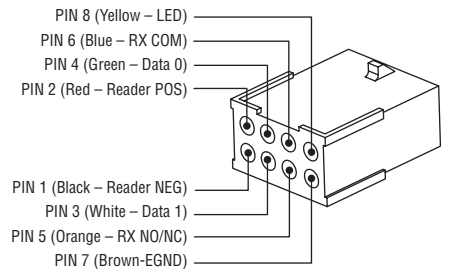



\*IMPORTANT: Pin 7 must be tied to earth ground in the access control panel.  
Failure to follow proper ESD safe grounding procedures could lead to equipment failure.

## Typical Harmony Mortise Lock Application Diagram (12/24VDC System)

Standard Application Shown - For Alternative Applications Contact 1-800-810-WIRE (9473)

Reader Electronics Require 12 or 24VDC UL294 Listed Power Supply (or UL603)

### 12/24VDC System

- Reader Draw = 150mA @12 or 24VDC
- Actuator Draw = 15mA continuous

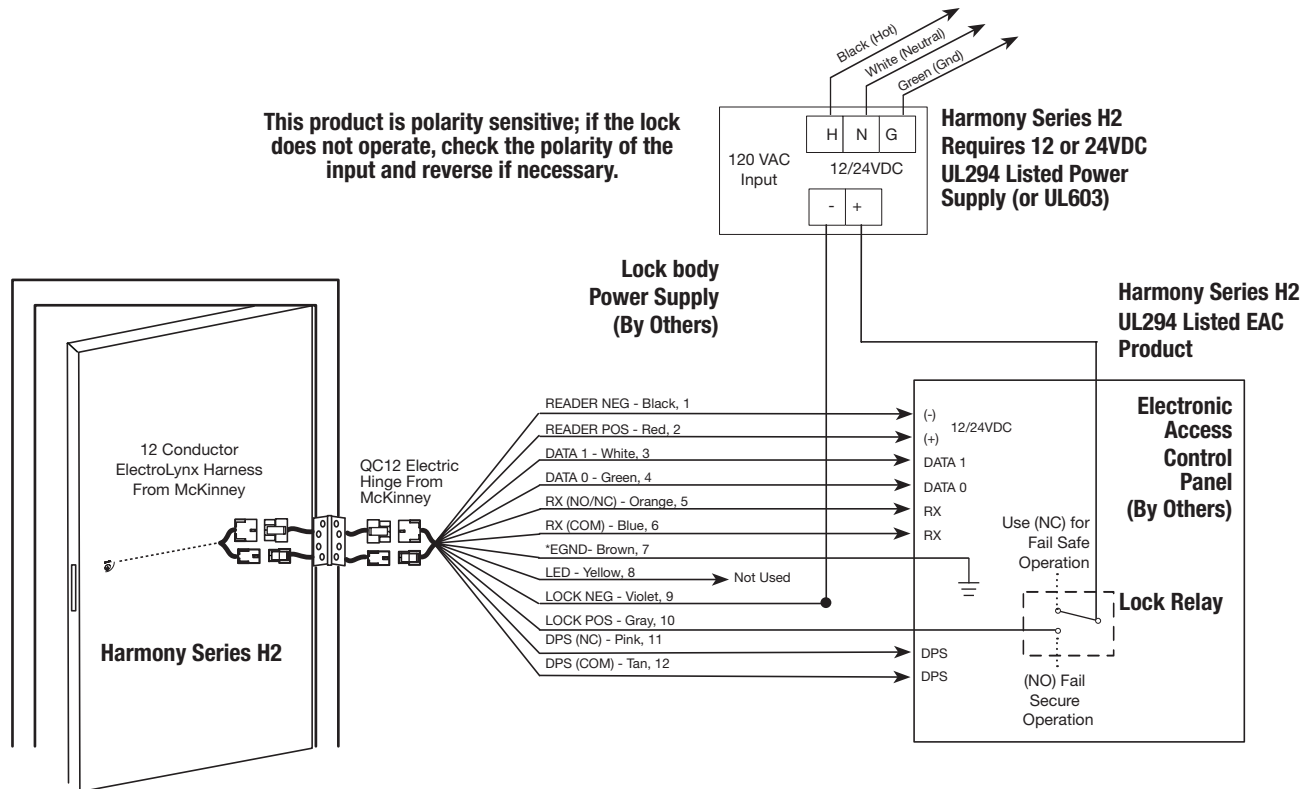

**NOTE:**

If your lock is configured with End of Line Resistors, reference instruction sheet A8191 for the wiring of RX & DPS outputs.

## 6 Installation Instructions

### 1 Door Preparation

#### A. Verify Hand and Bevel of Door

Stand on outside of locked door when determining door hand.

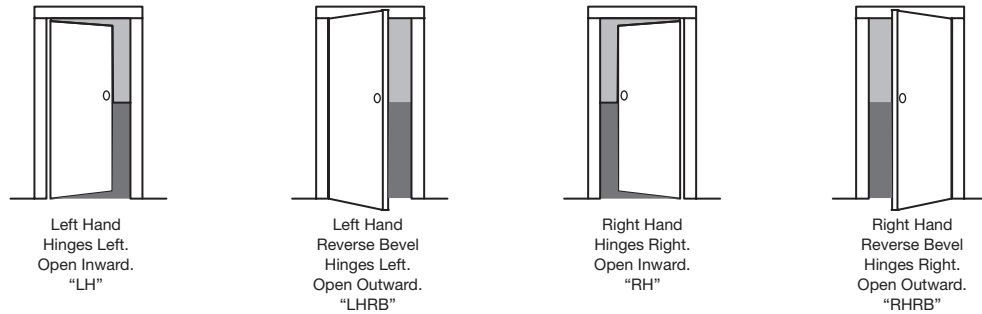

Fig. 1A

#### B. Door Preparation

Prepare door according to appropriate template. If necessary, refer to website: [www.intelligentopenings.com](http://www.intelligentopenings.com).

- Prior to installation, make sure all holes are free of burrs, debris, and sharp edges.
- If doors are not properly reinforced per ANSI 115.2, commercially available reinforcements should be installed.
- Templates:
  - Field prep: A7944 template ships with product.
  - Manufacturer: 4590 wood and metal door template.

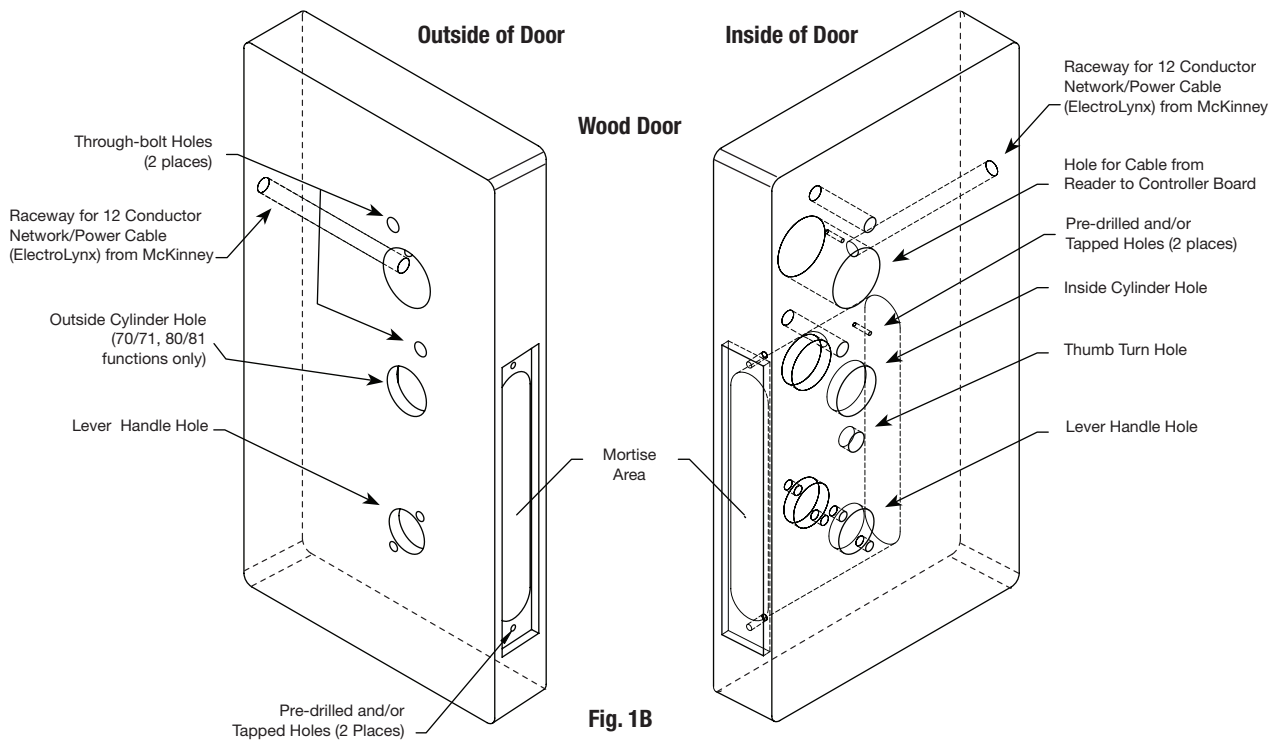

Fig. 1B



## 2 How to Change Hand of Lock body

### A. Reverse Lock Hand

Red surface of locking piece must face the outside/locked side of door. To rotate locking piece (Fig. 2A):

1. Position lock body with red surface of locking piece visible.
2. Insert blade type screwdriver into locking piece slot to rotate locking piece toward back of lock body.
3. Rotate the locking piece 180° until RED surface is on opposite side.

Note: Red indicates locked side (outside).

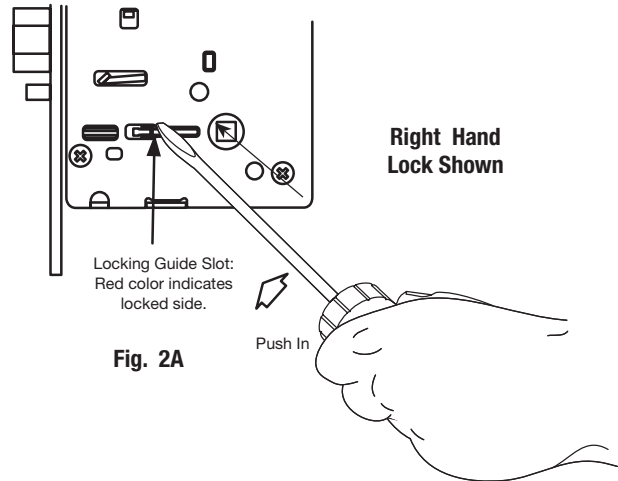

Fig. 2A

### B. Reverse Latch Hand

Beveled surface of latch must face strike (Fig. 2B).

The deadlatch is self adjusting.

To change hand of latchbolt:

1. Insert screwdriver into the spade-shaped (triangular) slot.
2. Rotate screwdriver 90° to push latch out until back of latch clears lock front; then rotate latch 180°.

Latch will then re-enter lock body.

Note: Latch cannot be unscrewed.

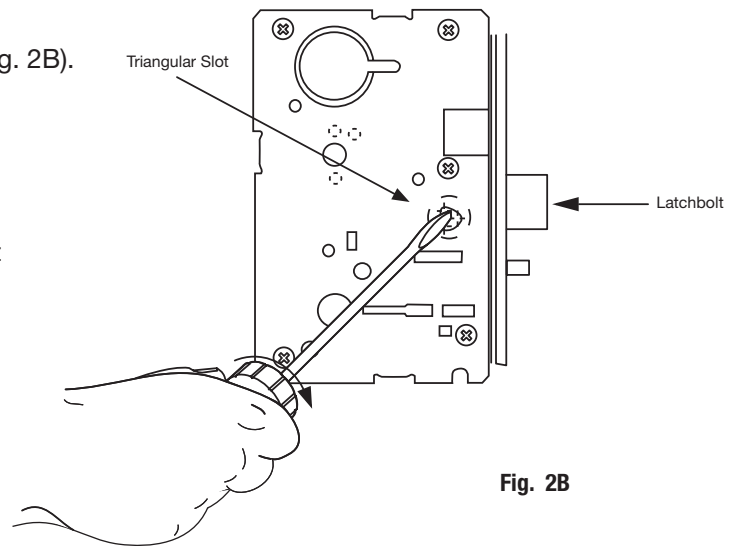
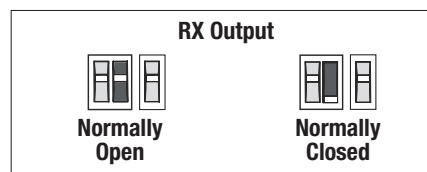
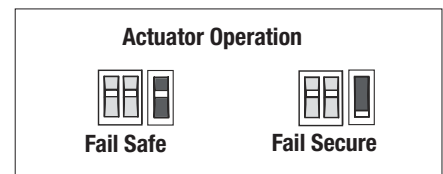
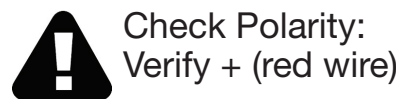
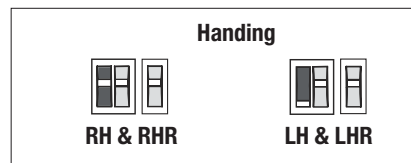
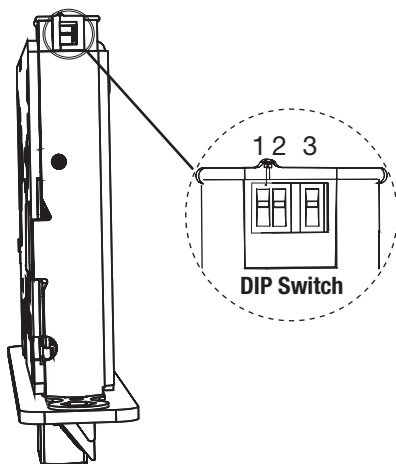

Fig. 2B

## 3 Configure the DIP Switch Settings

**IMPORTANT:** This product is built and factory tested to the configuration specified. Any change to the 3-position DIP-switch settings located at the bottom of the mortise lock body must be made prior to lock installation.



## 4 Install Lock body

1. Wires and connectors go into the mortised area and out of the inside cylinder hole.
2. Insert mortise lock body into mortise door preparation.
3. Carefully feed wires from mortise lock through the non-cylinder side hole of the door preparation.
4. Install appropriate hardware lock body screws.

**NOTE: Do not tighten screws completely at this time.**  
Cylinder should be installed prior to tightening.

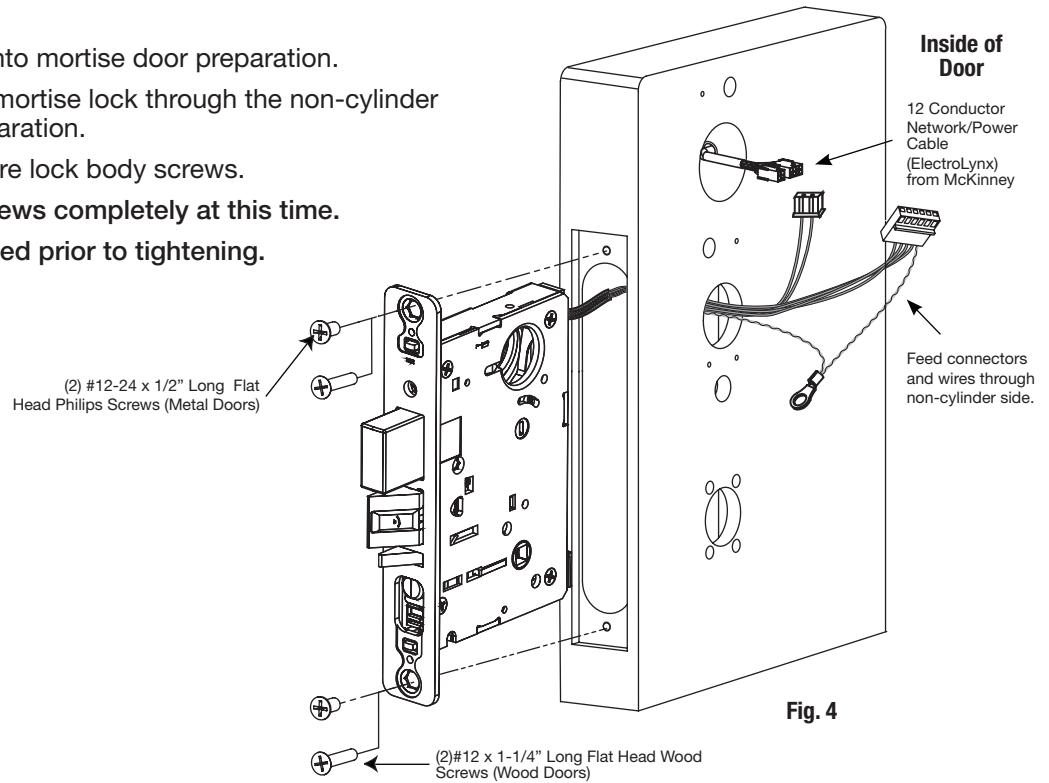

## 5 Outside Escutcheon and Mounting Plate Installation

**NOTE:** Feed mortise connectors through the corresponding hole on the mounting plate.

1. Attach the mounting plate using (2) 8-32 x 2" Phillips flat head undercut combo screws in the upper right and middle left positions of the mounting plate and (2) 8-32 x 3/8" Phillips flat head screws in the bottom positions (Fig. 5A).

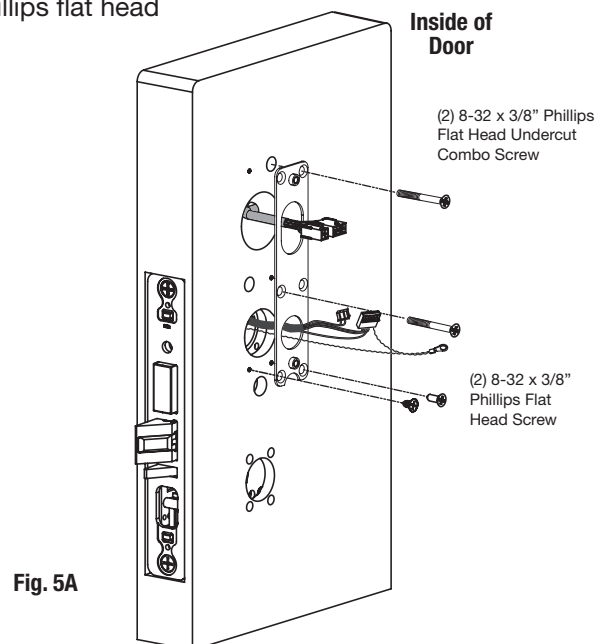

## 5 Outside Escutcheon and Inside Mounting Plate Installation (Continued)

2. Feed the reader cable located on the back of the outside escutcheon through the door prep (Fig. 5B).
3. Outside gasket must be used when installing Harmony in an outdoor application (Fig. 5B).
4. Secure the mounting plate to the outside escutcheon with (2) #8-32 x 2" flat head machine screws (Fig. 5C).

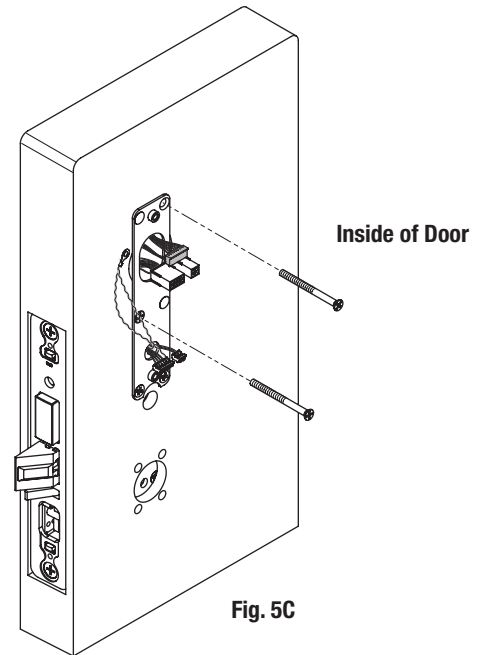
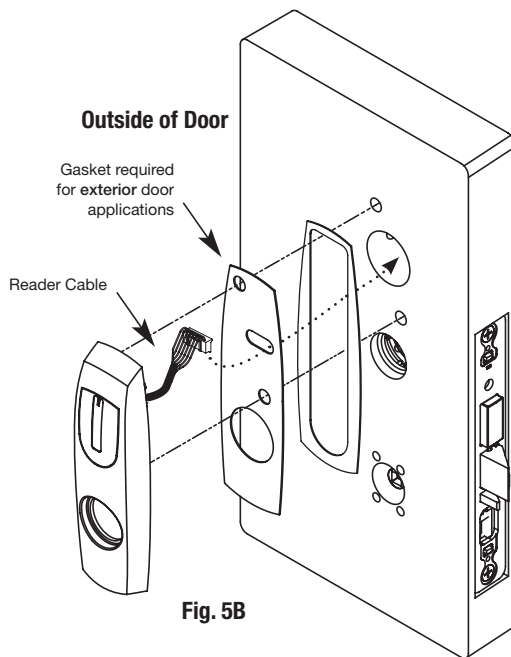

## 6 Install Inside Gasket (if necessary)

Remember to install inside gasket when lock is being used in an outdoor application.

1. Add gasket (if necessary):

Gasket fits snug around plate at top and sides, leaving room for the hole at the bottom.

2. Remove (peel) backing and place gasket on door (Fig. 6).

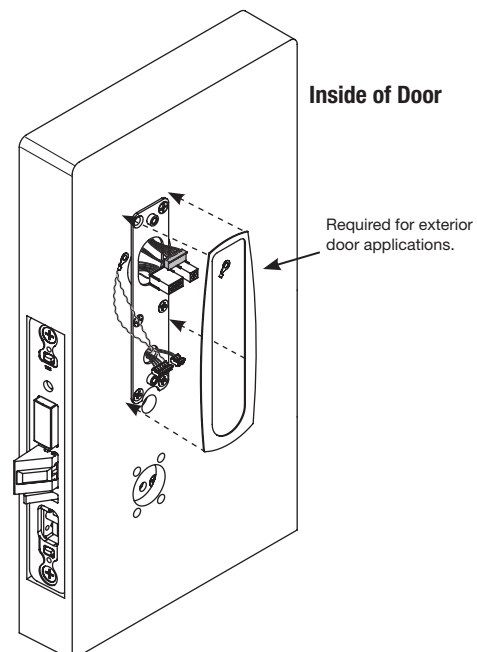

## 7 Outside Cylinder Installation

1. Verify orientation of cylinder so that SARGENT logo is right-side up (Fig. 8A).
2. Withdraw the key about 25% out of the cylinder before inserting into the escutcheon (Fig. 8B).
3. Use the key to rotate the cylinder clockwise until it is flush at the bottom and the SARGENT logo is right-side up.

Do not attempt to tighten all the way.

4. Tighten the cylinder clamp set screw to prevent unscrewing of the cylinder (Fig. 8C).

5. Test cylinder function:

- 70/71 Function: Key retracts latch.
- 80/81 Function: Key retracts latch and projects/retracts deadbolt.
- Ensure smooth operation of latchbolt and deadbolt.

NOTE: Use lever handle holes to manipulate mortise to ease thread engagement of cylinder.

Correct      Incorrect

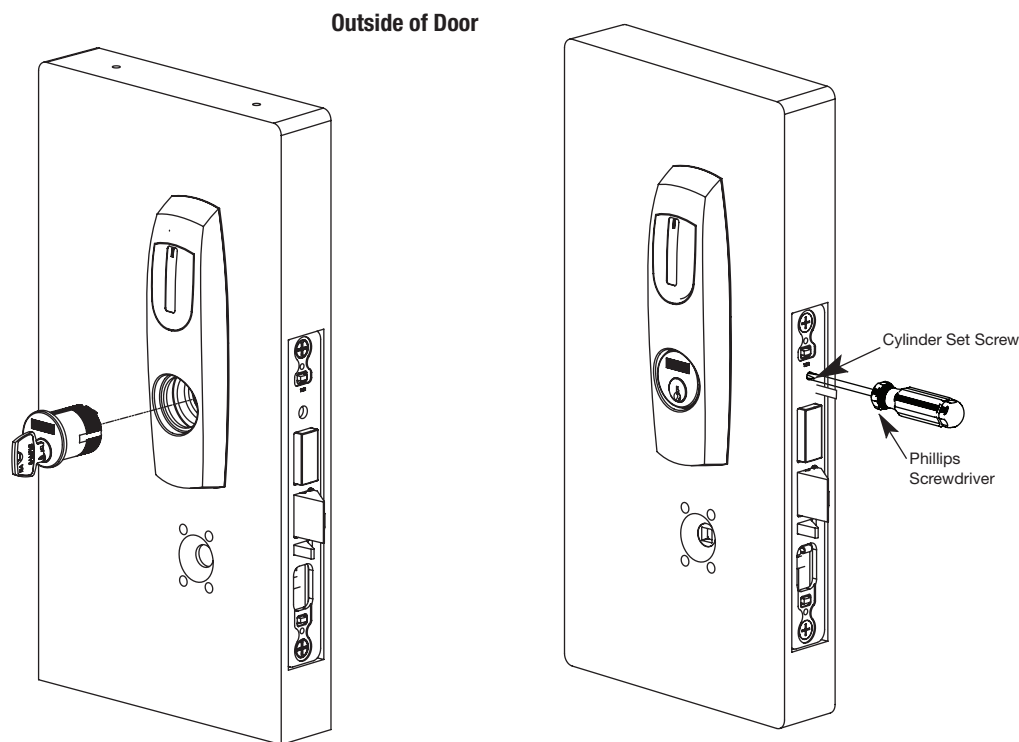

Fig. 8B

Fig. 8C

## 8 Outside Lever and Inside Adapter Plate Assembly Installation

1. With outside lever horizontal, insert the mounting post through outside of door and lock body. Make certain the lever spindle is properly engaged inside the lock body (Fig. 9A).
2. On the inside of the door, insert slotted spindle into square hole of mortise lock (Fig. 9B), with spindle slot directed away from the lock body, and aligned with the set screw hole in the inside adapter.
3. Slide inside adapter and plate assembly over spindle and loosely secure with (2) 8-32 X 5/8" Phillips oval head and lock washer machine screws.

NOTE: Ensure that position of set screw hole and spindle slot are oriented to match location of hole in the inside lever handle.

4. Securely tighten the lock body screws.

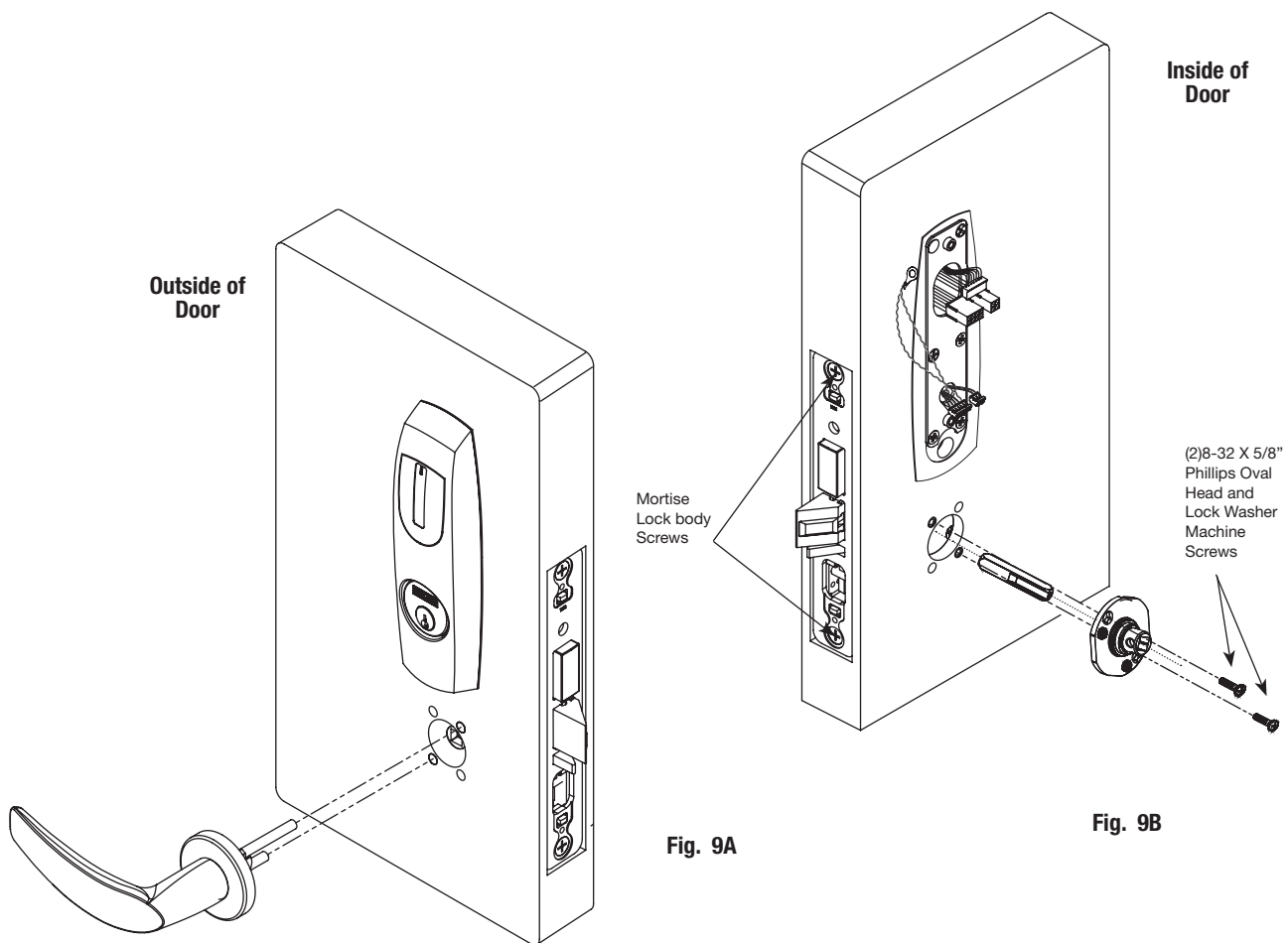

### 9 Installing Controller

Please follow these steps prior to installing inside escutcheon to prevent any damage caused by pinching wires:

1. Feed controller harness earth ground into and around behind rim of large upper hole of the mounting plate (Fig. 10A, B).

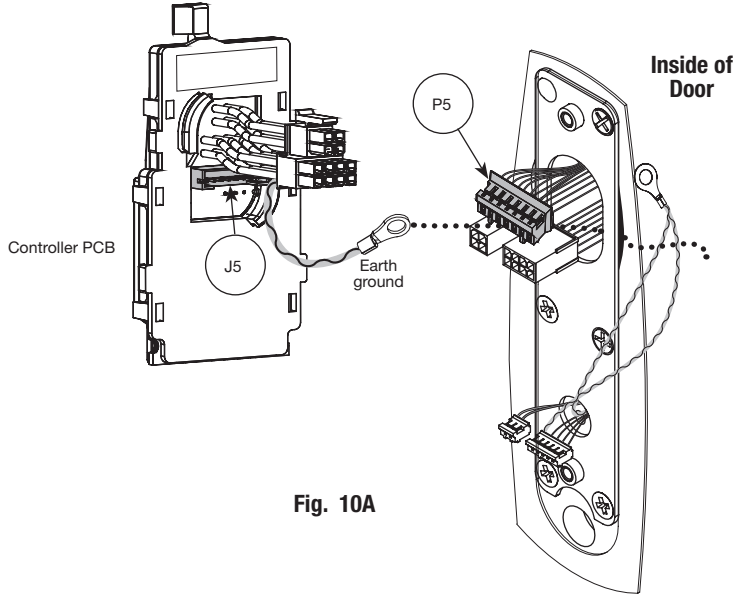

Fig. 10A

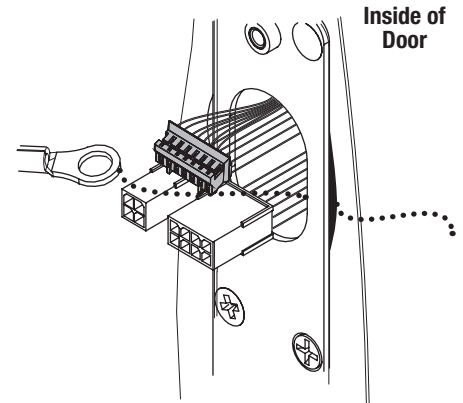

Fig. 10B

#### Connect ElectroLynx®

- a. Connect P5 (7 Pin Connector) from reader board to J5 on interior escutcheon PCB assembly (Fig. 10C).

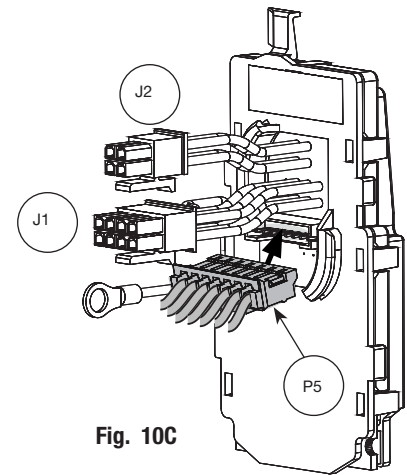

Fig. 10C

- b. Connect ElectroLynx harness (4 and 8-pin) from door harness to ElectroLynx harness on interior PCB assembly (Fig. 10A, D).

NOTES: Neatly fold the wires into the remaining space to prevent pinching wires when mounting escutcheon.

Do not tuck extra mortise lock body wires back inside the lock body cylinder hole.

Connectors go on only one way.

Do not offset connector and be sure they are completely seated.

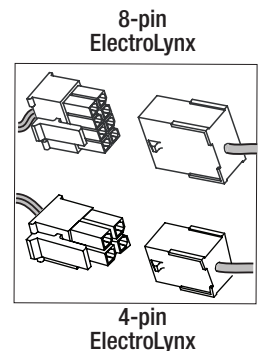

Fig. 10D

PCB Layout - Wire Assignments - ElectroLynx Assembly (Molex)							
J2				J1			
1-Violet Lock Neg	3-Pink	1- Black	3-White	5-Orange	7-Brown		
Actuator (+)	DPS (NC)	PWR NEG	DATA 1	RX (NO/NC)	EGND		
Solenoid (-)							
2-Gray Lock Pos	4-Tan	2-Red	4-Green	6-Blue	8-Yellow		
Actuator (+)	DPS (COM)	PWR POS	DATA 0	RX (COM)	LED		
Solenoid (-)							

# Harmony Series H2 Mortise Lock

## Install Controller

Once wires are arranged, position controller at a rotated angle against the door, under earth ground wire.

- Press piece against door while turning clockwise (Fig. 11A).
- Twist into place, perpendicular with door (Fig. 11B).
- Position two-wire green/yellow ground wire ring terminal (from lock body) over hole for top left screw (Fig. 11B, C).
- Position green/yellow reader harness earth ground on top of two-wire ground ring and thread both with (1) 8-32 x 3/8" Phillips flat head undercut combo screw (Fig. 11C, D).

**IMPORTANT:** Note orientation of ground ring terminals in Fig. 11B-D.

- Tighten securely.

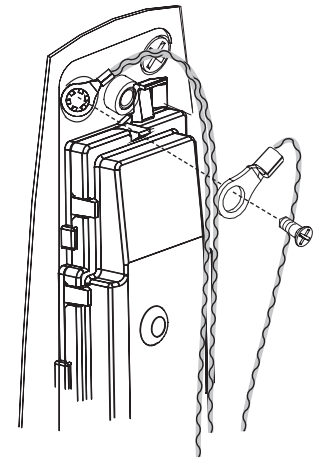

Fig. 11B

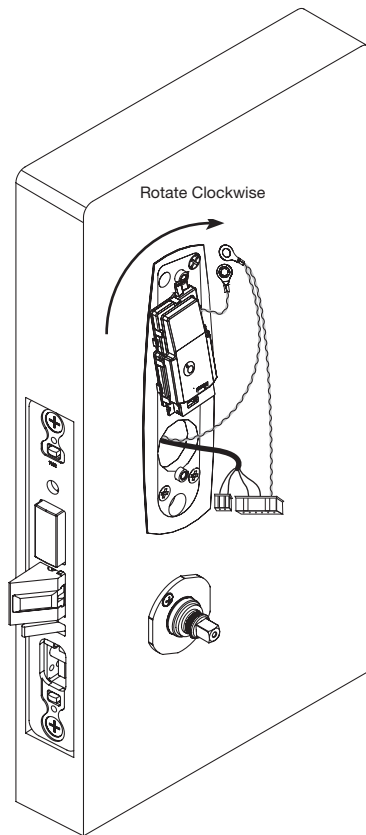

Fig. 11A

Inside of Door

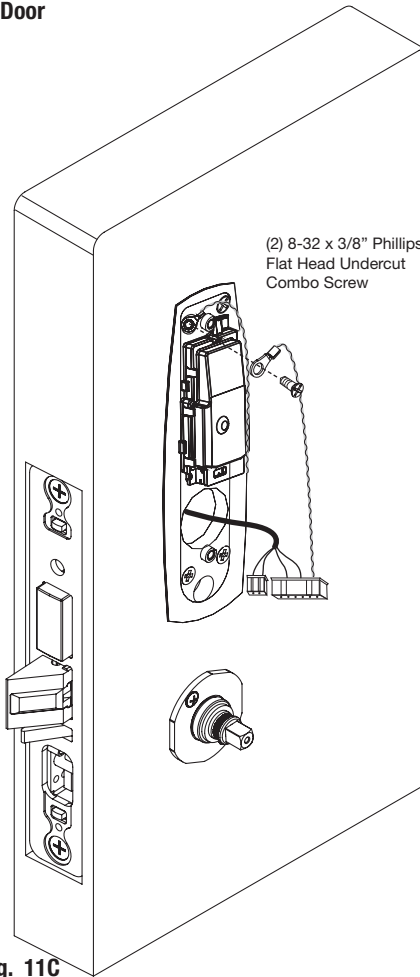

Fig. 11C

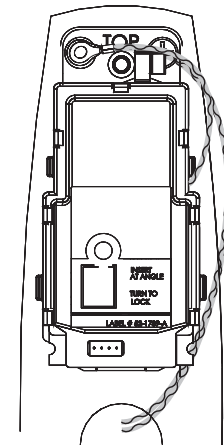
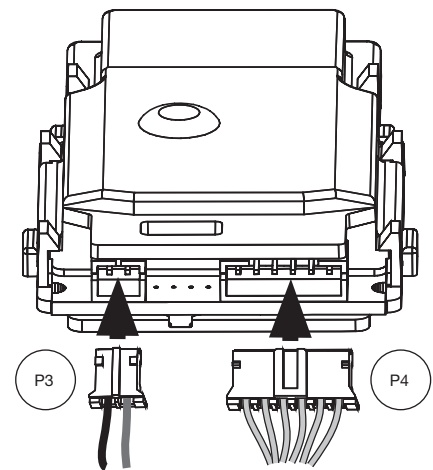

Fig. 11D

## 12 Connector Attachment (Exterior PCB Assembly)

1. Connect P3 (2-pin connector) from lock body to J3 on module (Fig. 12).
2. Connect P4 (6-pin connector) from lock body to J4 on module (Fig. 12).



## 13 Install Inside Escutcheon Assembly

1. Tighten the inside escutcheon securely to the mounting plate with the Phillips flat head machine screws provided.  
Use the 8-32 x 5/8" for the top of the escutcheon and the 8-32 x 1/4" screws for the bottom of the escutcheon located under the turn lever (Fig. 13).

NOTE: The inside gasket (not shown) must be used when installing Harmony in an outdoor application (refer to previous Step 6).

2. Be sure the turn assembly is functional and the deadbolt functions properly.

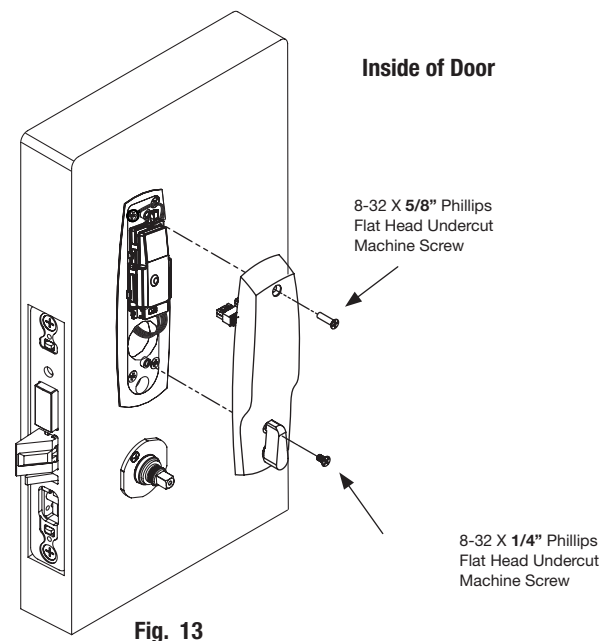



### 14 Inside Rose and Inside Lever Assembly Instructions

1. Rotate the inside rose - first counter clock wise to seat the threads and then, clockwise to securely tighten.
2. Slide lever handle onto spindle until fully seated. Be sure handle is horizontal and facing the hinge side of the door. Push lever onto spindle so minimum gap is visible.
3. Tighten the set screw securely with a 1/8" hex wrench.
4. Before closing the door, test that lever is functional and ensure smooth operation of the latchbolt and deadbolt.

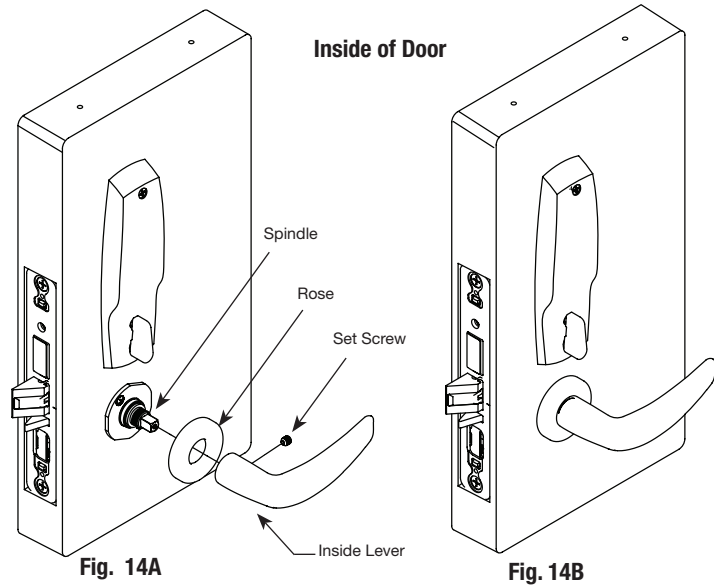

### 15 Attach Front Plate

1. Attach front plate with (2) 8-32x1/4" flat head screws and tighten securely.

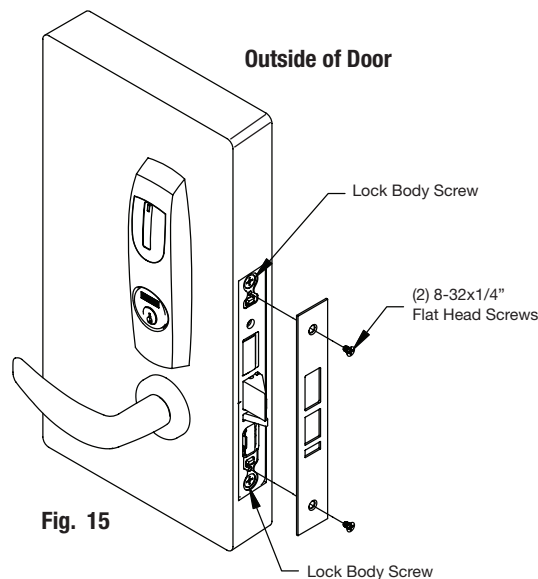

## 9 Mechanical Operational Check

For 82280-82283 & 82270-82273 Function mortise locks with cylinders:

1. Insert key into cylinder and rotate: There should be no friction against lock case, wire harness or any other obstructions.
2. The key will retract the latch: Key should rotate freely.
3. When the deadbolt is thrown: Ensure that the key retracts both the deadbolt and the latch.
4. Inside lever: When used, ensure it retracts both the latch and deadbolt (if provided).
5. Close door: Ensure latch and deadbolt fully extend and do not bind.

## 10 Electrical Operational Check

Note: Once electrical wiring has been successfully completed according to proper application, follow the following steps:

1. Turn power ON.
2. Verify LED located on reader is ON (Red or Green depending on reader configuration (See reader LED Configuration).
3. Present proximity credential and verify LED and sounder activity.
4. Verify valid card read at EAC panel.
5. Verify system operation functions; i.e., present valid Prox credential to reader and unlock door.

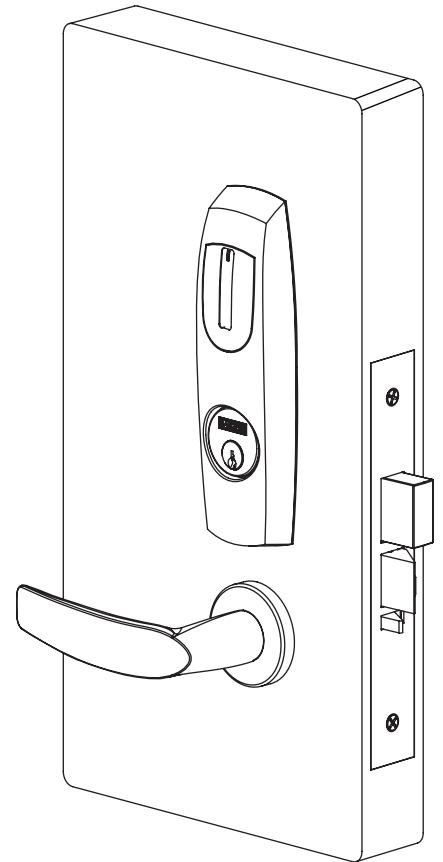

### Wiegand Test Unit

The ASSA ABLOY Wiegand Test Unit verifies your installation in the field. The test unit checks for proper wiring, card reader data integrity, lock functionality including lock/unlock, door position status, and request-to-exit (REX) status.

In addition, this tool provides product demonstration abilities to highlight the product's features and capabilities.

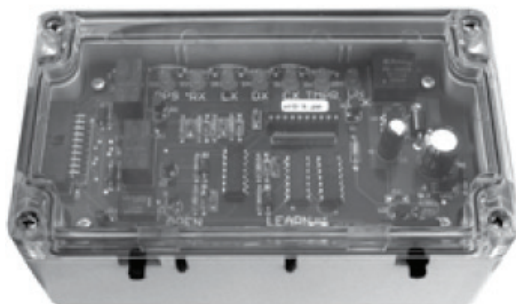

Feature	WT1	WT2
12 or 24VDC solenoid lock voltage adjustable	X	X
Operates as Fail Safe or Fail Secure	X	X
"Learn" mode allows testing of specific cards without programming at the panel level	X	X
Card reader data integrity is validated at test unit	X	X
Works with SE LP10	X	X
Displays detailed Wiegand data, including hexadecimal string and total bits received		X
Displays measured end-of-line resistor values (if applicable)		X



# SARGENT®

## ASSA ABLOY

SARGENT Manufacturing  
100 Sargent Drive  
New Haven, CT 06511 USA  
800-727-5477 • [www.sargentlock.com](http://www.sargentlock.com)

*Founded in the early 1800s, SARGENT® is a market leader in locksets, cylinders, door closers, exit devices, electro-mechanical products and access control systems for new construction, renovation, and replacement applications. The company's customer base includes commercial construction, institutional, and industrial markets.*

*Copyright © 2017, Sargent Manufacturing Company, an ASSA ABLOY Group company. All rights reserved. Reproduction in whole or in part without the express written permission of Sargent Manufacturing Company is prohibited.*

*Sargent Manufacturing Company (New Haven, CT), 2017. Patent pending and/or patent - [www.assaabloyds.com/patents](http://www.assaabloyds.com/patents). HID, iCLASS, and Edge are trademarks or registered trademarks of HID Global Corporation.*

*ASSA ABLOY is the global leader in door opening solutions, dedicated to satisfying end-user needs for security, safety and convenience.*

A8027G-06/17