



Excellence in Compliance Testing

Certification Exhibit

**FCC ID: U4A-SCYICLS1
IC: 6982A-SCYICLS1**

**FCC Rule Part: 15.247 / 15.225
IC Radio Standards Specification: RSS-210**

ACS Project Number: 10-0345

Manufacturer: Assa Abloy
Model: N2-IA/IK

Manual

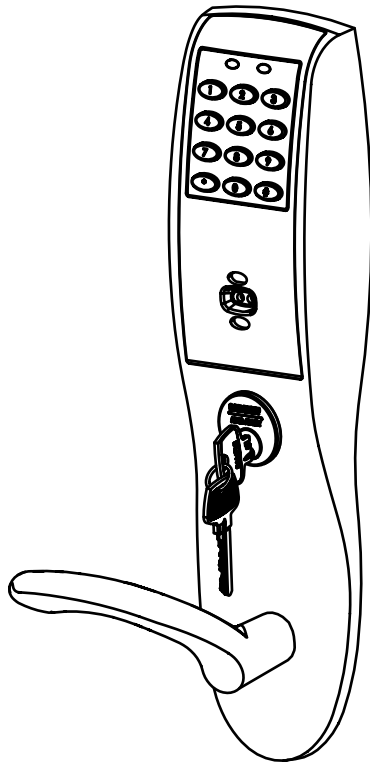

**Profile Series
v.N2 with
Aperio™
Technology**

**Mortise Lock
Installation Instructions**

A8078A

04/11

Table of Contents

1	Warning	2
2	General Description	3
3	Specifications	3
4	System Overview	3
5	Parts Breakdown	4
6	Lock Installation	6
7	Operational Check	14
8	Lock LED Indications	15

1 Warning

Warning: Changes or modifications to this device not expressly approved by ASSA ABLOY could void the user's authority to operate the equipment.

FCC:

This equipment has been tested and found to comply with the limits for a Class B digital device, pursuant to Part 15 of the FCC Rules. These limits are designed to provide reasonable protection against harmful interference in a residential installation. This equipment generates, uses, and can radiate radio frequency energy and, if not installed and used in accordance with the instructions, may cause harmful interference to radio communications. However, there is no guarantee that interference will not occur in a particular installation. If this equipment does cause harmful interference to radio or television reception, which can be determined by turning the equipment off and on, the user is encouraged to try to correct the interference by one or more of the following measures:

- Reorient or relocate the receiving antenna.
- Increase the separation between the equipment and receiver.
- Connect the equipment into an outlet on a circuit different from that to which the receiver is Connected.
- Consult the dealer or an experienced radio/TV technician for help.

Industry Canada:

This Class B digital apparatus meets all requirements of the Canadian Interference Causing Equipment Regulations. Operation is subject to the following two conditions: (1) this device may not cause harmful interference, and (2) this device must accept any interference received, including interference that may cause undesired operation.

Cet appareillage numérique de la classe B répond à toutes les exigences de l'interférence canadienne causant des règlements d'équipement. L'opération est sujette aux deux conditions suivantes: (1) ce dispositif peut ne pas causer l'interférence nocive, et (2) ce dispositif doit accepter n'importe quelle interférence reçue, y compris l'interférence qui peut causer l'opération peu désirée.

"This equipment complies with FCC radiation exposure limits set forth for an uncontrolled environment. This equipment should be installed and operated with minimum distance 20cm between the radiator and your body. This transmitter must not be co-located or operating in conjunction with any other antenna or transmitter."

Under Industry Canada regulations, this radio transmitter may only operate using an antenna of a type and maximum (or lesser) gain approved for the transmitter by Industry Canada. To reduce potential radio interference to other users, the antenna type and its gain should be so chosen that the equivalent isotropically radiated power (e.i.r.p.) is not more than that necessary for successful communication.

2 General Description

The SARGENT® Profile Series v.N2 lock with Aperio™ Technology makes it easy and cost-effective to bring access control to additional doors. It uses local wireless communication between the lock and an Aperio hub to connect to an access control system, eliminating the greatest cost and inconvenience of traditional access control – the wiring at the door. The Profile Series v.N2 includes HID® iCLASS® 13.56 MHz smart card technology, and all technology features are supported by the physical security of SARGENT ANSI/BHMA Grade 1 hardware.

This product is operated by six (6) “AA” alkaline batteries. SARGENT mortise locks are designed with quality components to provide high security, performance and durability.

The Aperio mortise lock may be used for both indoor and outdoor applications. A weather-protective gasket is recommended for outdoor applications.

3 Specifications

Lock

- IEEE 802.15.4 UHF interface
- iCLASS technology
- AES 128 bit encryption

iCLASS Card Requirements

- Supports HID 13.56 MHz iCLASS contactless credentials (full authentication, all formats)
- ISO14443 standard memory types

4 System Overview

When a user presents a supported credential to the lock, the Aperio system is designed to send the credential wirelessly to the Aperio Hub. The Aperio Hub (wired through RS-485 or Wiegand) then communicates with an EAC (Electronic Access Control) system. The EAC system provides the access decision to the Communication Hub where access to the lock is either granted or denied.

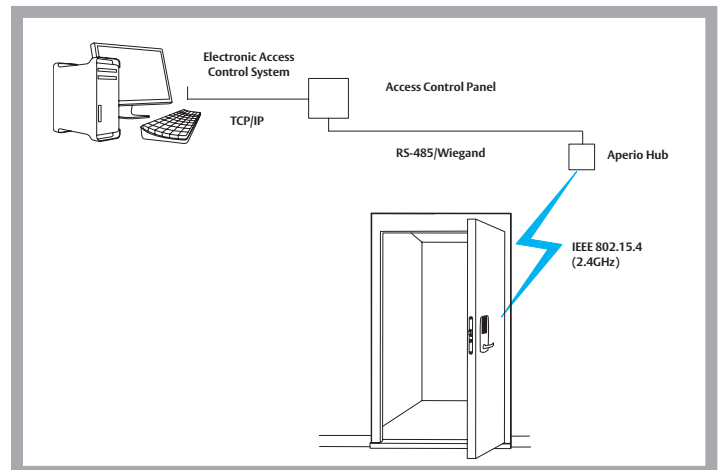

To comply with “Fire Listed” doors, the batteries must be replaced with alkaline batteries only.

Warning: SARGENT Mfg. Co. Profile Series v.N2 locksets utilizing a door position switch (DPS) are not rated for, or intended for use in life safety applications.

5 Parts Breakdown

13.56 MHz iCLASS

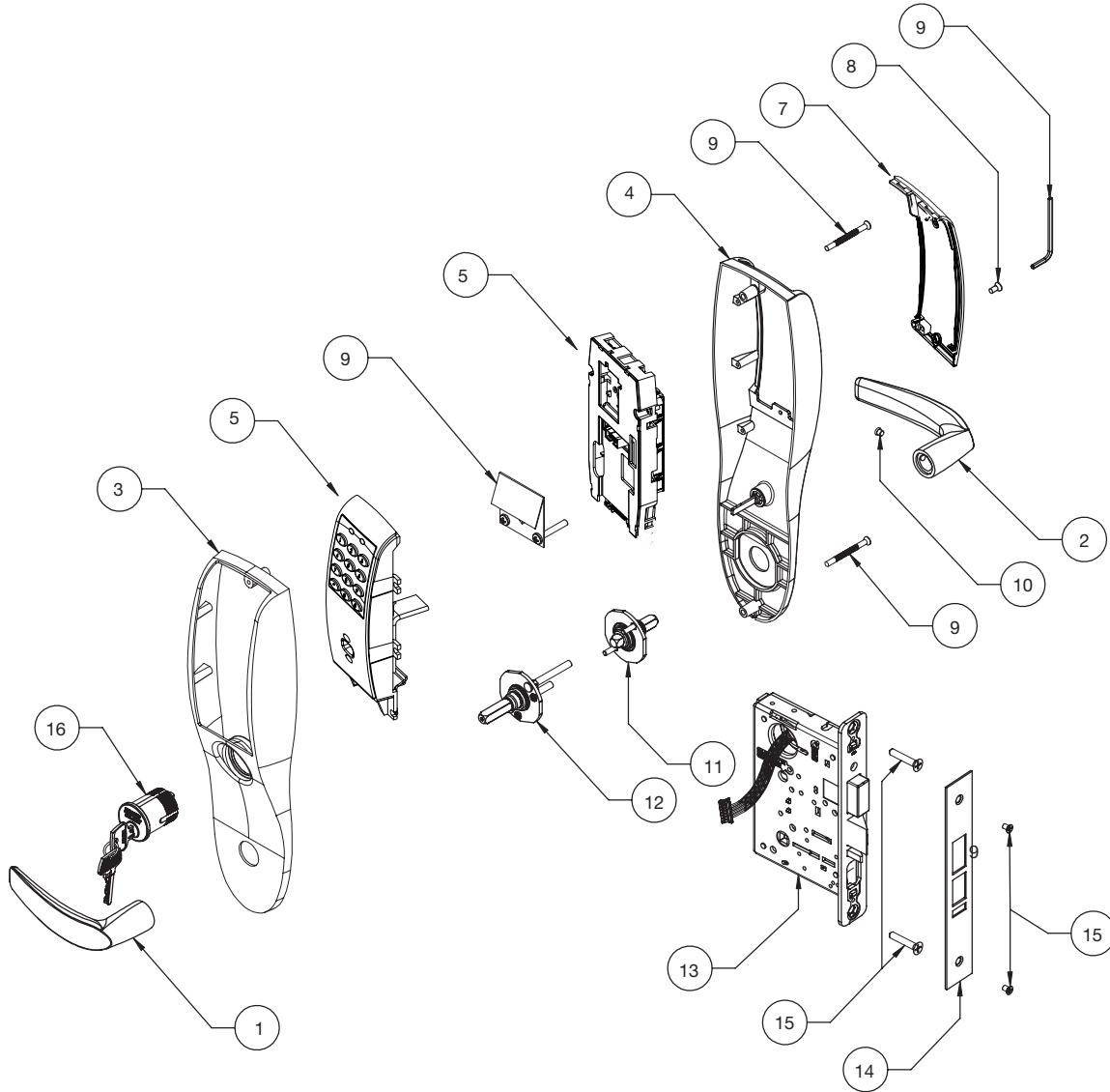

Copyright © 2011, Sargent Manufacturing Company, an ASSA ABLOY Group company. All rights reserved. Reproductions in whole or in part without express written permission of Sargent Manufacturing Company is prohibited.

Parts Breakdown 13.56 MHz iCLASS (Continued)

ITEM	PART NO.	DESCRIPTION	QTY.
1	Outside Lever	Reference 8200 Catalog for available levers	1
2	Inside Lever	Reference 8200 Catalog for available levers	1
3	82-0495	O/S Escutcheon only with Cylinder	1
	82-0493	O/S Escutcheon only without Cylinder	1
4	82-0492	Inside Escutcheon only without Thumb Turn	1
	82-0494	Inside Escutcheon only with Thumb Turn	1
5	52-5291	Aperio Electronic Replacement Pack, 13.56 MHz iCLASS	1
7	52-4340	Battery Cover Assembly	1
8	01-1212	Security Screw	1
9	52-2427	Profile Screw Pack - Specify Finish (Includes: Fire Stop Plate, Trim Mounting Screws, Security Allen Wrench)	1
10	Consult Factory	Lever Handle Screw (Depends on Lever Style)	1
11	Consult Factory	Inside Adapter Assembly (Depends on Lever Style)	1
12	Consult Factory	Outside Adapter Assembly (Depends On Lever Style)	1
13	N2-82276-hand-finish	Lockbody with Dead Bolt with Cylinder	1
	N2-82277-hand-finish	Lockbody with Dead Bolt without Cylinder	
	N2-82278-hand-finish	Lockbody with Dead Bolt with Cylinder	
	N2-82279-hand-finish	Lockbody with Dead Bolt without Cylinder	
14	82-0084	Faceplate with Dead Bolt (shown)	1
	82-0081	Faceplate without Dead Bolt	1
15	77-4336	Mortise Screw Pack - Specify Finish (Includes: Wood and Metal Lock body Screws, Faceplate Screws, and Strike Screws)	1
16	Consult Factory	#43 Mortise Cylinder	1

Copyright © 2011, Sargent Manufacturing Company, an ASSA ABLOY Group company. All rights reserved. Reproductions in whole or in part without express written permission of Sargent Manufacturing Company is prohibited.

04/08/11

6 Lock Installation

1 Prepare Door

A. Verify Hand and Bevel of Door

Stand on outside of locked door when determining door hand.

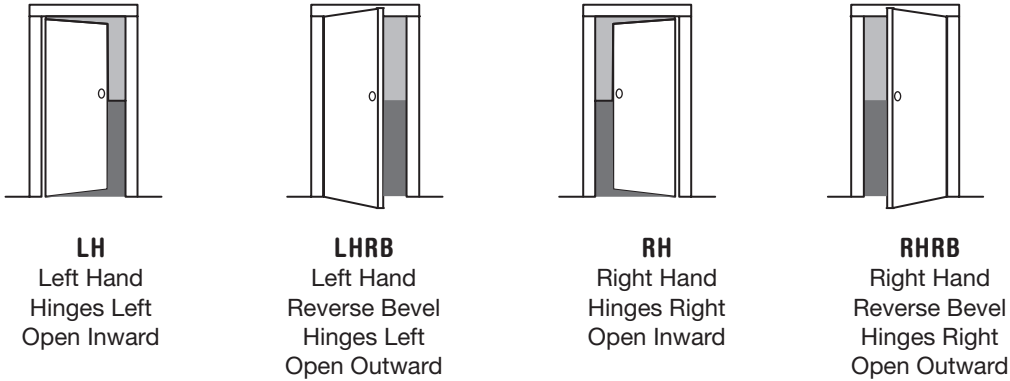

Fig. 1A

B. Door Preparation

Prior to installation, all holes must be free of burrs, debris and sharp edges.

Prepare door according to appropriate template (see website www.intelligentopenings.com):

- Wood door: A7457 (ships with product)
- Metal door: Template 4533

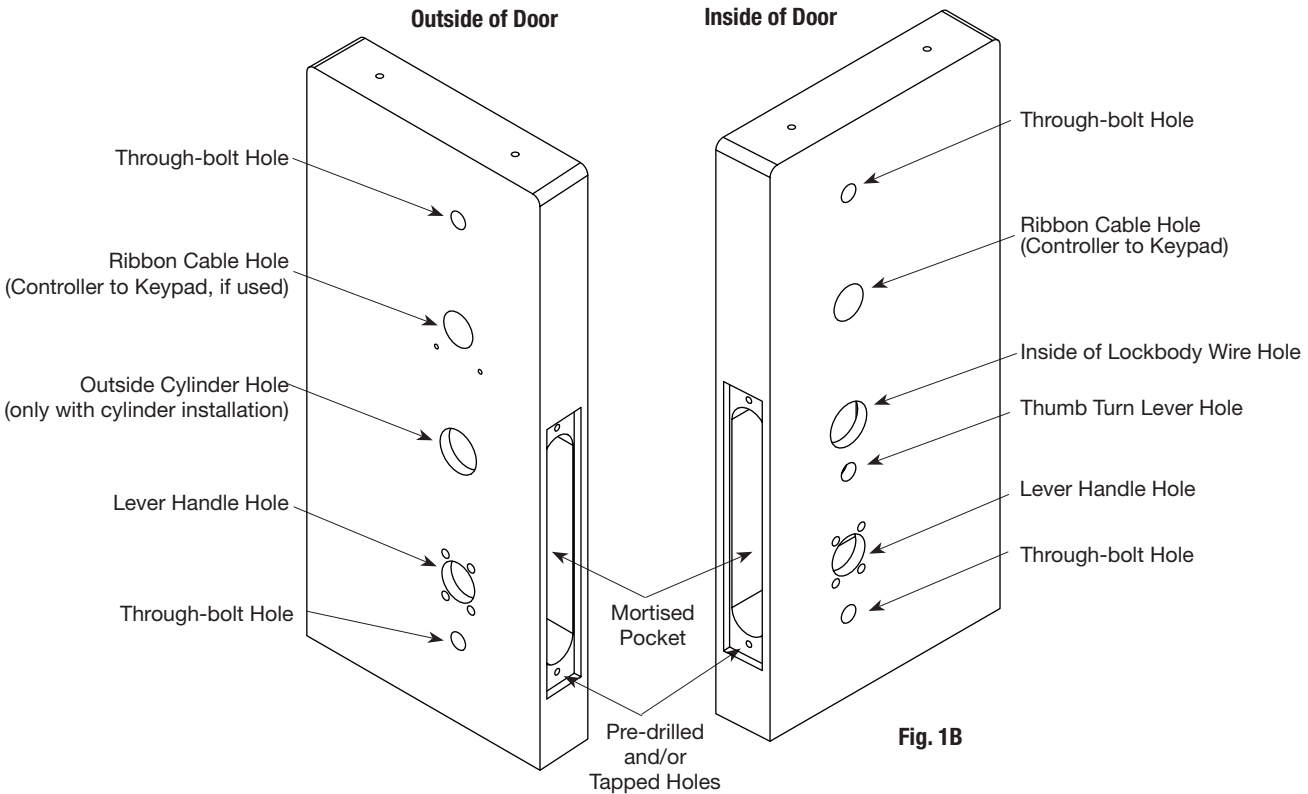

Fig. 1B

Copyright © 2011, Sargent Manufacturing Company, an ASSA ABLOY Group company. All rights reserved. Reproductions in whole or in part without express written permission of Sargent Manufacturing Company is prohibited.

2 How to Change Hand of Lock body

A. Reverse Lock Hand

Red surface of locking piece must face the outside/locked side of door. To rotate locking piece (Fig. 2A):

1. Position lock body with red surface of locking piece visible.
2. Insert blade type screwdriver into locking piece slot to rotate locking piece toward back of lock body.
3. Rotate the locking piece 180° until RED surface is on opposite side.

Note: Red indicates locked side (outside).
Wire harness MUST exit through the inside/non-cylinder side of the lockbody.

B. Retaining Ring

Make sure the plastic retaining ring is seated correctly (Fig. 2B):

1. The wires and the plastic retaining ring must be located on the non-cylinder side.
2. Orient the modified retaining ring so that the word **Bottom** is located at the upper portion of the cylinder hole.
3. Route the wires from the top of the cylinder hole into the slot on the top of the plastic retaining ring, NOT through the retaining ring.

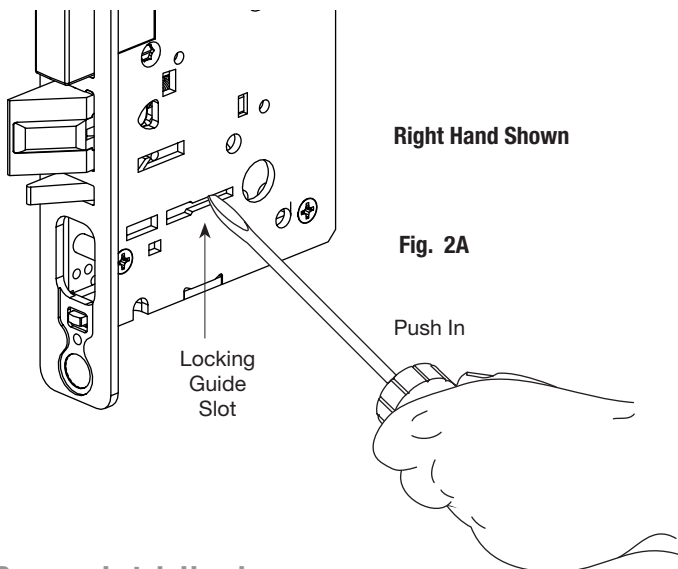
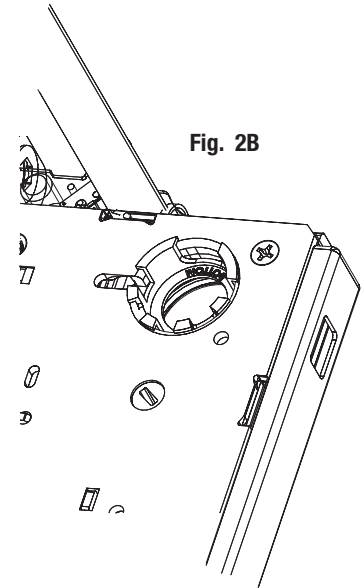

C. Reverse Latch Hand

Beveled surface of latchbolt must face strike.

The deadlatch is self adjusting.

To change the hand of the latchbolt:

1. Insert the blade of a slotted screwdriver approximately 1/4" into the spade shape slot behind latch.
2. Rotate the screwdriver 90° to push latchbolt out until back of bolt clears lock case front.
3. Rotate latchbolt 180° until the latchbolt drops back into the lockbody.

Note: Latch cannot be unscrewed.

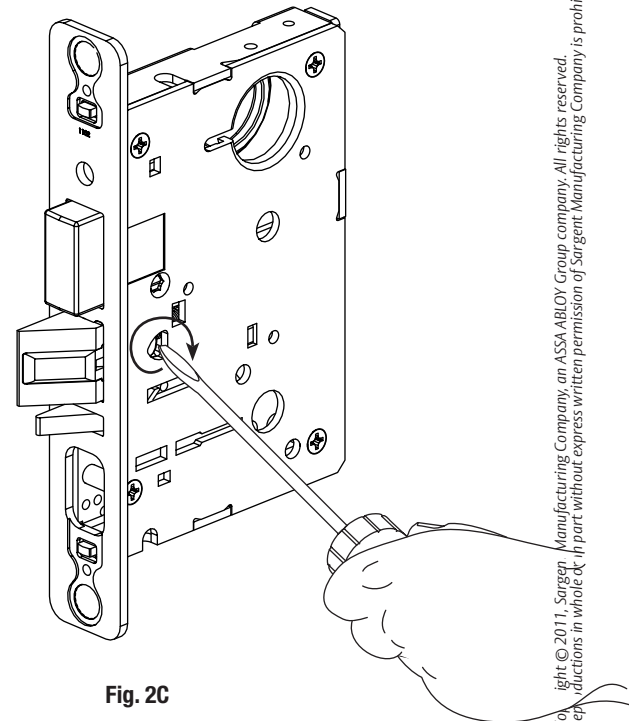

3 Mortise Lock Body DIP Switch Settings

NOTE: The DIP switch RX settings located on the rear of the mortise lockbody must be set prior to lock installation. Failure to follow sticker directions will cause inaccurate RX activity to be reported to the access control panel.

Set DIP switch for appropriate door application by sliding the DIP switch to the side opposite the red surface of the locking slide.

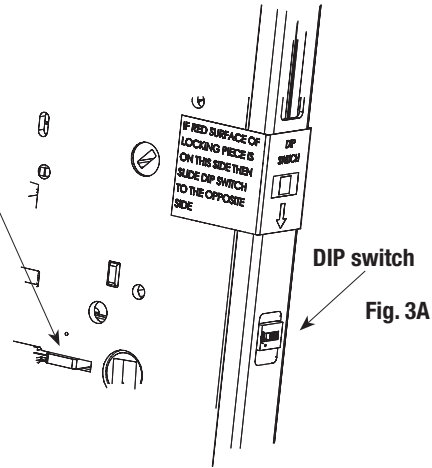

4 Install Lockbody

To install the Lockbody:

1. Feed the wires first through the mortise pocket then feed the wires from the lockbody through the inside door prep for the mortise cutout (Fig. 4A).

Note: Connectors and wires must be fed through the non-cylinder side.

2. The wires from the lockbody exit the inside door prep through the mortise cutout.
3. Loosely secure the lockbody in the door with two #12 x 1-1/4" wood screws or #12-24 x 1/2" machine screws.

Note: Do not completely tighten at this time.

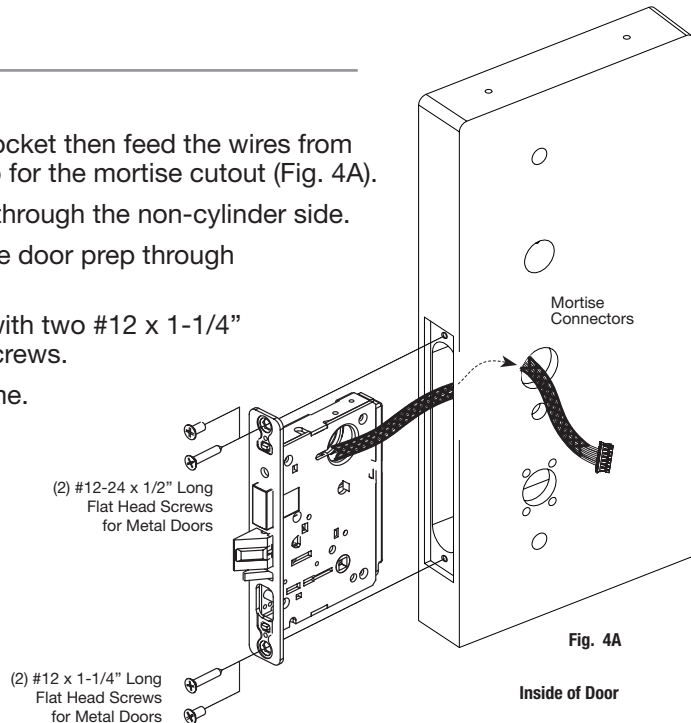

5 Exterior Door Options

A. Fire Stop Plate (P/N 52-0033)

Fire-rated doors require a fire stop plate on the outside of the door (Fig. 5A).

1. Drill (2) 1/8" x 1-1/4" deep holes in the door, if not already present.
Refer to template for fire-stop prep locations.
2. Attach with flap up and out using (2) #8 x 1/2" self-tapping screws for wood and metal doors.

B. Weather Conduit (P/N 52-2847)

Install weather conduit (part number 52-2847) on **NON Fire-Rated** exterior doors only (Fig. 5B).

1. Carefully insert the weather conduit into the ribbon cable hole on the inside of the door.
2. Place the O-ring around the weather conduit on the outside and up against the door (Fig. 5C).

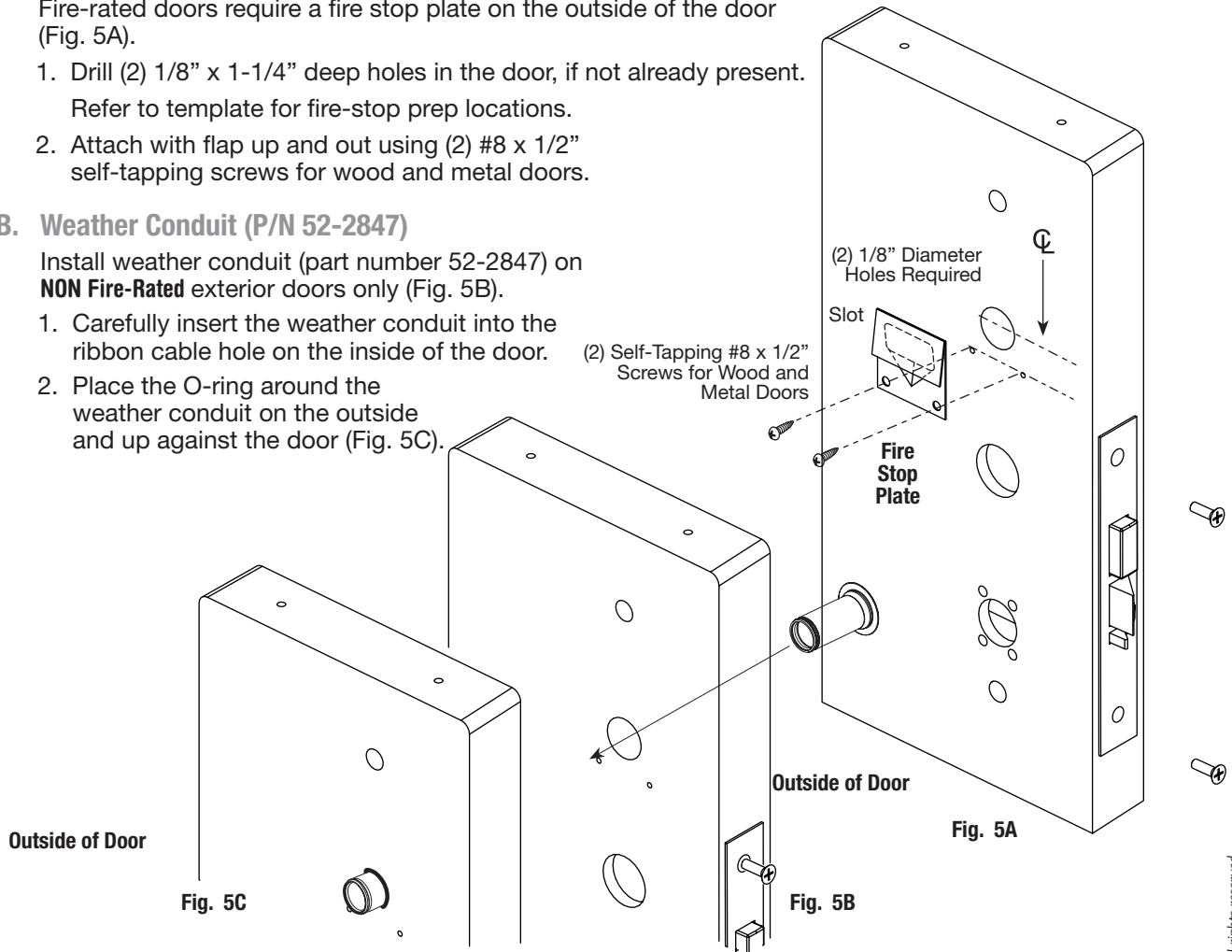

6 Install Gasket (for Exterior Doors)

For exterior applications, use weatherseal gasket between escutcheon and outside door surface.

To apply weatherseal gasket:

1. Carefully remove the backing from the gasket (Fig. 6A).
2. Apply gasket to escutcheon:
 - a. Starting in one place, press the adhesive side of the gasket firmly against the escutcheon.
 - b. Work around the escutcheon, pressing the sticky side of the gasket firmly against the escutcheon edge.
 - c. The gasket should be aligned so that all edges of the escutcheon are covered.

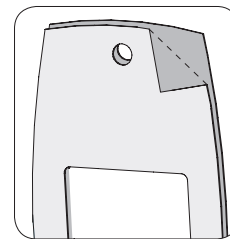

Fig. 6A

7 Install Outside Escutcheon

1. Attach escutcheons to the door after the wires are connected.

Note: The 43 cylinder may be used with or without a gasket.

- 2A. **For fire rated doors:** Feed ribbon cable with connector from outside of door through weatherseal gasket and fire stop plate (Fig. 7A).

Note: Install ribbon cable with cable exiting down.

- 2B. **For non-fire rated doors:** Feed ribbon cable with connector from outside of door through weatherseal gasket (if used) and weather conduit.

Note: Install ribbon cable with cable exiting down.

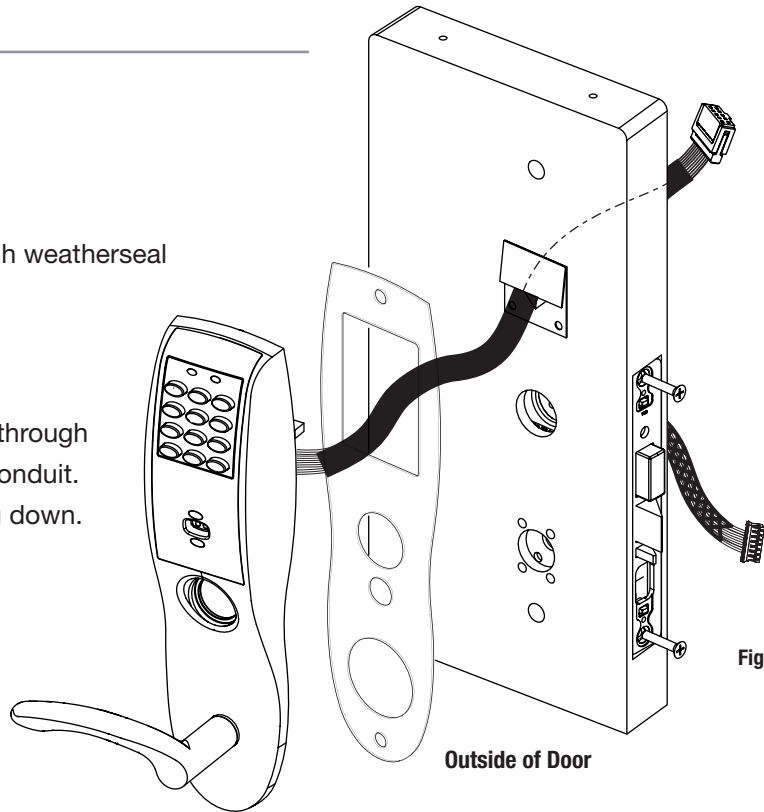

Fig. 6A

8 Install Lock

1. With outside lever horizontal, locate the outside escutcheon on the door, while directing the mounting posts through the door and lock body (Fig.8A).

Make sure the lever spindle is properly engaged in lock.

2. On the inside of the door, insert spindle into the square hole of mortise lock.
3. Slide inside adapter and plate assembly over spindle and loosely secure with 2 through-bolt screws (#8-32 x 5/8”).

Note: For 82276 and 82278, loosely thread cylinder through escutcheon and into the lock body before tightening the lock case screws and escutcheon through bolts.

4. Loosely install the optional cylinder, if present.
5. Fully tighten the lock case screws and escutcheon through bolts.

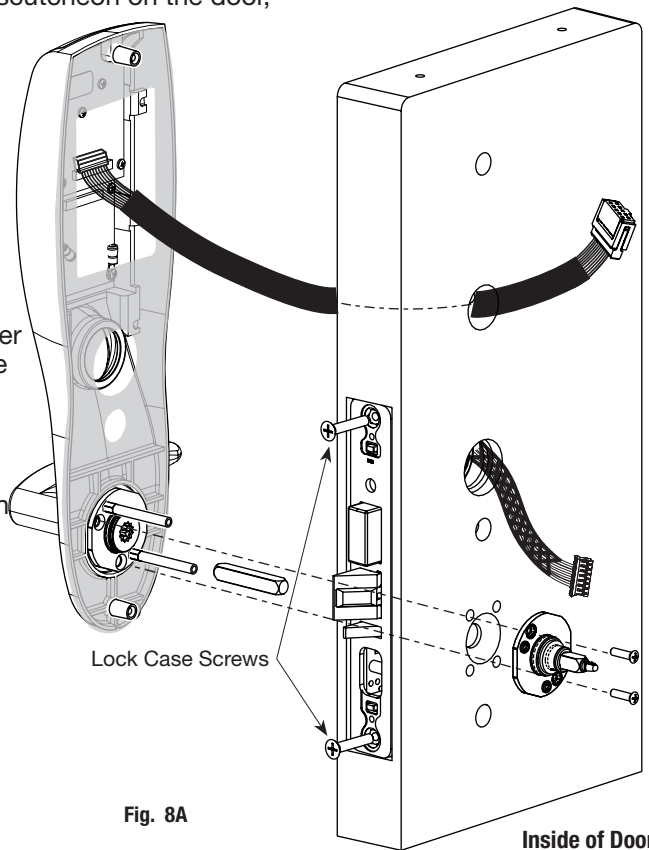

Fig. 8A

9 Inside Escutcheon Connections

Before the controller is attached to the door:

1. Connect the cable from the mortise lock to the bottom of the controller assembly (TB1).
2. Attach the reader assembly ribbon cable into the controller assembly (2).

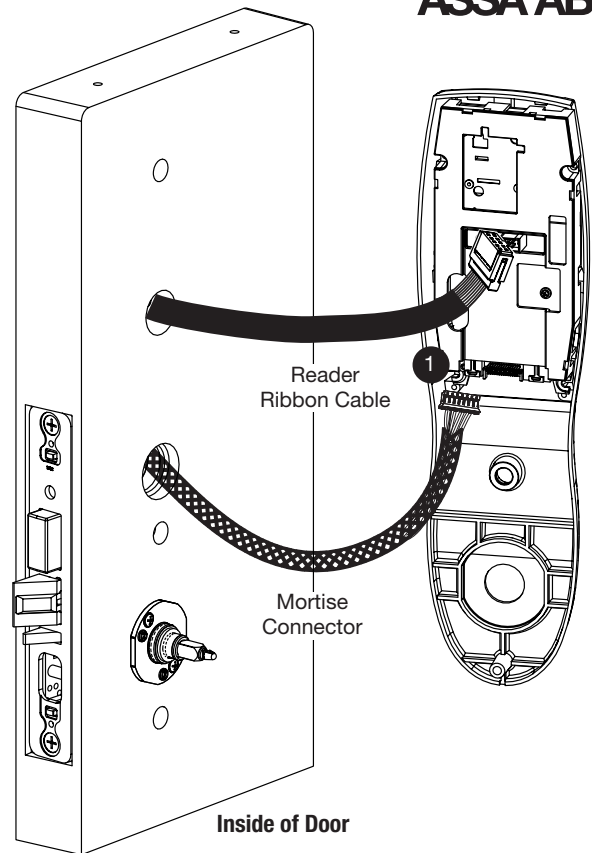

Fig. 9A

10 Install Inside Escutcheon

1. Gently fold the excess ribbon cable into the ribbon cable hole and mortise and wires into the inside of lock body wire hole, being careful not to pinch wires.
2. Insert (2) #8-32 x 1-1/4" screws through inside escutcheon and thread into outside escutcheon. Straighten escutcheons and tighten securely.

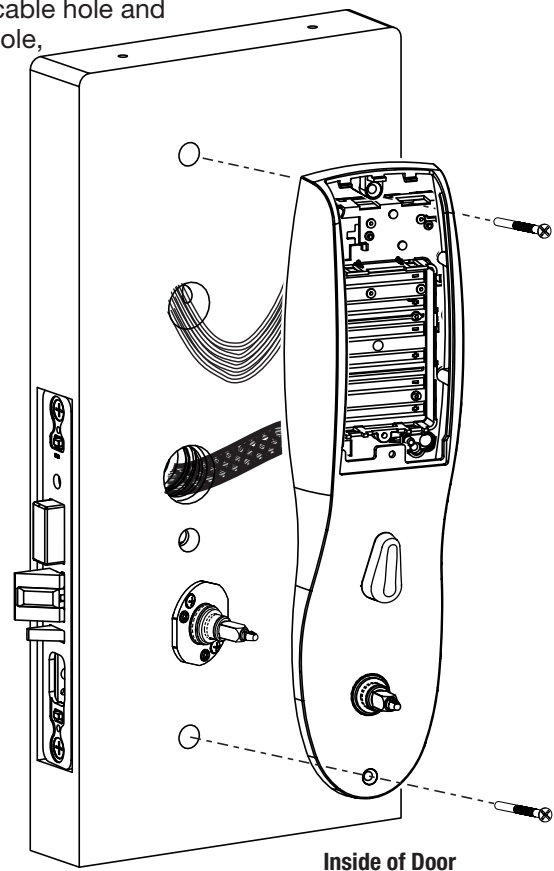

Fig. 10A

Copyright © 2011, Sargent Manufacturing Company, an ASSA ABLOY Group company. All rights reserved. Reproductions in whole or in part without express written permission of Sargent Manufacturing Company is prohibited.

04/08/11

ASSA ABLOY

11 Install Inside Lever

1. Slide lever handle onto spindle until fully seated (Fig. 11A).
2. Tighten the set screw securely with 1/8" hex wrench (Fig. 11B).

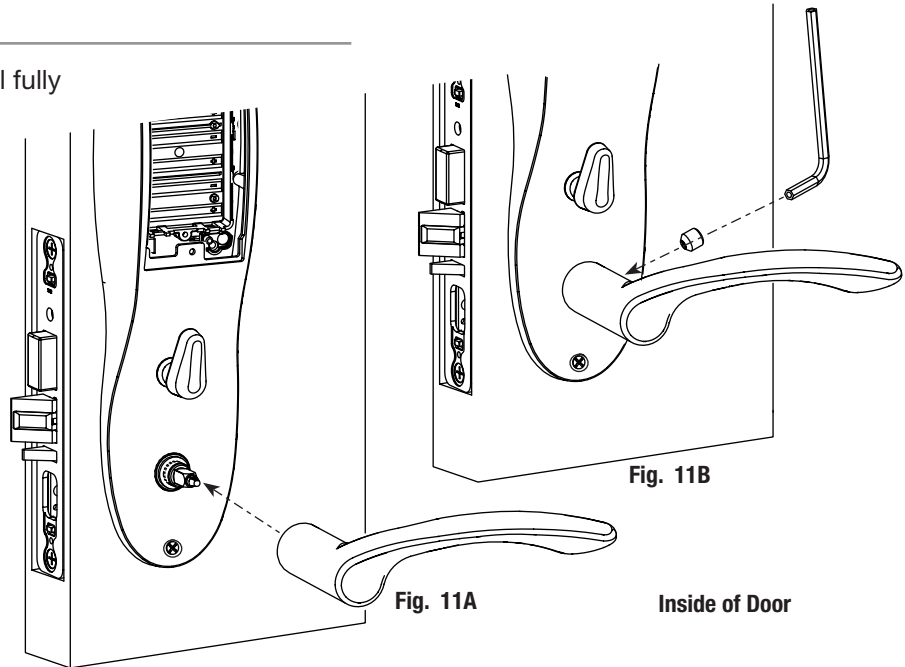

12 Install and Secure Cylinder

1. Slide cylinder through the spring and screw into lockbody, rotating the cylinder clockwise (Fig. 12A). Cylinder should be flush with rosette/collar.

Note: The 43 cylinder may be used when installing this product with or without a gasket.

Note: SARGENT logo must be horizontal and on the top of the cylinder (Fig. 12B).

2. Secure the cylinder by tightening the cylinder clamp screw located above the deadbolt using a #2 Phillips screwdriver (Fig. 12C).

Using the key, test cylinder functions:

- 82278 Function: Key retracts latch.
- 82276 Function: Key retracts latch and projects and retracts deadbolt.

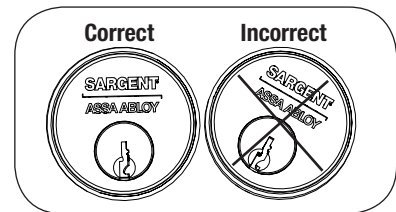
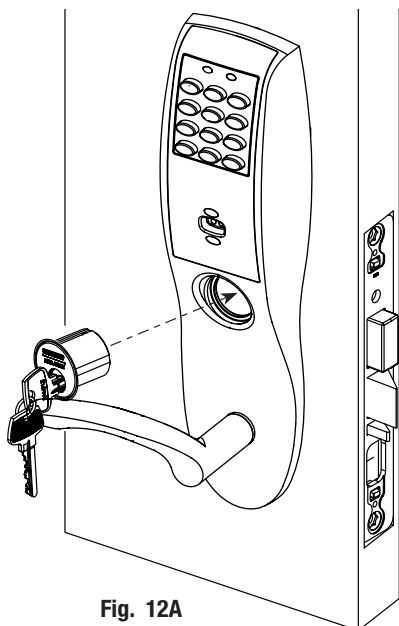
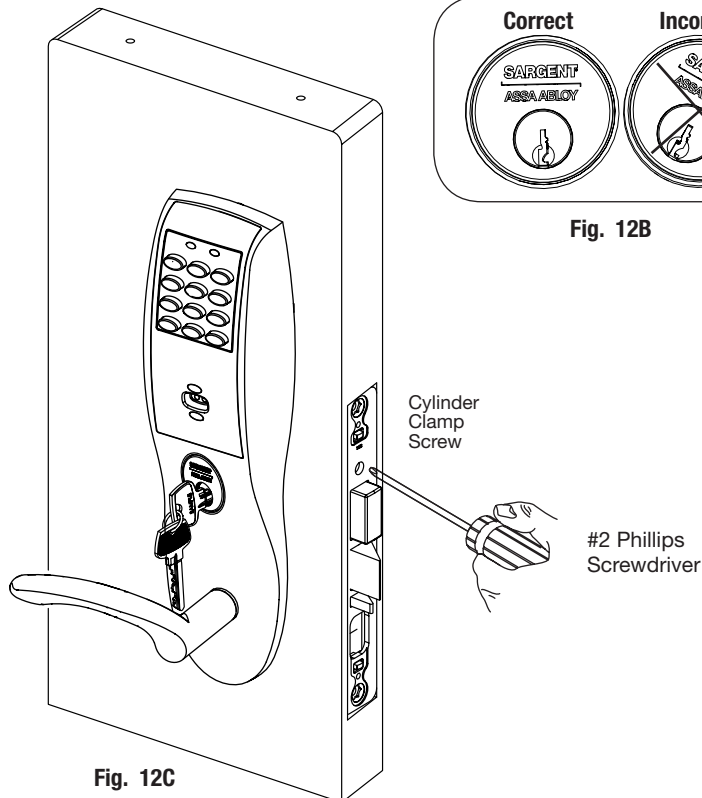

Fig. 12B



Outside of Door



13 Attach Front Plate

Attach front plate with (2) flat head screws.

Outside of Door

Fig. 13A

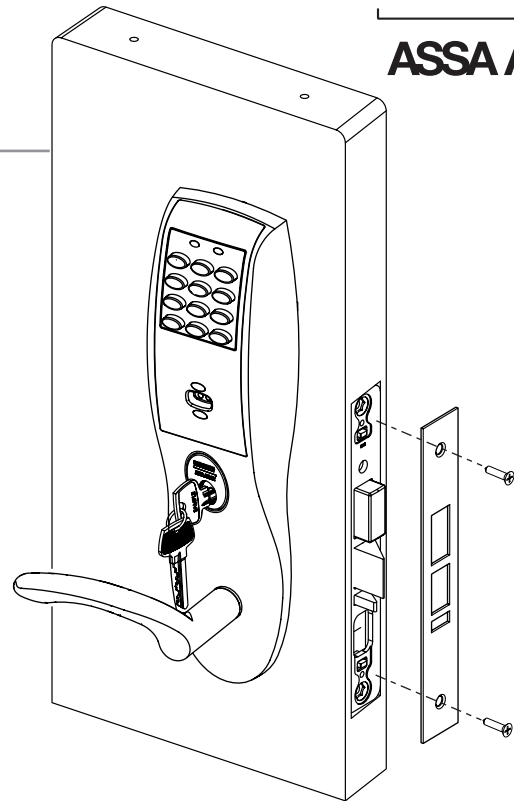

14 install or Replace Batteries

1. To install or replace batteries, first remove the battery cover (if necessary) using the provided security tool (Fig.14A).
2. Unscrew the bottom screw of the battery keeper and remove the battery keeper, being careful not to break the top tabs holding it in place (Fig.14B).
3. Place (6) "AA" alkaline batteries in the compartment, being careful to align polarity properly.
4. Replace battery keeper, being careful to engage tabs on the top to hold it in place (Fig. 14B).
5. Attach battery cover to inside escutcheon, making sure to line up tabs with retaining slots in battery cover (Fig. 14C).
6. Secure with the security screw using tool. (Fig. 14A).

NOTE: Ensure the tamper switch activator does not fall out of the cover during assembly. A tamper event message will be sent to the EAC panel if tamper is enabled.

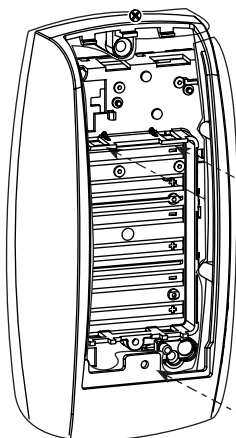

Fig. 14B

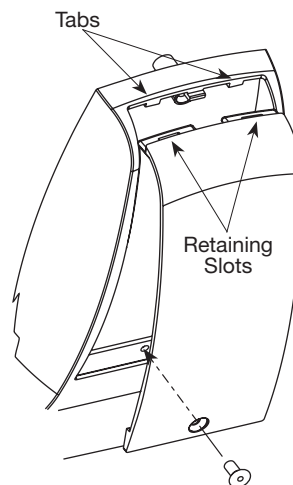

Fig. 14C

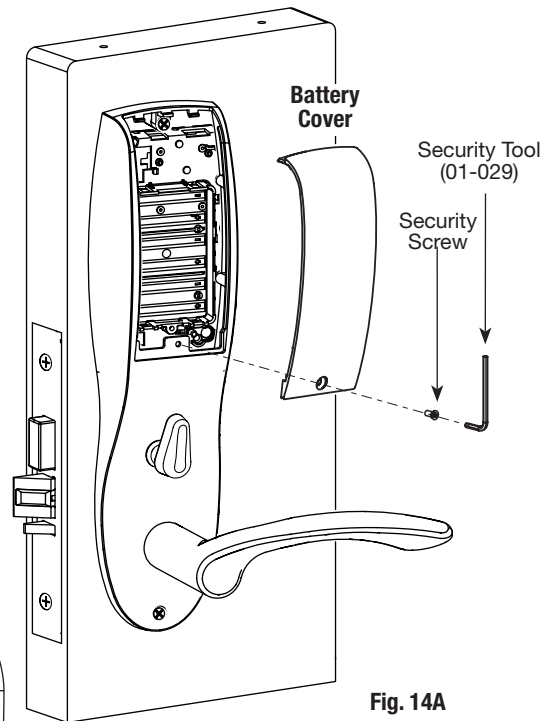

Fig. 14A

Inside of Door

7 Operational Check

For 82276- and 82278-function mortise locks with cylinders:

1. Insert key into cylinder and rotate.

There should be no friction against lock case, wire harness or any other obstructions.

(Refer to **Section -6 Wiring** if harness friction exists).

2. Check that the key retracts the latch:

The key should rotate freely.

3. Throw the deadbolt:

Check that the key retracts both the deadbolt and the latch.

4. Try the inside lever:

Ensure it retracts latch and deadbolt (if provided).

5. Present a valid iCLASS credential to unlock outside lever and retract latch.

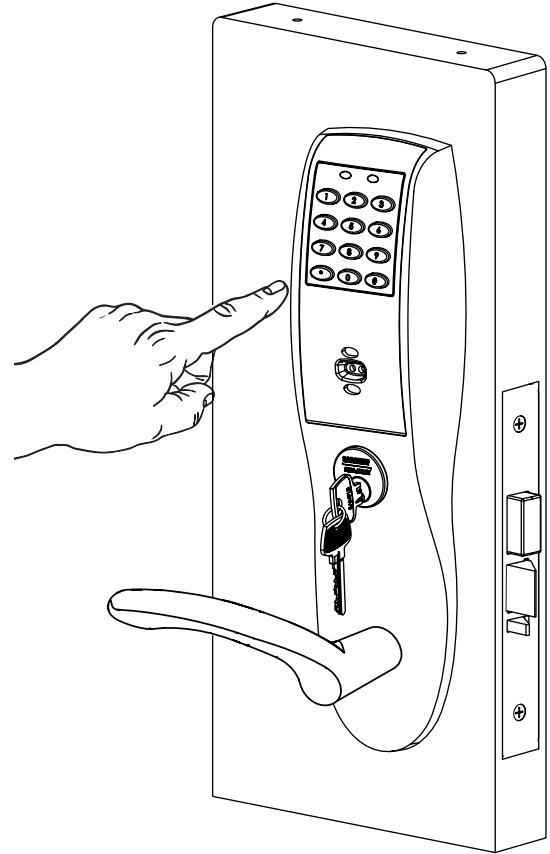

8 Lock LED Indications

1 Lock Normal Operation LED indication

The lock has three LEDs that support an optical scheme with red, yellow and green. The indication scheme is described by the figures below:









Card read (configurable)		One yellow flash (.25 second)
Access granted, EAC offline or online		One green flash (1 second)
Access denied, EAC online		One red flash (1 second)
Access denied, EAC offline		Three red flashes (.5 s each)
Lock mechanism is blocked when closing		Continuous red flashes blocked when closing (.125 seconds every 1 second)
Error in lock, maintenance required		Ten red flashes (.125 s each), maintenance required; repeated if lock can't close
Time to replace the battery		Continuous yellow flashes (.25 seconds every 5 seconds)
Battery reached end of life, lock disabled		Continuous red flashes of life, (.25 seconds every 5 seconds)

Fig. Lock Normal operation LED indication

NOTE: When the lock mechanism is blocked (lock jammed) the knob must be turned to release it. The "Error in lock" indication is also shown instead of the POST flashes if the battery is not accepted as new after a power-on-reset.

2 Lock Maintenance LED Indication

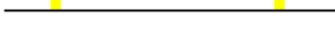
Some special LED indication schemes are used during lock maintenance actions:

Enter configuration mode		Five yellow flashes (.125 s each)
--------------------------	---	-----------------------------------

Fig. Lock maintenance LED indication

3 Lock Self Test LED Indication

After replacing the battery, a Power On Self Test (POST) is performed. The result is indicated using a series of red and green LED flashes as is described by the figure below:

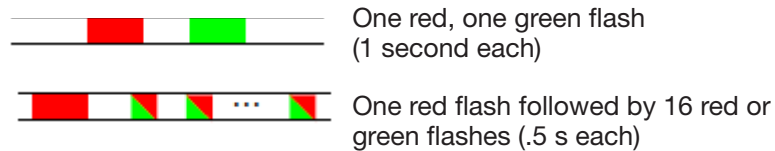

Fig. Lock POST LED indication

The first flash is always red. If the POST fail, the color of the 16 trailing flashes indicate the status of each individual test as described by the following table:

Blink	Meaning if Red	Code in Event Log
2	Main board firmware corrupt	0x0001
3	Override list corrupt	0x0002
4	Production data corrupt	0x0004
5	Security data corrupt	0x0008
6	Configuration data corrupt	0x0010
7	Battery power low	0x0020
8	RFID reader circuit error	0x0040
9	Voltage regulator error	0x0080
10	Card detection circuit error	0x0100
11	Secure area communication error	0x0200
12	Secure area memory corrupt	0x0400
13	Secure area sensor or motor error	0x0800
14	Radio modem communication error	0x1000
15	Radio modem memory corrupt	0x2000
16	Radio modem configuration error	0x4000
17	Radio modem RF circuit error	0x8000

NOTE: If the battery is not accepted as new after a power on reset, no POST is performed. Instead, the 10 quick red flashes used to indicate Error in lock is shown.

SARGENT Manufacturing
 100 Sargent Drive
 New Haven, CT 06511 USA
 800-810-WIRE (9473) • www.sargentlock.com

Founded in the early 1800s, SARGENT® is a market leader in locksets, cylinders, door closers, exit devices, electro-mechanical products and access control systems for new construction, renovation, and replacement applications. The company's customer base includes commercial construction, institutional, and industrial markets.

Copyright © 2011, Sargent Manufacturing Company, an ASSA ABLOY Group company. All rights reserved. Reproduction in whole or in part without the express written permission of Sargent Manufacturing Company is prohibited.

ASSA ABLOY is the global leader in door opening solutions, dedicated to satisfying end-user needs for security, safety and convenience.