



ATID Co.Ltd

ATM2000 USER'S MANUAL

OEM/Integrators Installation Manual

Doek-Jae Lee

2017-01-24

	ATM2000 USER'S MANUAL								
	ATM2000 manual					Company	ATID Co.Ltd		
	Document		Writer	DJ Lee	Date	2017-01-24	Ver.	v0.1	

Contents

- ▶ **Introduction**
- ▶ **System Composition Diagram**
- ▶ **Composition Parts**
- ▶ **Reader Description**
- ▶ **Reader Specification**
- ▶ **Mechanical Dimension**

	ATM2000 USER'S MANUAL								
	ATM2000 manual					Company	ATID Co.Ltd		
	Document		Writer	DJ Lee	Date	2017-01-24	Ver.	v0.1	

▶ Introduction

- ATM2000 is a small RFID reader module designed for the embedded reader market, including the printer, industrial PDA and similar devices. It offers low-cost, high-performance features as well as small size. Also, it supports ISO18000-6C (EPC C1G2) protocol and interfaces with main system through UART.

- **Subjects of application**

PDA type RFID Reader

RFID Printers / Tag Encoders



USB Readers

Smart-Shelves

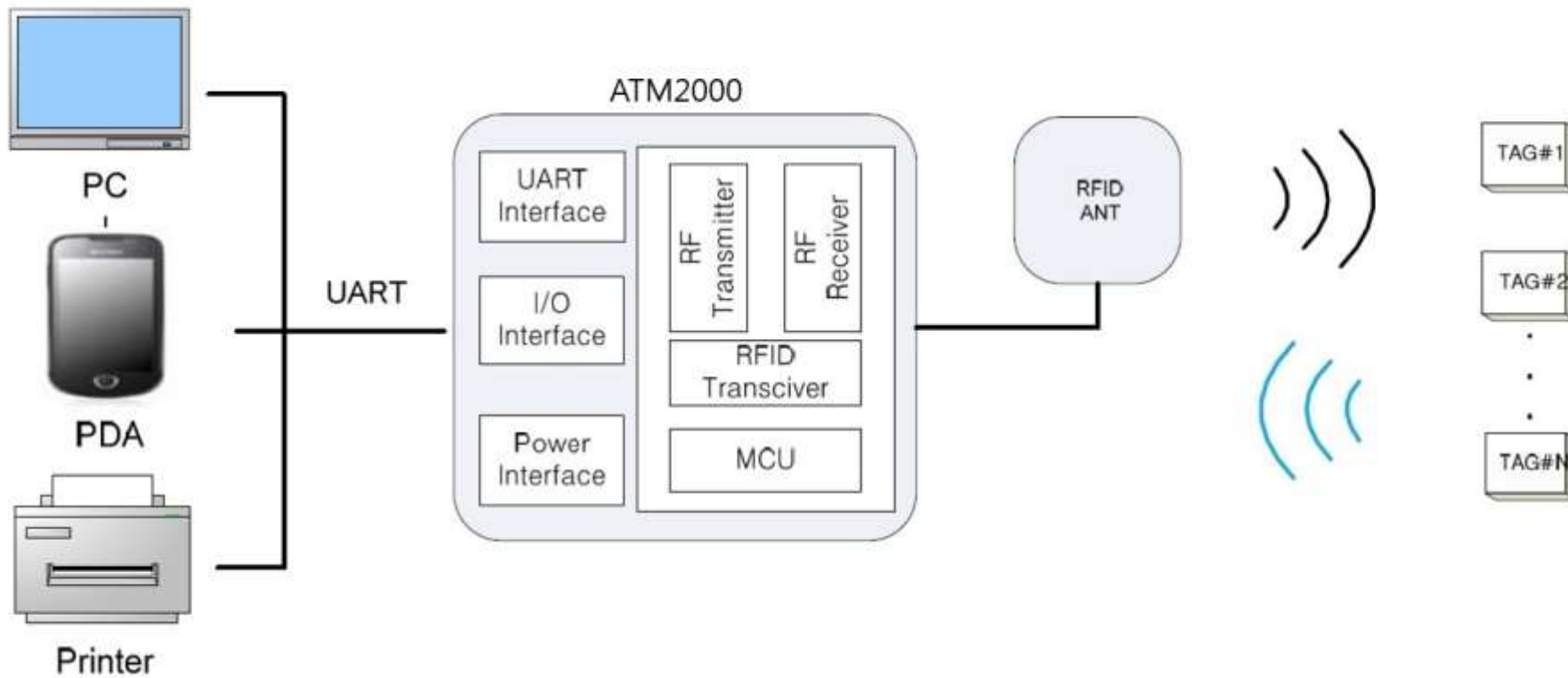
▶ System Composition Diagram

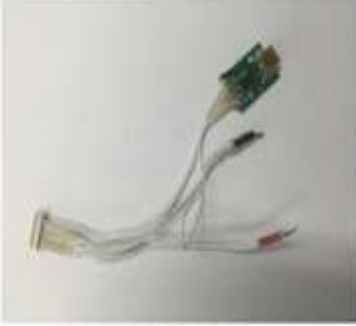

► **Composition Parts**

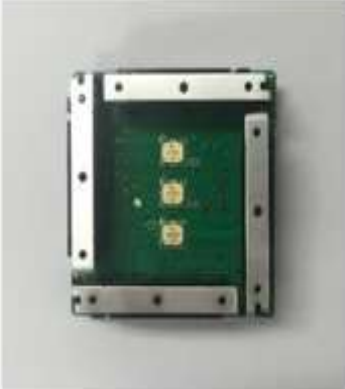
<p>RFID Reader Module</p>		<p>UART to USB Convertor</p>		<p>Linear ANT.</p>	
<p>Interface Cable</p>		<p>Circular ANT.</p>			

▶ Reader Description

Connector & Port of Module

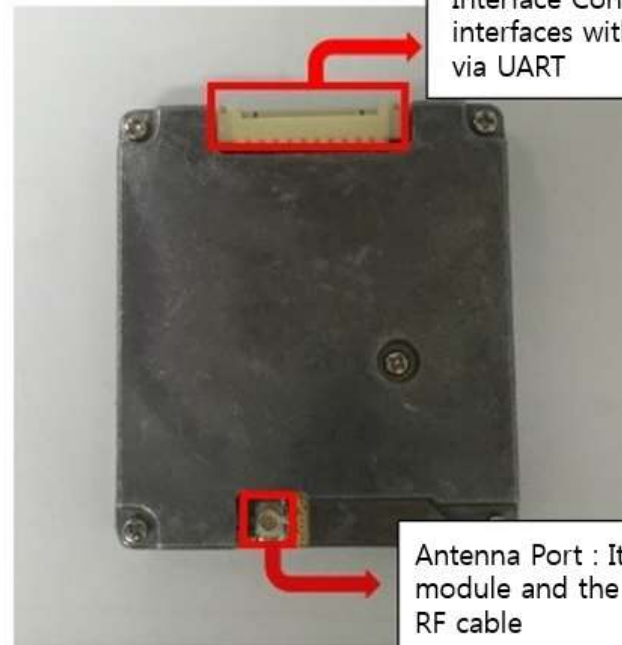

Interface Connector : It supplies power and interfaces with the main system(PC, PDA, etc.) via UART

Antenna Port : It connects the module and the antenna using RF cable

Interface Pin-Map

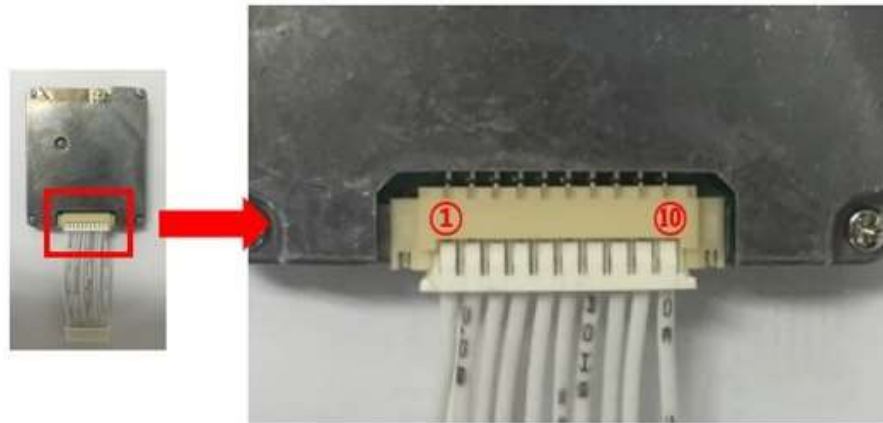

1	VCC	6	GND
2	VCC	7	TXD
3	VCC	8	RXD
4	GND	9	PWR_ON
5	GND	10	Not Used

 All That Identification	ATM2000 USER'S MANUAL								
	ATM2000 manual					Company	ATID Co.Ltd		
	Document		Writer	DJ Lee	Date	2017-01-24	Ver.	v0.1	

▶ Reader Specification

▷ Reader Performance

Description	Value
MODEL	ATM2000
Architecture	UHF RFID Reader Module
Protocol	EPCglobal UHF Class 1 Gen2 / ISO 18000-6C)
Frequency	902MHz to 928MHz
Max Tx Power	= < 30dBm (+-0.5dB)
Power Control	5dBm to 30dBm (1dB step)
Operating Temperature	-10°C to +50°C
Signaling	UART, Baud rate(115200bps)

▷ Electrical Characteristics

PARAMETER	SYMBOL	MIN	TYP	MAX	UNITS
Supply Voltage	VCC	3.8	4.0	4.2	V
VCC Supply Current	Icc			1.5	A
TXD (→HOST)	VOH		3.3		V
RXD (←HOST)	VIH		3.3		V
PWR_ON(Active "H")	VIH		3.3		V

	ATM2000 USER'S MANUAL								
	ATM2000 manual					Company	ATID Co.Ltd		
	Document		Writer	DJ Lee	Date	2017-01-24	Ver.	v0.1	

▷ **Interface**

Host Connector	Part No. : 12505WR-10 Manufacturer : Yeonho Electronics
ANT. Connector	Part No. : CMJ-S00 Manufacturer : Giga Lane

▶ Mechanical Dimension

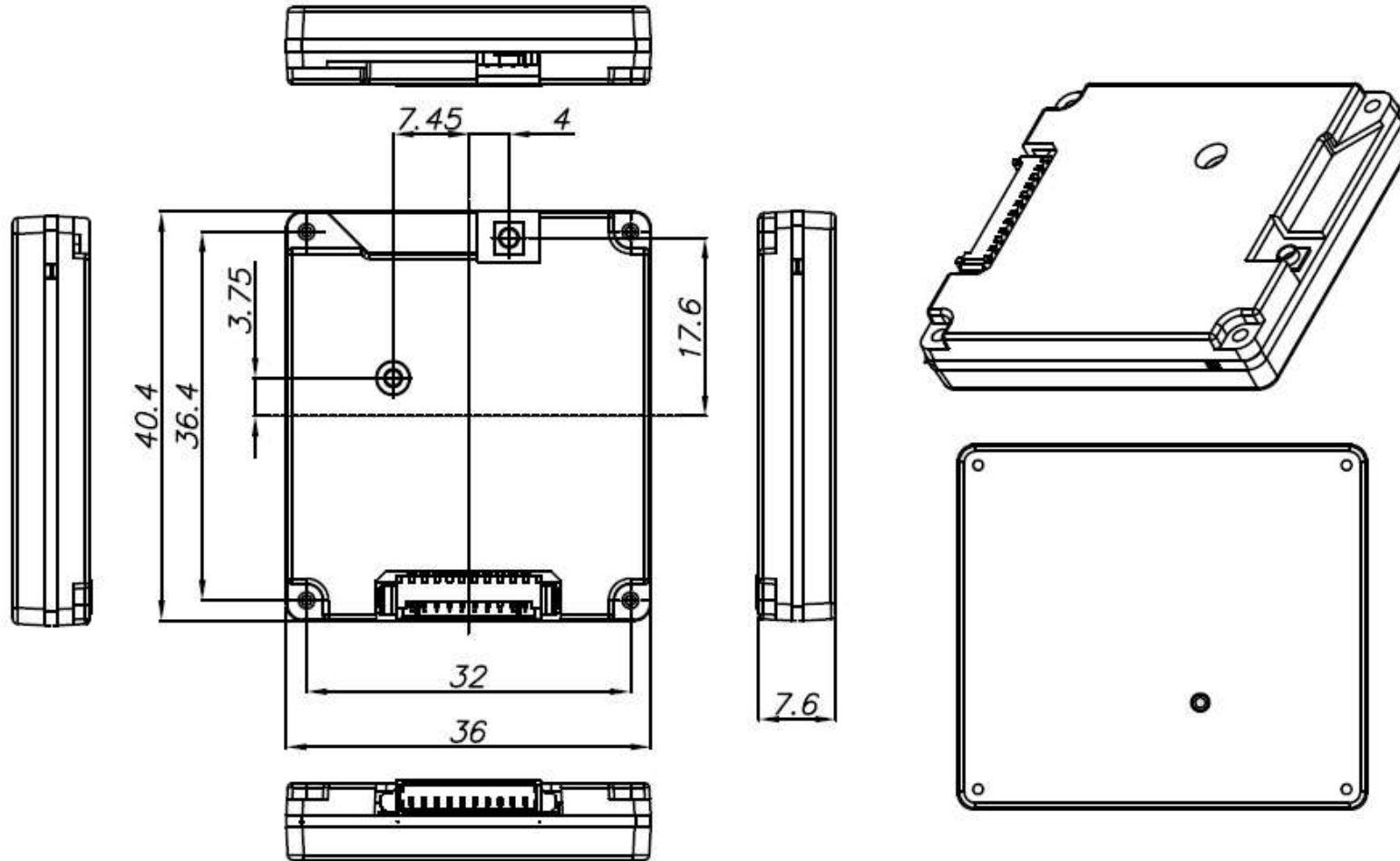

FCC Warning

This device complies with Part 15 of the FCC Rules. Operation is subject to the following two conditions:

(1) This device may not cause harmful interference, and (2) this device must accept any interference received, including interference that may cause undesired operation.

NOTE: Any changes or modifications to this unit not expressly approved by the party responsible for compliance could void the user's authority to operate the equipment.

FCC Radiation Exposure Statement:

This equipment complies with FCC radiation exposure limits set forth for an uncontrolled environment. End users must follow the specific operating instructions for satisfying RF exposure compliance.

Note 1: This module certified that complies with RF exposure requirement under mobile or fixed condition, this module is to be installed only in mobile or fixed applications.

A mobile device is defined as a transmitting device designed to be used in other than fixed locations and to generally be used in such a way that a separation distance of at least 20 centimeters is normally maintained between the transmitter's radiating structure(s) and the body of the user or nearby persons. Transmitting devices designed to be used by consumers or workers that can be easily re-located, such as wireless devices associated with a personal computer, are considered to be mobile devices if they meet the 20 centimeter separation requirement.

A fixed device is defined as a device is physically secured at one location and is not able to be easily moved to another location.

Note 2: Any modifications made to the module will void the Grant of Certification, this module is limited to OEM installation only and must not be sold to end-users, end-user has no manual instructions to remove or install the device, only software or operating procedure shall be placed in the end-user operating manual of final

products.

Note 3: Additional testing and certification may be necessary when multiple modules are used.

Note 4: The module may be operated only with the antenna with which it is authorized. Any antenna that is of the same type and of equal or less directional gain as an antenna that is authorized with the intentional radiator may be marketed with, and used with, that intentional radiator.

Note 5: To ensure compliance with all non-transmitter functions the host manufacturer is responsible for ensuring compliance with the module(s) installed and fully operational. For example, if a host was previously authorized as an unintentional radiator under the Declaration of Conformity procedure without a transmitter certified module and a module is added, the host manufacturer is responsible for ensuring that after the module is installed and operational the host continues to be compliant with the Part 15B unintentional radiator requirements. Since this may depend on the details of how the module is integrated with the host, ATID CO., LTD shall provide guidance to the host manufacturer for compliance with the Part 15B requirements.

Note 6: FCC ID label on the final system must be labeled with “Contains FCC ID: VUJATM2000S1” or “Contains transmitter module FCC ID: VUJATM2000S1”.