



**AT-R2000-S1
USER' S MANUAL**

V2.06.29

June 2012



| | | | |
|---|----------------------------------|------------|----------|
|  | AT-R2000-S1 User's Manual | | |
| | Company | Date | Version |
| | ATID Co.,Ltd | 2012-06-29 | V2.06.29 |

■ Revision history

| Version | Revision Date | Revision Page | Revision Description |
|---------|---------------|---------------|----------------------|
| V2.6.29 | 2012-06-29 | | Draft |
| | | | |
| | | | |
| | | | |
| | | | |
| | | | |
| | | | |
| | | | |
| | | | |
| | | | |
| | | | |
| | | | |
| | | | |
| | | | |
| | | | |
| | | | |
| | | | |
| | | | |
| | | | |
| | | | |

| | | | |
|---|----------------------------------|------------|----------|
|  | AT-R2000-S1 User's Manual | | |
| | Company | Date | Version |
| | ATID Co.,Ltd | 2012-06-29 | V2.06.29 |

Contents

| | |
|---|-----------|
| 1. Introduction & System composition diagram | 4 |
| ● Introduction | 4 |
| ● System composition diagram | 4 |
| 2. Composition parts | 5 |
| 3. Reader Description | 6 |
| 4. Reader Specification | 8 |
| ● Reader Performance (KOREA, USA, EUROPE, etc)..... | 8 |
| ● Interface..... | 8 |
| ● Physical Dimension..... | 8 |
| ● Channel number & Frequency table..... | 9 |
| ● Mechanical Dimension..... | 10 |
| 5. How to Run AT-R2000-S1 Sample Program | 11 |
| ◆ Appendix I : FCC Certification Requirements..... | 13 |

| | | | |
|---|---------------------------|------------|----------|
|  | AT-R2000-S1 User's Manual | | |
| | Company | Date | Version |
| | ATID Co.,Ltd | 2012-06-29 | V2.06.29 |

1. Introduction & System composition diagram

● Introduction

- The AT-R2000-S1 is a compact size RFID reader module developed for the embedded reader market, which comprises printers, industrial PDA, and similar devices. It provides customers with compact size, low cost, high performance functions. It supports protocols of ISO18000-6C(EPC C1G2), and it interfaces with a host system via UART.

- Target Application



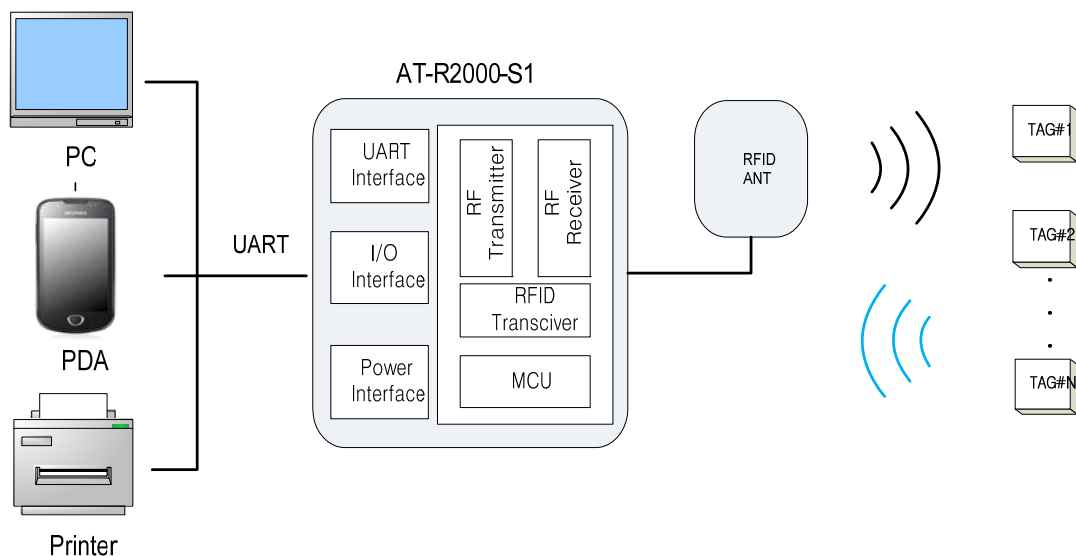

- PDA type RFID Reader
- RFID Printers / Tag Encoders
- USB Readers
- Smart-Shelves

● System composition diagram

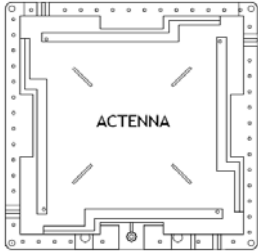

| | | | |
|---|----------------------------------|------------|----------|
|  | AT-R2000-S1 User's Manual | | |
| | Company | Date | Version |
| | ATID Co.,Ltd | 2012-06-29 | V2.06.29 |

2. Composition parts

| | |
|---|--|
| RFID Reader module |  |
| Interface Cable |  |
| ANTENNA (option) |  |
| UART to USB Convertor (option) |  |

| | | |
|---|---------------------------|------------|
|  | AT-R2000-S1 User's Manual | |
| | Company | Date |
| | ATID Co.,Ltd | 2012-06-29 |
| | | Version |
| | | V2.06.29 |

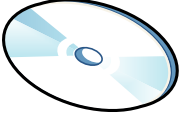
| | |
|---|---|
| Reader Software & User Document CD-ROM |  |
|---|---|

3. Reader Description

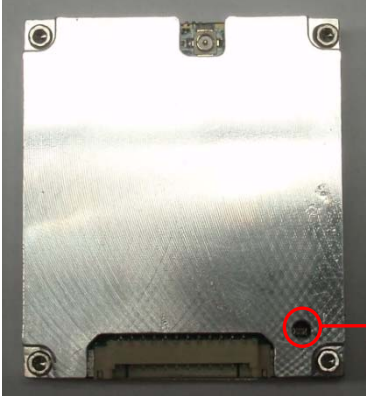
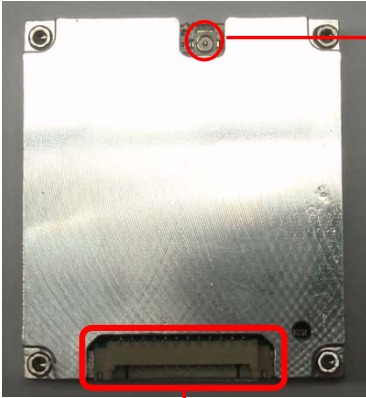
| |
|---|
| 상태 표시 LED |
|  |
| <div style="border: 1px solid blue; padding: 5px; width: fit-content; margin: auto;"> DATA LED : The Red LED will twinkle when the reader is receiving data from a tag. </div> |
| ANT Port |
|  |
| <div style="border: 1px solid blue; padding: 5px; width: fit-content; margin: auto;"> ANT Port : Connect RF Cable to reader module and ANT </div> |
| <div style="border: 1px solid blue; padding: 5px; width: fit-content; margin: auto;"> Interface connector : Supply voltage and interface with a host system(PC, PDA...) via UART. </div> |

| | | |
|--------------|------------|----------|
| Company | Date | Version |
| ATID Co.,Ltd | 2012-06-29 | V2.06.29 |

Interface Pin-map

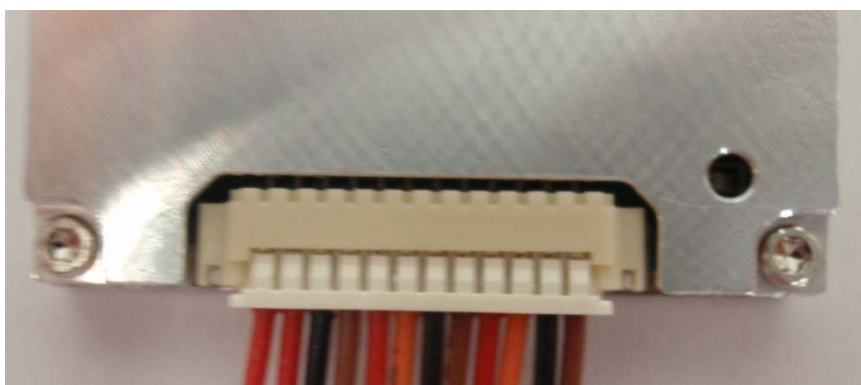

①

⑫

| | |
|----|--------------------------|
| 1 | VCC (3.8 ~ 4.2V, typ 4V) |
| 2 | VCC (3.8 ~ 4.2V, typ 4V) |
| 3 | GND |
| 4 | GND |
| 5 | GND |
| 6 | TXD (AT-R2000-S1 →HOST) |
| 7 | RXD (AT-R2000-S1← HOST) |
| 8 | PWR_ON |
| 9 | Not Used |
| 10 | Not Used |
| 11 | Not Used |
| 12 | Not Used |

| | | |
|---|----------------------------------|------------|
|  | AT-R2000-S1 User's Manual | |
| | Company | Date |
| | ATID Co.,Ltd | 2012-06-29 |
| | | Version |
| | | V2.06.29 |

4. Reader Specification

● Reader Performance (KOREA, USA, EUROPE, etc)

| Description | Value |
|--------------------------|--|
| MODEL | AT-R2000-S1 |
| Architecture | UHF RFID Reader Module |
| Protocol | EPC Gen2(ISO 18000-6C) |
| Frequency | 917.3MHz to 920.3MHz(Korea) 860MHz to 960MHz (Customizable) |
| Max Tx Power | 30dBm±1dBm (1W) |
| Power control | 5dBm to 30dBm (1dB step) |
| Hopping Channels | 6 (Korea), 50(USA), 4(EUROPE) |
| Channel Spacing | 600KHz (Korea, EUROPE), 500KHz(USA) |
| Channel Dwell time | < 0.4 seconds |
| Modulation Method | PR-ASK |
| Supply voltage | 3.8 ~ 4.2V (typ. : 4V) |
| Max Current (max. power) | < 1.4A |
| Tag Read Distance(Max.) | <10m |
| Operating Temperature | -10°C to +50°C |
| LED Indicators | Data |
| Signaling | UART, Baud rate(115200bps) |

● Interface

| | |
|-----------------------|--|
| Host connector | Part No. : 12505WR-12 Manufacturer : Yeonho Electronics |
| ANT Connector | Part No. : CMJ-S00 Manufacturer : Giga Lane |

● Physical Dimension

| | |
|--------|-------------------|
| SIZE | 36mm × 41mm × 8mm |
| Weight | 16g |

| | | | |
|---|----------------------------------|------------|----------|
|  | AT-R2000-S1 User's Manual | | |
| | Company | Date | Version |
| | ATID Co.,Ltd | 2012-06-29 | V2.06.29 |

● **Channel number & Frequency table**

| CHANNEL NO. | KOREA | USA | EUROPE | CHANNEL NO. | KOREA | USA | EUROPE |
|-------------|-------|--------|--------|-------------|-------|--------|--------|
| 0 | 917.3 | 902.75 | 865.7 | 25 | | 915.25 | |
| 1 | 917.9 | 903.25 | 866.3 | 26 | | 915.75 | |
| 2 | 918.5 | 903.75 | 866.9 | 27 | | 916.25 | |
| 3 | 919.1 | 904.25 | 867.5 | 28 | | 916.75 | |
| 4 | 919.7 | 904.75 | | 29 | | 917.25 | |
| 5 | 920.3 | 905.25 | | 30 | | 917.75 | |
| 6 | | 905.75 | | 31 | | 918.25 | |
| 7 | | 906.25 | | 32 | | 918.75 | |
| 8 | | 906.75 | | 33 | | 919.25 | |
| 9 | | 907.25 | | 34 | | 919.75 | |
| 10 | | 907.75 | | 35 | | 920.25 | |
| 11 | | 908.25 | | 36 | | 920.75 | |
| 12 | | 908.75 | | 37 | | 921.25 | |
| 13 | | 909.25 | | 38 | | 921.75 | |
| 14 | | 909.75 | | 39 | | 922.25 | |
| 15 | | 910.25 | | 40 | | 922.75 | |
| 16 | | 910.75 | | 41 | | 923.25 | |
| 17 | | 911.25 | | 42 | | 923.75 | |
| 18 | | 911.75 | | 43 | | 924.25 | |
| 19 | | 912.25 | | 44 | | 924.75 | |
| 20 | | 912.75 | | 45 | | 925.25 | |
| 21 | | 913.25 | | 46 | | 925.75 | |
| 22 | | 913.75 | | 47 | | 926.25 | |
| 23 | | 914.25 | | 48 | | 926.75 | |
| 24 | | 914.75 | | 49 | | 927.25 | |

| | | |
|---|---------------------------|------------|
|  | AT-R2000-S1 User's Manual | |
| | Company | Date |
| | ATID Co.,Ltd | 2012-06-29 |
| | | Version |
| | | V2.06.29 |

● Mechanical Dimension

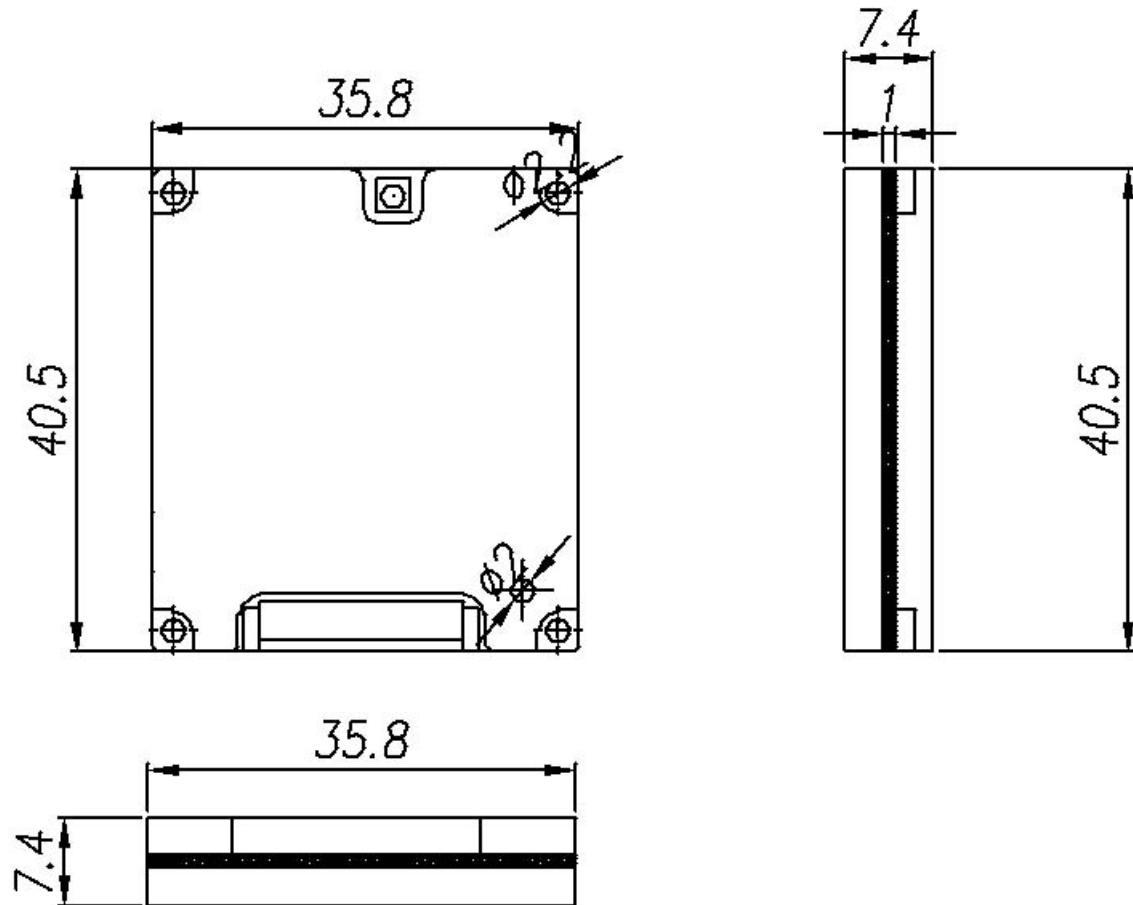

| | | | |
|---|----------------------------------|------------|----------|
|  | AT-R2000-S1 User's Manual | | |
| | Company | Date | Version |
| | ATID Co.,Ltd | 2012-06-29 | V2.06.29 |

5. How to Run AT-R2000-S1 Sample Program

1. Windows XP/7

1.1 File name :

Reader@Express V3.2.24.zip

1.2 Simple use :

0. **Add bluetooth device (Reader), and confirm relevant communication port in device manager.**

1. Decompress the file. Execute reader@express.exe.

2. **Designate communication port** → **Select from combo box located at top upper left side.**

3. **Click [OPEN] button** → It is right below the combo box located at upper left side

4. If it is normally connected

"RFID_OPEN() = 0 OK" is displayed in list box.

5. **If you click [INVENTORY MULTIPLE] button then it starts to read tag (Inventory).**

If tag is recognized,

Tag ID is displayed in list box → the latest one will be displayed at the most top.

Total number of readers is displayed → **It is displayed at just upper left side of list box in small size.**

Number of tags is displayed → **It is displayed at just upper right side of list box in large size.**

6. **If you click [StopOperation] button then it stops to read tag (Inventory).**

1.3 Notes :

Use it by setting POWER value as below 27 in upper combo box.

2. Android

2.1 File name :

AndroidSample.zip

2.2 Simple use :

It is SDK sample program for developers therefore it is not registered in the market.

You can directly install it in PC in following method.

1. Prepare Android phone and relevant data communication cable.

2. Download USB driver of relevant phone from Android phone manufacturer's homepage and install it in your PC.

3. Connect the phone to PC using data communication cable.

At this time, relevant drivers can be additionally installed through internet.

4. Execute command prompt (cmd.exe), and move to decompressed folder.

5. If you input as follows and execute it then it will be installed.

adb install -r ReaderApiBlueDemo.apk

You can connect with bluetooth reader in following method.

| | | | |
|---|----------------------------------|------------|----------|
|  | AT-R2000-S1 User's Manual | | |
| | Company | Date | Version |
| | ATID Co.,Ltd | 2012-06-29 | V2.06.29 |

1. **If you select [Search] in [Option menu],**
then the window to select bluetooth device appears.
Already paired devices are appeared on upper part.
Because you must search new device therefore click [Scan for devices]
Select the device name "Blue Angel" among searched devices at the lower part.
2. Only when you connect first time,
Pairing process is progressed – PIN number is "0000".
In most cases, it is connected normally after pairing.
3. Sometimes, it is not connected after pairing,
[Option menu]→[Search]→Select "Blue angel" in paired devices.

If you click [Inventory] button then it starts to read tag (Inventory).

If tag is recognized

Tag ID is displayed in list box → you can find the latest one on first top.

If you click [StopOperation] button then it stops to read tag (Inventory).

| | | | |
|---|---------------------------|------------|----------|
|  | AT-R2000-S1 User's Manual | | |
| | Company | Date | Version |
| | ATID Co.,Ltd | 2012-06-29 | V2.06.29 |

◆ Appendix I : FCC Certification Requirements

1. Caution

Any changed or modifications not expressly approved by the party responsible for compliance could void the user's authority to operate this equipment.

2. OEM installation guide

- I. OEM integrators must be instructed to ensure that the end-user has no manual instructions to remove or install the module.
- II. This module is to be installed only in mobile or fixed devices.
 - **Mobile device:** The device is to be generally used in such a way that a separation distance of at least 20cm is normally maintained between the transmitter's radiating structures and the body of the user or nearby persons.
 - **Fixed devices:** The device is physically secured at one location and is not able to be easily moved to another location.
- III. To ensure compliance with all non-transmitter functions the host manufacturer is responsible for ensuring compliance with the module(s) installed and fully operational.
- IV. To satisfy FCC exterior labeling requirements, the following text must be placed on exterior of the end product.
- V. An additional permanent label referring to the enclosed module: "Contains Transmitter Module FCC ID: XYZMODEL1" or "Contains FCC ID: XYZMODEL1" must be used. The host OEM user manual must also contain clear instructions on how end users can find and/or access the module and the FCC ID.

3. FCC RF exposure requirements

The antenna used with this module must be installed to provide a separation distance of at least 20cm from all persons, and must not transmit simultaneously with any other antenna or transmitter except in accordance with FCC multi-transmitter product procedures.

4. FCC authorization for this module

If this module is installed in portable devices or the different antenna configurations are used, the FCC authorizations are no longer considered valid and FCCID for module cannot be used on the final product. And the OEM installer will be responsible for re-evaluating the final product including this module and obtaining separate FCC authorization.

| | | | |
|---|----------------------------------|------------|----------|
|  | AT-R2000-S1 User's Manual | | |
| | Company | Date | Version |
| | ATID Co.,Ltd | 2012-06-29 | V2.06.29 |

5. Information for importation of radio frequency devices in to the United States.

To ensure compliance with all non-transmitter functions the host manufacturer is responsible for ensuring compliance with the module(s) installed and fully operational. For example, if a host was previously authorized as an unintentional radiator under the Declaration of Conformity procedure without a transmitter certified module and a module is added, the host manufacturer is responsible for ensuring that after the module is installed and operational the host continues to be compliant with the Part 15B unintentional radiator requirements.

Please see CFR47 Part 2 Subpart J Equipment Authorization Procedures, KDB784748 D01 v07, and KDB 997198.

6. User Information

This device complies with Part 15 of the FCC's Rule. Operation is subject to the following to conditions;

1. This device may not cause harmful interference, and
2. This device must accept any interference received, including interference that may cause undesirable operation.

This equipment has been tested and found to comply with the limits for a Class B digital device, pursuant to part 15 of the FCC Rules. These limits are designed to provide reasonable protection against harmful interference in a residential installation. This equipment generates, uses and can radiate radio frequency energy and, if not installed and used in accordance with the instructions, may cause harmful interference to radio communications. However, there is no guarantee that interference will not occur in a particular installation. If this equipment does cause harmful interference to radio or television reception, which can be determined by turning the equipment off and on, the user is encouraged to try to correct the interference by one or more of the following measures:

- Reorient or relocate the receiving antenna.
- Increase the separation between the equipment and receiver.
- Connect the equipment into an outlet on a circuit different from that to which the receiver is connected.
- Consult the dealer or an experienced radio/ TV technician for help.