



**AT-UHF900-S1
USER' S MANUAL**

V2.06.21

June 2012

This module is limited to OEM Installation only.





AT-UHF900-S1 User's Manual

Company	Date	Version
ATID Co.,Ltd	2012-06-21	V2.06.21

■ Revision history

Version	Revision Date	Revision Page	Revision Description
V1.8.17	2010-08-17		Draft
V1.10.18	2011-10-18	7	Add reset pin of Pin-map
V2.06.21	2012-06-21		



AT-UHF900-S1 User's Manual

Company	Date	Version
ATID Co.,Ltd	2012-06-21	V2.06.21

Contents

- 1. Introduction & System composition diagram4
 - Introduction4
 - System composition diagram4
- 2. Composition parts5
- 3. Reader Description6
- 4. Reader Specification8
 - Interface8
 - Physical Dimension8
 - Mechanical Dimension8
- ◆ Appendix I : FCC Certification Requirements.....9

1. Introduction & System composition diagram

● Introduction

- The AT-UHF900-S1 is a compact size RFID reader module developed for the embedded reader market, which comprises printers, industrial PDA, and similar devices. It provides customers with compact size, low cost, high performance functions. It supports protocols of ISO18000-6C(EPC C1G2), ISO18000-6B, and it interfaces with a host system via UART.



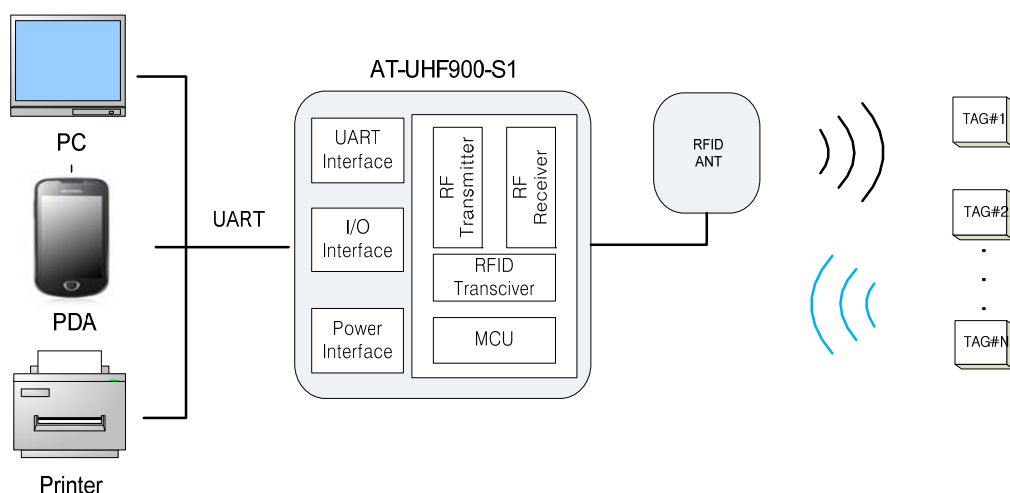

- Target Application

- PDA type RFID Reader
- RFID Printers / Tag Encoders
- USB Readers
- Smart-Shelves

● System composition diagram

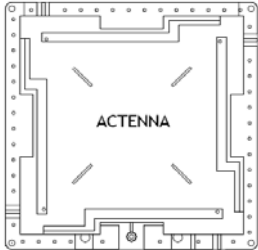

2. Composition parts

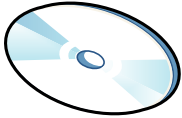
<p>RFID Reader module</p>	
<p>Interface Cable</p>	
<p>ANTENNA (option)</p>	
<p>UART to USB Convertor (option)</p>	
<p>Reader Software & User Document CD-ROM</p>	

3. Reader Description

LED Status



DATA LED : The Red LED will twinkle when the reader is receiving data from a tag.

POWER LED : The Red LED is turned on when the reader is powered. It can be removed for prevent battery consume.

ANT Port



ANT Port : Connect RF Cable to reader module and ANT

Interface connector :
Supply voltage and interface with a host system(PC, PDA...) via UART.

Interface Pin-map



①

⑫

1	VCC (3.8 ~ 4.2V, typ 4V)
2	VCC (3.8 ~ 4.2V, typ 4V)
3	GND
4	TXD (AT-UHF900-S1 →HOST)
5	RXD (AT-UHF900-S1 ← HOST)
6	Not Used
7	Not Used
8	Not Used
9	Not Used
10	Not Used
11	GND
12	RESET (It is necessary for Firmware update)



AT-UHF900-S1 User's Manual

Company	Date	Version
ATID Co.,Ltd	2012-06-21	V2.06.21

4. Reader Specification

● Interface

Host connector	Part No. : 12505WR-12 Manufacturer : Yeonho Electronics
ANT Connector	Part No. : CMJ-S00 Manufacturer : Giga Lane

● Physical Dimension

SIZE	33mm × 39mm × 7.5mm
Weight	20g

● Mechanical Dimension

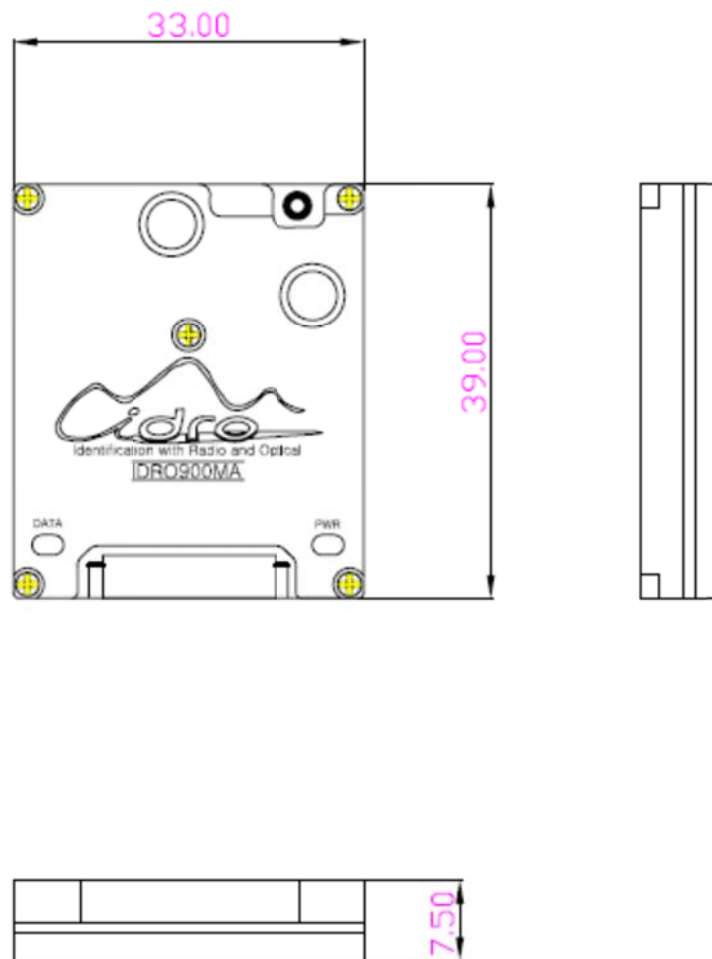

	AT-UHF900-S1 User's Manual		
	Company	Date	Version
	ATID Co.,Ltd	2012-06-21	V2.06.21

◆ Appendix I : FCC Certification Requirements

1. Caution

Any changed or modifications not expressly approved by the party responsible for compliance could void the user's authority to operate this equipment.

2. OEM installation guide

- I. OEM integrators must be instructed to ensure that the end-user has no manual instructions to remove or install the module.
- II. This module is to be installed only in mobile or fixed devices.
 - **Mobile device:** The device is to be generally used in such a way that a separation distance of at least 20cm is normally maintained between the transmitter's radiating structures and the body of the user or nearby persons.
 - **Fixed devices:** The device is physically secured at one location and is not able to be easily moved to another location.
- III. To ensure compliance with all non-transmitter functions the host manufacturer is responsible for ensuring compliance with the module(s) installed and fully operational.
- IV. To satisfy FCC exterior labeling requirements, the following text must be placed on exterior of the end product.
- V. An additional permanent label referring to the enclosed module: "Contains Transmitter Module FCC ID: XYZMODEL1" or "Contains FCC ID: XYZMODEL1" must be used. The host OEM user manual must also contain clear instructions on how end users can find and/or access the module and the FCC ID.

3. FCC RF exposure requirements

The antenna used with this module must be installed to provide a separation distance of at least 20cm from all persons, and must not transmit simultaneously with any other antenna or transmitter except in accordance with FCC multi-transmitter product procedures.

4. FCC authorization for this module

If this module is installed in portable devices or the different antenna configurations are used, the FCC authorizations are no longer considered valid and FCCID for module cannot be used on the final product. And the OEM installer will be responsible for re-evaluating the final product including this module and obtaining separate FCC authorization.

	AT-UHF900-S1 User's Manual		
	Company	Date	Version
	ATID Co.,Ltd	2012-06-21	V2.06.21

5. Information for importation of radio frequency devices in to the United States.

To ensure compliance with all non-transmitter functions the host manufacturer is responsible for ensuring compliance with the module(s) installed and fully operational. For example, if a host was previously authorized as an unintentional radiator under the Declaration of Conformity procedure without a transmitter certified module and a module is added, the host manufacturer is responsible for ensuring that after the module is installed and operational the host continues to be compliant with the Part 15B unintentional radiator requirements.

Please see CFR47 Part 2 Subpart J Equipment Authorization Procedures, KDB784748 D01 v07, and KDB 997198.

6. User Information

This device complies with Part 15 of the FCC's Rule. Operation is subject to the following to conditions;

1. This device may not cause harmful interference, and
2. This device must accept any interference received, including interference that may cause undesirable operation.

This equipment has been tested and found to comply with the limits for a Class B digital device, pursuant to part 15 of the FCC Rules. These limits are designed to provide reasonable protection against harmful interference in a residential installation. This equipment generates, uses and can radiate radio frequency energy and, if not installed and used in accordance with the instructions, may cause harmful interference to radio communications. However, there is no guarantee that interference will not occur in a particular installation. If this equipment does cause harmful interference to radio or television reception, which can be determined by turning the equipment off and on, the user is encouraged to try to correct the interference by one or more of the following measures:

- Reorient or relocate the receiving antenna.
- Increase the separation between the equipment and receiver.
- Connect the equipment into an outlet on a circuit different from that to which the receiver is connected.
- Consult the dealer or an experienced radio/ TV technician for help.