



AX7

User Manual

Revision: 03
Revision Date: 2012/06/25

Contents

1.	Notification	3
	1.1. Disclaimer	3
	1.2. Copyright.....	3
	1.3. Warning.....	3
2.	Introduction.....	4
	2.1. Package Content	4
	2.2. AX7 OBD-II Compliant.....	4
3.	Hardware Features	5
	3.1. OBD-II Protocol.....	5
	3.2. Micro USB Connection.....	5
	3.3. Buzzer Operation	5
	3.4. Power Supply.....	5
	3.5. Wireless Relay	6
	3.6. LED Indication.....	6
4.	Configuration	7
	4.1. USB Driver Installation.....	7
	4.2. Configure the AX7 device	10
	4.3. Firmware Upgrade	15
5.	Installation.....	17
	5.1. What is the OBD-II DLC Connector	17
	5.2. Using Low Profile OBD-II Extension Cable.....	18
	5.3. GPS Performance for Installation	19
	5.4. Simple Verification for Installation	20
6.	Appendix.....	21
	6.1. Hardware Specification	21
	6.2. FCC Regulations:.....	22

1. Notification

1.1. Disclaimer

This document, and all other related products, such as device, firmware, and software, is developed by ATrack Technology Inc. thoroughly. At the time of release, it is most compatible with specified firmware version. Due to the functionalities of the devices are being developed and improved from time to time, the change in the protocol, specification, and firmware functions are subjects to change without notice. ATrack Technology Inc. is obligated to modify all the documentation without the limitation of time frame. A change notice shall be released to ATrack Technology Inc. customers upon the completion of document modification.

ATrack Technology Inc. products are not intended to be used as life support or rescue equipments. ATrack Technology Inc. is not liable for any loss or injury caused by using or referencing to any products. Any possible means of using or integrating ATrack Technology Inc. products shall be avoided.

1.2. Copyright

ATrack Technology Inc. holds all parts of intellectual rights applicable in the copyright laws in all the countries. Any or all parts of this document shall not be exposed to non-authorized party without any form of approval from ATrack Technology Inc. Any forms, including but not limited to oral, copy, or internet sharing, of releasing or exposing information to an unauthorized party shall be prohibited. ATrack Technology Inc. reserves the rights of litigation in the violation of such copyright laws.

1.3. Warning

Connecting the wire inputs can be hazardous to both the installer and your vehicle's electrical system if not done by an experienced installer. This document assumes you are aware of the inherent dangers of working in and around a vehicle and have a working understanding of electricity.

2. Introduction

AX7 GPS Tracking Device is the most advanced and economical diagnostic device for communicating vehicle information to the GSM/GPRS networks. With integrated high sensitive GPS receiver, the AX7 provides the fundamental functions with optional advance features for tracing light trucks and passenger vehicles in need of monitoring location, speed, and many other codes available on the OBD port of vehicles.

2.1. Package Content

Each package contains the following standard device/accessories:

- AX7 Device * 1



- USB Cable * 1



Optional accessories:

- Low Profile OBD-II Extension Cable



- Wireless Relay



2.2. AX7 OBD-II Compliant

OBD-II is a standard that issued by SAE (Society of Automotive Engineers) in the early 1990s. But some vehicles are not following this standard. Therefore ATrack cannot guarantee the OBD-II performance of the AX7 with every vehicle. For more information about AX7 OBD-II compliance, please refer to “ATrack AX7 OBD-II Compliant Guide” document.

3. Hardware Features

3.1. OBD-II Protocol

There are five signaling protocols that are permitted with the OBD-II interface. Most vehicles have been implemented with only one of the protocols. The AX7 features a superior protocol detection algorithm that ensures the device connects reliably even to vehicles that do not fully conform to the OBD-II standards. The AX7 supported all legislated OBD-II protocols below:

- J1850 PWM (Ford vehicles)
- J1850 VPW (GM vehicles)
- ISO9141-2 (Asian, European, Chrysler vehicles)
- ISO 14230-4 KWP
- ISO 15765-4 CAN (11/29 bit ID,250/500 Kbaud)

The AXTool has an “OBD Live Data” viewer for showing OBD data in real time. See Section 4.2 for detail descriptions.

3.2. Micro USB Connection

The Micro USB can supply power to the AX7 device for parameters setting or firmware upgrade purpose. When micro USB is connected to your laptop/PC and main power is not applied, the OBD-II and GSM/GPRS functions will be turned off temporarily.

3.3. Buzzer Operation

The internal buzzer of the AX7 can be configured by any events or triggered by remote GSM/GPRS server. Refer to AX7 Protocol Document for details.

3.4. Power Supply

The AX7 device connects to the OBD-II SAE J1962 connector of vehicle and draws power from the OBD port. No additional power cabling is required for operation. If the OBD port of vehicle is covered or you need to install AX7 in another place for better GPS reception, the optional low profile OBD-II extension cable is required.

3.5. Wireless Relay

The optional wireless relay is used for immobilizing vehicle when AX7 device is unplugged. Using the short range RF technology, the Wireless Relay will keep receiving RF data from AX7. Once the Wireless Relay loses connection from AX7 for 30 seconds, the Wireless Relay will be switched off. For safety reasons it is recommended to connect the Wireless Relay to control the starter of vehicle. Do NOT use the Wireless Relay to control fuel pump or power train of vehicle. See the following diagram for the wiring connection of Wireless Relay.

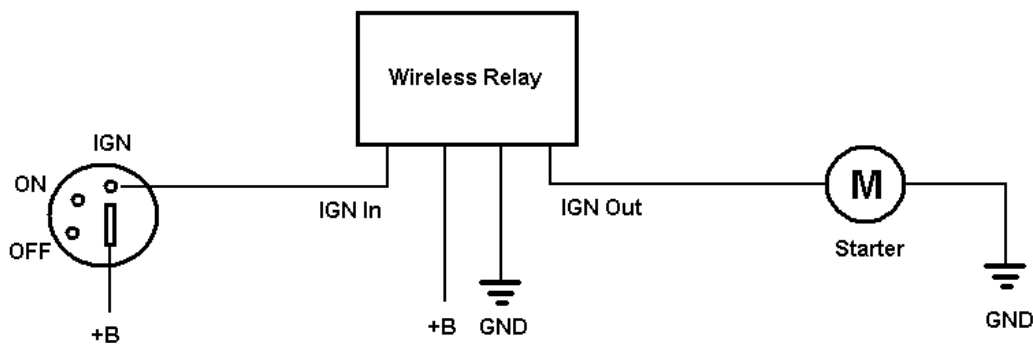

3.6. LED Indication

The following table describes the LED operation of AX7:

LED Indicators	Color	LED Status	Description
OBD	Green	Solid OFF Fast blinking Blinking every 10 seconds	OBD Protocol not found OBD-II data transmission. Deep sleep mode
GPS	Blue	Solid OFF Blinking every 1 second Solid ON	GPS power OFF GPS not fix GPS Location Fix
GSM	Red	Solid OFF Blinking every 1 second Blinking every 2 second Blinking twice every 2 second	GSM Power OFF GSM no signal GSM registered GPRS connected

4. Configuration

4.1. USB Driver Installation

These instructions illustrate how to correctly install the USB driver in Windows platform. The procedure will vary for other Windows-based Operating Systems.

1. Connect the Device to the USB port on a Windows-based computer.
2. Install the USB driver.

● Connect the device to a USB Port

Supported Operating Systems including Windows 2000, Windows XP, Windows 7 and Windows Vista. When you connect the device to the computer, you will be prompted to install the driver.

Follow the steps in the next section to install the driver.

● Install the USB Driver

The AX7 USB Driver can be requested from ATrack support via email or from the Partner Login section of the ATrack website at www.atrack.com.tw.

After connecting the device to the computer, follow these steps to complete the installation of the USB driver:

There might be multiple steps to installing the USB driver. Once each step is completed, the next step will automatically begin itself.

The following screen captures may reflect a different device driver than the one you are installing; however, the steps in the procedure will remain the same.

1. The Windows Operating System will detect the new USB device.
2. You will see the following screen for no driver found:

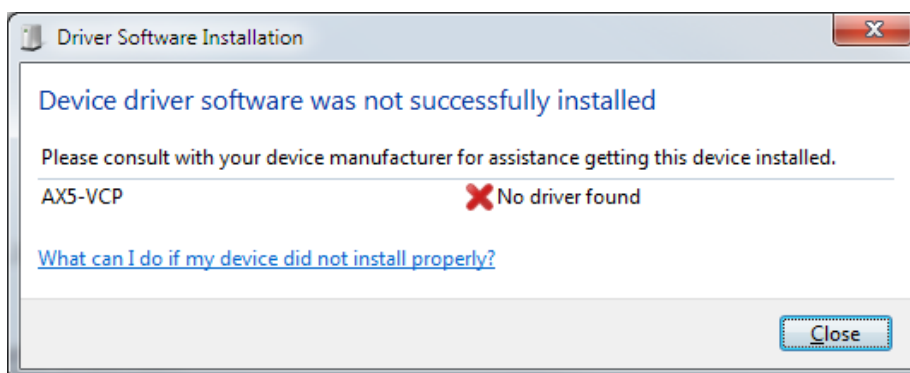

3. To install the driver, click on "Browse my computer for driver software"

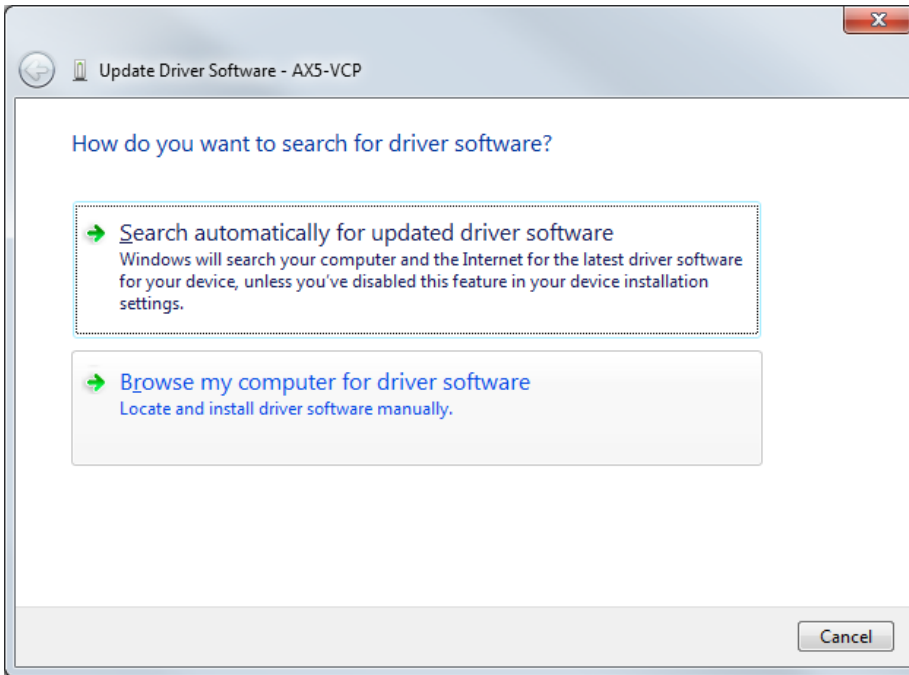

4. Click on "Browse" button, and go to the driver provided/downloaded from ATrack.

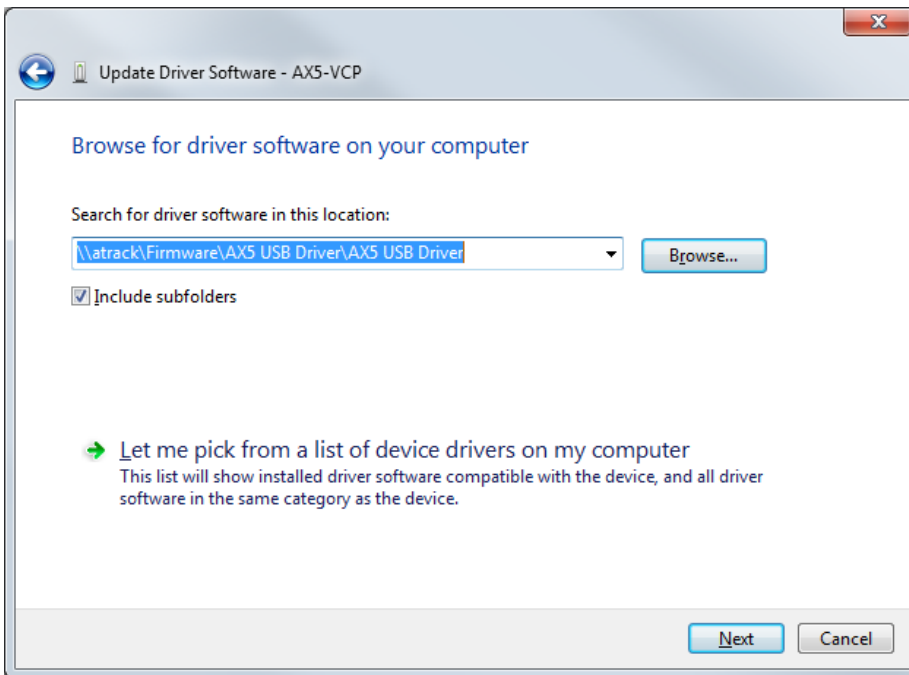

5. Windows might give a warning about the verification fail. Please click on "Install this driver software anyway" to proceed.

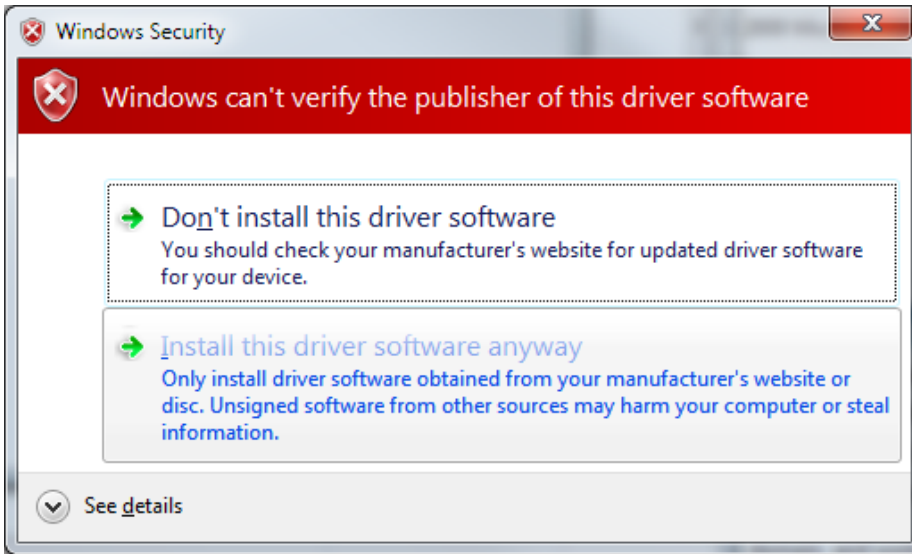

6. You should be able to see a progress bar running.

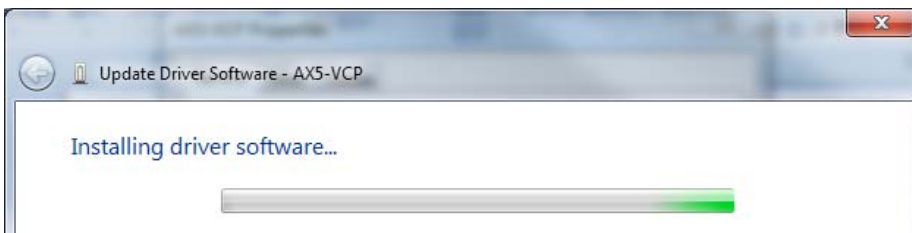

7. Once the installation is completed, you should be able to see the COM port showing. This will be the COM port you use for communicate with the AX7 when USB is plugged in.



4.2. Configure the AX7 device

The AXTool is a simple configuration tool for the AX7 device. It is useful for user to setting basic parameters into the AX7 device. For advanced users, please refer to the ATrack A-Series Protocol Document for detail descriptions.

- **General Setting**

[Device Password]: The device password is used for protecting device configurations. The maximum length is 6 characters.

[SIM Card PIN Code]: Enter PIN code of SIM card correctly for register to network property if enabled.

[Position Format]: Select position format for all reports.

[Power Saving Mode]: Enable/Disable power saving mode. When power saving mode is enabled, the AX7 device will go into deep sleep mode after 1 minute of engine off.

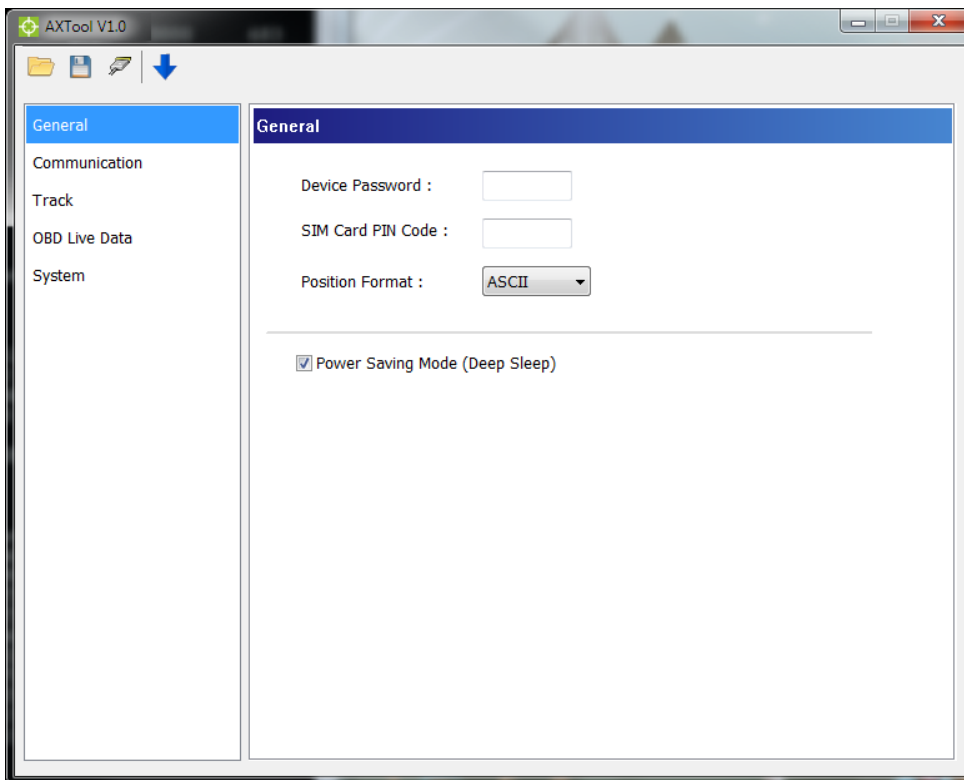

- **Communication Setting**

[GPRS Enable]: Enable GPRS communication

[Socket Type]: Select TCP or UDP for GPRS communication

[APN]: Access Point Name for GPRS connection. (Please contact your cellular network carrier for the information)

[Host IP]: Enter the IP address or domain name of host server

[Host Port]: Enter Port number of the remote host server

[User Name]: The GPRS user name. (Please contact your cellular network carrier for the information)

[Password]: The GPRS password. (Please contact your cellular network carrier for the information)

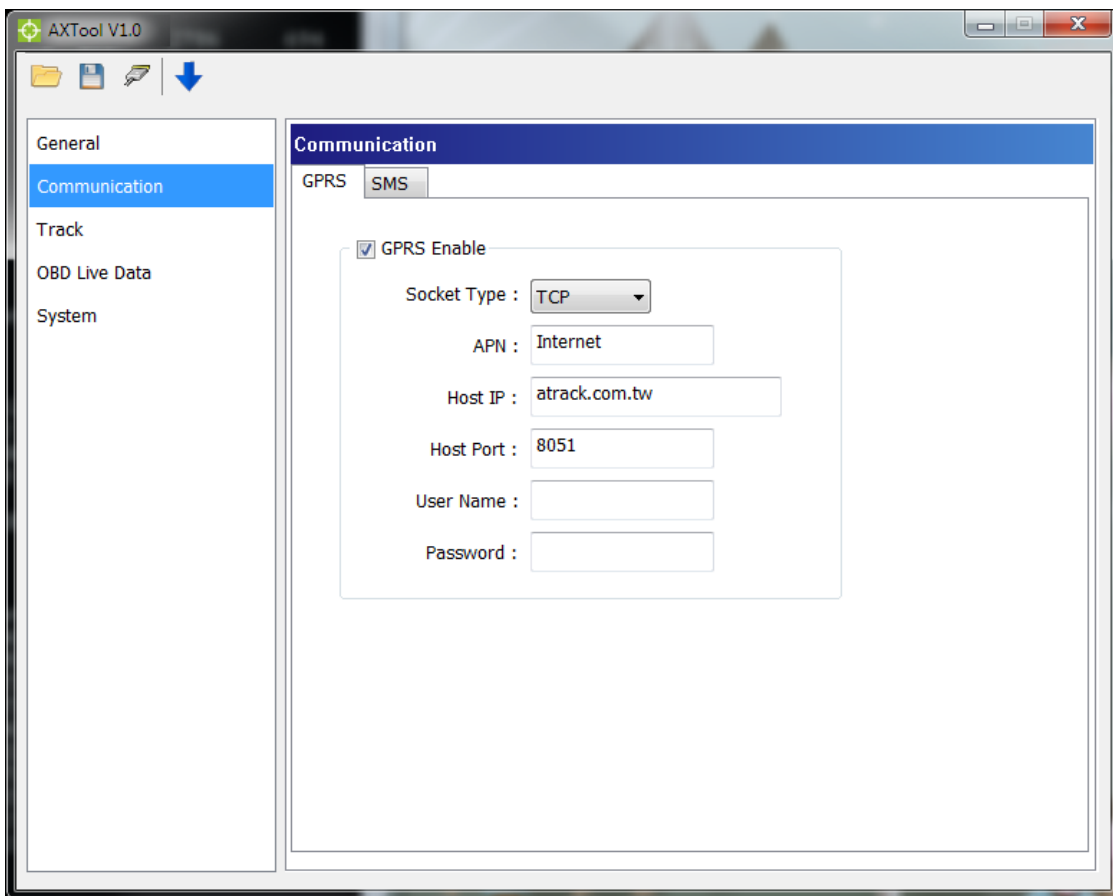

- **Track Setting**

Setting tracking interval when vehicle engine is ON.

When [Time Mode] and [Distance Mode] are both selected, the tracking behavior will operate in AND condition.

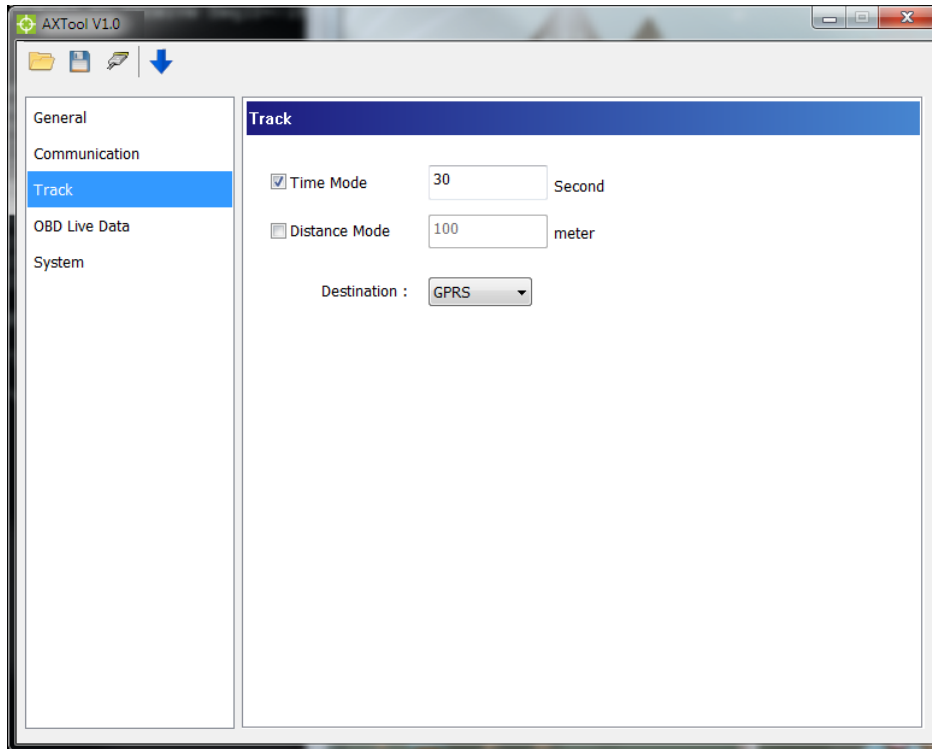

● **OBD Live Data**

When AX7 has connected to the OBD-II port of the vehicle. The [OBD Live Data] will showing the OBD live data from OBD-II port. This viewer could help to know which OBD data can be acquired by AX7 device.

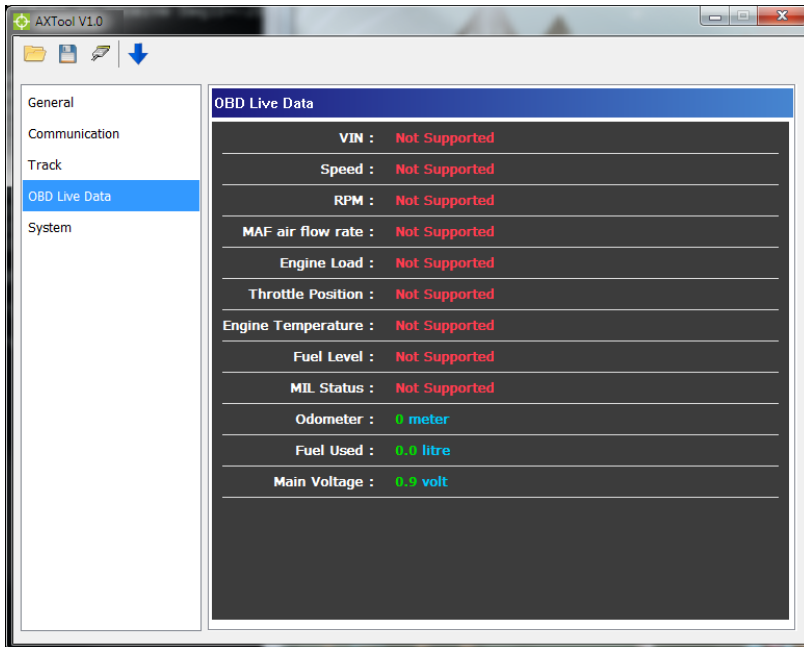

● **System Setting**

The [System] setting will showing current connected AX7 device information. The [Reset/Action] function can be used to reset parameters or clear buffered messages in the AX7 device.

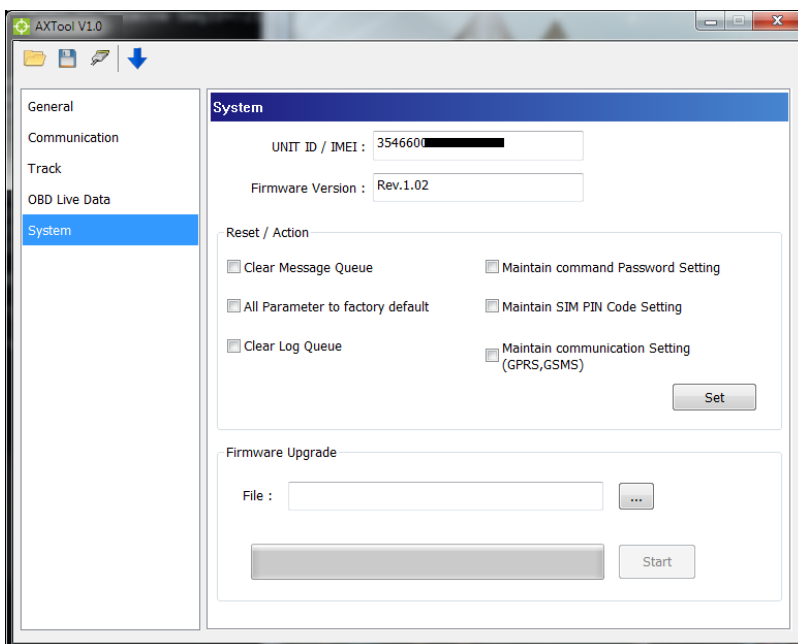

- **Uploading Setting To Device**

Once all the settings are entered, use the Blue Downward Arrow (↓) to upload the settings to the device. A popup window will show the progress. When it finishes, the popup window will close.

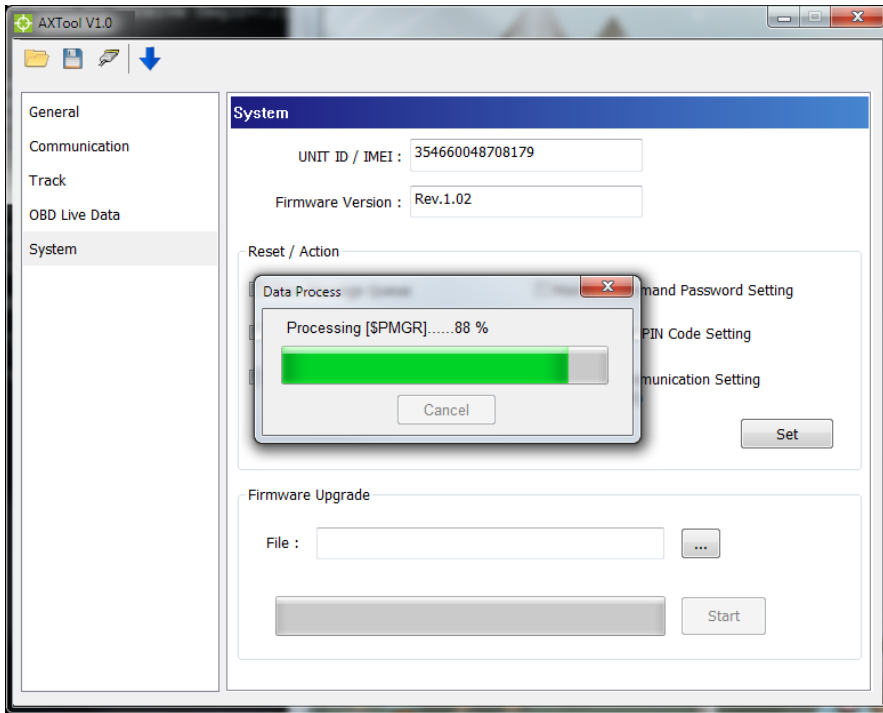

4.3. Firmware Upgrade

Open AXTool program and click [System] item of the manu.

Select firmware file which is provided by ATrack and click [Start] button.

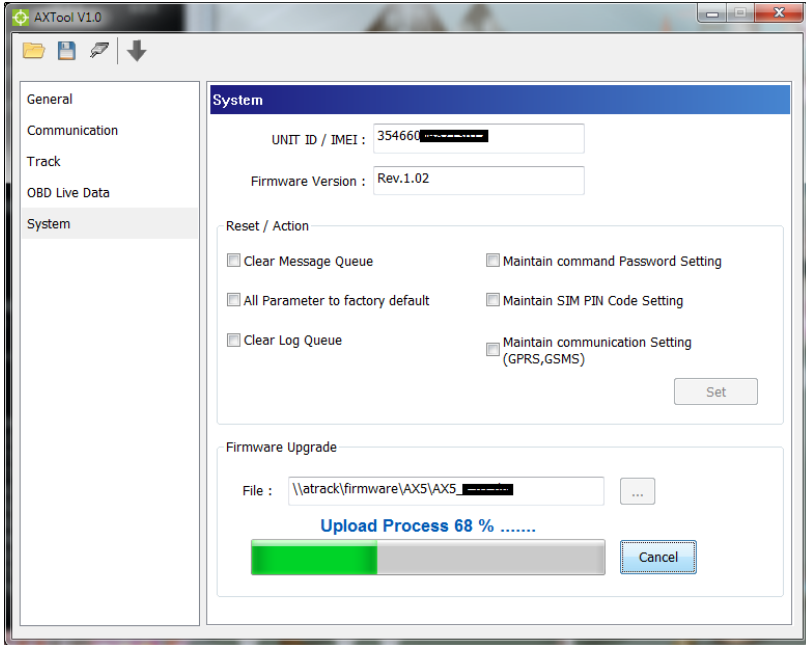

When “Waiting Device Restart...” message is prompted, please do not turn off the device.

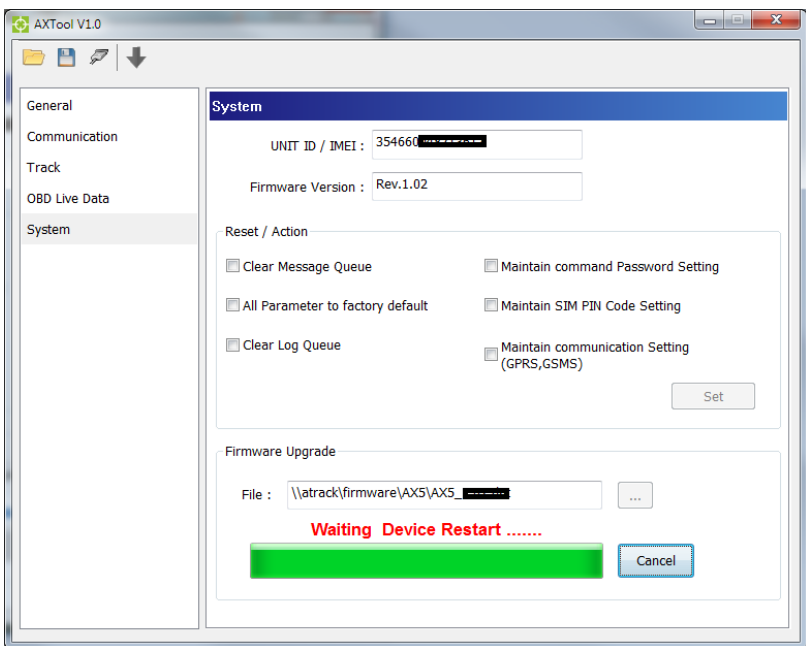

When “Upgrade Successfully !!” message is prompted, that means the device firmware is upgraded.

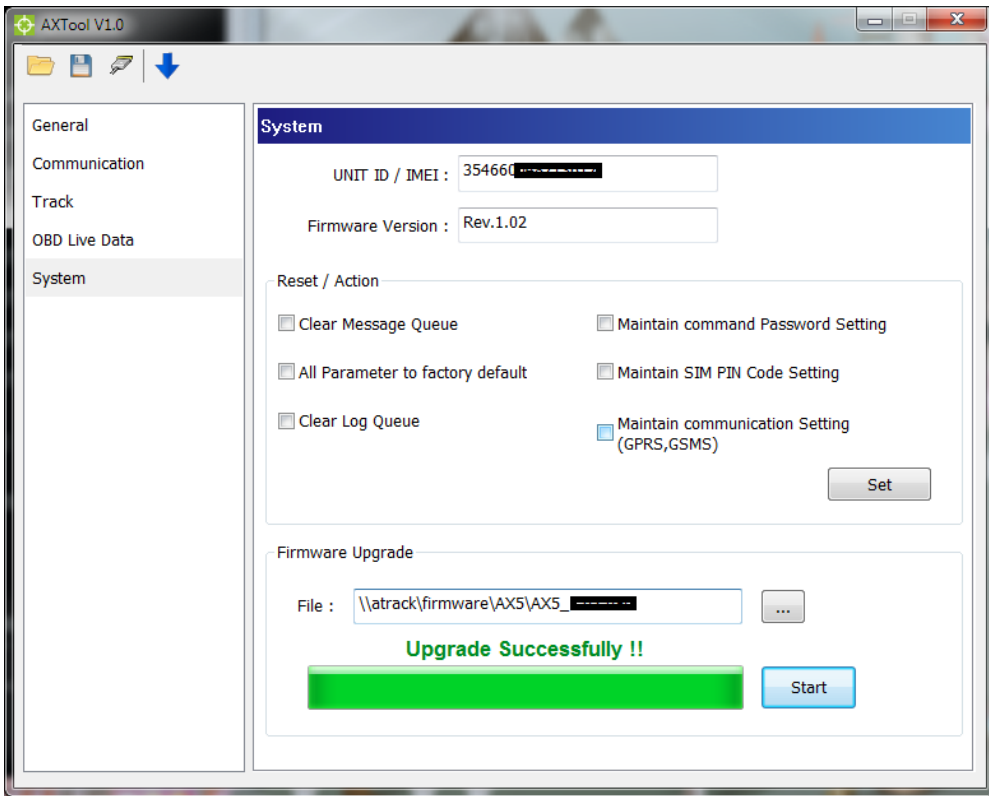

5. Installation

AX7 is a new design for easy installation. Just find the DLC connector of your vehicle and plug AX7 to the port.

5.1. What is the OBD-II DLC Connector

The OBD-II DLC connector is a standard connector for all vehicles which OBD-II compliant. The OBD-II DLC connector is shown below:

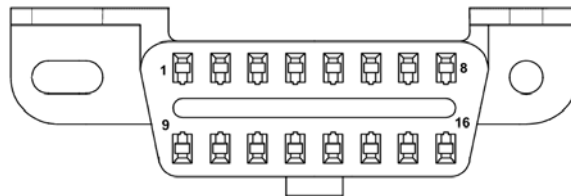

The OBD-II DLC connector shall be located in the passenger or driver's compartment in the area bounded by the driver's end of the instrument panel to 300 mm beyond the vehicle centerline. See the following figure for DLC location for most of vehicle. Location #1~#3 is under the dashboard of the driver side. Location #4~#5 is on the dashboard instrument/gauge area. Location #6~#7 is near radio and climate controller. Location #8 is near armrest and handbrake area.

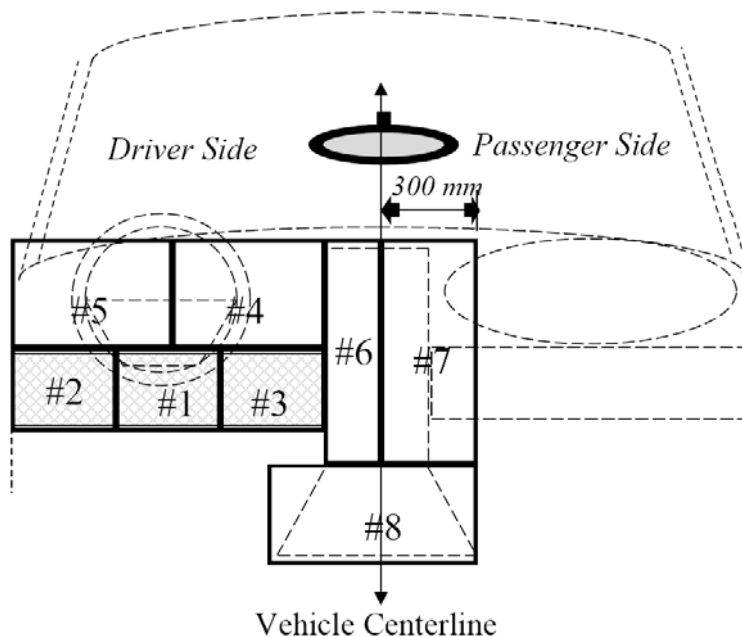

5.2. Using Low Profile OBD-II Extension Cable

The OBD-II DLC location is different for every kind of vehicles. For example, the DLC is covered by plastic cover like picture below. The AX7 device is too long to hide when AX7 plug into the DLC connector. The low profile OBD-II extension cable can solve this problem. Another advantage of this cable is to re-location of the AX7 device for better GPS performance.



5.3. GPS Performance for Installation

The AX7 determines its position by communicating with the Global Positioning Satellites through internal GPS antenna. The location chosen of the AX7 will have a lot to do with the overall performance of the GPS receiver. The AX7 device has internal GPS antenna but it is not a water proof design. Therefore, it shall be interior installed. Please note that the following interior conditions may cause bad GPS reception of AX7:

- Your vehicle has metallic window tint
- Your vehicle has a windshield mounted radio antenna
- Your vehicle has a solar reflective window

The AX7 installation direction shall be considered as well. Please see the following figure:

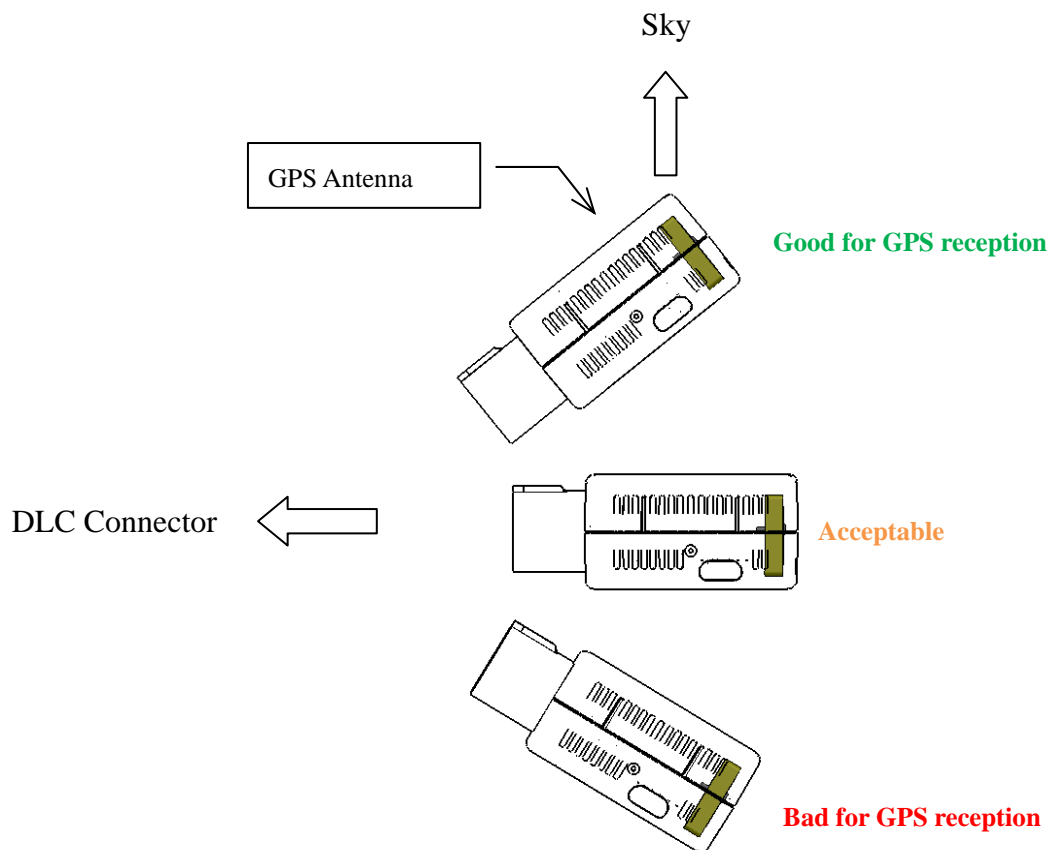

The AX7 used the latest GPS autonomous technology which accelerates GPS positioning by capitalizing on the periodic nature of GPS satellite orbits. GPS orbit predictions are directly calculated by the GPS receiver and no external aiding data or connectivity is required. Therefore, more satellites received are benefit for GPS fix under low signal environment for the next 3~4 days.

5.4. Simple Verification for Installation

When the device is configured and first plugged into the OBD port. The AX7 will have some buzzer indications for basic function test. The user can simply to verify if the AX7 device is installed properly.

Buzzer Indication	Description
Beep 1 time	Device Power ON
Beep 2 times	OBD Protocol Connected
Beep 3 times	GSM/GPRS Connected
Beep 4 times	GPS Fix

6. Appendix

6.1. Hardware Specification

AX7	
GSM/GPRS Specification	
GSM Module	Quad band (850/900/1800/1900MHz) Tri-band UMTS 850/1900/2100 MHz
Communication	SMS/USSD/GPRS /TCP/UDP
GSM Antennas	Internal Type
GPS Specification	
GPS Receiver	50 Channels, L1 Band, C/A Code
Sensitivity	-159dBm
Accuracy	2.5m CEP
Assisted GPS	Supported
OBD-II Specification	
Supported Protocol	ISO 15765-4 (CAN) ISO 14230-4 (KWP2000) ISO 9141-2 (Asian, European, Chrysler vehicles) SAE J1850 VPW (GM vehicles) SAE J1850 PWM (Ford vehicles)
Electrical Characteristics	
Power Source	8-35 VDC
Power Consumption	Operational 140 mA @ 12VDC (Average) Sleep 18 mA @ 12VDC Deep Sleep <2 mA @ 12VDC
Mechanical Specification	
Dimension	50 x 46 x 25 mm
OBD Connector	SAE J1962 Type A
Weight	54g (Include OBD Option)
Environmental Characteristics	
Operation Temperature	-25 ~ +70°C
Storage Temperature	-40 ~ +85°C
Humidity	5 ~ 95%

6.2. FCC Regulations:

- This device complies with part 15 of the FCC Rules. Operation is subject to the following two conditions: (1) This device may not cause harmful interference, and (2) this device must accept any interference received, including interference that may cause undesired operation.

- This device has been tested and found to comply with the limits for a Class B digital device, pursuant to Part 15 of the FCC Rules. These limits are designed to provide reasonable protection against harmful interference in a residential installation. This equipment generates, uses and can radiated radio frequency energy and, if not installed and used in accordance with the instructions, may cause harmful interference to radio communications. However, there is no guarantee that interference will not occur in a particular installation. If this equipment does cause harmful interference to radio or television reception, which can be determined by turning the equipment off and on, the user is encouraged to try to correct the interference by one or more of the following measures:

- Reorient or relocate the receiving antenna.

- Increase the separation between the equipment and receiver.

- Connect the equipment into an outlet on a circuit different from that to which the receiver is connected.

- Consult the dealer or an experienced radio/TV technician for help.

Changes or modifications not expressly approved by the party responsible for compliance could void the user's authority to operate the equipment.

▶ RF Exposure Information

This device meets the government's requirements for exposure to radio waves.

This device is designed and manufactured not to exceed the emission limits for exposure to radio frequency (RF) energy set by the Federal Communications Commission of the U.S. Government.

- This device complies with FCC radiation exposure limits set forth for an uncontrolled environment. In order to avoid the possibility of exceeding the FCC radio frequency exposure limits, human proximity to the antenna shall not be less than 20cm (8 inches) during normal operation.