



Inari 8.3"

Quick Start Guide

Version 3.1

Inari features, buttons & interfaces

Front

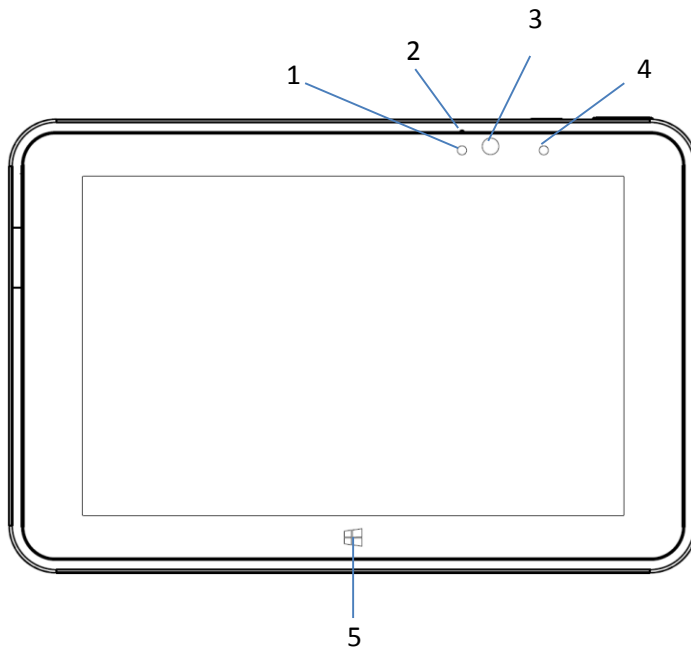

-
- | | |
|----------|---|
| 1 | Ambient Light Sensor
Recognizes the ambient light and adjusts the display brightness if enabled in the operating system |
| 2 | Front microphone outlet |
| 3 | Front camera
2MP camera for video conferencing |
| 4 | Indicator LED
Lights up if camera is activated and during device boot and shutdown |
| 5 | Windows Button
Touch it to return to the start menu |
-

Top side

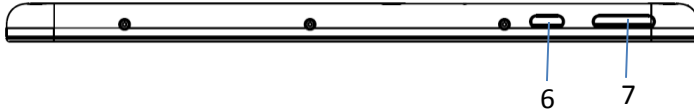

- 6** On / Off Button
Push it once to start the tablet; push it again to enable the sleep mode. Push and hold it to shut down the device.
- 7** Volume key
Push the left side to reduce the volume, use the right side to increase the volume

Right and Bottom side

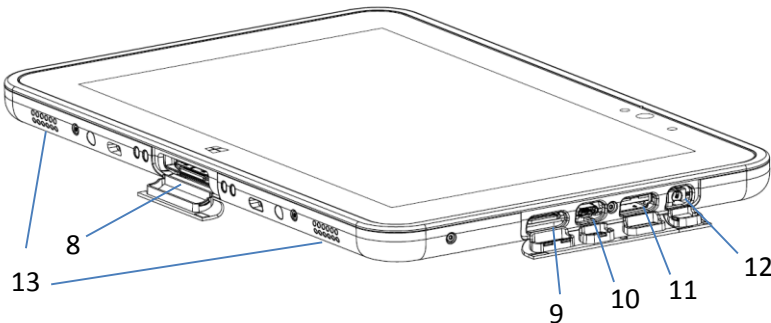

- 8** Docking connector
- 9** MicroSDXC card slot
- 10** MicroUSB interface
For charging only!
- 11** USB 2.0 port
- 12** Audio jack
combined microphone & speaker connector
- 13** Stereo speakers

Rear view

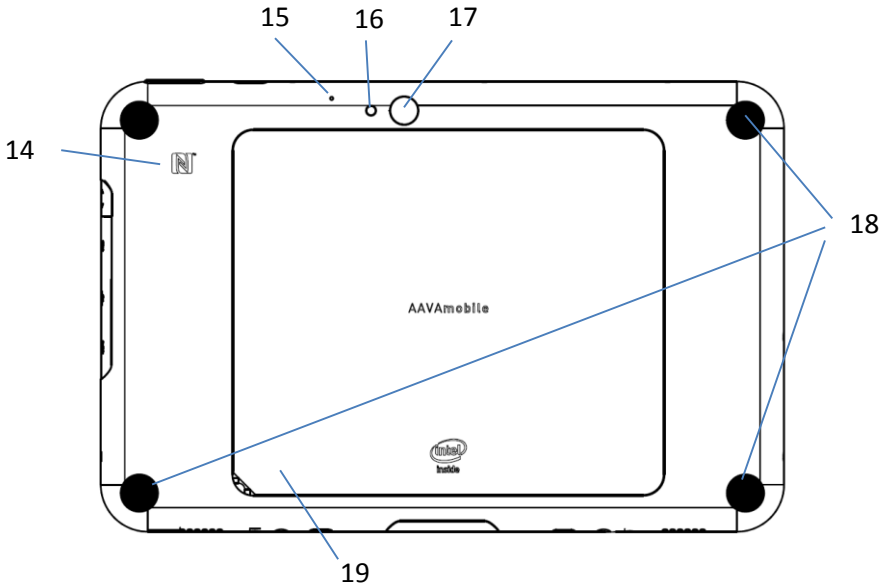

- | | |
|-----------|--|
| 14 | NFC antenna position
Can be used to read NFC & RFID tags |
| 15 | Rear microphone outlet |
| 16 | Camera flash LED |
| 17 | Rear camera
8MP camera for high resolution images & video |
| 18 | Mechanical fixing points behind covers |
| 19 | Battery lid |

Replacing Battery / Adding SIM card

To replace the battery, take of the battery lid by pulling on the lid carefully. Pull on the battery holder hook (1) to the bottom of the device. Pull the battery up (2), and pull on the second battery holder hook (3).

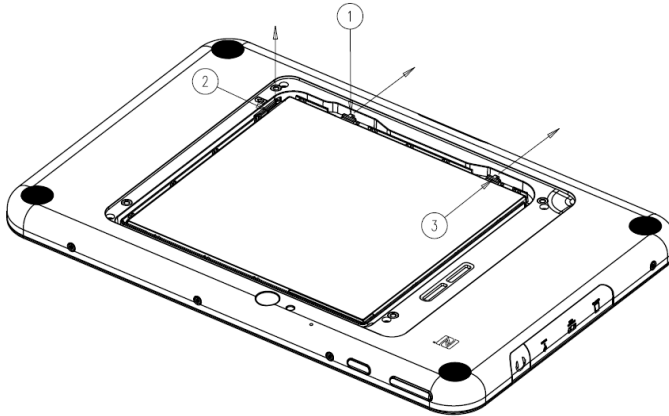

Enter the SIM card into the slot in the bottom right corner. Please make sure you have the SIM card in the correct direction (chip facing down).

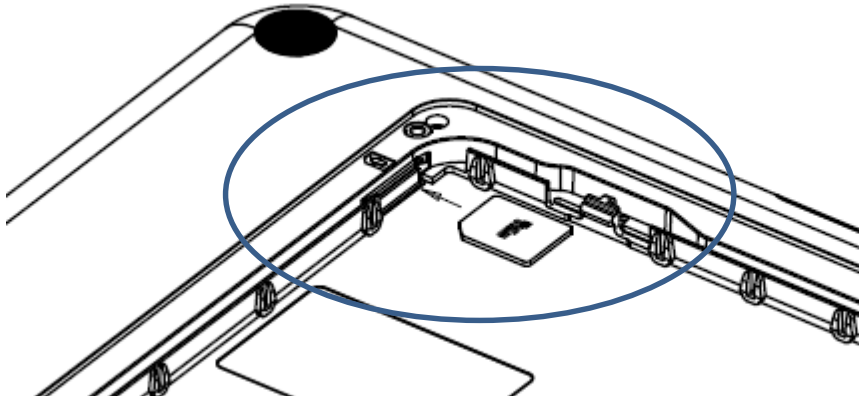

When putting the battery back in place, please make sure both hooks have clicked and are safely secured.

Using the Tablet for the first time

1. Connect power supply for the first time and make sure battery is fully charged before disconnecting.

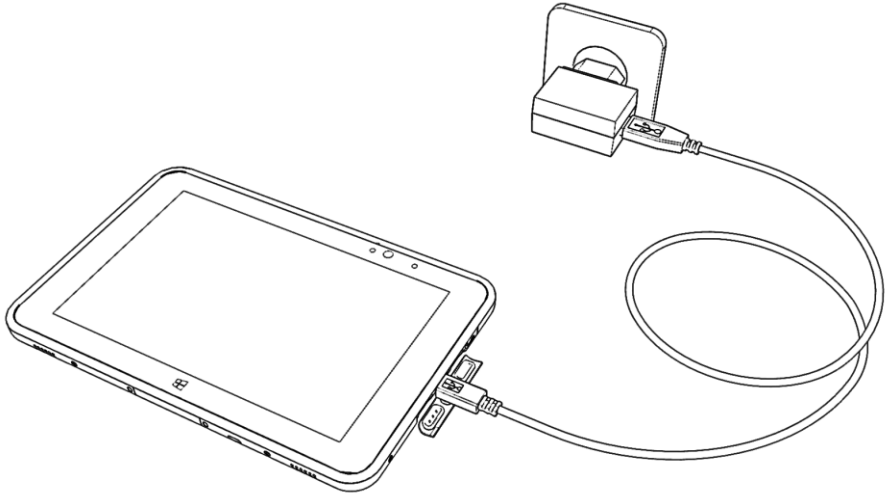

2. Press the power button

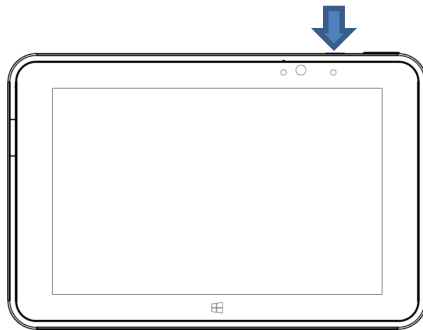

3. Follow the instructions in the operating system to complete the setup

Troubleshooting

In case devices freezes and you need to do a hard reset, press and hold the power button for approx. 14 seconds. Device will be turned off now.

Important Product and Safety information

- Do not drop, bend or twist your tablet. This can break tablet display glass, internal circuit boards or mechanics. If the glass breaks, do not touch the glass parts of the device or attempt to remove the broken glass from the device. Stop using the device until the glass is replaced by qualified service personnel.
- Do not try to disassembly your tablet. This may damage the device.
- Operate your device in a place where temperature is between -10°C and +50°C.
- Store your device in a place where temperature is between -20°C and +60°C.
- Protect your device from water and moisture intake. Keep connector doors closed when not in use to prevent water and moisture intake.
- Listen to a headset at a moderate level, and do not place the device loudspeaker outlets near your ear when the loudspeakers are in use.
- Use only soft, clean and dry lint-free cloth to clean your device.
- Keep the unit and accessories away from small children.
- Switch off your device before boarding to an aircraft.
- Switch off your device in any area with a potentially explosive atmosphere.
- Your device meets guidelines for exposure to radio waves (SAR, Specific Absorption Rate).
- Use only charger delivered with your tablet.
- Do not disconnect charger by pulling the cord.
- Do not use damaged power cords or plugs.
- **Save energy.** You can save energy by doing following.
 - Close unused applications and data connections.
 - Decrease screen brightness and sound volume.
 - Deactivate unnecessary sounds like touch panel sound.
 - Disconnect your charger from mains outlet when charger is not needed.
 - Do not keep unnecessary accessories connected in your device.
- **Recycle.** Return your used electronic units to dedicated collection points. Please note that your tablet has internal battery, so it is not allowed to be disposed to normal household waste.
- **Battery safety**
 - Batteries have life cycles. If the time that the battery powers equipment becomes much shorter than usual, the battery life might be at the end.
 - Stop using the tablet if abnormal heat, order, discoloration, deformation, or abnormal condition is detected during use, charge, or storage.
 - Keep the device away from heat (battery temperature not to exceed 60°C).
 - Do not throw battery into fire, it may be exploded.
 - Do not soak the battery with liquid like water, tea, coffee etc.
 - Do not hit, bend, deform or drop the battery.
 - Do not pierce battery with a sharp object such as a needle, etc.
 - The battery should not have liquid from electrolyte flowing, but in case the electrolyte come into contact with eyes, don't rub your eyes. Wash your eyes well with clean water and go to see a doctor immediately. In case the electrolyte come into contact with your skin, wash it well with clean water.
 - Do not externally short-circuit the battery. If externally short-circuited, the battery may be heated, ignited or broken.

Warning Statements

To prevent possible hearing damage, do not listen at high volume levels for long periods.



WLAN 802.11 a/n bands are allowed for indoor use only.

Federal Communications Commission (FCC) Statement

15.21

You are cautioned that changes or modifications not expressly approved by the part responsible for compliance could void the user's authority to operate the equipment.

15.105(b)

This equipment has been tested and found to comply with the limits for a Class B digital device, pursuant to part 15 of the FCC rules. These limits are designed to provide reasonable protection against harmful interference in a residential installation. This equipment generates, uses and can radiate radio frequency energy and, if not installed and used in accordance with the instructions, may cause harmful interference to radio communications. However, there is no guarantee that interference will not occur in a particular installation. If this equipment does cause harmful interference to radio or television reception, which can be determined by turning the equipment off and on, the user is encouraged to try to correct the interference by one or more of the following measures:

- Reorient or relocate the receiving antenna.
- Increase the separation between the equipment and receiver.
- Connect the equipment into an outlet on a circuit different from that to which the receiver is connected.
- Consult the dealer or an experienced radio/TV technician for help.

This device complies with Part 15 of the FCC Rules. Operation is subject to the following two conditions:

1. this device may not cause harmful interference and
2. this device must accept any interference received, including interference that may cause undesired operation of the device.

Canada, Industry Canada (IC)

Canada, Industrie Canada (IC)

This Class B digital apparatus complies with Canadian ICES-003

Cet appareil numérique de classe B est conforme à la norme NMB-003.

This device complies with Industry Canada licence-exempt RSS standard(s). Operation is subject to the following two conditions: (1) this device may not cause interference, and (2) this device must accept any interference, including interference that may cause undesired operation of the device.

Cet appareil est conforme avec Industrie Canada RSS standard exempts de licence (s). Son fonctionnement est soumis aux deux conditions suivantes: (1) cet appareil ne peut pas provoquer d'interférences et (2) cet appareil doit accepter toute interférence, y compris les interférences pouvant entraîner un mauvais fonctionnement de la appareil.

RSS-210 (Local Area net)

1. The device for operation in the band 5150-5250 MHz is only for indoor use to reduce the potential for harmful interference to co-channel mobile satellite systems;
2. High-power radars are allocated as primary users (i.e. priority users) of the bands 5250-5350 MHz and 5650-5850 MHz and that these radars could cause interference and/or damage to LE-LAN devices.

1.L'appareil pour un fonctionnement dans la bande 5150-5250 MHz est réservé à une utilisation en intérieur pour réduire le risque de brouillage préjudiciable aux systèmes mobiles par satellite co-canal;

2. radars à haute puissance sont désignés comme utilisateurs principaux (à savoir des utilisateurs prioritaires) des bandes 5250-5350 MHz et 5650-5850 MHz et que ces radars pourraient causer des interférences et / ou endommager les périphériques LE-LAN.