

**Draft Version**

***AboCom System, Inc.***  
***Product Specification***

VM310T  
60GHz Gen2 Wireless HD TX Module

Release 0.3

**Date:** Sep 18, 2010

**Author:** Wayne Tseng

**Reviewer** CD Kuo

# Draft Version

## Table of Contents

<b>1.0</b>	<b>REVISION HISTORY</b> .....	<b>3</b>
<b>2.0</b>	<b>RELATED DOCUMENTS</b> .....	<b>3</b>
<b>3.0</b>	<b>INTRODUCTION</b> .....	<b>4</b>
<b>4.0</b>	<b>FEATURES</b> .....	<b>4</b>
<b>5.0</b>	<b>SPECIFICATION</b> .....	<b>7</b>
5.1.	HARDWARE SPECIFICATIONS .....	7
5.2	INTERFACE.....	8
5.2.1	CONTROL I/O .....	8
5.2.2.	POWER CONNECTOR .....	8
5.3.	LED BEHAVIOR .....	9
5.4	RF SPECIFICATIONS .....	9
5.4	BLOCK DIAGRAM .....	10
<b>6.0</b>	<b>PHYSICAL SPECIFICATIONS</b> .....	<b>11</b>
6.1	ENCLOSURE SPECIFICATIONS .....	12
6.1.1	PROPOSED FRONT PANEL AND SIDE CONFIGURATION:.....	12
6.1.2	PROPOSED REAR PANEL CONFIGURATION: .....	12
6.2	POWER REQUIREMENT .....	12

# Draft Version

## 1.0 Revision History

Date	Release	Author	Description
Aug. 5, 2010	0.1	Sandy Chen	Draft version
Sep. 8, 2010	0.2	Wayne Tseng	Modification for FCC submission
Sep. 18, 2010	0.3	Wayne Tseng	Modification for IC & FCC module submission

## 2.0 Related Documents

Date	Author	Document

# Draft Version

## 3.0 Introduction

For coming huge flat TV Screen and high definition resolution, user like to set up the AV system in living room, but the cable placement always be a great harassment to the interior of beautiful house. Also the HDMI cable is as expensive as the length as be. Users deserve to have a wireless cable replacement to match their high class AV systems. Here shows up a high edge solution to meet users' equipment: 60GHz wirelessHD Audio-Video Adapters, VM310T. This elegant and practical product has HDMI interface to take multiple content sources like multimedia center, Blue ray player and Set-Top Box, without compression of content, the WirelessHD technology will offer multiple gigabit throughout for FullHD video transmission. Users do not need to sacrifice video quality for lower transmission bandwidth anymore. VM310T also has compliance to WirelessHD, HDMI and DTCP for content security and quality assurance.

## 4.0 Features

### Input

HDMI X 1

### WIRELESS

Frequency: 60GHz

### Video Format

Video Format	Vertical Refresh	Color Space	Sampling	Bits/Pixel
480i	59.94/60Hz	YCbCr	04:02:02	24/30/36-bits
			04:04:04	24/30/36-bits
		RGB	04:04:04	24/30/36-bits
480p	59.94/60Hz	YCbCr	04:02:02	24/30/36-bits
			04:04:04	24/30/36-bits
		RGB	04:04:04	24/30/36-bits
576i	50Hz	YCbCr	04:02:02	24/30/36-bits
			04:04:04	24/30/36-bits
		RGB	04:04:04	24/30/36-bits
576p	50Hz	YCbCr	04:02:02	24/30/36-bits
		YCbCr	04:04:04	24/30/36-bits
		RGB	04:04:04	24/30/36-bits
720p	50Hz	YCbCr	04:02:02	24/30/36-bits
			04:04:04	24/30/36-bits
		RGB	04:04:04	24/30/36-bits
	59.94/60Hz	YCbCr	04:02:02	24/30/36-bits
			04:04:04	24/30/36-bits
		RGB	04:04:04	24/30/36-bits

## Draft Version

<b>1080i</b>	50Hz	YCbCr	04:02:02	24/30/36-bits	
			04:04:04	24/30/36-bits	
		RGB	04:04:04	24/30/36-bits	
	59.94/60Hz	YCbCr	04:02:02	24/30/36-bits	
			04:04:04	24/30/36-bits	
		RGB	04:04:04	24/30/36-bits	
<b>1080p</b>	23.976/24Hz	YCbCr	04:02:02	24/30/36-bits	
			04:04:04	24/30/36-bits	
		RGB	04:04:04	24/30/36-bits	
	50Hz	YCbCr	04:02:02	24/30/36-bits	
			04:04:04	24/30/36-bits	
		RGB	04:04:04	24/30/36-bits	
	59.94/60Hz	YCbCr	04:02:02	24/30/36-bits	
			04:04:04	24/30/36-bits	
		RGB	04:04:04	24/30/36-bits	
	<b>VGA</b>	60Hz	RGB	04:04:04	24/30/36-bits
	<b>WVGA</b>	60Hz	RGB	04:04:04	24/30/36-bits
	<b>SVGA</b>	60Hz	RGB	04:04:04	24/30/36-bits
<b>XGA</b>	60Hz	RGB	04:04:04	24/30/36-bits	
<b>SXGA</b>	60Hz	RGB	04:04:04	24/30/36-bits	
<b>WSXGA+</b>	60Hz	RGB	04:04:04	24/30/36-bits	
<b>3D Video support list</b>					
<b>Frame packing</b>	1080p@23.98/24Hz				
	720p@50/59.94/60Hz				
<b>Top - Bottom</b>	1080p@23.98/24Hz				
	720p@50/59.94/60Hz				
<b>Side by Side</b>	1080i@50/59.94/60Hz				

\* 1080p at 50/59.94/60 4:4:4 36 bits will be dithered to 24 bits output width

Specification subject to change without notice.

# Draft Version

## Audio Format

Audio up to 8-ch., 24-bit 192 kHz LPCM, surround sound audio (6/8-ch. PCM, Dolby Digital, DTS)

Multiples of Fs	Audio Sample Rate, F's						
	LPCM 2/6/8-channels					LPCM 2-channel	
	DTS & Dolby Digital 2/6 channels						
	32 kHz	44.1 kHz	48 kHz	88.2 kHz	96 kHz	176.4 kHz	192 kHz
128	4.096	5.645	6.144	11.29	12.288	22.579	24.576
256	8.192	11.29	12.288	22.579	24.576	45.158	49.152

Specification subject to change without notice

# Draft Version

## 5.0 Specification

- The column of “Designer Input “is for PM/RD of Product House to fill in, according to its product definition
- The column of “FCS options” is for PM to fill in, according to marketing requirements
- The column of “Note” is for adding comments or clarifications on each feature listed
- Besides specific descriptions, the usable comments for “Designer Input” and “FCS options” are listed as below
  1. “Y” means YES, which this product applies and supports such a feature before FCS
  2. “TBD” means “To Be Discussed”, which it’s negotiable to support a feature before FCS.
  3. “FR” means “Future Released”, which a feature will be supported AFTER FCS.
  4. “TBC” means “To Be Checked”, which is NOT CLEAR if this feature is or will be supported before FCS.
  5. “N” means NO, which this product will NOT support a feature now or future
  6. “N/A” means this feature is not applicable, or not necessarily defined for this product.

### 5.1. Hardware Specifications

<b>VM310 TX</b>			
<b>1. Hardware Features</b>		<b>Designer Input</b>	<b>Note</b>
<b>Processors</b>			
1.1	Primary Processor	AT91SAM7S256MU	
<b>Memory</b>			
1.2	SRAM	64KB	
	FLASH	256KB	
<b>Operating Environment</b>			
1.3	Operating Temp.	0 °C to 40 °C	
	Storage Temp.	-20 °C to 70 °C	
	Operating Humidity	10% to 90% Non-Condensing	
	Storage Humidity	5% to 90% Non-Condensing	
<b>AV Port</b>			
1.4	HDMI	1 Port	
<b>Wireless</b>			
1.5.	WirelessHD 60GHz	32 Antenna Array	Ceramic package
	Range	10 meter NLOS	
<b>Power</b>			
1.6.	Power Consumption	Max: 6.5W, Typ: 5W , Sleep: mode: HDMI source on 1.85W/ HDMI source standby 0.75W	

# Draft Version

## 5.2 Interface

### 5.2.1 Control I/O

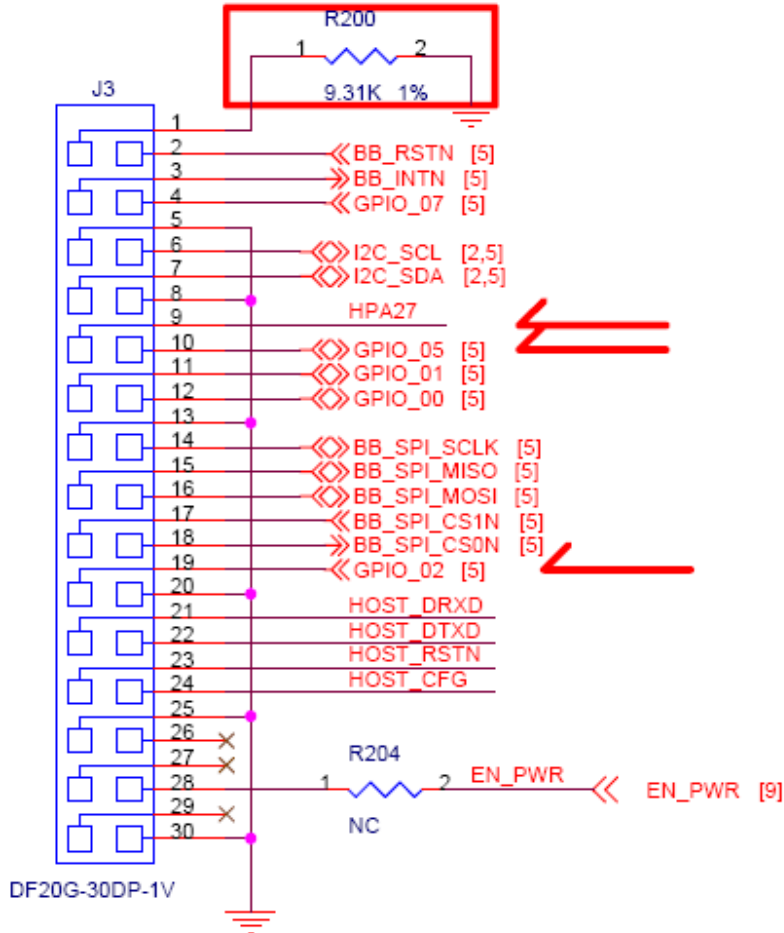

This connector use for manufacture purpose and engineering debug.

Connector P/N: DF20G-30DP-1V of Hirose, PVT and MP model will change to P/N MDS24011P15C of STM

### 5.2.2. Power Connector

4-pin pitch-2.0mm connector onVM311R.

Pin No.	Pin Name	Description
1	GND	Ground
2	VCC 5V	DC 5V
3	VCC 5V	DC 5V
4	GND	Ground

Connector P/N:JS-1125-04(K), GS



# Draft Version

## 5.3. LED Behavior

1.0. LED Behavior				
LED	Printed	Color	Behavior	Indication
Power/Signal	Power	Green	dark/light	Power Off/On
	Link	Green	dark/light	none/Pairing

✘The LED will be flash before TX and RX link

## 5.4 RF Specifications

1. RF Designs		Designer Input	Note
1.1.	Antenna Designs		
	Antenna	32 Antenna Array	
	Antenna Type	Integrate Ceramic	
1.2.	LRP Radiated Power(EIRP)	Maximum 21dBm (Max)	
1.3.	LRP Transmite Antenna Gain	Maximum 13dBi (Max)	
1.4.	HRP Radiated Power(EIRP)	Maximum 27dBm (Max)	
1.5.	HRP Transmite Antenna Gain	Maximum 17dBi (Max)	

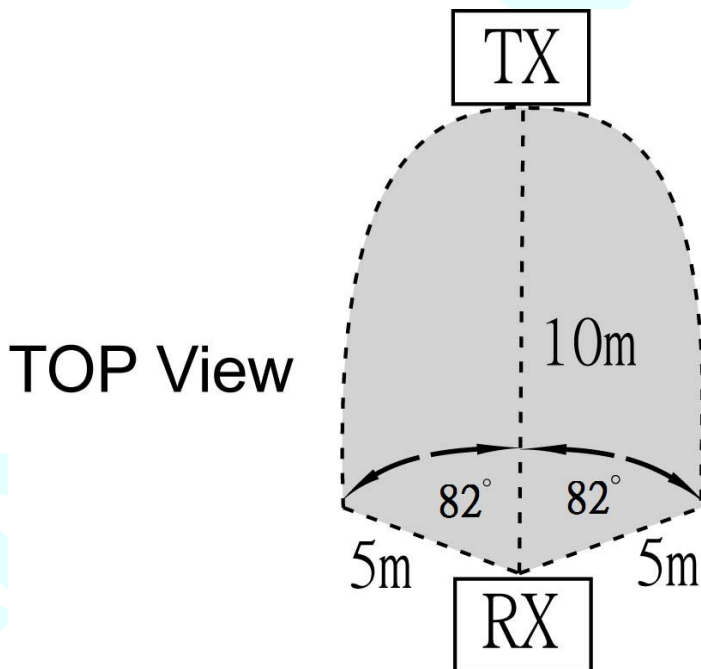

## Draft Version

### Side View

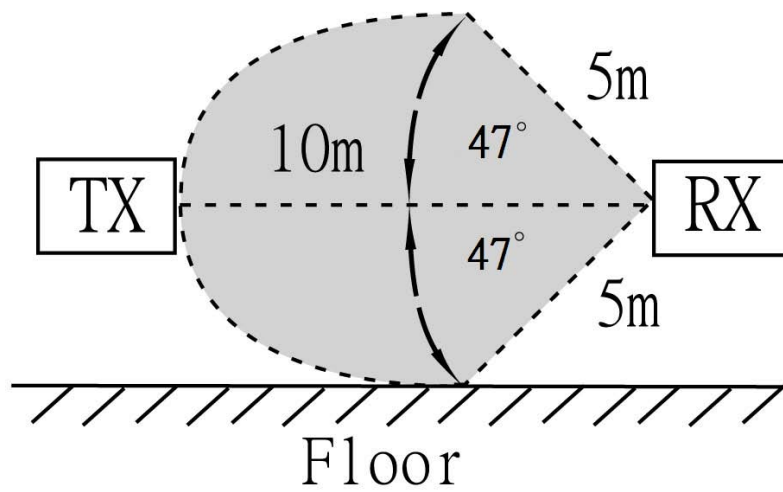

#### 5.4 Block Diagram

### Transmitter

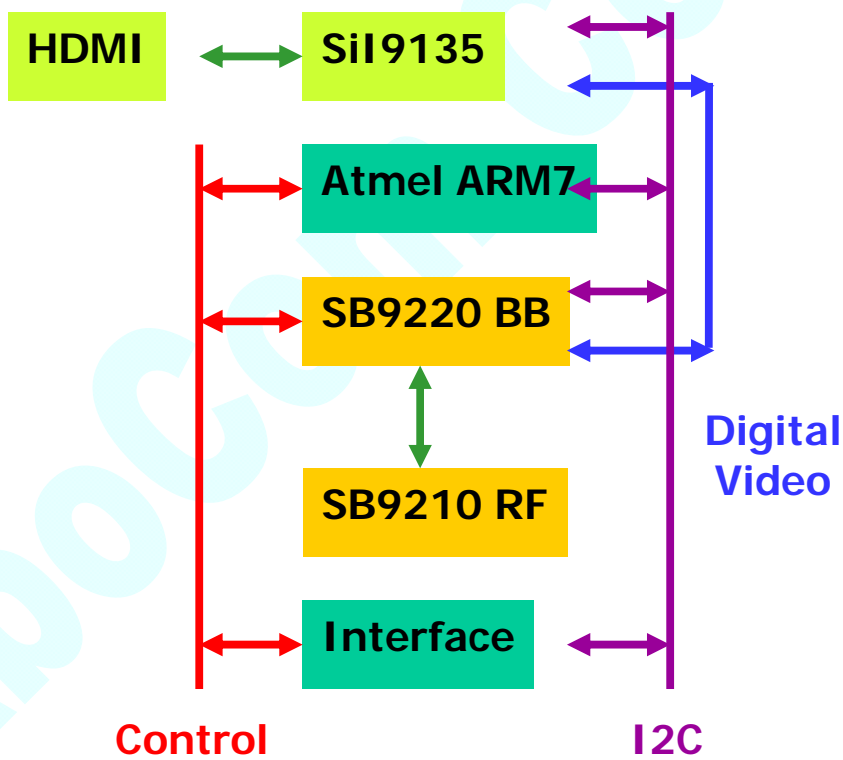

# Draft Version

## 6.0 Physical Specifications

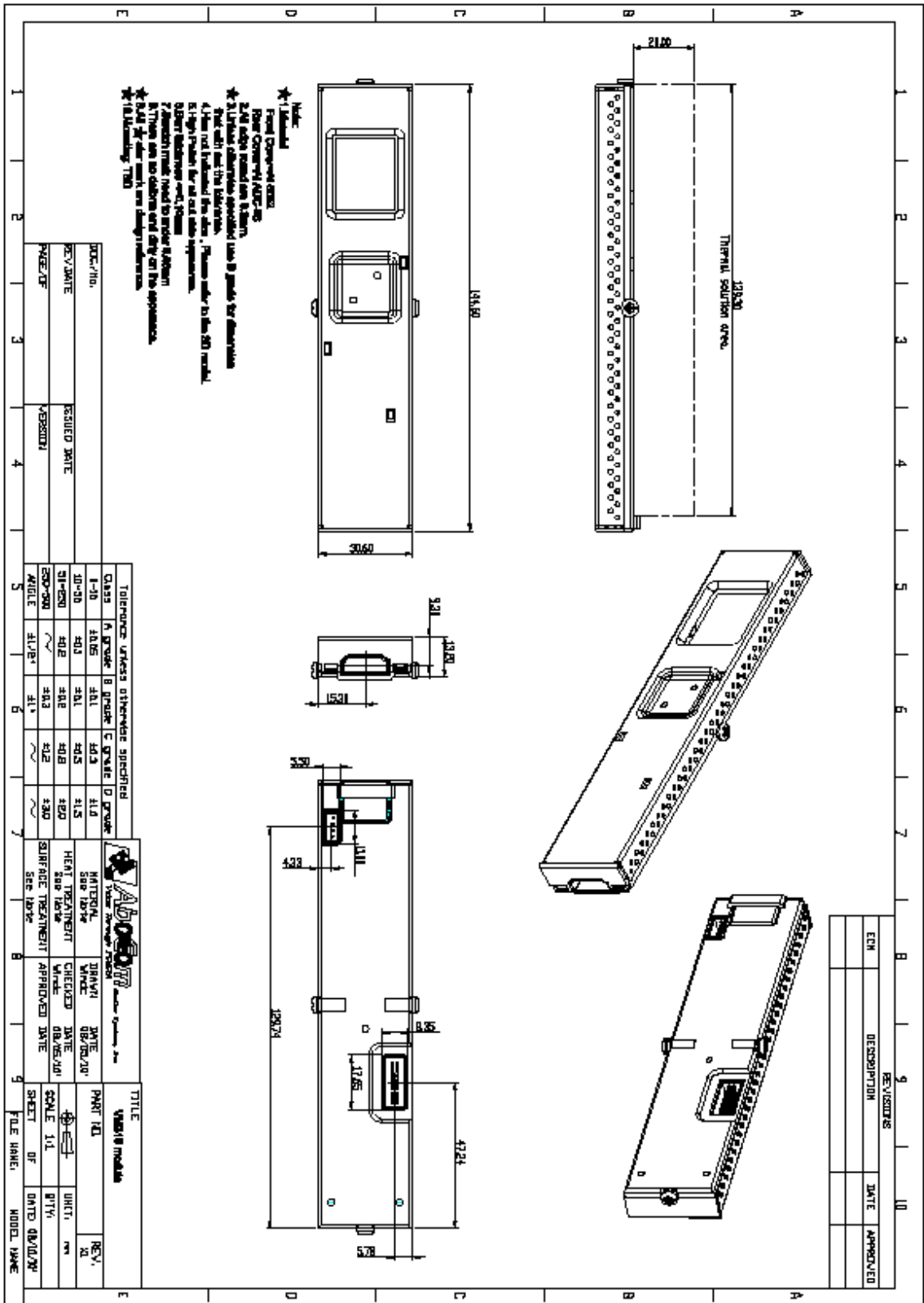

## Draft Version

Provide later

### **6.1 Enclosure Specifications**

Please refer to above page.

#### **6.1.1 Proposed front panel and side configuration:**

1 LEDs display : Power/Link

#### **6.1.2 Proposed rear panel configuration:**

HDMI interface

### **6.2 Power Requirement**

Power input DC 5V 2.0A

# Draft Version

## FCC module Statement:

### IMPORTANT NOTE:

This module is intended for OEM integrator. The OEM integrator is still responsible for the FCC compliance requirement of the end product, which integrates this module.

20cm minimum distance has to be able to be maintained between the antenna and the users for the host this module is integrated into. Under such configuration, the FCC radiation exposure limits set forth for an population/uncontrolled environment can be satisfied.

Any changes or modifications not expressly approved by the manufacturer could void the user's authority to operate this equipment.

### USERS MANUAL OF THE END PRODUCT:

In the users manual of the end product, the end user has to be informed to keep at least 20cm separation with the antenna while this end product is installed and operated. The end user has to be informed that the FCC radio-frequency exposure guidelines for an uncontrolled environment can be satisfied. The end user has to also be informed that any changes or modifications not expressly approved by the manufacturer could void the user's authority to operate this equipment. If the size of the end product is smaller than 8x10cm, then additional FCC part 15.19 statement is required to be available in the users manual: This device complies with Part 15 of FCC rules. Operation is subject to the following two conditions: (1) this device may not cause harmful interference and (2) this device must accept any interference received, including interference that may cause undesired operation.

### LABEL OF THE END PRODUCT:

The final end product must be labeled in a visible area with the following " [Contains TX FCC ID: MQ4-VM310T01](#) ". If the size of the end product is larger than 8x10cm, then the following FCC part 15.19 statement has to also be available on the label: This device complies with Part 15 of FCC rules. Operation is subject to the following two conditions: (1) this device may not cause harmful interference and (2) this device must accept any interference received, including interference that may cause undesired operation.

## IC module Statement:

### IMPORTANT NOTE:

This module is intended for OEM integrator. The OEM integrator is still responsible for the IC compliance requirement of the end product, which integrates this module.

20cm minimum distance has to be able to be maintained between the antenna and the users for the host this module is integrated into. Under such configuration, the IC RSS-102 radiation exposure limits set forth for an population/uncontrolled environment can be satisfied.

Any changes or modifications not expressly approved by the manufacturer could void the user's authority to operate this equipment.

### USERS MANUAL OF THE END PRODUCT:

In the users manual of the end product, the end user has to be informed to keep at least 20cm separation with the antenna while this end product is installed and operated. The end user has to be informed that the IC radio-frequency exposure guidelines for an uncontrolled environment can be satisfied. The end user has to also be informed that any changes or modifications not expressly approved by the manufacturer could void the user's authority to operate this equipment. IC statement is required to be available in the users manual: This Class B digital apparatus complies with Canadian ICES-003. Operation is subject to the following two conditions: (1) this device may not cause harmful interference and (2) this device must accept any interference received, including interference that may cause undesired operation.

### LABEL OF THE END PRODUCT:

The final end product must be labeled in a visible area with the following " [Contains TX IC : 2826B – VM310T01](#) ".

# Draft Version

## Federal Communication Commission Interference Statement

This equipment has been tested and found to comply with the limits for a Class B digital device, pursuant to Part 15 of the FCC Rules. These limits are designed to provide reasonable protection against harmful interference in a residential installation. This equipment generates, uses and can radiate radio frequency energy and, if not installed and used in accordance with the instructions, may cause harmful interference to radio communications. However, there is no guarantee that interference will not occur in a particular installation. If this equipment does cause harmful interference to radio or television reception, which can be determined by turning the equipment off and on, the user is encouraged to try to correct the interference by one of the following measures:

- Reorient or relocate the receiving antenna.
- Increase the separation between the equipment and receiver.
- Connect the equipment into an outlet on a circuit different from that to which the receiver is connected.
- Consult the dealer or an experienced radio/TV technician for help.

This device complies with Part 15 of the FCC Rules. Operation is subject to the following two conditions: (1) This device may not cause harmful interference, and (2) this device must accept any interference received, including interference that may cause undesired operation.

### FCC Caution:

Any changes or modifications not expressly approved by the party responsible for compliance could void the user's authority to operate this equipment.

### FCC Radiation Exposure Statement:

This equipment complies with FCC radiation exposure limits set forth for an uncontrolled environment. This equipment should be installed and operated with minimum distance 20cm between the radiator & your body.

## IC Statement

Operation is subject to the following two conditions: (1) this device may not cause interference, and (2) this device must accept any interference, including interference that may cause undesired operation of the device.

### IC Radiation Exposure Statement:

This equipment complies with IC RSS-102 radiation exposure limits set forth for an uncontrolled environment. This equipment should be installed and operated with minimum distance 20cm between the radiator & your body.