

Acer Leap Ware

User's Manual

© 2017 All Rights Reserved

Acer Leap Ware User's Manual

Model: L05

This revision: May 2017



Acer Liquid Life



Scan to open the
Acer Leap Ware website



go.acer.com/leapware



Download the regulatory
and safety guide (PDF)



go.acer.com/Wearable-Safety-Info

For more information, please visit: <http://go.acer.com/leapware>.



Important

This manual contains proprietary information that is protected by copyright laws. The information contained in this manual is subject to change without notice. Images provided herein are for reference only and may contain information or features that do not apply to your device. Acer Group shall not be liable for technical or editorial errors or omissions contained in this manual.

Acer Leap Ware

Model number: _____

Serial number: _____

Date of purchase: _____

Place of purchase: _____

Google Play is a trademark of Google Inc.

TABLE OF CONTENTS

Leap Ware Quick Tips	4	Viewing the Leaderboard	20
Setting up	5	The Life Page	20
Unpacking your Leap Ware	5	Leap Ware Settings	21
Charging the battery	5	Profile.....	21
Your Acer Leap Ware	6	Device.....	21
Changing the strap	7	Goals and Reminders	22
Care and wearing tips	7	Endurance	23
Pairing the Leap Ware with your phone	9	Tracking your activity and physical condition	24
Download the Acer Liquid Life app	9	Wearing your Leap Ware	24
Set up the app.....	9	Track your physical activity.....	24
Pairing.....	10	Step tracker	24
Sync with the app.....	10	Heart rate measurement.....	25
Using the Leap Ware	11	Blood pressure sensor (not available in all regions)	26
Customizing your Leap Ware.....	11	UV meter.....	27
Navigation.....	11	Running and cycling trackers.....	27
Navigation tips	11	Stamina.....	29
Clock and activity	12	Stress and fatigue.....	30
Notifications	12	Troubleshooting	32
Music.....	12	Specifications	35
Snapshot.....	13	OS.....	35
Stopwatch	13	Display	35
Settings	13	Memory.....	35
UV meter.....	14	Connectivity	35
World Clock.....	14	Sensors.....	35
Flashlight / torch.....	14	Water resistance	35
Reminders	15	Notification	36
Smart notifications	15	Battery	36
Your Acer Liquid Life app	17	System requirements.....	36
Your Profile.....	17	Dimensions	36
My Groups	18	Weight.....	36
Joining a group	18	Certification.....	36
Viewing a group	19	Compatibility	37
Leaving a group	19	End User License Agreement	38
Creating a group	20		

LEAP WARE QUICK TIPS

Here are some quick tips to answer common questions. To get started now please **see Setting up on page 5.**

Setting up

To charge, connect the cable to a USB port on your computer or a certified USB charger (typically 5 V, 1 to 2 A - not included).

The Leap Ware will turn on automatically while charging. Otherwise press and hold the top-left button to turn the Leap Ware on or off.

See Charging the battery on page 5.

Wearing your Leap Ware

Make sure you remove the protective film from the Heart rate sensor before wearing the Leap Ware.

As the LED is on the right-side of the Leap Ware, please wear the device on your left wrist.



See Care and wearing tips on page 7.

Controls

Press the top-left button to display the clock and turn on the backlight.

Press the top-right button to just turn on the backlight.

See Your Acer Leap Ware on page 6.

Leap Ware screens

Swipe up or down to change screens; tap to use (except on the clock face, see below). **See Navigation on page 11.**

- **Clock face** - **see Clock and activity on page 12.**

Swipe left or right to see activity tracking information and controls.

If you accidentally start the Running or Cycling tracker countdown, tap the screen to exit.

- **Notifications** - **see Notifications on page 12.**
- **Music** - **see Music on page 12.**
- **Snapshot** - **see Snapshot on page 13.**
- **Stopwatch** - **see Stopwatch on page 13.**
- **Settings** - **see Settings on page 13.**

Swipe right from Settings to activate *Find My Phone*.

- **UV sensor** - **see UV meter on page 14.**
- **World Clock** - **see World Clock on page 14.**
- **Flashlight / Torch** - **see Flashlight / torch on page 14.**



SETTING UP

Unpacking your Leap Ware

Your new Leap Ware comes packed in a protective box. Carefully unpack the contents of the box. If any of the following items are missing or damaged, contact your dealer immediately:

- Your new Acer Leap Ware device
- Charging cable
- Quick Guide

Charging the battery

For first use, you need to charge your Leap Ware for approximately 150 minutes. After the first full charge, you can charge it as necessary.

1. Attach the USB cable to the Leap Ware, lining up the charging connectors. Ensure the cable is orientated correctly and clicks into place; the cable is held in place with a pair of magnets.

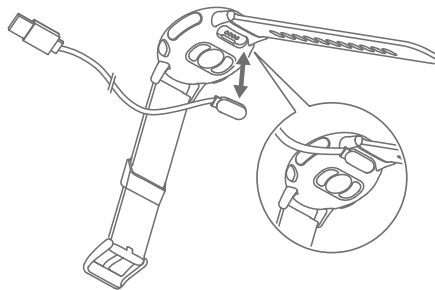

Note

*The Leap Ware will turn on automatically after charging for 15 seconds. For first use, the Leap Ware **must** charge before it will turn on.*

2. Connect the cable to a USB port on your computer or a certified USB charger (typically 5 V, 1 to 2 A - not included).



Note

Use only a charger that complies with national safety standards. Using other chargers may damage the device and risks injury and property damage.

3. The first time you charge your Leap Ware, wait for about 150 minutes to ensure a full charge.

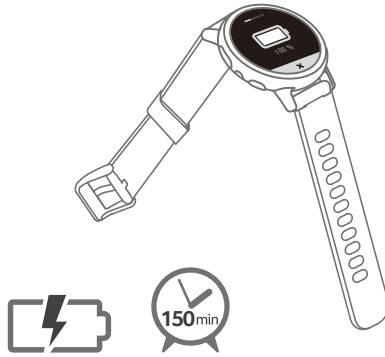

Note

If your Leap Ware has not yet been paired with your phone, the battery gauge is replaced with the Liquid Life download QR code.

Your Acer Leap Ware

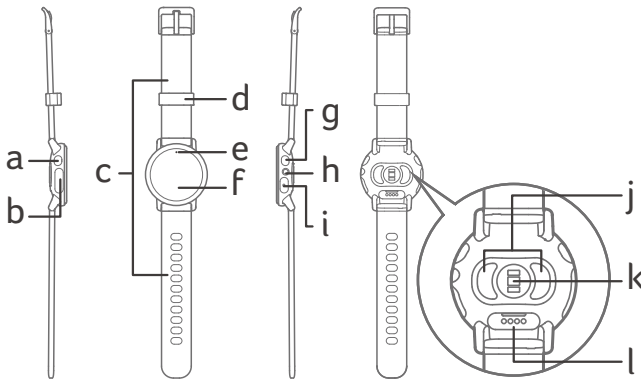

a. Home key

Return to the clock and turn on the backlight

Press and hold: power on / off

(hold for 2-3 seconds to turn on, hold for 8 seconds to turn off)

b. Electrode pad

c. Strap

d. Strap loop

e. UV meter

- f. Touch screen
Tap and hold: turn on the backlight
- g. Quick key
Turn on the backlight
This function may be changed in the Device section of the Liquid Life app
- h. LED
- i. Electrode pad
- j. Electrode pads
- k. Heart rate sensor
Make sure you remove the protective film from this sensor
- l. Charging pins



Changing the strap

You may change the strap attached to the Leap Ware.

Open the spring latch at the top of both straps to remove the old strap.

1. Slide one end of the spring bar of the new strap into the hole in the watch body.
2. Use the latch to retract the pin on the spring bar.
3. Slide the strap into position and release the latch so the strap locks into place.
4. Repeat for the second part of the strap.

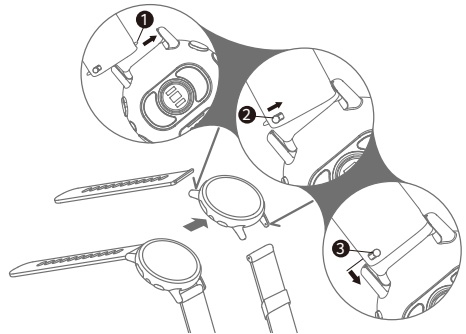

Care and wearing tips

- When using the flashlight, wear the device on your left wrist.
- Position the Leap Ware so the strap is two finger-widths from the base of your palm. The face should be a short distance from your wrist bone (ulna).

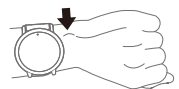

- To improve the accuracy of readings, attach the strap tightly, so the sensors on the underside of the Leap Ware are held firmly against your wrist.
- Readings taken by Leap Ware are to promote a healthy lifestyle, and should not be used or relied on to diagnose any medical condition or symptom.
- Consult your physician before beginning any fitness program.
- Do not submerge the Leap Ware or wear while swimming.
- If you notice any signs of skin irritation or experience any discomfort, please remove or move the Leap Ware until your skin recovers.

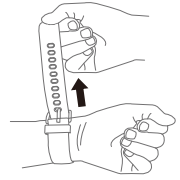

PAIRING THE LEAP WARE WITH YOUR PHONE

Download the Acer Liquid Life app

The *Liquid Life* app gathers data from your Leap Ware and allows you to track activities that promote a healthy lifestyle, display notifications and compare activity with your friends.

Use your phone to scan the appropriate QR code, or open the *Play Store* or *App Store* and search for *Acer Liquid Life*.



Acer Liquid Life



Set up the app

Please install and open the app.

You must create an account, or, if you have used *Liquid Life* before, sign in with an existing *Liquid Life* account.

- Tap *Sign up with your email address* to create a new account linked to your email address.
- If you are a returning *Liquid Life* user and signed up with an email address, tap **Email Address**.
- Or use Facebook or Google+ to sign in.

If this is the first time you have used the app, follow the instructions to create your personal profile.

If you do not want to use *metric* units, tap the *Units* option to change to *Imperial* units.

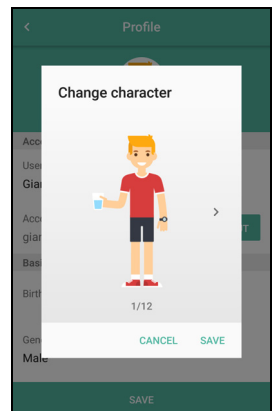

Pairing

After creating your profile, you should see a prompt to pair with the Leap Ware. Make sure the Leap Ware is ON and select **Yes** in the app. Follow the instructions.

- If you are not prompted to pair your Leap Ware, tap the settings icon in the top-left corner of your profile, then tap **Device > Pair**. Follow the instructions.



Note

You must allow the app to access Bluetooth. Your Leap Ware must be paired with the app, not through your phone's Bluetooth settings.

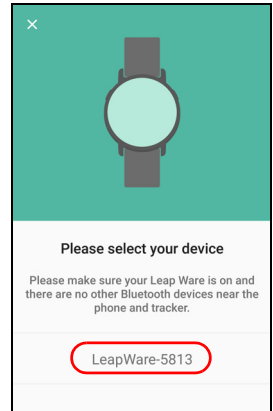

- Tap the name of your Leap Ware in the *Devices found* list (for example *LeapWare-5813*).

After pairing the app will instruct you on how best to wear the Leap Ware and track activities that promote a healthy lifestyle.



Note

For best results, attach the strap so the Leap Ware is held firmly against your wrist.



Note

*Acer does not guarantee that the Liquid Life app or Leap Ware will work with all Android or Apple devices. See **Compatibility on page 37** for a list of tested devices.*

Sync with the app

Your Leap Ware syncs over Bluetooth. Syncing occurs automatically while *Acer Liquid Life* is active, as long as Bluetooth is enabled on your phone.



Note

*If your Leap Ware does not sync correctly with the Liquid Life app, see **My Leap Ware has been disconnected from my phone on page 32**.*

USING THE LEAP WARE

Your Leap Ware will automatically adjust its time and date to match your phone settings. To preserve battery, the screen backlight will turn off after a few seconds.

- To turn the backlight on, tap and hold the screen or press the Home key (top-left key, which will also return to the clock face).
- Scroll through the features of your Leap Ware by swiping left/right, or up/down the screen.
- Tap to select an item.

To return to the main screen from any other screen, press the Home key (left key).

Customizing your Leap Ware

You may customize your Leap Ware from the *Liquid Life* app. [See Leap Ware Settings on page 21.](#)



Navigation

The default main screen shows the time and date.



Note

If the time displayed has not been updated recently, tap the screen to wake the Leap Ware and refresh the screen display.

Swipe up or down to see different Leap Ware functions, or swipe left or right to see activity tracking features.

Navigation tips

Except on the clock screen, you will see small dots at the edge of most screens, either at the top and bottom, or left and right. Swipe towards a dot to switch to the next function.

Tap the screen to open a function, the screen will then provide appropriate controls; tap an icon to use that control, or the back arrow or 'x' to exit.

Clock and activity

The default main screen shows the time and date. Swipe left or right to see activity tracking options.

See **Track your physical activity on page 24**.



Note

To save energy, the clock will not refresh if your Leap Ware detects no activity for a while. Simply tap the screen to refresh the display.

Notifications

Swipe up to see if you have received any messages.

Tap to see a list of unread messages and missed call notifications. See **Smart notifications on page 15**.

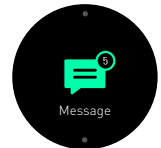

Music

Swipe up again and tap to open the music remote control.

If a compatible music app is open on your phone, tap the control symbols to control playback. Tap the volume symbol to open the volume control. Tap the return arrow to exit.

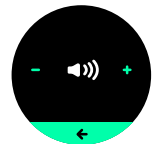
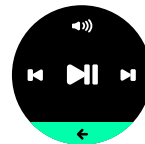
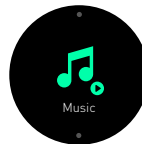

Note

Acer does not guarantee that the Music remote control will work with all Android or Apple devices.

Snapshot

Swipe up again and tap to open the camera shutter remote control.

If a compatible camera app is open on your phone, you can tap the circle to take a photo. Tap the arrow to exit.

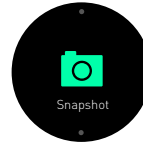

Note

Acer does not guarantee that Snapshot will work with all Android or Apple devices.

Stopwatch

Swipe up again and tap to open the stopwatch.

Tap the *Play* button at the top of the screen to start the stopwatch, and tap the *Pause* button to stop the timer; press *Play* to restart, or *Stop* to clear the time. Tap the **X** to exit.

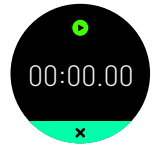

Settings

Swipe up again and tap to open Settings.

The first screen shows the battery level, swipe left or right to see: device information (including regulatory information), factory reset, or *Find My Phone*.



Find My Phone

Open the *Settings* screen then swipe right. Tap the **Find My Phone** icon to sound an alarm on your phone (your phone must be within Bluetooth range). After you have located your phone, tap **Dismiss** on your phone to stop the alarm.

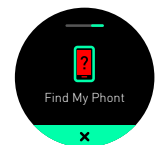

An alert will be shown if the phone is out of Bluetooth range (or otherwise not connected, i.e. powered off or Bluetooth is off).

UV meter

Swipe up again to start the UV meter.

The UV meter will measure the ambient UV intensity and displays a rating indicating UV intensity, from low to high.



Note

Do not block the sensor (above the touchscreen) while it is active.

World Clock

Swipe up again and tap to see the World Clock.

This screen shows the time in the time zone set by the *Liquid Life* app.

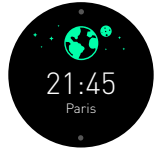

Note

*To change the World Clock zone, in the Liquid Life app, tap the Settings icon then the name of your Leap Ware under Device. Finally select **World Clock** then an appropriate city / time zone from the list.*

Flashlight / torch

Swipe up again and tap to see the flashlight / torch controls for the LED on the right side of the Leap Ware.

- Tap SOS to blink the morse code for 'SOS'.
- Tap the middle icon to turn the LED on.
- Tap the right-side icon to flash the LED repeatedly.

Tap the icon again to turn off the LED.



Note

As the LED is on the right-side of the Leap Ware, please wear the device on your left wrist, or remove the device temporarily.

Reminders

If you have set up reminders for water, weight, or medicine, your Leap Ware will vibrate and display a reminder.



If the reminder is a measurement (water or weight), you may update these directly from your Leap Ware. Tap the - or + symbols to change the value, then tap the check mark to update the value.

Smart notifications

Your Leap Ware will vibrate and display notifications if *Smart notifications* are on in the Liquid Life app.

Steps & Calories: Receive notifications when you reach certain milestones.

Goal achieved: Receive a notification when you reach a goal set in the Liquid Life app.



Note

To set goals and reminders, and change Phone notifications, open the Liquid Life app, then tap the Settings icon. Scroll down to the Goal and Reminders section and tap the entry you want to use.

Eye Care: Regular reminders to take a break if viewing a screen.

- If the smartphone screen is on continuously for 30 minutes, your smartphone will display an eye care notification.
- A second notification will be displayed after an hour. If you dismiss this notification then you will not see another.

App notifications: Display messages or notifications from a selection of compatible apps installed on your phone.



Note

*To change which apps generate notifications, in the Liquid Life app, tap the Settings icon then the name of your Leap Ware under Device. Select **Notifications** then tap to turn notifications from each app on or off.*



Important

You will only receive notifications if your phone and Leap Ware are turned on and connected.

Notifications are received in real time; meaning you will only get notifications for messages and calls received while the Leap Ware and smartphone are 1) within range of each other, 2) turned on, and 3) connected via Bluetooth.

If the Leap Ware and are disconnected, then reconnected, stored notifications will be lost.

YOUR ACER LIQUID LIFE APP

Your Profile

The *Profile* screen shows your character image, current status and tracks your progress towards goals.

Labels around your character image show your water consumption, stress level, heart rate, weight, UV reading and activity (steps). An additional label shows the UV forecast for your location.

Tap these labels to see more information, such as a Daily / Weekly / Monthly record. For example, tap the *Heart rate* label to see a history of heart rate readings (and also blood pressure information - not available in all regions).

At the top of the screen three icons allow you to open the Settings screen, Endurance level and tasks, and to share your profile as an image.

Tap the + icon in the bottom-right corner to update water intake or your weight.

Swipe left or right to see *My Groups* (page 18) or the *Life Page* (page 20).



Note

Using your phone's sensors, the Liquid Life app can continue to track your steps even when not paired to the Leap Ware. However, the step count may be less accurate.

My Groups

Swipe left from the *Profile* screen to open the *My Groups* screen.

My Groups allows you to create up to three groups to compare progress, or compete, with your friends or rivals. Each group may contain up to ten members and shares your profile information with access to a weekly or monthly activity leaderboard.

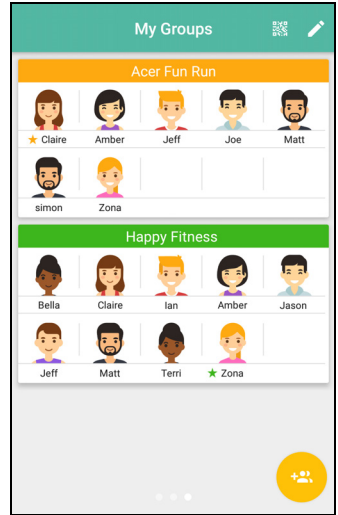

Joining a group

If a friend with the *Liquid Life* app has set up a group and has their phone, simply open the *My Groups* screen in your *Liquid Life* app and tap the QR code icon at the top of the screen.

The group creator must then open the group in their *Liquid Life* app and tap **Add** at the bottom of the screen, then **By QR code**. They may then scan the code on your phone's screen.

If the groups creator is not present, and you used your email address to create your account, they can add you by selecting **By Account**. They may enter your email address and tap **Search**.

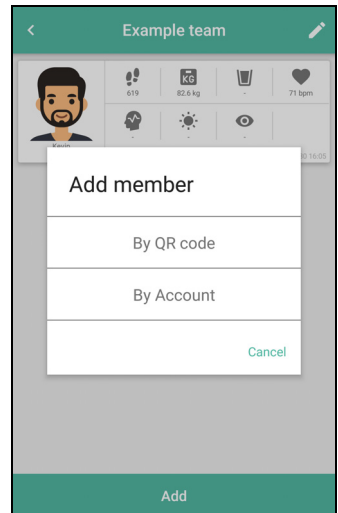

Note

You may not join more than three groups in the free Liquid Life app.

Viewing a group

After joining or creating a group, you will see a group summary with ten slots in the *My Groups* screen. The summary shows the character icon and name of each member.



Note

A star is shown next to the name of the group owner/creator.

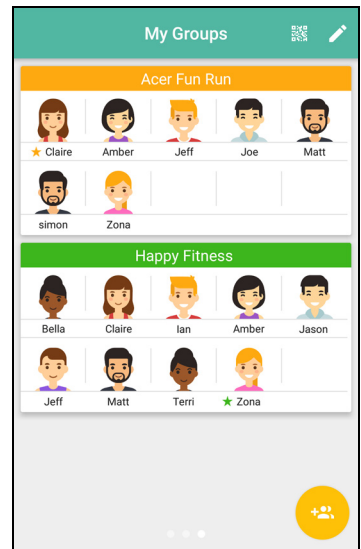

Tap on the group to see more information. A tile for each member shows the shared information. If there are more than four members, swipe up or down to see tiles for all the members of the group.



Note

The group owner/creator may select which information is shown. This is done when the group is created, or may be changed by opening the group and tapping the edit icon.

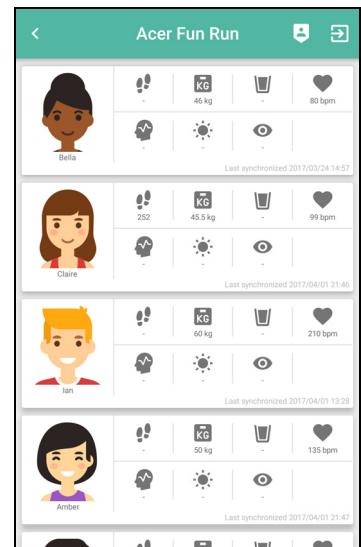

Leaving a group

You may leave a group at any time. Open the group and tap the *Exit* icon, then select **Delete**.

A group owner/creator may also remove members. Open a group you created, and tap the *Edit* icon; tap the *Delete* icon next to the name of the member to be removed.

Creating a group

You may create your own group and ask friends to join.

Tap the *Add group* icon in the bottom-right corner of the *My Group* screen and enter a descriptive name for the group. All members will see this name.



You may then choose which information will be shared in the group (Steps, Weight, Water, Heart rate, Stress, UV, and Eye Strain). Tap on each item to select it - selected items will be outlined. Tap **OK** to create the group.

You may now ask friends with the *Liquid Life* app to join your group, using either their account email address, or by scanning a QR code displayed on their phone.

Viewing the Leaderboard

You may view a weekly or monthly activity leaderboard for each group. Top-ranked group members will be shown on a track, with the relative distance covered represented by the position of each character image. Below the track a list shows all members, ranked by total steps taken over the selected period.



The Life Page

Swipe right from the *Profile* screen to open the *Life Page* screen.

The *Life Page* shows a selection of health, lifestyle and well-being stories that may help, inform or inspire you.

The *News* tab shows articles you may read taken from a variety of sources. The *Video* tab provides video articles for well-being.

Tap the *Bookmark* icon to save an item for future reference; your bookmark choices will be used to customise the lists to better match your interests. Tap the *Share* icon to send the item to another app.

Tap the *Menu* icon, then select **Bookmarks** to see your bookmarked articles.

Leap Ware Settings

You may customize your Leap Ware from the Liquid Life app. Tap the **Settings** icon in the top-left corner of the main screen.

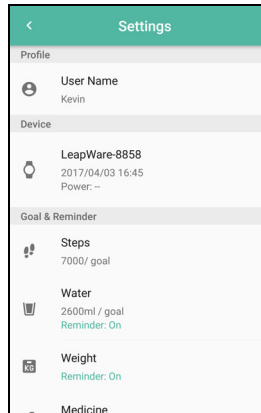

Profile

Tap your User Name to access your profile.

Adjust your profile here, including your character image, account and basic physical information. You may also set base, or typical, systolic and diastolic blood pressures (not available in all regions).



Device

Tap the name of your Leap Ware under the *Device* section, you may then tap a section to adjust you phone's behavior.

You may change:

- Clock Face
Choose a new look for the clock face on the main screen.
- World Clock
Choose a time zone to show in the World Clock page.
- Quick Key
Adjust the function of the Quick Key.



- **Theme**
Choose the highlight color for Leap Ware graphics.
- **Notifications**
Choose which apps will generate a notification on your Leap Ware (only available for certain apps).
- **User Manual**
Download a copy of the User's Manual.
- **Firmware version**
Shows the version of the firmware installed on the Leap Ware. Tap to check you are using the latest version.
- **Serial Number**
Shows the serial number of your Leap Ware. This may be needed if you contact the Acer service center.

Goals and Reminders

Set your goals and reminders in this section.

Your goals are visible on the main profile page. The initial values are determined from the information entered in your profile, but you may adjust the values for a more, or less, challenging routine, or to more accurately reflect your personal constraints and advice from health or training professionals.



You may adjust your daily:

- Targets for steps during the day.
- Target for water intake.
- Reminders to check your weight or take medicine.



You may also change *Smart notifications*, which can alert you as you increase your steps, achieve goals, or reminders to take care of your eyes by not looking at a screen for too long. See [Smart notifications on page 15](#).

Endurance

The Liquid Life app provides an estimation of your Endurance and Stamina 'level'.

Tap the *Level* icon on the profile screen. The *Endurance* screen shows your current level with a badge and level title.



To provide a base level, you must determine your resting heart rate. Tap the button at the bottom of the screen to see instructions on how to assess the base rate. Make sure you rest for several minutes and sit calmly before performing this process.

After your resting heart rate has been recorded, whenever you run for more than 20 minutes the app will assess your performance (based on your heart rate) and determine your level.

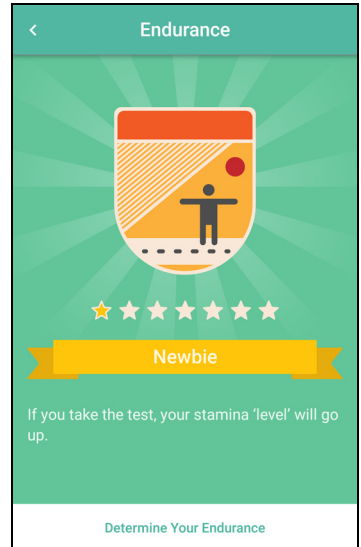

Note

While running, keep your phone with you, with an active data connection, so the Leap Ware can continuously transmit information to the app and provide assessments.



Note

*For an accurate assessment, periodically update your resting heart rate information: from the Profile screen, tap **Heart Rate**, then tap the arrow in the Resting HR section. Follow the instructions.*

TRACKING YOUR ACTIVITY AND PHYSICAL CONDITION

Your Leap Ware can track your activity and with the Liquid Life app you can follow trends in your physical condition.

Wearing your Leap Ware

To obtain consistent results, your Leap Ware must be able to take good readings from a consistent position on your wrist. For more information, see [Care and wearing tips on page 7](#).

- For a small set of users, the Leap Ware will be unable to take measurements. See [Heart rate measurement on page 25](#) for more information.

Track your physical activity

The default main screen shows the time and date. Swipe left or right to see activity tracking options.

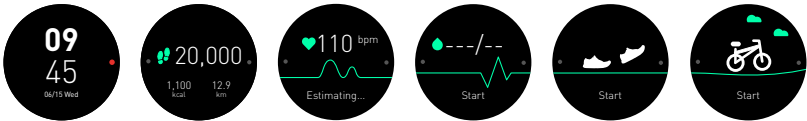

- Step tracker (steps / calories / distance).
- Heart rate sensor
- Blood pressure sensor (not available in all regions)
- Running tracker
- Cycling tracker

Step tracker

The three values indicate the how many steps you have taken during the day, how many calories this represents and the estimated distance covered by these steps.

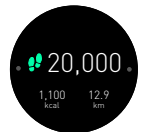



Note

Tap the screen to change which of the readings are shown in the center of the screen.

If you reach the goal set in the Liquid Life app, the Leap Ware will display a notification.

The reading resets at midnight and are stored by the Liquid Life app so you may track trends in your lifestyle.



Heart rate measurement

The Leap Ware will automatically estimate your heart rate when you switch to the heart rate screen. After it has finished, tap **Start** to estimate again.

The Leap Ware also estimates your heart rate every 60 minutes to provide a record you may view in the Liquid Life app; when you perform stamina tests; and when using the running or cycling tracker.



What is your heart rate?

Your heart rate, or pulse counts the number of times your heart beats per minute. Normal heart rate varies from person to person and varies according to your current activity and physical condition.

Heart rate measurement

The Leap Ware flashes an LED many times per second and measures reflected light to detect the flow of blood at any given moment. Each heart beat changes the flow of blood and these changes are used to calculate your heart rate.

Make sure you are wearing the Leap Ware correctly to get the best measurements. See **Wearing your Leap Ware on page 24**.

- For best results relax your wrist and stay still for 10-15 seconds.
- High-intensity training will increase your heart rate and may cause erratic readings. Please rest before taking measurements.

Results may vary for many reasons, including:

- Sharp, erratic movements, such as high-intensity training.
- Skin thickness and condition, and overall wrist thickness.

- Cold weather will reduce the effectiveness of the heart rate sensor.
- A tattoo or other skin covering can block light from the sensor.

Blood pressure sensor (not available in all regions)

Swipe to the blood pressure screen to estimate your blood pressure.

Before you tap start, sit and relax for a couple of minutes. Place the sensors on either side of the Leap Ware between your first and second fingers.

Make sure there is good, but not tight, contact (do not squeeze) between the inside of your fingers and the sensors. Do not tense your muscles; keep your arm, hand and fingers relaxed.



What is blood pressure?

As your heart beats, it pumps blood around your body to transport, amongst other things, energy and oxygen. As the blood moves, it pushes against the sides of the blood vessels.

Blood pressure measurement

Blood pressure measures two quantities; the higher value approximates the pressure needed on an artery to stop the flow of blood, and the lower value the pressure at which the flow of blood is no longer detectable. These values may indicate the condition of your blood vessels.

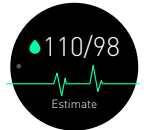

If the arterial walls are tense and hard, blood flow travels faster and at a higher pressure. If the arterial walls have less tension blood travels more slowly and at a lower pressure.

The Leap Ware electrodes measure Pulse Transit Time (PTT); the time it takes for a pressure wave to travel from the heart to a peripheral part of the body. This pressure wave travels faster if blood pressure is high and slower if blood pressure is low.



Note

Readings taken by Leap Ware are to promote a healthy lifestyle, and should not be used or relied on to diagnose any medical condition or symptom. Consult a training coach before beginning any fitness program.

UV meter

What is UV meter?

The UV meter detects the intensity of ambient ultraviolet (UV) light. Prolonged exposure can damage your skin.

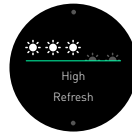

Estimating UV

The UV meter uses photodiodes to estimate ambient UV light. This adjusts automatically to differentiate between indoor or outdoor lighting.

Detected UV levels are rated from *Low* to *Extreme*, rated from one to five sun icons. As the rating increases, take more precautions to protect yourself from the sun's rays, such as using sunscreen or staying in shade, especially in the middle of the day.

Running and cycling trackers

The Leap Ware shows the real-time stamina while exercising, and tells you when you reach the fat-burn zone based on your heart rate. This gives you more understanding of your pace.

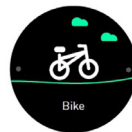

When you are ready to exercise, swipe to either the running or cycling screen, and tap. You will see a countdown before the main tracker starts.





Note

Keep your phone with you so the Leap Ware can continuously transmit information to the app.
If you accidentally start the countdown, immediately tap the screen to exit.

You will see a screen showing the distance covered, duration and your heart rate.



Note

Tap the screen to change which of the readings are shown in the center of the screen.

To rest, tap the *pause* icon at the top of the screen, then the play icon to start again.

To exit the tracker, tap *pause*, then *stop*. The Leap Ware will ask you how you feel about your breathing and overall energy; select *thumbs up* (good), *neutral* or *thumbs down* (bad).



Note

If you do not have your phone, or it is not connected to the Leap Ware, you will not see these questions.

Real-time stamina

You Leap Ware lets you know how your workout is going. Stamina, heart rate, workout duration/distance, and calories burned can be displayed in real-time for more effective work out sessions.



Note

If you do not have your phone, or it is not connected to the Leap Ware, the outer circle will be grey and the real-time stamina countdown will not be available.

Exercise mode determines your *Fat Burn* zone from your profile information and current heart rate. See **Estimating Stamina on page 30**.

See your activity in the *Liquid Life* app

After you have finished your workout. You can open the *Liquid Life* app to see your activity.

Tap the *Activity* label. Your daily activity shows three tracks: steps, running and cycling. Your avatar shows the relative distance covered by each activity.

Scroll down and tap the **Distance** line to see a break down of each activity.

Tap **Weekly** or **Monthly** at the top of the screen to see a graph of your overall activity over a longer period - swipe left or right on the graph to change the time period displayed.

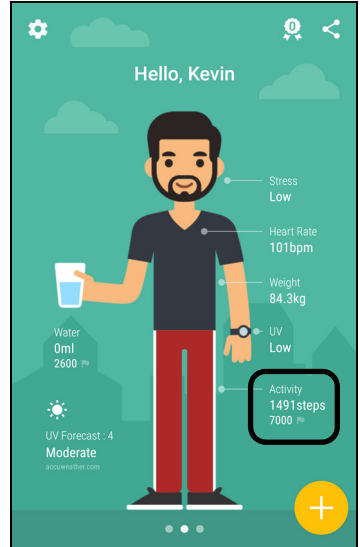

Calories burned

The *Liquid Life* app estimates how many calories you have burned and how much food that represents. Tap on the food icon to change the food type; choose from *Soft Serve* ice-cream, bottles of *Cola*, servings of *Popcorn*, or *Hamburgers*.

Stamina

What is stamina?

Stamina in this context represents the amount of energy required to sustain a high intensity workout. Stamina will recover if you take a break for a while or have an additional energy supply.

Stamina theory

When exercising, two types of energy systems are used: aerobic and anaerobic. Stamina represents a combination of aerobic and

anaerobic energy systems. In a low-intensity workout, aerobic systems provide energy. In contrast, in a high-intensity workout, energy is supplemented by the faster anaerobic system.

Understanding how your body uses these two systems allows you to perform better in endurance exercises.

Estimating Stamina

The 'Stamina' rating is based on information in your profile, such as gender, age, height and weight, with additional reference to daily step and heart rate measurements. While you are exercising, the green border around the Leap Ware screen indicates your current Stamina - a full green arc means your Stamina is at 100% and as your Stamina is used, the arc will gradually disappear.



Stress and fatigue

What is Stress?

Stress is a reaction to physical, mental or emotional stimulus. It is not always a bad influence, but it can interfere with your health or physical state (for example: heart rate).

Fatigue can be a symptom of long-term stress, defined as physical or mental exhaustion. Fatigue dulls your senses, thought processes and reflexes.

Stress theory

Stress/Fatigue can be measured by following variations in heart rate. This is calculated based on variations of time between two heart beats.

The Leap Ware will periodically assess the variation of time between two heart beats and display an alert if stress is detected.

Low heart rate variability indicates you are under high stress, while a higher heart rate variability indicates lower stress.

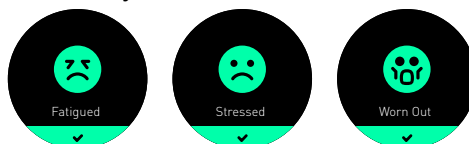

You may also check your current stress level on the profile screen in the *Liquid Life* app. Additionally, tap the **Stress** label to see recorded stress levels since you started wearing the Leap Ware.



TROUBLESHOOTING

I can't connect my Leap Ware to my phone

A *disconnected* icon is shown in the Liquid Leap app if the Leap Ware is not connected.



Try closing *Acer Liquid Life* and turning off your Bluetooth connection. Launch *Acer Liquid Life* and turn Bluetooth on again.

My Leap Ware has been disconnected from my phone

If your Leap Ware does not sync correctly with the Liquid Life app, please stop and restart Bluetooth on your device or restart your phone.

Alternatively, restart the app (in your phone's **Settings** > **Apps** > **Acer Liquid Life** > **Force stop**, then open the app).

If your Leap Ware is still disconnected, unpair the Leap Ware using *Acer Liquid Life* (in **Settings** > **Device**) and pair the devices again. See [Pairing the Leap Ware with your phone on page 9](#).



Warning

If you unpair and pair your devices, you will lose data stored on the Leap Ware.

I can't control music playback

Try launching your device's music player and start playing a song. Now you should be able to control the music playback from the Leap Ware.

The Leap Ware will control apps that are compatible with basic music control standards.

I can't control my camera

After setting up, the Snapshot function does not work on some Android phones. If this is the case, please follow these steps to activate Snapshot.

1. Pair the Leap Ware with Liquid life.
2. Open **Settings** on your phone.
3. Open **Bluetooth** settings.

4. In the *Available device list*, find the Leap Ware name in the list ("Leap Wear-xxxx" where xxxx = number).
5. Tap the Leap Ware name and make sure it is *Paired*.
6. The *Snapshot* function should now work.

My Leap Ware has turned off

Your Leap Ware will automatically turn off if the battery level drops to about 1%, try charging it for at least 15 minutes before using it again.

Your Leap Ware will also turn off if the battery overheats. If your Leap Ware is unusually warm, allow it to cool before charging it. If the Leap Ware repeatedly overheats, please contact an authorized Acer service center.

How do I wake my Leap Ware up?

If you are having trouble waking your Leap Ware up, try charging it.

If it has been fully charged or still has power, tap the screen or press the Home key.

My Leap Ware won't turn on

Try charging your Leap Ware. It should turn on after a few minutes of charging.

If this doesn't help, please contact an authorized Acer service center.

My Leap Ware won't pair

Please make sure your smartphone's Bluetooth is enabled from your smartphone's Bluetooth settings. If you have just enabled Bluetooth, remove *Acer Liquid Life* from recent apps and launch it again.

If *Acer Liquid Life* says it cannot find your Leap Ware, please go to your smartphone's Bluetooth settings and look at the connected devices. You should see a device name starting with LeapWare. If it says *connected*, tap and hold the device name (or in iOS tap the (i) icon) and select **Forget this device** or **delete**. Return to *Acer Liquid Life* and connect again.

How do I remove the Leap Ware from my account?

Open *Acer Liquid Life*, open *Settings* and tap **Device**. You will see an *Unpair* button; tap to unpair your Leap Ware.

To pair a new device, see **Pairing the Leap Ware with your phone on page 9**.

How do I update my Leap Ware?

From time to time, there may be updates available for your Leap Ware. When you pair your Leap Ware with a phone, it will check for and apply updates.

If an update is available, you will receive an update notification and your Leap Ware will automatically update when it syncs with the app. Ensure your smartphone and Leap Ware are sufficiently charged.

SPECIFICATIONS

OS

Proprietary OS

Display

1.1" LCD transfective touchscreen

218 x 218 resolution (round)

Capacitive touch

64-color with backlight

Memory

4 MB flash

4 MB SRAM

Connectivity

Bluetooth 4.0 LE

Sensors

Three-dimensional accelerometer

UV meter

PPG and ECG

Water resistance

Water resistant (IPX7)



Note

Do not submerge or wear while swimming.

Notification

Vibration

Battery

130 mAh rechargeable, non-user replaceable battery

Up to 5-days battery life

Charging via Pogo pins (USB)



Note

Battery life changes depending on use.

System requirements

Android 5.0 or higher

iOS 8.0 or higher

Bluetooth 4.0 (BLE)

Acer Liquid Life app

Dimensions

42 x 42 x 12.2 mm (without strap and strap attachments)

Weight

37 g

Certification

To view safety and regulatory information, open **Settings** on the device, swipe to **Device info**, tap then swipe left or right.

COMPATIBILITY

ACER

Liquid Z6 Plus

ASUS

ZenFone 2 Deluxe(ZE551ML) 4G/64GB

ZenFone Selfie ZD551KL 16GB

ZenFone 2 Laser (ZE601KL)

Zenfone GO ZC500TG

ZenFone 2 Laser ZE550KL 16GB

ZenFone 3 ZE552KL (4G/64GB)

HTC

Butterfly S

One max 803s

One E9 dual sim

Desire 728 dual sim

ONE M9+

One (M8)

ONE X9 dual sim

One A9

Butterfly 3

Desire 530

10 (M10h)

Desire 826

HUAWEI

G7 Plus

P9 32GB

GOOGLE Nexus 6P

LG

G3 16GB (D855)

G4 32GB (H815)

V10 (LG-H962)

K10

G5 (LG-H860)

MEIZU

Pro 5

OnePlus

2 (A2001)

SAMSUNG

GALAXY S6 edge+

GALAXY S5 (SM-G900I)

Galaxy A8

Galaxy Note 5

SONY

XPERIA Z2 (D6503)

XPERIA X Compact

XIAOMI

Mi 4i

Mi-4c

ZTE

Blade S6 Plus

BLADE V580

APPLE

iPhone 7 (32GB)

iPhone 5C (MF321TA/A) (A1529)

iPhone 6 Plus

iPhone 6S (16GB)

iPhone 5s (16GB)

iPhone 5

END USER LICENSE AGREEMENT

IMPORTANT-READ CAREFULLY: THIS END USER LICENSE AGREEMENT ("AGREEMENT") IS A LEGAL AGREEMENT BETWEEN YOU (EITHER AN INDIVIDUAL OR A SINGLE ENTITY), AND ACER INC. INCLUDING ITS SUBSIDIARIES ("ACER") FOR THE SOFTWARE (WHETHER PROVIDED BY ACER OR BY ACER'S LICENSORS OR SUPPLIERS) THAT ACCOMPANIES THIS AGREEMENT, INCLUDING ANY ASSOCIATED MEDIA, PRINTED MATERIALS AND RELATED USER ELECTRONIC DOCUMENTATION WHICH MAY BE BRANDED "ACER" ("SOFTWARE"). AGREEMENTS RELATING TO ANY OTHER PRODUCT OR TOPIC ARE NEITHER INTENDED NOR SHOULD THEY BE IMPLIED. BY INSTALLING THE ACCOMPANYING SOFTWARE OR ANY PORTION THEREOF, YOU AGREE TO BE BOUND BY THE TERMS AND CONDITIONS OF THIS AGREEMENT. IF YOU DO NOT AGREE TO ALL OF THE TERMS AND CONDITIONS OF THIS AGREEMENT, DO NOT CONTINUE THE INSTALLATION PROCESS AND IMMEDIATELY DELETE ALL INSTALLED FILES, IF ANY, OF THE ACCOMPANYING SOFTWARE FROM YOUR PHONE.

IF YOU DO NOT HAVE A VALIDLY-LICENSED COPY OF THE APPLICABLE SOFTWARE, YOU ARE NOT AUTHORIZED TO INSTALL, COPY OR OTHERWISE USE THE SOFTWARE, AND HAVE NO RIGHTS UNDER THIS AGREEMENT.

The Software is protected by U.S. and international copyright laws and conventions as well as other intellectual property laws and treaties. The Software is licensed, not sold.

GRANT OF LICENSE

Acer grants to you the following non-exclusive and non-transferable rights with respect to the Software. Under this Agreement, you may:

1. Install and use the Software only on a single designated phone. A separate license is required for each phone on which the Software will be used;
2. Make one copy of the Software solely for backup or archival purposes;
3. Make one hardcopy of any electronic documents included in the Software, provided that you receive the documents electronically.

RESTRICTIONS

You may NOT:

1. Use or copy the Software except as provided in this Agreement;
2. Rent or lease the Software to any third party;
3. Modify, adapt, or translate the Software in whole or in part;
4. Reverse engineer, decompile, or disassemble the Software or create derivative works based upon the Software;
5. Merge the Software with any other program or modify the Software, except for your personal use; and
6. Sublicense or otherwise make the Software available to third parties, except that you may, after prior written notification to Acer, transfer the Software as a whole to a third party so long as you do not retain any copies of the Software and such third party accepts the terms of this Agreement.
7. Transfer your rights under this Agreement to any third parties.
8. Export the Software in contravention of applicable export laws and regulations, or (i) sell, export, re-export, transfer, divert, disclose technical data, or dispose of, any Software to any prohibited person, entity, or destination including, without limitation, Cuba, Iran, North Korea,

Sudan and Syria; or (ii) use any Software for any use prohibited by the laws or regulations of the United States.

SUPPORT SERVICES

Acer is not obligated to provide technical or other support for the Software.

ACER LIVE UPDATE

Certain of the software contains elements that enable the use of the Acer Live Update service, which allows for updates for such software to be automatically downloaded and installed on your phone. By installing the software, you hereby agree and consent that Acer (or its licensors) may automatically check the version of such software that you are using on your phone and may provide upgrades to such software that may be automatically downloaded on to your phone.

OWNERSHIP AND COPYRIGHT

Title, ownership rights and intellectual property rights in and to the Software and all copies thereof shall remain with Acer or Acer's licensors or suppliers (as applicable). You do not have or shall not gain any proprietary interest in the Software (including any modifications or copies made by or for you) or any related intellectual property rights. Title and related rights in the content accessed through the Software is the property of the applicable content owner and may be protected by applicable law. This license gives you no rights to such contents. You hereby agree

1. Not to remove any copyright or other proprietary notices from the Software;
2. To reproduce all such notices on any authorized copies you make; and
3. To use best efforts to prevent any unauthorized copying of the Software.

TRADEMARKS

This Agreement does not grant to you any rights in connection with any trademarks or service marks of Acer or of Acer's licensors or suppliers.

DISCLAIMER OF WARRANTIES

TO THE MAXIMUM EXTENT PERMITTED BY APPLICABLE LAW, ACER, ITS SUPPLIERS, AND ITS LICENSORS, PROVIDE THE SOFTWARE "AS IS" AND WITH ALL FAULTS, AND HEREBY DISCLAIM ALL OTHER WARRANTIES AND CONDITIONS, EITHER EXPRESS, IMPLIED OR STATUTORY, INCLUDING, BUT NOT LIMITED TO, ANY IMPLIED WARRANTIES, DUTIES OR CONDITIONS OF MERCHANTABILITY, OF FITNESS FOR A PARTICULAR PURPOSE, OF ACCURACY OR COMPLETENESS OF RESPONSES, OF RESULTS, OF WORKMANLIKE EFFORT, OF LACK OF VIRUSES, AND OF LACK OF NEGLIGENCE, ALL WITH REGARD TO THE SOFTWARE AND THE PROVISION OF OR FAILURE TO PROVIDE SUPPORT SERVICES. ALSO, THERE IS NO WARRANTY OR CONDITION OF TITLE, QUIET ENJOYMENT, QUIET POSSESSION, CORRESPONDENCE TO DESCRIPTION OR NON-INFRINGEMENT WITH REGARD TO THE SOFTWARE.

EXCLUSION OF INCIDENTAL, CONSEQUENTIAL AND CERTAIN OTHER DAMAGES

TO THE MAXIMUM EXTENT PERMITTED BY APPLICABLE LAW, IN NO EVENT SHALL ACER, ACER'S SUPPLIERS, OR ACER'S LICENSORS, BE LIABLE FOR ANY SPECIAL, INCIDENTAL, INDIRECT, PUNITIVE, OR CONSEQUENTIAL DAMAGES WHATSOEVER (INCLUDING, BUT NOT LIMITED TO, DAMAGES FOR LOSS OF PROFITS OR CONFIDENTIAL OR OTHER INFORMATION, FOR BUSINESS INTERRUPTION, FOR PERSONAL INJURY, FOR LOSS OF PRIVACY, FOR FAILURE TO MEET ANY DUTY INCLUDING OF GOOD FAITH OR OF REASONABLE CARE, FOR NEGLIGENCE, AND FOR ANY OTHER PECUNIARY OR OTHER LOSS WHATSOEVER) ARISING OUT OF OR IN ANY WAY RELATED TO THE USE OF OR INABILITY TO USE THE SOFTWARE, THE PROVISION OF OR FAILURE TO PROVIDE SUPPORT SERVICES, OR OTHERWISE UNDER OR IN CONNECTION WITH ANY PROVISION OF THIS AGREEMENT, EVEN IN THE EVENT OF THE FAULT, TORT (INCLUDING

NEGLIGENCE), STRICT LIABILITY, BREACH OF CONTRACT OR BREACH OF WARRANTY OF ACER OR ITS SUPPLIERS OR LICENSORS, AND EVEN IF ACER AND ITS SUPPLIERS AND LICENSORS HAVE BEEN ADVISED OF THE POSSIBILITY OF SUCH DAMAGES.

LIMITATION OF LIABILITY AND REMEDIES

NOTWITHSTANDING ANY DAMAGES THAT YOU MIGHT INCUR FOR ANY REASON WHATSOEVER (INCLUDING, WITHOUT LIMITATION, ALL DAMAGES REFERENCED ABOVE AND ALL DIRECT OR GENERAL DAMAGES), THE ENTIRE LIABILITY OF ACER, ITS SUPPLIERS, AND ITS LICENSORS, UNDER ANY PROVISION OF THIS AGREEMENT, AND YOUR EXCLUSIVE REMEDY FOR ALL OF THE FOREGOING, SHALL BE LIMITED TO THE AGGREGATE AMOUNT PAID BY YOU FOR THE SOFTWARE. THE FOREGOING LIMITATIONS, EXCLUSIONS AND DISCLAIMERS (INCLUDING DISCLAIMER OF WARRANTIES AND EXCLUSION OF INCIDENTAL, CONSEQUENTIAL AND CERTAIN OTHER DAMAGES ABOVE) SHALL APPLY TO THE MAXIMUM EXTENT PERMITTED BY APPLICABLE LAW, EVEN IF ANY REMEDY FAILS ITS ESSENTIAL PURPOSE; PROVIDED, HOWEVER, THAT BECAUSE SOME JURISDICTIONS DO NOT ALLOW THE EXCLUSION OR LIMITATION OR LIABILITY FOR CONSEQUENTIAL OR INCIDENTAL DAMAGES, THE ABOVE LIMITATION MAY NOT APPLY TO YOU.

TERMINATION

Without prejudice to any other rights, Acer may immediately terminate this Agreement without notice if you fail to comply with any terms and conditions of this Agreement.

In such event, you must:

1. Cease all use of the Software;
2. Destroy or return to Acer the original and all copies of the Software; and
3. Delete the Software from all phones on which it was resident.

All disclaimers of warranties and limitation of liability set forth in this Agreement shall survive termination of this Agreement.

GENERAL

This Agreement represents the complete agreement between you and Acer relating to this license for the Software and supersedes all prior agreements, communications, proposals and representations between the parties and prevails over any conflicting or additional terms of any quote, order, acknowledgement or similar communication. This Agreement may only be modified by a written document signed by both parties. If any provision of this Agreement is held by a court of competent jurisdiction to be contrary to law that provision will be enforced to the maximum extent permissible and the remaining provisions of this Agreement will remain in full force and effect.

ADDITIONAL PROVISIONS APPLICABLE TO THIRD PARTY SOFTWARE AND SERVICES

Software provided hereunder by Acer's licensors or suppliers ("Third Party Software") is made available to you for your personal, non-commercial use only. You may not use the Third Party Software in any manner that could damage, disable, overburden, or impair the services provided by Acer's licensors or suppliers hereunder ("Third Party Services"). Furthermore, you may not use the Third Party Software in any manner that could interfere with any other party's use and enjoyment of the Third Party Services, or the services and products of Acer's licensors' or suppliers' third party licensors. Your use of the Third Party Software and Third Party Services is also subject to additional terms and conditions and policies which can be accessed through our global website.

Privacy policy

During registration you will be asked to submit some information to Acer. Please refer to Acer's privacy policy at www.acer.com or your local Acer website.