

Acer Liquid (S100)

User Guide

© 2009 All Rights Reserved

Acer Liquid (S100) Smartphone User Guide

First issue: 09/2009

Acer Liquid (S100) Smartphone

Model number: _____

Serial number: _____

Date of purchase: _____

Place of purchase: _____

Table of Contents

Getting to know your smartphone

Features and functions	5
Product registration	5

Chapter 1: Setting Up

Unpacking your smartphone	7
Getting to know your smartphone	8
Installing or removing the battery	10
Installing a SIM or microSD card	12
Turning on for the first time	13
Using the touchscreen	14
The home screen	15

Chapter 2: Making Calls

Before making a call	19
Making a call	19
The voice call screen	21
Onscreen call options	21

Chapter 3: Messaging

Creating a new message	23
Replying to a message	24
MMS messages	25
Setting up Email	27

Chapter 4: Using the Camera

Camera icons and indicators	29
Taking a photo	30
Shooting a video	31
Viewing photos and videos	31

Chapter 5: Advanced Settings

Putting your smartphone in airplane mode	33
------------------------------------------------	----

Acer Settings	34
Adjusting connection settings	35
Phone settings	37
Managing your contacts	38
Connecting to a PC	44
Multimedia playback	45
Resetting your smartphone	51
Chapter 6: Accessories and Tips	
Using the headset	53
Using a Bluetooth headset	53
Using your smartphone as a modem	54
Inserting a microSD card	56
Appendix	
FAQ and troubleshooting	57
Other sources of help	58
Specifications	58
Warnings and precautions	60
Emergency calls	66
Disposal and recycling information	67
Taking care of your smartphone	67
Safety regulations	68

Getting to know your smartphone

Features and functions

Your new smartphone offers leading, easy-to-access multimedia and entertainment features. You can:

- Access your email while on the move.
- Connect to the Internet at high speed, via HSDPA (7.2 Mbps), HSUPA (2 Mbps) or Wi-Fi.
- Keep in touch with your friends via your Contacts and social networking applications.

Product registration

When using your product for the first time, it is recommended that you immediately register it. This will give you access to some useful benefits, such as:

- Faster service from our trained representatives
- Membership in the Acer community: receive promotions and participate in customer surveys
- The latest news from Acer

Hurry and register, as other advantages await you!

How to register

To register your Acer product, visit our website at **registration.acer.com**. Choose your country and follow the simple instructions.

You can also register directly from your smartphone by tapping the Registration icon.

After we receive your product registration, you will be sent a confirmation email with important data that you should keep in a safe place.

Chapter 1: Setting Up

Unpacking your smartphone

Your new smartphone comes packed in a protective box. Carefully unpack the box and remove the contents. If any of the following items is missing or damaged, contact your dealer immediately:

- Acer Liquid (S100) Smartphone
- Battery
- Quick Guide
- Companion CD
- USB cable
- AC adapter
- Headset

Getting to know your smartphone

Views

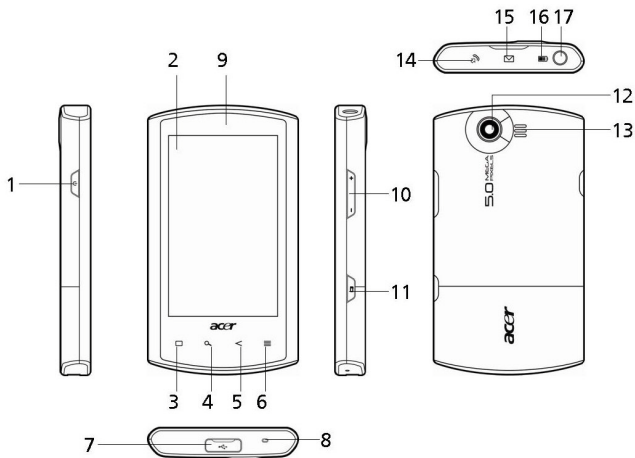

No.	Item	Description
1	Power button	Press to turn the screen on/off or enter sleep mode; press and hold to turn the smartphone off.
2	Touchscreen	3.5-inch, 800 x 480 pixel capacitive touchscreen to display data, phone content and enter information.
3	Home button	Return to the home screen.
4	Search button	Open the Google search function.
5	Back button	Go back one menu step.
6	Menu button	Opens the option menu.
7	Mini USB connector	Connect to a USB cable/charger.

No.	Item	Description
8	Microphone	Internal microphone.
9	Phone speaker	Emits audio from your smartphone; suitable for holding to your ear.
10	Volume up/down button	Increase or decrease the phone volume.
11	Camera button	Activate the camera or take a picture. Press down halfway to auto-focus.
12	Camera	A 5-megapixel camera for taking high-resolution images.
13	Handsfree speaker	Emits audio from your smartphone; suitable for handsfree use.
14	Call indicator	Indicates an incoming call or missed call.
15	Mail/message indicator	Indicates unread mail or other messages.
16	Charge indicator	Indicates battery charge status.
17	3.5 mm headphone jack	Connect to stereo headphones.

LED indicators

Call indicator:

LED state	Description
Off	No incoming or missed calls.
Fast flashing	Incoming call.
Slow flashing	Missed call(s).

Mail/message indicator:

LED state	Description
Off	No unread mail or messages.
Slow flashing	Unread mail or messages.

Charge indicator:

LED state	Description
Off	Normal status.
Constantly on	Battery is fully charged and the device is plugged in.
Slow flashing	Device plugged in: Battery is charging. Device unplugged: Battery is critically low and needs to be charged urgently.
Fast flashing	Battery is low and should be charged.

Installing or removing the battery

Your smartphone uses a replaceable battery to provide power. It is packed separately from your smartphone and needs to be inserted and charged before you can use the smartphone.

Installing the battery

Insert your fingernail into the cutout between the battery cover and the phone. Unclip the cover and lift off the battery cover.

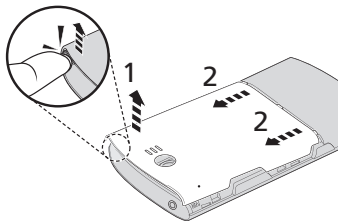

Place the battery into the battery compartment, lining up the battery connectors with those at the bottom of the compartment.

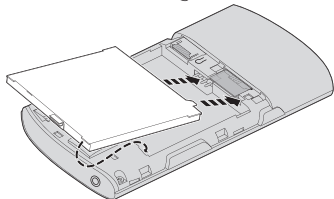

Insert the tabs on the bottom of the battery cover into the slots in the phone. Carefully press the top of the cover until the clips on the side of the cover click in place.

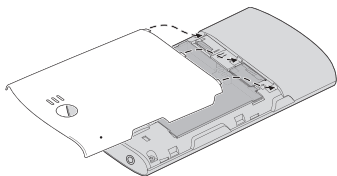

**CAUTION: RISK OF EXPLOSION IF BATTERY IS REPLACED BY AN INCORRECT TYPE.
DISPOSE OF USED BATTERIES ACCORDING TO THE INSTRUCTIONS.**

Charging the battery

For initial use, you need to charge your smartphone for eight hours. After that you can charge it each day to recharge the battery to full capacity.

Connect the AC adapter cord to the mini USB connector on your smartphone.

Removing the battery

Open the battery compartment as shown in **“Installing the battery”** on page 10. Lift the battery out of the compartment using the clip on the top of the battery.

Replace the battery cover as described above.

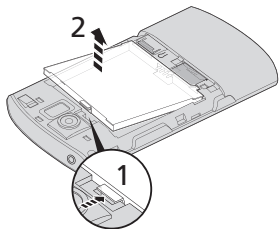

Installing a SIM or microSD card

To take full advantage of your smartphone's telephony capabilities, you must install a SIM card. The SIM card holder is located at the bottom of the battery bay.

Additionally, you may wish to increase your smartphone's storage by inserting a microSD card into the slot provided. This is next to the SIM card slot.

1. Turn off the phone by pressing and holding the power button.
2. Open the cover and remove the battery as described in **"Removing the battery" on page 11.**
3. Insert the SIM or microSD card as shown.
4. Replace the battery and battery cover.

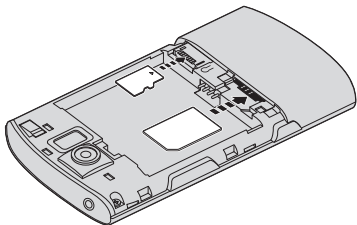

.....
NOTE: Ensure that the microSD card is inserted all the way into the card slot.
.....

SIM card lock

Your smartphone may come with a SIM card lock, i.e., you will only be able to use the SIM card provided by your network operator.

To cancel the SIM lock, contact your network provider.

Turning on for the first time

To turn on your smartphone for the first time, press and hold the power button until the system bootup screen appears.

Entering your PIN

When you install a SIM card for the first time, you may need to enter a PIN using the onscreen number pad.



.....
Important: Depending on your settings, you may be required to enter your PIN each time you switch on the phone function.
.....

If the PIN you enter is incorrect, a warning message appears.

Activating a new SIM card

If you are using your SIM card for the first time, it may require activation. Contact your network operator for details on how to do this.

Using the touchscreen

Your smartphone uses a touchscreen for selecting items and entering information. Use your finger to tap the screen.

Tap: Touch the screen once to open items and select options.

Drag: Hold your finger on the screen and drag across the screen to select text and images.

Tap and hold: Tap and hold an item to see a list of actions available for that item. On the pop-up menu that appears, tap the action you want to perform.

Scroll: To scroll up or down the screen, simply drag your finger up or down the screen in the direction that you want to scroll.

The onscreen keyboard

When you tap a text box to enter text, the onscreen keyboard will automatically display.



Text assistance

You can enable various features that assist you to enter correct text. Tap **Menu > Settings > Locale & Text > Android keyboard**. From here you can enable or disable the following:

Function	Description
Quick fixes	Corrects commonly typed mistakes.
Show suggestions	Shows suggested words while you are typing.
Auto-complete	Inserts the suggested word whenever you tap space or a punctuation mark.

The home screen

After rebooting, your smartphone will display the home screen. This screen gives you quick, icon-based access to many of the frequently-used features of your smartphone.

The first time you start your smartphone, you will see some icons on the screen.

At the bottom of the screen is the **Applications tab** which lists all the applications you have installed. Tap the tab to open the Applications tab. Tap an icon to open the application.



The extended home screen

The home screen extends to either side of the screen, giving you more room to add icons, widgets or features. To view the extended home screen slide your finger to the left or right of the home screen.

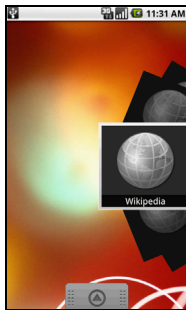
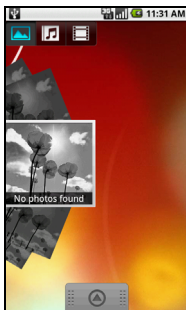

Personalizing the home screen

You may personalize your home screen by adding or removing icons, shortcuts or widgets, or changing the wallpaper.

Adding or removing icons

You can set icons for installed applications on the home screen. Tap and hold an icon in the Applications tab to copy it to the home screen. To remove an icon from the home screen, tap and drag the icon from the home screen to the trash tab that appears at the bottom of the screen.

Adding or removing shortcuts or widgets

To add shortcuts or widgets, tap and hold anywhere on the home screen to open the Add to home screen menu. Tap **Shortcuts** to open a list of available shortcut types you can add.

Widgets are handy applications that you can add to your home screen to display various information.

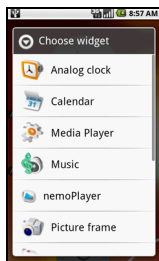
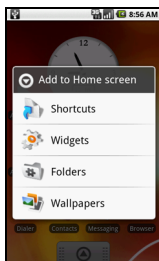



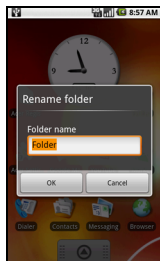





You can also add folders to your home screen. There are some pre-defined folders available or you can add a **New folder**. This will be placed on your home screen and named Folder. To change the name of the folder, tap it to open then tap and hold the name bar at the top of the folder window to open a dialog box that will allow you to rename the folder.



Notification area

At the top of the screen is the Notification area. This contains a variety of icons to inform you of your phone's status. To the left of the Notification area are event icons that indicate a new event. The icons on the right of the screen indicate connectivity status. Tap and hold the **Notification area** to view the new events.

Icon	Description
	Indicates that storage is running low. Remove programs or files to increase the available storage.
	SD Card removed.
	WLAN signal strength.
	Vibrate mode enabled.
	SIM card not installed/invalid.
	Battery status.
	Missed call.
	New/unread message.

Icon	Description
	3G connected: You may make a call.
	Connected to a 2G network: You may make a call.
	Airplane mode: Wireless connectivity disconnected. Please disable airplane mode before trying to make a call.
	Incoming call or active call.
	Charging has temporarily stopped to prevent overheating/overcharging.



Chapter 2: Making Calls

This chapter shows you how to make phone calls, and the various options available to you during your call.

Before making a call

Check that the phone function is on before you make a call. You can confirm the phone status from the icon on the right-hand side of the Notification area.

Icon	Description
------	-------------





3G connected: You may make a call.



Airplane mode: Wireless connectivity disconnected. Please disable airplane mode before trying to make a call.

Making a call

1. From the home screen tap **Dialer** or open **Dialer** from the menu to open the onscreen number pad.
2. Enter the number you wish to dial.
3. Tap  to make the call.
4. To end the call, tap .



Note: The phone function needs to be enabled before the call can be connected.

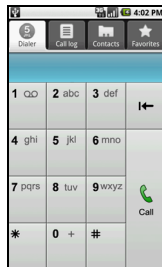

Dialing a number from Call Log

Your call history can be viewed by tapping the **Call Log** tab. It displays recent received, dialed, and missed calls.

Tap a number to view the call details. To redial any number in the call history, select the number and tap **Return call**. You may also select **Send SMS message** or **Add to contacts**.

Missed calls will be displayed by the call indicator on the top of your phone and in the Notification area with the icon .

You can also view missed calls from the Notification area.

1. Open the notification list by tapping and dragging the Notification area downwards to display the details of the missed calls.
2. Select the call from the list and tap **Return call** to return the missed call.

You can save phone numbers to your Contacts from the Call Log. Please refer to **"Adding a contact" on page 39** for further details.

Making a call to one of your contacts

1. Tap the **Contacts** tab in the dialer or **Contacts** from the home screen to view your contacts.
2. Tap a contact. A dialog will open, asking if you want to Call the contact or send the contact an SMS.

Dialing an international number

When dialing international numbers, there is no need to enter the international direct dialing prefix ('00' etc.) before the country code. Simply tap and hold **0+** on the onscreen number pad until **+** appears onscreen.



Warning: International call rates can vary greatly depending on the country you are calling and your network provider. We suggest you check all call rates with your network provider, to avoid excessive phone bills. If you are using your smartphone abroad, roaming charges will apply. Consult your network provider for roaming rates specific to the country you are visiting before you leave.

The voice call screen

Once you have dialed your number the voice call screen appears, which displays the number/contact you are talking to, the call duration and the dialpad tab.

Onscreen call options

Answering a call

Press **Answer** to answer a call.

Rejecting a call

Tap **Reject** to reject a call.

Ending a call

To end a call, press .

Using the speakerphone

The speakerphone function allows you to make calls without having to hold your smartphone. This handsfree function is especially useful for multitasking.

To activate the speakerphone, tap **Speaker**. Tap **Speaker** again to disable the speakerphone.

Muting a call

To mute a call, tap **Mute** on the voice call screen to switch off the microphone. Tap **Mute** again to switch the microphone back on.

Saving a dialed number to contacts

You can save a number you have dialed to your contacts for future use.

1. Select the number from the **Call log** tab, and tap **Add to contacts**.
2. Tap **Create new contact** and select how to complete the action. Please refer to **“Adding a contact” on page 39**.

Chapter 3: Messaging

This chapter shows you how to set up and use the SMS and MMS functions of your smartphone.

All SMS and MMS messages are accessed via Messaging. Messaging automatically arranges received and sent messages into threads.

To access Messaging tap **Messaging** on the home screen.

Creating a new message

You can use your phone to compose SMS or MMS messages.

Tap **New message** to compose a new message.





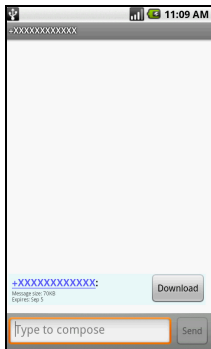



Enter the recipient's phone number or name in the **To** field. Suggested contacts will be displayed in a drop-down list below the text field. To select a suggested contact, tap the contact's name.

Once you have entered the recipient, enter your message in the text box labeled **Type to compose**.



Note: SMS messages may be up to 160 characters long. If your message is longer than 160 characters, it will be sent as multiple linked messages. Most phones will automatically join the linked messages to present the recipient with a single long message, however, some older phones do not have this ability.

Press the Menu button to see what options are available when creating a new message. The options change depending on the status of the message.







Icon	Description
	Convert the SMS to an MMS, allowing you to add a subject to the message.
	View all the threads currently on your phone.
	Convert the SMS to an MMS, allowing you to attach a file to the message.
	Open the Dialer to call the recipient.
	Discard the message.
	Insert a smiley/emoticon into your message text.
	Show other available options.
	Send the message.

Replying to a message

When a new text message arrives a message icon appears in the Notification area and the message icon on the top of the phone lights up.

Tap **Messaging** on the home screen to view the message list or expand the Notification area to see a summary of the message. Tap the summary to open the message list.

To reply to an SMS or MMS message, open the message from the message list. Enter your text in the text box labeled **Type to compose**. Press the Menu button to see available options.

Icon	Description
	Convert the SMS to an MMS, allowing you to add a subject to the message.
	Convert the SMS to an MMS, allowing you to attach a file to the message.
	Open the Dialer to call the recipient.
	Delete the thread.
	Insert a smiley/emoticon into your message text.
	Show other available options.
	Send the message.

MMS messages

MMS messages are similar to text messages but also allow you to attach multimedia files such as pictures, audio or video clips. Each MMS message can be up to 300 kB in size.



Note: You need to set up an MMS profile before you can send MMS messages. Normally, your smartphone will set up the profile for you based on information retrieved from your provider.



Tip: Ask your network provider for the necessary information if you need to manually set up the MMS profile.

Receiving MMS messages

When a new MMS message arrives, a message icon appears at the top of the screen and a notification message is displayed.

1. Open Messaging to view a summary of the message.
2. Tap **Download** to download the message content.



Note: Downloads can take a long time, depending on your connection quality. If you reply or open another application, the download will be stopped.



Important: You may be charged to download message content, especially if you are roaming. Please contact your provider if you have any questions.

3. Tap the message to view the content.
4. Press the Menu button and tap **Reply** to reply to the message. The message window will appear. Simple text replies will be sent as SMS messages. If you wish to attach a file, press the Menu button and tap **Attach**. You will be presented with a menu of options.
5. When you have finished composing the message, press the Menu button and tap **Send**.

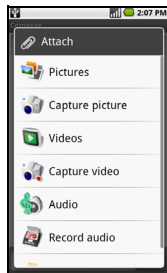

Setting up Email

Your smartphone enables you to access your email. Most popular ISPs can be set up in two steps. Tap the Applications tab and then **Email** to start setting up your email access.

If necessary, enter your email address and tap **Manual setup** to enter the parameters manually. Tap **Next** to finish the setup process.

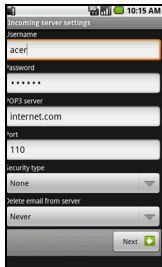

Chapter 4: Using the Camera

Your smartphone features a 5-megapixel digital camera mounted on the rear. This section will take you through all the steps in taking photos and videos with your smartphone.



.....
Note: You need to have a microSD card inserted into the microSD slot before you can use the camera.
.....





To activate the camera, press the camera button or tap the Applications tab > **Camera**.

Camera icons and indicators



In the camera window, the three icons on the left show you the current settings. Use the zoom slider at the bottom of the screen to adjust the zoom.

To adjust the settings, press the Menu button. The menu options are:

Icon	Description
 Switch to camcorder	Switch to camcorder mode to shoot video.
 Resolution	Set the photo resolution.
 White balance	Adjust the white balance.
 Effects	Apply an effect to the photo/video. Effects are: <ul style="list-style-type: none">• Mono: Black and white.• Negative: Uses negative colors.• Solarize: Highlights green and blue hues.• Sepia: Gives a brown/sepia tint.• Posterize: Highlights the red hues.• Aqua: Gives an aqua tint.
 Settings	Change the default settings. Settings are: <ul style="list-style-type: none">• Store GPS data in pictures:• JPEG quality: Set the JPG quality.• Anti banding: Set anti banding.• Focus settings: Set auto or infinity focus.• Resolution: Set the photo resolution.• Effects: Apply an effect to the photo.• White balance/lighting: Adjust the white balance.• Contrast: Adjust the contrast.• Brightness: Set the brightness.• ISO: Set the ISO.• Self timer: Adjust the self timer.

Taking a photo

1. Ensure you have adjusted the parameters described above.
2. Frame your subject and steady your smartphone.
3. Zoom in or out as needed.
4. Press the camera button down halfway to focus. The focus frame will turn green. Push the button down the rest of the way to take the photo.

Shooting a video

Turn on camcorder mode by tapping the video icon from the camera menu.

1. Ensure you have adjusted the parameters described above.
2. Frame your subject and steady your smartphone.
3. Zoom in or out as needed.
4. Press the camera button down halfway to focus. The focus frame will turn green.
5. Press the camera button down fully to begin recording.
6. Press the camera button down fully to stop recording.

Supported formats

The following file formats are supported:

Type	Formats
Image	JPEG
Video	3GP, MPEG-4, H.263

Viewing photos and videos

After you have taken your photo or video, it is automatically saved.

Once you have taken a photo or video, you can view the it in

Gallery by tapping . Alternatively, open the Applications tab and tap **Gallery**. From Gallery you can share the file directly via **Acer Share** (to **Flickr** or **Facebook**), **Gmail**, **Messaging**, **Picasa**, **YouTube** or as a **Roadsync** message.



.....
Note: Share options vary depending on the file type.
.....

Chapter 5: Advanced Settings

Putting your smartphone in airplane mode

You can enter airplane mode (also known as flight mode) to turn off telephone, Bluetooth and wireless LAN functions and use your smartphone as a handheld device during a flight. Check with your airline to make sure this is permitted onboard.

Switch your smartphone off during takeoff and landing as it may interfere with aircraft electronic systems.

Turning airplane mode on or off

1. Press and hold the power button until you get the phone options menu.
2. Tap **Airplane mode** to switch it ON or OFF.



Note: When Airplane mode is active, the  icon will be displayed in the Notification area.

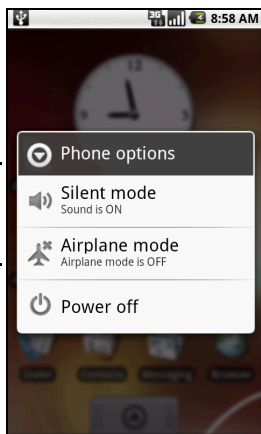

Activating or deactivating connections

Open the Applications tab and tap **Settings** > **Wireless controls** to manage your connection settings. You can choose to activate one or all connections from the Acer Settings.

Each connection icon will be highlighted when turned on.

Acer Settings

Acer Settings is a convenient all-in-one place for you to adjust commonly-used settings on your phone. Open the Applications tab and tap **Acer Settings**, or tap **Acer Settings** on the home screen.

From this screen you can turn Wi-Fi and Bluetooth on or off or adjust their settings by tapping .

You can also set your **Phone network settings**, set the screen **Brightness** or **Screen Timeout**.



Important: If your phone is in Airplane mode, the option to turn Wi-Fi and Bluetooth on will be disabled. Please refer to **“Putting your smartphone in airplane mode” on page 33** for instructions on turning Airplane mode on or off.

Phone network settings

Tap **Phone network settings** to adjust your network settings. You can turn data connection on or off when roaming. Restrict the connection to 2G networks only, specify a network operator and define access point names. Please refer to **“Selecting a network” on page 36**.

Adjusting connection settings

This section will show you how to adjust detailed settings for your phone, data, Wi-Fi and Bluetooth connections.

Item	Description
Wi-Fi	Turn the Wi-Fi function on or off.
Wi-Fi settings	Set up and manage your wireless access points.
Bluetooth	Turn the Bluetooth function on or off.
Bluetooth settings	Manage your Bluetooth connections, set a device name and discoverability.
VPN settings	Set up and manage Virtual Private Networks.
Mobile networks	Set your options for connecting to mobile networks.
Airplane mode	Disable all wireless connections so you can safely use this device onboard an aircraft.

Phone connections

Once you have inserted a SIM card, your smartphone will automatically detect your network provider.

You can adjust your phone settings by tapping **Settings** > **Sound & display**.

Item	Description
Silent mode	Turn off all sounds except for alarms and media.
Ringer volume	Adjust the ringer volume.
Media volume	Set the playback volume for media.
Phone ringtone	Set your phone's ringtone.
Phone vibrate	Turn on the vibrate function.
Notification ringtone	Set a ringtone for notifications.

Item	Description
Audible touch tones	Play a sound whenever a screen selection is made.
SD card notifications	Play a sound for SD card notifications.
Orientation	Switch screen orientation when the smartphone is rotated.
Animation	Animate when opening or closing windows.
Brightness	Adjust screen brightness.
Enable Light Sensor	Turn the light sensor on or off.
Screen timeout	Set a delay before the screen will be turned off.

Selecting a network

Your phone will automatically detect your carrier/network settings when you insert a new SIM card. However, you may prefer to manually select a network. This may be a good idea when roaming.



.....
Tip: When you are traveling, manually selecting a network may help to reduce your roaming charges. Check with your home service provider for the network offering the most competitive rates at your destination.
.....

Selecting a network

1. Open the Applications tab and tap **Settings > Wireless controls > Mobile networks > Network operators**.
2. Your phone will search for available networks.
3. Select your preferred network from the list generated. Your phone will attempt to register on the selected network.

4. Tap **Select automatically** to connect to the available network with the strongest signal. This may lead to your phone jumping between networks when you move around.



.....
Note: Contact your service provider should you have any problems obtaining voice mail and the text message service center numbers.
.....

Adjusting Bluetooth settings

You can use Bluetooth to exchange information between your smartphone and other mobile devices.

Bluetooth connections

For all Bluetooth settings, open the Applications tab and tap **Settings > Wireless controls > Bluetooth settings**. Here you can switch Bluetooth on or off, set a device name and discoverability. Tap **Scan for devices** to scan for available devices.

To connect to a device, tap the device in the list of available devices. You may be asked to enter a PIN on both devices to establish the connection.

Phone settings

Many phone settings are automatically configured by your smartphone when you insert a SIM card. The device will communicate with your service provider and automatically obtain all necessary settings, such as network name, voice mail and text message center numbers.

You can also view and modify these settings manually through the Phone Settings screen.

Open the Applications tab and tap **Settings > Wireless controls > Call settings**.





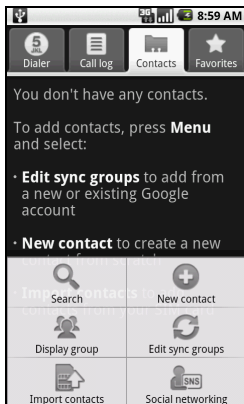

Managing your contacts

Your smartphone features an address book that allows you to save contacts to either the internal memory or onto your SIM card.

Tap **Contacts** from the home screen or the **Contacts** tab from the Dialer to view your contacts.

If you don't have any contacts stored on your phone, you can import your Google account contacts, add a new contact or import any SIM contacts. Press the Menu button to open the menu.



Icon	Description
	Search for a contact.
	Add a new contact.
	Display the contacts you have assigned to a group.
	Sign in to your Gmail/Google mail account and sync selected groups of contacts.
	Import contacts stored on your SIM card to your phone.
	Set up your Social Networking Service. Once you have set up your SNS, you will be able to view and update your Flickr or Facebook content from your smartphone.

Adding a contact

Tap **New contact** to add a new contact. You will be asked if you want to **Create contact** or **Create RoadSync contact**.



Note: RoadSync is an application that allows you to access your Outlook-based email and contacts. For more information on this application, please refer to: www.dataviz.com/products/roadsync/android/

To create a contact, you will be asked to enter the contact's:

- First and Last name.
- Phone numbers.
- Email addresses.
- Social Network Service information.
- Chat addresses.
- Postal addresses.

You may also:

- Enter information such as organizations the contact belongs to.
- Any personal notes about the contact.
- Set a ringtone.
- Send any calls from this contact directly to your voice-mail.

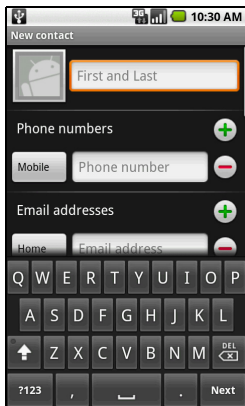

Social Networking

You can add social networking information for each contact. This allows you to quickly and easily view your contact's social networking updates.

When you tap **Social Networking**, you will be presented with a list of supported sites.

Tap a site to be redirected to a page that will allow you to search for the contact's personal pages. Once you have found the contact's personal home page on the site, tap **Add** to store the URL.

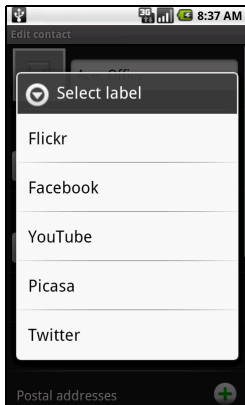

Note: For Facebook you will need to log in to your own Facebook account. This uses a Facebook application and requires your permission before proceeding.

To view any updates your contacts may have made to their social networking sites, you will need to open **Contacts** from the applications tab or home screen. Press the Menu button then tap **Social networking**. Press the Menu button again then tap **Sync Now**. Tap the Back button to return to the contacts list. You will see icons indicating which contacts have updated content.



Note: Each time you connect to Facebook, you may be asked if you'd like to sync your Facebook contacts and phone contacts. The application will only sync if there is a full-name match.

Setting up your own social networking

You can also share your photos and videos via your own social networking sites. Open **Contacts**, press the menu button and tap **Social Networking**. This will open a menu with Flickr and Facebook. Select the site you would like to use.

For **Flickr**, you will need to sign in. Then **Create an upload-to-Flickr email address** on the page you see (unless you already have an upload email address defined). Follow the onscreen instructions to obtain the address. Copy the email address into the text box labeled **Upload email**. This will allow **Acer Share** to upload your content directly to Flickr.

For **Facebook** you will need to authorize your phone on your Facebook account. Once authorized, you will be able to update your Facebook profile from your smartphone.

urFooz

urFooz is your portable profile that lives where you live.

- **Fooz Creator** lets you create a Fooz avatar, which is your virtual look-a-like.
- **Fooz World** lets you edit and manage your Fooz avatar(s), create new avatars and share them on Facebook, MySpace, blogs and more.
- **Share it** lets you post your Fooz card to Facebook, MySpace and other social networks. You can also email it to your friends.

You can email your Fooz card to friends, or post it to your social networks and blogs and always be connected.

Launching urFooz

To launch urFooz, tap **UrFooz** from the applications tab.

Creating your urFooz avatar

If you have not yet set up an account to urFooz, tap the **Get Started** button. If you have an existing urFooz account, select Sign in and login with your email and password.

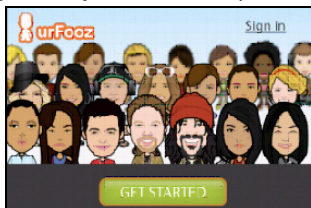

To start creating your avatar, select your Gender, Ethnicity, Zodiac Sign, Relationship Status and Areas of Interest.

Next, start customizing your avatar. Tap **Features** to choose your face shape, eyes, nose, mouth and other facial features. Select **Clothing** to dress your avatar. Select **Accessories** to choose other items such as earrings, headbands, and whatever else to give your Fooz avatar your personal touch. Simply tap the image to apply the item to your avatar and preview how it looks on the left side of the screen.

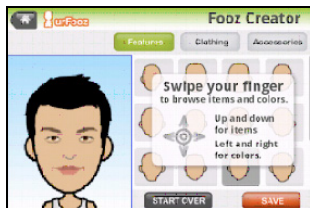

Select **SAVE** and type in a name for your Fooz avatar. The next screen will ask you for the email address, password, and required user information. The email and password you enter will be used to sign into your urFooz account.

Managing your avatar

Now that you have created your Fooz avatar, go to Fooz World and personalize your Fooz card, or your portable profile.

Select **Profile/Apps** to fill in your profile and other information such as bookmarks of your social network profiles and favorite websites.

Select **Switch Avatar** to change your default avatar, modify existing avatars, or create a new avatar.



Sharing your Fooz card and avatar

urFooz lets you share your Fooz card with friends by posting it to your social networks, blogs, and websites; or emailing it to friends.

In Fooz World, select Share it. Select Post to post your Fooz card to Facebook or other social networks, or select Email to email your Fooz card to a friend.





.....
Note: Fuhu, Spinlets, Spinlet, urFooz, Fooz Avatars, Fooz Creator, Fooz Card, and Fooz World are trademarks or registered trademarks of Fuhu, Inc. in the U.S. and/or other countries.
.....

Managing contacts

You may edit a contact, copy the contact to your SIM card or delete a contact.

1. Open **Contacts** from the home screen or from the Dialer.
2. Select and open a contact.
3. Press the Menu button to **Edit contact**, **Copy to SIM** or **Delete contact**.

Copying a contact from the SIM card to internal memory

1. Open **Contacts** from the home screen or Dialer.
2. Press the Menu button and tap **Import contacts**.
3. Select the contact you want to copy.
4. Select how you wish to create the contact.

Connecting to a PC

You can connect your phone to a PC using the supplied USB cable. Ensure you have installed the drivers included on the companion CD before connecting your phone to a PC.

Plug the mini USB sync cable into the mini USB connector on your smartphone. Plug the USB client connector into an available USB port on your computer.

Synchronizing your calendar

You can sync your calendar on your phone with your Google calendar. Tap **Calendar** from the Applications tab to connect to your Google calendar and sync appointments.

Browsing the Internet

In order to browse the Internet with your smartphone, you must be connected to a 3G network.

Tap **Browser** on the home screen to start browsing. To open a new website, press the Menu button then tap **Open** to enter a URL.

Multimedia playback

Your smartphone comes supplied with a variety of programs that you can use to enjoy multimedia content.

nemoPlayer

Open **nemoPlayer** from the applications tab to play media you have stored on your phone.

nemoPlayer enables you to listen to music, view video clips and pictures in the following formats.

Type	Formats
Audio playback	MP3, AAC, AMR
Ringtone	MP3, MIDI, iMelody, WAVE
Video recording	3GP, MPEG-4, H.263
Video playback	3GP, MPEG-4, H.263, H.264

Spinlets

Spinlets gives you access to your favorite music, movie and television content. Get your favorite music, photos and videos from your mobile phone and share your favorite Spinlets on social networks, websites and more.



.....
Note: Some contents may not be available in some countries.
.....

Launching Spinlets

To launch the Spinlets application, tap **Spinlets** in the applications tab.

Browsing Spinlets gallery

You can sort or search your media content by albums or genres.

Browsing albums

Once Spinlets is opened, you will see a display of featured albums. Browse this display by sliding your finger horizontally (left or right), and select an album by tapping it.

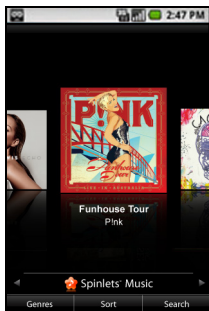

Browsing genres

To browse the Gallery by genre, tap the **Genres** button on the bottom left corner of the screen. You will see a new screen with a list of different genres. Tap on the genre you wish to view.

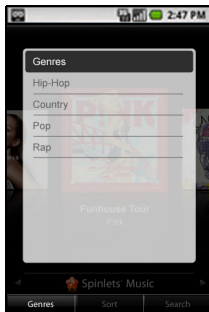

Sort

To sort through Spinlets by Name, Ratings, or Newest content, select the Sort button at the bottom of the screen.

Search

To search the Gallery for a specific name, select the Search button at the bottom right corner of the screen. Type the name of an artist in the search box and find potential matches.

Exploring Spinlets widgets

When you select an album, you will see a Spinlet.

To play the featured song, select the red **Play** button.

To play selected songs, select the Music tab and choose which songs you would like to play.

To view artist photos, select the Photos tab.

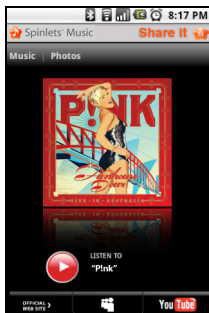

To visit the artist's social networks and websites, select the icons located along the bottom of the screen.

Sharing your Spinlets

You can share your favorite Spinlets in two ways.

To post the Spinlet you are currently viewing to your social networks, blogs, or other websites, tap **Share It** at the top right corner of the Spinlet. Select Post it and tap the icon of the social network site or blog you want to post the widget to. Log in to your social network account or blog page and follow the steps.

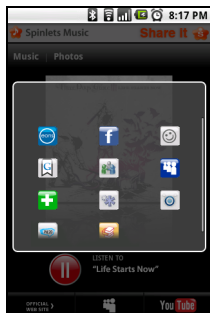

Another way you can share Spinlets is through email. Tap **Share It** at the top right corner of the Spinlet, select Send it, and enter your name and your friend's email address.



.....
Note: Fuhu, Spinlets, Spinlet, urFooz, Fooz Avatars, Fooz Creator, Fooz Card, and Fooz World are trademarks or registered trademarks of Fuhu, Inc. in the U.S. and/or other countries.
.....

Digital media server

Your phone can act as a Digital media server. This means that you can use it to send media content to other home entertainment devices.

To set up the Digital media server, open the Applications tab and tap **Digital media server**.

You will need to enable **Share Contents** before you can start using the service.

You may select to share your **Video**, **Photo** or **Playlist** content from **Share Content Settings**.

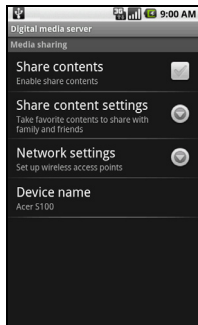

Tip: For more information on DLNA, please refer to www.dlna.org/home

Adjusting the volume

Adjust the volume of your phone using the volume button on the side of the phone. Alternatively, you can set the **Ringer volume** and **Media volume** by opening the Applications tab and going to **Settings > Sound & display**.

Setting the date and time

Set the date and time by opening the Applications tab and going to **Settings > Date & time**.



Tip: If you travel frequently or live in an area that uses daylight saving time, activate **Automatic** from this menu. This will enable

your smartphone to set the date and time based on information it receives from the network.

Setting alarms

There are three predefined alarms on your phone by default. To edit alarm settings, tap **Alarm clock** in the Applications tab. You may:

- Turn the alarm on or off.
- Set the alarm time.
- Set a ringtone.
- Enable or disable vibrate.
- Set which days to repeat the alarm.
- Give it a label.

Changing location and text options

Set your location and language input preferences by opening the Applications tab and going to **Settings > Locale & text**.

Managing applications



Warning! Make sure you trust the source of any program you install. If you are not sure of the source, do not install a program. Installing programs from unknown sources increases your risk of virus attacks and theft of personal and private data.

You can remove programs installed on your smartphone to free up extra storage memory. Open the Applications tab and going to **Settings > Applications**.

Here you can allow programs from **Unknown sources** to be installed and **Manage applications**.



.....
Warning! You should only remove programs if you are familiar with the Android operating system.
.....

Obtaining and installing applications

Your smartphone uses the open-source Android platform. To obtain and install applications for your smartphone, you can tap **Market** on the home screen to open the Google marketplace.



.....
Note: This requires a Gmail/Google mail account.
.....

Turning on Hearing Aid Compatibility mode

To turn on HAC, open the **Applications** tab, tap **Settings > Call settings > Advanced settings > HAC**.

Resetting your smartphone

You may have to perform a reset if your smartphone fails to respond when buttons are pressed or the screen is tapped.



.....
Note: Before performing a reset, ensure that your smartphone is not locked. Press any key or tap the screen to see if the phone responds.
.....

Clean boot



.....
Warning! You should only perform a clean boot when all other options have failed to restore your smartphone to an operational state.
.....

A clean boot will restore your smartphone to the factory settings.



.....
Warning! This will erase all your personal information, any contacts stored on your phone and any programs you installed.
.....

Press and hold the Power until you feel your smartphone vibrate and/or you see the Acer logo screen. Press and hold the Volume up and Volume down buttons.

Chapter 6: Accessories and Tips

This chapter shows you how to use accessories with your smartphone, as well as provide useful tips for when you are using your smartphone.

Using the headset

Your smartphone comes packaged with a headset with built-in microphone for handsfree use when making calls.

To use the headset, plug it into the 3.5 mm headphone jack at the top of the phone.

When the headset is plugged in, all audio is routed to the headset, and the speakers are turned off.

- To answer an incoming call, press the button on the microphone.
- Adjust the volume using the volume up/down button on the smartphone.
- End the call by pressing the button again.

Using a Bluetooth headset

Your smartphone's Bluetooth functions make it fully compatible with all Bluetooth headsets. This allows you to use the unit handsfree when making calls, without the inconvenience of wires.

Using your smartphone as a modem



Note: When using your smartphone as a modem, the data connection on the device will be disabled.

When connected to your PC, your smartphone can function as a modem via GPRS, HSDPA or UMTS.

When you insert your SIM card, your phone automatically configure itself to use your provider's GPRS/3G/EDGE service.



Important: You may need to configure modem settings, such as initial command and baud rate, before using your smartphone as a modem. For details, please contact your service provider.

Setting up the modem on your PC

Connect your smartphone to a PC using the supplied USB cable. Ensure you have installed the drivers from the companion CD. Once the driver has been installed, you will see a device named Acer USB modem in the Windows Device Manager.

If you are using Windows XP:

1. Open Windows Network Connections and create a new connection.
2. In the New Connection Wizard, choose **Set up my connection manually**.
3. Choose **Connect using dial-up modem**. Select **Acer USB modem** and click **Next**.
4. Give the connection a name and enter the dial-up number, your username and password. If you don't have a username

or password, leave the fields blank. Click **Next** to finish the setup process.

If you are using Windows Vista or Windows 7:

1. Open Windows Network and Sharing Center.
2. Choose **Set up a new connection or network**.
3. Select **Set up a dial-up connection**.
4. Enter the dial-up number, your username and password.
Click **Connect** to finish the setup process.

To connect, click the dial-up connection.



Note: If you do not have the dial-up number or username and password, please contact your network.

Creating a new access point

When you need to add another GPRS/3G/EDGE connection on your phone, obtain the access point name and settings (including username and password if required) from your wireless service provider.

1. Open the Applications tab and tap **Settings > Wireless controls > Mobile networks > Access Point Names**.
2. Press the Menu button and tap **New APN**.
3. Enter the APN settings. Tap an item to adjust it.
4. When you have finished press the Menu button and tap **Save**.



Important: Some providers and countries do not allow the use of a smartphone as a modem over HSDPA. Please check with your provider before attempting to do so.

Inserting a microSD card

Your smartphone features a memory expansion slot that accepts a microSD card to expand memory and storage capacity.

Please refer to **"Installing a SIM or microSD card"** on page 12 for proper instructions on installing a microSD card.

Appendix

FAQ and troubleshooting

This section lists frequently asked questions that may arise during the use of your smartphone, and gives easy answers and solutions to these questions.

Aspect	Question	Answer
Audio	Why is there no sound coming from the device?	If the headset is plugged into the device, the speaker is automatically shut off. Disconnect the headset. Check that the device volume setting is not muted. Check that the volume control is not at its lowest setting.
Multimedia files	Why can't I view my picture files?	You may be trying to view an image that is not supported. Refer to "Multimedia" on page 59 for more information.
	Why can't I view my video files?	You may be trying to view a video that is not supported. Refer to "Multimedia" on page 59 for more information.
	Why can't I play my music files?	You may be trying to play a file that is not supported. Refer to "Multimedia" on page 59 for more information.
System information and performance	How do I check the OS version of my device?	Tap Menu > Settings > About phone to check the OS version (Kernel/build number) and other hardware and software information.

Aspect	Question	Answer
Power	I couldn't turn on the device.	The battery power may be depleted. Recharge the device. Refer to "Installing a SIM or microSD card" on page 12 for more information.

Other sources of help

For information on:

Programs on your smartphone and additional programs that can be installed on your smartphone	This User Guide. Included on the smartphone companion CD, it provides online reference for using your smartphone.
Up-to-date information regarding your smartphone	www.acer.com/
Service enquiries	www.acer.com/support/

Specifications

Performance

- Qualcomm QSD 8250, 768 MHz
- System memory:
 - 256 MB of SDRAM
 - 512 MB of Flash ROM
- Google Android operating system

Display

- 3.5" TFT-LCD capacitive touchscreen
- 800 x 480 resolution
- 65K colors support

Multimedia

- CD-quality stereo output
- Mono speaker 0.5 W (max)
- Omni-directional microphone
- Formats supported

Type	Formats
Audio playback	MP3, AAC, AMR
Ringtone	MP3, MIDI, DLS, iMelody, WAVE
Video recording	3GP, MPEG-4, H.263
Video playback	3GP, MPEG-4, H.263, H.264

USB connector

- 10-pin mini USB connector
- USB Client
- DC power-in (5 V, 1 A)

Connectivity

- Bluetooth 2.0+EDR
- IEEE Wi-Fi 802.11 b/g WLAN
- GSM 850 / 1800 / 1900
- UMTS 850 / 1900 / 2100
- HSDPA / HSUPA / EDGE / GPRS

Camera

- 5-megapixel
- Auto-focus

Expansion

- microSD memory card (up to 32 GB)

Battery

- High density, rechargeable 1350 mAh Lithium Polymer battery (replaceable)



.....
Note: Length of battery operation will depend on power consumption which is based on system resource use. For example, constantly using the backlight or using power-demanding applications will shorten battery life between charges.
.....

Dimensions

- Stylish, light and robust design

Height	115 mm
Width	64 mm
Thickness	12.75 mm (13.5 mm at camera area)
Weight	<135 g (with battery)

Warnings and precautions

- Do not use this product near water.
- Do not place this product on an unstable cart, stand or table. If the product falls, it could be seriously damaged.
- Slots and openings are provided for ventilation to ensure reliable operation of the product and to protect it from overheating. These openings must not be blocked or covered. The openings should never be blocked by placing the product on a bed, sofa, rug or other similar surface. This product should never be placed near or over a radiator or heat register, or in a built-in installation unless proper ventilation is provided.

- Never push objects of any kind into this product through cabinet slots as they may touch dangerous voltage points or short-out parts that could result in a fire or electric shock. Never spill liquid of any kind onto or into the product.
- To avoid damage of internal components and to prevent battery leakage, do not place the product on a vibrating surface.
- Never use this product when engaging in sporting activities, exercising, or in any vibrating environment which may cause a short circuit or damage, and even a risk of explosion from the battery pack.

CAUTION when listening to music

To protect your hearing, follow these instructions.

- Increase the volume gradually until you can hear clearly and comfortably.
- Do not increase the volume level after your ears have adjusted.
- Do not listen to music at high volumes for extended periods.
- Do not increase the volume to block out noisy surroundings.
- Decrease the volume if you can't hear people speaking near you.

Battery information

This product uses a Lithium Polymer battery. Do not use it in a humid, wet and/or corrosive environment. Do not put, store or leave your product in or near a heat source, in a high temperature location, in strong direct sunlight, in a microwave oven or in a pressurized container, and do not expose it to temperatures over 60 °C (140 °F). Failure to follow these

guidelines may cause the battery to leak acid, become hot, explode or ignite and cause injury and/or damage. Do not pierce, open or disassemble the battery. If the battery leaks and you come into contact with the leaked fluids, rinse thoroughly with water and seek medical attention immediately. For safety reasons, and to prolong the lifetime of the battery, charging will not occur at low (below 0 °C/32 °F) or high (over 40 °C/104 °F) temperatures.

The full performance of a new battery is achieved only after two or three complete charge and discharge cycles. The battery can be charged and discharged hundreds of times, but it will eventually wear out. When the talk and standby times are noticeably shorter than normal, buy a new battery. Use only Acer approved batteries, and recharge your battery only with Acer approved chargers designated for this device.

Unplug the charger from the electrical plug and the device when not in use. Do not leave a fully charged battery connected to the ac charger, since overcharging may shorten its lifetime. If left unused, a fully charged battery will lose its charge over time. If the battery is completely discharged, it may take a few minutes before the charging indicator appears on the display or before any calls can be made.

Use the battery only for its intended purpose. Never use any charger or battery that is damaged.

Do not short-circuit the battery. Accidental short-circuiting can occur when a metallic object such as a coin, clip, or pen causes direct connection of the positive (+) and negative (-) terminals of the battery. (These look like metal strips on the battery.) This might happen, for example, when you carry a spare battery in your pocket or purse. Short-circuiting the terminals may damage the battery or the connecting object.

Leaving the battery in hot or cold places, such as in a closed car in summer or winter conditions, will reduce the capacity and lifetime of the battery. Always try to keep the battery between

15 °C and 25 °C (59 °F and 77 °F). A device with a hot or cold battery may not work temporarily, even when the battery is fully charged. Battery performance is particularly limited in temperatures well below freezing.

Do not dispose of batteries in a fire as they may explode. Batteries may also explode if damaged. Dispose of batteries according to local regulations. Please recycle when possible. Do not dispose as household waste.

Replacing the battery pack

Your smartphone uses lithium batteries. Replace the battery with the same type as that which came bundled with your product. Use of another battery may present a risk of fire or explosion.



.....
Warning! Batteries may explode if not handled properly. Do not disassemble or dispose of them in fire. Keep them away from children. Follow local regulations when disposing of used batteries.
.....

Additional safety information

Your device and its enhancements may contain small parts. Keep them out of the reach of small children.

Operating environment



.....
Warning! For safety reasons, turn off all wireless or radio transmitting devices when using your smartphone device under the following conditions. These devices may include, but are not limited to: wireless LAN (WLAN), Bluetooth and/or 3G.
.....

Remember to follow any special regulations in force in any area, and always switch off your device when its use is prohibited or when it may cause interference or danger. Use the device only in its normal operating positions. This device

meets RF exposure guidelines when used normally, and it and its antenna are positioned at least 2.5 cm (1") away from your body. Do not cover the antenna with metal and you should position the device at the above-stated distance from your body. To successfully transmit data files or messages, this device requires a good quality connection to the network. In some cases, transmission of data files or messages may be delayed until such a connection is available. Ensure that the above separation distance instructions are followed until the transmission is completed. Parts of the device are magnetic. Metallic materials may be attracted to the device, and persons with hearing aids should not hold the device to the ear with the hearing aid. Do not place credit cards or other magnetic storage media near the device, because information stored on them may be erased.

Medical devices

Operation of any radio transmitting equipment, including wireless phones, may interfere with the functionality of inadequately protected medical devices. Consult a physician or the manufacturer of the medical device to determine if they are adequately shielded from external RF energy or if you have any questions. Switch off your device in health care facilities when any regulations posted in these areas instruct you to do so. Hospitals or health care facilities may be using equipment that could be sensitive to external RF transmissions.

Pacemakers. Pacemaker manufacturers recommend that a minimum separation of 15.3 cm (6") be maintained between wireless devices and a pacemaker to avoid potential interference with the pacemaker. These recommendations are consistent with the independent research by and recommendations of Wireless Technology Research. Persons with pacemakers should do the following:

- Always keep the device more than 15.3 cm (6") from the pacemaker.
- Not carry the device near your pacemaker when the device is switched on. If you suspect interference, switch off your device, and move it.

Vehicles

RF signals may affect improperly installed or inadequately shielded electronic systems in motor vehicles such as electronic fuel injection systems, electronic antiskid (antilock) braking systems, electronic speed control systems, and air bag systems. For more information, check with the manufacturer, or its representative, of your vehicle or any equipment that has been added. Only qualified personnel should service the device, or install the device in a vehicle. Faulty installation or service may be dangerous and may invalidate any warranty that may apply to the device. Check regularly that all wireless equipment in your vehicle is mounted and operating properly. Do not store or carry flammable liquids, gases, or explosive materials in the same compartment as the device, its parts, or enhancements. For vehicles equipped with an air bag, remember that air bags inflate with great force. Do not place objects, including installed or portable wireless equipment in the area over the air bag or in the air bag deployment area. If in-vehicle wireless equipment is improperly installed, and the air bag inflates, serious injury could result. Using your device while flying in aircraft is prohibited. Switch off your device before boarding an aircraft. The use of wireless teledevices in an aircraft may be dangerous to the operation of the aircraft, disrupt the wireless telephone network, and may be illegal.

Potentially explosive environments

Switch off your device when in any area with a potentially explosive atmosphere and obey all signs and instructions.

Potentially explosive atmospheres include areas where you would normally be advised to turn off your vehicle engine. Sparks in such areas could cause an explosion or fire resulting in bodily injury or even death. Switch off the device at refueling points such as near gas pumps at service stations. Observe restrictions on the use of radio equipment in fuel depots, storage, and distribution areas; chemical plants; or where blasting operations are in progress. Areas with a potentially explosive atmospheres are often, but not always, clearly marked. They include below deck on boats, chemical transfer or storage facilities, vehicles using liquefied petroleum gas (such as propane or butane), and areas where the air contains chemicals or particles such as grain, dust or metal powders.

Follow any restrictions. Do not use the device where blasting is in progress.

Emergency calls

Important: Wireless phones, including this device, operate using radio signals, wireless networks, landline networks, and user-programmed functions. Because of this, connections in all conditions cannot be guaranteed. You should never rely solely on any wireless device for essential communications like medical emergencies.

If certain features are in use, you may first need to turn those features off before you can make an emergency call. Consult this guide or your service provider for more information.

When making an emergency call, give all the necessary information as accurately as possible. Your wireless device may be the only means of communication at the scene of an accident. Do not end the call until given permission to do so.

Disposal and recycling information

Do not throw this electronic device into the trash when discarding.

To minimize pollution and ensure utmost protection of the global environment, please recycle. For more information on the Waste from Electrical and Electronics Equipment (WEEE) regulations, visit

www.acer-group.com/public/Sustainability/sustainability01.htm



Mercury advisory

For projectors or electronic products containing an LCD/CRT monitor or display:

Lamp(s) inside this product contain mercury and must be recycled or disposed of according to local, state or federal laws. For more information, contact the Electronic Industries Alliance at www.eiae.org. For lamp-specific disposal information, check www.lamprecycle.org.



Taking care of your smartphone

1. **DO** take care not to scratch the screen of your smartphone. Keep the screen clean. When working with your smartphone, use your finger or fingernail. Never use an actual pen or pencil or other sharp object on the screen surface.

2. **DO NOT** expose your smartphone to rain or moisture. Do not let water enter the circuitry through the front panel buttons or expansion slots. In general, treat your smartphone as you would a mobile phone or other small electronic device.
3. **DO** be careful not to drop your smartphone or subject it to any strong impact. Do not place your smartphone in your back pocket.
4. **DO NOT** expose your smartphone to extreme temperatures. For example, do not leave your smartphone on the dashboard of a car on a hot day or when temperatures are below freezing point. Also, keep it away from heaters and other sources of heat.
5. **DO NOT** use or store your smartphone in any location that is dusty, damp or wet.
6. **DO** use a soft, damp cloth to clean your smartphone. If the surface of the screen becomes soiled, clean it with a soft cloth moistened with diluted window-cleaning solution.
7. **DO NOT** press down on the screen with force, otherwise you may crack the screen.

Safety regulations

LCD pixel statement

The LCD unit is produced with high-precision manufacturing techniques. Nevertheless, some pixels may occasionally misfire or appear as black or red dots. This has no effect on the recorded image and does not constitute a malfunction.

Radio device regulatory notice



.....
Note: Regulatory information below is for models with wireless LAN and/or Bluetooth only.
.....

General

This product complies with the radio frequency and safety standards of any country or region in which it has been approved for wireless use. Depending on configuration, this product may or may not contain wireless radio devices (such as wireless LAN and/or Bluetooth modules). Information below is for products with such devices.

Wireless operation channels for different domains

N. America	2.412-2.462 GHz	Ch01 through Ch11
Japan	2.412-2.484 GHz	Ch01 through Ch14
Europe ETSI	2.412-2.472 GHz	Ch01 through Ch13

France: Restricted wireless frequency bands

Some areas of France have a restricted frequency band. The worst case maximum authorized power indoors is:

- 10 mW for the entire 2.4 GHz band (2400 MHz - 2483.5 MHz)
- 100 mW for frequencies between 2446.5 MHz and 2483.5 MHz



.....
Note: Channels 10 through 13 inclusive operate in the band 2446.6 MHz to 2483.5 MHz.
.....

There are few possibilities for outdoor use: On private property or on the private property of public persons, use is subject to a preliminary authorization procedure by the Ministry of Defense, with maximum authorized power of 100

mW in the 2446.5 - 2483.5 MHz band. Use outdoors on public property is not permitted.

In the departments listed below, for the entire 2.4 GHz band:

- Maximum authorized power indoors is 100 mW
- Maximum authorized power outdoors is 10 mW

Departments in which the use of the 2400 - 2483.5 MHz band is permitted with an EIRP of less than 100 mW indoors and less than 10 mW outdoors:

01 Ain Orientales	02 Aisne	03 Allier
05 Hautes Alpes	08 Ardennes	09 Ariège
11 Aude	12 Aveyron	16 Charente
24 Dordogne	25 Doubs	26 Drome
32 Gers	36 Indre	37 Indre et Loire
41 Loir et Cher	45 Loret	50 Manche
55 Meuse	58 Nièvre	59 Nord
60 Oise	61 Orne	63 Puy Du Dome
64 Pyrenees Atlantique	66 Pyrenees	67 Bas Rhin
68 Haut Rhin	70 Haute Saone	71 Saone et Loire
75 Paris	82 Tarn et Garonne	84 Vaucluse
88 Vosges	89 Yonne	90 Territoire de Belfort
94 Val de Marne		

This requirement is likely to change over time, allowing you to use your wireless LAN card in more areas within France. Please

check with ART for the latest information (www.art-telecom.fr).



.....
Note: Your WLAN Card transmits less than 100 mW, but more than 10 mW.
.....

FCC regulations:

This mobile phone complies with part 15 of the FCC Rules. Operation is subject to the following two conditions: (1) This device may not cause harmful interference, and (2) this device must accept any interference received, including interference that may cause undesired operation.

This mobile phone has been tested and found to comply with the limits for a Class B digital device, pursuant to Part 15 of the FCC Rules. These limits are designed to provide reasonable protection against harmful interference in a residential installation. This equipment generates, uses and can radiated radio frequency energy and, if not installed and used in accordance with the instructions, may cause harmful interference to radio communications. However, there is no guarantee that interference will not occur in a particular installation. If this equipment does cause harmful interference to radio or television reception, which can be determined by turning the equipment off and on, the user is encouraged to try to correct the interference by one or more of the following measures:

- Reorient or relocate the receiving antenna.
- Increase the separation between the equipment and receiver.
- Connect the equipment into an outlet on a circuit different from that to which the receiver is connected.
- Consult the dealer or an experienced radio/TV technician for help.

Changes or modifications not expressly approved by the party responsible for compliance could void the user's authority to operate the equipment.

The antenna(s) used for this transmitter must not be co-located or operating in conjunction with any other antenna or transmitter.

RF exposure information (SAR)

This mobile phone meets the government's requirements for exposure to radio waves.

This phone is designed and manufactured not to exceed the emission limits for exposure to radio frequency (RF) energy set by the Federal Communications Commission of the U.S. Government.

The exposure standard for wireless mobile phones employs a unit of measurement known as the Specific Absorption Rate, or SAR. The SAR limit set by the FCC is 1.6W/kg.

Tests for SAR are conducted using standard operating positions accepted by the FCC with the phone transmitting at its highest certified power level in all tested frequency bands. Although the SAR is determined at the highest certified power level, the actual SAR level of the phone while operating can be well below the maximum value. This is because the phone is designed to operate at multiple power levels so as to use only the power required to reach the network. In general, the closer you are to a wireless base station antenna, the lower the power output.

The highest SAR value for the model phone as reported to the FCC when tested for use at the ear is 1.21 W/kg and when worn on the body, as described in this user guide, is 0.732 W/kg.



Important: Body-worn measurements differ among phone models, depending upon available enhancements and FCC requirements.

While there may be differences between the SAR levels of various phones and at various positions, they all meet the government requirements.

The FCC has granted an Equipment Authorization for this model phone with all reported SAR levels evaluated as in compliance with the FCC RF exposure guidelines. SAR information on this model phone is on file with the FCC and can be found under the Display Grant section of **www.fcc.gov/oet/fccid** after searching on **FCC ID: HLZSHS100**.

For body worn operation, this phone has been tested and meets the FCC RF exposure guidelines for use with an accessory that contains no metal and the positions the handset a minimum of 2.5 cm from the body. Use of other enhancements may not ensure compliance with FCC RF exposure guidelines. If you do not use a body-worn accessory and are not holding the phone at the ear, position the handset a minimum of 2.5 cm from your body when the phone is switched on.

Using your phone with a hearing aid device

Your S100 device is compliant with the FCC Hearing Aid Compatibility (HAC) requirements. When some wireless phones are used near some hearing devices (hearing aids and cochlear implants) users may detect a buzzing, humming, or whining noise. Some hearing devices are more immune than others to this interference noise, and phones also vary in the amount of interference they generate. The wireless telephone industry has developed ratings for some of their mobile phones, to assist hearing-device users in finding phones that

may be compatible with their hearing devices. Not all phones have been rated. Phones that have been rated have a label on the box. Your S100 has been tested for hearing aid device compatibility and has an M3 and/or T3 rating.

These ratings are not guarantees. Results will vary, depending on the level of immunity of your hearing device and the degree of your hearing loss. If your hearing device happens to be vulnerable to interference, you may not be able to use a rated phone successfully. Trying out the phone with your hearing device is the best way to evaluate it for your personal needs.

M-Ratings: Phones rated M3 or M4 meet FCC requirements and are likely to generate less interference with hearing devices than phones that are not labeled. M4 is the better/higher of the two ratings.

T-Ratings: Phones rated T3 or T4 meet FCC requirements and are likely to be more usable with a hearing device's telecoil ("T Switch" or "Telephone Switch") than unrated phones. T4 is the better/higher of the two ratings.



.....
Note: Not all hearing devices contain telecoils.
.....

The more immune your hearing aid device is, the less likely you are to experience interference noise from your wireless phone. Hearing aid devices should have ratings similar to those of phones. Ask your hearing health-care professional for the rating of your hearing aid.

Hearing devices may also be measured for immunity to this type of interference. Your hearing device manufacturer or hearing health professional may help you find results for your hearing device. The more immune your hearing aid is, the less likely you are to experience interference noise from wireless devices.

For additional information about the FCC's actions with regard to hearing aid compatible wireless devices and other steps the FCC has taken to ensure that individuals with disabilities have access to telecommunications services, please go to www.fcc.gov/cgb/dro

Lithium-ion battery warning



ATTENZIONE! Rischio di esplosione della batteria se sostituita in modo errato. Sostituire la batteria con un una di tipo uguale o equivalente consigliata dalla fabbrica. Non disperdere le batterie nell'ambiente.



VORSICHT! Explosionsgefahr bei unsachgemäßen Austausch der Batterie. Ersatz nur durch denselben oder einem vom Hersteller empfohlenem ähnlichen Typ. Entsorgung gebrauchter Batterien nach Angaben des Herstellers.



ADVARSELI! Lithiumbatteri - Eksplosionsfare ved fejlagtig håndtering. Udskiftning må kun ske med batteri af samme fabrikat og type. Levér det brugte batteri tilbage til leverandøren.



WARNING! Explosionsfara vid felaktigt batteribyte. Använd samma batterityp eller en ekvivalent typ som rekommenderas av apparattillverkaren. Kassera använt batteri enligt fabrikantens instruktion.



VAROITUS! Paristo voi räjähtää, jos se on virheellisesti asennettu. Vaihda paristo ainoastaan laitevalmistajan suosittellemaan tyyppiin. Hävitä käytetty paristo valmistajan ohjeiden mukaisesti.



ATTENTION ! Il y a danger d'explosion s'il y a remplacement incorrect de la batterie. Remplacer uniquement avec une batterie du même type ou d' un type équivalent recommandé par le constructeur. Mettre au rebut les batteries usagées conformément aux instructions du fabricant.



ADVARSEL! Eksplosjonsfare ved feilaktig skifte av batteri. Benytt samme batteritype eller en tilsvarende type anbefalt av apparatfabrikanten. Brukte batterier kasseres i henhold til fabrikantens instruksjoner.

	B			I
battery			international numbers	20
charging	11		L	
information	60		LED indicators	9
Bluetooth			M	
connections	37		MMS messages	25
headset	53		O	
	C		onscreen keyboard	14
call history	20		P	
calls			performance	58
answering	21		phone	
ending	21		connections	35, 36
onscreen options	21		settings	37
camera			S	
icons and indicators	29		safety regulations	60
information	59		speakerphone	21
shooting a video	31		specifications	58
supported formats	31		spinlets	46
taking a photo	30		T	
connectivity	59		troubleshooting	57
contacts			turning on	13
adding and editing	39		U	
making calls to a contact	20		urFooz	41
	D		USB connector	59
display	58		V	
	E		views	
email	27		left	9
	F		voice calls	
FAQs	57		the voice call screen	21
	G		volume	
GPRS	54		adjusting	49
	H			
Hearing Aid Compatibility	51			
help				
sources	58			

