



Table of Contents

<i>Preface</i>	2
<i>Chapter 1 Installation</i>	4
Unpacking	4
Connecting the LCD Monitor and Base	4
Viewing Angle Adjustment	4
Detaching LCD Monitor from Its Stand.....	5
Interface for Arm Applications	5
Connecting the Display to your Computer	5
Connecting the AC Power	7
Setting Up the LCD Monitor	7
Power Management System.....	7
<i>Chapter 2 Display Controls</i>	8
User Controls	8
Adjusting the Monitor's Display.....	8
Function Description.....	10
<i>Chapter 3 Technical Information</i>	12
Specifications.....	12
Standard Timing Table	15
Troubleshooting.....	17

LCD MONITOR

Preface

This manual is designed to assist users in setting up and using the LCD Monitor. Information in this document has been carefully checked for accuracy; however, no guarantee is given to the correctness of the contents. The information in this document is subject to change without notice. This document contains proprietary information protected by copyright. All rights are reserved. No part of this manual may be reproduced by any mechanical, electronic or other means, in any form, without prior written permission of the manufacturer.

FCC Statement Warning

This equipment has been tested and found to comply with the limits for a Class B digital device, pursuant to Part 15 of the FCC Rules. These limits are designed to provide reasonable protection against harmful interference in a residential installation. This equipment generates, uses, and can radiate radio frequency energy, and if not installed and used in accordance with the instruction, may cause harmful interference to radio communications. However, there is no guarantee that interference will not occur in a particular installation. If this equipment does cause harmful interference to radio or television reception, which can be determined by turning the equipment off and on, the user is encouraged to try to correct the interference by one or more of the following measures:

- Reorient or relocate the receiving antenna.
- Increase the separation between the equipment and the receiver.
- Connect the equipment into an outlet on a circuit different from that to which the receiver is connected.
- Consult the dealer or an experienced radio/TV technician for help.

Any changes or modifications not expressly approved by the manufacturers may void the user's authority to operate this equipment.

NOTE

A shielded-type signal cord is required in order to meet the FCC emission limits and also to prevent interference to the radio and television reception. It is essential that only the supplied signal cord be used.

Canadian DOC Notice



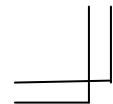

This Class B digital apparatus meets all requirements of the Canadian Interference-Causing Equipment Regulations.

Cet appareil numérique de la classe B respecte toutes les exigences du Règlement sur le matériel brouilleur du Canada.

ENGLISH

Important Safety Instructions

Please read the following instructions carefully. This manual should be retained for future use.

1. To clean LCD Monitor screen;
 - Power off LCD Monitor and unplug the AC Cord.
 - Spray a non-solvent cleaning solution onto a rag.
 - Gently clean the screen with dampened rag.
2. Do not place the LCD Monitor near a window. Exposing the monitor to rain water, moisture or sunlight can severely damage it.
3. Do not apply pressure to the LCD screen. Excess pressure may cause permanent damage to the display.
4. Do not remove the cover or attempt to service this unit by yourself. Servicing of any nature should be performed by an authorized technician.
5. Store LCD Monitor in a room with a room temperature of $-20^{\circ} \sim 60^{\circ}\text{C}$ (or $-4^{\circ} \sim 140^{\circ}\text{F}$). Storing the LCD Monitor outside this range could result in permanent damage.
6. If any of the following occurs, immediately unplug your monitor and call an authorized technician.
 - * Monitor to PC signal cable is frayed or damaged.
 - * Liquid spilled into LCD Monitor or the monitor has been exposed to rain.
 - * LCD Monitor or the case is damaged.
7. A certified line is required to connect this device to a power outlet. For a nominal current up to 6A and a device weight above 3 kg, a line not lighter than H05VV-F, 3G, 0.75 mm^2 must be used.
8. For use only with power supply type: Li-shin, LSE 9802A1240

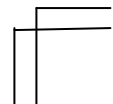
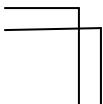

Chapter 1 Installation

Unpacking

Before unpacking the LCD Monitor, prepare a suitable workspace for your Monitor and computer. You need a stable and clean surface near a wall power outlet. Make sure that LCD Monitor has enough space around it for sufficient airflow. Though the LCD Monitor uses very little power, some ventilation is needed to ensure that the Monitor does not become too hot.

After you unpack the LCD Monitor, make sure that the following items were included in the box:

- * LCD Monitor
- * 1.5M Monitor-to-PC signal Cable
- * User's Manual
- * AC Adapter
- * 1.8M Power Cord
- * Base

If you find that any of these items is missing or appears damaged, contact your dealer immediately.

Connecting the LCD Monitor and Base

When you open the box to take the base and put on the desk first. Then connect the LCD Monitor and base please. (See fig.1-1)

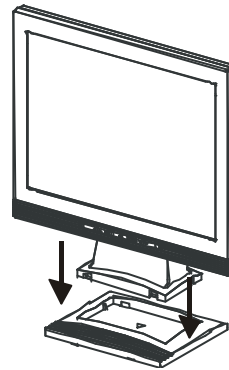

Figure 1-1

Viewing Angle Adjustment

The LCD Monitor is designed to allow users to have a comfortable viewing angle. The viewing angle can be adjusted from -5° to $+35^{\circ}$. (See fig. 1-2)

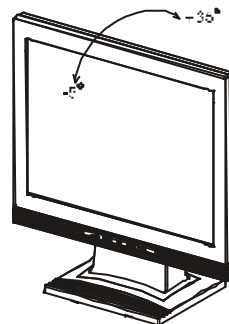

Figure 1-2

Warning

Do not force the LCD Monitor over its maximum viewing angle settings as stated above. Attempting this will result in damaging the Monitor and Monitor stand.

Detaching LCD Monitor from Its Stand

1. Unscrew screws of the hinge bracket ❶
2. Remove the stand from LCD monitor ❷
(See fig. 1-3)

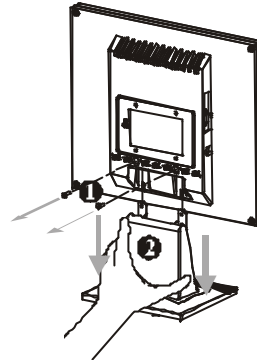

Figure 1-3

Interface for Arm Applications

Before installing to mounting device, please refer to Fig.1-3.

The rear of this LCD display has four integrated 4 mm, 0.7 pitches threaded nuts, as well as four 5 mm access holes in the plastic covering as illustrated in Figure 1-4. These specifications meet the **VESA Flat Panel Monitor Physical Mounting Interface Standard** (paragraphs 2.1 and 2.1.3, version 1, dated 13 November 1997).

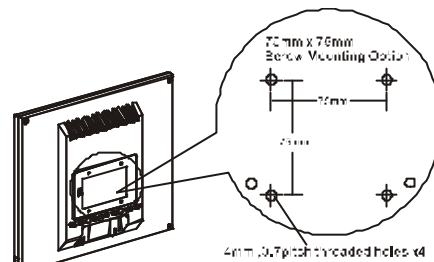

Figure 1-4

Connecting the Display to your Computer

1. Power off your computer.
2. Connect one end of the signal cable to the LCD Monitor's VGA port. (See Fig. 1-5)
3. Connect the other end of the signal cable to the VGA port on your PC.
4. Make sure both connections are secure.

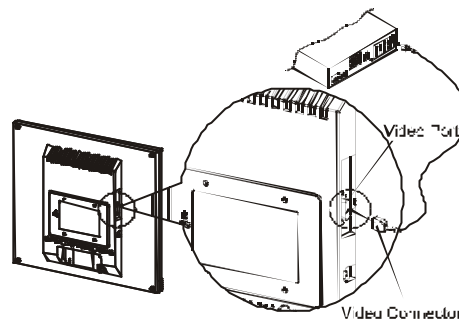
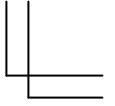
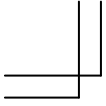

Figure 1-5

Attention

This device must be connected to an off-the-shelf video cable in order to comply with FCC regulations. A ferrite-core interface cable is included in the LCD Monitor package. This device will not be in compliance with FCC regulations when a non-ferrite-core video cable is



used.

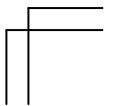
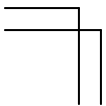

Connecting the AC Power

1. Connect the power cord to the AC adapter.
(See Fig. 1-6)
2. Connect the AC adapter's DC output connector to the DC Power Jack of the monitor.
3. Connect the power cord to an AC power source.

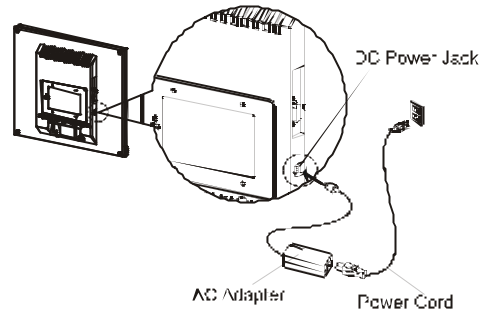

Figure 1-6

Warning

We recommend to install a "Surge Protector" device between the AC Adapter and the electrical wall outlet for adding protection against power surges to prevent the effects of sudden voltage variations from reaching the LCD Monitor. Sudden power surges may damage your monitor.

Setting Up the LCD Monitor

1. Make sure the AC Adapter is connected to the LCD Monitor.
2. Turn on the LCD Monitor's power switch, located on the bezel of the monitor.

Power Management System

This LCD Monitor complies with the VESA DPMS (version 1.0) Power Management guidelines. The VESA DPMS provides four power saving modes through detecting a horizontal or vertical sync. signal.

When the LCD Monitor is in power saving mode, the monitor screen will be blank and the power LED indicator will light yellow.

Chapter 2 Display Controls

User Controls

A brief description and the location of all LCD Monitor function controls and indicators:

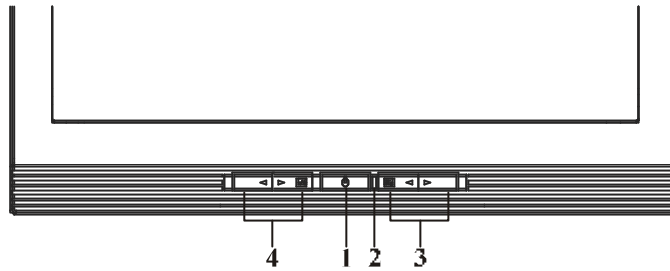

Figure 2-1

1	DC Power Switch	Press the power switch to switch the monitor ON/OFF.
2	DC Power-On Indicator	LED lights Green color --- Power is ON. LED lights Yellow --- Monitor is in "Power Saving Mode". LED is off --- Power is OFF.
3	Function Select Buttons	Press either left or right control button for OSD (On Screen Display) menu selection.
4	Adjustment Control Buttons	Press the left button to decrease the OSD setting and press the right button to increase the OSD setting.

Adjusting the Monitor's Display

The monitor has four function control buttons to select among functions shown on OSD menu, designed for easy user-viewing environments.

OSD Function Menu

To access OSD Main menu, simply press one of the Function Select control buttons, and the menu diagram will pop up on the screen as shown on Fig. 2-2:

Continue pressing the Function Select buttons to scroll through the entire menu items, then press Adjustment Control buttons to adjust content of selected item.

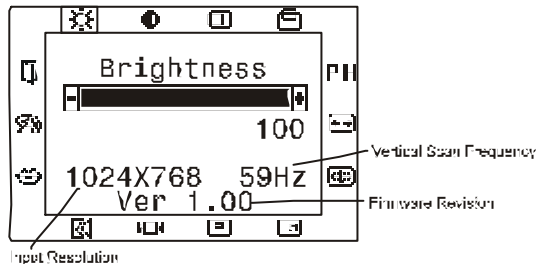
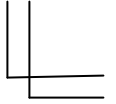
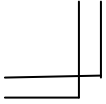

Figure 2-2

Attention

Firmware revision may have been updated into a latest version while the version number shown on



all OSD menus in this manual will stay as Ver. 1.00.

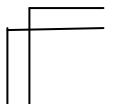
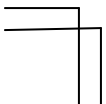

Function Description

Icon	Function	Function Description
	Brightness	This function increases or decreases the brightness of the image.
	Contrast	This function increases or decreases the difference between the dark and light color.
	H-Position	This function shifts the entire display image left or right.
	V-Position	This function shifts the entire display image up or down.
PH	Phase	A total of 32 scales (0 to 31) are available to adjust the focus and clarity of the display.
	Clock	This function carries a frequency tracking feature that offers the user to have better stability and clarity. Increasing Clock value can be up to +50 scales. The number of decreasing Clock (minus) is depend on the input timing.
	Auto Adjustment	This function will adjust the display size automatically to fit full screen.
	OSD H-Position	This function moves the OSD menu window left or right.
	OSD V-Position	This function moves the OSD menu window up or down.
	Graph Text	This function is to choose a display that allows maximum graphics text quality. The resolution selection can either be 640 x 400 or 720 x 400. Please refer to Chapter 3 “ Standard Timing” Table for of different timing modes.
	Recall	The recall function will return all adjusted parameters to factory preset values.
	Language	Five OSD language options are available: English, German, French, Spanish and Italian. Press the left or right Adjustment Control button to select other language.
	Color management	Hue: 100 scales of hue are available to adjust hue from green to red. Saturation: 100 scales of saturation are available to choose from 0 to 100. Color Temp.: Push the (+ -) button to select a different color temperature. Please see the diagram below for function and description.
	Save Exit	Saves the values of this setting and exits the OSD menu function.

Icon	Function	Description
9300	CIE coordinated Color Temperature of 9300° K	Sets the CIE coordinate color temperature to 9300° K
6500	CIE coordinated Color Temperature of 6500° K	Sets the CIE coordinate color temperature to 6500° K

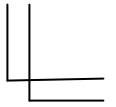
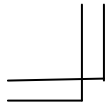

User	Three colors (Red, Green, Blue) can be adjusted from the OSD menu	Sets the settings to a by user defined CIE Temperature.
-------------	---	---

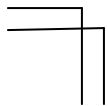

Chapter 3 Technical Information

Specifications

LCD Panel	Hannstar	AU
Size	15.0" (38 cm)	15.0" (38 cm)
Display Type	Active matrix color TFT LCD	Active matrix color TFT LCD
Resolution	1024 x 768	1024 x 768
Display Dot	1024 x (RGB) x 768	1024 x (RGB) x 768
Display Area (mm)	304 x 228 (H x V)	304 x 228 (H x V)
Display Color	262K	262K
Brightness	200 cd/m ² (typical)	200 cd/m ² (typical)
Contrast Ratio	300: 1 (typical)	350: 1 (typical)
Response Time	(15 + 35) ms (typical)	30 ms (Tr+Tf) (typical)
Lamp Voltage	640 Vrms (typical)	630 Vrms (typical)
Lamp Current	6.0 mA rms. (typical)	6.5 mA rms. (typical)
Viewing Angle	Vertical: -45° ~ +40° Horizontal: -60° ~ +60°	Vertical: -60° ~ +40° Horizontal: -60° ~ +60°

Display Colors 16.7M with FRC or Dithering

Video

Input Signal	Analog RGB 0.7Vp-p
Input Impedance	75 Ohm ± 2%
Polarity	Positive
Amplitude	0 - 0.7 ± 0.05 Vp
Multi-mode Supported	Horizontal Frequency: 24 ~ 61 KHz Vertical Frequency: 56 ~ 75 Hz

Control

Power	On/Off switch with LED indicator
-------	----------------------------------

OSD

Brightness	Digital
Contrast	Digital
Horizontal Position	Digital
Vertical Position	Digital
Phase	Digital
Clock	Digital
Display Mode Setup	Use EEPROM to save settings in memory

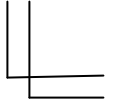
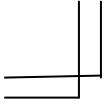

OSD Format

20 characters x 9 rows

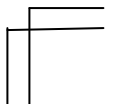
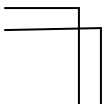

Power Management

Mode	Power Consumption*	AC Input	LED Color
On	25W maximum	240 VAC	Green
Standby	5W maximum	240 VAC	Yellow
Suspend	5W maximum	240 VAC	Yellow
Off	5W maximum	240 VAC	Yellow
DC Power Off	5W maximum	240 VAC	Dark
Disconnected	5W maximum	240 VAC	Yellow: Standby, Suspend, Off Dark: DC Power off

* Meeting VESA DPMS requirements measured from AC Input end of AC adapter.

Sync Input

Signal Separate TTL compatible horizontal and vertical synchronization
Polarity Positive and negative

Plug & Play

Supports VESA DDC1 and DDC2B functions

External Connection

Power Input (DC input) +12 VDC / 2.5A min. input through AC/DC adapter
Video Cable 1.5M with 15-pin D-sub connector

Environment**Operating Condition:**

Temperature 5°C to 40°C/41°F to 104°F
Relative Humidity 20% to 80%

Storage Condition:

Temperature -20°C to 60° C/-4°F to 140° F
Relative Humidity 5% to 85%

Power Supply (AC Adapter)

Input Voltage Single phase, 100 ~ 240VAC, 50 / 60 Hz
Input Current 1.5 A maximum

Size and Weight

Dimensions 349.6 (W) x 371.5 (H) x 158 (D) mm

Net Weight 3.2 ± 0.3 kg
 Gross Weight 4.7 ± 0.3 kg

Pin Assignment

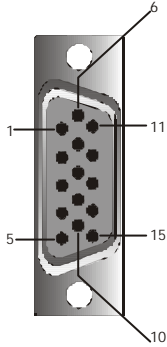
	Signal		Signal	
	PIN	Description	PIN	Description
	1	Red	9	+5V
2	Green	10	NC	
3	Blue	11	Digital GND	
4	Digital GND	12	SDA	
5	Digital GND	13	H. Sync.	
6	Red Rtn	14	V. Sync.	
7	Green Rtn	15	SCL	
8	Blue Rtn			

Standard Timing Table

If the selected timing is NOT included in table below, this LCD monitor will use the most suitable available timing.

Resolution	H. Freq. (KHz)	V. Freq. (Hz)	Pixel Freq. (MHz)	H/V Sync. Polarity	Mode
640 x 350	31.469	70.087	25.175	+/-	VGA-350
640 x 400	24.830	56.420	21.050	-/-	NEC PC9801
640 x 400	31.469	70.087	25.175	-/+, -/-	VGA-400-GRAPH NEC PC9821
640 x 480	31.469	59.940	25.175	-/-	VGA-480
640 x 480	37.861	72.809	31.500	-/-	VESA - 480 - 72Hz
640 x 480	37.500	75.000	31.500	-/-	VESA - 480 - 75Hz
720 x 400	31.469	70.087	28.322	-/+	VESA-400-TEXT
800 x 600	35.156	56.250	36.000	+/+	SVGA
800 x 600	37.879	60.317	40.000	+/+	VESA-600-60 Hz
800 x 600	48.077	72.188	50.000	+/+	VESA-600-72 Hz
800 x 600	46.875	75.000	49.500	+/+	VESA-600-75 Hz
832 x 624	49.725	74.55	57.2832	-/-	APPLE MAC-800
1024x 768	48.363	60.004	65.000	-/-	XGA

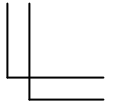
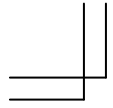

ENGLISH

1024x 768	53.964	66.132	71.664	+/+	COMPAQ-XGA
1024x 768	56.476	70.069	75.000	-/-	VESA-768-70 Hz
1024x 768	60.023	75.029	78.750	+/+	VESA-768-75 Hz

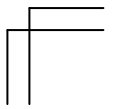
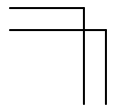

Troubleshooting

This LCD Monitor has pre-adjusted using factory standard VGA timings. Due to the output timing differences among various VGA cards in the market, users may initially experience an unstable or unclear display whenever a new display mode or new VGA card is selected.

Attention

This LCD Monitor Supports Multiple VGA Modes.

Refer to the Standard Timing Table for a listing of modes supported by this LCD Monitor.

PROBLEM Picture is unclear and unstable

The picture is unclear and unstable, please perform the following steps :

1. Enter PC to “Shut Down Windows” status while you’re in MS-Windows environment.
2. Check the screen to see if there’s any black vertical stripes appear. If there are, take advantage of the “Clock” function in OSD menu and adjust (by increment or decrement numbers) until those bars disappear.
3. Move to “Phase” function in OSD menu again and adjust the monitor screen to its most clear display.
4. Click “No” on “Shut Down Windows” and back to the normal PC operating environment.

PROBLEM There is no picture on LCD Monitor

If there’s no picture on the LCD Monitor, please perform the following steps:

1. Make sure the power indicator on the LCD Monitor is ON, all connections are secured, and the system is running on the correct timing. Refer to Chapter 3 for information on timing.
2. Turn off the LCD Monitor and then turn it back on again. If there is still no picture, press the Adjustment Control button several times.
3. If step 2 doesn’t work, connect your PC system to another external CRT. If your PC system Functions properly with a CRT Monitor but it does not function with the LCD Monitor, the output timing of the VGA card may be out of the LCD’s synchronous range. Please change to an alternative mode listed in the Standard Timing Table or replace the VGA card, and then repeat steps 1 and 2.

PROBLEM There is no picture on LCD Monitor

If you have chosen an output timing that is outside of the LCD Monitor’s synchronous range (Horizontal: 24 ~ 61 KHz and Vertical: 56 ~ 75 Hz), the OSD will display a “*Out of Range*” message. Choose a mode that is supported by your LCD Monitor.

Also, if the signal cable is not connected to LCD monitor at all or properly, the monitor screen will display a message “*No Input Signal*”.