

DRAFT 8-17-17



Synergize[®] RF Network kV2c Field Installation Instructions

Y20466 - TUM
Revision D
www.Aclara.com

DRAFT 8-17-17

Proprietary Notice

This document contains information that is private to Aclara Technologies LLC, an Ohio limited liability company, and/or that is private to Aclara Meters LLC, a Delaware limited liability company (individually or collectively “Aclara”). This information may not be published, reproduced, or otherwise disseminated without the express written authorization of Aclara.

Any software or firmware described in this document is furnished under a license and may be used or copied only in accordance with the terms of such license.

Disclaimer

The information in this document is subject to change without notice and should not be construed as a commitment by Aclara. Aclara assumes no responsibility for any errors that may appear in this document.

No responsibility is assumed for the use or reliability of software on equipment that is not supplied by Aclara.

Metrum Cellular, STAR, Synergize, and TWACS are registered trademarks of Aclara Technologies LLC.

**Aclara Technologies LLC
Confidential and Proprietary
Copyright 2017. All Rights Reserved.**

DRAFT 8-17-17

DRAFT 8-17-17

Warnings, Cautions, and Notes

Always consult and adhere to all local and national safety codes, regulations, and standards. WARNING, CAUTION and Note statements are used throughout this manual to emphasize important and critical information to help you ensure safety and prevent product damage. These statements are defined below.

WARNING



indicates a potentially hazardous situation which, if not avoided, could result in death or serious physical injury.

CAUTION



indicates a situation, which, if not avoided, could result in damage to equipment, damage to software, loss of data or invalid results.

NOTE

indicates important supplemental information.

FCC/IC Compliance

This equipment has been tested and found to comply with the limits for a Class B digital device, pursuant to part 15 of the FCC Rules. These limits are designed to provide reasonable protection against harmful interference in a residential installation. This equipment generates, uses and can radiate radio frequency energy and, if not installed and used in accordance with the instructions, may cause harmful interference to radio communications. However, there is no guarantee that interference will not occur in a particular installation. If this equipment does cause harmful interference to radio or television reception, which can be determined by turning the equipment off and on, the user is encouraged to try to correct the interference by one or more of the following measures:

- Reorient or relocate the receiving antenna.
- Increase the separation between the equipment and receiver.
- Connect the equipment into an outlet on a circuit different from that to which the receiver is connected.
- Consult the dealer or an experienced radio/TV technician for help.

CAUTION

Any changes or modification made to this device without the expressed, written approval of Aclara Technologies LLC may void the user's authority to operate this device.

Antennas

Only the antenna provided with this meter is authorized to be used without approval from Aclara, the FCC, and ISED.

FCC/IC RF Exposure Guide

Aclara Technologies LLC low power RF devices and their antennas must be fixed-mounted on indoor or outdoor permanent structure(s) providing a separation distance of at least 20 cm from all persons during normal operation. This device is not designed to operate in conjunction with any other antennas or transmitters. No other operating instructions for satisfying RF exposure compliance are needed.

Field Calibration Procedure

Aclara Technologies LLC low power RF devices have passed through extensive testing and calibration procedures while in the factory. Therefore, no additional calibration or adjustment is required in the field.

DRAFT 8-17-17

Avertissements, mises en garde et remarques

Toujours consulter et respecter les codes, règlements et normes de sécurité locaux et nationaux. Des AVERTISSEMENTS, MISES EN GARDE et remarques sont utilisés tout au long de ce guide pour souligner l'information importante et critique qui vous aidera à assurer la sécurité et à prévenir les dommages au produit. Ces énoncés sont définis ci-dessous.

AVERTISSEMENT



indique une situation potentiellement dangereuse qui, si elle n'était pas évitée, pourrait entraîner la mort ou des blessures graves.

MISE EN GARDE



indique une situation qui, si elle n'était pas évitée, pourrait entraîner des dommages à l'équipement, des dommages au logiciel, des pertes de données ou des résultats invalides.

REMARQUE indique des informations supplémentaires importantes.

Conformité FCC/IC

Cet équipement a été testé et il est conforme aux limites pour un appareil numérique de Classe B, en vertu de l'article 15 des règlements de la FCC. Ces limites sont conçues pour offrir une protection raisonnable contre l'interférence nuisible dans une installation résidentielle. Cet équipement génère, utilise et peut émettre de l'énergie de fréquences radio et, s'il n'est pas installé ou utilisé conformément aux instructions, il peut causer une interférence nuisible aux communications radio. Il n'existe toutefois aucune garantie que de telles interférences ne se produiront pas dans une installation particulière. Si cet appareil cause des interférences nuisibles à la réception des signaux de radio ou de télévision, ce qui peut être détecté en mettant l'appareil sous et hors tension, l'utilisateur peut tenter de neutraliser l'interférence de l'une ou l'autre des façons suivantes :

- Réorienter ou repositionner l'antenne de réception.
- Augmenter la distance séparant l'équipement du récepteur.
- Brancher l'appareil dans une prise sur un circuit électrique différent de celui sur lequel le récepteur est branché.
- Consulter le fournisseur ou un technicien radio ou télévision expérimenté.

MISE EN GARDE Tout changement ou toute modification à cet appareil sans l'approbation écrite expresse d'Aclara Technologies LLC peut annuler l'autorisation de l'utilisateur d'utiliser cet appareil.

Antennes

L'antenne fournie avec ce compteur est la seule qui puisse être utilisée sans l'approbation d' Aclara, the FCC et l' ISED.

Guide d'exposition aux RF FCC/IC

Les appareils RF à faible puissance Aclara Technologies LLC ainsi que leurs antennes doivent être montés de manière fixe sur des structures intérieures ou extérieures permanentes qui se trouvent à au moins 20 cm des personnes pendant le fonctionnement normal. Cet appareil n'est pas conçu (et il n'a aucun branchement externe) pour être utilisé en association avec toute autre antenne ou tout transmetteur. Aucune autre instruction d'utilisation n'est requise pour assurer la conformité aux règles d'exposition aux RF.

Procédure de calibration sur place

Les appareils RF à faible puissance Aclara Technologies LLC ont été soumis à des tests étendus et multi-tâches et à des procédures de calibration complexes en usine. Par conséquent, ils ne requièrent pas de calibration ni d'ajustement supplémentaire sur place. Les appareils RF à faible puissance Aclara Technologies LLC sont expédiés au client dans des boîtiers scellés. Aucun ajustement ne peut donc être effectué sur place sans briser le boîtier scellé en usine.

Installation Notes

The GE kV2c meter integrated with the Synergize RF module is a plug-for-plug meter replacement designed to be inserted into a number of standard socket meter bases. To install the integrated meter, simply remove the existing meter and insert the integrated meter in its place. Record the final reading of the replaced meter as per standard utility practices.

The blue LED is set to flash on the meter to provide a visual indication that the meter has powered on.

If a time set command is received from at least one DCU with a matching Network ID within 5 minutes of powering up, the blue LED light stops flashing and remains solid for 2 minutes, and then turns off.

However, if the valid time set command is **NOT** received within 5 minutes, the flashing blue LED turns off. If this occurs, note that the Synergize RF module did not make a valid network connection. Try to install another meter at this location. If the condition persists with the second meter record the meter number, and note that the meter was left with a flashing blue LED. Also note if you are unable to successfully install a meter at this location. If you have questions, please contact Aclara Support at support@aclara.com or call 1-800-892-9008.

NOTE You will see the blue LED flashing on the right front side of the meter underneath the meter nameplate.



Upon verification of normal operation, record all appropriate information, including digital register reading, before completing installation.

DRAFT 8-17-17

Installation Instructions

When installing the Synergize RF module, enter the following information into the system:

1. Record the GPS coordinates of the meter face to the sixth (6) decimal place.
2. Record the current date and time.
3. Scan the QR code to enter the meter number, and MAC ID.



4. Take a zoomed-in picture of the meter face.
5. Take a zoomed-out picture of the meter face, including surrounding features.
6. Turn 90 degrees to your right, and take a picture.
7. Turn 90 degrees to your right, and take another picture.
8. Turn 90 degrees to your right, and take one more picture.
9. With your back to the meter face, document the compass direction the meter face is pointing. Record the direction in whole degrees, keeping in mind that north is 0°, east is 90°, south is 180°, and west is 270°.

DRAFT 8-17-17

CAUTIONS In order to avoid damage to the equipment, correct meter-socket wiring should always be verified when installing the meter.

From the meter nameplate, verify that the type, class, voltage, and form are compatible with the installation.

NOTE These instructions assume that an in-range DCU has already been installed, and properly configured with a valid time.

Find the wiring diagram from the following pages that corresponds to the meter being installed. Verify that this wiring diagram matches the meter-socket wiring.

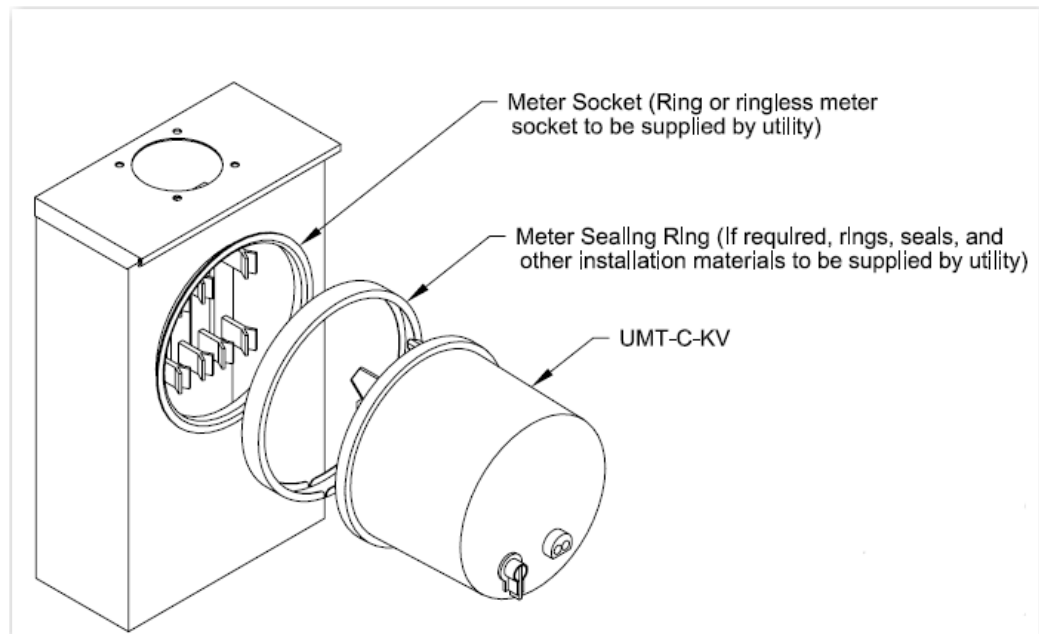

Supported Field Installations

Form 2S

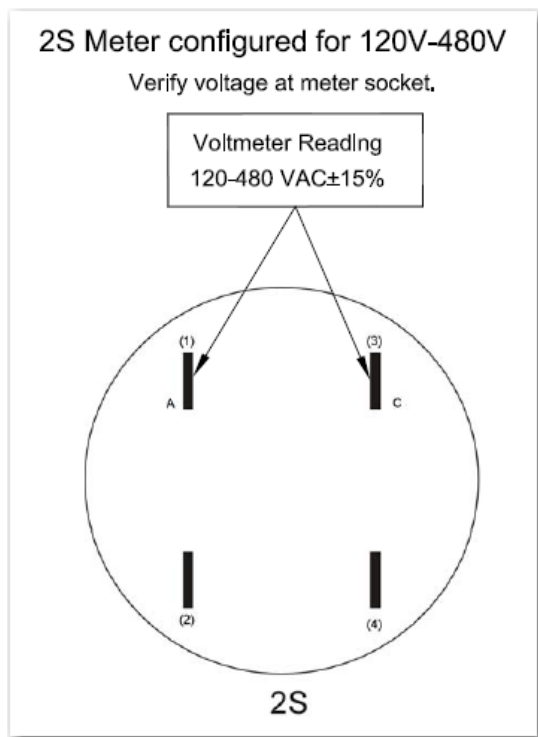

Form 8S/9S

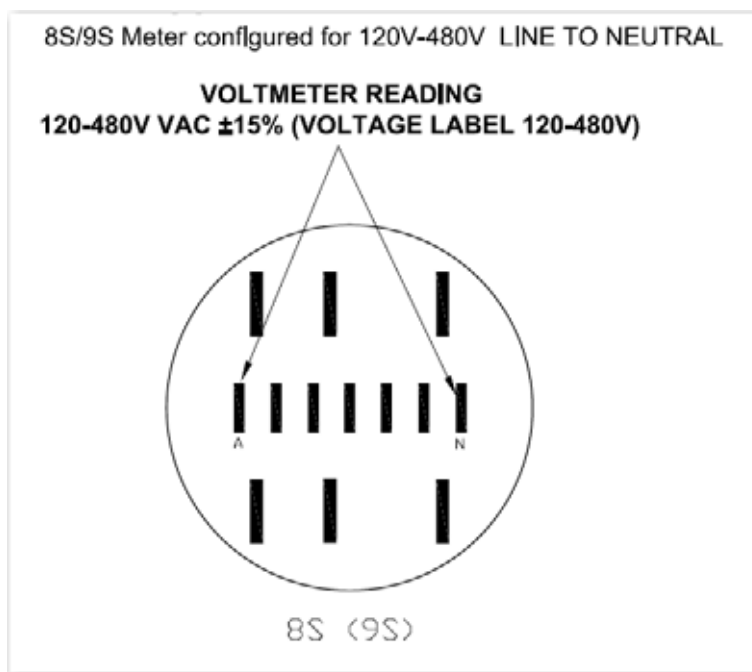

DRAFT 8-17-17

Form 8S/9S (120VT)

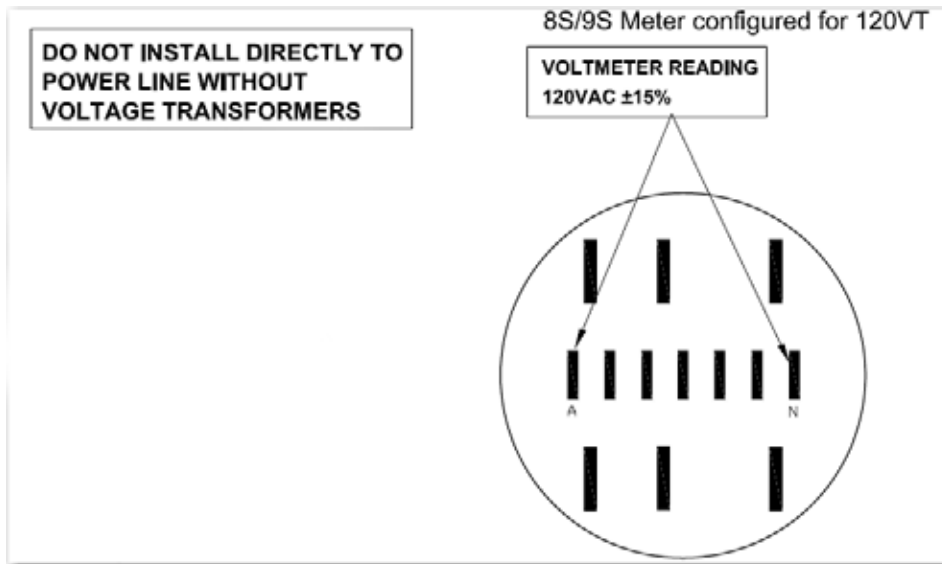

Form 12S/25S

Form 12S and 25S Meter configured for 120 Vrms.
Installed in 3WY circuit.

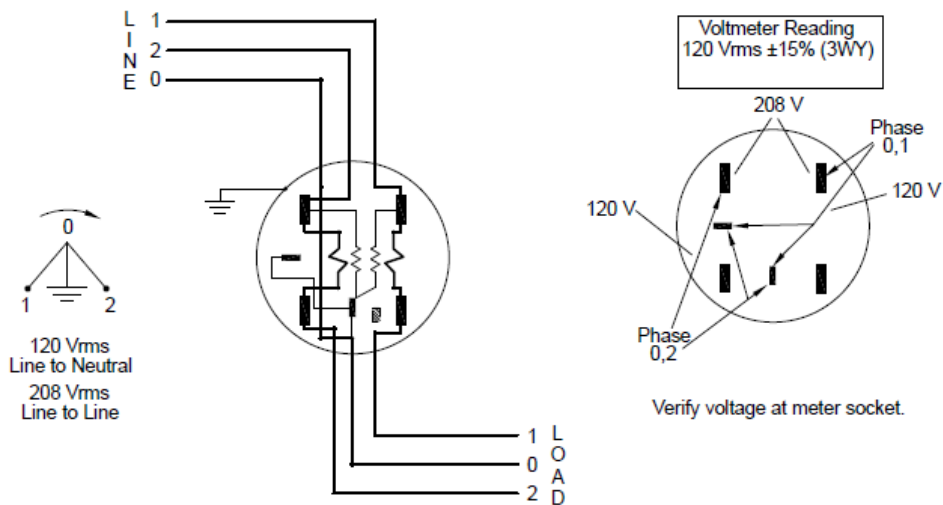

DRAFT 8-17-17

Form 16S

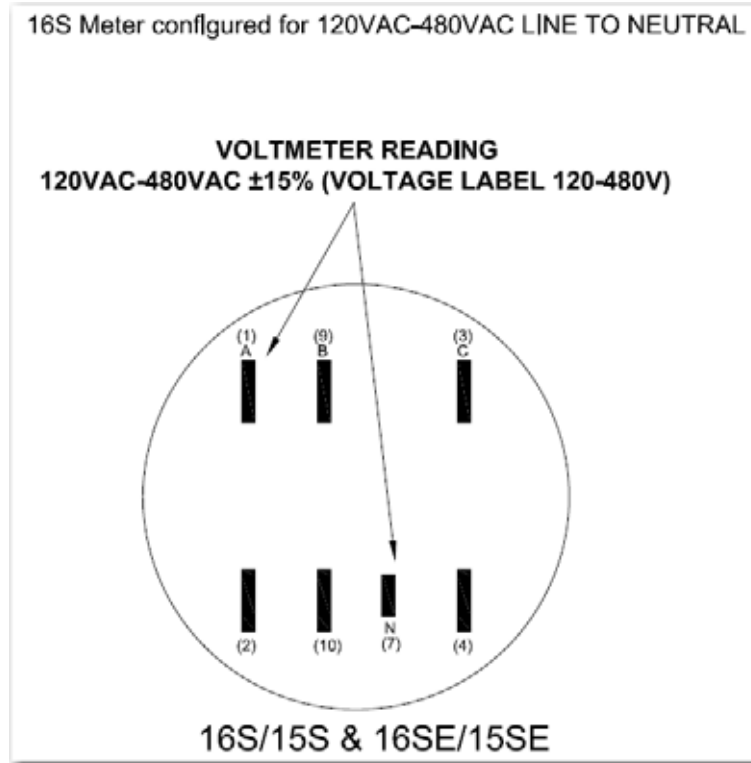

Form 45S

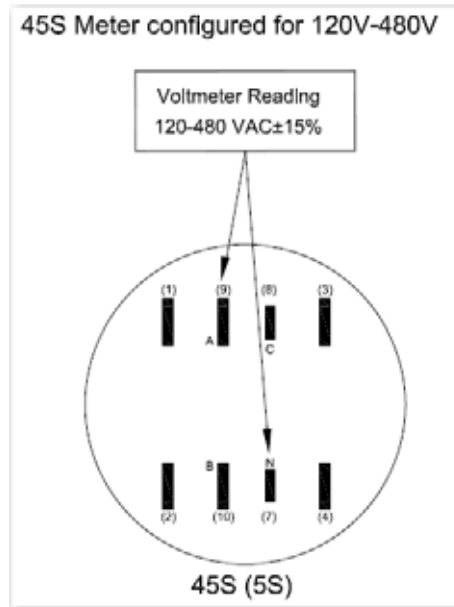

DRAFT 8-17-17

Form 45S (120VT)

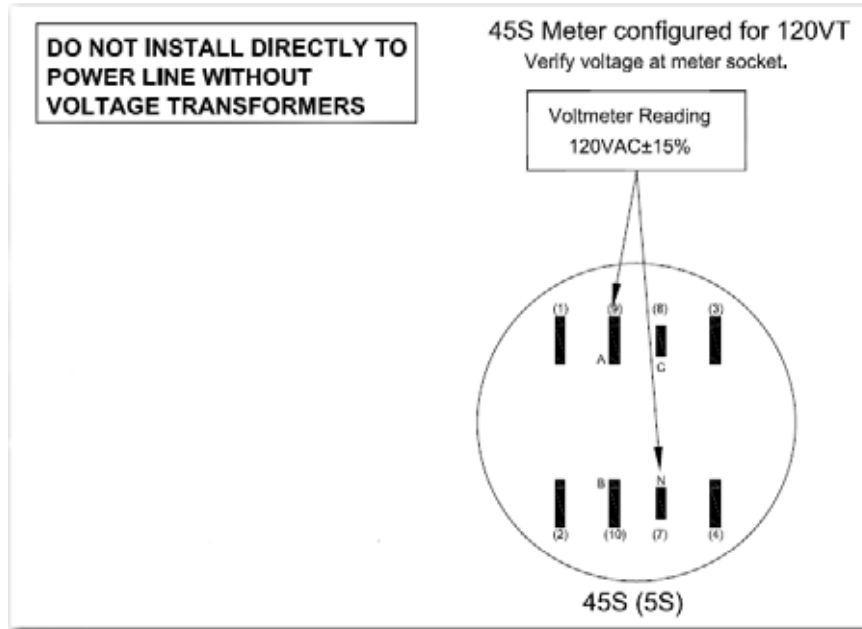

Support

There are several ways to get help when you have a question, an issue, or would like to speak with Aclara's Support personnel.

- Aclara Connect

Aclara's exciting customer portal (<https://connect.aclara.com>) enables you to access our frequently-updated knowledge database, easily access product documentation, submit and track your Support cases and RMAs, access Aclara University's Online Learning Center (OLC) and learning library, track your orders, join communities and groups, join in discussions with other Aclara customers and Aclara personnel, and much more. If you do not have access to Aclara Connect, email support@aclara.com and request access.

- Aclara University

Aclara's on-demand training makes content available to you in a convenient, cost-effective online environment. The OLC has recordings of several webinars, streaming educational videos, software simulations, and short videos which walk you through a specific task. Access the OLC by going the Training tab of Aclara Connect and clicking the Online Learning Center link.

- Technical Support

Email support@aclara.com or call 1-800-892-9008 to speak with an Aclara representative.