



Exhibit 6: User's Manual

**External Radio Frequency
Power Amplifier ACOM 2100**

Model 2100

Table of Contents

1. GENERAL INFORMATION	3
1-1. Introduction and Description	3
1-2. Owner Assistance	3
1-3. Equipment Supplied	3
1-4. Features	3
1-5. Safety Considerations, Explicit Definitions	4
2. INSTALLATION	6
2-1. Unpacking and Initial Inspection	6
2-2. Mains Voltage Selection	6
2-3. Amplifier Location Selection	6
2-4. Connections	7
2-5. Installation of External Fan	8
3. POWER ON, CONTROLS AND INDICATORS	9
4. OPERATION	11
4-1. Turning ON and OFF	11
4-2. Changing Operate and Standby Modes	11
4-3. Antenna change	12
4-4. Tuning	12
4-5. Continuous carrier modes	14
4-6. ON LINE Information Screens and Control Functions	15
4-7. Auto-Protection System	15
5. OFF LINE MODE	16
5-1. Auto-Operate enabling and disabling	16
5-2. Antenna output assignment	16
5-3. Reading Auto-protection Signatures	16

6. MAINTENANCE.....	17
6-1. Cleaning.....	17
6-2. Fuse Replacement.....	17
6-3. Tube Replacement.....	17
6-4. The ACOM2100 Simplified Schematic Diagram.....	17
6-5. Troubleshooting.....	18
7. SPECIFICATIONS.....	20
7-1. Parameters.....	20
7-2. Functions.....	20
7-3. Storage and Shipment.....	21

1. GENERAL INFORMATION

1-1. Introduction and Description

This manual explains the installation, operation, and maintenance of the ACOM2100 HF+6 meter linear amplifier.

The ACOM2100 is a complete and self-contained linear amplifier that covers all amateur bands from 1.8 through 54MHz and provides over 1500W PEP or continuous carrier output power with less than 85W exciter drive. Antenna VSWR up to 3:1 is acceptable with 1500W forward power. Tuning is substantially simplified by a plate-load True Resistance Indicator (TRI) and by an automatically controlled input attenuator. Operating parameters are displayed by a multi-functional high brightness and contrast OLED display. Full break-in transmit/receive switching (QSK) is standard.

1-2. Owner Assistance

If assistance is needed, you should contact your local dealer first. If you still have an issue you need to discuss with one of ACOM's specialists, the contact information is as follows: fax + 359 2 920 96 56, tel. + 359 2 920 96 55, e-mail acom@mail.orbitel.bg, acom@acom-bg.com, WEB: www.acom-bg.com or by mail: ACOM OOD, Blvd. Nikola Mushanov 151, 1330 Sofia, Bulgaria.

1-3. Equipment Supplied

The ACOM2100 amplifier and this manual are shipped in two cardboard cartons. One carton contains the power transformer; the second carton contains the amplifier.

1-4. Features

■ Easy to operate. The TRI is a powerful tuning aid that, together with the 2:1 TUNE and LOAD caps verniers and the automatically controlled input attenuator, helps the operator to quickly and precisely match the antenna impedance to the optimum tube load impedance (5-10 seconds typically). The auto-operate function (when enabled) maintains the amplifier in the OPERATE mode for you, thus avoiding unnecessary manual operations.

■ No heavy outboard antenna tuners required for antenna VSWRs up to about 3:1. Your amplifier will enable you to change antennas virtually instantaneously and allow you to use your antennas over wider frequency ranges.

■ An amplifier that is both user-friendly and that looks after itself. It is designed to safely withstand up to 400W reflected power, up to 100 milliseconds duration of drive spikes, drive RF "tails" after a PTT or KEY release, operator's inadvertent tuning errors etc. The amplifier also will not cease to function with a "soft" AC mains and will deliver more than half power at only 85% of nominal mains voltage. It can withstand voltage drops (down to zero Volts) for up to 10 milliseconds and can tolerate 15% mains voltage spikes, which is especially important on Field Day, during DXpeditions, and at portable operating events where emergency power is relied upon.

■ OLED information display. All amplifier status indications are explained via detailed text displayed on the dot matrix, high brightness and contrast OLED display. The upper line on the OLED always reads peak forward power. LED indicators are provided for: OPERATE mode, attenuation-on (ATT), transmit (TX), selected antenna output (1, 2, or 3), and ON/OFF conditions.

■ Antenna selection. Three antenna outputs are selectable using a push-button on the front panel.

■ Easy maintenance. Data regarding amplifier internal status is stored in a nonvolatile memory for 7 of the most recent auto protection trips. This information can be forwarded to your dealer for diagnostics.

Using an Excel application, available from ACOM or your dealer free of charge, and a PC you can decode the status data by yourself.

- Less noise in the shack. The input bypassing and vacuum antenna relays are virtually silent even in the CW QSK mode thanks to specially designed mounting hardware.
- Less QRM and improved Electro Magnetic Compatibility during tuning. Amplifier tuning can be achieved in less than 10 seconds at a quarter of nominal output power.
- Operates without special signals from the transceiver. "Ground on TX" (PTT) and 85W RF drive power are sufficient.
- Broadband input matching circuit design provides excellent transceiver loading over the entire spectrum, from 1.8MHz up to 54MHz.
- Uses a single 4CX1000A/8168 ceramic and metal radial beam tetrode with plate dissipation of 1000W (forced air cooled, grid-driven), which is specifically designed for class AB1 RF linear amplifier operation.
- Permanent monitoring includes protection of plate and grid voltages and currents, as well as exhaust air temperature. The Bias Optimizer decreases the heat dissipated from the tube, and there is automatic protection against overheating in accordance with specifications of the tube manufacturer.
- Output RF arc protection is employed. This important feature safeguards the amplifier, antenna, antenna selector, and tuner against severe damage in case of possible breakdown.
- High voltage power supply inrush current limitation. This feature reduces the risk to sensitive devices connected to the same mains circuit (important when used portable) when the amplifier is turned on. The amplifier can be configured for 8 nominal mains voltages: 100, 110, 120, 200, 210, 220, 230, and 240VAC, 50 or 60Hz.
- Continuous monitoring and/or selectable measurement of the 12 most important parameters of the amplifier, exciter, and the selected antenna via the OLED.

1-5. Safety Considerations, Explicit Definitions

The ACOM2100 HF + 6 meters Linear Amplifier is a Safety Class I unit. The third grounding lead of its mains cord (colored yellow with two green stripes) and the ground stud on the rear panel of the amplifier (marked GND) should be connected to the station's grounding system for safe operation.

The amplifier is designed to meet international safety standards and complies with UL and CE safety and electromagnetic compatibility requirements, as well as FCC regulations.

This operating manual contains information, precautions, indications for cautions and warnings that must be followed by the user to assure safe operation and to keep the ACOM2100 operating properly.

PRECAUTIONS:

The EXPLICIT DEFINITIONS described below apply to this operating manual:

WARNING notes call attention to a procedure which, if not correctly performed, could result in personal injury, fire hazard or electric shock.

CAUTION notes call attention to a procedure which, if not correctly performed, could result in equipment damage, not only in the amplifier.

NOTE notes call attention to a procedure which, if not correctly performed, could result in inconvenience.

WARNING HIGH VOLTAGE!

The amplifier works with high voltages above 3000V, which are LETHAL! Also, for your safety, pull the amplifier power plug out of the mains wall outlet and WAIT AT LEAST 30 minutes EACH TIME BEFORE you remove the cover of the amplifier. Do not touch any part inside while the amplifier is open because some residual voltages may still be present.

WARNING HIGH VOLTAGE!

NEVER ALLOW ANYONE, ESPECIALLY CHILDREN, to push anything into holes in the case - this will cause electric shock. NEVER TOUCH AN ANTENNA during transmission - this may result in an electric shock or burn. NEVER EXPOSE the amplifier to rain, snow or any liquids. AVOID placing the amplifier in excessively dusty environments or in direct sunlight. DO NOT OBSTRUCT AIR INTAKE (rear panel) and EXHAUST (top cover) areas of the amplifier. Keep a minimum distance of 10cm (4 inches) to the intake and 50cm (20 inches) to the exhaust openings.

WARNING

Do not undertake your own repairs or changes in hardware or software of the amplifier. Doing so will endanger your or others' health or life or damage the amplifier and the equipment connected to it. Such repairs or changes are not covered by warranty and may void the warranty. The manufacturer is not liable for any such repairs or changes. Any such repairs or changes are strictly the responsibility of the person or persons engaging therein.

CAUTION

To avoid damage (not covered under warranty) read the Installation - Section 2 of this operating manual carefully. If you have any doubts or questions regarding the installation, operation or safety of the amplifier, please consult your dealer immediately.

2. INSTALLATION

2-1. Unpacking and Initial Inspection

NOTE

Before you install your amplifier, thoroughly read this manual. First, carefully inspect the cardboard cartons and their contents for physical damage. If damage is evident, notify your dealer immediately. Delay may void the carrier's warranty. Keep all packing materials for possible future amplifier shipment.

2-2. Mains Voltage Selection

CAUTION

To avoid damage, which will not be covered under your warranty, check carefully to be certain that the voltage for which the amplifier is set corresponds to your mains nominal voltage.

Normally, the amplifier is supplied set for a nominal mains voltage of 240V. If your mains voltage is not 240V, you must contact your dealer for instructions on how to change the voltage selector inside the amplifier. The only exception to this is if the unit has been custom ordered, in which case the voltage selection will be noted in the Table of Individual Data (Table 2-1, below).

AMP s/n	[REDACTED]
Tube s/n	[REDACTED]
Voltage Selector	[REDACTED] VAC

Table 2-1. ACOM 2100 Individual Data

CAUTION

The current consumed by the amplifier from the mains supply should not exceed 16A from 200/240VAC and 20A from 100/120VAC. You will have to reduce the output power to about 1000W PEP if the amplifier is operated at 120V or lower mains supply voltage.

2-3. Amplifier Location Selection

CAUTION

The weight of the unit is about 29.3kg (64.6Lbs), which should be handled by two persons.

Position the amplifier near where it will be used. You will need an easy access to the command knobs and indicator's area, as well as to the rear panel cabling.

No magnetic-field sensitive devices (such as microphones) should be located next to the right side of the amplifier because its power transformer is located there. It is advisable to position the amplifier to the right of your transceiver. No temperature-sensitive devices should be located above the exhaust hot air area. Do not locate the amplifier under a shelf, for example. **DO NOT UNDER ANY CIRCUMSTANCES OBSTRUCT the AIR INTAKE (rear panel) or EXHAUST (top cover) areas of the amplifier.** Keep a minimum clearance distance of 10cm (4 inches) from the intake and 50cm (20 inches) from the exhaust openings.

NOTE

If the power transformer is not readily installed check the Transformer installation leaflet supplied with it.

2-4. Connections

Connection to your station must be accomplished in the order described below before you apply mains voltage to the amplifier.

WARNING

Note that the grounding system may have to withstand currents over 20A with minimal voltage drop. Therefore, it may be necessary to improve grounding system conductivity with heavier conductors and a lower-resistance ground path. The grounding conductor should be at least 8mm² (AWG 8 or SWG 10).

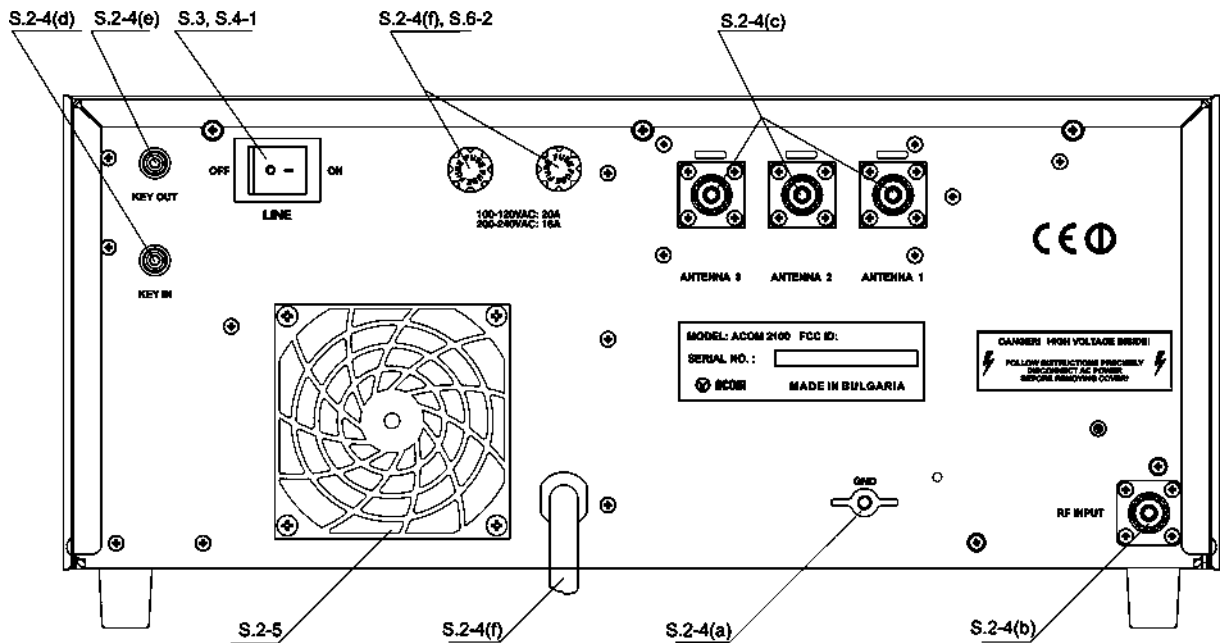

Fig. 2-1 Connections

- a) First, connect the ground stud of the amplifier (on the rear panel, marked GND) to the station's grounding system (Fig.2-1).
- b) Connect a coaxial cable with a PL-259 plug from the transceiver output to the amplifier rear panel RF INPUT socket.

CAUTION

If this is the first time you are using a power amplifier in your station, pay close attention to the coaxial cable type from the amplifier's three outputs. The cable must be capable of handling the increased power levels, particularly on the 10m and 6m bands. We recommend that you use RG213 or better coaxial cables. Consult your local cable supplier for the appropriate cable selection. This caution applies equally to the antenna selector, tuner and antennas system as well.

- c) Connect a suitable coaxial cable from your antennas to the appropriate amplifier output on the rear panel, marked ANTENNA 1, ANTENNA 2, and ANTENNA 3, using PL-259 plugs with PTFE insulation.
- d) Run a cable terminated with a phono (RCA) connector from the transceiver socket providing a "ground on transmit" (PTT) control signal to the amplifier rear panel KEY-IN socket.

NOTE

Your amplifier will not work if KEY-IN is not connected properly.

Transceiver producers give different names to this output, such as TX-GND, SEND, T/R-LINE, PTT, etc. Some transceivers require that "ground on transmit" be implemented via a software command, or by changing the setting of a switch on the rear panel or in the interior of the transceiver. Check your transceiver manual. Consult with your dealer if you are having difficulty.

The switching voltage presented from amplifier KEY-IN socket to the transceiver "ground on transmit" output does not exceed 13V (positive to the ground). The closed-circuit current is below 5mA.

e) The KEY-OUT socket on the rear panel provides an extra control signal from the amplifier to the transceiver. It can be used to improve the transmit/receive switching safety. The rating on this output is very low current, so be certain that the load will not exceed 50VDC when it is open circuit and 20mA when it is closed.

If your transceiver has a suitable input that disables transmission, we recommend that you connect it with a cable terminated in a phono (RCA) connector to the KEY-OUT socket of the amplifier. Transceiver producers give different names to this input and they are for instance TX-INHIBIT, MUTE, LINEAR, etc. Check your transceiver manual.

Your amplifier will function normally if the KEY-OUT remains unused.

f) Preparation of wall outlet for the amplifier.

WARNING

If your amplifier is only fitted with one mains fuse, it is suitable for the European Union ONLY. Your dealer will check that your amplifier is correctly fused before it is shipped to you, based upon your indicated location. Customers should check with a qualified electrician if the amplifier is to be used outside the country for which it was purchased.

Your dealer will fit the correct mains plug for your country, and will check that the amplifier is correctly set for the mains network applying there. If the amplifier is to be connected to the mains network in another country, check with your dealer or a qualified local electrician before use there.

WARNING

Before connecting the amplifier to your mains supply, be sure that the supply is correctly wired, and that it is adequate for the current drawn by the amplifier - up to 16A from 200/240V and 20A from 100/120V. Make certain that the grounding lead is connected properly in the wall outlet used for the amplifier.

It is preferable that you use a wall outlet close to the power source. The power cord leads and associated wiring should be at least 2.5mm² (AWG 13 or SWG 15). Check if the respective fuses can handle current up to 16A (20A for 120VAC) as well, and whether the voltage corresponds to the voltage for which the amplifier is set (S.2-2). If you connect the amplifier to a different mains outlet, be sure that you check it as well.

Make sure the main Power Switch on the rear panel is in the OFF position and insert the amplifier's mains plug into the wall outlet prepared for it. The amplifier remains switched off at this time.

2-5. Installation of External Fan

This fan (Fig. 2-1) is not necessary in SSB and CW modes, or in continuous carrier modes (RTTY, SSTV etc.) with a maximum carrier-down time of 5 minutes and a subsequent pause of 3 minutes. For higher duty cycles such as continuous broadcast or increased ambient temperatures the fan is recommended. The auxiliary fan (92x92x25mm or 92x92x38mm) must be a brushless type, 2...5W/24VDC. It may be installed by your dealer or by the manufacturer on request.

3. POWER ON, CONTROLS AND INDICATORS

CAUTION

Do not turn the amplifier on for at least 2 hours after unpacking it in the room where it will be used. Pay particular attention when you move it from a very cold into a warm place - condensation is likely and this could result in damage to the high voltage circuits. In such a case, wait at least 4 hours. A similar effect can occur after a rapid warming of the operating room (for instance after switching on a powerful heater in a cold shack).

CAUTION

To avoid damage (not covered under warranty) carefully check that the voltage for which the amplifier is set corresponds to your mains nominal voltage (see S.2- 2 and table 2-1).

After following all instructions in S.2, you may turn ON the main power switch marked "LINE" on the rear panel (Fig.2-1). The LED indicator above the red ON/OFF button located on the front panel must light red and an inscription "ACOM2100" will appear on the display (Fig.3-1):

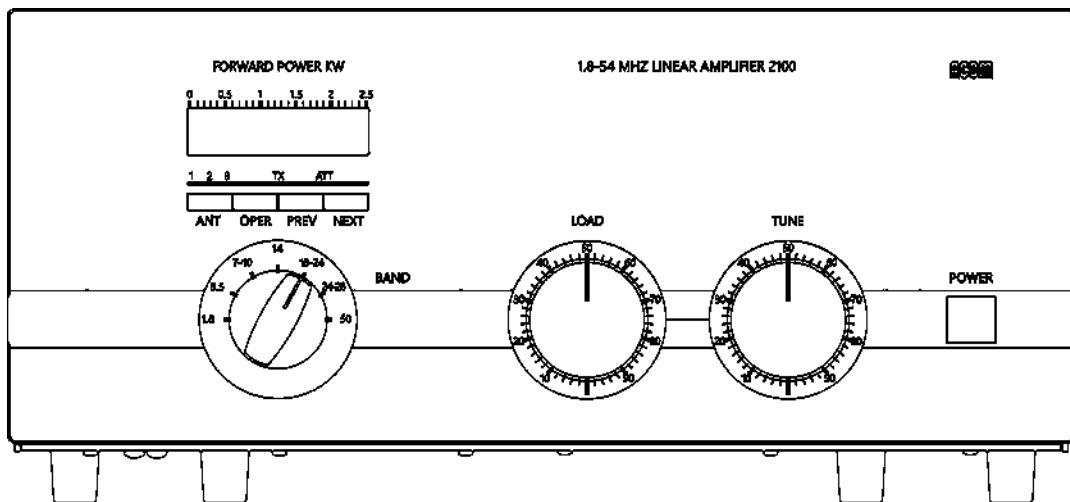

Fig.3-1 ACOM2100 Display and Control

Note that the upper line of the OLED always reads the peak forward power, even in STBY mode. The 2400W scale resolution is 20W per bar. Note too that levels below 50W may be not detected.

In this position (called OFF LINE hereafter), only the micro-controller is operational, while the amplifier itself is still turned off (and the tube is not powered at all).

Control of the amplifier is accessible during OFF LINE and ON LINE (OPERATION) states, each having several information screens and control functions (see Fig. 3-2):

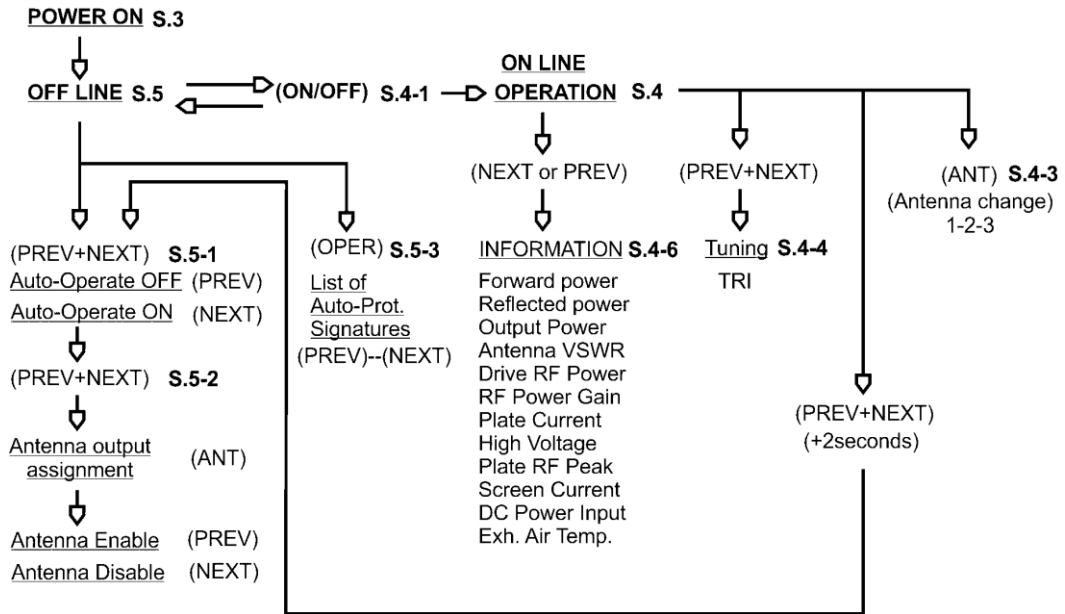

Fig.3-2 Information Screens and Control Functions Structure

The OPER button changes operate and standby modes alternatively (S.4-2) while ON LINE. Please note that Auto-Operate might be enabled (S.5-2). The same button activates signature list while OFF LINE (S.5-3).

The PREV and NEXT buttons change information screens or select control functions (S. 4-6) for both OFF LINE and ON LINE modes.

The ON/OFF button switches OFF LINE and ON LINE (OPERATION) states of the amplifier alternatively.

You can proceed in one of two ways:

- a) You may use the OFF LINE information screens and control functions. They refer to the auto-protection signatures list, as well as the Auto-Operate feature and Antenna assignment. This is described in S5.
- b) You may turn on the amplifier and start the warm-up sequence. After 3 minutes you may tune and begin operating the amplifier and you can use the ON LINE (OPERATION) information screens or control functions (see below).

4. OPERATION

Operation of the amplifier is simplified through use of the TRI tuning aid, Auto-Operate function, and automatic protection system, so you may begin using the amplifier immediately following installation. However, to make full use of the amplifier's potential and to fully configure it to your local conditions, we recommend that you thoroughly read the following information.

There are 14 ON LINE information screens, which can be selected by pressing repeatedly the NEXT or PREV buttons (see fig.3-2). Their purposes and methods of use are described in the next 7 sections, 4-1 through 4-7.

4-1. Turning ON and OFF

In order to turn on the amplifier while the Main Power Switch (located on the rear panel) is on, press the red ON/OFF button (located under the red LED on the front panel right-bottom corner) and hold it on for about one second. The OLED will light and the ON/OFF LED indicator above the button will change the color from red to green. You will hear the blower and the optional external fan starting at high speed for a second and then slowing down.

After successfully passing the initial amplifier self-tests, the ON/OFF LED begins flashing green while the following inscription on the OLED remains lit:

WARMING UP: nnn s

(nnn above is the number of seconds remaining to readiness for operation)

A tube warm-up period of 180 seconds (3 minutes) follows. During this time the amplifier remains in standby mode, so you can continue operating with the transceiver.

Pressing either the PREV or NEXT buttons during this period will result in changing the screen to one of the 14 available information screens described in S.4-6 below. This will not influence the warming-up process, so you may pass through all information screens, to monitor the High Voltage value or the Exhaust Air temperature, for example. You may also return to the earlier screen to see how many seconds are still needed until the tube cathode reaches its operating temperature.

NOTE

When you intend to have a short operating break, it is better to leave the amplifier in standby mode instead of turning it off. Tube life is shortened by repeatedly turning on and off the heater filament. However, if you unintentionally power-off the amplifier, it is best to switch it on again immediately. When the pause is short (up to one minute) and the cathode is still warm, the warm-up period is shortened significantly, which reduces the waiting time and prolongs the tube's life.

After the indicated period expires, the ON/OFF button stops flashing and lights green constantly. If the auto-operate function has been selected to ON (see S.5-1), the green OPER LED will illuminate automatically. The last used (one out of 14) information screen appears on the display, e.g., "WARMING UP: Ready."

The bar-graph on the upper line always indicates the peak forward power (as well as during OFF LINE).

In order to turn the amplifier off, press the red ON/OFF button. If you intend to have a break for a long time, it is best to turn it off using the Main Power Switch (on the rear panel) as well.

4-2. Changing Operate and Standby Modes

With the Auto-Operate function disabled (see S.5-1), the OPER button changes two modes alternatively.

When Auto-Operate is enabled, the amplifier will be maintained in operate mode by default, unless you use the OPER button manually to go to standby (in which case the Auto-Operate is suppressed temporarily). Pressing OPER again will restore the Auto-Operate feature.

When the Auto Operate function is disabled, the amplifier will shift and stay in STBY mode after each protection trip. To restore operation, the OPER button must be depressed.

When the Auto Operate function is enabled (see S 5-1), the amplifier will shift to the STBY mode on a protection trip. It will return to the OPER mode after about four seconds automatically.

4-3. Antenna change

By pressing the ANT button, the amplifier output can be switched between three antenna outputs. The three lights above the button indicate the current antenna selection. Selection of any of the antenna outputs can be disabled if not used - see S. 5-2 - Antenna outputs assignment. This prevents inadvertent selection of antenna outputs, preventing no-load transmission and possible amplifier damage.

CAUTION

To avoid damage (not covered under warranty) do not change antennas while transmitting. Do not transmit into an antenna output (1, 2, or 3) if it is not connected to an antenna or a dummy load.

4-4. Tuning

Tuning is possible only in operate mode, so you may need to press the OPER button in order to illuminate the LED above it (unless Auto-Operate is active).

a) Preliminary information.

Tuning the amplifier is a procedure of matching the impedance of the currently used antenna to the optimum tube load resistance. This will ensure optimum plate efficiency and RF gain at nominal output power, with minimum resulting IMD.

Please note, that the REFLECTED POWER readings and the measured VSWR depend on the antenna impedance only, and not on the amplifier tuning. If the antenna impedance is different from 50-Ohm pure resistive (nominal), the REFLECTED POWER reading will always indicate some reflected power (even with optimal tuning). Proper tuning will assure operation at maximum power without distortion or danger to the amplifier.

Note also that the real OUTPUT POWER in the load is equal to the difference between the FORWARD- and REFLECTED- readings. For instance, at a reading of FORWARD 1500W and REFLECTED 250W, the real OUTPUT POWER will be equal to their difference - 1250W (into a 2.4:1 VSWR load). At a very high VSWR (no antenna or badly mismatched antenna), the FORWARD and REFLECTED readings will be almost equal, while the real OUTPUT POWER (the difference between them) will be practically zero.

The amplifier can operate safely if the following rule is obeyed: "REFLECTED POWER < 400W." Matching is assured for loads with VSWR up to 3:1. Nevertheless, for some loads and bands, matching is possible at even higher VSWR figures. The maximum usable forward power at a VSWR of 3:1 is 1500W with 375W reflected. For higher than 400W reflected power a ** REFLECTED POWER ** soft-fault protection trip will occur.

CAUTION

Using a coaxial cable with VSWR > 3:1 on HF, and particularly on the 10 and 6 meters bands, is not recommended. At such high values of VSWR, the high voltages, high currents, and heat associated with line losses risk permanent damage to your coaxial cable or antenna switch.

Adjust amplifier tuning when you change the band or between CW and SSB segments within the same band. Readjust it each time when you change the antenna, even in the same band, as well as periodically, even though you may have not changed band or antenna. A significant change in the environment, such as rain, snow, ice, new or removed large metallic objects, alien wires nearby etc., can cause significant changes in the antenna impedance and an increased VSWR.

NOTE

If you use more than one antenna per band, it is necessary that you select the proper antenna BEFORE the next step. Retune after selecting a different antenna for the same band, since the impedances may differ substantially (unless their VSWRs are excellent, i.e., below 1.2:1 for both).

CAUTION

Do not switch the BAND switch knob while transmitting with the amplifier! Such hot switching will eventually destroy the band switch, and this is not covered by the warranty!

CAUTION

When tuning, do not apply continuous drive longer than one minute and after that pause 1-2 minutes for tube cooling.

We recommend that you tune-up at the center frequencies of the preferred frequency band. First, select the band switch and the correct antenna number (never with RF applied!). Then, use table 4-1 in order to achieve an approximate preset for both TUNE capacitor and LOAD capacitor knobs:

Band, MHz	Tune Knob Dial	Load Knob Dial
1.8 - 2		
3.5 - 4		
7 - 7.3		
10.1 - 10.2		
14 - 14.35		
18 - 18.2		
21 - 21.45		
24.9 - 25		
28 - 29.7		
50 - 54		

Table 4-1. Approximate tuning presets

b) Selecting the plate-load True Resistance Indicator (TRI) tuning aid.

You may select the TRI scale in three different ways:

- By briefly pressing simultaneously the PREV+NEXT buttons. This will insert a 6dB attenuator between the driver and the amplifier's input (the ATT LED will light), removing the need to reduce the drive power during tuning. Press PREV+NEXT buttons momentarily again to switch the attenuator out of the input circuit and to return to the earlier screen. If you use any of PREV or NEXT buttons, the attenuator will be switched off too, but the information screen will change.

- By pressing repeatedly either the PREV or NEXT button until you reach the TRI scale. This will not insert the attenuator, so you must be careful to use less than 20W drive (unless the amplifier is near correct tuning); otherwise the next step will be executed automatically:

- By simply applying a normal (50-85W) drive level while the amplifier is not yet tuned. This will automatically invoke the TRI tuning aid and will insert the input attenuator (the ATT LED will light) after one second. The attenuator will be switched off, and the old screen will be returned automatically, after PTT is released. If near-optimal tuning is achieved, the attenuator will not be inserted again. If the old screen was unchanged (TRI, selected manually earlier), it will be possible to precisely tune the amplifier at nominal power without changing drive at all. Use this approach to shorten the tuning process duration.

c) Tuning Procedure.

While a continuous carrier (CW key down, RTTY or FM) signal at the desired frequency is still applied:

- Look at the upper scale (forward power); obtain maximum power using the upper (TUNE) knob;
- Look at the lower (Load Cap) scale and turn the lower (LOAD) knob in order to center the triangle marker at the "!" mark.
- Release the PTT briefly in order to disable the attenuator, then repeat both steps at nominal power. Always finish by peaking with the TUNE knob.

NOTE

Appearance of an arrow on either left or right TRI scale edges means that the LOAD knob position is far off. To correct this, turn the LOAD knob to the prompted direction until the triangle marker appears inside the scale field.

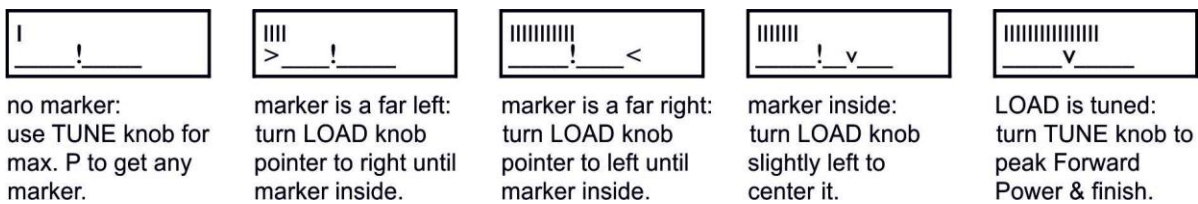

Fig. 4-1. Using TRI tuning aid

Please note that the TRI mark will not appear until at least 5W drive is applied, and at least 20W forward power is achieved.

If, for some reason, matching cannot be accomplished successfully, check the BAND switch position and proper antenna selection. Then check the antenna VSWR at the same drive frequency.

d) Tuning hints.

While turning the knobs, note that both tunings would be virtually independent. This is a benefit of the TRI. The plate-load resistance increases to the right and decreases to the left of the TRI center.

The scale center corresponds to the proper LOAD capacitor tuning, which presents an optimum load resistance to the tube.

If you tune to the right, more gain will be obtained but less undistorted output power will be attainable. You may prefer to use this tuning approach when your drive power is insufficient or when you need less output but better efficiency, for instance at heavy duty modes (RTTY, SSTV etc.) where less heat is wanted (not only in the amplifier but also in the transceiver).

Tuning to the left of the center would lead to the opposite: less gain and more power attainable. Of course, this requires more drive power, more plate current, and more plate heat, which shortens the tubes-expected life, as its cathode would be exhausted more quickly.

You might use the above off-center tuning hint also to compensate for mains voltage variations in order to maintain tube efficiency: tune to the right when mains is higher, or tune to the left if it is lower than the nominal voltage. Please see S.2-2 (Mains Voltage Selection) for more than 5% deviation.

4-5. Continuous carrier modes

The maximum output power in continuous carrier modes such as RTTY etc. is 1500W. You may exceed this limit for short periods (one minute or less), while adjusting the drive power for instance. Please have in mind, however, that the mean output power should not exceed 1500W for longer periods.

For prolonged transmissions the amplifier gain can drop between 5% and 10% during the first minute which is normal while temperature balance of the tube is achieved. You can easily compensate this by

increasing the drive power slightly. Once the drive power has been set, the output power remains stable with the time for hours.

CAUTION

For transmissions longer than 5 minutes the external auxiliary fan must be installed (see S.2-5).

4-6. ON LINE Information Screens and Control Functions

a) Besides the Warming Up and TRI (described above in S.4-1 and S.4-4), you have 12 more Information screens available. They are as follows: Forward Power, Reflected Power, Output Power (difference between forward and reflected), Antenna VSWR, Drive RF Power, RF Power Gain, Plate Current, High Voltage, Plate RF Peak, Screen Current, DC Power Input (product of plate current and high voltage), and Exhaust Air Temperature (Celsius and Fahrenheit scales). You can use them to monitor the technical state of the amplifier and associated parameters, in a digital form.

Selection is made by the PREV and NEXT buttons. You may change the information screens while the amplifier is used and controlled in operate and standby modes, changes transmit and receive, without any influence by the measurement process.

b) You can control the Auto-Operate feature and antenna output assignments while ON LINE. In order to enter the control menu, press the PREV+NEXT buttons simultaneously and hold them for two seconds. Further proceed as described for OFF LINE mode below - see S.5-1 and S.5-2 for details.

4-7. Auto-Protection System

When any abnormal condition is detected, the amplifier will evaluate the risk and may use three different degrees of protection, depending on the nature of the problem. Each event is accompanied by descriptive text.

a) The first degree of protection consists of a warning message only and does not interrupt transmission. Examples include "Reduce Drive", "Plate Current", etc. You may continue to transmit under such conditions but you are close to a trip threshold.

b) The second degree of protection is a trip to standby mode (Soft Fault). An example is ** GRID CURRENT **. All Soft-Fault messages are marked with two asterisks on both screen edges. The message remains on the display until any button is pressed or until the auto-operate function returns to "operate mode" automatically. The Soft Faults permit correction by the user, such as by using less drive, improving antenna VSWR, etc.

c) The third degree of protection is a trip to OFF LINE mode (Auto-Protection). See S.6-5 - Troubleshooting. If it is not evident why the trip has occurred, you may try to turn the amplifier on again. If the problem persists, you will need to contact your dealer - see S.1-2.

NOTE

The 6dB input attenuator is automatically inserted about one second after faulty tuning is detected at drive levels above 20W. It is also switched off at every PTT release (unless inserted manually).

5. OFF LINE MODE

There are two control functions and 14 information screens available in the Off Line Mode of the amplifier. You may enable/disable the Auto-Operate feature and assign the antenna outputs. You may also list the auto-protection signatures. The tube is not powered at all (only the micro-controller is active) during these operations.

5-1. Auto-Operate enabling and disabling

When enabled, this function will maintain the amplifier in OPER MODE automatically - see also S.4-2. The OPER button will be still functional, so you can change to STANDBY and return to OPERATE manually at any time. The auto-operate function will be disabled temporarily when you enter the STANDBY mode but it will be restored after you return to OPERATE by depressing the OPER button.

In OFF LINE mode you may press the PREV+NEXT buttons in order to enable or disable the Auto-Operate feature. The "Auto Operate = ..." screen will appear on the bottom line. Use the PREV button to select OFF or the NEXT button to select ON.

Briefly press the PREV+NEXT buttons again in order to reach the antenna outputs assignment (see the next S. 5-2). Alternatively, you may leave the buttons unused for 20 seconds. In any case, the selections made so far will be retained in the amplifier's memory.

5-2. Antenna output assignment

If there is no antenna connected to an antenna output then the output should be disabled. This will make the switching between two available antennas easier and, more important, it will prevent potentially damaging the amplifier by no-load transmissions.

In order to enable or disable an antenna output, briefly press PREV+NEXT buttons successively until the "Ant:(1-...) 2-...3-..." screen appears. Using the ANT button, move the brackets to enclose the antenna output you want to disable or enable. Press the PREV button to disable or NEXT to enable it. Press PREV+NEXT briefly again to confirm the antenna output assignments and then leave the menu.

NOTE

All selections you make are stored in the amplifier nonvolatile memory. If no button is pressed for 20 seconds, the selections made so far are accepted and the control function is left automatically.

5-3. Reading Auto-protection Signatures

On every Hard Fault protection trip of the amplifier, signature information is stored in its nonvolatile memory. The 7 most recent auto-protection trip signatures are stored there, which may be forwarded to your dealer for diagnostics.

In order to read the trip signatures, press the OPER button while OFF LINE. The display will illuminate at full brightness and the beginning of the signatures list will appear. Use NEXT and PREV buttons to navigate through the 7 pairs of screens. For each auto-protection trip there is a pair of information screens, beginning with nA... and nB... where:

- "n" is the successive number of the event (nr.1 is the latest, nr.7 is the oldest one);
- A and B mark the first and second parts of an information screen pair.

Two lines, three groups by six symbols (36 symbols in total) are to be copied concerning every one of the 7 memorized events, from 1A-1B through 7A-7B.

To decode the signatures please see S.6-5 (Troubleshooting).

NOTE

After every signature listing the tube warm-up time is reset to 180 seconds regardless of time in the OFF LINE state.

6. MAINTENANCE**6-1. Cleaning****WARNING**

Do not use solvents for cleaning - they may be dangerous both for you and for the amplifier paint or plastics.

Do not open the amplifier. Cleaning of the amplifier outer surface can be done with a piece of soft cotton cloth lightly moistened with clean water.

6-2. Fuse Replacement

If it is necessary to replace the mains fuses, use only standard ones.

The Primary Mains Fuse(s) of the amplifier are located on the rear panel (Fig. 2-1). They are of the fast (quick blow) type, 1-1/4 x 1/4 inch Cartridge Fuses, Size "0". Use 20A for 100-120VAC operation. Use 16A for 200-240VAC operation (15A standard is also acceptable).

Besides the primary fuses, on the MAINS PCB (inside the amplifier) there are three small glass fuses (5x20mm European size): one 100mA 250VAC normal blow and two 2A 250VAC slow-blow. These fuses should not be replaced by the user. Should one of these fuses be blown, it may be indicative of a serious fault. A fault of this type will not occur under normal operating circumstances. Replacing these fuses involves special skills and is inherently dangerous. For these reasons, we recommend this work be carried out by a trained service technician.

6-3. Tube Replacement

A single 4CX1000A/8168 ceramic and metal tetrode is employed in the amplifier. Replacement is a complex and potentially dangerous procedure. For this reason, we recommend this work be carried out by a trained service technician. Check with your dealer before attempting to replace your tube.

6-4. The ACOM2100 Simplified Schematic Diagram

See Fig.6-1 ACOM2100 Simplified Schematic Diagram. The 4CX1000A/8168 ceramic and metal radial beam tetrode (V1) is grid-driven. It can dissipate up to 1000W when forced air cooled and is specifically designed for class AB1 RF linear amplifiers.

The input signal from the RF INPUT jack is passed through a broadband input matching circuit, which consists of components in the INPUT PCB and Rsw. This circuit tunes out the tube input capacitance. The swamping resistor Rsw is a termination load for this circuit and can dissipate up to 100W of RF drive power.

Cathode resistors labeled Rc create DC and RF negative feedback, thus stabilizing the gain and equalizing the frequency response. The varistor VSsg, in the screen grid circuit protects the tube and the screen grid voltage regulator in the event of an internal tube flashover.

The combination noted as Lp1-Rp1 in the plate circuit is a VHF/UHF parasitic suppressor. DC plate voltage is fed through chokes RFC1-RFC2 and the capacitor Cb3 blocks it from the output. The output circuit consists of LP1, LP2, LL, CP1-CP3, and CL1-CL3, which form a classic Pi-L network to suppress any harmonic frequency emissions. This tank is switched and tuned by S1A-S1C and the air variable capacitors CP1, 2 and CL1, 2. The output signal is fed through an additional VHF low-pass filter for frequencies above 55MHz (Lf1, Lf2 and Cf). Then it is passed through the vacuum antenna relay K1, wattmeter current transformer TA1, and a high-pass filter RFCasw-Casw for frequencies below 100kHz, to the antenna switch and the three outputs. The chokes RFC3 and RFCasw keep track of the antenna relay

contacts and together with Casw prevent the plate supply voltage from reaching the antenna. The RF choke RFCasw shunts the high voltage to ground should the DC blocking capacitor Cb3 fail. The resistor Rasw protects Casw from electro-static voltage build-up from the antenna.

The PLATE CAPACITIVE DIVIDER and RF WATTMETER are the main sources of information for the control circuit of the amplifier during the antenna impedance matching process. The control circuit is based on the 80C552 micro-controller from Philips.

All supply voltages are delivered from the MAINS&LOW VOLTAGE and HIGH VOLTAGE SUPPLY PCBs. The control grid, screen grid, and plate currents, plate cooling airflow temperature, reflected power, etc. are continuously monitored by the micro-controller. Many software-derived protections are based on this information.

* Detailed electrical schematic diagrams are available from ACOM or from your dealer on request.

6-5. Troubleshooting

See S.5-3 for the method of reading the auto-protection signatures. You can decode them using the information below.*

The signatures are structured in two lines, three groups by six symbols for every one event of auto-protection trip. The last event is numbered as 1A-1B pair of lines, and the oldest one is 7A-7B.

The meaning of the first group is as follows:

a) nA - the number of the trip;

b) Next three symbols mean the following:

PN0 - tests made during Power-On procedure, before HV is ON;

PN2 - tests made during Power-On procedure, after HV is ON and one second after step-start relay is closed;

SB0 - tests made in Stand-By, during the warm-up period or while entering Stand By (from Operate);

SB2 - tests made during Stand-By, after the warm-up period;

PR0 - tests made while entering Operate;

PR2 - tests made during Operate;

TR0 - antenna relay tests made while changing from Tx to Rx (during Operate)

TR2 - antenna relay tests made while changing from Rx to Tx (during Operate)

TR4 - antenna relay tests made during Tx (Operate mode)

TR6 - antenna relay tests made during Rx (Operate mode)

c) The last symbol of the first group designates the kind of the input parameter that caused the protection circuit to trip. The abbreviations in brackets below are the signal names/designations according to the CONTROL PCB electrical schematic diagram and signal type:

1 - peak forward power (p_{fwd}, analogue)

2 - reflected power (r_{fl}, analogue)

3 - input (drive) power (inp, analogue)

4 - peak anode alternate voltage (paav, analogue)

5 - screen grid current (g_{2c}, analogue)

- 6 - plate current (ipm, analogue)
- 7 - high voltage (hvm, analogue)
- 8 - exhaust air temperature (temp, analogue)
- 9 - drive power exists (*GRIDRF, logic)
- A - antenna power exists (*PANT, logic)
- B - output relay closed (ORC, logic)
- C - RF arc fault (ARCF, logic)
- D - control grid current too high (G1C, logic)
- E - +24VDC power supply error (PSE, logic)
- F - low airflow (LAIR, logic)

For instance, "1ATR4B" in the first group would mean that the last auto-protection (1A) tripped by the antenna relay tests made during the Tx - Operate mode (TR4), and the "output relay closed - ORC" signal was failing (B).

The next five groups of symbols carry information about the analogue and logic values as measured by the micro-controller at the moment of auto-protection trip.

* Additional information is available from ACOM or from your dealer on how to interpret these values. Using an Excel application available from ACOM or your dealer free of charge, and a PC, you can decode these signatures.

In case it is necessary to ship the amplifier please see S.7-3.

7. SPECIFICATIONS

7-1. Parameters

a) Frequency Coverage: All amateur bands 1.8-54MHz, extensions and/or changes on request.

b) Power Output: 1500W PEP or continuous carrier, no mode limit.

In continuous carrier modes (RTTY etc.) for transmissions longer than 5 minutes (up to several hours depending on ambient temperature), the external auxiliary fan must be installed.

c) Intermodulation Distortion: Better than 32dB below PEP rated output.

d) Hum and noise: Better than 40dB below rated output.

e) Harmonic Output Suppression:

1.8-21.5MHz - better than 50dB below rated output, 24-54MHz - better than 66dB below rated output.

f) Input and Output Impedances:

- Nominal value: 50 Ohm unbalanced, UHF (SO239A) type connectors;
- Input circuit: broadband, VSWR less than 1.3:1, 1.8-54MHz continuously (no tunings, no switching);
- Bypass path VSWR less than 1.1:1, 1.8-54MHz continuously;
- Output (antenna) impedance matching capability: VSWR up to 3:1 or higher.

g) RF Gain: 13.5dB typically, frequency response less than 1dB (50-85W drive power for rated output).

h) Primary Power: 100-264V (100, 110,120, 200, 210, 220, 230 & 240V nominal taps, +10% -15% tol.), 50-60Hz, single phase, 3500VA consumption at rated output.

i) Complies with CE safety and electromagnetic compatibility requirements as well as FCC-regulations.

j) Size & Weight (operating): W445mm x D375mm x H205mm, 29.3kg (17.5x14.8x8.1 inches, 64.6Lbs)

k) Operating environments:

- Temperature range: 0...+50 degs. Celsius;
- Humidity: up to 95% @ +35 degs. Celsius.
- Height: up to 3000m (10 000ft) above sea level without output deterioration.

7-2. Functions

a) Antenna Impedance Matching Process: plate-load True Resistance Indicator (TRI) aided.

b) Three antenna outputs selectable by a button on the front panel.

c) T/R System: QSK operation with quiet, built-in vacuum RF antenna relay.

d) Protections:

- Cover interlock for operator's safety;
- Inrush power-on current is limited;
- High voltage, control grid, screen grid, and plate currents;
- Exhaust air temperature;
- T/R sequencing;
- Antenna relay contacts, including RF power induced in antenna from another nearby transmitter;
- Antenna matching quality;
- Reflected power;
- RF arcs, including in antenna system;
- Overdrive.

e) Signatures of the amplifier internal status are stored in a nonvolatile memory for the 7 most recent auto protection trips.

- f) High brightness and contrast 5x7 dot character OLED display with bargraph for forward peak power and text messages to the operator.
- g) Measurement and constant monitoring of 12 most important amplifier parameters via OLED.
- h) Tube: a single 4CX1000A/8168 ceramic and metal radial beam tetrode with plate dissipation of 1000W (forced air cooled, grid-driven), specifically designed for class AB1 RF linear amplifiers.

7-3. Storage and Shipment

CAUTION

Should you need to transport the amplifier, use the original packing as described below.

First, switch off the amplifier. Pull the mains plug out of the wall outlet. Disconnect all cables from the rear panel of the amplifier (remove the ground connection the last). Then remove the mains power transformer, observing the requirements of the Transformer Installation leaflet but in reverse order. Finally, pack the amplifier and transformer in their original cartons.

- a) Storage environments: the amplifier can be kept packed in dry and ventilated unheated premises without chemically active substances (acids, alkalis etc.) in the following climatic environment:
 - Temperature range: -40 to +70 degs. Celsius;
 - Humidity: up to 75% @ +35 degs. Celsius.
- b) Shipping Size and Weight:
 - W390mm x D340mm x H340mm, 18.3kg (15.35x13.39x13.39 inches, 40.35 Lbs) – Transformer carton;
 - W600mm x D580mm x H275mm, 29.5kg. (23.62 x 22.83 x 10.83 inches, 71.21Lbs) – Amplifier carton.
- c) Shipping environments: all types of transportation, including aircraft baggage section up to 12 000 meters (40 000ft) above sea level.

END