

Bluetooth Speaker BS1130E / BS1130US

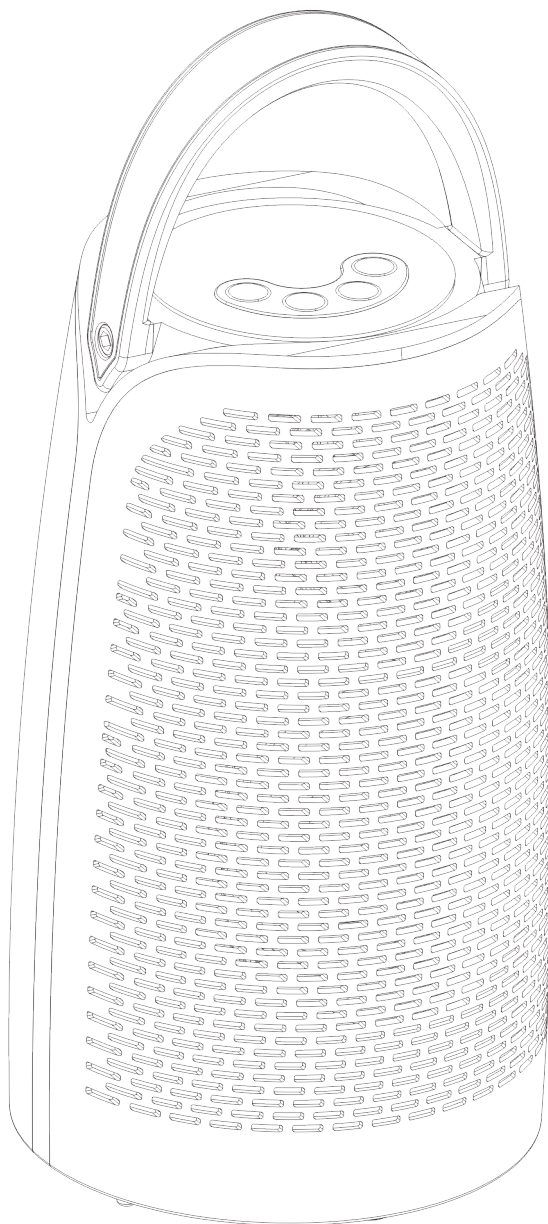

CE



Instruction Manual

A. INTRODUCTION

This Bluetooth wireless speaker system applies the latest BT 3.0 wireless technology platform that enables you to enjoy music, video everywhere you want.

B. FEATURES

1. Bluetooth 3.0 Platform
2. Operating distance up to 10 meters / 33 feet (open area)
3. Powered by 6 (six) C alkaline batteries (not included) or Power adapter
4. IPX 3 Water-proof feature
5. 3.5mm line in jack

C. PACKAGING

- 1 X Bluetooth speaker
- 1 X User manual
- 1 X Power adapter

D. COMPONENT IDENTIFICATION

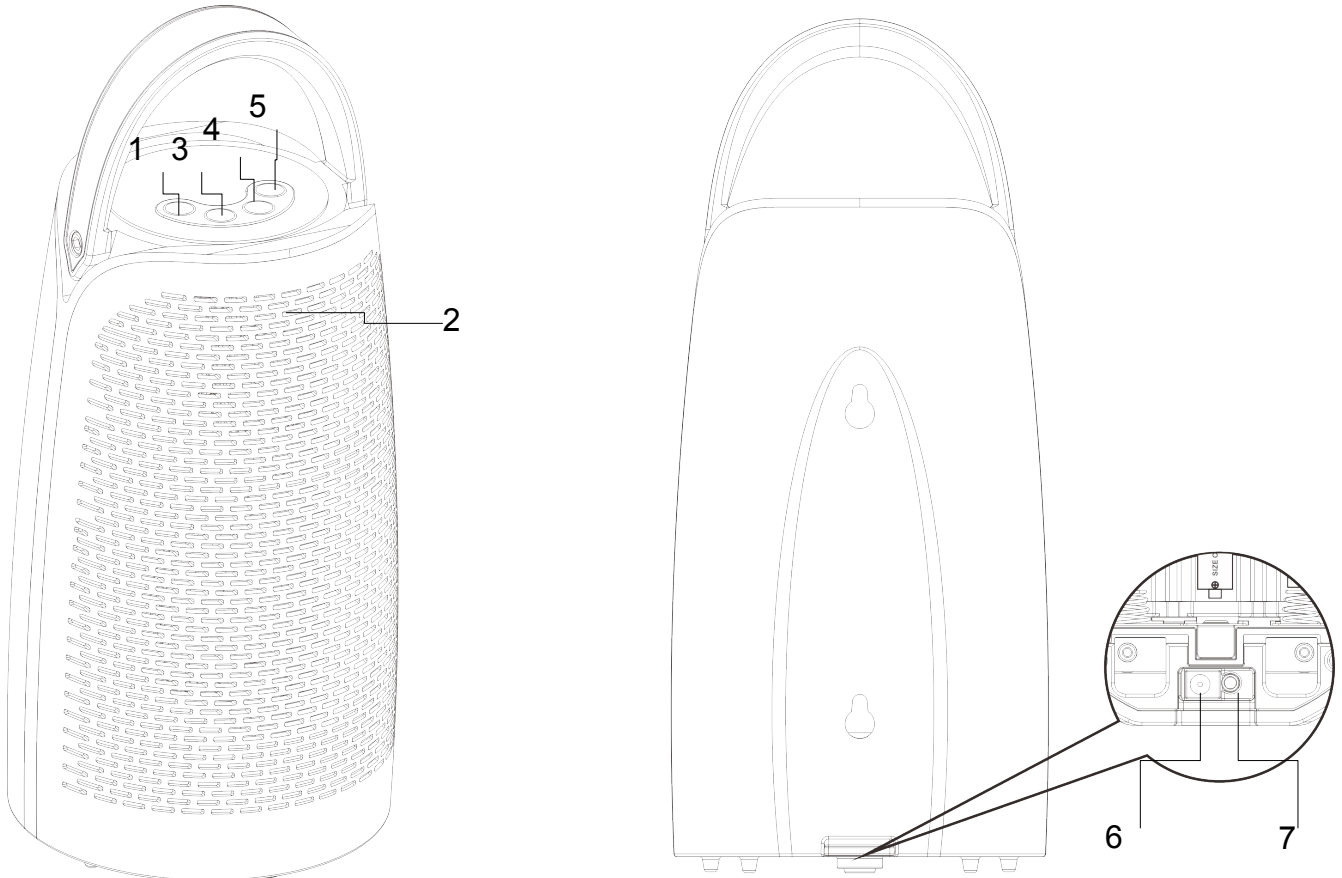

1. Power ON/OFF
2. Power LED Indicator
3. Pair
4. Volume -
5. Volume+
6. Power adapter jack
7. 3.5mm audio jack

E. PAIRING

1. Press the power button for 3 seconds to turn the speaker on, the Blue LED light will flash slowly.
2. Enable your Bluetooth device such as cell phones, tablets or other Bluetooth media, and make sure it is in searching mode.
3. The Bluetooth speaker will automatically search your blue tooth device and pair it up.
4. If no auto pairing connection is made, press the Pair button and hold for 5 seconds until the Blue LED flash quickly.
5. Select "**Alecto BSP-75**" in the list shown in the Bluetooth device.
6. Enter "0000" if password is required.
7. When Bluetooth connection is made, the Blue LED will solid.

8. Listen to your music.

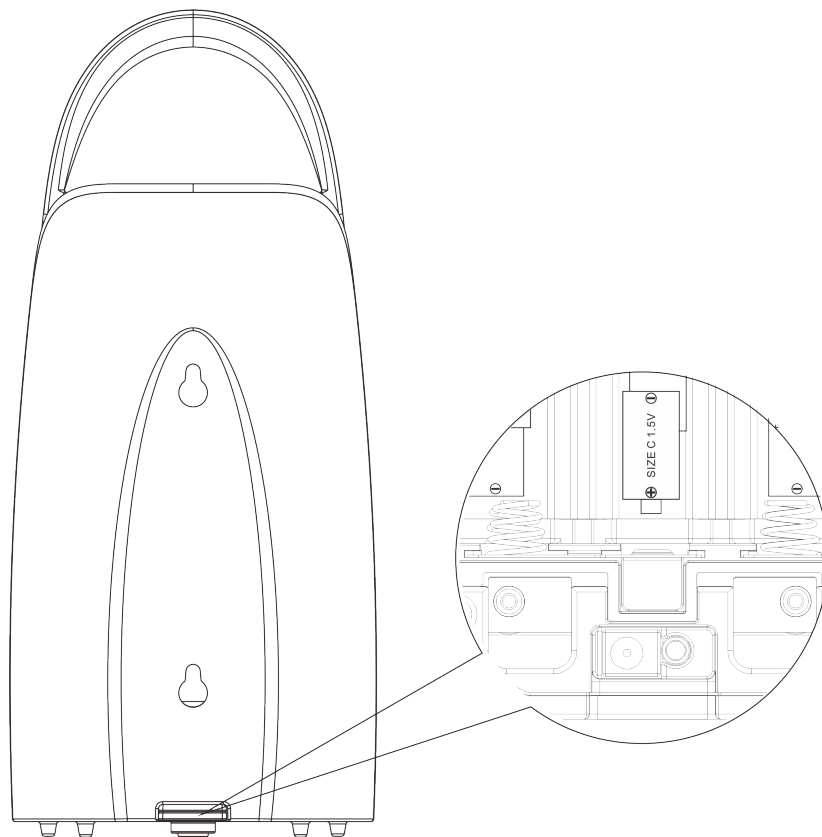

Battery Installation:

1. Turn the speaker over; on the bottom of the speaker you will see the battery door.
2. Open the battery door by pinching the two tabs and pulling towards you.
3. Install 6 (six) C size batteries following the battery markings inside the compartment.
4. Close the battery door until the door snaps shut.

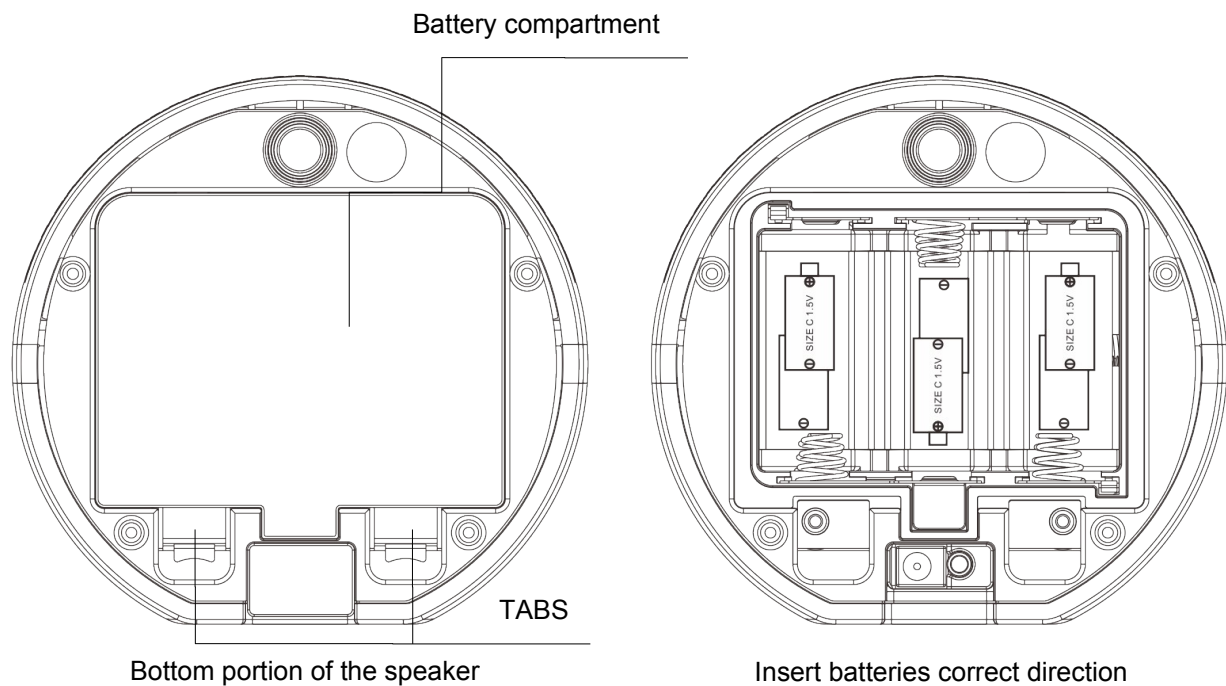

F. TECHNICAL SPECIFICATIONS

Carrier Frequency	: Bluetooth 3.0
Power Requirements	: By 6x C size alkaline batteries (not included) Or power adapter
Frequency Response	: 30Hz – 18KHz
Distortion	: <0.5%
S/N Ratio	: 65dB (typical)
Channel Separation	: 50dB (Typical)
Operation Distance	: Up to 10 meters / 33 feet (open area)
Output Power	: 5W (Max)

NOTES: This speaker is in compliance with the specified Bluetooth version. It does not guarantee compatibility of all functions on every Bluetooth enabled device. Please check with your mobile phone's user manual for compatibility and functionality.

G. TROUBLE SHOOTING

NO SOUND

- The speaker's battery charge is too low. Replace with the new batteries.
- Ensure the speaker is ON.
- Ensure Bluetooth device is ON.
- The volume of speaker is too low; adjust the volume to an appropriate level.
- Unable to connect with Bluetooth device, restart the pairing process.
- The speaker may be too far away from the Bluetooth device, move closer to it.

WARNING: Changes or modifications to this unit not expressly approved by the party responsible for compliance could void the user's authority to operate the equipment.

Note: Clean the speaker with soft, lint - free, dry cloth. Never use detergents or abrasive cleaners to clean.

H. FCC STATEMENT

This device complies with part 15 of the FCC rules. Operation is subject to the following two conditions:

- (1) This device may not cause harmful interference and
- (2) This device must accept any interference received, including interference that may cause undesired operation.

Important: Changes or modifications to this product not authorized and could void the FCC compliance and negate your authority to operate the product.

NOTE: This equipment has been tested and found to comply with the limits for a Class B digital device, pursuant to part 15 of the FCC Rules. These limits are designed to provide reasonable protection against harmful interference in a residential installation. This equipment generates, uses and can radiate radio frequency energy and, if not installed and used in accordance with the instructions, may cause harmful interference to radio communications. However, there is no guarantee that interference will not occur in a particular installation. If this equipment does cause harmful interference to radio or television reception, which can be determined by turning the equipment off and on, the user is encouraged to try to correct the interference by one or more of the following measures:

- Reorient or relocate the receiving antenna.
- Increase the separation between the equipment and receiver.
- Connect the equipment into an outlet on a circuit different from that to which the receiver is connected.
- Consult the dealer or an experienced radio/TV technician for help.



The Bluetooth word, mark and logo are owned by Bluetooth SIG, Inc. Any and all other trademarks and trade names are those of their respective owners.



If at any time in the future you should need to dispose of this product please note that: Waste electrical products should not be disposed of with household waste. Please recycle where facilities exist. Check with your Local Authority or retailer for recycling advice. (Waste Electrical and Electronic Equipment Directive).

