



*DC7000 Data Collection
Terminal*



Hardware Manual

FCC Warning:

Note: This equipment has been tested and found to comply with the limits for a Class A digital device, pursuant to Part 15 of the FCC rules. These limits are designed to provide reasonable protection against harmful interference when the equipment is operated in a commercial environment. This equipment generates, uses, and can radiate radio frequency energy and, if not installed and used in accordance with the instruction manual, may cause harmful interference to radio communications. Operation of this equipment in a residential area is likely to cause harmful interference in which case the user will be required to correct the interference at his or her own expense.

Caution: Changes or modifications not expressly approved by the party responsible for compliance could void the user's authority to operate the equipment.

FCC Compliance: (on hardware equipped with modem)

This equipment complies with Part 68 of FCC Rules and the requirements adopted by the ACTA. On the rear housing of this equipment is a label that contains, among other information, a product identifier in the format US:AAEQ##TXXXX. If requested this number must be provided to the telephone company.

This product uses USOC modular telephone jack: R-J11C

A plug and jack used to connect this equipment to the premises wiring and telephone network must comply with the applicable FCC Part 68 rules and requirements adopted by the ACTA. A compliant telephone cord and modular plug is provided with this product. It is designed to be connected to a compatible modular jack that is also compliant. See installation instructions for details.

The REN is used to determine the number of devices that may be connected to a telephone line. Excessive RENs on a telephone line may result in the devices not ringing in response to an incoming call. In most but not all areas, the sum of RENs should not exceed five (5.0). To be certain of the number of devices that may be connected to a line, as determined by the total RENs, contact the local telephone company. For products approved after July 23, 2001, the REN for this product is part of the product identifier that has the format US:AAEQ##TXXXX. The digits represented by ## are the REN without the decimal point (e.g., 03 is a REN of 0.3). For earlier products, the REN is separately shown on the label.

If this equipment, 4G3MM00B1011, causes harm to the telephone network, the telephone company will notify you in advance that temporary discontinuance of service may be required. But if advance notice isn't practical, the telephone company will notify the customer as soon as possible. Also, you will be advised of your right to file a complaint with the FCC if you believe it is necessary.

The telephone company may make changes in its facilities, equipment, operations or procedures that could affect the operation of the equipment. If this happens the telephone company will provide advance notice in order for you to make necessary modifications to maintain uninterrupted service.

If trouble is experienced with this equipment, 4G3MM00B1011, for repair or warranty information please contact Acroprint Time Recorder Co. at 800-334-7190. If the equipment is causing harm to the telephone network, the telephone company may request you disconnect the equipment until the problem is resolved.

This equipment is of a type that is not intended to be repaired. For service contact Acroprint Time Recorder Co. at 800-334-7190.

Connection to party line service is subject to state tariffs. Contact the state public utility commission, public service commission or corporation commission for information.

If you have specially wired alarm equipment connected to the telephone line, ensure the installation of this 4G3MM00B1011 does not disable your alarm equipment. If you have questions about what will disable alarm equipment, consult your telephone company or a qualified installer.

Canada

This Class A digital apparatus complies with Canadian ICES-003. Cet appareil numérique de la classe A est conforme a la norme NMB-003 Du Canada.

Lithium Battery Caution:

This circuit board on this terminal is populated with a lithium battery to protect data or programs stored in the Random Access Memory (RAM). Do not, under any circumstances, attempt to replace the lithium battery in the terminal. Failure to comply may invalidate your warranty. Battery replacement should be done by qualified personnel wearing the proper eye protection.

CAUTION: Danger of explosion if battery is incorrectly replaced. Replace only with the same or equivalent type recommended by the manufacturer. Discard used batteries according to the manufacturer's instruction.

Declaration Of Conformity According To EMC Directive 89/336/EEC

We declare under our sole responsibility that the DC7000 magnetic stripe and/or barcode reading and/or data recording equipment to which this declaration relates are in conformity with the following standards: EN55022:1987, EN50082-1, IEC 801-2, IEC 801-3, IEC 801-4, IEC 801-5. I, the undersigned, hereby declare that the equipment specified above conforms to the above directive and standards.

Raleigh, North Carolina USA

November xx, 2005

W. Glenn Robbins

All Rights Reserved. © COPYRIGHT **2005**

Acroprint Time Recorder Company

Table of Contents

1. Introduction.....	6
Basic Hardware and Variations	6
General Specifications	6
2. Setup.....	8
Site Requirements	8
Unpacking and Inspection	8
Mounting	9
Power Up	9
3. Operator Interface	10
Keypads	10
Card Readers.....	11
Proximity Badges.....	12
4. Ports and Connections	12
Ethernet Port.....	12
Wireless WiFi Connection.....	13
RS-232 Serial Port	13
RS-232 Cabling	14
Local Area Network: RS-485 Serial Port	15
RS-485 Serial Cables	16
Modem Port	17
Modem Cables	18
Wand Port.....	19
Wand and Y-Cable	20
Parallel Port	21
Parallel Cable.....	22
5. Companion Products	23
Readers	23
Power Supplies	23
External Relay Box, External Buzzer	24
Cables.....	25
Cables, Converter, Badge Racks.....	26
6. Appendix	27
Acropoint Data Collection Terminal Setup Instructions.....	27
Electrical Connections.....	30

1. Introduction

Basic hardware and variations

The electronic hardware is a new, versatile platform designed for use with various applications. This manual describes, in detail, the electronic hardware aspects of the terminal you have purchased. The details concerning terminal firmware and host software are addressed in the manual, which comes with the software.

All terminals are equipped with:

- 1) 2 row x 20 character per row blue backlit display
- 2) 16-key full travel keypad
- 3) RS-232 serial port
- 4) wand port for optional barcode wand
- 5) two control lines for external relay control (door access and bell ringer are typical applications)
- 6) 25-pin parallel port

The terminal is offered with different hardware options as listed below:

Comm2:	RS485, MODEM, Ethernet, or wireless Ethernet
Barcode:	Internal Visible or Infrared Barcode Badge Reader
Proximity:	Proximity badge reader: 125kHz RFID or HID
Fingerprint:	Fingerprint Verification
Magnetic Stripe:	A Track 2 ABA magnetic badge reader is standard, but can be optioned out.

Note: The part number of your unit can be found on the serial number label on the back of the terminal.

General specifications

- A. Enclosure: 8.7 in. (23 cm) wide x 6.1 in. (16 cm) tall x 2.3 in. (6 cm) deep. “Clamshell” construction of 0.125 in. (3 mm) thick Polycarbonate/ABS injection molded flame retardant plastic. Includes reversible mounting bracket and access door which protects I/O ports.
- B. Multilayer main logic board with internal ground and power planes.
- C. eZ80 Microprocessor.
- D. Most common memory configuration is 1 Meg program Flash, 512K of Data Storage and 512K of RAM.
- E. Real Time Clock with Lithium battery backup.

-
- F. Display: Backlit, Blue Background, 2 lines with 20 characters on each line.
 - G. Keypad: Full travel keys with elastomeric contact pad, 4 rows x 4 columns.
 - H. Serial Port: RS-232 using 6 position (4 contact) RJ-11 modular connection.
 - I. Serial Port: RS-485 (Local Area Network) using RJ-11 modular connection.
 - J. Parallel port: 25-pin DB connection.
 - K. Internal 56K Modem, licensed for use over public telephone lines.
 - L. Internal Multi-Frequency Piezo Electric Buzzer.
 - M. Internal Barcode Reader: Visible or Infrared Barcode reading through the slot.
 - N. Control lines: Two pins of the 6-pin circular DIN connector can be used with external relay box to control devices such as door locks and bells.
 - O. External Barcode port: 6-pin DIN connection for external Barcode Wand or Barcode Gun.
 - P. Power: Wall mount transformer, 9 Volts AC 1 amp standard or 3 amp for units with FIU, Modem or Wireless communications.
 - Q. Fingerprint: Bioscript MVLite Fingerprint Reader
 - R. Proximity: 125kHz RFID Proximity Reader or HID Proximity Reader
 - S. Ethernet: 10/100 baseT Ethernet Interface
 - T. Wireless 10 baseT 802.11b wireless communications
 - U. Flash program storage
 - V. State of the Art FRAM Data Storage

2. Setup

Site requirements

The terminal can be installed in any normal office or controlled factory environment. However, do not use the terminal under the following conditions:

- extremely high or low temperature
[operating temperature range: 0° to 50° C (32° to 122° F)]
[storage temperature range: -20° to 60° C (-4° to 140° F)]
- extremely high or low humidity
[operating humidity range : 10 to 90% RH non-condensing]
- areas of high dust concentration
- areas with chemical fume concentration
- areas with extreme vibration or when placed on an unstable or unlevelled surface

Unpacking and Inspection

Open the shipping carton and carefully remove the contents. Inspect the terminal and accessories for damage. Report damage or shortages to the company from which the unit was purchased. Complete the registration card with all of the information.

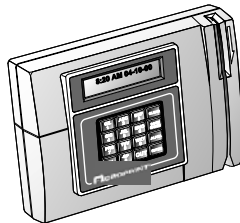

(1) Terminal



(4) Mounting Screws

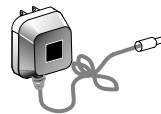

(1) Power Supply



(1) Manual

Mounting

Unscrew the access door. With the door off, the main unit can be slid upward and removed from the mounting bracket. The bracket can be used for wall mounting, or it can be reversed to tilt the unit on a desktop.

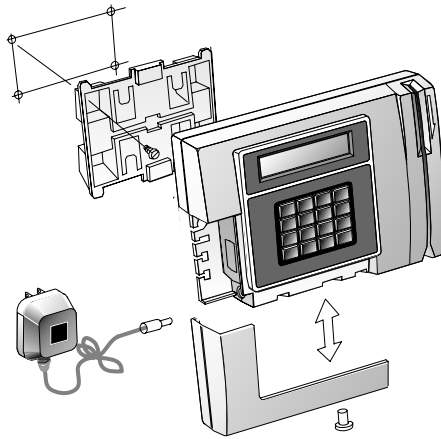

Power up

Plug in the power cord coming from the wall mount transformer into the terminal. To reattach the access door and secure the unit to the reversible bracket, screw on the door.

NOTE: Other connections are made in the same fashion. Notice the channels in the bracket available for cable routing. Also, the bracket has through-holes for further securing of cables using ties.

3. Operator Interface

Keypads

The standard terminal keypad has 16 keys for entering alphabetical and numeric data as illustrated below.



Standard Alpha-Numeric Keypad

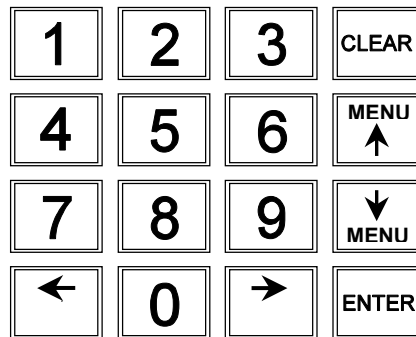

Optional Numeric Keypad

Card Readers

The DC7000 is available with (3) types of card readers.

- a) Magnetic stripe card reader. The magnetic stripe on the card should be on the right side when the card is swiped as shown below.

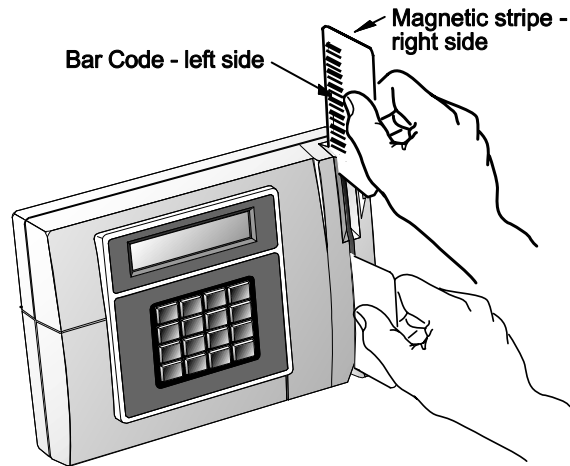

- b) Internal Barcode Reader. Infrared or visible barcode readers are available. The card is swiped through in the same fashion, but the barcode should be on the left side of the card when swiped.



NOTE: For through-the-slot reading, the barcode should be located on card as shown. Available barcode symbologies are 3 of 9 (Code 39) and 2 of 5 Interleaved.