

# 2.4G Deluxe Multimedia Keyboard

## *USER'S GUIDE*

Ver.:1.00

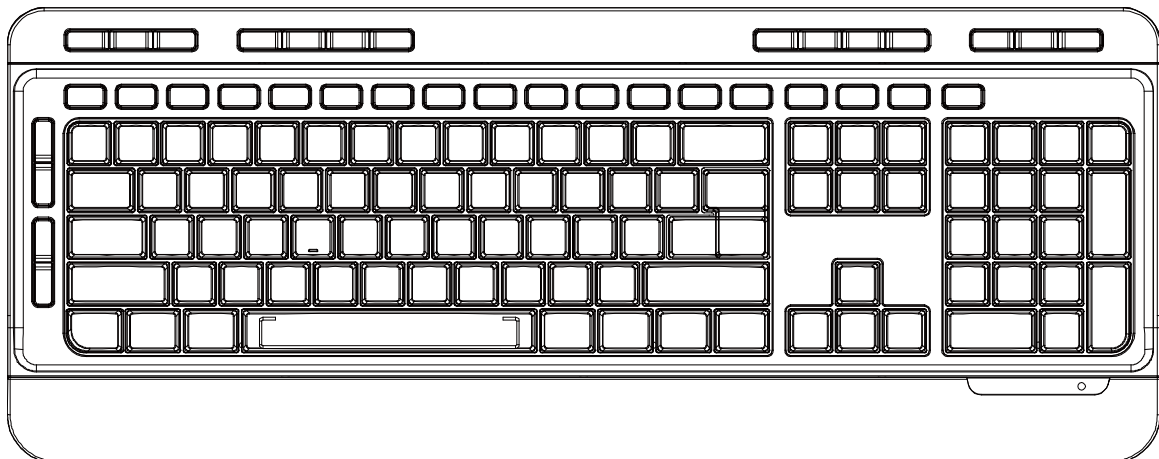

CAUTION: To use this product properly, please read the user's guide before installation

## **Federal Communication Commission Interference Statement**

This equipment has been tested and found to comply with the limits for a Class B digital device, pursuant to Part 15 of the FCC Rules. These limits are designed to provide reasonable protection against harmful interference in a residential installation. This equipment generates, uses and can radiate radio frequency energy and, if not installed and used in accordance with the instructions, may cause harmful interference to radio communications. However, there is no guarantee that interference will not occur in a particular installation. If this equipment does cause harmful interference to radio or television reception, which can be determined by turning the equipment off and on, the user is encouraged to try to correct the interference by one of the following measures:

- Reorient or relocate the receiving antenna.
- Increase the separation between the equipment and receiver.
- Connect the equipment into an outlet on a circuit different from that to which the receiver is connected.
- Consult the dealer or an experienced radio/TV technician for help.

FCC Caution: Any changes or modifications not expressly approved by the party responsible for compliance could void the user's authority to operate this equipment.

This device complies with Part 15 of the FCC Rules. Operation is subject to the following two conditions: (1) This device may not cause harmful interference, and (2) this device must accept any interference received, including interference that may cause undesired operation.

# Functional Introduction





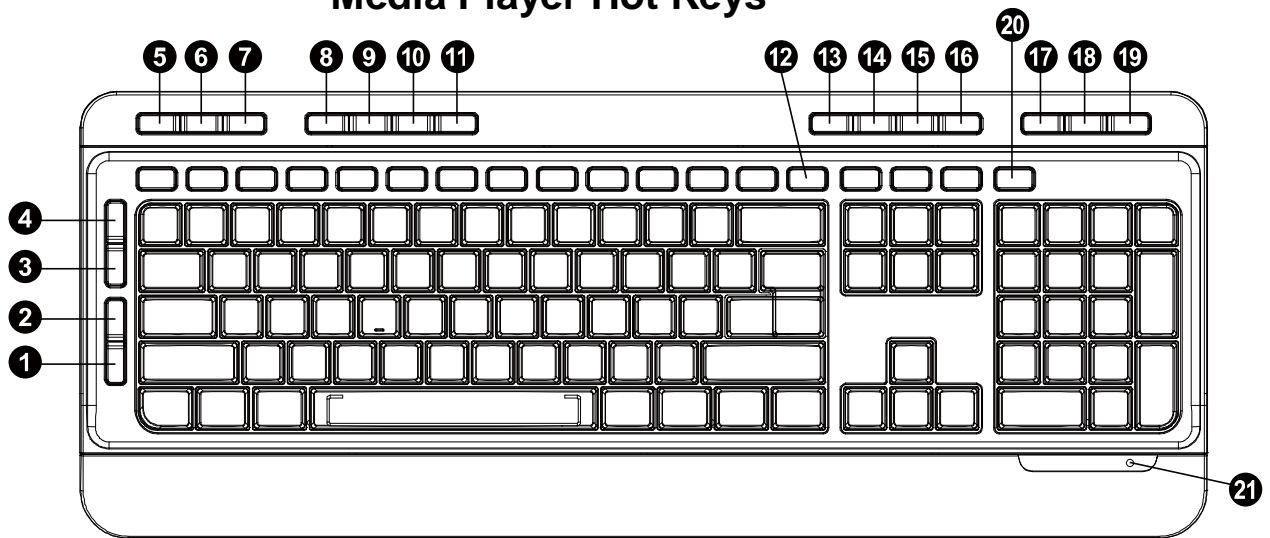



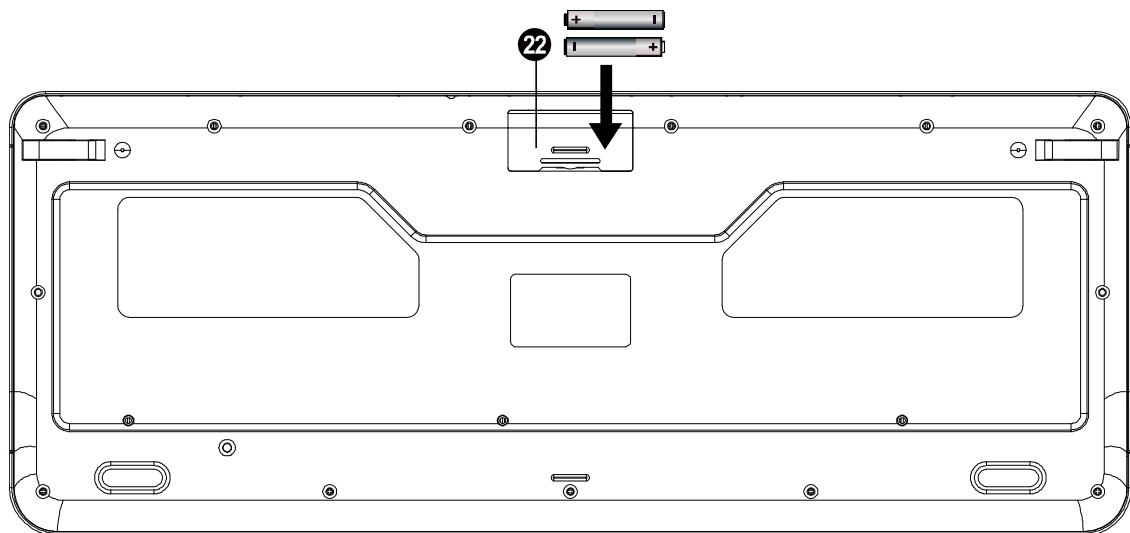









## Keyboard Buttons

### Media Player Hot Keys



### AAA battery X2



<b>Media Player Hot Keys</b>			
1.		Outlook(E-mail)→Default	Start the default e-mail program
2		Homepage(www/e)	Start the default Web browser and loads the home Web page
3.		Forward	Forward to the next page on Internet browser
4.		Back	Back to the last page on Internet browser
5.		Search	Open the Internet Explorer Search panel
6.		Refresh	Reload the current page
7.		My Favorites	Start my favorites
8.		Play/Pause	Switch between playing and pausing media
9.		Previous	Switch to the previous media track
10.		Next	Switch to the next media track
11.		Stop(Media)	Stop playing the media in the media player
12.		My Computer	My Computer
13.		Volume down (Voice-)	Decrease the computer's sound volume.
14.		Volume up (Voice+)	Increase the computer's sound volume.
15		Mute	Mute (turns off) the computer's sound
16		Media Player on	Open the media player
17		Sleep	let PC into sleep (stand by) mode
18		Weak up	let PC (had into stand by) to weak up
19		Power	let PC to shut off
20	<b>Connect Button</b>		
21	LED Indicator		Low Battery & Pairing Indicator
22	Battery Cover		

### **Setup the Connection between the Receiver and the Keyboard.**

1. Insert the batteries into the Keyboard, then follow the steps below.
2. Plug the Nano receiver into the USB port of your computer.

3. If the keyboard is not working, please put it into pairing mode.
4. Pairing: Re-plug the receiver into the USB port of your computer, then press the “**ESC**” and “**Connect**” button on the keyboard. If the keyboard does not work after 10 seconds, pair them again. (The receiver has auto pairing function).

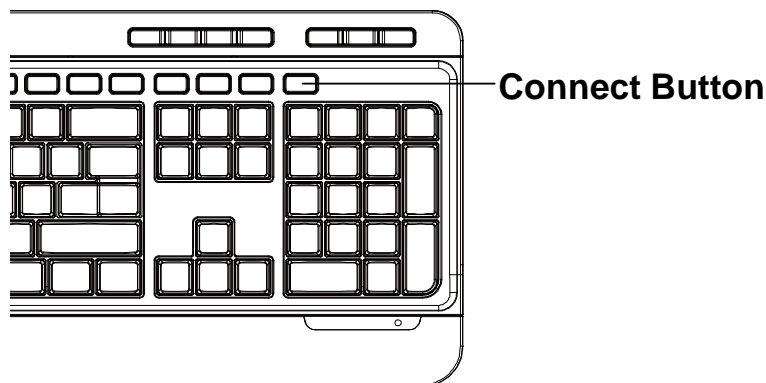

5. The LED indicator on keyboard flashes steadily when it is in pairing mode and stops blinking when it is successfully paired with the receiver.
6. When the batteries' power of the keyboard is low, the Low Power indicator will start to blink.

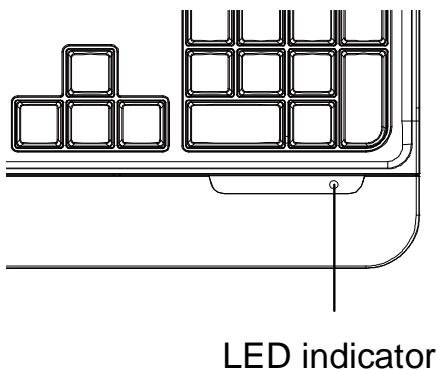

**\*Keyboard Indicator**

**Red LED is on for 10 sec.**  
Power ON

**Red LED Blinks for 10 sec.**  
Low Battery Warning

**Red LED Blinking**  
Pairing (LED OFF when paired or failed after 10 sec.)