

5800-OD Wireless Outdoor Motion Sensor – Installation Instructions

Review

Copy 5-02-08

GENERAL INFORMATION

The Honeywell 5800-OD Wireless Outdoor Motion Sensor (referred to as the 5800-OD) combines the convenience of wireless technology with a full featured outdoor PIR motion sensor. The major features are highlighted below:

- Immunity to bright light disturbances from headlights, sunlight, and other bright light sources.
- Discriminates both large and small animals to reduce false alarms.
- Battery saving circuit allows for a 5 or 120 second period of inactivity before being reactivated.
- Very low current draw.
- Selectable detector range and angle.
- Tamper detection.

Range	Adjustable up to 12m (40ft)
Pattern	90° pattern consisting of 13 zones. This pattern can be adjusted in 15° increments from center up to 45°.
Sensitivity	2.0° C at 0.6m/s (3.6° F at 2.0ft/s)
Detection Speed	0.3 - 1.5m/s (1 - 5ft/s)
Operating Voltage	6 VDC (uses 4 lithium 1.5VDC AA cells)
Current	3mA max (during walk test) 10uA (standby)
Battery Saving Timer	Adjustable 120sec or 5sec
Alarm Period	~ 2.5 seconds
LED Indicator	Enabled during a walk test. Disabled for normal operation.
Weatherproof	IP54 compliance
Operating Temperature	- 20 to + 50 ° C (- 4 to +122° F)
Humidity	95% Max
Accessories (included)	Pole mounting kit, screw kit, detection masking strips.

SPECIFICATIONS

Detection Method	Passive Infrared
Initial Warm Up	~ 2 minutes
Mounting Height	0.8 - 1.2m (2.7 - 4ft) wall or pole

INSTALLATION (refer to the Component Identification Diagram on page 5)

1 Select the Mounting Position

- Orient the detector so that intrusion passes across the detection field, not into the sensor.

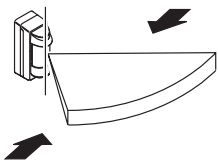

- Avoid strong sunlight into the sensor's field.
- Avoid moving or swaying trees and bushes.

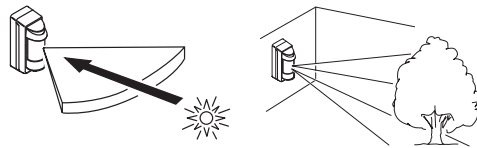

- Allow 110mm (4.4") above the sensor to enable opening the cover.
- Choose an installation height of 0.8m to 1.2m (2.7 to 4ft).

- Ensure the sensor can be mounted on a perpendicular wall or pole that would make its detection pattern parallel to the ground.

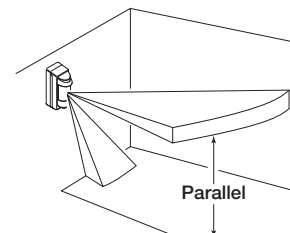

2 Prepare the Sensor for Mounting

- Loosen the **Captive Lock Screw** and remove the **Cover**.

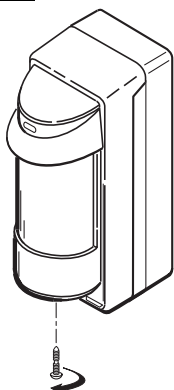

- Remove the four (4) screws fastening the **Detector** to the **Back Box**.

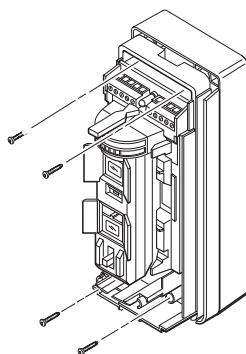

- Remove **Detector** from the **Back Box**.

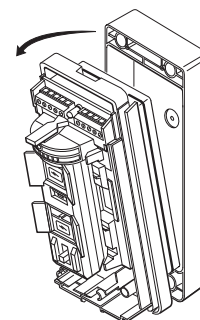

3 Install / Replace the Battery

IMPORTANT:

- Use only lithium batteries.
- Use four (4) lithium 1.5VDC AA cells. (Energizer L91 or equivalent.)
- Observe polarity.
- Mark the date of replacement on the batteries.

- If necessary, loosen the **Captive Lock Screw** and lift **Cover** off. Then, remove 4 screws that secure the **Detector** to the **Back Box**.
- Observe the proper polarity and replace the batteries. **Ensure positive side of battery is pointing away from the springs.**
- For reference, mark the date of replacement on the batteries.

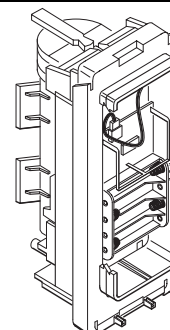

5800-OD Wireless Outdoor Motion Sensor – Installation Instructions

4 Mount the Sensor

WALL MOUNTING

1. Install the **Back Box** on the wall with the two T4 x 20 mounting screws.

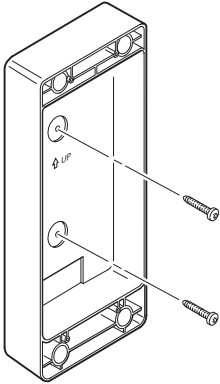

2. Insert the batteries (see **Install/Replace the Battery**), then secure the **Detector** to the **Back Box**.

3. Fasten with four (4) screws.

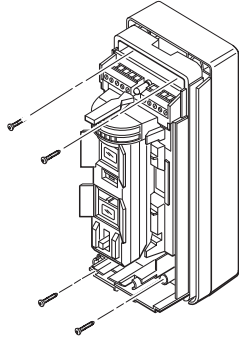

4. Perform **Settings & Adjustments**.

5. Perform a **Walk Test**.

6. Secure the **Cover** with the **Captive Lock Screw**.

POLE MOUNTING

1. Use a pole with an outside diameter of 43-48mm (1.69-1.89").

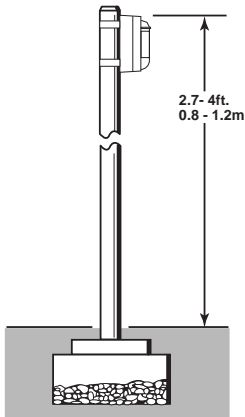

2. Attach the **Brackets** to the **Back Box** with two M4 x 30 screws.

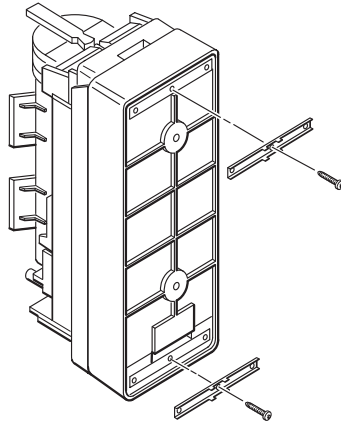

3. Using the **Pole Brackets** and four M4 x 30 screws, fasten the **Back Box** to the pole.

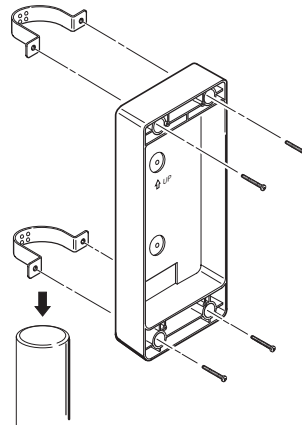

4. Insert the batteries (see **Install/Replace the Battery**), then mount the **Detector** on the **Back Box** and fasten with four (4) screws.

5. Perform **Settings & Adjustments**.

6. Perform a **Walk Test**.

7. Secure the **Cover** with the **Captive Lock Screw**.

5 Perform Settings & Adjustments

SET THE DETECTION LENGTH

Note: The length of the lower detection area determines the detection length.

The upper detection area stays parallel to the ground at all times. The lower detection area can be adjusted as shown below by the switch position.

Detection length is therefore limited by the length of the lower detection area since both upper and lower areas have to be blocked at the same time to activate the sensor.

IMPORTANT:

- This sensor detects temperature differences between the moving object and the background temperature in the detection area to produce a valid detection.
- If the object does not move, the sensor will not detect it.
- If there is traffic near the detection area, adjust the detection area length 1.5 to 2.0m (5 to 7ft) back from traffic.

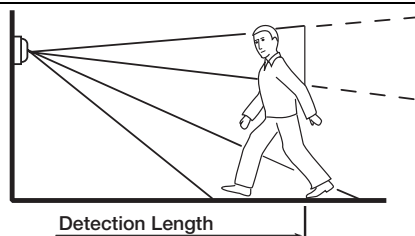

UPPER and LOWER beams are blocked, detection is made.

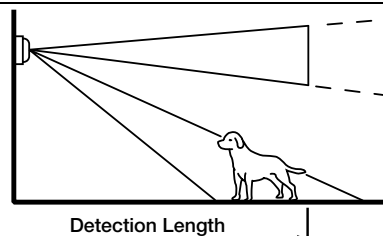

Only the LOWER beam is blocked, detection is not made.

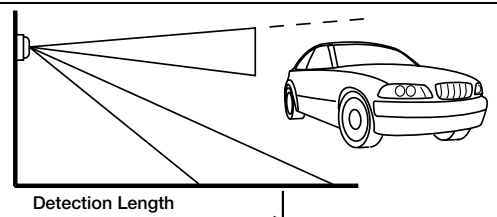

Only the UPPER beam is blocked, detection is not made.

5800-OD Wireless Outdoor Motion Sensor – Installation Instructions

Press and slide the Detection Length Adjustment Switch to the desired position.

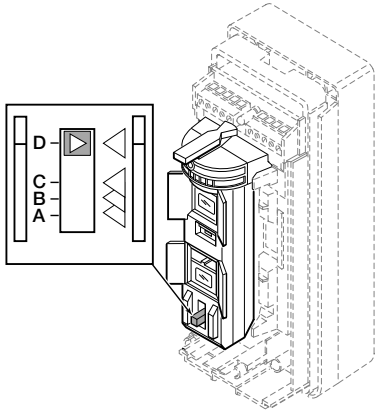

POSITION	MAX DETECTION LENGTH	
	STANDARD	ENVIRONMENTAL *
D	2.0m (6.7ft)	1.5 - 2.5m (5 - 8ft)
C	5.0m (16.7ft)	4 - 5.5m (13 - 18ft)
B	8.0m (26.7ft)	6 - 10m (20 - 33.3ft)
A	12.0m (40.0ft)	10 - 15m (33.3 - 50ft)

* Detection length may vary due to environmental conditions.
Detection height = 1m (3.3ft)

SET THE DETECTION AREA ANGLE

1. The detection area angle is 90° with 7 fingers as shown.

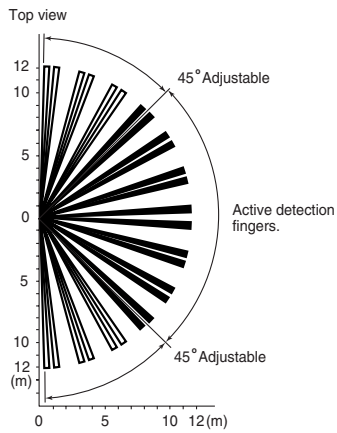
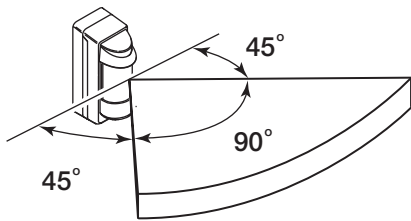

2. Hold the sensor and turn it to the desired direction. Each click represents 15° of change.

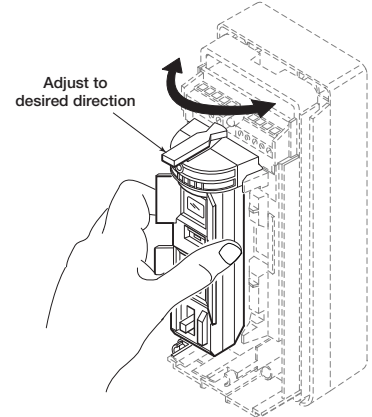

IF NECESSARY, CONFIGURE DETECTION MASKING

1. Spread the Cover and gently press on the Lens to remove the Lens Holder.

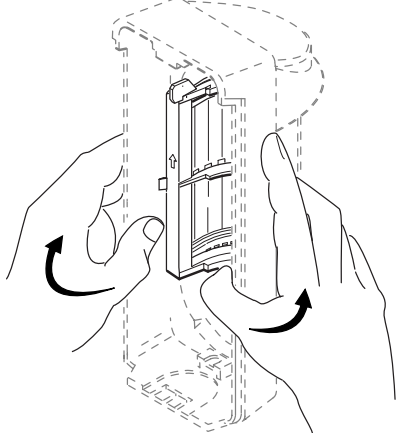

2. Separate the Lens from the Cover.

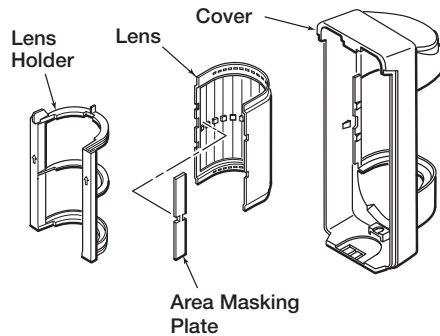

4. Then apply the adhesive Masking Strip(s), as necessary, inside the lens to cover the desired segments.

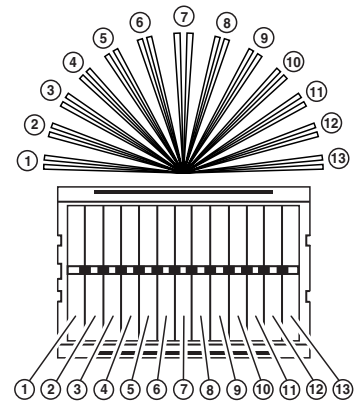

3. Identify the segments on the Lens to be masked.

5. Replace the Lens by aligning the 4 cutouts on the lens to the 4 projections on the cover. Snap in place with the Lens Holder.

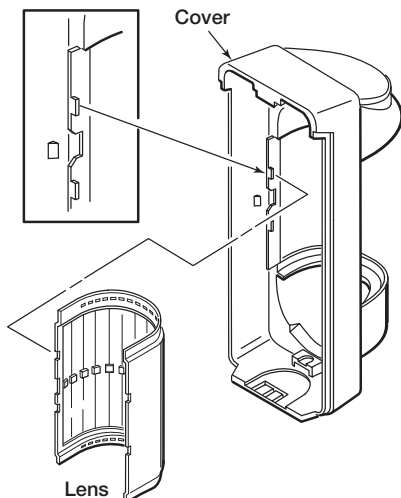

6. Ensure the Lens Holder is held by the left and right cover prongs and the two tabs are engaged.

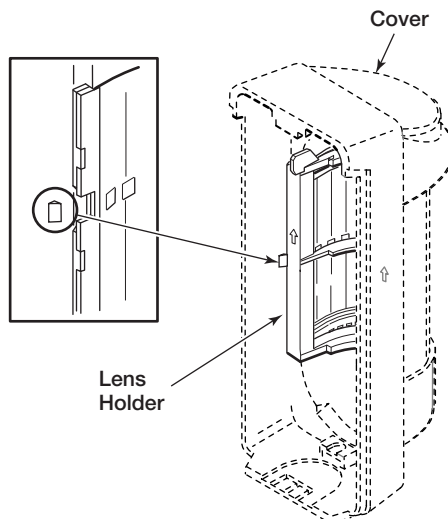

5800-OD Wireless Outdoor Motion Sensor – Installation Instructions

SET THE SENSITIVITY

1. Set the **Sensitivity Select Switch** to the desired sensitivity.

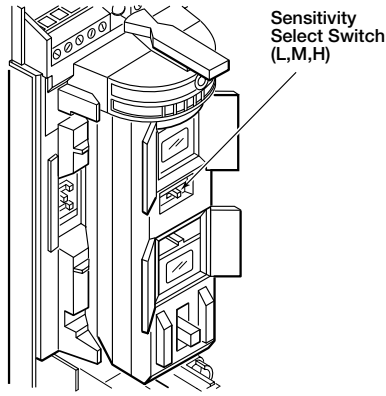

Notes:

- When greater sensitivity is desired, select "H".
- When conditions are poor select "L".

SET THE DIP SWITCHES

1. Set **switch 2** for the desired Battery Saving Timer period.

Note: The alarm output activations are limited by the timer selection (5 or 120 seconds). Even if there are continuous alarm events, the alarm output operates only once in the selected timer period. This can be 5 or 120 seconds.

120s – Default Setting

5s – Used when frequent alarm transmission is required. Battery life will be shortened when using this setting.

2. Set **switch 3** for the desired Pulse Count (selectable for 2 or 4).

Pulse Count of 2 = detection can be made with as little as two steps.

Pulse Count of 4 = detection can be made with as little as four steps.

3. Set **switch 1** to enable the Walk Test, see the instructions below.

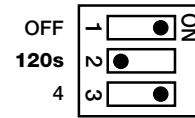

ON 1. Walk Test

5s 2. Battery Saving Timer

2 3. Pulse Count

6 Perform a Walk Test

NOTE: With the Walk Test switch set to ON the LED will light when the detector is tripped, and the alarm is generated instantly.

1. Set the walk test switch (DIP switch 1) to ON. Replace the cover.
2. Perform a walk test through the detection area, and verify satisfactory results.
3. Allow the detection area to remain static and check for false or unwanted detections.
4. If necessary, adjust the detection area (see Perform Settings & Adjustments).
5. Repeat the walk test through the detection area, and verify satisfactory results.
6. Set the walk test switch to OFF, and secure the **Cover** with the **Captive Lock Screw**.

Notes:

- If normal car or people traffic pass close to the detection area, adjust the detection area 1.5 to 2.0m (5 to 7ft) shorter to reduce false detections. This also allows for changes due to environmental thermal conditions.

- If the detection length is adjusted to position "A" [12m (40ft)], the detection area may increase when there is a big temperature difference between the moving object and the background.

- If this causes a problem, adjust the detection length to position "B". Then walk test to verify satisfactory results.

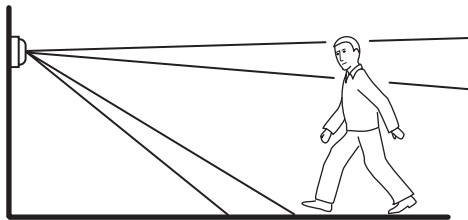
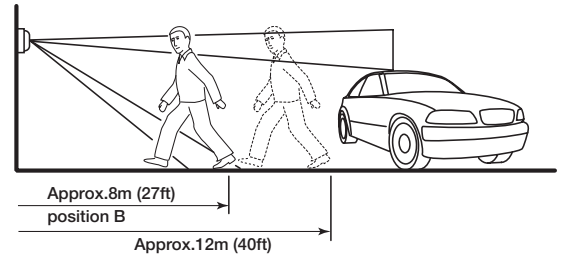

WALK TEST

- This sensor has a multi-level detection pattern (from side view). A heat source beyond the detection area may cause the detector to issue a false alarm by reflecting off the ground. Examples include puddles, wet surfaces, very smooth asphalt or concrete surfaces.
- If this causes a problem, adjust the detection length to position "B". Then perform a walk test to verify satisfactory results.

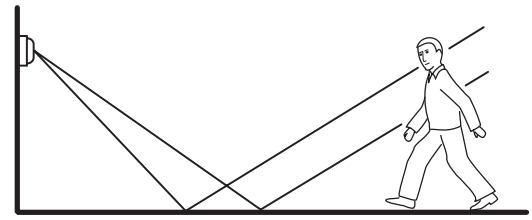

7 Program the Control Panel

Prior to use in the system, you must "enroll" the transmitter's serial number in the control panel. Refer to the control panel's instructions for further details. During programming, the transmitter shall be treated as **RF supervised**. (Mandatory for UL installations.)

TROUBLESHOOTING

SYMPTOM	CAUSE	REMEDY
No detection, when walking through the detection area.	Batteries are incorrectly installed or dead.	Check for correct battery installation, or replace dead batteries.
	Wiring is faulty or loose.	Check all connectors and wiring.
	Water in unit.	Check for cracks in the housing that would allow water infiltration. Replace unit.
	Transmitter or PIR sensor is faulty.	Replace unit.
No detection occasionally, or poor detection.	Sensitivity is set too low.	Try a higher sensitivity setting.
	Detection area is not set correctly.	Perform a Settings & Adjustments procedure.
Low battery fault indicated on system keypad display.	Batteries are very low or dead.	Replace batteries.

5800-OD Wireless Outdoor Motion Sensor – Installation Instructions

TROUBLESHOOTING

SYMPTOM	CAUSE	REMEDY
Alarms when no one is walking through the detection area.	Sensor is not perpendicular to ground.	Remount and align sensor so the detection area is parallel to the ground.
	Sensor is detecting moving trees, bushes, or a strong source of light.	Check for moving trees, or bushes or a strong light source. Perform a Settings & Adjustments procedure.
	Lower detection area is too long.	Set Detection Length to a shorter range.
	A heat source in the area may be causing an abrupt temperature change.	Move or remove the heat source. Mask the area pointing to the source of heat, or shorten the Detection Length.

COMPONENT IDENTIFICATION

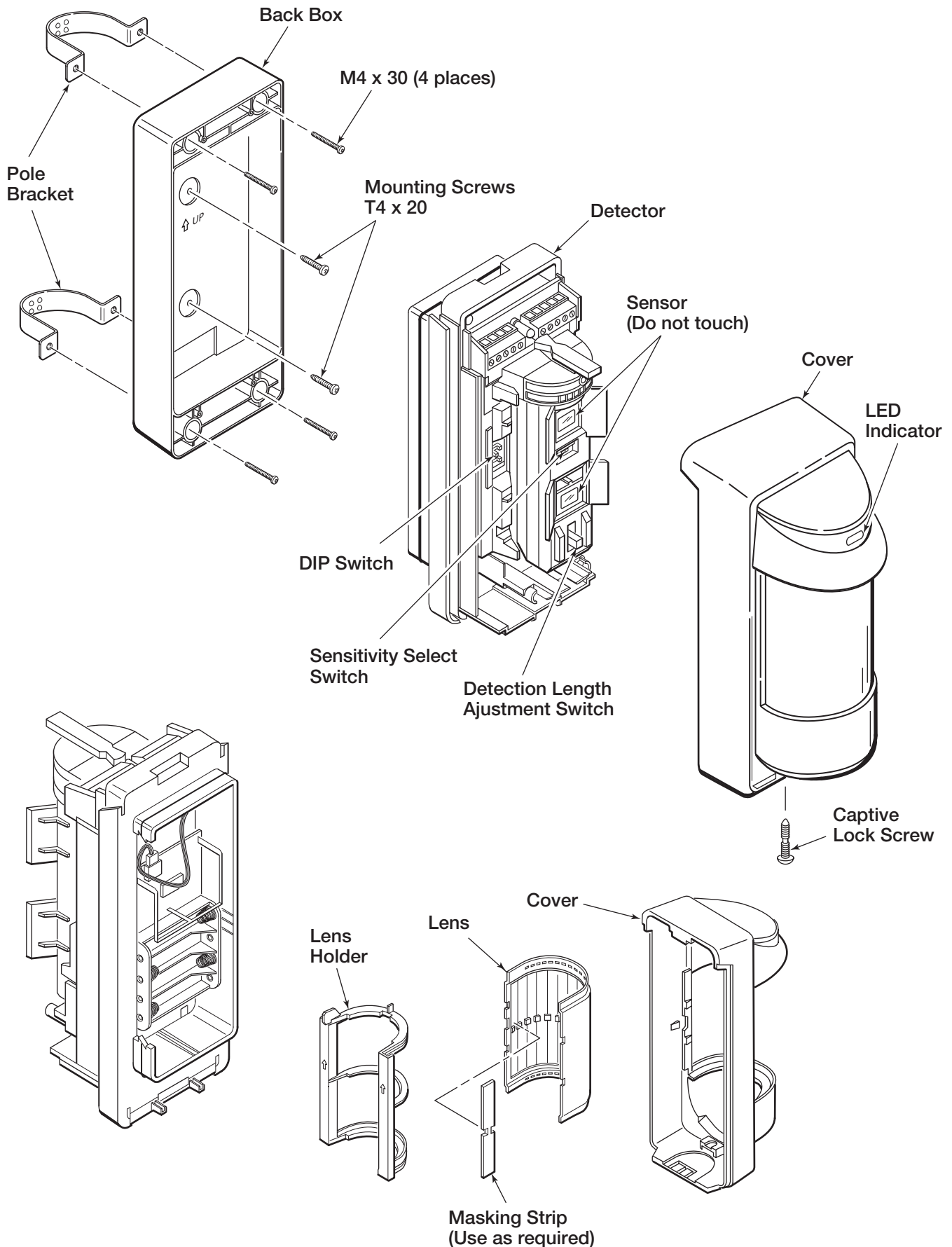

5800-OD Wireless Outdoor Motion Sensor – Installation Instructions

USER NOTIFICATION

The user shall not make any changes or modifications to the equipment unless authorized by the installation Instructions or User's Manual. Unauthorized changes or modifications could void the user's authority to operate the equipment.

FCC & IC

LIMITATIONS OF THE PIR MOTION DETECTOR

While the detector is a highly reliable intrusion detection device, it does not offer guaranteed protection against burglary. Any Intrusion Detection device is subject to compromise or failure to warn for a variety of reasons:

- Passive Infrared Motion Detectors can detect intrusion only within the designed ranges as diagrammed in this installation manual.
- Passive Infrared Motion Detectors do not provide volumetric area protection. They do create multiple beams of protection, and intrusion can be detected only in unobstructed areas covered by those beams.
- Passive Infrared Detectors cannot detect motion or intrusion that takes place behind walls, ceilings, floors, closed doors, glass partitions, glass doors, or windows.
- Mechanical tampering, masking, painting, or spraying of any material on the lenses, windows or any part of the optical system can reduce the detection ability of the Passive Infrared Motion Detector.
- Passive Infrared Detectors sense changes in temperature; however, as the ambient temperature of the protected area approaches the temperature range of 90° to 105°F (32° to 40°C), the detection performance can decrease.
- This Passive Infrared Detector will not operate without the appropriate battery installed, or if the battery is weak or improperly connected (i.e., reversed polarity).
- Passive Infrared Detectors, like other electrical devices, are subject to component failure. Even though this equipment is designed to last as long as 10 years, the electronic components in it could fail at any time.

We have cited some of the most common reasons that a Passive Infrared Motion Detector can fail to catch intrusion. However, this does not imply that these are the only reasons, and therefore it is recommended that weekly testing of this type of unit, in conjunction with weekly testing of the entire alarm system, be performed to ensure that the detectors are working properly.

Installing an alarm system may make the owner eligible for a lower insurance rate, but an alarm system is not a substitute for insurance. Homeowners, property owners and renters should continue to act prudently in protecting themselves and continue to insure their lives and property.

We continue to develop new and improved protection devices. Users of alarm systems owe it to themselves and their loved ones to learn about these developments.

FCC / IC STATEMENT

This device complies with Part 15 of the FCC Rules, and RSS210 of IC.

Operation is subject to the following two conditions: (1) This device may not cause harmful interference. (2) This device must accept any interference received, including interference that may cause undesired operation.

WARRANTY

For the latest warranty information, please go to:
<http://www.security.honeywell.com/hsc/resources/wa/>

To obtain applicable EU compliance Declaration of Conformities for this product, please refer to our Website,
<http://www.security.honeywell.com/hsce/international/index.html>.

For any additional information regarding the compliance of this product to any EU specific requirements, please contact:

Quality Assurance Department,
Honeywell Security & Custom Electronics,
Newhouse Industrial Estate
Motherwell,
Lanarkshire ML1 5SB,
Scotland, United Kingdom.
Tel: +44(0)1698 738200
Email: UK64Sales@Honeywell.

© 2008 Honeywell International Inc. Honeywell is a registered trademark of Honeywell International Inc. All other trademarks are the properties of their respective owners. All rights reserved.

Please contact your local authorized Honeywell representative for product warranty information.

