



5800RP-ADT RF Repeater Module Installation Instructions

INTRODUCTION

The 5800RP-ADT RF Repeater Module, with RF receiver and transmitter extends the range of 5800 series RF devices by 200 feet (nominal).

- The 5800RP-ADT receives alarm, status, and control messages from 5800 series devices, and forwards these messages to control panel connected receivers such as the 5881EN, 6160RF, 6150RF, and LYNX controls. The control then responds accordingly (arm/disarm the system, initiate an alarm, etc.).
- The 5800RP-ADT also transmits its own status including tamper, AC loss and RF jam detect via a built-in serial number assigned to a control panel zone(s). Status is sent whenever a change occurs or as part of a supervisory check-in message sent approximately once an hour.
- The 5800RP-ADT contains a rechargeable battery that provides up to 6 hours of standby operation after primary power is lost.
- The 5800RP-ADT features a Spatial Diversity system that virtually eliminates the possibility of "Nulls" and "Dead Spots" within the coverage area.

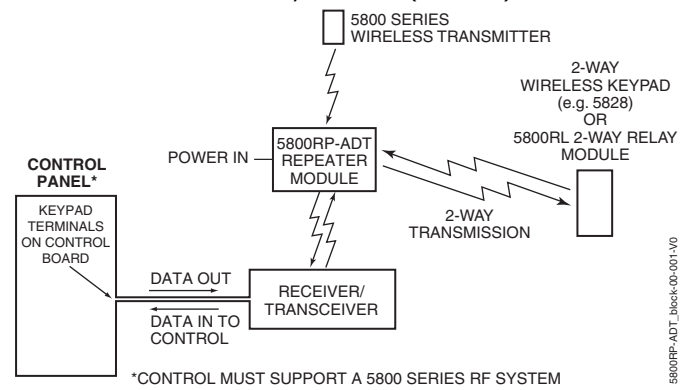

Figure 1.
Wireless System Overview using 5800RP-ADT Repeater Module

INSTALLING THE 5800RP-ADT MODULE

Mount the 5800RP-ADT remotely in its own housing following the steps below, and avoid mounting the module with its antennas touching a metal surface.

Check for RF Interference: Before mounting permanently, use the red RF Interference LED to check for strong local radio frequency interference at the intended mounting location. If this LED is continuously lit, the 5800RP-ADT module should be relocated.

Removing the Cover: Remove the 5800RP-ADT's cover by inserting and twisting a screwdriver blade. See Figure 2.

Note: Removing the cover places the 5800RP-ADT in the **Go/No Go Test** mode. This decreases its range during installation to insure an adequate margin during normal operation.

Mounting the Module

- For concealed wiring, route power wires through the rectangular opening at the rear of the base before mounting. See Figure 3.
- For surface wiring entry, a thin breakaway area is provided along the base's right edge.
- Mount the module in the selected location. For greatest security, use all four mounting holes (two key slot holes and two round holes) in the plastic base.
- Install each antenna in the respective right-hand terminal of the two terminal blocks at the upper edge of the 5800RP's circuit board, and tighten the screws to secure them.
- Affix the Summary of Connections label to the outside back cover. See Figure 2.
- If applicable, set the Site ID by referring to the *Setting the Site ID* section below.

Connecting the Power Supply

The 5800RP-ADT is powered from an AC external power source connected to terminals 1 and 2. See Figure 2.

Power source ratings are as follows:

Type	Rating
Class 2 AC Transformer	9VAC, 15VA (Honeywell PN 300-07753)

- Connect the transformer to the 5800RP-ADT's terminals. Refer to Figure 3. These terminals are not polarized. The leads from AC transformer may be connected to either terminal. Do not connect to a receptacle controlled by a switch.

NOTE: Use of power sources with higher or lower voltages may result in damage or failure to operate properly. Non-Honeywell power supplies may have connectors installed. Remove the connectors prior to attempting to connect power supply to 5800RP-ADT.

Connecting the Battery

- Plug the battery cable into the battery connector on the 5800RP-ADT PCB. See Figure 3.
- CHARGING NOTE:** The battery must be allowed to charge for at least 48 hours to reach full capacity.
- Replace the cover on the 5800RP-ADT, being careful not to pinch the battery wires between the cover and case or any PCB components.

Replacing the Battery

- See removing the cover above.
- Unplug the battery cable from the 5800RP-ADT PCB.
- Remove the retaining clips and pull up old battery.
- Affix one side of the fastener strip to the battery compartment, if required and affix the other side of the fastener strip to the battery so they are aligned.
- Firmly press the battery's fastener strip to the fastener strip in the compartment and secure using the two retaining clips.
- Connect the battery. See Step 7 above.

SETTING THE SITE ID

Some wireless devices (e.g., 5828) use a programmed house ID to help avoid communication conflicts with nearby installations. The 5800RP-ADT automatically passes all house ID information to the appropriate receiver.

Certain wireless devices use a "Site ID" instead of a House ID. The Site ID is a factory-assigned, unique serial number built into each TS BASE console, and must be entered into each device that uses it. The Site ID provides many more combinations than a House ID, and therefore is less likely to have conflicts with nearby installations.

When using the 5800RP-ADT with wireless devices that use a Site ID, follow the steps below to enter the Site ID in the 5800RP-ADT. This procedure assumes that all such devices have been successfully set-up and tested with the TS BASE, although they may not yet be mounted in their final locations.

- Put the TS (Total Security) control in test mode by pressing "123451" on the keypad. Keypad displays "test in progress".
- Remove the 5800RP-ADT's cover. See "Removing the Cover" section above.
- Temporarily disconnect the power supply and battery from the 5800RP-ADT.
- Place DIP switch 1 in the ON position.
- Reconnect the power supply to the 5800RP-ADT. Observe that the red LED on the 5800RP turns on and remains on. This indicates that the 5800RP-ADT is ready to set the Site ID.
- Continue pushing the * button on the keypad for intervals of approximately 2 seconds until the red LED on the 5800RP-ADT turns off.
- When the red LED turns off, this indicates the Site ID has been saved in the 5800RP-ADT and will no longer accept the Site ID. If the LED does not turn off, repeat the previous step until it does.
- Place DIP switch 1 in the OFF position.
- Replace the cover on the 5800RP-ADT.
- If needed locate the other wireless devices in their final locations.
- Test all wireless devices.

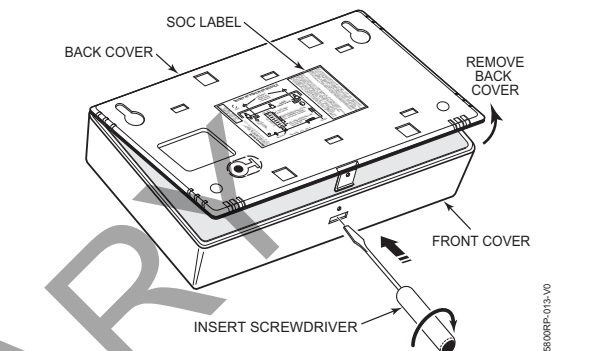

Figure 2: Removing the Cover

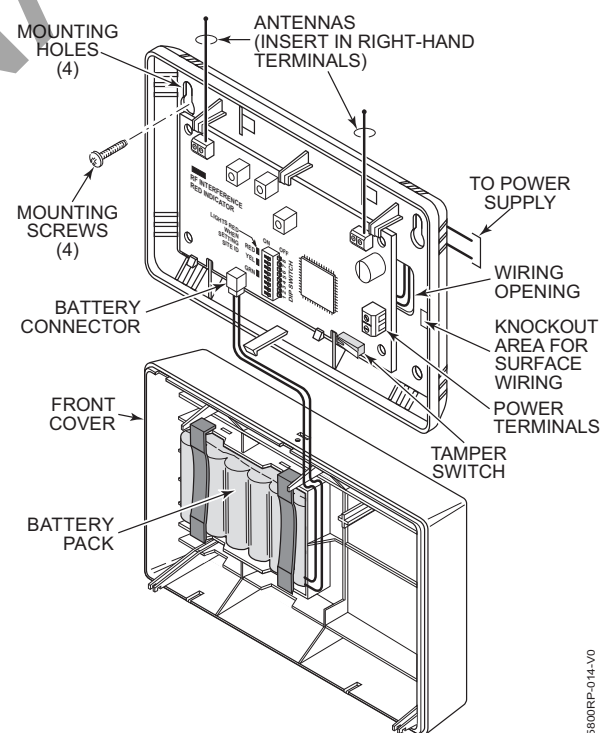

Figure 3: Mounting the Module

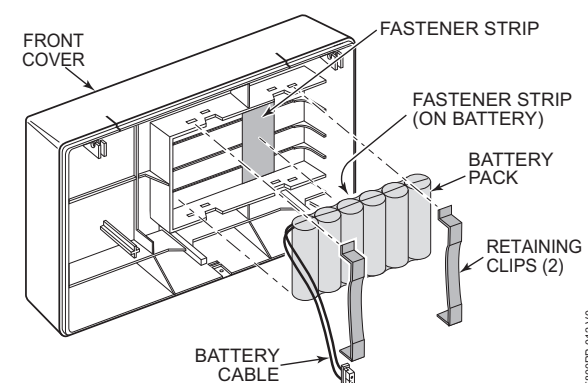

Figure 4: Replacing the battery

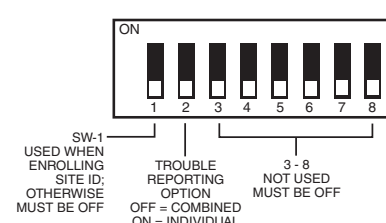

Figure 5: 5800RP-ADT DIP Switch

LED FUNCTIONS

LED	Activates Upon
Green	Normally on (lighted) when power (AC or battery) is present. Flickering indicates RF is being processed.
Yellow	Normally off. Blinks to indicate that an RF message is being sent by the 5800RP.
Red	Normally off. Turns on (lighted) when setting Site ID. See the <i>Setting the Site ID</i> section for details.
Red RF Interference	Lights when RF activity is present.

PROGRAMMING NOTES

Programming for Combined Trouble Reporting

(Check-in, low battery[†], AC loss, and RF jam messages all report on one zone.)

- Set DIP switch 2 to **OFF** (keep switch 2 in the OFF position when enrolling is complete).
- Assign the 5800RP-ADT to a zone for sending check-in, low battery[†], AC loss, and RF jam messages, and enroll its serial number. When prompted, toggle the tamper switch to enroll the serial number. The yellow LED should blink on when messages are sent. Program the zone as follows:

Zone Type	Input Type	Loop
8 (24-hour aux)	3 (supervised RF)	1

- AC loss and RF jam conditions report as "low battery" status, which is also displayed on the control's keypads. This prevents either condition from causing an alarm when the control is armed.
- Tamper conditions report according to the zone type response for which the trouble zone is programmed (ex. ZT 8, 24-hr Aux).
- The 5800RP-ADT will not repeat a message that has already been repeated.

Programming for Individual Trouble Reporting

(Check-in/low battery[†], AC loss, tamper, and RF jam messages report on 4 individual zones.)

- Assign 4 zones and enroll the module's two serial numbers as follows:
 - Assign the first serial number to a zone for sending low battery[†] and supervision check-in messages.
 - Assign the second serial number to 3 zones for sending tamper, AC loss, and RF jam messages.
 When prompted, toggle the tamper switch to enroll the serial numbers.

Program the zones as follows:

First Serial Number: located on PCB label.			
Set DIP switch 2 to OFF , then enroll as follows:			
Zone	Zone Type	Input Type	Loop
Low Battery/ Check-in Zone	8 (24-hour aux)	3 - RF (supervised RF)	1
Second Serial Number: equals first serial number plus 1. (example: if the last 2 digits of Serial #1 are 39, Serial #2 will end with 40.)			
Set DIP switch 2 to ON , then enroll as follows: (keep switch 2 in the ON position when enrolling is complete)			
Zone	Zone Type	Input Type	Loop
Tamper Zone	5 (trouble by day / alarm by night)	4 - UR (unsupervised RF)	1
AC Loss Zone	8 (24-hour aux)	4 - UR	2
RF Jam Zone	8 (24-hour aux)	4 - UR	3

For easy identification of these messages, program alpha descriptors at the control for each zone, using words such as "REPEATER LOW BATTERY, REPEATER AC LOSS, etc.

[†] If an actual low battery condition is reported, it takes up to 24 hours after AC power is restored for the low battery restore message to be sent.

Note for Control Panel's Current Drain Calculation: When choosing the backup battery capacity for systems using a 5800RP-ADT, use the connected keypad's maximum alarm (sounding on) current rating, not the keypad's standby current rating, when calculating the control panel's total current drain. This is necessary because AC loss at the 5800RP-ADT causes the keypad to beep.

SPECIFICATIONS

Dimensions: 7-3/8" W x 4-3/8" (10-7/8" w/antennas) H x 2-1/8" D
188mm W x 112mm H (277mm w/antennas) x 54mm D

Input Voltage: 12VDC or 9VAC, 15VA (from separate power supply such as Honeywell 300-07753).

Current: 80mA

Battery Pack: rechargeable, part number 300-03865

Range: 200ft (60m) nominal indoors from wireless devices (the actual range to be determined with the security system in the TEST mode).

TO THE INSTALLER

Regular maintenance and inspection (at least annually) by the installer and frequent testing by the user are vital to continuous satisfactory operation of any alarm system. The installer should assume the responsibility of developing and offering a regular maintenance program to the user, as well as acquainting the user with the proper operation and limitations of the alarm system and its component parts. Recommendations must be included for a specific program of frequent testing (at least weekly) to insure the system's operation at all times.

FEDERAL COMMUNICATIONS COMMISSION & INDUSTRY CANADA STATEMENTS

The user shall not make any changes or modifications to the equipment unless authorized by the Installation Instructions or User's Manual. Unauthorized changes or modifications could void the user's authority to operate the equipment.

CLASS B DIGITAL DEVICE STATEMENT

This equipment has been tested to FCC requirements and has been found acceptable for use. The FCC requires the following statement for your information:

This equipment generates and uses radio frequency energy and if not installed and used properly, that is, in strict accordance with the manufacturer's instructions, may cause interference to radio and television reception. It has been type tested and found to comply with the limits for a Class B computing device in accordance with the specifications in Part 15 of FCC Rules, which are designed to provide reasonable protection against such interference in a residential installation. However, there is no guarantee that interference will not occur in a particular installation. If this equipment does cause interference to radio or television reception, which can be determined by turning the equipment off and on, the user is encouraged to try to correct the interference by one or more of the following measures:

- If using an indoor antenna, have a quality outdoor antenna installed.
- Reorient the receiving antenna until interference is reduced or eliminated.
- Move the radio or television receiver away from the receiver/control.
- Move the antenna leads away from any wire runs to the receiver/control.
- Plug the receiver/control into a different outlet so that it and the radio or television receiver are on different branch circuits.
- Consult the dealer or an experienced radio/TV technician for help.

Federal Communications Commission (FCC) Part 15

This device complies with Part 15 of the FCC Rules and RSS-210 of Industry Canada. Operation is subject to the following two conditions: (1) This device may not cause harmful interference, and (2) this device must accept any interference received, including interference that may cause undesired operation.

Cet appareil est conforme à la partie 15 des règles de la FCC & de RSS-210 des Industries Canada. Son fonctionnement est soumis aux conditions suivantes: (1) Cet appareil ne doit pas causer d'interférences nuisibles. (2) Cet appareil doit accepter toute interférence reçue y compris les interférences causant une réception indésirable.

INDUSTRY CANADA CLASS B STATEMENT

This Class B digital apparatus complies with Canadian ICES-003.

Cet Appareil numérique de la classe B est conforme à la norme NMB-003 du Canada.

SUPPORT & WARRANTY

For the latest documentation and online support information, please go to:
<https://mywebtech.honeywell.com/>

For the latest warranty information, please go to:
www.honeywell.com/security/hsc/resources/wa.



MyWebTech



Warranty

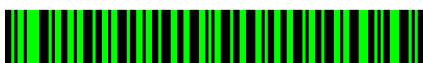

800-20965-1 9/15 Rev. B



ADT Security Services
1501 Yamato Rd
Boca Raton, FL 33431
Copyright © 2013