

## INSTALLATION AND SETUP GUIDE

### GENERAL INFORMATION

The ADEMCO 5809EN Rate-of-Rise Heat Detector is a wireless device used with ADEMCO alarms systems that support 5800 series devices.

The 5809EN combines both rate-of-rise and fixed temperature sensors. Fires typically cause a rapid rise in temperature in the surrounding area. The 5809EN's rate-of-rise thermostat senses the rise in temperature and signals an alarm if the rise is 15°F (8°C) or more per minute. A built-in fixed temperature sensor will also signal an alarm if the ambient temperature rises above 135°F (57°C).

**NOTE:** If the fixed temperature sensor activates, the 5809EN must be replaced.

The 5809EN is powered by a 3-volt lithium battery. If the battery voltage gets too low, the 5809EN sends a low battery signal to the control panel.

The 5809EN also features a tamper switch, which causes a trouble signal to be sent to the control if the unit is removed from the mounting base.

A built-in activation button, located on the detector assembly, is used when programming the unit's serial number at the control and when testing the unit.

### Installing the Battery

Important Notes:

- Use 3-volt lithium battery:
  - Duracell DL 123A or
  - Panasonic/Sanyo/Varta CR123A.
- Observe polarity.
- When replacing the battery, wait at least 30 seconds after removing the old battery, before installing the new one.

Remove the detector assembly from its mounting base and install a 3-volt lithium battery as shown below.

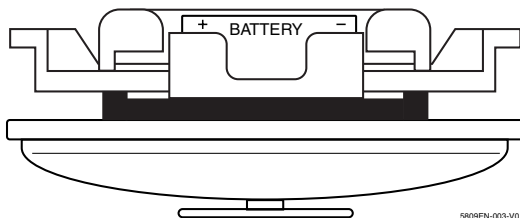

### PROGRAMMING THE UNIT

The transmitter's serial number must be enrolled in the control panel before usage in the system. Refer to the Installation and Setup Guide for which this device is to be used for programming procedures for enrolling transmitter serial numbers. Before programming do the following:

1. Remove the unit assembly from its mounting base by twisting counter-clockwise and lifting.
2. Install the battery (if not already installed). Observe polarity!

3. Enter the control's programming mode and follow the control's programming instructions. When programming this transmitter at the control, note the following:

- Input Type = 3 (Supervised RF)
- Loop number = 1

Transmit from the detector when prompted (momentarily press the activation button in shown below). You can also manually enter the detector's serial number.

4. Test the detector after enrolling into the system. Refer to the Testing section.

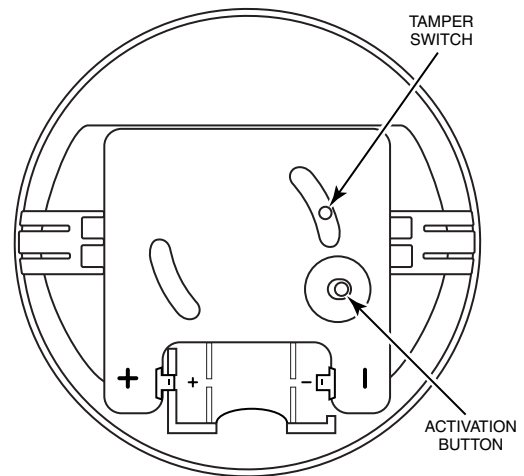

### MOUNTING THE DETECTOR

You can mount the 5809EN on a wall or ceiling within the protection area:

- **Wall Mounting:** Mount the detector 4" - 6" from the ceiling.
- **Ceiling Mounting:** Mount the detector at least 4" from any wall. Make sure the normal ceiling temperature will not exceed 100°F.
- Refer to NFPA Standard 72 for detector spacing and other requirements. Maximum spacing for UL installations is 50'x50'.
- Avoid mounting the detector near heat generating devices (e.g. ovens, heat vents, furnaces, boilers).

**IMPORTANT:** Heat detectors should be used for property protection. Reliance should not be placed solely on heat detectors for life safety. When life safety is involved, smoke detectors **MUST** also be used. Detectors must not be painted.

### Wireless Transmission Path Test

A good RF transmission path must be established from the proposed mounting location before permanently installing the detector. To determine that there is good signal reception from the proposed location, perform the test procedure described in TESTING THE DETECTOR section. Once a good RF transmission path is confirmed, mount the detector as follows:

1. Surface mount the unit's plastic base to a wall or ceiling, or mount the plastic base to either a 4" junction box or 3-1/4 octagon box.

NOTE: The anti-twist mounting hole is for use when installing the device directly to wall-board to prevent the base from being twisted off when servicing the device.

2. Install the detector assembly to the base and secure by twisting clockwise. Make sure to align the tamper posts in the base with the tamper index relief's in the detector assembly.

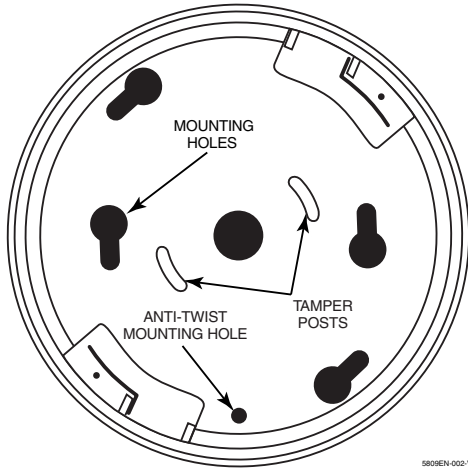

## TESTING THE DETECTOR

The test procedure should be performed to determine a good RF transmission path and again after installation is completed.

CAUTION: The rate-of-rise heat sensor is intended for one-time use. Prolonged heat during testing can damage the unit. If used carefully following the instructions described below, the heat from a portable hair dryer can be used to test the unit. If the round disk on top of the detector detaches, the detector must be replaced.

Activate the control panel's test mode.

Use either method (a) or (b) to activate the detector:

(A) Press and release the activation button on the PC board assembly.

OR

(B) Holding a portable hair dryer about 12 to 18 inches away from the detector, turn the dryer on and aim the warm air at the side of the detector.

CAUTION: Aiming the dryer directly at the round disk on the detector can damage the detector requiring the unit to be replaced.

The system's keypads should beep and the detectors ID should be displayed.

Exit the control's test mode.

## MAINTAINING PROPER OPERATION

To maintain the detector in proper working condition, it is important that you observe the following:

Replace the battery when the system indicates that the 5809EN has reported a low battery condition.

Units should never be relocated without the advice or assistance of the alarm service company.

## SPECIFICATIONS

Power: 3V lithium battery

(Duracell DL123A, Panasonic CR123A, Sanyo CR123A, Varta CR123A)

CAUTION: Risk of fire, explosion, and burns. Do not recharge, disassemble, heat above 212°F (100°C) or incinerate. Dispose of used batteries promptly. Keep away from children.

Operating Temperature: 40° to 140°F (6° to 60°C)

Rate-of-Rise Temperature: 15°F (8°C) increase per minute  
NOTE: Rate of rise sensor does not operate above 38°C)

Fixed Temperature: 135°F (57°C)

Maximum Spacing: 50ft x 50ft UL

30ft x 30ft FM

(refer to National Fire Alarm Code Standard NFPA 72 for application requirements)

Dimensions: 4.4" diameter/ 2/2" deep

### TO THE INSTALLER

The rate-of-rise mechanism may be subject to reduce sensitivity over time. Annual testing of the rate-of-rise operation is recommended.

Regular maintenance and inspection (at least annually) by the installer and frequent testing by the user are vital to continuous satisfactory operation of any alarm system.

The installer should assume the responsibility of developing and offering a regular maintenance program to the user as well as acquainting the user with the proper operation and limitations of the alarm system and its components parts. Recommendations must be included for specific program of frequent testing (at least weekly) to ensure the system's proper operation at all times.

### FCC NOTICE

FCC ID: CFS8DL5809EN-1

This device complies with Part 15 of FCC rules. Operation is subject to the following two conditions: (1) This device may not cause harmful interference, and (2) this device must accept any interference received, including interference that may cause undesired operation.

CANADA: 573F-5809EN1

REFER TO THE INSTALLATION AND SETUP GUIDE FOR THE CONTROL PANEL WITH WHICH THIS DEVICE IS USED FOR WARRANTY INFORMATION AND LIMITATIONS OF THE ENTIRE ALARM SYSTEM.



**Honeywell**

165 Eileen Way, Syosset, New York 11791  
Copyright © 2004 Honeywell International Inc.

www.honeywell.com/security



K9948 4/04 Rev. A