

Honeywell

ADEMCO 5811
One Zone Door/Window Transmitter

Installation Instructions

Model 5811 is a single zone Door/Window Transmitter, compatible with alarm systems that support 5800 series wireless devices. 5811 has a unique serial number permanently assigned during manufacture, which must be entered into the control panel upon installation. Refer to the panel's installation instructions for programming details.

NOTE: During programming of the control unit, 5811 transmitters should be treated as "RF" (i.e. supervised RF) Type.

MOUNTING

Choose a mounting location for 5811 where the device is stationary and the magnet is mounted to the moving part of the door or window. To verify adequate signal strength conduct Go/No Go tests (see control's instructions) on 5811 before mounting permanently.

1. **Install Battery** by inserting one edge under one of the two plastic battery retainer clips, then pressing down firmly to snap it beneath both clips; see diagram.

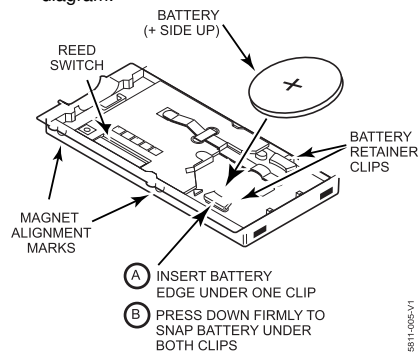

2. **Mount 5811 using double-faced tape** (supplied) by affixing it to the back of the unit and mounting the unit in place. Use screws (optional) if desired; see diagram. Mount the magnet (supplied) near the alignment marks on the case (see Diagram).

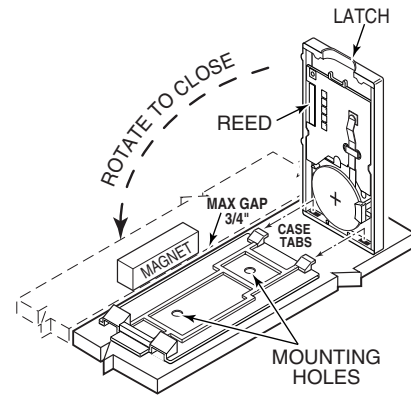

3. Engage the case tabs (see diagram), then rotate the housing to close. Engage latch with firm pressure to close and lock.

BATTERY REMOVAL

1. Open housing by inserting a flat blade screwdriver into latch and twisting gently.
2. Remove old battery cell using a small flat screwdriver blade, as shown in the diagram.

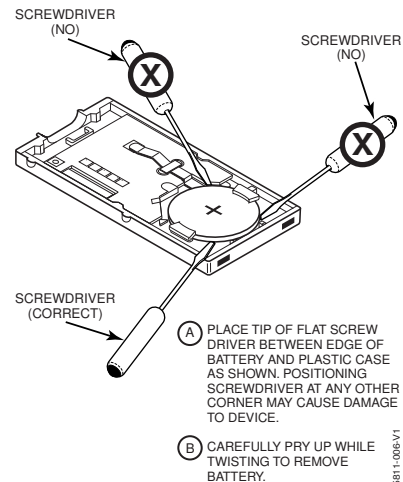

FEDERAL COMMUNICATIONS

COMMISSION STATEMENT: The user shall not make any changes or modifications to the equipment unless authorized by the Installation Instructions or User Manual. Unauthorized changes or modifications could void the user's authority to operate the equipment.

FCC / IC STATEMENT: This device complies with Part 15 of the FCC Rules, and RSS 210 of Industry Canada (IC). Operation is subject to the following two conditions: (1) This device may not cause harmful interference (2) This device must accept any interference received, including interference that may cause undesired operation.

Cet appareil est conforme à la partie 15 des règles de la FCC & de RSS 210 des Industries Canada. Son fonctionnement est soumis aux conditions suivantes: (1) Cet appareil ne doit pas causer d'interférences nuisibles. (2) Cet appareil doit accepter toute interférence reçue y compris les interférences causant une réception indésirable.

SPECIFICATIONS**Dimensions**

2-1/8" (55mm) x 1-3/16" (30mm) x 1/4" (7mm)

Operating Conditions

23° F (-5° C) to 120° F (50° C).
Relative Humidity 95%, (non-condensing)

Replacement Battery

CR2032 Renata/Panasonic/Sener.

WARRANTY INFORMATION

For the latest warranty information, please visit:

www.honeywell.com/security/hsc/resources/wa

REFER TO THE INSTALLATION INSTRUCTIONS FOR THE RECEIVER/CONTROL WITH WHICH THIS DEVICE IS USED FOR DETAILS REGARDING LIMITATIONS OF THE ENTIRE ALARM SYSTEM.

Honeywell

**2 Corporate Center Drive, Suite 100
P.O. Box 9040, Melville, NY 11747
Copyright © 2011 Honeywell International Inc.**



800-03928V1 8/11 Rev. C