

Holdup Switch/Transmitter

INSTALLATION AND SETUP GUIDE

GENERAL INFORMATION

The 5869 Holdup Switch/Transmitter is a finger-operated RF transmitting device used for activating a holdup signal at the security system control, and/or any other security application. The 5869 is typically mounted under a counter or money draw for inconspicuous operation. When the transmitter is activated, it sends an RF signal to the control panel, which then sends a burglary alarm to the central station.

Once the 5869 trigger (Figure 1) is activated, the supplied reset key K4563 must be used to reset the device. The 5869 also contain tamper switches that are activated either when the cover is removed, or when the unit is forcibly removed from its installation location.

The 5869 has a permanent serial number assigned during manufacture used for enrolling the 5869 with the security system control panel. To enroll the 5869, refer to the respective Security System Control Panel Installation and Setup Guide.

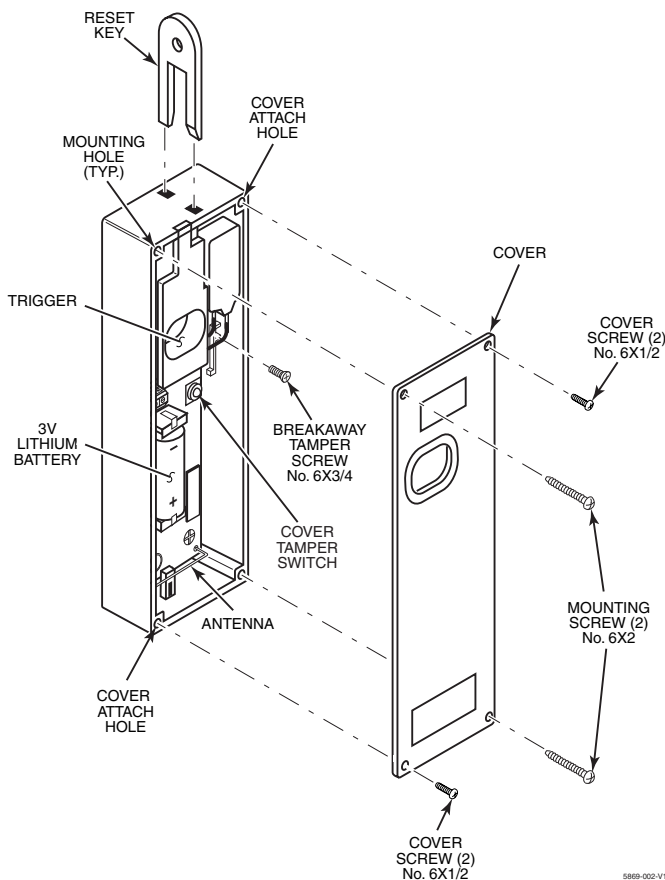

Figure 1. 5869 Holdup Switch/Transmitter Details

MOUNTING

Mount the 5869 under a counter or money drawer for easy access by the cashier. Refer to the figure and steps that follow for typical mounting installation.

Before mounting the 5869 permanently, perform Go/No Go tests to verify adequate transmitter signal strength at desired mounting location (refer to the Security System Control Panel Installation and Setup Guide).

1. Install the battery into the battery holder observing correct polarity as shown in Figure 1.
2. Position the case to the desired location and install one No. 6 x 3/4 screw (supplied) at the breakaway tamper release hole as shown in Figure 2 .
3. Secure the cover to the case with the two screws (No 6 x 1/2) as shown in Figure 2.

IMPORTANT: To prevent damage to the case, do not over tighten the cover screws.

4. Secure the case with the cover to its mounting location using the two screws (No. 6 x 2) supplied as shown in Figure 2.

PROGRAMMING

The 5869 Holdup Switch/Transmitter should be programmed as a 24-hour silent zone type. Refer to the Security System Control Panel Installation and Setup Guide for programming instructions.

NOTES:

- During programming of the control panel, the 5869 Holdup Switch/Transmitter should be treated as "RF" (i.e., supervised RF) Type.
- The 5869 is one closed input loop zone (loop 1).

BATTERY INSTALLATION/REPLACEMENT

BATTERY CAUTION:
Risk of fire, explosion, and burns. Do not recharge, disassemble, heat above 100°C, or incinerate. Dispose of used batteries promptly and properly. Keep away from children.

IMPORTANT: The case will be held in place by the tamper release tab once the cover and mounting screws are removed. Exercise caution not to jar the case while replacing the battery, possibly breaking the Tamper breakaway tab.

1. Remove the screws securing the 5869 cover and case to its mounting location.

NOTE: Use care not to bend the antenna while attempting to remove or install the battery.

2. Remove faulty battery and dispose of properly.
3. Observing correct polarity, insert the battery into the battery holder as shown in Figure 2.
4. Re-install screws to secure cover and case as shown in Figure 2.

SPECIFICATIONS

Physical	1-15/16"W x 5-15/16"H x 1-3/16"D (50mm x 150mm x 30mm)
Battery	3-volt Lithium. ADEMCO 466, Duracell DL123A, Panasonic CR123A, Sanyo CR123A, Varta CR123A, or equivalent.
Frequency	345MHz
Reset Key:	Supplied, Part Number K4563 to order separately
Agency:	UL 636 – Holdup alarm units and systems

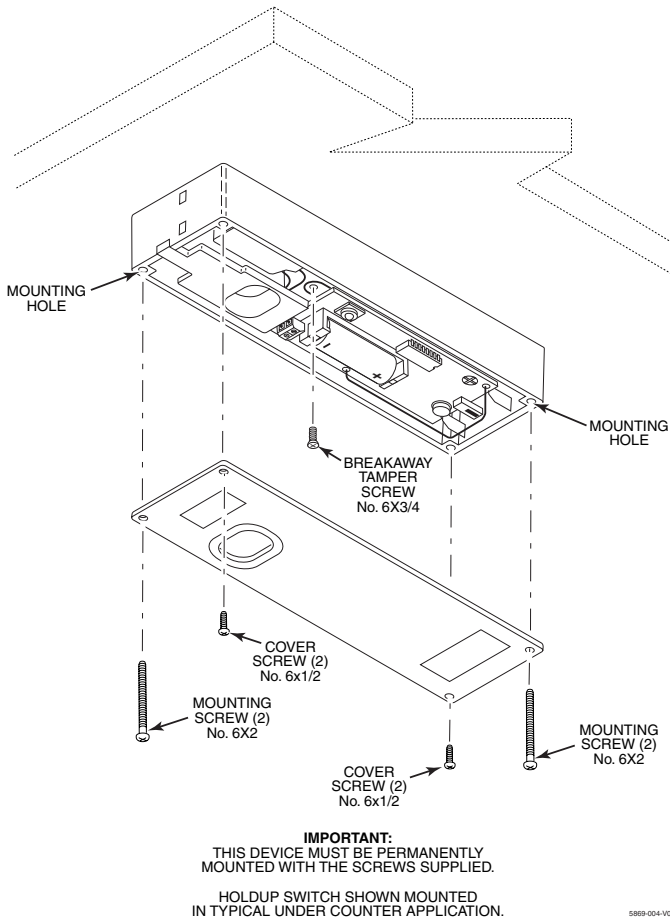

Figure 2. Typical Holdup Switch Installation



TO THE INSTALLER

Regular maintenance and inspection (at least annually) by the installer and frequent testing by the user are vital to continuous satisfactory operation of any alarm system.

The installer should assume the responsibility of developing and offering a regular maintenance program to the user, as well as acquainting the user with the proper operation and limitations of the alarm system and its component parts. Recommendations must be included for a specific program of frequent testing (at least weekly) to insure the system's operation at all times.

FCC ID: CFS8DL5869-1

This device complies with Part 15 of the FCC Rules. Operation is subject to the following two conditions: (1) This device may not cause harmful interference, and (2) this device must accept any interference received, including interference that may cause undesired operation.

CANADA: 573F-58691

LIMITED WARRANTY

Honeywell International Inc., acting through its Security & Custom Electronics business ("Seller") 165 Eileen Way, Syosset, New York 11791, warrants its product(s) to be in conformance with its own plans and specifications and to be free from defects in materials and workmanship under normal use and service for 24 months from the date stamp control on the product(s) or, for product(s) not having a manufacturer's date stamp, for 12 months from date of original purchase unless the installation instructions or catalog sets forth a shorter period, in which case the shorter period shall apply. Seller's obligation shall be limited to repairing or replacing, at its option, free of charge for materials or labor, any product(s) which is proved not in compliance with Seller's specifications or proves defective in materials or workmanship under normal use and service. Seller shall have no obligation under this Limited Warranty or otherwise if the product(s) is altered or improperly repaired or serviced by anyone other than Honeywell factory service. For warranty service, return product(s) transportation prepaid, to Honeywell Factory Service, 165 Eileen Way, Syosset, New York 11791.

THERE ARE NO WARRANTIES, EXPRESS OR IMPLIED, OF MERCHANTABILITY, OR FITNESS FOR A PARTICULAR PURPOSE OR OTHERWISE, WHICH EXTEND BEYOND THE DESCRIPTION ON THE FACE HEREOF. IN NO CASE SHALL SELLER BE LIABLE TO ANYONE FOR ANY CONSEQUENTIAL OR INCIDENTAL DAMAGES FOR BREACH OF THIS OR ANY OTHER WARRANTY, EXPRESS OR IMPLIED, OR UPON ANY OTHER BASIS OF LIABILITY WHATSOEVER, EVEN IF THE LOSS OR DAMAGE IS CAUSED BY THE SELLER'S OWN NEGLIGENCE OR FAULT.

Seller does not represent that the product(s) it sells may not be compromised or circumvented; that the product(s) will prevent any personal injury or property loss by burglary, robbery, fire or otherwise; or that the product(s) will in all cases provide adequate warning or protection. Customer understands that a properly installed and maintained alarm system may only reduce the risk of a burglary, robbery, fire, or other events occurring without providing an alarm, but it is not insurance or a guarantee that such will not occur or that there will be no personal injury or property loss as a result. CONSEQUENTLY, SELLER SHALL HAVE NO LIABILITY FOR ANY PERSONAL INJURY, PROPERTY DAMAGE OR OTHER LOSS BASED ON A CLAIM THAT THE PRODUCT(S) FAILED TO GIVE WARNING. HOWEVER, IF SELLER IS HELD LIABLE, WHETHER DIRECTLY OR INDIRECTLY, FOR ANY LOSS OR DAMAGE ARISING UNDER THIS LIMITED WARRANTY OR OTHERWISE, REGARDLESS OF CAUSE OR ORIGIN, SELLER'S MAXIMUM LIABILITY SHALL NOT IN ANY CASE EXCEED THE PURCHASE PRICE OF THE PRODUCT(S), WHICH SHALL BE THE COMPLETE AND EXCLUSIVE REMEDY AGAINST SELLER.

This warranty replaces any previous warranties and is the only warranty made by Seller on this product(s). No increase or alteration, written or verbal, of the obligations of this Limited Warranty is authorized.

Honeywell

165 Eileen Way, Syosset, New York 11791

Copyright © 2004 Honeywell International, Inc.

www.honeywell.com/security

