

The RF6GB is a wireless glassbreak detector intended for use with Honeywell controls that support SiX™ Series devices.

Mounting

The RF6GB can be mounted on the wall or on the ceiling.

- within 7.6 m (25 feet) of the protected glass;
- within clear view of the protected glass;
- at least 2 m (6.5 feet) from the floor;
- at least 1 m (3.3 feet) from forced air ducts;
- at least 1 m (3.3 feet) from sirens or bells greater than 5 cm (2 inches) in diameter.
- between the protected glass and any heavy window coverings.
- when heavy window coverings are present, the detector can be mounted on the window frame.
- Avoid mounting the detector on the same wall as the protected glass, on free-standing posts or pillars, or in rooms with noisy equipment (air compressors, bells, power tools, etc.), if this equipment is operated when the detector is armed.
- UL requirements: [TBD](#)

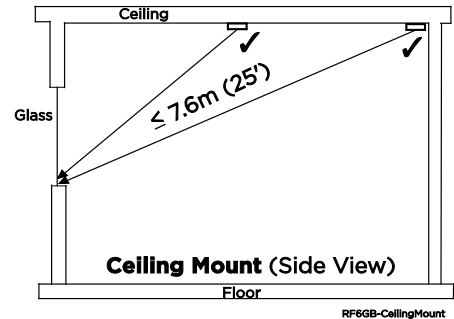
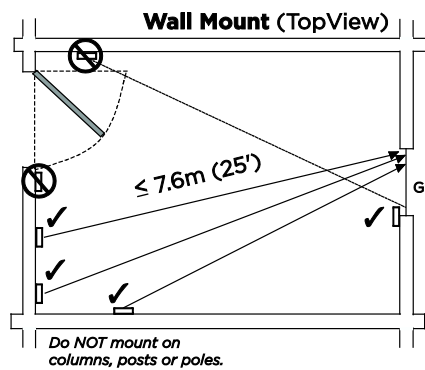
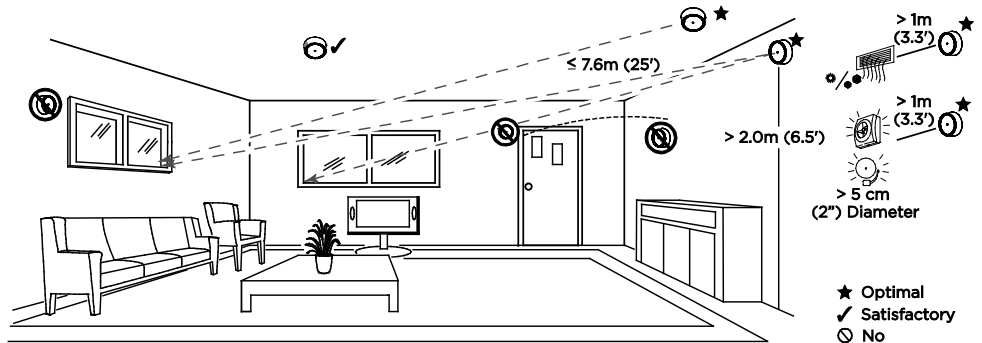

To remove the mounting bracket:

Turn the top of the detector 15 degrees counter-clockwise and separate the mounting bracket.

Note: Before mounting the RF6GB permanently, conduct Go/No Go tests (see control's instructions) to verify adequate signal strength and adjust the device location and orientation as necessary.

- The RF6GB can be mounted on the wall or on the ceiling.
- The rear tamper plate **MUST** be mounted to a stud, solid wood, or with a robust wall anchor.

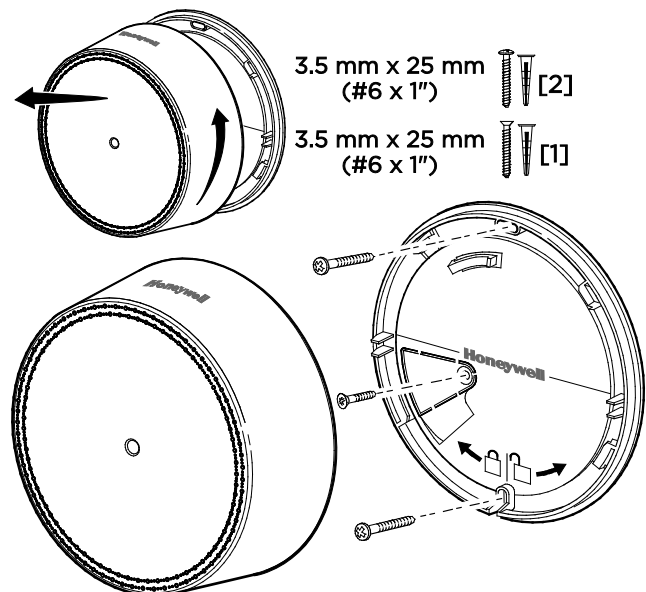

Enroll

This device can be enrolled and programmed either before or after installation.

1. Set the Lyric Smart Controller in Programming Mode.
2. Remove the battery tab to activate the device and begin the enrollment process.
3. The RF6GB Green LED flashes during enrollment (about 8 seconds*)
***Note:** Depending on the signal strength between the device and the control, the enrollment period may take longer than 8 seconds.
 - The device sends its unique MAC ID address (Serial Number) and Services information to the control.
 - The control registers the device and displays the transmitter data on screen.
4. Enrollment is confirmed When the RF6GB Green LED is ON for 3 seconds [and the control beeps TBD].
5. If the sensor is not successfully enrolled during the enrollment period, the LED turns off and the device powers down. Activate the tamper, power down and up again, or use the FG701 Glassbreak Simulator to restart the enrollment process.

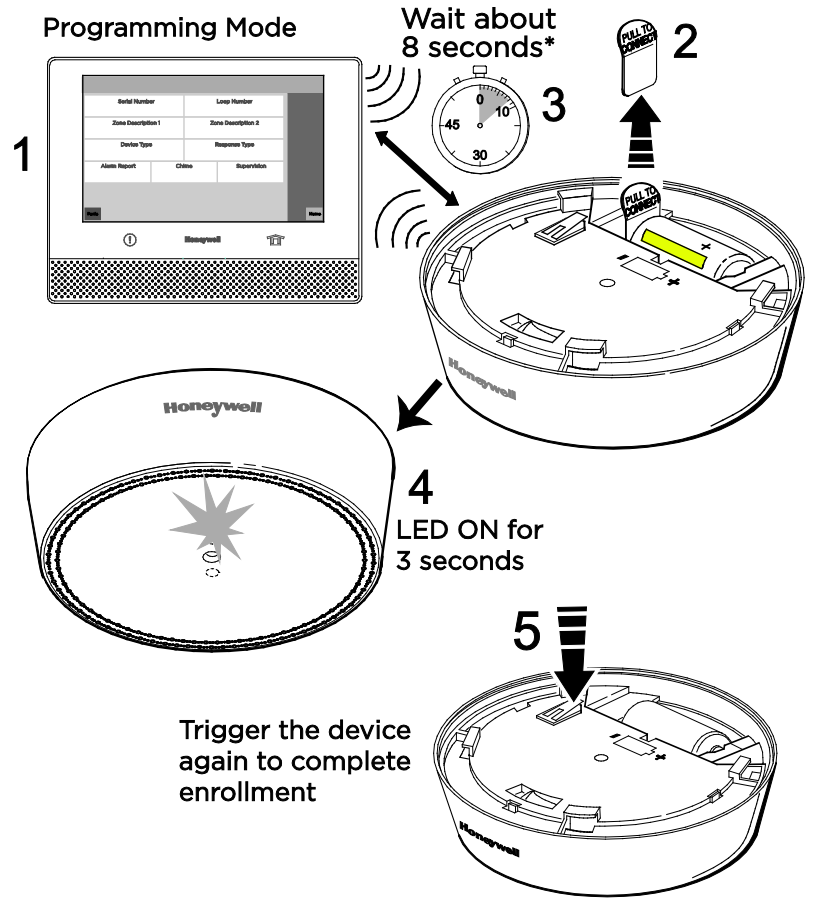

Note: Once enrolled in a system, the detector cannot be used with another control panel until it is removed from the current control panel. See the Control's instructions for details on removing devices.

Program the RF6GB

Consult the Control's instructions for programming the device in the system.

Fault device features to "Learn" device "Services" in the control:

- Tamper switch
- Selectable Sensitivity Settings
- Temperature sensing

Temperature Sensing

Temperature sensing range is 0 - 50°C / 32 - 122°F and is always enabled. Program the system to use the temperature information at the panel.

Sensitivity Setting	Approximate Range
High	4.6-7.6m / 15-25 ft.
Medium	3-4.6m / 10-15 ft.
Low	1.5-3m / 5-10 ft.
Lowest	0-1.5m / 0-5 ft.

The RF6GB detector is Factory set at HIGH sensitivity. Change the sensitivity setting at the Control Panel.

RF6GB LEDs

The RF6GB has three LEDs which are visible when the unit is mounted.

Green 1 LED indicates device enrollment and tamper status.

The Red and Green 2 LEDs provide information on detector status during Test Mode. The Green 2 LED indicates events and the Red LED indicates Alarms.

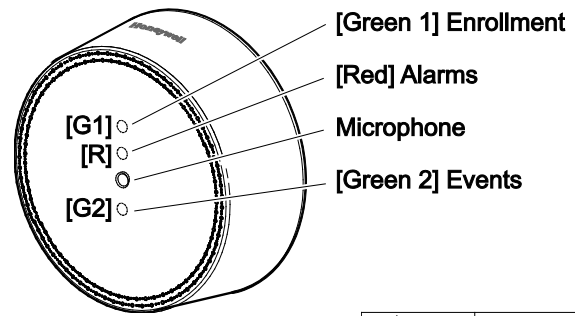

ON	Rapid Flash
OFF	Slow Flash

LED Indications Table

G1	Red	G2	Status
		¹	Test Mode ²
			Event detected during Test Mode
			Alarm detected during Test Mode
	³	³	Low Battery detected during Test Mode
			Power Up / Tamper switch pressed / FG-701 Activated before enrollment
			Tamper Detected

¹ If RF6GB Test Mode is activated by the FG701, the Green 2 LED will flicker, then be off for 3 seconds, then flash once per second.

² Test Mode lasts for 10 minutes.

³ This feature is used for field diagnosis. The LEDs are not visible during Normal Mode to save power.

Test the RF6GB

The RF6GB should be tested after installation and at least once a year.

Test Mode can be activated remotely from the Control Panel (see Control Panel manual), or on-site with an FG-701 Glassbreak Simulator, only when the system is *disarmed*.

Follow directions in the FG-701 Glassbreak Simulator Operating Instructions to activate and test the RF6GB detector.

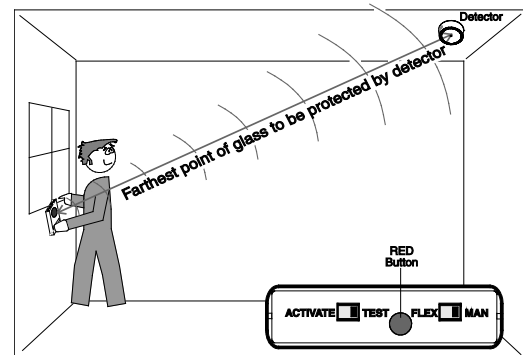

Battery Replacement

- Twist the front cover counterclockwise 15 degrees and separate from the mounting bracket.
- Remove and replace the battery.
Recommended replacement batteries:
Panasonic CR123A Honeywell 466
Duracell DL123 Duracell DL123A
- Reattach the front cover and twist it 15 degrees clockwise to lock it in place.

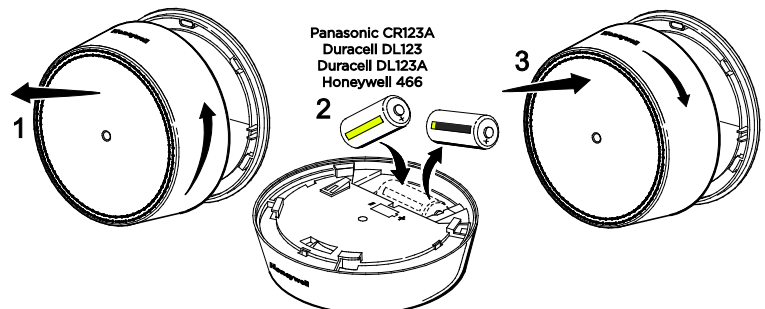

BATTERY CAUTION: Risk of fire, explosion and burns. Do not recharge, disassemble, heat above 100° C (212° F) or incinerate. Dispose of used batteries promptly. Keep away from children.

Specifications

Battery: Panasonic CR123A, Duracell DL 123, Duracell DL 123A, Honeywell 466

Tamper: Cover and Wall

RF Frequency: 2.4GHz

Operating Temperature: 0° to 50° C / 32° to 122° F

Relative Humidity: 5 – 95%, non-condensing

Dimensions: 96 mm Diameter x 29mm Thick / 3.78" Diameter x 1.14" Thick

Approval Listings

RoHS

FCC / IC

ULC S306-03

UL 639



Protected Glass Types Chart [PRELIMINARY – TBD AFTER AGENCY TESTING]

NOTE: The RF6GB is NOT recommended for protection of glass areas smaller than 27.6 cm x 27.6 cm (10-7/8 inches x 10-7/8 inches).

Glass Type*	Nominal Thickness	
	Minimum	Maximum
Plate	2mm (3/32 in.)	10mm (3/8 in.)
Tempered	3mm (1/8 in.)	10mm (3/8 in.)
Laminated ^{1,3}	3mm (1/8 in.)	14mm (9/16 in.)
Wired	6mm (1/4 in.)	6mm (1/4 in.)
Coated ^{2,3}	3mm (1/8 in.)	6mm (1/4 in.)
Sealed Insulating ^{1,3}	3mm (1/8 in.) [13mm (1/2 in.) overall]	6mm (1/4 in.) [19mm (3/4 in.) overall]

* Minimum size for all types is 28cm (11 in.) square; glass must be framed in the wall or mounted in a barrier at least 0.9m (36 in.) wide.

¹ Protected only if both plates in the unit are broken

² Coated glass with security films up to 0.35mm (14 mils) thick (including films for solar protection) may be used. Evaluated with the these products: 3M SCOTCHSHIELD SH14CLARL - 0.35mm (14 mils), 4 ply film; Film Technologies International, Inc.'s GLASS-GARD GGLL 1200 has been evaluated with this product by Underwriters Laboratories, Inc.

³ In compliance with Underwriters Laboratories of Canada's Standard for Intrusion Detection Units (CAN/ULC-S306-M89):

a. Plate glass 3mm (1/8-in.) to 10mm (3/8-in.) can be used.

b. ULC recognizes a maximum range for protecting sealed insulating glass, 1/8" laminated and coated glass of 3.8m (12.5 ft.); sensitivity should be set to High.

FEDERAL COMMUNICATIONS COMMISSION & INDUSTRY CANADA STATEMENTS

The user shall not make any changes or modifications to the equipment unless authorized by the Installation Instructions or User's Manual. Unauthorized changes or modifications could void the user's authority to operate the equipment.

FCC / IC STATEMENT

This device complies with Part 15 of the FCC Rules, and RSS-210 of Industry Canada. Operation is subject to the following two conditions: (1) This device may not cause harmful interference, and (2) This device must accept any interference received, including interference that may cause undesired operation.

Cet appareil est conforme à la partie 15 des règles de la FCC & de RSS-210 des Industries Canada. Son fonctionnement est soumis aux conditions suivantes: (1) Cet appareil ne doit pas causer d'interférences nuisibles. (2) Cet appareil doit accepter toute interférence reçue y compris les interférences causant une réception indésirable.

RF Exposure

Warning – The antenna(s) used for this device must be installed to provide a separation distance of at least 7.8 inches (20 cm) from all persons and must not be co-located or operating in conjunction with any other antenna or transmitter except in accordance with FCC multi-transmitter product procedures.

Mise en Garde

Exposition aux Fréquences Radio: L'antenne (s) utilisée pour cet émetteur doit être installée à une distance de séparation d'au moins 7,8 pouces (20 cm) de toutes les personnes.

Support and Warranty

REFER TO THE INSTALLATION INSTRUCTIONS FOR THE CONTROL WITH WHICH THIS DEVICE IS USED, FOR DETAILS REGARDING LIMITATIONS OF THE ENTIRE ALARM SYSTEM.

For the latest U.S. warranty information, please go to www.honeywell.com/security/hsc/resources/wa or Please contact your local authorized Honeywell representative for product warranty information.