

Specifications:

Input Voltage:	100 – 277 VAC
Input Frequency:	60 Hz
Relays:	Normally open, SPST, zero crossing control
Max Switched Current:	5A Ballast/5A Tungsten (LC-2R = 5A x 2 relays)
Radio Frequency:	2.4 GHz
RF Transmission Output Power (Average):	+12 dBm
Dimensions:	7" 5/8 L x 1" 3/16 W x 1" H
Voltage measurement:	2% accuracy full scale
Current measurement:	2% accuracy full scale
Operating Environment:	40 to 140 deg F
Memory:	Configuration programming stored in non-volatile memory
Wires:	24" Long, 600 VAC Rated, 18 AWG solid conductors
Mounting:	Magnets or screws inside of a UL-rated fixture or enclosure rated for the application.

Ordering Information:

Catalog Number	Description
LC - 1R	Single relay
LC - 2R	Two relay
LC - 1RD	Single relay with 0-10 VDC dimming
XA	Optional external antenna

Class A digital devices

This equipment has been tested and found to comply with the limits for a Class A digital device, pursuant to Part 15 of the FCC Rules. These limits are designed to provide reasonable protection against harmful interference when the equipment is operated in a commercial environment. The equipment generates, uses and can radiate radio frequency energy and, if not installed and used in accordance with the instruction manual, may cause harmful interference to radio communications. Operation of the equipment in a residential area is likely to cause harmful interference in which case the user will be required to correct the interference at his/her own expense.

WARRANTY INFORMATION

Adura Technologies™ warrants its products to be free of defects for a period of five years. Adura Technologies will, at its option, repair or replace any product that is defective in materials or manufacture that is returned to ADURA within the warranty period. This warranty is void if this product has been installed improperly or in an improper environment, overloaded, misused, or altered in any manner, or not installed in accordance with any labels or instructions. Adura Technologies is not liable for incidental, indirect, special, or consequential damages, including without limitation, damage to, or loss of use of property, revenue or profit. This warranty does not cover the cost of installation, removal or reinstallation.

INSTALLATION INSTRUCTION MANUAL

The Light Controller is to be used to control lighting in commercial and industrial buildings. It provides control of lights (on/off or dimming) by means of commands transmitted and received via radio frequency. The Light Controller is intended to be used in a network of devices which communicate wirelessly including wall switches, occupancy sensors, gateways and computer software applications.

The Light Controller is to be mounted inside the enclosure of a light fixture or in a separate UL- rated enclosure. In the case of fluorescent lights, the Light Controller is to be installed inside the ballast cavity of a standard fluorescent luminaire.

The Light Controller is intended to be used to control fluorescent ballasts, incandescent lights, LED drivers, and HID ballasts.

There are 3 models of the Light Controller:

- **LC-1R** has one relay and is intended to control one light fixture or group of light fixtures.
- **LC-2R** has two relays and is intended to control two levels of light within one fixture or two fixtures or two groups of light fixtures.
- **LC-1RD** has one relay and a low voltage dimming output (Class 1 rated) intended to control standard 0-10 VDC dimming ballasts. Each LC-1RD can provide dimming control to a maximum of 5 standard 0-10 VDC dimming ballasts.

Installation Materials (Not Supplied)

Wiring connectors. All existing wiring connectors must be replaced with new UL-listed wiring connectors, either wire nuts or captive-type connectors. All wiring connectors must be correctly sized for the application, the number and the size of the electrical conductors.

Sheet metal screws. As an option, the Light Controller can be secured with 2 #8 sheet metal screws.

CAUTION

- Disconnect all incoming power before installation or service.
- All installation and maintenance work must be performed by qualified personnel.
- The Light Controllers must be installed in accordance with state, local and national electrical codes and requirements.
- Light Controller must be installed within a UL-rated fixture or enclosure rated for this application.

To install the Light Controller take the following steps:

1. Turn off all power to the light fixtures by switching off the circuit breaker or other disconnect.
2. Open the fixture cover and remove the cover for the ballast cavity. The ballast and its wiring should now be visible. (See Figure #1)
3. With a volt meter, verify that power is off to the light fixture.
4. Place Light Controller in the desired location and secure with the magnets on the rear of the Light Controller or screw it down.
5. Disconnect the hot wire to the ballast (black for 120 VAC or brown for 277 VAC).
6. Connect the black wire on the Light Controller wires to the hot wire (black for 120 V or brown for 277 V) using a wiring connector (see wiring diagram #1 for one relay and wiring diagram #2 for two relays).

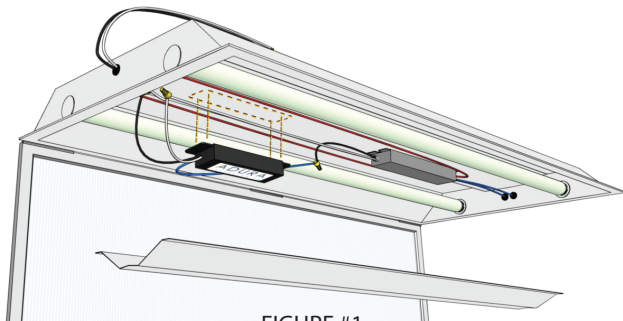

FIGURE #1

7. Connect the blue wire on the Light Controller to the black wire on the ballast using a wiring connector.
8. Connect the white wire on the Light Controller to the white wire on the ballast and to the white wire on the incoming power wiring using a wiring connector.
9. Bend wires into place such that ballast cover can easily be reattached.
10. Reattach the ballast cover and close the luminaire cover.

11. Switch power on to the fixture. Lights should turn on.
12. Refer to the setup application instructions for information on programming the light controller.

Dimming Control (LC-1RD)

(See wiring diagram #3)

CAUTION: LOW VOLTAGE WIRING MUST BE TREATED AS CLASS 1

1. Connect the gray wire on the LC-1RD to the gray wire or gray terminal on the dimming ballast.
2. Connect the violet wire on the LC-1RD to the violet wire or violet terminal on the dimming ballast.
3. When switched on, lamps should turn on to full brightness. (Approximately 10 VDC signal on the Violet wire to ground).

Dimensions:

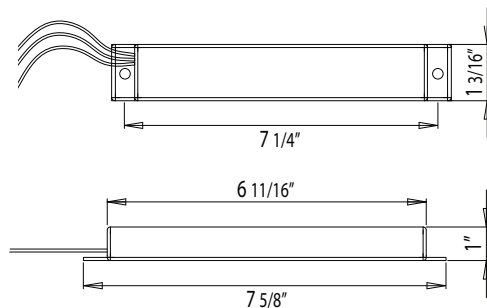

Wiring Diagram #1 LC-1R

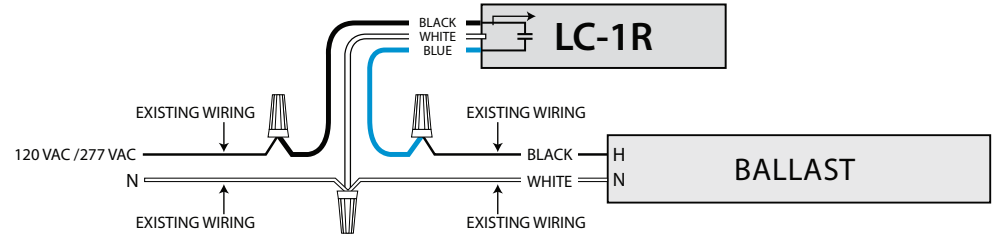

Wiring Diagram #2 LC-2R

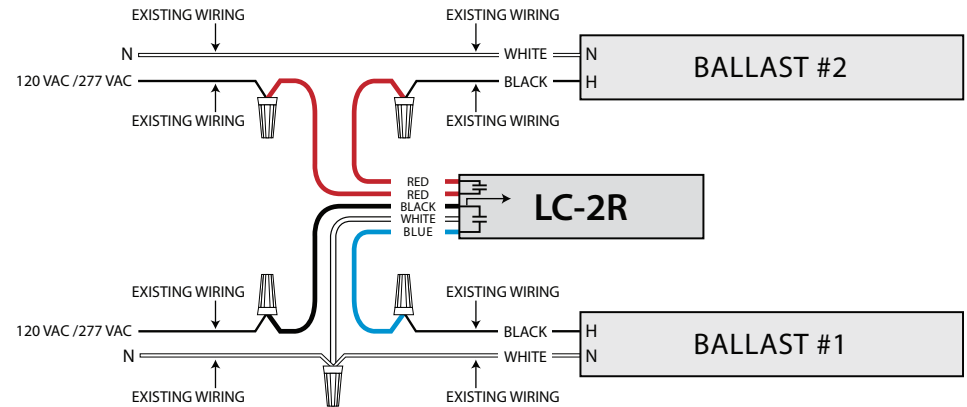

Wiring Diagram #3 LC-1RD

