



OWNER'S MANUAL

Model: PLUS-4800

For Technical Assistance, please call (800) 638-3600,
or visit www.magnadyne.com

Congratulations on your purchase of a quality Carbine automotive security system. Carbine automotive security products have been designed to provide the consumer with a product that is technologically superior and will provide years of trouble free operation.

The information enclosed will provide a ready reference of the operation and maintenance of your new security system.

Remote Control Transmitters

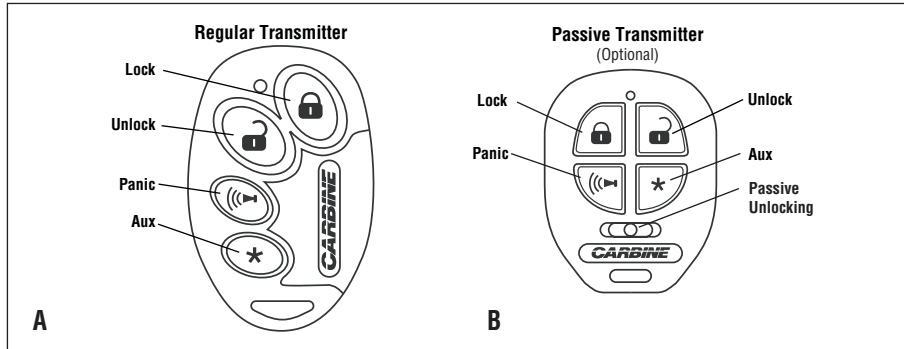

Security System Operation: (using the transmitter to arm the security system)

- Exit the vehicle and close all entrances.
- Press and release the LOCK button. The security system will respond as follows:
 - The horn/siren will chirp one time.
 - The LED indicator will begin to flash at a steady rate.
 - The parking lights will flash one time.
 - The starter disable device will become armed and the vehicle engine will not crank.
 - All protected entrances are armed.

Note: If the dome light is on or a sensor is active at the time you arm your security system, you will hear the horn/siren beep one time and then you will hear another beep from the horn/siren about 5 seconds later. The second beep is the active sensor warning indicator. This second beep tells you that the alarm is armed but one of the sensors has been temporarily deleted because it was "On" at the time the alarm was armed.

The security system is now fully armed!

Automatic Arming (without using the transmitter)

Note: The following information is valid only if your security system has been programmed to automatically arm.

- Turn off the ignition key and exit the vehicle.
- Close all protected entrances. After the last protected entrance is closed the horn/siren will chirp one time and the LED indicator will begin to flash fast. The fast flashing LED indicates that the automatic arming timer is counting down and the security system will become armed within 30 seconds. After 30 seconds has passed, the security system will respond in the following manner:

Automatic Arming (without using the transmitter) (Continued)

- A. The horn/siren will chirp one time.
- B. The LED indicator will begin to flash slower.
- C. The parking lights will flash one time.
- D. All protected entrances are armed.

Note 1: Re-opening a protected entrance before the system becomes armed will stop the arming timer. After closing the entrance the timer will begin counting again from zero.

Note 2: If the vehicle has a delayed interior lighting system, the automatic arming timer will start counting after the interior lighting has turned itself Off. This could add up to 45 seconds to the total automatic arming countdown time (up to 75 seconds total arming delay).

The security system is now fully armed!

Disarming the Security System Using the Regular Transmitter (A)

Press and release the UNLOCK button. The security system will respond as follows:

- A. The horn/siren will chirp two times.
 - B1. The LED indicator will be Off (only if Auto Arming is programmed Off).
 - B2. The LED indicator will be flashing very fast (only if Auto Arming is programmed On).
- C. The parking lights will flash two times.

Note: If you are disarming the security system after it has been triggered and the horn/siren is sounding, the disarm chirps are automatically deleted.

Disarming the Security System Using the Passive Transmitter (B)

Note: When using the passive transmitter the on/off switch must be in the "On" position.

- A. Walk toward your vehicle and the security system will respond the same as pushing the UNLOCK button.

The security system is now disarmed!

Override Switch Operation

Your Carbine security system is supplied with a override switch system. This switch is used to override the security system in the event that the transmitters are lost or fail to operate, and to put the security system in non-operational mode.

Override Switch Operation (Continued)**Override Operation:** (Security System is Armed)

1. Enter the vehicle (the security system will begin sounding at this point).
2. Place the ignition key into the ignition switch and turn the switch to the "On" position.
3. Within 5 seconds of turning the ignition key "On", place the override switch to the "On" position.
4. The horn/siren will stop sounding.
5. The LED indicator will be solid red.

The security system is overridden.

Note 1: If the override switch is already in the "On" position when you turn "On" the ignition key, the override function will be bypassed. Turn "Off" the ignition key, place the override switch in the "Off" position and try again.

Note 2: If you fail to place the override switch to the "On" position within 5 seconds of turning "On" the ignition key, the override function will be locked-out. Place the switch in the "Off" position, turn "Off" the ignition key and try again.

Remote Valet Mode Operation:**Activate Valet Mode**

1. Turn the ignition key to the "Off" position and open any door.
2. Press and hold down the LOCK + ★ buttons.
3. The door locks will lock and unlock. Release the buttons.
4. The LED will begin to flash every 5 seconds indicating that the system is in Valet Mode.

Exit Valet Mode

1. Turn the ignition key to the "Off" position and open any door.
2. Press and hold down the UNLOCK + ★ buttons.
3. The door locks will lock and unlock. Release the buttons.
4. The LED will be off indicating that the system is out of the Valet Mode.

Remote Panic:

Press and hold the LOCK or PANIC button for more than 3 seconds and the security system will respond in the following manner:

- A. The horn/siren will begin sounding.
- B. The parking lights will begin flashing.

To turn off the panic alarm, press and release the UNLOCK or PANIC button. The horn/siren will stop sounding and the parking lights will stop flashing.

Note: If you do not turn off the panic feature with the transmitter, the panic alarm will sound for 60 seconds and then turn off by itself.

User Discretion Silent Arming:

Your security system can be instructed to become armed or disarmed without the horn/siren chirps by the transmitter. To operate this feature at any time, simply press the LOCK and UNLOCK buttons at the same time to arm or disarm your security system without the chirp indications.

60 Second Rearming:

If your Carbine security system has become triggered, the horn/siren will sound for 60 seconds and then stop and reset to a fully armed condition.

Note: If a protected entrance is left open, your security system will remain triggered for two more 60 second cycles then fully rearmed excluding the door input trigger (door input trigger is no longer functional). Closing the entrance will reset the door input trigger within 7 seconds.

Secondary RF Protection Mode:

Every time you disarm your security system with your transmitter, the security system will start an RF protection mode countdown. This is a timed secondary protection mode to ensure that after the system is disarmed by radio signal, it will count down for 60 seconds and then become rearmed if no one enters the vehicle.

Note: This feature is only active when the security system has been programmed to automatically arm.

Remote Shock Sensor Delete:

As conditions require, you may want to delete the shock sensor function. To do this, press the LOCK button to arm the system. Then press it a second time to delete the sensor function. You will then hear a second chirp from the horn/siren.

Note: This is a one-time action. The next time the vehicle is armed the shock sensor function will be active.

Alarm Mode Indicators:

1. The LED indicator will provide information on 7 modes of security system operation:
 - LED is off = Security system is disarmed.
 - LED is flashing = Security system is armed.
 - LED is flashing fast = Automatic arming timer or RF protection mode timer is counting down.
 - LED is on solid = Security system is in valet mode (only when the ignition key is on).
 - LED is flashing once every 5 seconds = Security system is in valet mode (Only when ignition key is off).
 - LED is flashing in a 2 flash-pause sequence = Tamper warning – security system has been triggered from the hood/trunk switch or electronic sensor.
 - LED is flashing in a 3 flash-pause sequence = Tamper warning – security system has been triggered from an opened door.
2. The horn/siren will provide information on the 4 modes of security system operation.
 - One horn/siren chirp = Security system is armed.
 - One horn/siren chirp + One more chirp 5 seconds after the first chirp = Security system is armed but one of the sensors was on and the alarm has bypassed it. The remaining sensors are armed.
 - Two horn/siren chirps = Security system is disarmed.
 - Four horn/siren chirps = Tamper warning + security system is disarmed.

Upgrade Options:**Option #1:** Remote Power Door Lock/Unlock Control

Note: Your vehicle must have an electronic door locking system for this feature to operate.

Installing Option #1 will allow the transmitter to lock and unlock your vehicle's doors as it arms and disarms your security system.

Option #2: Remote Trunk/Hatch Release (Channel #2)

Installing Option #2 will allow the transmitter to open your vehicles trunk or rear hatch. Pressing the ★ button for 2 seconds will open the existing power trunk/hatch release mechanism.

Note: Vehicles that are not factory equipped with an electronic trunk release system will require additional parts.

Option #3: Dome Light Illumination

Installing Option #3 will allow your security system to turn on your vehicles interior illumination system at the time the security system is disarmed by the transmitter. The interior lighting will remain on for 30 seconds after the security system is disarmed. Turning on the ignition key will turn off the interior illumination before 30 seconds.

Option #4: Single-Zone Shock Sensor

Installing Option #4 will increase the level of security provided by your security system. If the shock sensor becomes activated, the security system will immediately trigger your security system by sounding the horn/siren and flashing the parking lights.

Option #5: Starter Disable Relay

Adding Option #5 will increase the level of protection that your security system can offer. When the starter disable module is installed, the vehicles engine will not crank when the alarm system is in the armed mode.

Option #6: Unlock Drivers Door First (Requires Option #1 to be installed)

Installing Option #6 will allow your security system to unlock only the drivers door upon disarming the security system. To unlock the remaining doors, press the UNLOCK button once again within 3 seconds of disarming the security system. The remaining doors will become unlocked.

Option #7: Dual-Zone Shock Sensor

Installing Option #7 will increase the level of security provided by your security system. Zone #1 of the dual-zone shock sensor will detect lighter non-threatening disturbances that would normally set off most sensors and trigger the security system. If Zone #1 is activated the security system will emit a single chirp from the horn/siren. This single chirp is a pre-warning if a would-be thief is attempting to enter your vehicle. Zone #2 detects heavier impacts that are considered threatening and immediately triggers your security system by sounding the horn/siren and flashing the parking lights.

Programmable Features:

The following is a brief description of the operation of each programmable feature. Any adjustment to the operation of these features must be performed by the dealer who installed your Carbine Security System. These features are not user adjustable.

Ignition Key Controlled Door Lock/Unlock: (Remote door lock/unlock option must be installed)

With this feature activated, the door lock system of the vehicle will become locked 3 seconds after the ignition key is turned to the on position (all doors). When the ignition key is turned to the off position, the door locks will immediately become unlocked (all doors).

Note: This feature has 3 modes in which it can operate. Mode #1 operates as explained above and is the most common operation. Mode #2 locks the doors when the ignition key is turned on but does not unlock the doors when the ignition key is turned off. In Mode #3 the ignition key locking feature is off.

Chirp Status Indicator Delete: (Permanent Chirp Delete)

De-activating the chirp indication system will eliminate the arm and disarm chirp indicators. For your safety, the tamper warning chirp indicator will always be active.

Automatic Arming of Security System:

When the automatic arming of security system feature is programmed on, the security system will automatically become armed 30 seconds after the last protected entrance is closed without requiring a signal from the transmitter (Ignition switch must be off).

Automatic Door Locking: (Remote door lock/unlock option must be installed)

If it is desired to have the vehicle's power door locking system become locked at the same time the security system becomes armed by the automatic arming of security system feature, the automatic door locking programming should be on.

Safety Illumination Sentinel System (SISS):

Programming on the Safety Illumination Sentinel System will provide the vehicle user with a lighted pathway to and from the vehicle when the security system is armed and disarmed.

With the SISS programmed on, the parking lights and the dome light will remain on for 12 seconds after the security system is armed providing a lighted pathway while leaving the vehicle.

In addition, the parking lights and dome light will remain on for 30 seconds after the security system is disarmed immediately drawing attention to your vehicle while providing a fully lighted vehicle interior and exterior.

This device complies with part 15 of the FCC rules. Operation is subject to the following two conditions.

- 1) This device may not cause harmful interference, and**
- 2) This device must accept any interference received, including interference that may cause undesired operation.**

Per FCC 15.21, you are cautioned that changes or modifications not expressly approved by the part responsible for compliance could void the user's authority to operate the equipment.

System Maintenance:

The only maintenance that your Carbine security system requires is a periodic check that its functions are operating properly. The battery supplied with regular transmitter (A) will last about 1 year and the battery supplied with passive transmitter (B) will last about 6 months. Heavier usage will shorten battery life. Reduced transmitter range is usually a sign that the transmitter battery is becoming weak and should be replaced.

Battery Replacement:

Replacement batteries for your transmitter are available at most drug stores and camera shops. To replace the battery, remove the small phillips screw from the transmitter case and pull apart the top and bottom case halves. Remove the battery from its holder. Insert the new battery in place of the old one observing the batteries +/- polarity. Gently snap the top and bottom case halves together. Replace the phillips screw, but DO NOT over tighten.

Replacement Transmitters:

In the event that the transmitters supplied with your security system become damaged or lost, return to the facility that installed your security system to purchase a new one.

Limited Lifetime Warranty

Magnadyne Corporation or its authorized agents will, for the life of the vehicle and to the original purchaser, repair, replace or refund the retail sales price of said product or any part thereof, at the option of the Magnadyne Corporation or its authorized agents, if said product or part is found defective in materials or workmanship, when properly connected and operating on the correct power requirements designated for the specific product. This warranty and Magnadyne Corporation or its authorized agents obligations, hereunder do not apply where the product was: damaged while in the possession of the consumer, subjected to unreasonable or unintended use, not reasonably maintained, utilized in commercial or industrial operation, or serviced by anyone other than Magnadyne Corporation or its authorized agent, or where the warning seal on the product is broken or the power plugs or wires are detached from the unit. Magnadyne Corporation or any of its authorized agents do not assume any labor costs for the removal and reinstallation of any product found to be defective, or the cost of transportation to Magnadyne Corporation or its authorized agents. Such costs are the sole responsibility of the purchaser.

This warranty does not cover the cabinet, appearance items, normal wear and tear or accessories used in connection with the product resulting from improper installation, alteration, accident, misuse, abuse or acts of nature.

This Limited Life Time Warranty applies only to the receiver section of the security system. Neither the siren, transmitters, wire harness or any accessory item added to or used with a Remote Mobile security system are covered by this Limited Life Time Warranty. Sirens, transmitters, wire harness or any accessory item are covered by our standard 12 month limited warranty.

Magnadyne Corporation or its authorized agents shall not be liable to anyone for consequential or incidental damages or claims that may arise due to failure of product to operate properly except those accorded by law. Magnadyne's or its authorized agents liability to the repair, replacement of the product as stated above if all conditions of the warranty are met. No expressed warranty or implied warranty is given except those set forth herein. Magnadyne does not warrant or guarantee against break in damage or the theft of the vehicle in part or whole, or against the loss or damage to the contents of any vehicle in which a security system is installed. Magnadyne security systems are only a deterrent against possible theft.

This warranty extends only to the original purchaser of the product and for the vehicle in which it was originally installed. This warranty is not transferable or assignable to any person or vehicle. Defective merchandise should be returned to the original point of purchase or secondly to Magnadyne Corporation, 1111 W. Victoria Street, Compton, CA 90220. A return authorization must be obtained before sending, or merchandise may be refused.



INSTALLATION MANUAL

Model: PLUS-4800

This device complies with part 15 of the FCC rules. Operation is subject to the following two conditions:

- (1) This device may not cause harmful interference; and
- (2) This device must accept any interference received, including interference that may cause undesired operation.

Note: The manufacturer is not responsible for any radio or TV interference caused by unauthorized modifications to this equipment. Such modifications could void the user's authority to operate the equipment.

**For Technical Assistance, please call (800) 638-3600,
or visit www.magnadyne.com**

Table of Contents

Step 1: Component Installation	2-3
Step 2: 10-Pin Main Harness Installation	3-4
Step 3: 5-Pin Power Harness Installation	4-5
Step 4: Optional Accessory Connections	6-11
Step 5: Transmitter Programming	12-13
Step 6: Remote Feature Programming	14
Step 7: General Testing	15
Step 8: Speciality Feature and Optional Equipment Testing	15-18
Specifications	18
Wiring Diagram	19

Warning! Do not plug the 10-pin or 5-pin wire harness into the alarm control module before you begin installing the alarm. The wire harnesses must be plugged into the alarm control module after all connections are made. Failure to follow this procedure could cause some confusion with transmitter operation and or alarm function operation.

Step 1: Component Installation

Mounting the Control Module:

Find a suitable location to secure the alarm control module within the passengers compartment of the vehicle. Never mount the alarm control module in the engine compartment or in the trunk. In addition, never mount the alarm control module in the direct path of the heater. Secure the alarm control module by using wire ties or drill two 1/8" holes and secure the module to the frame of the vehicle with the screws provided.

Mounting the Siren:

Find a suitable location in the engine compartment to secure the siren. Select a location that provides a direct sound path to the ground for maximum siren output. Use the self tapping screws provided and secure the siren. Connect the black wire coming from the siren to the frame of the vehicle. In many cases, you can ground the black wire to one of the screws used to secure the siren. Run the remaining brown wire through the fire wall to the location of the alarm control module.

Installing Hood/Trunk Pin Switches:

Provided with the alarm kit is one pin switch and one mounting bracket. To install the switch either in the truck or under the hood, find a suitable location where the switch will make contact with the hood or trunk lid and will not get wet. Use the bracket provided or drill a 1/4" hole in the desired location.

Step 1: Component Installation (Continued)

Installing the Alarm Status LED:

Find a suitable location for the LED and drill a 5/16" hole in the desired location. Feed the 2-pin plug through the hole and press the body of the LED into place. Run the LED wires to the location of the alarm control module.

Step 2: 10-Pin Main Harness Installation

The main wire harness contains 8 wires which all have a specific purpose. Follow the wiring recommendations enclosed for each wire. Wires not used should be released from the harness connector or taped off to prevent accidental shorting. Included with the 10-pin wire harness are two loose wires, an orange wire and a white wire with black stripe. See main harness and power harness wiring instructions for these two loose wires.

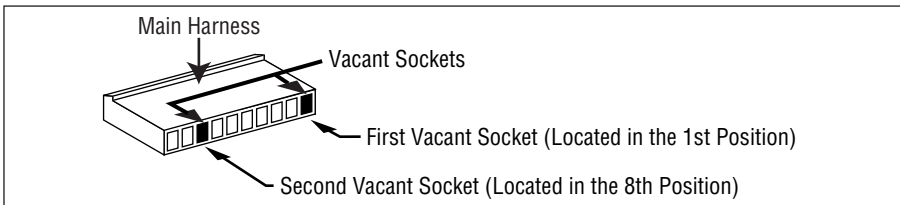

First Vacant Socket: (For Use with ALA-RPT Relay Pack Only)

See Optional Accessory Connection for proper wiring.

Gray Wire: (Pulsed Ground for Car Horn)

The gray wire is a pulsed ground output designed to activate the vehicle's existing car horn system in place of or in addition to a siren sounding device. Connect the gray wire to the negative trigger wire on the vehicle's horn relay.

WARNING! Maximum output of this wire is 300mA. Horn systems requiring positive voltage or more than 300mA to trigger the horn relay will require an additional relay to increase current capabilities.

Step 2: 10-Pin Main Harness Installation (Continued)

Brown Wire: (Siren + Output)

Connect the brown wire to the positive wire from the siren. Ground the remaining wire from the siren for proper operation.

Blue Wire: (Optional Grounding Sensor Input)

The blue wire is an instant grounding trigger input for optional hood/trunk grounded pin switches or any electronic sensor.

Green Wire: (Grounded Door Pin Switch Input)

The green wire connects to the common wire of the vehicle that switches on the dome light. Normally this wire is located at one of the door jamb switches. For some vehicles it may be necessary to connect the green wire directly to the switched turn on wire at the dome light. The green wire connects to negative switched circuits only.

Violet Wire: (Positive Door Pin Switch Input)

The violet wire connects to the common wire of the vehicle that switches on the dome light. Normally this wire is located at one of the door jamb switches. For some vehicles it may be necessary to connect the violet wire directly to the switched turn on wire at the dome light. The violet wire connects to positive switched circuits only.

Second Vacant Socket:

The second vacant wire socket provides a 1 second pulsed ground (300mA) output when Channel #2 is activated (See Optional Accessory Connections).

Red / White: (Pulsed Parking Light Relay Output)

Connect the red/white wire to the parking light wire coming from the headlight switch. Do not connect the red/white wire to the dashboard lighting dimmer switch – Damage to the dimmer will result. Use a volt meter to test the connection point before connecting the red/white wire. While checking, rotate the dimmer switch to make sure you do not have the dimmer lead. The limitation of the red/white wire is 10 Amp max. Do not exceed this limit or damage to the alarm and parking light relay will result.

Pink: (Parking Light Relay Input)

The pink wire is the input to the flashing parking light relay. The connection of the pink wire will determine the output polarity of the flashing parking light relay. Connect the pink wire to (+) battery to have (+) output from the relay or connect the pink wire to frame ground to have ground output from the relay.

Step 3: 5-Pin Power Harness Installation

The power harness contains 3 wires and two vacant sockets. Follow the wiring recommendations enclosed for each wire.

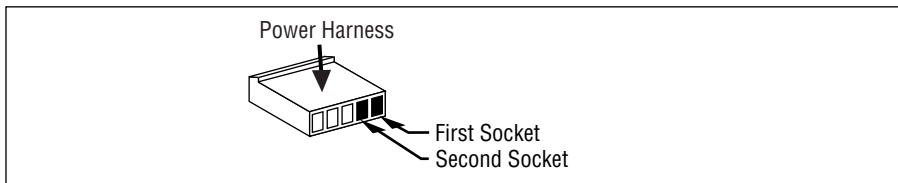

First Vacant Socket:

The first vacant wire socket is a low current (300mA) grounded output wire that can be used to activate the vehicle's interior lighting system when the security system is disarmed. An additional relay is required for proper installation (See Optional Accessory Connection for proper wiring).

Second Vacant Socket:

See Optional Accessory Connection for proper wiring.

Red Wire: (Main Power Input)

Connect the red wire directly to the (+) battery post for best operation of the alarm system. For best current sensing capability from the alarm's current sensing circuit, connect the red wire to the constant power wire coming from the interior dome light.

Black Wire: (Main Ground Input)

Connect the black wire directly to the frame of the vehicle. Use a bolt and nut to secure the wire. Scrape away any grease or paint that might prevent a good connection.

Yellow Wire: (Switched +12 Volts From the Ignition Switch)

Connect the yellow wire to a +12 volt wire that is switched on and off by the ignition key. The correct wire will indicate +12 volts when the ignition key is in the on and start positions. Do not connect the yellow wire to the "ACC" wire coming from the ignition switch.

Step 4: Optional Accessory Connections

Power Door Lock / Unlock Activation

3 Wire Positive Trigger Door Lock System

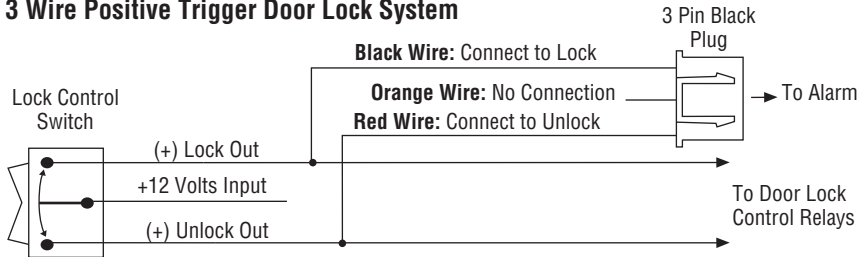

Note: Prewired Door Lock Interconnect T-Harness are Available for Most Vehicles

3 Wire Ground Trigger Door Lock System

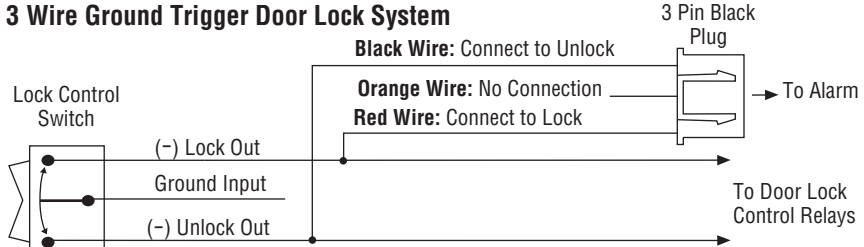

Note: Prewired Door Lock Interconnect T-Harness are Available for Most Vehicles

5 Wire Ground at Rest Door Locking Systems

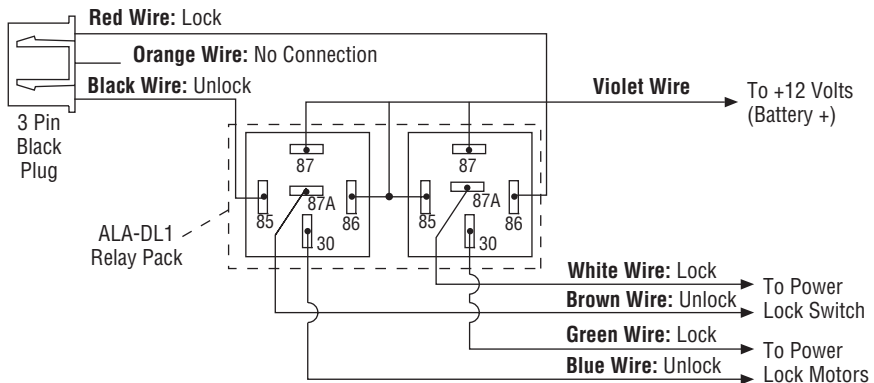

Note: Prewired Door Lock Interconnect T-Harness are Available for Most Vehicles

Step 4: Optional Accessory Connections (Continued)

Mercedes Door Lock Activation

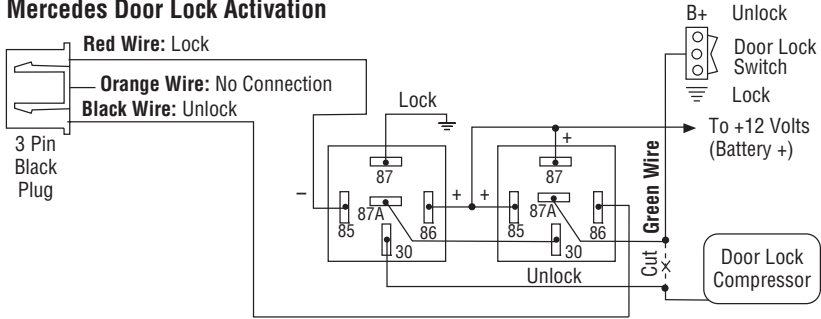

Newly Installed Power Door Lock Motors

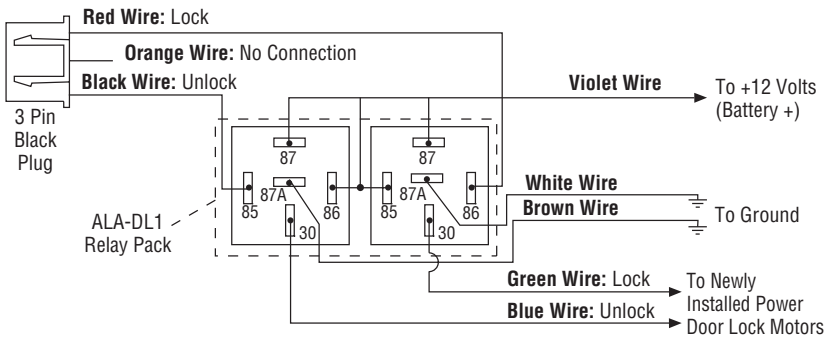

One Wire Multiplexing Door Locking Systems

Some vehicle's (Chrysler, Mazda and Ford Probe and others) use one wire to lock and unlock the doors. Example: When the door lock controller sees a signal thru a resistor it will unlock. If a signal is received without a resistor the doors will lock. Some use 2 resistors. One for lock and one for unlock. We have developed patented plug-in fuse resistors for this application. Simply remove the fuse from our door lock module and replace with correct resistor value fuses that matches the vehicles door lock switch.

ALA-DL1 Wiring:

1. Connect both the green (lock) and the blue (unlock) wires to the vehicles one wire lock/unlock wire.
2. Connect our violet polarity input wire to +12v or to ground. To match vehicles door lock polarity
3. The white and the brown wires will not be used.

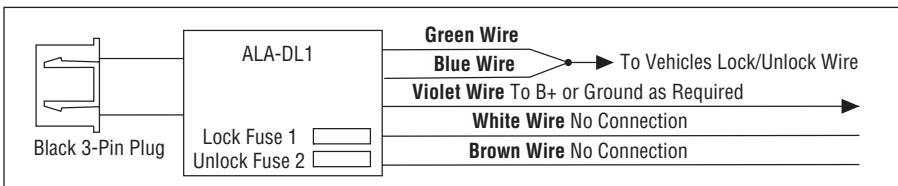

Step 4: Optional Accessory Connections (Continued)

Unlock Driver® Door First for 3-Wire Negative Door Lock Systems

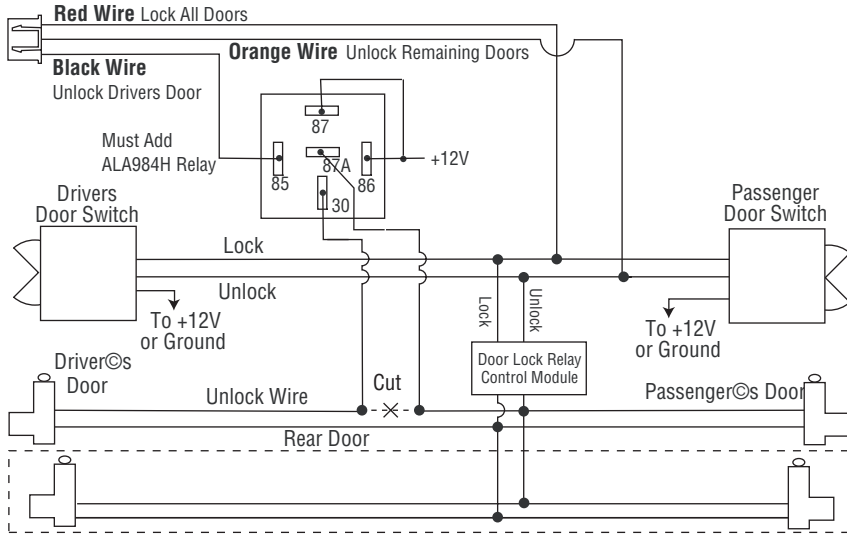

Unlock Driver® Door First Wiring for 3-Wire Positive Door Lock System

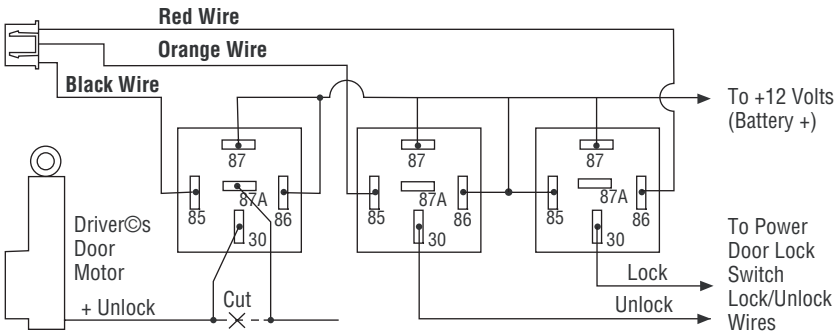

Step 4: Optional Accessory Connections (Continued)

Starter Disable Wiring Using a Common Relay

Using the wiring information and diagram below, connect the optional starter disable relay as follows:

- Locate the "Start Only Wire" coming from the ignition key switch and cut it.
- Connect the ends of the cut start wire to pins #30 and 87a of the relay pack.
- Connect the single gray wire harness supplied (with 2-pin black connector) to pin #85 on the relay.
- Connect pin #86 to the true ignition switched wire from the ignition key.

To test the starter disable system refer to the starter disable testing procedures located in the testing section of this manual.

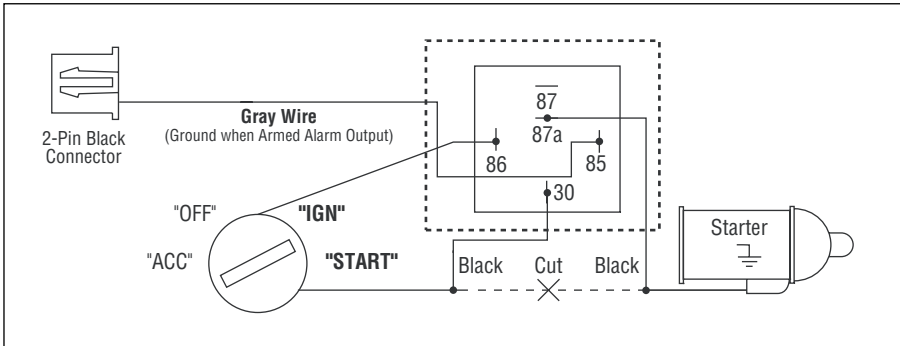

Starter Disable Wiring Using ALA-RPS Relay Pack

Using the wiring information and diagram below, connect the optional starter disable relay as follows:

- Locate the "Start Only Wire" coming from the ignition key switch and cut it.
- Connect the ends of the cut start wire to the black wires coming from the ALA-RPS relay pack.
- Plug in the orange 2-pin plug into the orange socket located at the rear of alarm module.

To test the starter disable system refer to the starter disable testing procedures located in the testing section of this manual.

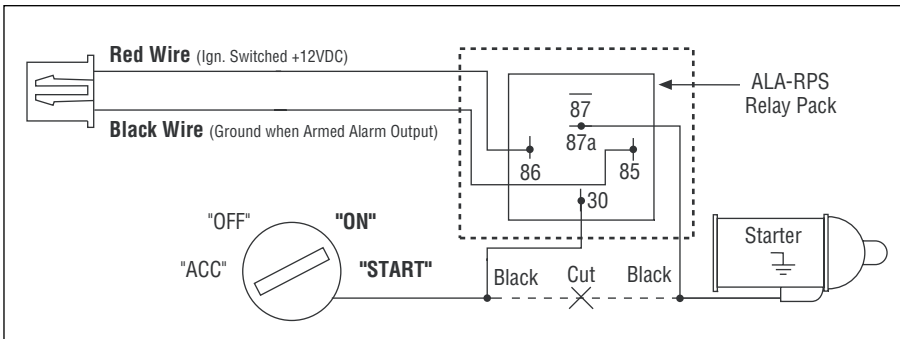

Step 4: Optional Accessory Connections (Continued)

Flashing Parking Lights

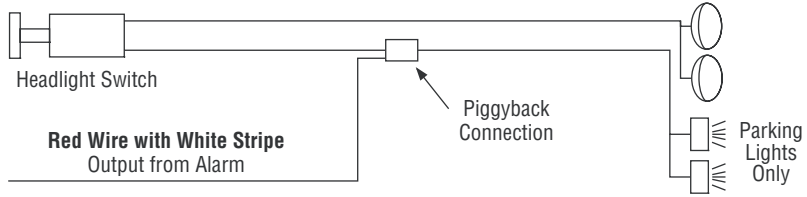

Override Switch with 2-Pin Blue Plug:

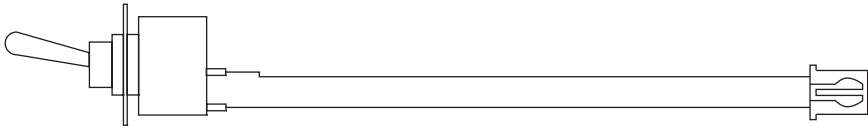

Dual-Zone Electronic Sensor Plug (Optional):

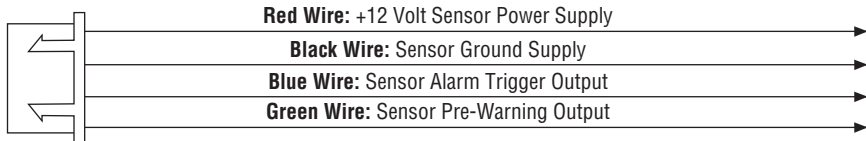

4 Pin White Plug

Alarm Status LED Indicator with White 2-Pin Plug:

Plug the white 2-pin plug into white receptacle located in the side of the control module.



Step 4: Optional Accessory Connections (Continued)

Dome Light Supervision Using Optional ALA-RPT Relay Pack:

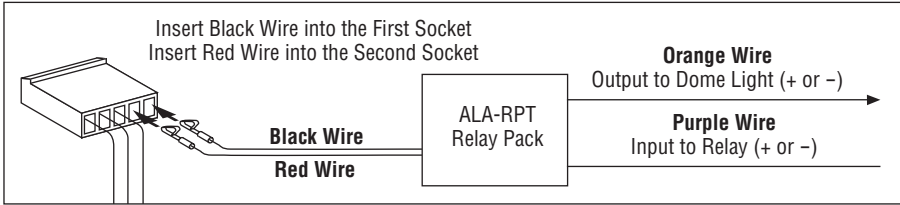

Dome Light Supervision Using Optional 30 Amp Relay:

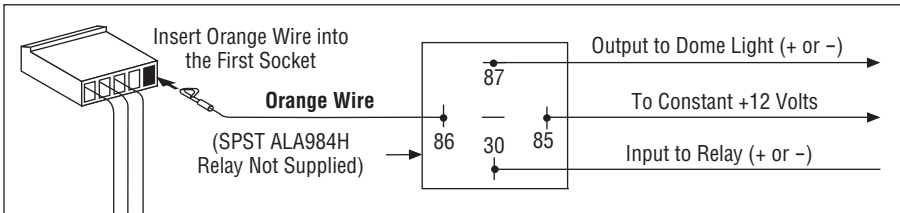

#2 Button Power Trunk Activation Using Optional ALA-RPT Relay Pack

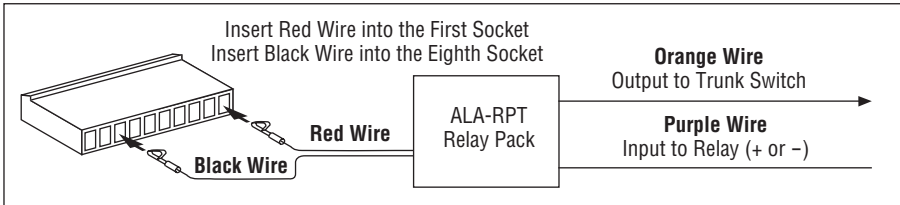

#2 Button Power Trunk Activation Using Optional 30 Amp Relay

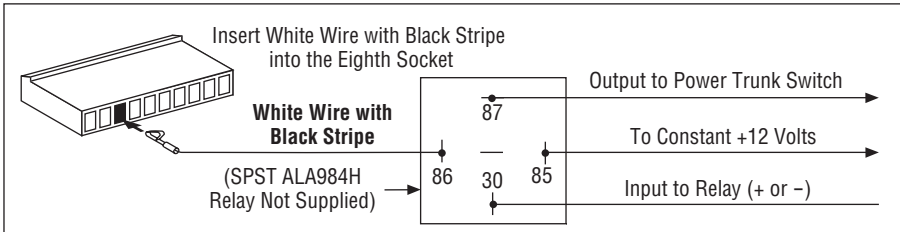

Step 5: Transmitter Programming

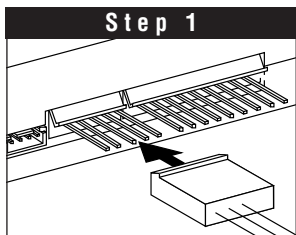

Plug In the Power Harness

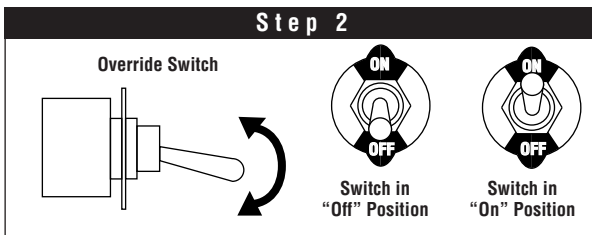

Make Sure the Override Switch is in the Off Position

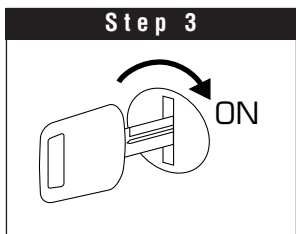

Turn On Ignition

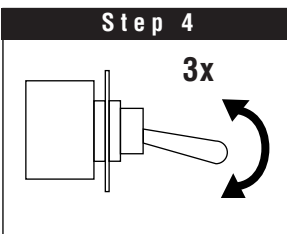

Flip the Override Switch On then Off 3 Times

The siren will chirp 1 time. You are now in the transmitter code programming mode. The LED will be a solid red.

Step 5: Transmitter Programming (Continued)

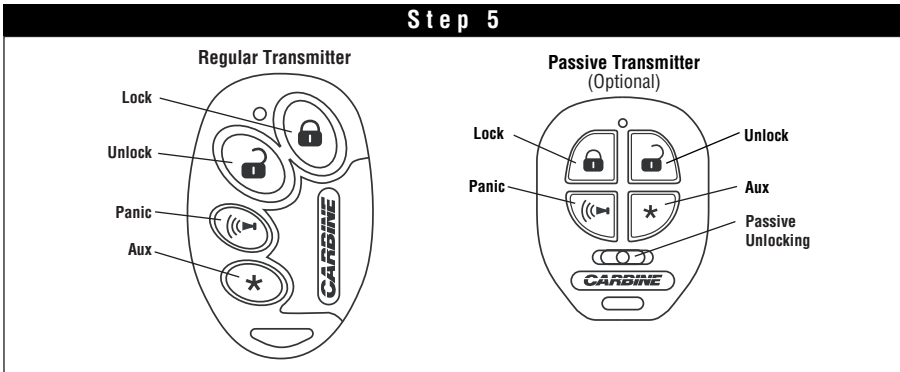

Push Lock Button

The LED will begin flashing slowly and the horn/siren will emit 1 short chirp. The code has now been learned.

The transmitters supplied are pre-programmed to the receiver module. You should use the following instructions when adding a new or replacement transmitter.

Step 6

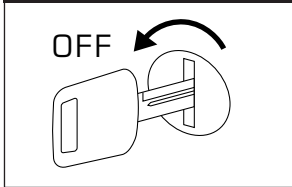

Turn Off the Ignition

The horn/siren will emit 1 short chirp and 1 long chirp. You are now out of the consumer transmitter code learning mode. The LED is Off.

Step 6: Remote Feature Programming

Step 1

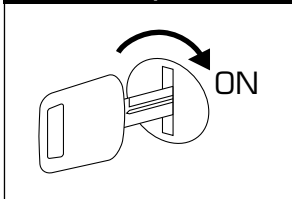

Turn On Ignition



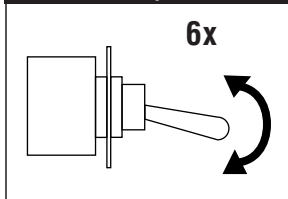





Step 2



Flip the Override Switch On then Off 6 Times

The siren will emit 1 long chirp and 1 short chirp. You are now in the transmitter code programming mode. The LED will be a solid red.

Step 6: Remote Feature Programming (Continued)

#	Transmitter Button	Function	Confirmation = Change Function
1		Chirp Status Indication	1 Beep = Chirp Status Indication "On" with Single Unlock Pulse * 2 Beeps = Chirp Status Indication "Off" with Single Unlock Pulse 3 Beeps = Chirps "On" with Dual Unlock Pulses On 4 Beeps = Chirps "Off" with Dual Unlock Pulses On
2		Last Door Closed Automatic Arming	1 Beep = Automatic Arming "On", Alarm will arm 10 seconds after door is closed and rearm 10 seconds after remote disarm 2 Beeps = Automatic Arming "On", Alarm will arm 20 seconds after door is closed and rearm 20 seconds after remote disarm 3 Beeps = Automatic Arming "On", Alarm will arm 30 seconds after door is closed and rearm 60 seconds after remote disarm 4 Beeps = Automatic Arming "Off" *
3		Ignition Key Controlled Door Locks	1 Beep = Door will Lock 3 seconds after Ignition is Turned "On" Door will not Unlock when Ignition is Turned "Off" 2 Beeps = Door will Lock 3 seconds after Ignition is Turned "On" Door will Unlock when Ignition is Turned "Off" 3 Beeps = Door will not Lock 3 seconds after Ignition is Turned "On" Door will not Unlock when Ignition is Turned "Off" *
4		Power Door Lock Output Timing	1 Beep = .8 second duration output * 2 Beeps = 3.5 second duration output
5		Passive Arm Locking Control	1 Beep = Allows the door lock to lock when the alarm automatically arms. 2 Beeps = Delayed auto arm locking is ON. Doors will become locked 30 seconds after the auto arm timer has run out and armed the security system (shock and current sense is delayed) 3 Beeps = Prevents the door locks from locking when the alarm automatically arms *
6		Current Sensing	1 Beep = Current Sensing "On" 2 Beeps = Current Sensing "Off" *
7		Safety Illumination Sentinel System (SISS)	1 Beep = Safety Illumination Sentinel System "On". Parking lights will remain on for 12 seconds after the alarm is armed by the remote control. The parking lights will also remain on for 30 seconds after the alarm is disarmed by the remote control. Turning on the ignition key will turn Off the lights before the 30 seconds expires. 2 Beeps = Safety Illumination Sentinel System "Off" *
8		Channel 2 Output	1 Beep = Momentary Channel 2 Output * 2 Beeps = Latched Channel 2 Output until the ignition key is turned ON 3 Beeps = Channel 2 will have output as long as the TX button is held 4 Beeps = Channel 2 will have output for 15 seconds 5 Beeps = Channel 2 will have output for 30 seconds
9		Horn Output	1 Beeps = Horn output with chirps and shock sensor warn-away signals * 2 Beeps = Horn output only upon alarm trigger and panic trigger only

* Default Setting

Step 7: General Testing

To test the basic functions of the alarm system repeat the following procedures:

1. Turn off the ignition key and exit the vehicle closing all protected entrances.
 2. Press the LOCK button on the transmitter. You will hear a siren/horn chirp, the parking lights will flash one time and the LED status indicator will flash at normal speed.
 3. Wait 5 seconds, then open a protected entrance. The siren/horn will begin to sound. Press the UNLOCK button once again and the siren/horn will stop sounding (No Disarm Chirp Indicator).
- Note:** If you press the UNLOCK button when the siren/horn is sounding, there are no disarming chirps. When you press the UNLOCK button when the siren is off, there will be disarming chirps.
4. Follow procedures 2 and 3 for all other protected entrances.

Step 8: Speciality Feature and Optional Equipment Testing

Each speciality feature listed operates in the same manner regardless of the alarm model. Test each feature by following the procedures enclosed to ensure proper operation.

Remote Panic:

1. Press and hold the PANIC button down for approximately 3 seconds when using the 4-button transmitter. When using the key transmitter, LOCK button performs as panic.
 2. The alarm will begin to sound and the parking lights will begin to flash.
 3. Press the UNLOCK button and the siren/horn will stop sounding and the lights will stop flashing.
- Note:** The remote panic feature has an automatic shut off circuit. When the siren/horn has sounded for 60 seconds, the panic circuit will turn itself off automatically.

Starter Disable: (Also applies if ALA-RPS2 was installed to interrupt other circuits)

1. Enter the vehicle and close all the entrances.
2. Press the LOCK button on the transmitter.
3. Turn the ignition key to the start position. The engine will not crank over.
4. Turn the ignition key to the Off position and press the UNLOCK button on the transmitter.
5. Turn the ignition key back to the start position and the engine will crank over and start.

Remote Shock Sensor Delete: (Applies when arming is performed with the transmitter)

1. Press the LOCK button to arm the system (you will get 1 chirp from the horn/siren and 1 flash from the parking lights).
2. Within 3 seconds, press the LOCK button a second time. You will hear a second single chirp from the horn/siren and the parking lights will flash a second time. The shock sensor function is now "Off" and will return to normal function at the next occurrence when the alarm is manually armed.

Note 1: If the chirp functions have been programmed "Off", you will only get the light flash indication.

Note 2: The remote shock delete function will operate even if the auto arming feature is active as long as you manually arm the system before the auto timer runs out and arms the system.

Remote Valet Mode Operation:

Activate Valet Mode

1. Turn the ignition key to the "Off" position and open any door.
2. Press and hold down the LOCK + ★ buttons.
3. The door locks will lock and unlock. Release the buttons.
4. The LED will begin to flash every 5 seconds indicating that the system is in Valet Mode.

(continued)

Step 8: Speciality Feature and Optional Equipment Testing (Continued)

Exit Valet Mode

1. Turn the ignition key to the "Off" position and open any door.
2. Press and hold down the UNLOCK + ★ buttons.
3. The door locks will lock and unlock. Release the buttons.
4. The LED will be off indicating that the system is out of Valet Mode.

Override Operation: (Security System is Armed)

1. Enter the vehicle and the security systems will begin sounding at this point.
2. Place the ignition key into the ignition switch and turn the ignition switch to the "On" position.
3. Within 5 seconds of turning the ignition key "On", place the override switch to the "On" position.
4. The horn/siren will stop sounding.
5. The LED indicator will be solid red.

The security system is now overridden.

Note 1: If the override switch is already in the "On" position when you turn "On" the ignition key, the override function will be bypassed. Turn "Off" the ignition key, place the override switch in the "Off" position and try again.

Note 2: If you fail to place the override switch to the "On" position within 5 seconds of turning "On" the ignition key, the override function will be locked out. Place the override switch in the "Off" position, turn "Off" the ignition key and try again.

Last Door Automatic Arming: (If Programmed On)

Note: The automatic arming feature will not operate unless the alarm input triggers have been connected directly to the existing or newly installed door jamb pins. Current sensing alone will not activate the automatic arming circuit.

1. Press the UNLOCK button to disarm the alarm.
2. Set the ignition key to the "On" position, then turn it "Off".
3. Exit the vehicle. The siren/horn will chirp 1 time when the door is closed.
4. The LED will begin to flash fast.
5. After 10, 20 or 30 seconds have passed (depending on remote feature programming), you will hear a single chirp. The alarm is now armed.
6. The LED will flash at a regular rate indicating an armed condition.

Note: When the automatic arming feature is activated, so is the RF tamper rearm circuit. Every time the alarm is disarmed by remote, the RF tamper rearm circuit will count for sixty seconds (LED will be flashing fast) and the alarm will rearm itself if no one has entered the vehicle.

Step 8: Speciality Feature and Optional Equipment Testing (Continued)

LED Status Indicator Operation:

LED is off = Alarm is disarmed.

LED is flashing = Alarm is armed.

LED is flashing in a 2 flash hold sequence = Tamper warning, alarm was triggered by the hood/trunk or electronic sensor.

LED flashing in a 3 flash hold sequence = Tamper warning, alarm was triggered by an open door.

LED is on steady = Alarm is in the valet mode (Ignition key is "On").

LED flashes once every 5 seconds = Alarm is in the valet mode (Ignition key is "Off").

LED is flashing fast = Automatic arming timer is counting down or RF tamper rearming timer is counting down.

Parking Light Flash Alarm Status Indication:

One light flash = Alarm is armed.

Two light flash = Alarm is disarmed.

Three light flash = Tamper indicator, alarm is disarmed.

Siren/Horn Chirp Alarm Status Indication:

Note: This feature can be programmed Off (See Remote Feature Programming for details).

One chirp = Alarm is armed and all input trigger wires are clear.

Two chirps = Alarm is disarmed and has not been tampered with.

Chirps once, pauses then chirps again = Alarm is armed but sensor is bypassed.

Four chirps = Tamper indicator, alarm is disarmed.

Power Door Lock/Unlock: (If Installed)

1. Press the LOCK button on the transmitter, the locks will become locked.

2. Press the UNLOCK button on the transmitter, the locks will become unlocked.

RF Tamper Rearm:

Note: This feature is activated automatically when the alarm is programmed for automatic arming. See "Remote Feature Programming" for details.

1. Alarm must be programmed for automatic arming.

2. Close all protected entrances and press the LOCK button on the remote transmitter. The LED will be flashing at a normal rate.

3. Wait 5 seconds and press the UNLOCK button on the remote transmitter. The LED will begin to flash fast (Automatic arming indicator).

4. Wait 60 seconds and the alarm will become rearmed.

5. Repeat Steps 1 through 4. When the LED starts flashing fast, open one of the protected entrances (door) the LED will be "Off" and remain "Off".

60 Second Rearm Timer and Relock Function:

Once the alarm is triggered, the siren will sound for 60 seconds and then stop. The alarm will remain in an armed condition. If the door locks have been installed into the system, they will relock when the alarm resets after 60 seconds.

Step 8: Speciality Feature and Optional Equipment Testing

Ignition Controlled Door Locking: (Door lock activation must be installed)

When programmed on in "Remote Feature Programming", ignition controlled locking is active 3 seconds after the ignition key is set the On position, the door locks will automatically become locked. When the ignition key is turned to the Off position, the door locks will unlock.

Note: If a protected entrance (door) is opened when the ignition key is set to the On position, the door locks will not lock. This protective measure can not be deleted.

Channel #2 Output: (If Installed)

Press and hold the Channel 2 activation button (★) for 2 seconds. The designated Channel 2 output wire from the alarm will become grounded for as long as the (★) button is pressed.

Dual-Zone Sensor Pre-Warning Indicator: (If Installed)

1. Close all protected entrances and place the alarm in an armed condition.
2. Rap the vehicles body panels to activate the pre-warning zone of any dual-zone type sensor.
3. When the pre-warning indicator is triggered, the horn/siren will beep 1 time.

Specifications

Power Requirements	12.5 Volts Negative Ground
Trigger Inputs	Grounded Pin Switch, Positive Pin Switch, Electronic Sensor Ground, 0.6 Volt Current Drop
Current Requirements	Less Than 15mA Armed or Disarmed
Timers	Programmable Automatic Arming Timer Programmable Rearming Timer 60 Second RF Tamper Rearming Timer 5 Second Zone Bypass Re-Activation Timer
Grounded Output Wire Capacity (White Wire)	500mA
Siren Output Wire Capacity	2 Amps
Channel 2 Pulsed Output	300mA
Bypass Zones	2 Zones
Transmitter Frequency	434mHz
Digital Code Combinations	68,000,000,000
Code Method	Digital Code Hopping
Transmitter Buttons	No More than 4

PLUS-4800 Wiring Diagram

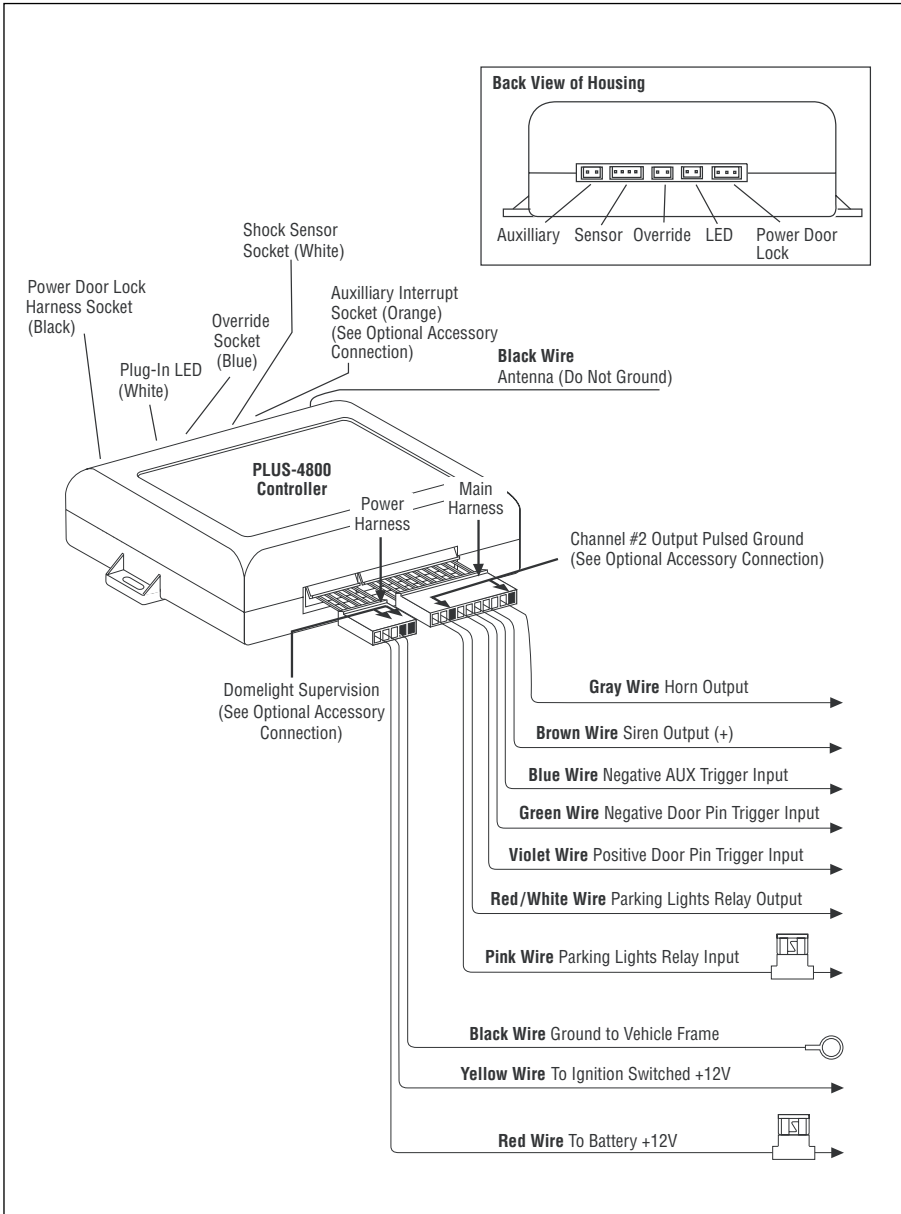

This device complies with part 15 of the FCC rules. Operation is subject to the following two conditions. □

- 1)•This device may not cause harmful interference, and □
- 2)•This device must accept any interference received, including interference that may □ cause undesired operation. □

□

Per FCC 15.21, you are cautioned that changes or modifications not expressly approved □ by the part responsible for compliance could void the user's authority to operate the □ equipment. □

□

□

CARBINE[®]
Plus